

INSTALLATION AND OPERATING INSTRUCTIONS

Y-200 Series

Electronic Boiler Sequencer & Outdoor Reset Control System



Raypak[®]
A Rheem[®] Company



is a registered trademark of Underwriters Laboratories Inc. ®

Rev. 10 reflects the following:

Changes to: Fig. 7 on page 11, Program Mode instructions on page 16, Illustrated Parts List on page 38

Additions: None

Deletions: None

CONTENTS

IMPORTANT SAFETY

INSTRUCTIONS 4

INTRODUCTION 4

Concept of Operation 4

Y-200 Controller Configurations 5

Y-200 Options 5

INSTALLATION 6

Mechanical Installation 6

Electrical Installation 6

Controller Field Wiring 8

Communication Field Wiring 9

Air Temperature Sensor Installation 9

Water Temperature Sensor Installation 10

Power Test 11

Installation Verification Procedure 12

CONTROLLER

FAMILIARIZATION 12

Control Screens 13

Circuit Board Layout 15

Keypad 16

Control Screen Displays &
Programming 17

01 Initial Screen 17

02 Primary Parameters 17

03 Control Band 18

04 Offset 19

05 Holiday 20

06 Reset Ratio 20

07 System Status 22

08 Water Temperature 23

09 Outdoor Cut-Off Temperature 23

10 Outdoor Cut-Off Deadband 23

11 System Monitor 24

12 System Temperatures 24

13 Auxiliary Delay 25

14 Boiler/Stage On Delay 25

15 Boiler/Stage Off Delay 26

16 PID 26

17 System Temperatures 27

18 Lead Change Time 27

19 Password 28

20 Setup 28

21 System Test 29

22 Set Password 29

23 Water Temperature Limits 29

24 Master Unit 30

25 Slave Unit 31

26 LonWorks 31

27 Factory Defaults 31

28 User Defaults 32

29 Modem Password 32

30 Alarm Call Telephone 33

31 Alarm Call ID 33

32 Alarm Call Retry 33

33 Alarm Call Events 33

34 PID 34

Master Unit with Slaves 34

Y-200 Master/Slave Diagram 36

Sensor Resistance 37

Illustrated Parts List 38

WARRANTY 39

Y-200 SERIES ELECTRONIC BOILER CONTROL

SAFETY INSTRUCTIONS

NOTE: These instructions are intended for use by qualified personnel who are specifically trained and experienced in the installation of this type of equipment and related system components. Installation and service personnel may be required by some states to be licensed. If your state requires certification, be sure your contractor bears the appropriate license. Only qualified persons shall attempt to repair this equipment. Repair must be according to these instructions.

WARNING: Improper installation, adjustment, alteration, service or maintenance may damage the equipment, create a hazard resulting in asphyxiation, explosion, fire, electric shock, personal injury or property damage, and will void the warranty.

CAUTION: MORE THAN ONE (1) SUPPLY SOURCE. THIS APPLIANCE HAS PROVISIONS TO BE CONNECTED TO MORE THAN ONE (1) SUPPLY SOURCE. TO REDUCE THE RISK OF ELECTRIC SHOCK, DISCONNECT ALL SUCH CONNECTIONS BEFORE SERVICING.

CAUTION: RISK OF ELECTRIC SHOCK. MORE THAN ONE (1) DISCONNECT SWITCH MAY BE REQUIRED TO DE-ENERGIZE THE EQUIPMENT BEFORE SERVICING.

Thank you for selecting the Raypak Y-200 Series Electronic Boiler Control. It is our sincere hope that you will enjoy its outstanding design, ease of use and energy-saving features.

Please Register

Before proceeding any further, please take a moment to complete the enclosed user registration form and mail a copy to: Raypak, Inc., Department Y-200, 2151 Eastman Avenue, Oxnard, CA 93030.

INTRODUCTION

The Y-200 Series Electronic Boiler Control (controller) is a microprocessor-based boiler management system designed to control either single or multiple stage-fired boilers. Ideally suited for use in hydronic heating and domestic hot water supply applications, this controller has been engineered with the flexibility and raw power to tame the most demanding control situations. Utilizing state-of-the-art control algorithms, the Y-200 Series minimizes operating costs by maximizing energy efficiency.

Concept of Operation

The controller is an outdoor reset control that is perfect for managing hydronic heating systems. Two temperature sensors are used to control system response. One sensor is used to monitor the outdoor temperature, the other sensor is used to regulate the temperature of the system water. By varying the temperature of the heating medium in response to changes in the outdoor temperature, the Y-200 Series provides the ultimate in personal comfort and efficiency of operation.

The controller is also well adapted to domestic hot water supply duty. By disabling the outdoor reset function, the Y-200 behaves as an energy-wise boiler sequencer. With the ability to control multiple firing stages, and such features as a revolutionary selectable lead-lag protocol, the Y-200 redefines "controllability" in domestic water applications.

The controller is equipped with an energy-saving warm-weather shutdown capability. When the outdoor temperature rises above an adjustable "Outdoor Cutoff Temperature," the system automatically transitions to a dormant state. This prevents the system from wasting energy trying to heat a building that is already at a comfortable temperature.

Once the outside temperature has fallen to the point that the system requires heat input to maintain the building temperature, the Y-200 is reactivated and will hold the system temperature at the required point.

For replacement items, see page 38.

Y-200 Controller Configurations

Model No.	Description
Y-241	4-Stage Controller - Includes main controller assembly, air temperature sensor assembly (P/N 068634), water temperature assembly (P/N 068635) and one (1) stage contact board. Main controller includes one (1) mounted auxiliary contacts board.
Y-281	8-Stage Controller - Includes main controller assembly, air temperature sensor assembly (P/N 068634), water temperature assembly (P/N 068635) and two (2) stage contact boards. Main controller includes one (1) mounted auxiliary contacts board.

Table A: Y-200 Controller Configurations

Y-200 Options

Option No.	Description
Y-300	Alarm Bell, 3" diameter. Shipped loose for field installation.
Y-301	Alarm Bell, 4" diameter. Shipped loose for field installation.
Y-302	Second 4-stage Expansion Board. Converts Y-241 to Y-281. Ships loose for field installation.
Y-303	Auxiliary Relay Board. Adds control functions for external equipment such as combustion air louvers. Ships loose for field installation.
Y-304	Slave Cable. Connects slave units to the master controller. Ships loose for field installation.
Y-305	4-20 mA/2-10 VDC Control Board. Accepts 4-20 mA or 2-10 VDC input from external system such as a BMS to force a specific setpoint. Ships loose for field installation. Separate instruction manual; see 5000.64.
Y-306	Inlet/Outlet Sensors. Provides a PAIR of sensors for the inlet and outlet temp. sensing ports. Displays temp. but does not affect control algorithm.
Y-307	LonWorks Module. Provides full communication between a Y-200 series controller and a LonWorks-enabled system. Cannot have BOTH this AND a modem. Shipped loose for field installation. Separate instruction manual; see 5000.63.
Y-308	Modem Module. Provides full communication between a Y-200 series controller and an external system. Cannot have BOTH this AND a LonWorks. Shipped loose for field installation. Separate instruction manual; see 5000.65.

Table B: Y-200 Options

INSTALLATION

If the controller was not mounted on the boiler by the factory, care should be taken to select a suitable mounting location. The controller should be mounted on a solid and permanent base. The unit should be readily accessible for maintenance and installation purposes, and should be mounted so that the display is at a height and location convenient for viewing.

Mechanical Installation

Install the controller within 30 feet of the boiler(s). It must be mounted vertically with the conduit holes facing downward. The conduit holes are sized to accommodate standard 1/2" conduit fittings. If additional or larger conduit fittings are required, locate the conduit connections on the bottom of the module.

Slave units, if present, should be installed adjacent to the master unit. (Y-304 slave cable is approximately five feet long.)

Mount the controller using the mounting bracket and appropriate hardware in four (4) places.

A minimum of eighteen (18) inches clearance from the front, and six (6) inches clearance on all other sides is required for service access. The hinged right side of the box should be installed with sufficient clearance (minimum 3" from bolt hole on the right side) to open the cover.

An electrical distribution sub-panel containing appropriate disconnect switches and surge suppressors is required at or near the equipment location(s).

Electrical Installation

Requires: 120 VAC, Draws 0.5 amp; 60 Hz.

120 VAC Feeder Circuits: Install a surge protection device sized appropriately for your installation at each module.

Install a separate disconnect means for each load. Use appropriately sized wire for equipment as defined by NEC and/or local code. All primary wiring should be no less than 125% of minimum rating.

It is strongly recommended that the controller and the boiler(s) be supplied from the same power source. Install conduit as appropriate.

NOTE: Shielded 18 (AWG) stranded gauge wire must be used to connect the sensors to the controller. The shielded cable should be protected by conduit whenever possible.

NOTE: Minimum 18 AWG, 105°C, stranded wire must be used for all low voltage (less than 30 volts) external connections to the unit. Solid conductors should not be used because they can cause excessive tension on contact points. Install conduit as appropriate. All high voltage wires must be the same size (105°C, stranded wire) as the ones on the unit or larger.

Check Your Power Source

Using a Volt-ohm meter, check the following voltages at the circuit breaker panel:

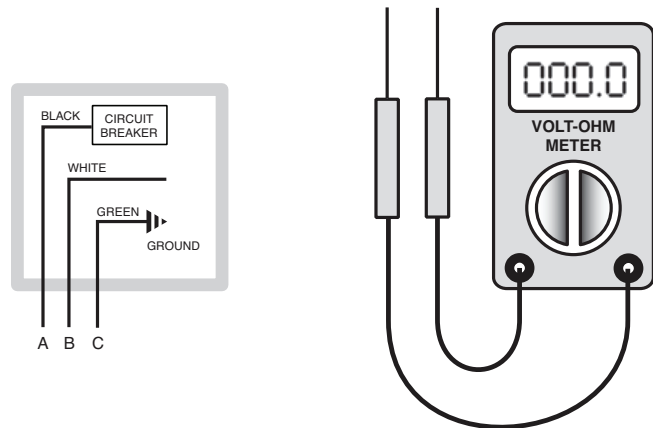

Fig. 1: Volt-ohm Meter

AC = 108 Volts AC Minimum, 132 Volts MAX
AB = 108 Volts AC Minimum, 132 Volts MAX
BC = Must be less than .6 Volts AC

Power to the Controller

- Observe (follow proper) **polarity**.
- Observe proper wire colors while making electrical connections.
- Provide an external surge suppressor capable of maintaining system integrity.
- Provide overload protection and a disconnect means for equipment serviceability as required by local and state code.
- Conduit cannot be used as the ground. (**There must be a "WIRED" ground.**)
- **Very Important:** A grounding electrode conductor shall be used to connect the equipment grounding conductors, the equipment enclosures, and where the system is grounded, the grounded service conductor to the grounding electrode.

Controller Field Wiring

For Single-Stage (ON/OFF) Boilers

All stage connections on the control board are connected at the {TH} (Thermostat) location on the boiler wiring diagram.

For Multiple-Stage Boilers

First stage connections on the control board are connected at the {TH} (Thermostat) location on the boiler wiring diagram. Second (or third, etc.) stage connections on the control board are connected at the locations shown on the boiler wiring diagram.

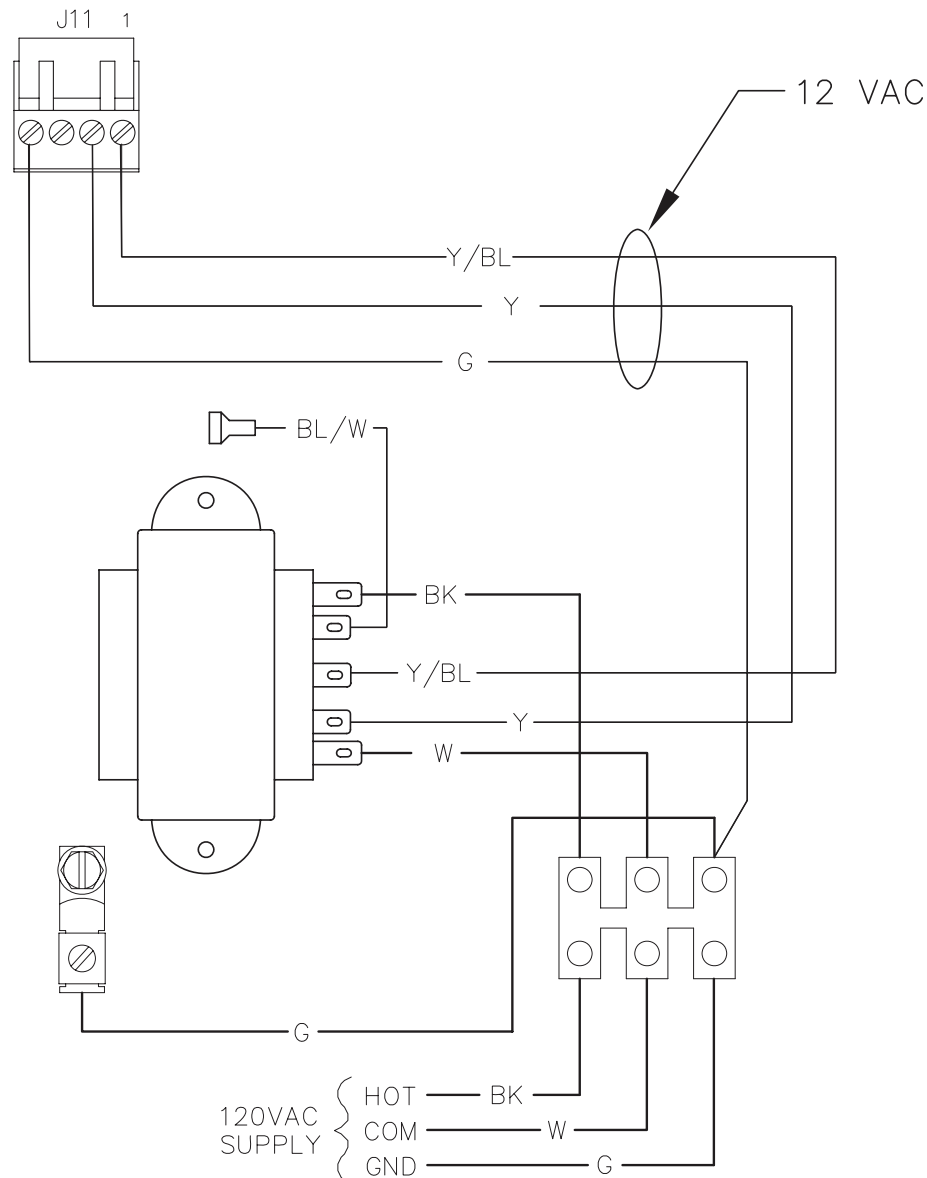

Fig. 2: Wiring Diagram

Notes:

1. Tighten terminal strip clamping screws to 2.5 lbs. Breakage from over-torquing is not covered under warranty.
2. Use stranded copper conductors only. For supply connections, use wires sized on the basis of 60°C (140°F) ampacity and rated a minimum 90°C (194°F).
3. Install disconnect for each control unit.
4. For external building control or thermostat control, remove wiring to J6 (CHF) connector and activate with 12 to 28 VAC.

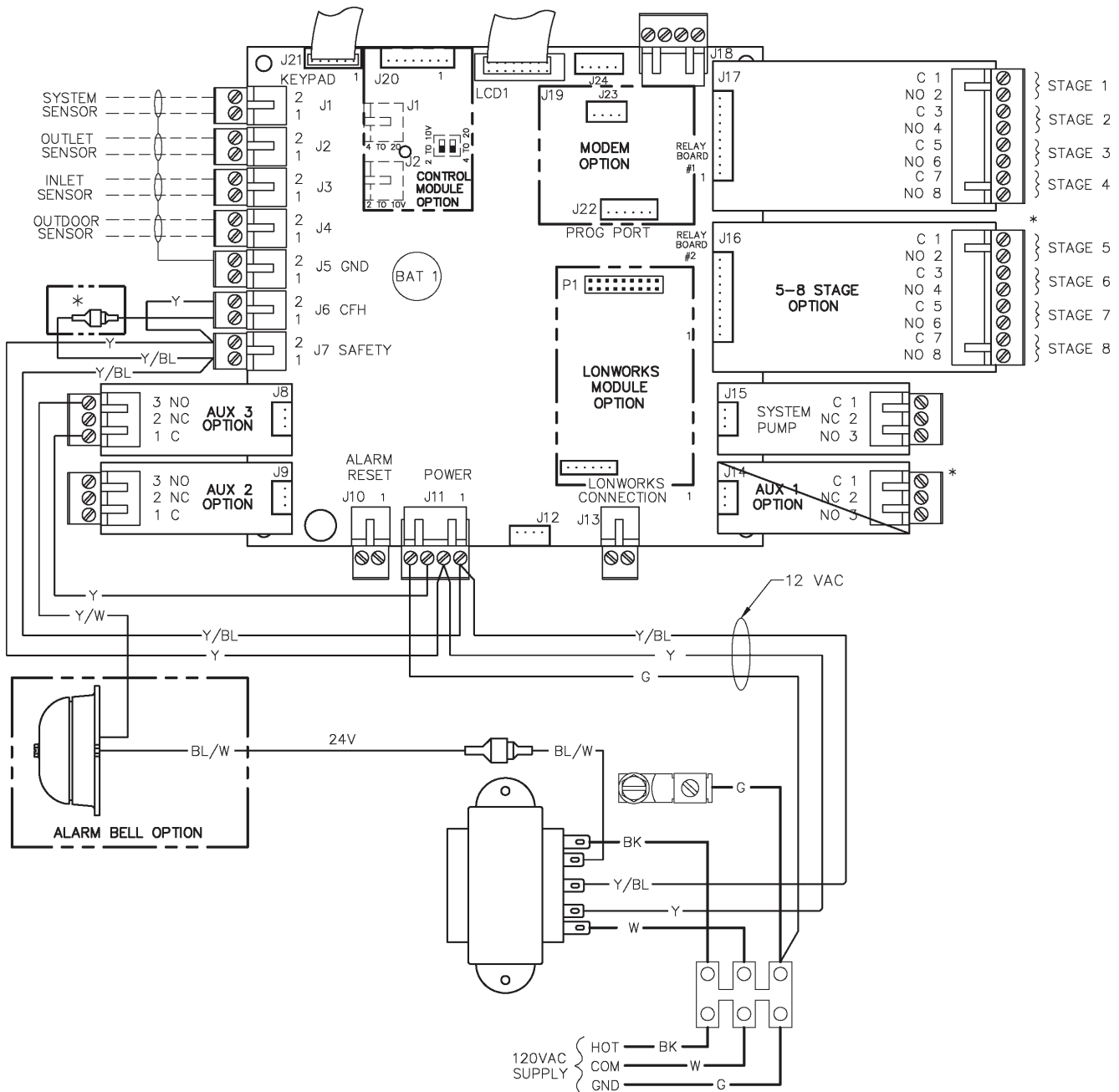

Fig. 3: Wiring Diagram

Communication (RS485) Wiring Required for Optional Slave Unit(s)

Y-304 Slave Cable Installation from System Control Module

- Y-304 slave cable or equivalent shielded communications cable (Belden #9842, Belden #8132 or Alpha 3492C) must be used. Maximum cable length 100 ft. Correct polarity must be observed. Make use of wire color coding to ensure polarity.
- The shielding [foil wrapper-bare wire (drain)] MUST be grounded. Grounding is done at the Master Y-200 Control only. DO NOT ground the shield at the slave unit end of the cable.
- Note: Equivalent shielded cable must be suitable for RS485 communication applications; must have 100-140 ohm impedance and less than 30 picofarad per foot capacitance.
- Must be installed in conduit that does not contain any other wiring.
- Port J18 (see Fig. 4) is used for the interconnection between the master controller and slave units.
- Master/Slave interconnection should be wired from Master to Slave #1, Slave #1 to Slave #2, Slave #2 to Slave #3, and Slave #3 to Slave #4.

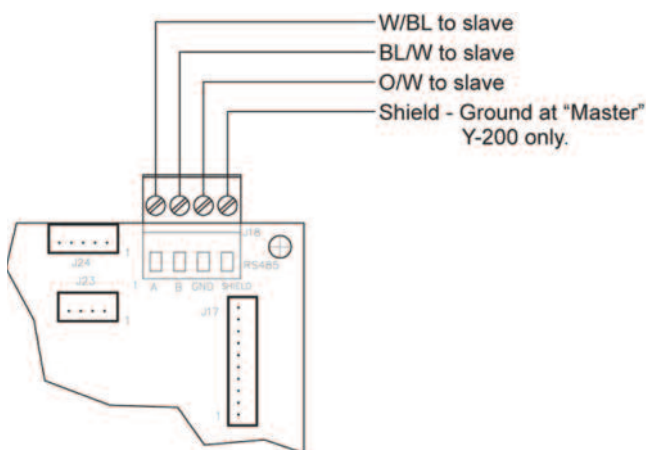

Fig. 4: Master RS485 Communications Cable Schematic

Air Temperature Sensor Installation

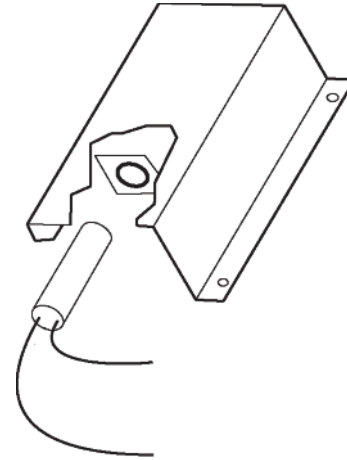

Fig. 5: Typical Outdoor Air Temperature Sensor

- Locate the sensor on the coldest side of building, usually the north side.
- Install the sensor in a shaded area, out of direct sunlight.
- Locate no higher than 2/3 way up the side of the building, or between the 2nd and 3rd floor if the building is more than 3 stories tall.
- Do not locate under an overhang, near wall corners, near drafts from stacks, air moving devices, windows, doors, or balconies.
- Shielded twisted pair (18 AWG) must be used for sensor connections. Polarity must be observed. Cable length shall not exceed 300 feet, and the shielding must be grounded.
- Grounding is done at the Master Y-200 control ONLY. Do Not ground the Slave units or Temperature Sensor enclosure.
- Must be installed with properly-sized conduit that contains no other wiring.
- The outdoor air temperature and water temperature sensor are identical and interchangeable.

Water Temperature Sensor Installation

Hydronic Heating Applications

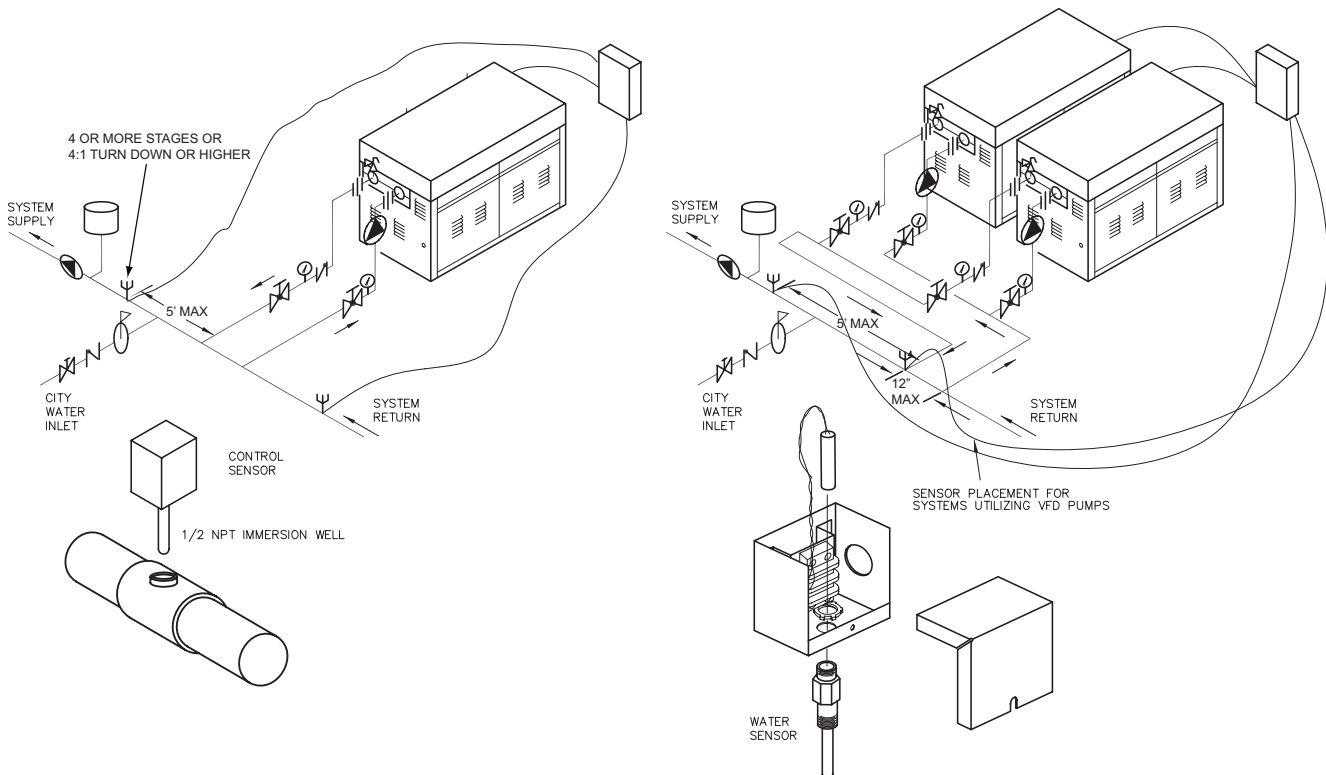

Fig. 6: Typical Water Sensor

- Hydronic installations may require outdoor reset function. See page 11 and screen 02.
- Ensure shielded cable length does not exceed 300 feet. Use 18 AWG shielded wire for sensor connections.
- Must be installed in properly-sized conduit with no other wiring.
- Locate the water sensor as shown in Fig. 6

NOTE: Piping diagrams in this manual are not intended to replace an engineered piping system.

NOTE: When the system involves a variable-speed pump, it is recommended that the temperature sensor be installed in the tee connecting boiler outlet piping to the system. This is to ensure the control can respond to the changing conditions of the system by placing the sensor as close to the blend location as possible and then provide an appropriate and measured response to maintain desired system delivery temperature.

Domestic Hot Water Supply Applications

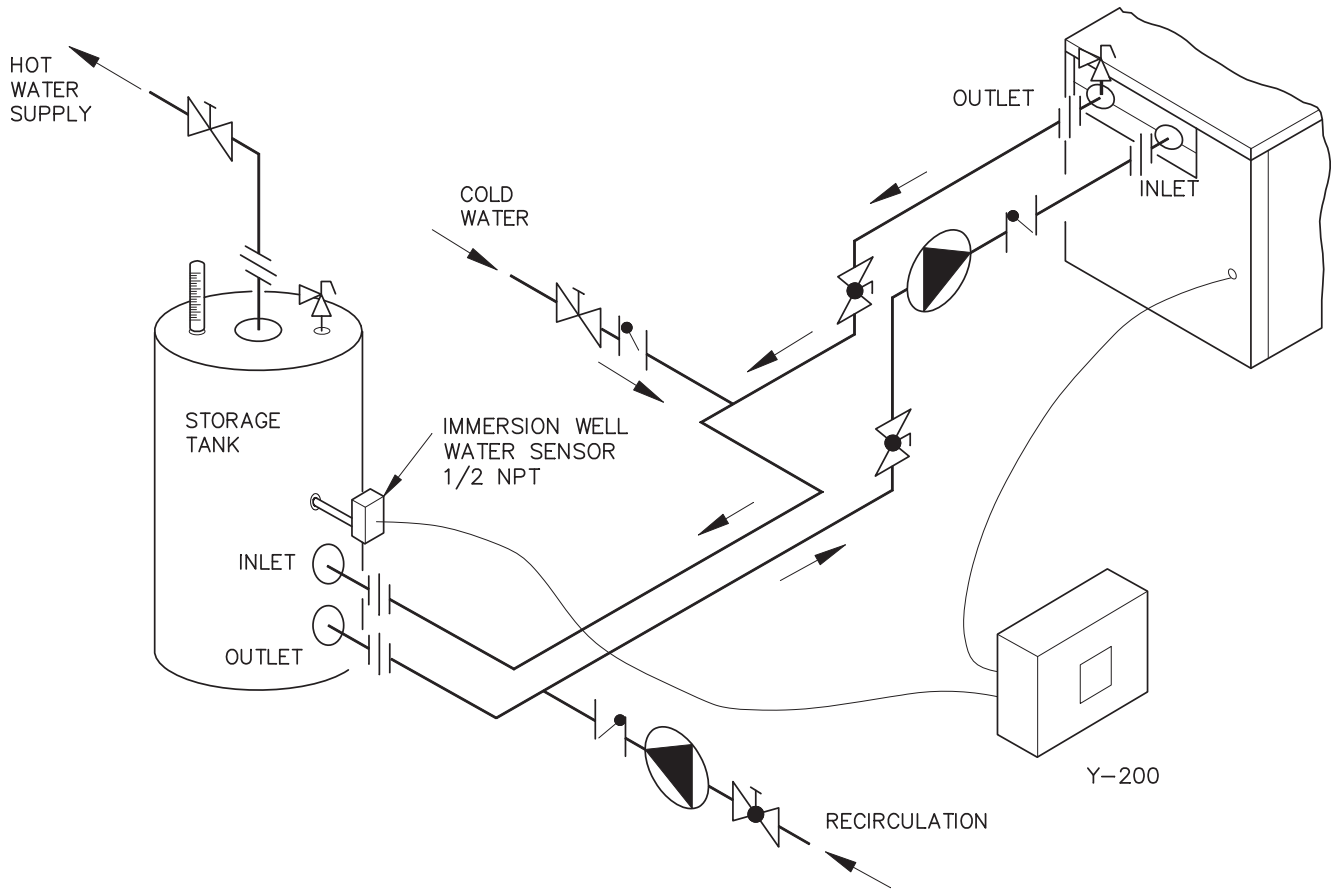

Fig. 7: Domestic Hot Water Supply

- Outdoor reset function should be disabled. See screen 06 and 24.

Power Test

Check Power

Utilizing a Volt-ohm meter (VOM) monitor the following on the controller for proper voltage levels. Check at the Terminal Block (TB-1).

From	To	Indication
TB pin 1	TB pin 2	108 VAC to 132 VAC
TB pin 1	Single Point Ground	108 VAC to 132 VAC
TB pin 2	Single Point Ground	Less than 0.6 VAC

Table C: Voltage Measurements

Installation Verification Procedure

Register

- Before proceeding any further, please verify that the user registration form has been completed and mailed.

Mechanical Installation

- Verify that the mechanical installation has been completed in accordance with the instructions.

Outdoor Air Temperature Sensor

- Verify that all Outdoor Air Temperature Sensor installation parameters have been met.

Water Temperature Sensor

- Verify that the Water Temperature Sensor installation parameters have been met.

Optional Equipment

- Verify that optionally ordered equipment installation parameters have been met.

System Module Installation

- Verify electrical power wiring connections.
- Verify electrical connection torque requirements.
- Verify Outdoor Air Temperature Sensor wiring.
- Verify Water Temperature Sensor wiring.
- Verify Power Test has been completed successfully.

CONTROLLER FAMILIARIZATION

This system is configured utilizing a LCD display (2 lines, 20 characters each) with keypad for data entry. Open the front cover of the Control Box for access to the LCD display and keypad. Open the control panel to gain access to the interface connections.

REFER TO THE TABLES ON THE FOLLOWING PAGES AND THE DISPLAY SCREENS FOR DETAILED CONFIGURATION INSTRUCTIONS.

NOTE: Controller is shipped with factory defaults. Your system may require different program settings.

Control Screens

To access programming mode: Press and hold the "MODE" button for 4 seconds. When in Program mode, cursor is blinking on first settable parameter. UP/DOWN arrows change parameter. LEFT/RIGHT arrows move to next selectable parameter.

NOTE: Once programming is finished, go to Screen 28 to program the USER DEFAULT SET_UP. Then open the front panel and press the SW3 reset button on the motherboard to save the new programming.

SCREEN		DESCRIPTION	FACTORY DEFAULT
Initial Screen	01	Displays the product identification and version of software.	None
Calendar, Time, Initial Setpoint	02	The present month, day, year and time in a 24-hour clock format; setpoint temperature.	None
°F or °C	02	Temperature can be displayed in degrees Fahrenheit or Celsius.	Default Value = °F
Setpoint	02	40 to 220°F (4.4 to 104.4°C); the system output temperature desired when the outdoor temperature is 70°F (21.1°C); or in domestic hot water applications, the desired water temperature.	Default = 140°F (60°C)
Control Band	03	1 to 10°F; the temperature above and below the Target Temperature at which the boiler turns off and on. NOTE: The Control Band is disabled in PID operation. If the Control Band is adjusted during PID operation, it disables the PID function.	Default = 3°F No value when in PID
Offset	04	Degrees of offset added to or subtracted from the initial setpoint at the date and time selected.	Default = OFF
Setting Holiday	05	Data from screen 04 is combined with these screen settings.	Default = 00-00-RH
Reset Ratio	06	None (for Domestic Hot Water Application ONLY) or 0.01:1 to 8:1; determines how much the internally-calculated Target Temperature will change for a given outdoor temperature change.	Default value = 200°F@10°F (93.3°C@-12.2°C)
System Status	07	Shows the status of the system.	None
Water Temperature Limits	08	Maximum "USER" water temperatures 235°F (112.7°C) and Minimum water temperatures 40°F (4.4°C) Display Only.	Max default value = 180°F / 82.2°C Min default value = 105°F / 40.5°C Changes: Screen 23
Outdoor Cutoff Temperature	09	32 to 200°F (0 to 93.3°C), a warm-weather shutdown feature. When the outdoor temperature exceeds this setting, the boiler will not fire unless placed in manual override mode.	Default value = 75°F (23.8°C)
Outdoor Cutoff Deadband	10	-01 to -10°F; the number of degrees below the Outdoor Cutoff Temperature which causes the Outdoor Cutoff Temperature to reset.	Default value = -3°F
System/Network Monitor	11	Displays the Pump, Boiler, Stage and Auxiliary contact status. If flashing, contacts are closed (ON).	This screen is DISPLAY only.
Outdoor Water TAR	12	Displays the current Outdoor Air, System Water and Target Temperature in degrees °F or °C.	Default = °F
AUX Delay	13	000 to 600 seconds; determines when the pump shuts off after entering Outdoor Cut-off mode.	Default = 180 seconds
Boiler/Stage On Delay	14	0 to 600 seconds; sets the time interval between sequential boiler start-ups. 0 to 600 seconds; sets time interval between stages turning on.	Default = 10 seconds Disabled in PID

Table D: Control Screens

SCREEN		DESCRIPTION	FACTORY DEFAULT
Boiler/Stage Off Delay	15	0 to 600 seconds; sets the time interval between sequential boiler start-ups. 0 to 600 seconds; sets time interval between stages turning off.	Default = 10 seconds Disabled in PID
Standard or PID	16	Selects either Standard or PID operation. If PID is selected then PID & Interval is programmable using screen 34.	Default = PID
Boiler Inlet/Outlet Delta(Optional)	17	Displays the boiler inlet and outlet temperature in °F or °C and the difference (delta) between them. (Requires 4-sensor installation, option Y-306.)	INLET / OUTLET = Delta T
Auto Lead-Last	18	The lead change time in hours, the lead and last boiler numbers and the mode (either Auto or Manual).	Manual: Default = 100 hours
Password	19	Used to enter a password. This allows access to screens 20 through 34.	Default = AAA To change: Screen 22
Unit Setup/ Network	20	Sets up the pump, boiler and stage configuration for the System Monitor (Screen 11). Preset = 2 boilers / 4 stages.	Default = PBSSSBSSSAAA Note: See Table I
System Test	21	When ACTIVE, initiates auto system test and displays all screens.	Default = Not Active
Set Password	22	Changes the current user password.	Default = AAA
Water Temperature Limits	23	Sets Maximum and Minimum water temperature limits allowed by the user in the Water Temperature Screen	Min. Default = 105°F (40.5°C), Max. Default = 210°F (98.8°C)
Master/Slave Unit	24	Displays the number of sensors utilized, relays (stages or boilers) and Aux contacts.	Default = Master
Slaves Connected	25	Selects the number of slave units connected, if any.	Default = 00
LonWorks	26	If ON, the LonWorks network will be active.	Default = OFF
Factory Defaults	27	If YES selected, the factory defaults will be restored.	Default = NO
User Defaults	28	If YES is selected, the User Defaults can be stored or invoked.	Default = None
Terminal Password	29	Used to enter a password for modem operation.	Default = AAA
Alarm Call Tele	30	Modem system telephone number to be called when a fault occurs.	None
Alarm Call ID	31	Modem system ID person or place to be called when a fault occurs.	None
Alarm Call Retry	32	Modem system error call retries.	None
Alarm Call Events	33	Modem system error indications.	None
PID Settings	34	Configures PID operation.	Default = Interval = 05 KP = 06 KI = 05 KD = 01

Table E: Control Screens (Continued)

Manual Override

Internal switches have been provided on each of the stage modules that can be used to manually override the microcontroller. See switch SW1 on each stage board, page 15.

Circuit Board Layout

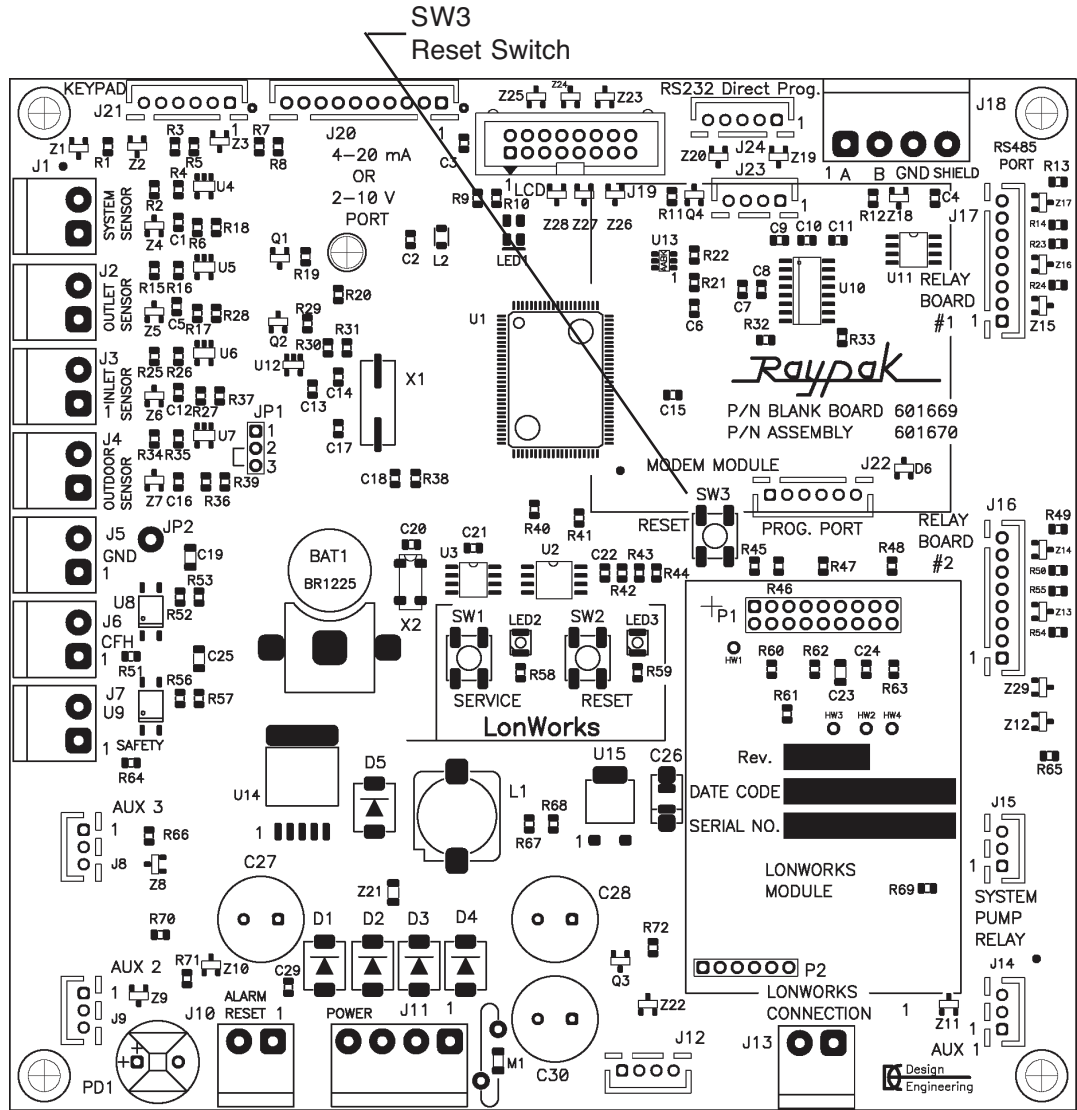

Main Circuit Board

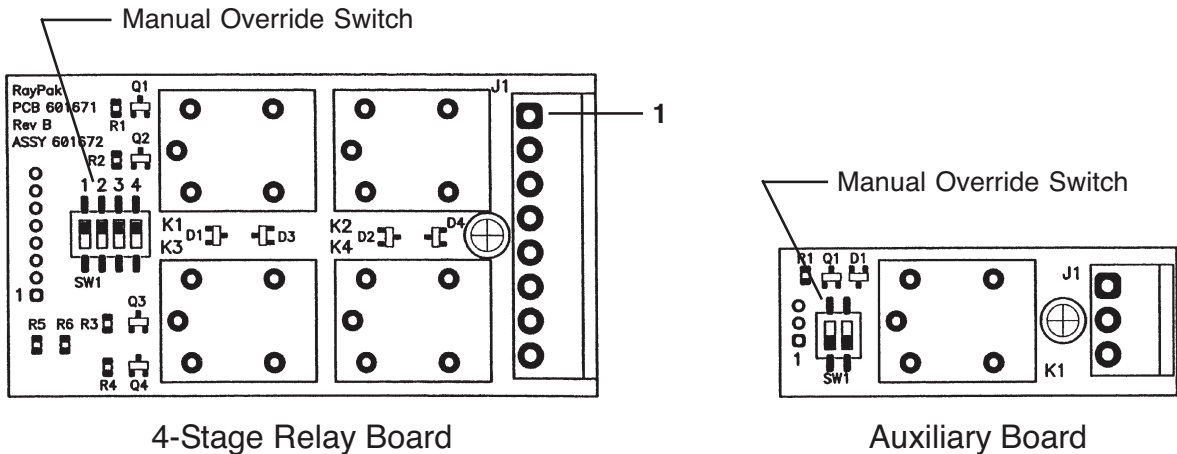

4-Stage Relay Board

Auxiliary Board

Fig. 8: Circuit Board Layout

Keypad

Normal Mode

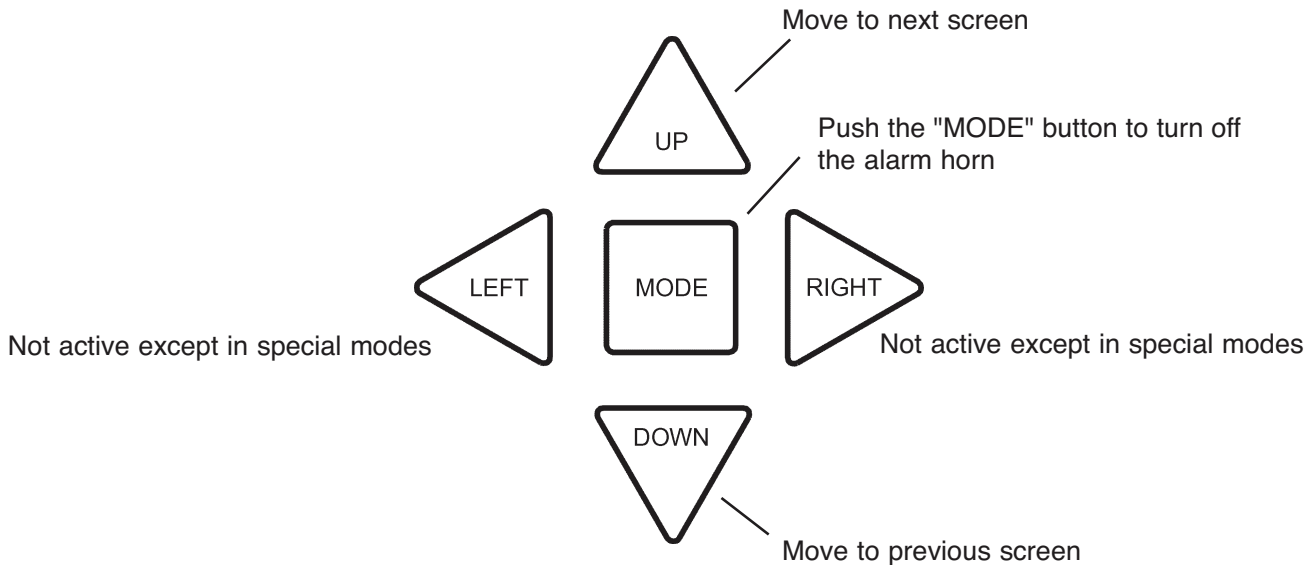

Program Mode

To access programming mode: Press and hold "MODE" button for 4 seconds. If no button is pressed while in PROGRAM mode for 30 seconds, screen returns to normal mode

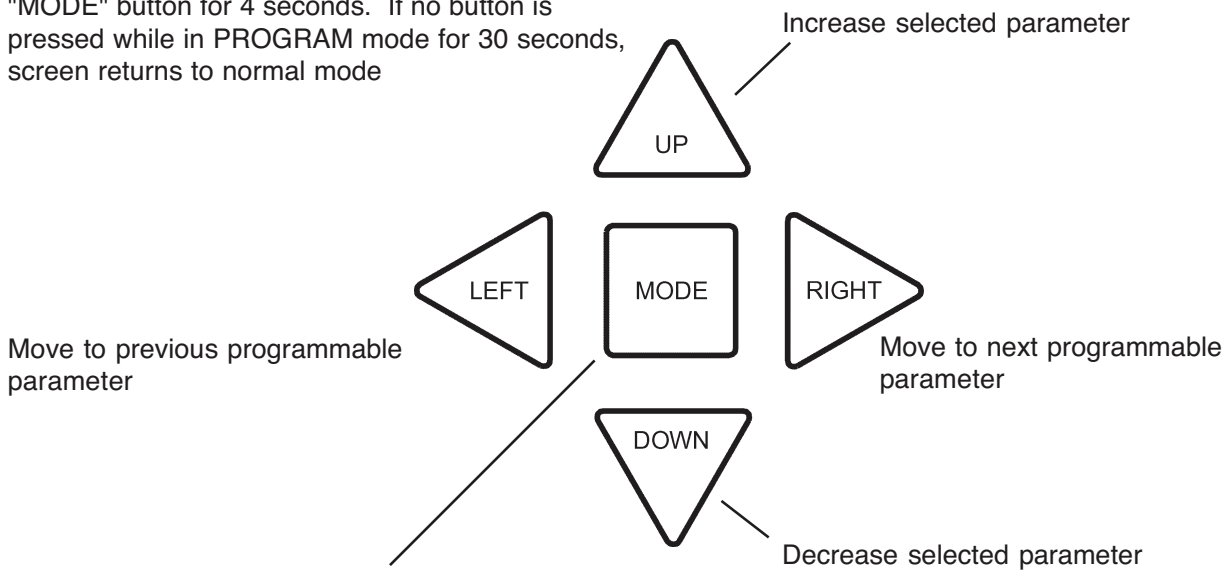

When in PROGRAM mode, cursor is blinking on first settable parameter. If no button is pressed for 30 seconds, screen returns to NORMAL mode. Press "MODE" button to store change and return to NORMAL mode

Once programming is finished, press the SW3 reset button on the motherboard to save the new programming.

Control Screen Displays & Programming

Initial Screen:

R	A	Y	P	A	K		I	N	C								0	1
Y	-	S	E	R	I	E	S		V	E	R		X	X	.	X	X	X

Product identification

Version number of software

Screen number

This is the initial screen displayed after system start-up, provided that there are no faults.

Primary Parameters:

I	N	I	T	I	A	L		S	E	T	P	O	I	N	T	°	F	0	2
M	M	-	D	D	-	Y	Y		H	H	M	M		X	X	X	.	X	°

Calendar:
Month-Day-Year

Current time:
24 hour clock

Fahrenheit or Celsius

System water temperature desired at outdoor temperature of 70°F (21.1°C)
Range: 40°F to 220°F(4.4°C to 104.4°C)
Default Value: 140°F (60°C)

Screen number

Control Band:

Screen number

C	O	N	T	R	O	L			B	A	N	D							0	3
							X	X	.	X	°	F								

*C Band is a range of temperature above and below the target temperature.

Range: 1°F to 10°F (.5°C to 5.5°C)

Default value is 3°F

Fahrenheit or Celsius

Control Band (Proportional Only)

The Control Band sets the maximum temperature above and below the Target Temperature (which is determined by the embedded microcontroller) between which the system temperature may deviate.

This provides a control dead-band that prevents the boiler from short-cycling in proportional mode.

NOTE: The above settings are recommended at initial installation. For maximum performance and system efficiency, these settings should be modified as required to meet such parameters as system capacity, location and usage.

NOTE: The Control Band is disabled when the unit is operating in PID mode.

NOTE: PID mode will be disabled if you adjust the control band.

Offset:

Screen number

O	F	F	S	E	T		O	F	F									0	4

Default "OFF" screen

Press "MODE" to select "OFF" or "ALL" or "FULL WEEK"

Screen number

"ALL" means every day has the same parameters.

O	F	F	S	E	T		A	L	L									0	4
-	-	-		X	:		H	H	M	M			+	X	X	.	X	°	F

There are six offset adjustments allowed for each calendar day.

Time in 24-hour clock mode.

+, blank or -

-99 to 99 degrees of offset. (+) adds to or (-) subtracts from the initial setpoint (screen 02) to become active at selected time.

Fahrenheit or Celsius

Screen number

"FULL WEEK" screen

O	F	F	S	E	T		F	U	L	L		W	E	E	K			0	4
X	X	X		X	:		H	H	M	M			+	X	X	.	X	°	F

There are eight days of selectable offsets:

- MON
- TUE
- WED
- THU
- FRI
- SAT
- SUN
- HOL (Holiday)

+, blank or -

Fahrenheit or Celsius

To set an offset, select the day or choose "ALL" for all days. Set the values in degrees. A positive (+) OFFSET will increase the Water Target Temperature. A negative (-) OFFSET will decrease it. An offset value of 00.0 will return it to its original value.

-99 to 99 degrees of offset are available.

Holiday:

Screen number

S	E	T	T	I	N	G			H	O	L	I	D	A	Y			0	5
H	O	L	#	X	X				X	X	-	X	X	-	X	X			

Thirty two holidays are selectable (01-32)

Month: 01 thru 12

Day: 01 thru 31

Year: 01 to 99; Below 01 is Repeating Holiday (RH) setting

NOTE: Previous screen (04) is used for entering the offset value in degrees.

Reset Ratio:

Ratio of outdoor temperature to water system temperature. Range: .01:1 to 8:1 or "None" for constant water temperature (then TARGET=SETPOINT). Default value is 1.00:1.

Screen number

R	S	T		R	A	T	I	O		X	.	X	X	:	1			0	6
X	X	X	.	X	@	7	0				X	X	X	.	X	@	X	X	

Default:
System temperature at 70°F (21.1°C)
140°F @ 70°F (60°C @ 21.1°C)

Default:
System temperature at °F
This value is 200°F @ 10°F (93.3°C @ -12.2°C)

NOTE: The reset ratio can be modified by changing either the ratio value in line #1 or the system temperature value in line #2.

NOTE: When the reset ratio selected is "NONE", line 2 disappears.

NOTE: Use reset ratio "NONE" when using this controller for domestic hot water or pool applications.

and the second number refers to the degree(s) of change for the water temperature, e.g., a ratio of 2:1 means for every 2° change in outdoor temperature, the System Temperature will change 1°. (The reset temp cannot exceed the temp limits set on screen #08.)

Example: Setpoint = 135°F

The Reset Parameter

Sets the desired change in system water temperature increases as the outdoor temperature decreases. The reset ratio selector is used to determine the rate of change of the boiler(s) output water temperature relative to a change in the outdoor temperature. The first number of the ratio refers to the outdoor temperature

Ratio	Temperature °F	
	Outdoor	System
2:1	70	135
	60	140
	40	150
	20	160

Table F: Outdoor to System Temperature Ratio

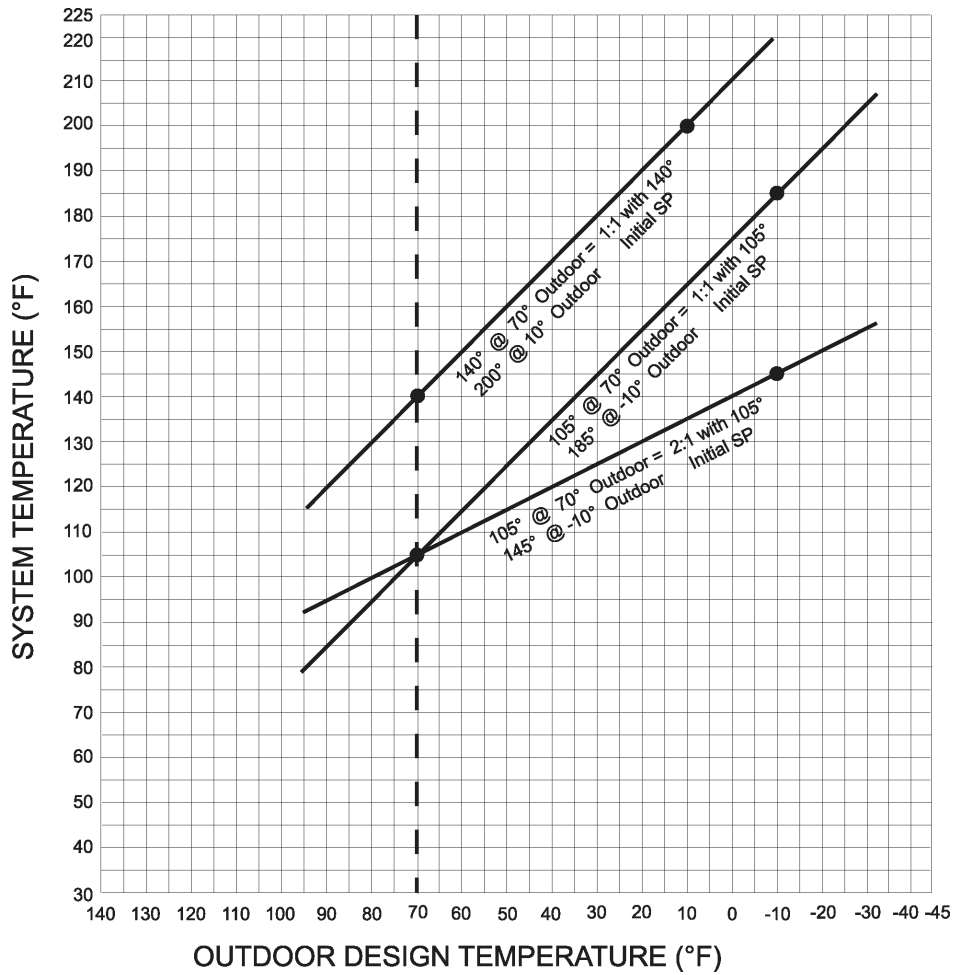

Fig. 10: System to Outdoor Temperature

Radiation	Typical		Reset Ratio Setpoint at Design Temp:			
	Temp @ Design Cond.	Temp @ 70°F	40°F	20°F	0°F	-20°F
Standing	190	105	0.3:1	0.6:1	0.8:1	1.1:1
Convection or Baseboard	200	105	0.3:1	0.5:1	0.7:1	0.9:1
Fan Coil Heating	190	105	0.3:1	0.6:1	0.8:1	1.1:1
Fan Coil Heat and Cool	140	105	0.9:1	1.4:1	2.0:1	2.6:1
Radiant Floor	120	105	2.0:1	3.3:1	4.7:1	6.0:1
Radiant Ceiling	120	105	2.0:1	3.3:1	4.7:1	6.0:1

Table G: Suggested Guidelines

The selection of the correct ratio depends on the initial temperature Set Point set on screen 02 and the desired system water temperature. If the building is too cold, increase the ratio value. After changing the ratio, wait several days and evaluate the comfort level before making another change.

Advanced Programming Feature

Line 2 may be modified by inserting the building design characteristics into the formula. The Reset Ratio will be modified to reflect those characteristics.

NOTE: This information works the same in °C (not shown for clarity).

System Status:

To show the status of other boilers in the system, push either the "LEFT" or "RIGHT" button. If the controller is in a fault condition, the boiler number can be displayed automatically.

NOTE: The alarm horn can be silenced by pushing the mode button.

Screen number

S	Y	S	T	E	M		S	T	A	T	U	S						0	7
S	Y	S	T	E	M		N	O	R	M	A	L							

If more than one ERROR, all errors will be displayed in sequence.

ERROR Indications:

Message	Meaning
NO SAFETY SIGNAL	Safety signal (24VAC) not present on J7 connector
NO CFH SIGNAL	Call-for-heat signal (24VAC) not present on J6 connector
WATER TEMP>MAX	System water temp > Maximum allowed temp
ILS>OLS	Inlet water temp > Outlet water temp
SYS IS OPEN	System water sensor or cable/connector is open
SYS IS SHORT	System water sensor or cable/connector is shorted
OLS IS OPEN	Outlet water sensor or cable/connector is open
OLS IS SHORT	Outlet water sensor or cable/connector is shorted
ILS IS OPEN	Inlet water sensor or cable/connector is open
ILS IS SHORT	Inlet water sensor or cable/connector is shorted
OSS IS OPEN	Outdoor air sensor or cable/connector is open
OSS IS SHORT	Outdoor air sensor or cable/connector is shorted

Table H: Error Indications

W	A	T	E	R		T	E	M	P									0	8
M	A	X	:	X	X	X	.	X			M	I	N	:	X	X	X	.	X

Screen number

Displays the maximum water temperature for the boiler. Range is determined by screen number 23. Factory default is 180°F (82.2°C) Maximum.

Displays the minimum water temperature for the boiler. Range is determined by screen number 23. Factory default is 105°F (40.5°C) Minimum.

O	U	T	D	O	O	R		C	U	T	O	F	F					0	9
T	E	M	P				X	X	X	.	X	°	F						

Screen number

Fahrenheit or Celsius

The outdoor cut-off sets the maximum outdoor temperature at which heat is desired. This control sets the outdoor temperature above which the boiler bank is disabled. If the outdoor temperature increases beyond the outdoor cut-off setting, there is no call for heat and the pump turn off delay becomes active. If the outdoor temperature falls below the outdoor cut-off minus the outdoor cut-off Deadband the boiler bank will again be enabled.

The Outdoor cut-off Temperature is from 32°F to 200°F (0°C to 93.3°C).
 Recommended Initial Setting for outdoor cut-off Temperature is 75°F (23.8°C).
 Factory default is 75°F (23.8°C).

Outdoor Cut-Off Deadband:

O	U	T	D	O	O	R		C	U	T	O	F	F					1	0
D	E	A	D	B	A	N	D				-	X	X	.	X	°	F		

Screen number

Fahrenheit or Celsius

The Outdoor cut-off deadband sets the number of degrees below the outdoor cut-off where the outdoor cut-off reset occurs. The outdoor cut-off deadband limit is -1 degree F to -10 degrees F. Default is -3 degrees F.

Note: This parameter can only be set in °F, but will display in °C if °C is chosen.

System Monitor:

Screen number

S	Y	S	T	E	M		M	O	N	I	T	O	R					1	1
M	A	S	T	E	R			P	B	S	S	S	B	S	S	S	A	A	A

This screen is only a display.

Total # of stages available is set on screen 24.

P=	SYSTEM PUMP MODULE Rule: Always on before boiler. Always off after last boiler off + programmed delay. P is relay #1 as supplied.
B=	INDICATES BOILER - 1st Stage Rule: Always B before S
S=	INDICATES BOILER STAGE - 2nd Stage and Subsequent Stages Rule: Must have "B" for that boiler ON and prior stages ON for that boiler.
A=	AUXILIARY RELAY MODULE Optional: A1 - User-defined function. (e.g. powered louvers, boiler pump, draft fan) A2 - User-defined function. (e.g. alarm light) A3 - User-defined function. (e.g. alarm bell)

Table I: Definitions

System Pump: "NO SCREEN"

The System Pump Relay works in conjunction with the "OUTDOOR CUT-OFF TEMPERATURE".

System Temperatures:

Screen number

O	U	T	D	O	O	R		W	A	T	E	R		T	A	R		1	2
	X	X	X	.	X			X	X	X	.	X		X	X	X	.	X	

Current outdoor air temperature
Displays 000.0
if no sensor is present

Current System Water Temperature

Target temperature
System design temperature
If system has reached "Outdoor Cut-off" temp [TAR=0]

Auxiliary Delay:

Screen number

A	U	X		D	E	L	A	Y									1	3
						X	X	X		S	E	C						

Auxiliary Delay

When CFH signal is "ON" the relay contact of the A1 Auxiliary module stays closed. When the CFH signal changes to "OFF," the contacts of the relay stay closed as long as the delay is set up.

The AUX contacts operate on a delay after CFH.

AUX turnoff range is 0 to 600 seconds. The default value is 180 seconds.

NOTE: If the "Call-for-Heat" (CFH) or "Safety" signal is removed from the Y-200, the pump delay will time out and open the auxiliary contact.

INSTALLERS NOTE: If the end user requires the "System Pump" to be turned off if the "CFH" or "Safety" signal is removed, it is recommended that the system pump be operated from the "Aux 1 Relay," to provide a delay on turn off.

Boiler/Stage ON Delay:

NOTE: Refer to screen number 16 (standard)

Screen number

B	O	I	L	R	/	S	T	G		O	N		D	L	Y			1	4
X	X	X		S	E	C					X	X	X		S	E	C		

Boiler Turn-On Delay

In a multiple boiler system: The boiler Turn-On Delay sets the amount of delay before each additional boiler is turned on in response to a call for heat. This delay starts when the preceding boiler is turned on.

The Boiler Turn-On Delay range is from 0 to 600 seconds. Recommended Initial Setting for Boiler Turn-On Delay is 30 seconds.

Factory default is 30 seconds.

Stage Turn-On Delay

The Stage Turn-On Delay sets the time delay before a new stage in a multi-stage boiler configuration is turned on. This delay starts when the stage or boiler preceding the next stage is turned on.

The Stage Turn-On Delay range is from 0 to 600 seconds.

Recommended Initial setting stage for Turn-On Delay is 10 seconds.

Factory default is 10 seconds.

Boiler/Stage Off Delay:

Screen number

B	O	I	L	R	/	S	T	G		O	F	F		D	L	Y		1	5
X	X	X		S	E	C					X	X	X		S	E	C		

Boiler Turn-Off Delay

In a multiple boiler system: The boiler Turn-Off Delay sets the amount of delay before each additional boiler is turned off. This delay starts when the preceding boiler is turned off.

The Boiler Turn-Off Delay range is from 0 to 600 seconds.

Recommended Initial setting for Boiler Turn-Off Delay is 30 seconds.

Factory default is 30 seconds.

Stage Turn-Off Delay

The Stage Turn-Off Delay sets the time delay before a stage in a multi-stage boiler configuration is turned off. This delay starts when the stage or boiler preceding the next stage is turned off.

The Stage Turn-Off Delay range is from 0 to 600 seconds.

Recommended Initial setting stage for Turn-Off Delay is 10 seconds.

Factory default is 10 seconds.

Proportional Integral Derivative (PID):

Screen number

P	I	D		C	=	X	X	X			S	=	X	X				1	6
P	=	X	X	X			D	=	X	X	X			I	=	X	X	X	

NOTE: PID mode is the logic control for the micro-processor; disables screens 3, 14 and 15.

Standard:

This is the factory default screen.

Screen number

S	T	A	N	D	A	R	D											1	6

Standard mode is controlled by:
 Screen 3: Control Band
 Screen 14: Time On Delay
 Screen 15: Time Off Delay

System Temperatures:

These screen parameters are only available if the inlet and outlet sensors have been installed and selected. See screen 24.

This screen is only a display.

I	N	L	E	T		O	U	T	L	E	T		D	E	L	T	A	1	7
	X	X	X	.	X		X	X	X	.	X		X	X	X	.	X		

Screen number

Current boiler inlet or system temperature*

Current boiler outlet or system temperature*

Boiler or System delta.*

NOTE: 1. These values are currently reserved for viewing actual and delta temperatures. 2. If the sensors are not selected or used, dashes (-) will be displayed.

Lead Change Time:

Auto or Manual

A	U	T	O				L	E	A	D	-	-	L	A	S	T		1	8
1	0	0	-	0	4	4		#	X	X				#	X	X			

Screen number

If manual lead change hours
(Displayed in manual)

Run time

Lead boiler

Last boiler

For Manual Only:

Lead Change Hours

Designated lead boiler will change when remaining hours reaches 0. Range 0-999 hours. Default value is 100 hours. If set at 0 hours lead will not change. Hours remaining will automatically total. Enter the desired number of hours for the lead boiler operation before change. Hours remaining are automatically calculated.

For Auto Only:

On multiple boiler systems and on each new firing cycle, the lead boiler will change. If a "Last Boiler" is selected, it will always be the last boiler to be called for during a heating cycle.

Password:

Screen number

		P	A	S	S	W	O	R	D									1	9
												A	A	A					

Used by maintenance personnel to change settings.

In display mode shows AAA or current password.

To enter the password:

1. Push the mode key. The cursor under the first A should start flashing.
2. Change the first letter by using the up or down key to the desired letter. Use the right key to go to the next letter and change it with the up or down key. Do the same to the last letter then push the mode key when done.
 - If the password is valid, the screen will allow the user to change to the first setup screen.

Setup:

Screen number

U	N	I	T		S	E	T	-	U	P								2	0
M	A	S	T	E	R			P	B	S	B	S	B	S	S	S	A	A	A

P=	SYSTEM PUMP MODULE Rule: Always on before boiler. Always off after last boiler off + programmed delay. P is relay #1 as supplied.
B=	INDICATES BOILER Rule: Always B before S
S=	INDICATES BOILER STAGE Rule: Must have "B" for that boiler ON and prior stages ON for that boiler.
A=	AUXILIARY RELAY MODULE Optional: A1 - User defined function. (i.e. powered louvers, boiler pump, draft fan) A2 - User defined function. (i.e. alarm light) A3 - User defined function. (i.e. alarm bell) NOTE: Piezo-electric alarm horn can be silenced by pressing the "MODE" switch.

Table J: Definitions

System Test:

Screen number

S	Y	S	T	E	M		T	E	S	T								2	1
				N	O	T		A	C	T	I	V	E						

or ACTIVE

This display will cycle between turning all LCD segments on for four (4) seconds then off for four (4) seconds. To stop this cycling push any button. Self-diagnostics are initiated at 0900 and 1900 hours.

NOTE: 1) When system test is running, this will not affect control or boiler operation. 2) If system test is running, it can be terminated by pushing any button.

Set Password:

Screen number

			S	E	T			P	A	S	S	W	O	R	D			2	2
												A	A	A					

In display mode shows AAA or current password.

To change the default password AAA to a new password:

1. Push the mode key. The cursor under the first A should start flashing.
2. Change the first letter by using the up or down key to the desired letter.
3. Use the right key to go to the next letter and change it with the up or down key.
4. Do the same to the last letter then push the mode key when done.

Water Temperature Limits:

Screen number

W	A	T	E	R		T	E	M	P		L	I	M	I	T	S		2	3
M	A	X	:	X	X	X	.	X			M	I	N	:	X	X	X	.	X

Maximum programmable setting is 235°F (112.7°C).
Factory default value is 210°F(98.8°C).

Minimum programmable setting is 40°F (4.4°C).
Factory default value is 105°F (40.5°C).

NOTE: This screen sets the maximum and minimum values allowable by the user. The values entered in user screen number 8 cannot exceed the maximum and minimum values programmed here.

Master Unit:

M	A	S	T	E	R													2	4
S	N	S	:	X		R	E	L	A	Y	:	X		A	U	X	:	X	

Screen number

0, 1, 2 or 4
Number of temp. sensors.

1 thru 8
Number of staging contacts in use. See screen 25.

0, 1, 2 or 3
Number of auxiliary boards in use.

If SNS:0

This unit is a slave unit (No sensors required or active)

If SNS:1

Water (System) - Turn outdoor reset ratio to "NONE" on screen 06.

If SNS:2

Water & Outdoor (Activates outdoor reset function on screens 6, 9 and 10.)

If SNS:4

Water, Outdoor, Inlet, Outlet (Activates screen 17.)

This screen limits the programmable parameters available to the user. The information provided is determined by boiler and control construction.

Stage/Sensor Connections for Y-200 Master/Slave Systems

Total no. of stages	Master unit		Slave 1		Slave 2		Slave 3	
	Relay boards	sensors	Relay boards	sensors	Relay boards	sensors	Relay boards	sensors
01 - 04	1	*						
05 - 08	1 & 2	*						
09 - 12	1 & 2	*	1	none				
13 - 16	1 & 2	*	1 & 2					
17 - 20	1 & 2	*	1 & 2					
21 - 24	1 & 2	*	1 & 2					
25 - 28	1 & 2	*	1 & 2		1	none		
29 - 32	1 & 2	*	1 & 2		1 & 2			
33 - 36	1 & 2	*	1 & 2		1 & 2		1	none
37 - 40	1 & 2	*	1 & 2		1 & 2		1 & 2	
					1 & 2			

* As required for the installation. See above section.

Table K: Connections for Master/Slave Systems

NOTE: The unit with sensors installed is identified as the master unit.

NOTE: The maximum is 4 sensors and 4 slave controllers.

Slave Unit:

See Staging Table

S	L	A	V	E	S		C	O	N	N	E	C	T	E	D			2	5
					#	X	X												

Screen number

Number of slaves connected: 01 thru 04

A unit with no sensors attached to it defines itself as the SLAVE unit.

In program mode (see page 32) you identify which SLAVE unit you want it to be.
SLAVE units are numbered from 1 to 4.

Connect the master unit to each slave unit in parallel using RS485 wiring as noted in the Communications (RS485) Wiring section of this manual.

LonWorks:

L	O	N	W	O	R	K	S											2	6
O	F	F																	

Screen number

If ON, the LonWorks network is active.

Factory Defaults:

F	A	C	T	O	R	Y			D	E	F	A	U	L	T	S			2	7
									N	O										

Screen number

Press MODE button to get into program mode.
Press UP arrow key to select YES.
Press MODE button to load Factory Defaults and to exit program mode.
NOTE: If unit times out, the factory defaults will not be set.

Screen number

F	A	C	T	O	R	Y			D	E	F	A	U	L	T	S		2	7
									N	O									

Press MODE button to get into program mode.
 Press UP arrow key to select YES.
 Press MODE button to load Factory Defaults and to exit program mode.
 NOTE: If unit times out the factory defaults will not be set.

Screen number

	U	S	E	R					D	E	F	A	U	L	T	S		2	8
N	O	N	E						N	O		D	E	F	A	U	L	T	

Press MODE button to get into program mode.

Screen number

	U	S	E	R					D	E	F	A	U	L	T	S		2	8
S	E	T	U	P				D	E	F	A	U	L	T	S				

Used to store setup parameters.

Screen number

	U	S	E	R					D	E	F	A	U	L	T	S		2	8
I	N	V	O	K	E			D	E	F	A	U	L	T	S				

Press UP or DOWN key to select "Setup Defaults" or "Invoke Defaults". Used to restore setup parameters.
 Press MODE button to exit program mode.

	T	E	R	M	I	N	A	L		P	A	S	S	W	D			2	9
												X	X	X	X				

Press MODE button to get into program mode.
 Enter password
 Press MODE button to exit program mode.

Alarm Call Telephone:

Screen number

A	L	A	R	M		C	A	L	L		T	E	L	E				3	0
X	X	X	X	X	X	X	X	X	X	X	X	X	X	X	X				

Used to enter telephone number to be called when a fault occurs.

Alarm Call ID:

Screen number

A	L	A	R	M		C	A	L	L		I	D						3	1
X	X	X	X	X	X	X	X	X	X	X	X								

Used to identify person or place to be called when a fault occurs.

Alarm Call Retry:

Screen number

A	L	A	R	M		C	A	L	L		R	E	T	R	Y			3	2
X	X			S	Y	S	T	E	M		I	D	L	E	.	.	.		

Used to set the number of times (00 to 20) you want the unit to keep calling out when a fault occurs.

Alarm Call Events:

Screen number

A	L	A	R	M		C	A	L	L		E	V	E	N	T	S		3	3
A	A	A	A	A	A	A	A	A	A	A	A	A		X	X	X	X	X	X

Enable or disable system error indications.

Factory default: Enable
 Press and hold MODE button to access system error indications.

PID

Proportional - Integral - Derivative Control

Interval - time in seconds that the PID updates

KP - Proportional control (01 - 30) - Band in degrees above and below setpoint

KI - Integral control (01 - 99) - Adjustable in % 0.0 - 1.0

KD - Derivative control (01 - 99) - Adjustable in % 0.0 - 10.0

PID Interval:

NOTE: Refer to screen number 34 (PID)

Screen number

P	I	D			I	N	T	E	R	V	A	L		X	X			3	4
K	P		X	X			K	I		X	X			K	D		X	X	

Default Values: Interval=05; KP=06; KI=05; KD=01

NOTE: DO NOT change the default values unless directed to do so in consultation with factory technical support. Changing of these parameters may create adverse operating conditions.

Master Unit with Slaves

Refer to page 36 for the Master/Slave diagram.

Press MODE button to get into program mode.

Go to screen number 25 and select the number of slaves you wish to use, 01 thru 04.

Screen number

S	L	A	V	E	S		C	O	N	N	E	C	T	E	D			2	5
					#	X	X												

Go to screen number 24 and select the number of sensors, relays and auxiliaries.

Screen number

M	A	S	T	E	R													2	4
S	N	S	:	X		R	E	L	A	Y	:	X		A	U	X	:	X	

Go to screen number 20 and set up your Network master and slave operations.
(Setup slave operations prior to Network Set-up on Master Controller.)

Screen number

N	E	T	W	O	R	K		S	E	T	-	U	P					2	0
M	A	S	T	E	R			P	B	X	X	X	X	X	X	X	X	X	X

Screen number

N	E	T	W	O	R	K		S	E	T	-	U	P					2	0
S	L	A	V	E	:	1		R	:	X		X	X	X	X	X	X	X	X

Screen number

N	E	T	W	O	R	K		S	E	T	-	U	P					2	0
S	L	A	V	E	:	2		R	:	X		X	X	X	X	X	X	X	X

Screen number

Go to screen number 11 and it should cycle thru your complete setup.

N	E	T		M	O	N		C	B	0	9		C	5	0	3		1	1	
X	X	X	X	X	X	X	X	X	X	X	X	X	X	X	X	X	X	X	X	X

Slave Unit:

Screen number

Press MODE button to get into program mode.
Go to screen number 25 and display should read.

S	L	A	V	E	S		C	O	N	N	E	C	T	E	D			2	5	

Go to screen number 24 and select the number of sensors, relays and auxiliaries.

NOTE: On slave unit select 0 for number of sensors.
Select which slave number you wish it to be, 01 through 04.

Screen number

S	L	A	V	E			#	X	X									2	4
S	N	S	:	0		R	E	L	A	Y	:	X		A	U	X	:	X	

Screen number

Go to screen number 20 and set up your unit operations.

U	N	I	T		S	E	T	-	U	P								2	0
S	L	A	V	E				P	B	X	X	X	X	X	X	X	X	X	X

Ignore screen number 11 on the slave units.

Y-200 Master/Slave Diagram

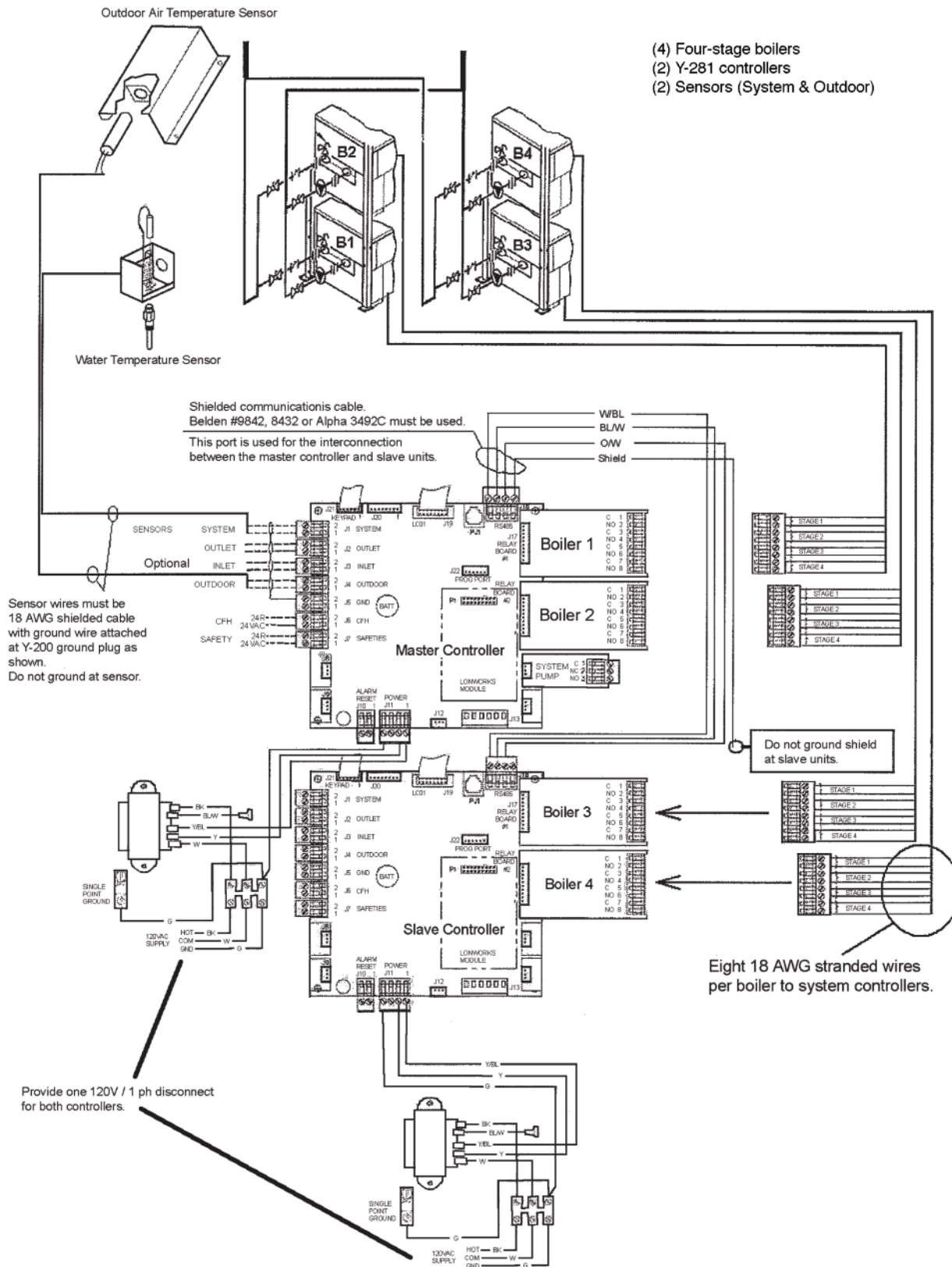

Sensor Resistance at Various Temperatures

If a sensor error is suspected, perform the following:

1. Examine the wiring, ensuring continuity from controller to sensor(s).
2. Using a multimeter, measure resistance of sensor(s) and compare the value with the Table L below.
3. If all okay, replace main control board.

Temperature (°F)	Resistance (K Ohms)
-20	1666.3
-10	1193.1
0	863.6
10	631.7
20	466.7
30	348.0
40	262.0
50	199.0
60	153.6
70	119.4
80	93.5
90	73.8
100	58.6
110	46.9
120	37.7
130	30.5
140	24.9
150	20.5
160	16.9
170	14.1
180	11.7
190	9.9
200	8.3
210	7.0
220	6.0

Table L: Sensor Resistance at Various Temperatures

Y-200 Illustrated Parts List

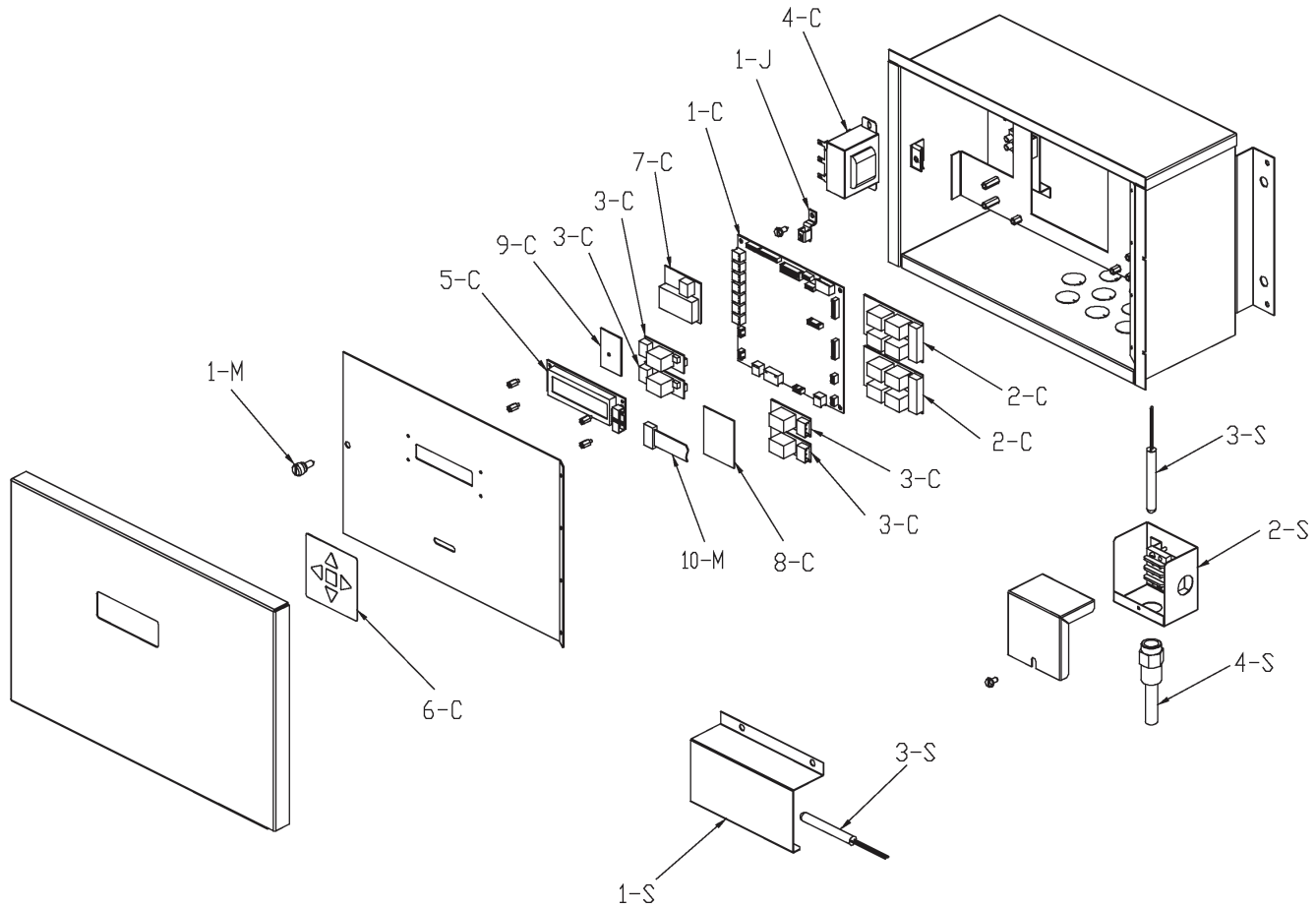

Item No.	Description	Part No.
1-C	PC Board Assy, Y-200	008846F
2-C	Expansion Board Assy, 4-Stage	008847F
3-C	Auxiliary Board Assy	008848F
4-C	Transformer Assy	008705F
5-C	LCD Display Assy	012662F
6-C	Control Keypad	008850F
7-C	Modem Module	010792
8-C	Lon Works Module	010791
9-C	4-20 MA/2-10 VDC Module	009823
1-J	Wire Bonding Connector	007155F
1-S	Air Temp Sensor Assy	008828F
2-S	Water Temp Sensor Assy	008829F
3-S	Air/Water Temp Sensor	008845F
4-S	Well Assy	004821F
1-M	Retainer and Screw	006744F
2-M	Control Mtg	013435F
10-M	Ribbon Cable Display	011715F

**LIMITED WARRANTY
Y-200 Series**

SCOPE OF WARRANTY :

Raypak, Inc. ("Raypak") warrants to the original owner the Control System to be free from defects in materials and workmanship under normal use and service for the applicable warranty period. In accordance with the terms of this Limited Warranty, RAYPAK will furnish a replacement or repair, at our option, any defective part which fails in normal use and service during the applicable warranty period. The replacement or repair will be warranted for only the unexpired portion of the original Warranty Period.

APPLICABLE WARRANTY PERIOD

The effective date of warranty coverage is the date of original installation, of the Control System, by a qualified electrician or by a RAYPAK authorized service technician. The Applicable Warranty Period is one (1) year from the effective date.

WARRANTY EXCLUSIONS

This Limited Warranty does not apply:

1. if the control system is not properly installed by a qualified technician in accordance with manufacture's installation instructions, applicable codes, ordinances and good trade practices,
2. to damage or malfunctions resulting from failure to properly install, operate or maintain the system in accordance with the manufacture's instructions;
3. if the rating plate(s) or serial number(s) are altered, defaced or removed;
4. if the System is modified in any way or used with any non-factory authorized accessories or components;
5. to damage or failure from abuse, accident, act of nature, fire, flood, freezing or the like;
6. to accessories, rubber or plastic parts, light bulbs or glass parts;
7. if the System is moved from its original installation site; or if the original owner no longer owns the site or the System.

LABOR AND SHIPPING COSTS

This Limited Warranty does not cover labor costs for service, removal or reinstallation of any part nor shipping charges to or from RAYPAK'S designated repair center or to or from the installation site. All such costs are your responsibility.

HOW TO MAKE A WARRANTY CLAIM

To make a warranty claim, promptly ship (postage prepaid) or carry the defective part to a designated RAYPAK Service Dealer or Service Station in the United States, supplying proof of purchase and date of installation and the model and serial numbers. If you cannot locate a dealer, contact RAYPAK'S Service Department at the address/telephone listed below. Raypak reserves the right at all times to inspect the claimed defect and verify warranty coverage at its factory.

EXCLUSIVE WARRANTY - LIMITATION OF LIABILITY

This is the only warranty given by RAYPAK. No one is authorized to make any other warranties on Raypak's behalf. **ANY IMPLIED WARRANTIES, INCLUDING MERCHANTABILITY OR FITNESS FOR A PARTICULAR PURPOSE, SHALL NOT EXTEND BEYOND THE APPLICABLE WARRANTY PERIOD SPECIFIED ABOVE. RAYPAK'S SOLE LIABILITY WITH RESPECT TO ANY DEFECT SHALL BE AS SET FORTH IN THIS LIMITED WARRANTY. ANY CLAIMS FOR INCIDENTAL OR CONSEQUENTIAL DAMAGES (INCLUDING DAMAGE FROM WATER LEAKAGE) ARE EXCLUDED.** Some states do not allow limitations on how long an implied warranty lasts, or for the exclusion of incidental or consequential damages, so the above limitation or exclusion may not apply to you.

THIS LIMITED WARRANTY GIVES YOU SPECIFIC LEGAL RIGHTS, AND YOU MAY ALSO HAVE OTHER RIGHTS WHICH VARY FROM STATE TO STATE.

We suggest you immediately complete the information below and retain this Limited Warranty Certificate in case warranty service is needed.

RAYPAK, INC. SERVICE DEPARTMENT

2151 Eastman Avenue, Oxnard, California 93030

Telephone: (805) 278-5300 FAX (805) 278-5468

The following information must be provided when you write or call:

Original Owner

Daytime Telephone Number

Complete Mailing Address

City

State

Zip Code

Installation Site

Model Number

Contractor/Installer

Date of Installation

Serial Number



Raypak, Inc., 2151 Eastman Avenue, Oxnard, CA 93030 (805) 278-5300 Fax (805) 278-5495
Litho in U.S.A.