

INSTALLATION AND OPERATION INSTRUCTIONS

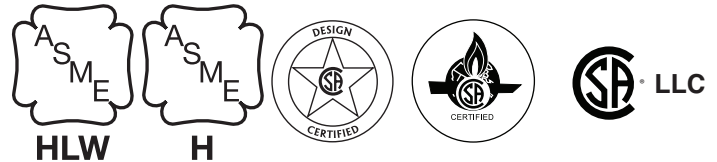

Models 992C–2342C

Types H, WH & P



▲ WARNING: Improper installation, adjustment, alteration, service, or maintenance can cause property damage, personal injury, exposure to hazardous materials*, or loss of life. Review the information in this manual carefully. *This unit contains materials that have been identified as carcinogenic, or possibly carcinogenic, to humans.

FOR YOUR SAFETY: Do not store or use gasoline or other flammable vapors and liquids or other combustible materials in the vicinity of this or any other appliance. To do so may result in an explosion or fire.

WHAT TO DO IF YOU SMELL GAS:

- Do not try to light any appliance.
- Do not touch any electrical switch; do not use any phone in your building.
- Immediately call your gas supplier from a neighbor's phone. Follow the gas supplier's instructions.
- If you cannot reach your gas supplier, call the fire department.

Installation and service must be performed by a qualified installer, service agency or the gas supplier.

This manual should be maintained in legible condition and kept adjacent to the boiler or in a safe place for future reference.



Effective: 03-31-21
Replaces: 11-30-20
P/N 241664 Rev. 5

Revision 5 reflects the following changes:

Updated second footnote on Table D, value to CAN/CSA-B149.1 and added "+" footnote to Table D on page 10.

Updated "Vertical Venting (Category I, Fan Assisted)" section, adding new Note on page 31.

Updated " Horizontal Through-the-Wall Venting (Category III)" section, adding information on the third paragraph regarding the horizontal portions of the venting system on page 32. Also added information regarding the vent and intake pipe material certification standards on page 32.

Updated "Maintenance" section, 'Periodically' point number 3 was edited on page 55.

CONTENTS

1. WARNINGS	4	Venting	29
Pay Attention to these Terms	4	Changing the Flue Outlet	30
2. BEFORE INSTALLATION	5	Venting Installation Tips	31
Product Receipt.....	5	Venting Configurations	31
Model Identification	5	Sequence of Operation	36
Ratings and Certifications	5	Controls.....	40
Installations at Elevation	5	Wiring Diagram—Models 992C–1262C	49
Component Locations	6	Wiring Diagram—Models 1532C–2342C	50
General Information	7	5. START-UP	51
3. GENERAL SAFETY	8	Pre Start-up.....	51
Time/Temperature Relationships in Scalds.....	8	Start-Up.....	52
4. INSTALLATION	9	6. OPERATION	54
Installation Codes.....	9	Lighting Instructions	54
Equipment Base.....	9	To Turn Off Gas To Appliance	54
Stacking	9	7. MAINTENANCE	55
Clearances.....	11	Suggested Minimum Maintenance	
Combustion and Ventilation Air	12	Schedule.....	55
Conventional Combustion Air Supply.....	12	Preventive Maintenance Schedule.....	55
Water Piping.....	14	8. ILLUSTRATED PARTS LIST	57
Hydronic Heating.....	17	9. WARRANTY	64
Domestic Hot Water	21	Types H and WH	64
Pool Heating.....	22	Type P	65
Gas Supply.....	24	Start-up Check List.....	67
Electrical Power Connections	26	Important Instructions for the Commonwealth of	
Field Wiring Connection	27	Massachusetts.....	68

1. WARNINGS

Pay Attention to these Terms

▲ DANGER	Indicates the presence of immediate hazards which will cause severe personal injury, death or substantial property damage if ignored.
▲ WARNING	Indicates the presence of hazards or unsafe practices which could cause severe personal injury, death or substantial property damage if ignored.
▲ CAUTION	Indicates the presence of hazards or unsafe practices which could cause minor personal injury or product or property damage if ignored.
CAUTION	CAUTION used without the warning alert symbol indicates a potentially hazardous condition which could cause minor personal injury or product or property damage if ignored.
NOTE	Indicates special instructions on installation, operation, or maintenance which are important but not related to personal injury hazards.

▲ WARNING: Make sure the gas on which the heater will operate is the same type as that specified on the heater rating plate.

▲ WARNING: Should overheating occur or the gas supply valve fail to shut, do not turn off or disconnect the electrical supply to the heater. Instead, shut off the gas supply at a location external to the heater.

▲ WARNING: To minimize the possibility of improper operation, serious personal injury, fire, or damage to the boiler:

- Always keep the area around the boiler free of combustible materials, gasoline, and other flammable liquids and vapors.
- Boiler should never be covered or have any blockage to the flow of fresh air to the boiler.

▲ WARNING: Do not use this heater if any part has been under water. Immediately call a qualified service technician to inspect the heater and to replace any part of the control system and any gas control which has been under water.

▲ WARNING: All venting types must be of the same material or product throughout the entire exhaust installation to ensure proper securing and sealing.

▲ WARNING: Altering any Raypak pressure vessel by installing replacement heat exchangers, tube bundle headers, or any ASME parts not manufactured and/or approved by Raypak will instantly void the ASME and CSA ratings of the vessel and any Raypak warranty on the vessel. Altering the ASME or CSA ratings of the vessel also violates national, state, and local approval codes.

▲ WARNING: Both natural gas and propane have an odorant added to aid in detecting a gas leak. Some people may not physically be able to smell or recognize this odorant. If you are unsure or unfamiliar with the smell of natural gas or propane, ask your local gas supplier. Other conditions, such as “odorant fade,” which causes the odorant to diminish in intensity, can also hide, camouflage, or otherwise make detecting a gas leak by smell more difficult.

▲ WARNING: UL-recognized fuel gas detectors are recommended in all enclosed propane and natural gas applications wherein there is a potential for an explosive mixture of fuel gas to accumulate and their installation should be in accordance with the detector manufacturer’s recommendations and/or local laws, rules, regulations, or customs.

▲ WARNING: Risk of electrical shock. More than one disconnect switch may be required to de-energize the equipment before servicing.

▲ CAUTION: Operation of this heater in low-temperature systems requires special piping. Harmful internal condensation will occur if the inlet water temperature does not exceed 105°F. Warranty claims will be denied when condensation occurs.

▲ CAUTION: If this heater is to be installed above radiation level, it must be provided with a low water cut-off device at the time of heater installation.

▲ CAUTION: If this heater is to be installed in a negative- or positive-pressure equipment room, there are special installation requirements. Consult factory for details.

2. BEFORE INSTALLATION

Raypak strongly recommends that this manual be reviewed thoroughly before installing your Hi Delta® heater. Please review the General Safety information before installing the heater. Factory warranty does not apply to heaters that have been improperly installed or operated. (Refer to the warranty at the back of this manual.) Installation and service must be performed by a qualified installer, service agency or gas supplier. If, after reviewing this manual, you still have questions which this manual does not answer, please contact the manufacturer or your local Raypak representative.

Thank you for purchasing a Raypak product. We hope you will be satisfied with the high quality and durability of our equipment.

Product Receipt

On receipt of your heater it is suggested that you visually check for external damage to the shipping crate. If the crate is damaged, make a note to that effect on the Bill of Lading when signing for the shipment. Remove the heater from the shipping packaging. Report any damage to the carrier immediately.

On occasion, items are shipped loose. Be sure that you receive the correct number of packages as indicated on the Bill of Lading.

Claims for shortages and damages must be filed with the carrier by consignee. Permission to return goods must be received from the factory prior to shipping. Goods returned to the factory without an authorized Returned Goods Receipt number will not be accepted. All returned goods are subject to a restocking charge.

When ordering parts, you must specify the model and serial number of the heater. When ordering under warranty conditions, you must also specify the date of installation.

Purchased parts are subject to replacement only under the manufacturer's warranty. Debits for defective replacement parts will not be accepted and will be replaced in kind only per Raypak's standard warranties.

Model Identification

The model identification number and heater serial number are found on the heater rating plate located on the lower right outside jacket of the heater. The model number will have the form H3-992C or similar depending on the heater size and configuration. The letter(s) in the first group of characters identifies the application (H = Hydronic Heating, WH = Domestic Hot Water, P = Pool). The number which follows identifies the firing mode (3 = 2-stage). The second group of characters identifies the size of the heater (four numbers representing the approximate MBTUH input), and, where applicable, a letter indicating the manufacturing series.

Ratings and Certifications

Standards:

- ANSI Z21.13 · CSA 4.9 - latest edition, Gas-Fired Hot Water Boilers
- ANSI Z21.56 · CSA 4.7 - latest edition Gas-Fired Pool Heaters
- ANSI Z21.10.3 · CSA 4.3 - latest edition Gas Water Heaters
- Low-lead compliant (<0.25%) CSA-certified.

All Raypak heaters are National Board registered, and design-certified and tested by the Canadian Standards Association (CSA) for the U.S. and Canada. Each heater is constructed in accordance with Section IV of the American Society of Mechanical Engineers (ASME) Heater Pressure Vessel Code and bears the ASME stamp. The heater also complies with the latest edition of ASHRAE 90.1 Standard.

⚠ WARNING: Altering any Raypak pressure vessel by installing replacement heat exchangers, tube bundle headers, or any ASME parts not manufactured and/or approved by Raypak will instantly void the ASME and CSA ratings of the vessel and any Raypak warranty on the vessel. Altering the ASME or CSA ratings of the vessel also violates national, state, and local approval codes.

Installations at Elevation

Rated inputs are suitable for up to 4,500 ft (1372 m) (elevation without de-rating. Consult the factory for installations at altitudes over 4,500 ft (1372 m) above sea level. Orifices are not affected.

Component Locations

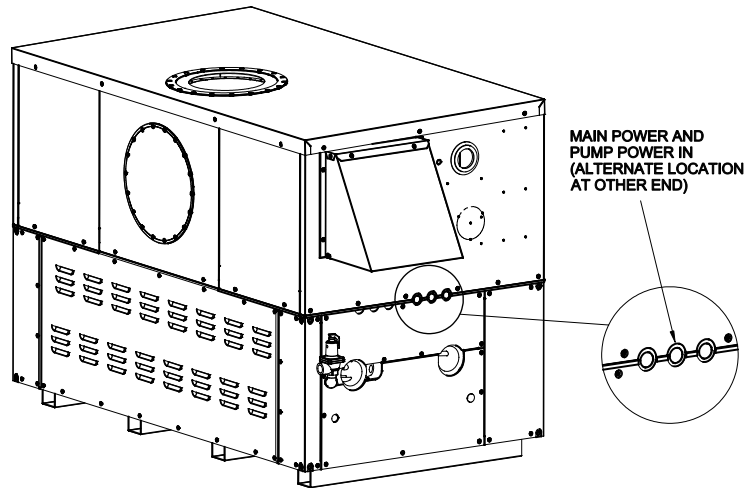

Figure 1. Component Locations – Back

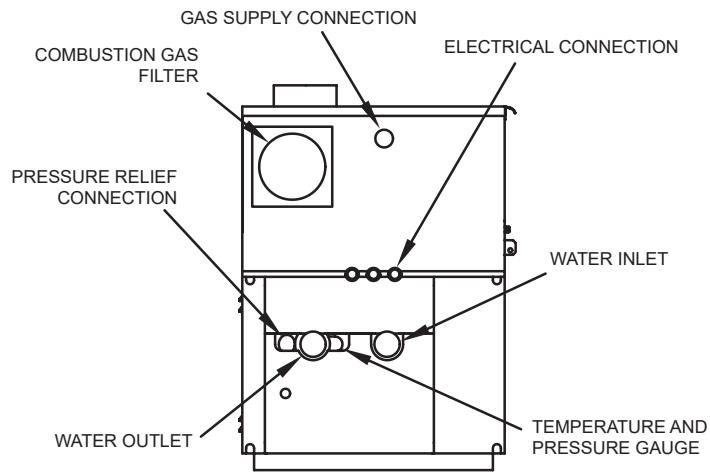
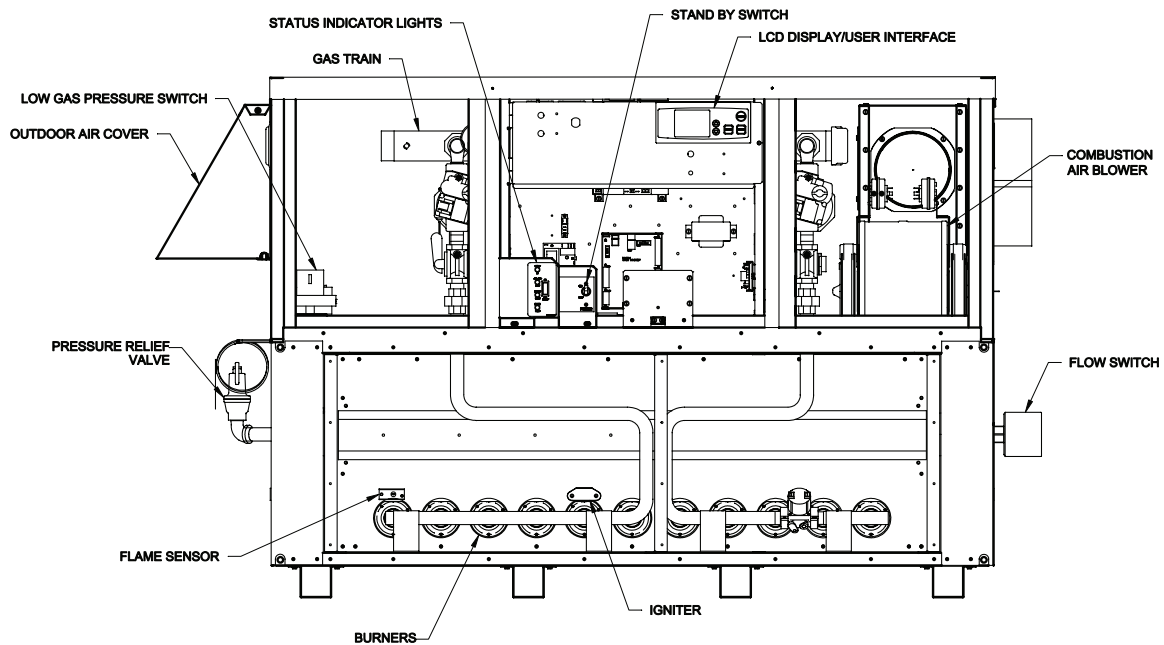

Figure 2. Component Locations – Left Side



Panels removed for clarity.

Figure 3. Component Locations – Front

General Information

Model No.	Quantity of			Vent Size (in.)	
	Burners	Gas Valves	Blowers	Flue	Intake
992C	11	2 + 1*	2	10	10
1262C	14	3 + 1*	2	12	10
1532C	17	4	2	12	10
1802C	20	4	2	14	10
2002C	23	5	3	14	10
2072C	23	5	3	14	10
2342C	26	5	3	16	10

*Hidden solenoid valve located inside of air plenum.

Table A. Basic Data

Model No.	Burners per Valve					Stages				% Fire at Stages			
	1	1A	2	3	4	1	2	3	4	1	2	3	4
992C	6		3	2		1	1, 2	1, 2, 3		54	82	100	
1262C	5		3	3	3	1	1, 2	1, 2, 3	1, 2, 3, 4	36	57	79	100
1532C	6		4	4	3	1	1, 2	1, 2, 3	1, 2, 3, 4	35	59	82	100
1802C	6		4	5	5	1	1, 2	1, 2, 3	1, 2, 3, 4	30	50	75	100
2002C	4	5	5	5	4	1, 1A	1, 1A, 2	1, 1A, 2, 3	1, 1A, 2, 3, 4	39	61	83	100
2072C	4	5	5	5	4	1, 1A	1, 1A, 2	1, 1A, 2, 3	1, 1A, 2, 3, 4	39	61	83	100
2342C	5	6	5	5	5	1, 1A	1, 1A, 2	1, 1A, 2, 3	1, 1A, 2, 3, 4	42	62	81	100

Table B. Manifold Data

The VERSA displays how many stages are active out of the total available for the system. On multiple-unit installations, this may indicate more stages in operation than a single unit has available.

3. GENERAL SAFETY

To meet commercial hot water use needs, the high limit safety control on this water heater is adjustable up to 210°F (99°C). However, water temperatures over 125°F (52°C) can cause instant severe burns or death from scalds. When supplying general purpose hot water, the recommended initial setting for the temperature control is 125°F (52°C).

Safety and energy conservation are factors to be considered when setting the water temperature on the thermostat. The most energy-efficient operation will result when the temperature setting is the lowest that satisfies the needs of the application.

Water temperature over 125°F (52°C) can cause instant severe burns or death from scalds. Children, disabled and elderly are at highest risk of being scalded.

- Feel water before bathing or showering.
- Temperature limiting valves are available.

NOTE: When this water heater is supplying general purpose hot water for use by individuals, a thermostatically controlled mixing valve for reducing point of use water temperature is recommended to reduce the risk of scald injury. Contact a licensed plumber or the local plumbing authority for further information.

Maximum water temperatures occur just after the heater's burner has shut off. To determine the water temperature being delivered, turn on a hot water faucet and place a thermometer in the hot water stream and read the thermometer.

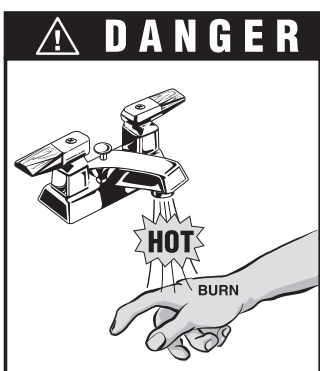

Water temperature over 125°F can cause instant severe burns or death from scalds.

Children, disabled, and elderly are at highest risk of being scalded.

See instruction manual before setting temperature at water heater.

Feel water before bathing or showering.

Temperature limiting valves are available, see manual.

Time/Temperature Relationships in Scalds

The following chart details the relationship of water temperature and time with regard to scald injury and may be used as a guide in determining the safest water temperature for your applications.

Water Temp.	Time To Produce Serious Burn
120°F (49°C)	More than 5 minutes
125°F (52°C)	1-1/2 to 2 minutes
130°F (54°C)	About 30 seconds
135°F (57°C)	About 10 seconds
140°F (60°C)	Less than 5 seconds
145°F (63°C)	Less than 3 seconds
150°F (66°C)	About 1-1/2 seconds
155°F (68°C)	About 1 seconds

Table courtesy of the Shriners Burn Institute

Table C. Time to Produce Serious Burn

The temperature of the water in the heater can be regulated by adjusting the set-point, this process is fully described in the manual in "Controls" on page 40.

For accurate control of water temperature, the sensors must be properly installed according with the piping configuration, see "Applications & Modes" on page 19.

CAUTION: Hotter water increases the risk of scalding! There is a hot water scald potential if the thermostat is set too high.

Temperature & Pressure Gauge

The temperature and pressure gauge is factory-mounted in the in/out header.

4. INSTALLATION

Installation Codes

Installations must follow these codes:

- Local, state, provincial, and national codes, laws, regulations and ordinances
- National Fuel Gas Code, ANSI Z223.1/NFPA 54 – latest edition (NFGC)
- National Electrical Code, ANSI/NFPA 70 - latest edition (NEC)
- Standard for Controls and Safety Devices for Automatically Fired Boilers, ANSI/ASME CSD-1, when required (CSD-1)
- For Canada only: CAN/CSA B149 Installation Code (B149) and CSA C22.1 C.E.C. Part 1 (C22.1)

Equipment Base

The heater should be mounted on a level, structurally sound surface. The heater is approved for installation on a combustible surface but must NEVER be installed on carpeting. Gas-fueled equipment installed in enclosed parking garages must be located at least 18 in. above the floor.

Stacking

Hi Delta units can be stacked two units high with an optional stacking rack. A stacking kit (sales order option X-1) is available from Raypak for this type of installation. For installations above grade, a reinforcing kit (sales order option X-2) may also be required.

CAUTION: The heaters should be located in an area where water leakage will not result in damage to the area adjacent to the appliances or to the structure. When such locations cannot be avoided, it is recommended that a suitable catch pan, adequately drained, be installed under the appliance. The pan must not restrict air flow.

In addition, the heater shall be installed such that the gas ignition system components are protected from water (dripping, spraying, rain, etc.) during appliance operation or service (circulator replacement, control replacement, etc.).

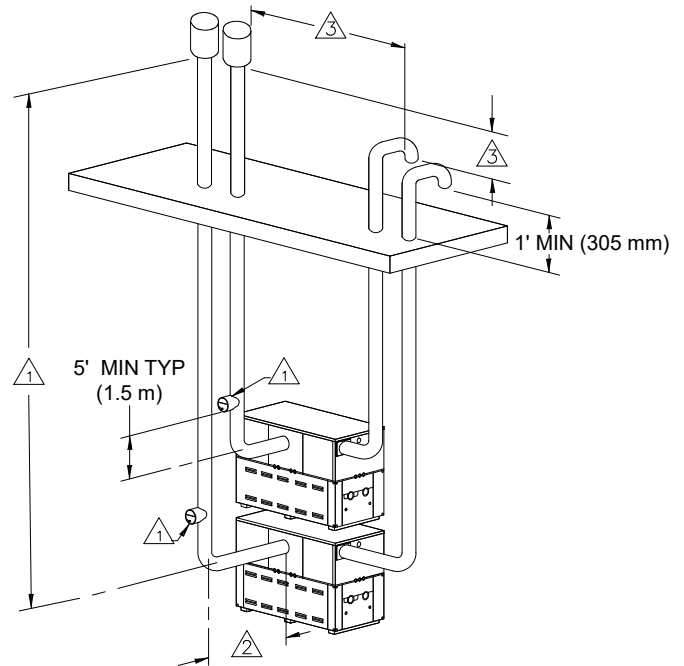

NOTE:

- △ FOR CAT I VENT HEIGHT UP TO 25 FT (7.6 m), NO DRAFT RELIEF REQUIRED. FOR CAT I VENT HEIGHT 25-50 FT (7.6-15.2 m), USE A SINGLE-ACTION BAROMETRIC DAMPER AS SHOWN. FOR CAT I VENT HEIGHT OVER 50 FT (15.2 m) USE A BALANCING BAFFLE IMMEDIATELY ABOVE THE DAMPER.
- △ PER NATIONAL FUEL GAS CODE (NFGC).
- △ REQUIRED SEPARATION IS 3 FT (942 cm) VERTICAL OR 3 FT (942 cm) HORIZONTAL.

Figure 4. Typical Stacked Installation

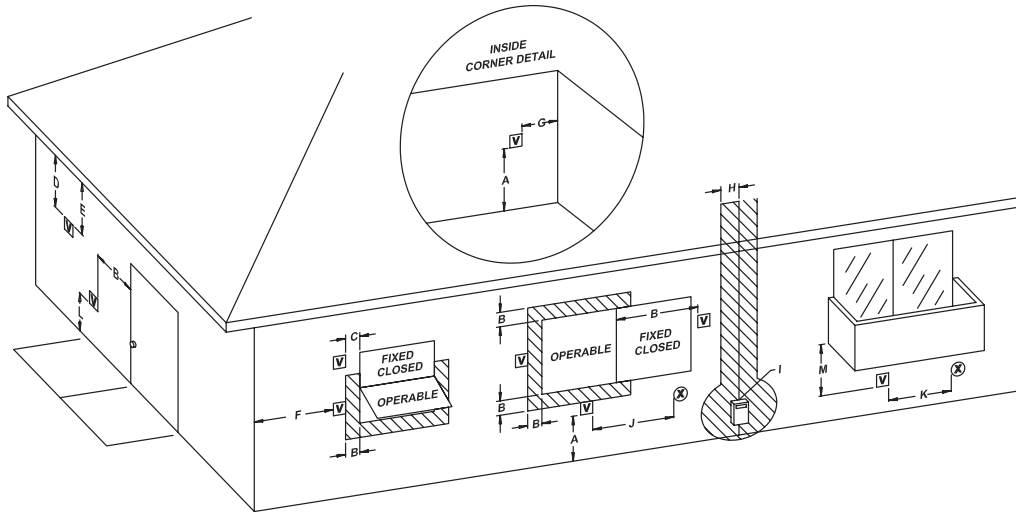

Figure 5. Minimum Clearances from Vent/Air Inlet Terminations – Indoor and Outdoor Installations

		U.S. Installations ¹	Canadian Installations ²
A	Clearance above grade, veranda, porch, deck, or balcony	1 ft (30 cm)	1 ft (30 cm)
B	Clearance to window or door that may be opened	4 ft (1.2m) below or to side of opening; 1 foot (30 cm) above opening	3 ft (91 cm)
C	Clearance to permanently closed window	*	*
D	Vertical clearance to ventilated soffit located above the terminal within a horizontal distance of 2 ft (61cm) from the centerline of the terminal	5 ft (1.5m)	*
E	Clearance to unventilated soffit	*	*
F	Clearance to outside corner	*	*
G	Clearance to inside corner	6 ft (1.83m)	*
H	Clearance to each side of center line extended above meter/regulator assembly	*	3 ft (91 cm) within a height 15 ft above the meter/regulator assembly
I	Clearance to service regulator vent outlet	*	6 ft (1.83m)
J	Clearance to non-mechanical air supply inlet to building or the combustion air inlet to any other appliance	4 ft (1.2m) below or to side of opening; 1 ft (30 cm) above opening	3 ft (91 cm)
K	Clearance to mechanical air supply inlet	3 ft (91 cm) above if within 10 ft (3m) horizontally	6 ft (1.83m)
L	Do not terminate above paved sidewalk or paved driveway	+	Slip hazard due to frozen condensate
M	Clearance under veranda, porch, deck or balcony	*	12 in. (30 cm) ⁴

¹ In accordance with the current ANSI Z223.1/NFPA 54 National Fuel Gas Code

² In accordance with the current CAN/CSA-B149.1 Installation Codes

³ Vent terminal shall not terminate directly above sidewalk or paved driveway located between 2 single family dwellings that serves both dwellings

⁴ Permitted only if veranda, porch, deck, or balcony is fully open on a minimum of two sides beneath the floor and top of terminal and underside of veranda, porch, deck or balcony is greater than 1 ft (30cm)

* Clearances in accordance with local installation codes and the requirements of the gas supplier

+ 7' (2.13 m) for mechanical draft systems (Category I appliances).

Table D. Vent/Air Inlet Termination Clearances

Clearances

Indoor Installations

When installed according to the listed minimum clearances from combustible construction, these heaters can still be serviced without removing permanent structural construction around the heater. Combustible clearances can be reduced per the NFGC; see paragraph 10.2.3. However, for ease of servicing, we recommend a clearance of at least 24 in. in front, and at least 12 in. on the water connection side. This will allow the heater to be serviced in its installed location without movement or removal of the heater.

Service clearances less than the minimums may require removal of the heater to service either the heat exchanger or the burner tray. In either case, the heater must be installed in a manner that will enable the heater to be serviced without removing any structure around the heater.

Heater Side	Minimum Clearances from Combustible Surfaces in. (mm)	Minimum Service Clearance in. (mm)
Floor *	0	0
Rear	1 (25)	6 (146)
Water Side	12 (305)	24 (610)
Other Side	1 (25)	24 (610)
Top	1 (25)	6 (146)
Front	Open	24 (610)
Vent	2 (51)	2 (51)

* DO NOT install on carpeting

Table E. Clearances – Indoor Installations

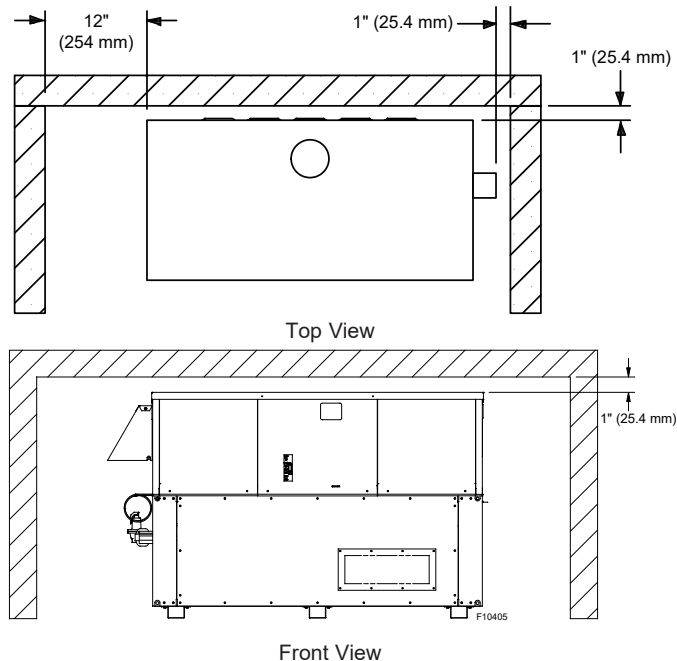

Figure 6. Minimum Clearances from Combustible Surfaces – Indoor Installations

Outdoor Installations

These heaters are design-certified for outdoor installation. Heaters must not be installed under an overhang that is less than 3 ft (91 cm) from the top of the heater. Three sides must be open in the area under the overhang. Roof water drainage must be diverted away from heaters installed under overhangs.

These clearances are required when the outdoor vent cap is used. If installing the heater outdoors with a vent stack, the indoor clearances may be utilized.

The combustion air intake hood **MUST** be used for outdoor installations. The hood is shipped loose and installed on the side of the heater over the filter box at the jobsite.

Heater Side	Minimum Clearances from Combustible Surfaces in. (mm)	Minimum Service Clearance in. (mm)
Rear	OPEN	24 (610)
Front	12 (305)	6 (152)
Water Side	36 (914)	36 (914)
Other Side	36 (914)	36 (914)
Top	Unobstructed	36 (914)
Vent	N/A	N/A

Table F. Clearances – Outdoor Installations

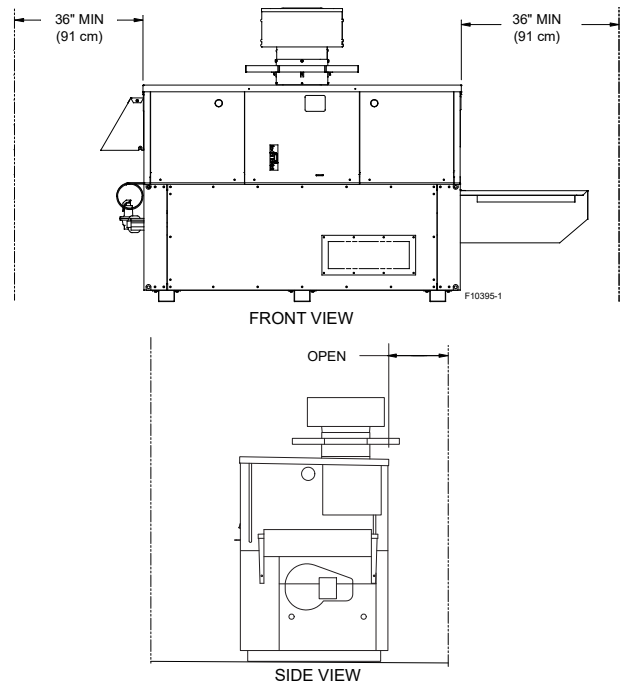

Figure 7. Minimum Clearances from Combustible Surfaces – Outdoor Installations

Combustion and Ventilation Air

NOTE: Use of the heater in construction areas where fine particulate matter, such as concrete or dry-wall dust, is present may result in damage to the heater that is not covered by the warranty. If operated in a construction environment, a clean source of combustion air must be provided directly to the heater.

Inside Air Contamination

All heaters experience some condensation during start-up. The condensate from flue gas is acidic. Combustion air can be contaminated by certain vapors in the air which raise the acidity of the condensate. Higher acidity levels attack many materials including stainless steel, which is commonly used in high efficiency systems.

The heater can be supplied with corrosion-resistant, non-metallic intake air vent material. Choose to use outside combustion air for one or more of the following reasons:

1. Installation is in an area containing contaminants listed below which will induce acidic condensation.
2. Reduce infiltration into your building through openings around windows and doors.
3. Use AL29-4C stainless steel vent pipe, which is more corrosion-resistant than standard metallic vent pipe. In extremely contaminated areas, this may also experience deterioration.

Products causing contaminated combustion air:

- spray cans containing chloro/fluorocarbons
- permanent wave solutions
- chlorinated waxes/cleaners
- chlorine-based swimming pool chemicals
- calcium chloride used for thawing
- sodium chloride used for water softening
- refrigerant leaks
- paint or varnish removers
- hydrochloric acid/muriatic acid
- cements and glues
- antistatic fabric softeners used in clothes dryers
- chloride-type bleaches, detergents, and cleaning solvents found in household laundry rooms
- adhesives used to fasten building products
- similar products

Areas where contaminated combustion air commonly exists:

- dry cleaning/laundry areas
- metal fabrication plants
- beauty shops

- refrigeration repair shops
- photo processing plants
- auto body shops
- plastic manufacturing plants
- furniture refinishing areas and establishments
- new building construction
- remodeling areas
- open pit skimmers

Check for areas and products listed above before installing heater. If found:

- remove products permanently, OR
- install TruSeal direct vent.

Indoor Units

The heater must be supplied with sufficient quantities of non-contaminated air to support proper combustion and equipment ventilation. Combustion air can be supplied via conventional means where combustion air is drawn from the area immediately surrounding the heater, or via direct vent, where combustion air is drawn directly from outside. All installations must comply with the requirements of the NFGC (U.S.) and B149 (Canada), and all local codes.

CAUTION: Combustion air must not be contaminated by corrosive chemical fumes which can damage the heater; such damage will not be covered under warranty. (See "Inside Air Contamination".)

NOTE: It is recommended that the intake vent be insulated to minimize sweating.

Reversing Air Filter

Follow these instructions to change the air duct connection from the left-hand side (standard) to the right-hand side:

1. Remove the four screws and the dust cover from the right-hand side of the heater.
2. Remove the four screws and the air filter bracket from the left-hand side of the heater.
3. Reverse the components and reattach in the new location, making sure that the air filter locking bracket is on the bottom. (The air filter locking bracket is reversible.)

Conventional Combustion Air Supply

U.S. Installations

All Air from Inside the Building

The confined space shall be provided with TWO permanent openings communicating directly with an additional room(s) of sufficient volume so that the combined volume of all spaces meets the criteria for a room large in comparison

(NFGC). The total input of all gas utilization equipment installed in the combined space shall be considered in making this determination. Each opening shall have a minimum free area of 1 in.² per 1,000 BTUH (2,225 mm² per kW) of the total input rating of all gas utilization equipment in the confined space, but not less than 100 in.² (645 cm²). One opening shall commence within 12 in. (305 mm) of the top, and one opening shall commence within 12 in. (305 mm) of the bottom of the enclosure. The minimum dimension of air openings shall be not less than 3 in. (76 mm) in any direction.

All Air from Outdoors

The confined space shall communicate with the outdoors in accordance with one of the methods below. The minimum dimension of air openings shall not be less than 3 in. (76 mm) in any direction. Where ducts are used, they shall be of the same cross-sectional area as the net free area of the openings to which they connect.

1. Two permanent openings, one commencing within 12 in. (305 mm) of the top, and one commencing within 12 in. (305 mm) of the bottom of the enclosure, shall be provided. The openings shall communicate directly, or by ducts, with the outdoors or spaces (crawl or attic) that freely communicate with the outdoors.
 - a. Where directly communicating with the outdoors or where communicating to the outdoors through vertical ducts, each opening shall have a minimum free area of 1 in.² per 4,000 BTUH (550 mm² per kW) of total input rating of all equipment in the enclosure.
 - b. Where communicating with the outdoors through horizontal ducts, each opening shall have a minimum free area of 1 in.² per 2,000 BTUH (1,100 mm² per kW) of total input rating of all equipment in the enclosure.
2. One permanent opening, commencing within 12 in. (305 mm) of the top of the enclosure, shall be permitted where the equipment has clearances of at least 1 in. (25 mm) from the sides and back and 6 in. (152 mm) from the front of the appliance. The opening shall directly communicate with the outdoors or shall communicate through a vertical or horizontal duct to the outdoors or spaces that freely communicate with the outdoors, and shall have a minimum free area of:
 - a. 1 in.² per 3,000 BTUH (740 mm² per kW) of the total input rating of all equipment located in the enclosure, and
 - b. Not less than the sum of the areas of all vent connectors in the confined space.

⚠ WARNING: Do not use one permanent opening method if the equipment room is under negative pressure conditions or the equipment is common vented with other gas-fired appliances.

Canadian Installations

CAUTION: All combustion air must be drawn from the air outside of the building; the mechanical equipment room must communicate directly with the outdoors.

1. Ventilation of the space occupied by the heater shall be provided by an opening(s) for ventilation air at the highest practical point communicating with the outdoors. The total cross-sectional area of such an opening(s) shall be at least 10% of the area required in 2. and 3. (below), but in no case shall the cross-sectional area be less than 10 in.² (65 cm²).
2. For heaters using a barometric damper in the vent system there shall be a permanent air supply opening(s) having a cross section area of not less than 1 in.² per 7,000 BTUH (320 mm² per kW) up to and including 1 million BTUH, plus 1 in.² per 14,000 BTUH (160 mm² per kW) in excess of 1 million BTUH. This opening(s) shall be either located at or ducted to a point not more than 18 in. (450 mm) nor less than 6 in. (152 mm) above the floor level. The duct can also “goose neck” through the roof. The duct is preferred to be straight down and terminated 18 in. (450 mm) from the floor, but not near piping. This air supply opening requirement shall be in addition to the air opening for ventilation air required in 1. (above).

⚠ WARNING: Care must be taken to ensure that the equipment room is not under negative pressure conditions or that the equipment is not common-vented with other gas-fired appliances.

3. For heaters not using a barometric damper in the vent system, and when air supply is provided by natural air flow from outdoors for a power burner and there is no draft regulator, drafhood or similar flue gas dilution device installed in the same space, in addition to the opening for ventilation air required in step 1. There shall be a permanent air supply opening(s) having a total cross-sectional area of not less than 1 in.² for each 30,000 BTUH mm² per kW) of total rated input of the burner(s), and the location of the opening(s) shall not interfere with the intended purpose of the opening(s) for ventilation air referred to in (1). This opening(s) can be ducted to a point not more than 18 in. (450 mm) nor less than 6 in. (152 mm) above the floor level. The duct can also “goose neck” through the roof. The duct is preferred to be straight down 18 in. (450 mm) from the floor, but not near piping.
4. Refer to B149 Installation code for additional information.

Ducted Combustion Air

In certain applications it may be desirable to duct the combustion air directly to the heater. This should be done with PVC, CPVC or single-wall galvanized ducting. The duct will attach directly to the collar on the air filter housing

located on the side of the heater. The ducting is attached to the air filter housing collar using three or four sheet metal screws (not supplied) equally distributed around the circumference of the duct. All ducting should be self-supported. The filter housing is not designed to support the air duct.

Room Ventilation Using Direct Venting

If outside air is drawn through the intake pipe directly to the unit for combustion:

1. Install combustion air direct vent in accordance with Figure 38 on page 34 (horizontal) or Figure 40 on page 35 (vertical) of this manual.
2. Ventilation of the space occupied by the heater(s) is recommended and can be provided by an opening(s) for ventilation air at within 12" (305 mm) of the ceiling or the highest practical point communicating with the outdoors. The total cross-sectional area should be at least 1 in.² of free area per 20,000 BTUH (111 mm² per kW) of total input rating of all equipment in the room when the opening is communicating directly with the outdoors or through vertical duct(s). The total cross-sectional area should be at least 1 in.² of free area per 10,000 BTUH (222 mm² per kW) of total input rating of all equipment in the room when the opening is communicating with the outdoors through horizontal duct(s). Damage to the equipment due to inadequate ventilation of the space is not a warrantable failure.

NOTE: In cold climates, and to mitigate potential freeze-up, Raypak highly recommends the installation of a motorized sealed damper to prevent the circulation of cold air through the heater during the non-operating hours.

Direct-Vent Combustion Air Using TruSeal®

In certain applications it may be necessary to isolate the unit from ambient air, to meet direct-vent requirements. For example, if damaging contaminants may be present in the mechanical room, allowing them to enter the combustion system may be a safety hazard. Simply installing combustion air ducting is not sufficient, as internal connections must also be sealed. Raypak's TruSeal option (sales option D-21 if factory-installed or D-22 if field-installed) provides the sealed internal ducting from combustion air intake port to the blower(s).

Combustion air may be ducted directly to the heater by using PVC, CPVC or sealed single-wall galvanized ducting. The combustion air duct must be a sealed-joint design, to prevent ambient air from entering the ducting. B-vent does not meet this requirement. The duct will attach directly to the air collar located on the side of the heater, using three or four sheet metal screws (not supplied) equally positioned around the circumference of the duct. The screws and duct connection point must be sealed with RTV (not supplied). An inline intake air filter kit (sales order option D-17) must be installed in the combustion air duct.

CAUTION: Use TruSeal combustion air if damaging airborne contaminants are or will be present in the heater area. (See "Inside Air Contamination".)

TruSeal heater connection points are available as follows:

992C to 1802C	Left side – standard
	Right side – optional
2002C to 2342C	Right side only

Water Piping

General

The heater should be located so that any water leaks will not cause damage to the adjacent area or structures.

CAUTION: This heater requires forced water circulation when the burner is operating. See Table G and Table H for minimum and maximum flow rates and water pump selection. The pump must be interlocked with the heater to prevent heater operation without water circulation.

NOTE: Minimum pipe size for in/out connections is 2 NPT. Verify proper flow rates and ΔT as instructed in this manual.

Reversing Water Connections

Follow these instructions to change the water connections from the left-hand side (standard) to the right-hand side.

1. Disconnect all electrical power from the heater (if applicable).
2. Label all electrical connections and conduit lines. This may include the flow switch, low water cut-off probe and/or pump.
3. Disconnect or isolate the main gas pipe from the heater (if applicable).
4. Remove both in/out and return header access panels by removing all sheet metal screws.
5. Remove all plumbing fittings to the header. This will include both inlet and outlet water pipe unions and the pressure relief valve and drain piping.
6. Remove limits, control bulbs and/or thermocouples.
7. Remove the eight flange nuts and the in/out header from the left-hand side.
8. Remove the eight flange nuts and the return header from the right-hand side.
9. Remove the header stud bolts from each tube sheet.
10. Reverse the headers to the new location.
11. Install NEW red beveled O-rings flush against both tube sheets with the bevel facing outward.
12. Push the header firmly against the O-rings. Install and tighten the flange nuts onto the stud bolts until finger tight.
13. Slowly tighten the flange nuts, starting from the center

nut (number 1) in **Figure 8** and working sequentially around the header as indicated. Torque all nuts to 25 ft/lb. **DO NOT OVER-TIGHTEN.**

14. Re-route the capillary bulbs and traces, wiring etc. to the new location, adding thermal paste and shim to the capillary well.
15. Move the access panels to the opposite ends of the unit, to fit around the pipe connections.

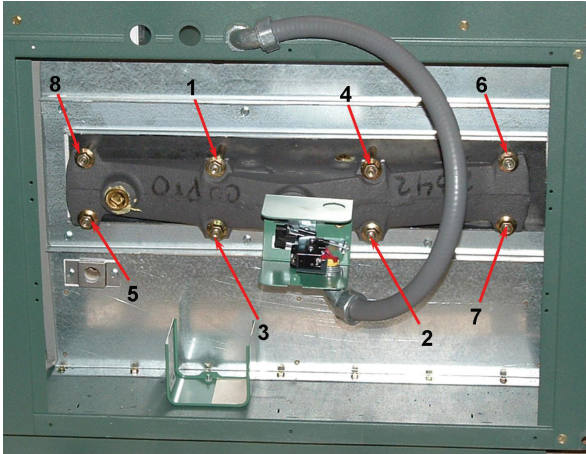

Figure 8. Torque Sequence

Relief Valve Piping

▲ WARNING: Pressure relief valve discharge piping must be piped near the floor and close to a drain to eliminate the potential of severe burns. Do not pipe to any area where freezing could occur. Refer to local codes.

Hydrostatic Test

Unlike many types of heaters, this heater does not require hydrostatic testing prior to being placed in operation. The heat exchanger has already been factory-tested and is rated for 160 psi operating pressure. However, Raypak does recommend hydrostatic testing of the piping connections to the heater and the rest of the system prior to operation. This is particularly true for hydronic systems using expensive glycol-based anti-freeze. Raypak recommends conducting the hydrostatic test before connecting gas piping or electrical supply.

Leaks must be repaired at once to prevent damage to the heater. **NEVER** use petroleum-based stop-leak compounds.

To perform hydrostatic test:

1. Connect fill water supply. With bleed valve open, fill heater with water. When water flows from bleed valve, shut off water. Close bleed valve. Carefully fill the rest of the system, making sure to eliminate any entrapped air by using high-point vents. Close feed valve. Test at standard operating pressure for at least 24 hours.

2. Make sure constant gauge pressure has been maintained throughout test.
3. Check for leaks. Repair if found.

Cold Water Protection (CWP)

This heater must operate with a stable inlet temperature of 105°F (41°C), long periods of operation with temperatures below 105°F (41°C) can excessively cool the products of combustion, resulting in collection of condensate in the heat exchanger, damaging the heat exchanger, combustion chamber, significantly reducing the life of the equipment. The following applications are approved configurations supported by Raypak for CWP systems.

A bypass allows part of the heater discharge water to be mixed with the cooler water returning to the heater inlet, to increase the heater inlet temperature above 105°F (41°C). This precautionary measure should prevent the products of combustion from condensing in most installations.

CAUTION: Damage due to internal condensation may occur if the heater inlet water temperature does not exceed 105°F (41°C) within 7 minutes of start-up. Warranty claims will be denied for damage or failures caused by condensation.

H models: MIX TYPE = VALVE

Heating Systems, where the inlet water temperature remains below 105°F (41°C) must have cold water protection. Known protection methods consist of mixing heated outlet water with the inlet water using a bypass to raise the inlet to 105°F (41°C) or higher. Once the system is heated up and has return water temperatures of 105°F (41°C) or higher, the mixing of outlet water with inlet water is no longer needed and the bypass can be shut off. If the bypass is not shut off as the system heats up, the outlet temperature may continue to climb and trip the high limit, thereby shutting down the heater. Thus an automatic valve system, such as a three-way proportional valve to control the bypass, should be used. The integrated VERSA IC® control system provides automatic functionality to control a proportional 3-way valve to provide Cold Water Protection for Single or Cascade configurations. See **Figure 9**.

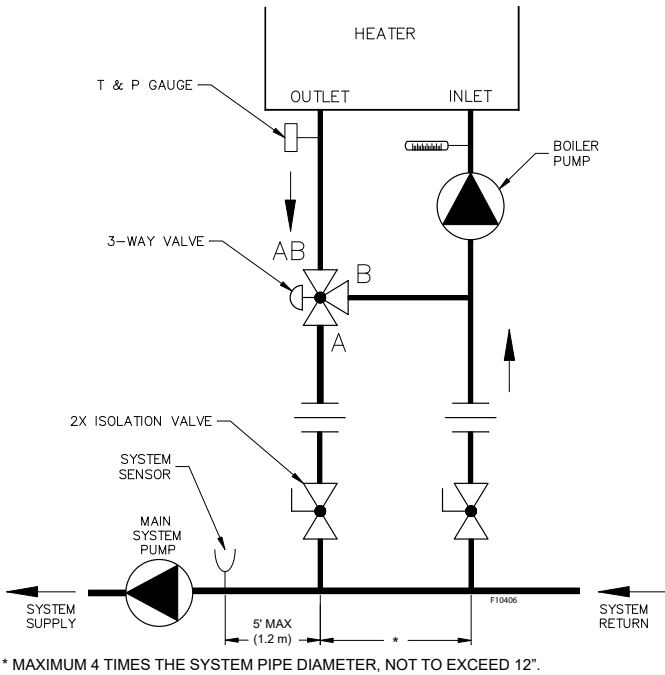

Figure 9. CWP-Hydraulic Single-Boiler (BOIL 3-way) Mode 1

H models: MIX TYPE = PUMP

H models include a second option for individual Cold Water Protection method (“PUMP”). MIX TYPE = PUMP uses a Variable-Speed Pump as a CWP mechanism recommended for those systems that require low-lead/non-ferrous plumbing. Applications that require a working setpoint over 160°F (71°C) must use an H model with a storage tank. See Figure 10 through Figure 12.

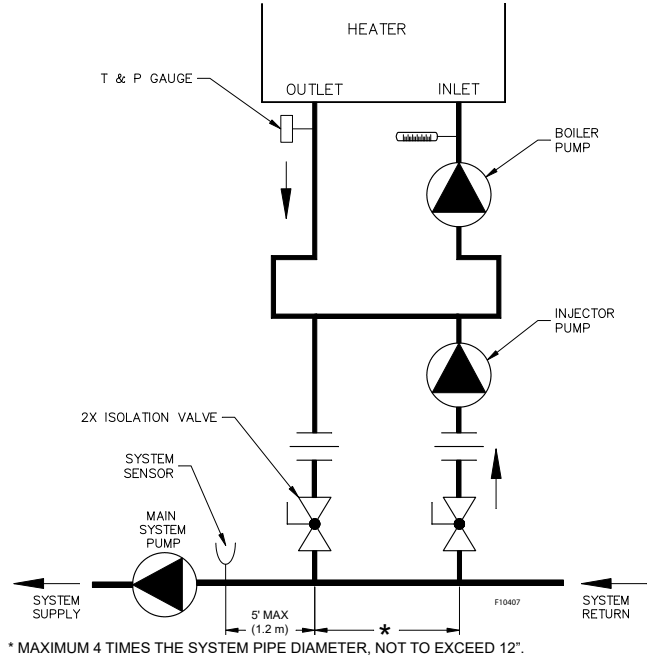

Figure 10. H - Hydraulic - Single Boiler with CWP (VS Pump - MIX TYPE = 2)

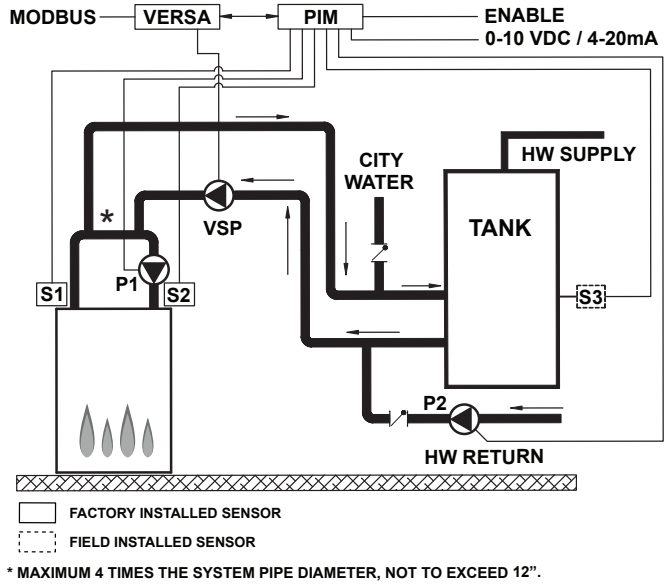

Figure 11. Low-Temp Process - Open Loop: H model, Single with Storage Tank

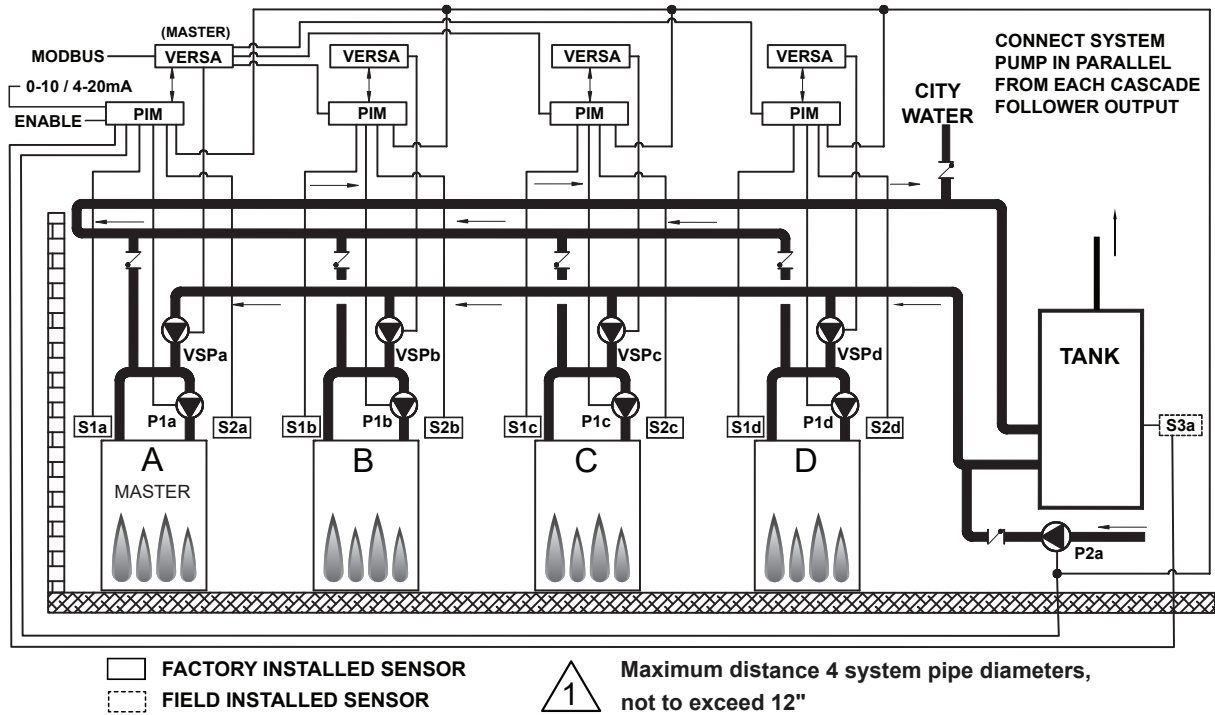

Figure 12. Low Temp Process - Open Loop: H model, Cascade with Storage Tank

Cold Water Protection: WH models

Direct DHW heating systems utilize a variable speed pump arrangement (MIX TYPE = PUMP) to keep the heater inlet at or above 105°F (41°C). The integrated VERSA IC® control system provides functionality to control a single variable speed injection pump via an added inverter drive to provide Cold Water Protection to the system.

See **Figure 13** as an example of a single heater application. For more information regarding this function see VERSA IC® manual (241493).

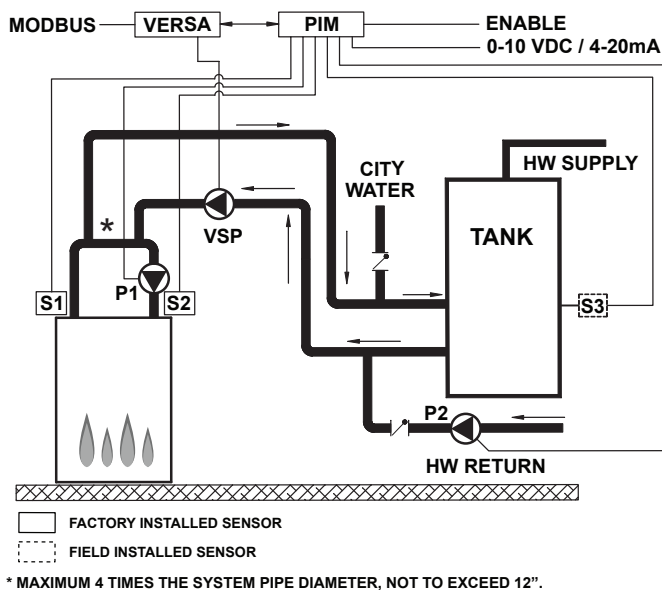

Figure 13. WH Direct DHW - Single Heater with CWP (VS Pump - MIX TYPE = 2)

Hydronic Heating

System Design

Hot water heating systems all have unique levels of operating diversity. Raypak equipment design utilizes as little water mass as possible to ensure maximum operating efficiency. Primary / Secondary piping arrangement is the method recommended and the only method supported by Raypak for installation of Hi Delta equipment. Proper system design should always include system flow in excess of the connected boiler flow for proper operation (Boiler Flow + 15% = Min. System Flow). When appropriate, a Buffer/De-coupler Tank can be used where system flow may be reduced below the connected boiler flow. Failure to design for adequate system flow (i.e. bypasses, 3-way control valves, flow limiting balance devices, buffer tanks, etc.) will result in boiler short-cycling and poor system performance. Always contact your local Raypak representative for system design assistance to avoid these issues.

Pump Selection

In order to ensure proper performance of your heater system, you must install a correctly-sized pump. Raypak recommends using a 20°F (11°C) ΔT as design ΔT . (ΔT is the temperature difference between the inlet and outlet water when the heater is firing at full rate). If a ΔT of larger than 20°F (11°C) is necessary, see **Table G** for flow rate requirements.

Feedwater Regulator

Raypak recommends that a feedwater regulator be installed and set at 12 psi minimum pressure at the highest point of the system. Install a check valve or back flow device upstream of the regulator, with a manual shutoff valve as required by local codes.

CAUTION: Be careful when installing the drywell not to over-tighten the well as this can damage the well and may prevent the sensor from fitting properly.

Piping

All high points should be vented. Purge valves and a bypass valve should be installed. A heater installed above radiation level must be provided with a low water cut-off device (sales order option F-10). The heater, when used in connection with a refrigeration system, must be installed so that the chilled medium is piped in parallel with the heater with appropriate valves to prevent the chilled medium from entering the heater.

The piping system of a hot water heater connected to heating coils located in air handling units where they may be exposed to circulating refrigerated air, must be equipped with flow control valves or other automatic means to prevent gravity circulation of the heater water during the cooling cycle. It is highly recommended that the piping be insulated.

Air-Separation/Expansion Tank

All heaters should be equipped with a properly-sized expansion tank and air separator fitting as shown in **Figure 14**.

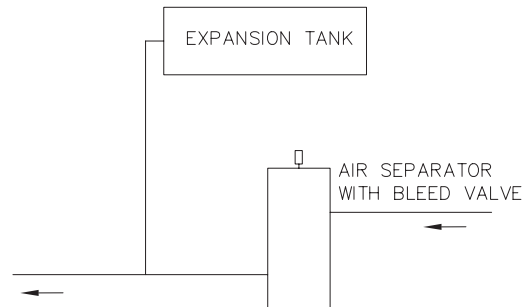

Figure 14. Air-Separation/Expansion Tank

System Sensor Installation

The System Sensor (S3) is required for all selectable mode unless the unit's firing rate will be controlled by an external source such as the Temp Tracker MOD+ Hybrid sequencer (sales option B-36). Proper placement and method of installation are critical for proper operation of the system. (See **Figure 15**) The sensor must be installed in a drywell in conjunction with heat conductive compound as shown in the following images. The drywell must be installed no more than 5 equivalent feet (1.5 m) of pipe/tubing downstream of the de-coupler and installed in such a way that ensures the sensor bulb is in the flow path.

Model No.	20°F (11.1°C) ΔT		30°F (16.7°C) ΔT		39°F (21.7°C) ΔT		Min. Flow			Max. Flow		
	gpm (lpm)	ΔP (ft)	gpm (lpm)	ΔP (ft)	gpm (lpm)	ΔP (ft)	gpm (lpm)	ΔP (ft)	ΔT	gpm (lpm)	ΔP (ft)	ΔT °F (°C)
992C	83 (314)	5.2	55 (208)	2.3	43 (163)	1.4	43 (163)	1.4	39 (21.7)	132 (500)	13.1	13 (7.2)
1262C	106 (401)	9.6	71 (269)	4.3	54 (204)	2.5	54 (204)	2.5	39 (21.7)	132 (500)	14.8	16 (8.9)
1532C	129 (488)	15.7	86 (326)	7.1	66 (250)	4.2	66 (250)	4.2	39 (21.7)	132 (500)	16.5	19 (10.6)
1802C			101 (382)	10.7	78 (295)	6.3	78 (295)	6.3	39 (21.7)	132 (500)	18.3	23 (12.8)
2002C			112 (424)	13.8	86 (326)	8.3	86 (326)	8.3	39 (21.7)	132 (500)	19.0	25 (13.9)
2072C			116 (439)	14.8	89 (337)	8.9	89 (337)	8.9	39 (21.7)	132 (500)	19.0	26 (58)
2342C			132 (500)	21.1	101 (382)	12.7	101 (382)	12.7	39 (21.7)	132 (500)	21.4	30 (16.7)

- Notes: 1. Basis for minimum flow is 40°F (22.2°C) ΔT. Basis for maximum flow is 132 GPM (500 lpm).
2. Rear-mounted pumps may provide higher flow rates on smaller models than the system requirements.

Table G. Heater Rates of Flow and Pressure Drops

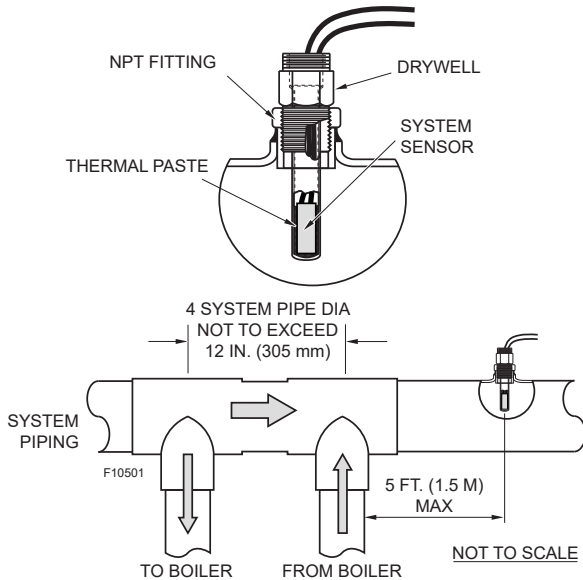

Figure 15. System Sensor Installation

Three-Way Valves

Valves designed to blend water temperatures or reduce water circulation through the heater should not be used. Raypak heaters are high-recovery, low-mass heaters which are not subject to thermal shock.

Applications & Modes

The VERSA IC® control system is designed for a wide range of applications. The installer/design engineer should refer to the following Modes to determine which best fits the intended application and functionality for the unit being installed.

Type H models of Hi Delta have three modes available to them to address the various applications the units can be applied to. Type WH and P units will only have one configuration available to them.

For detailed information on the VERSA IC® manual 241493. This manual can be found in the document library at www.raypak.com.

S1 - Outlet Sensor

S2 – Inlet Sensor

Mode 1 (Type H Units Only)

This mode selection is for hydronic heating systems with single or multiple boilers (refer to VERSA IC® manual 241493 for Cascade Operation) in primary/secondary piping configuration with or without Outdoor Air Reset (S4). The system temperature is controlled by the System sensor (S3). The Boiler Pump (P1) runs during any call for heat. The System Pump (P2) runs whenever the system is enabled for heating and the outdoor air temperature is lower than the warm weather shut down (WWSD) temperature setting (if utilized). The Boiler Pump is delayed “off” as user-defined in the BOILER menu and System Pump is delayed “off” as user-defined in the ADJUST menu (Illustration shows 4 boilers as a reference only).

NOTE: MODE 1 can also be used for process heating applications in conjunction with a buffer/storage tank when operating temperatures above 160°F (71°C) are required. Care must be given to ensure water hardness is no more than 15 grains per gallon for scale free operation.

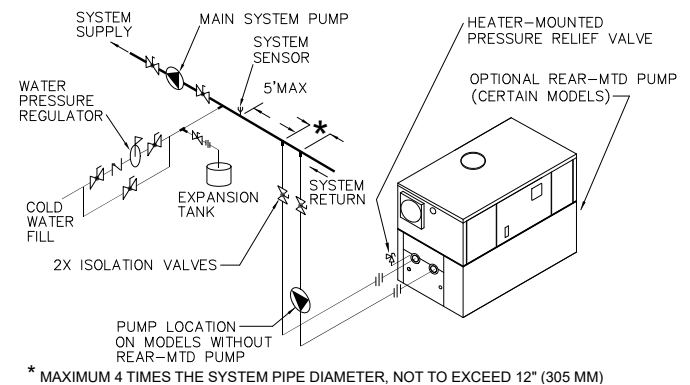

Figure 16. Single Heater - Space Heating Application with Primary/Secondary Piping

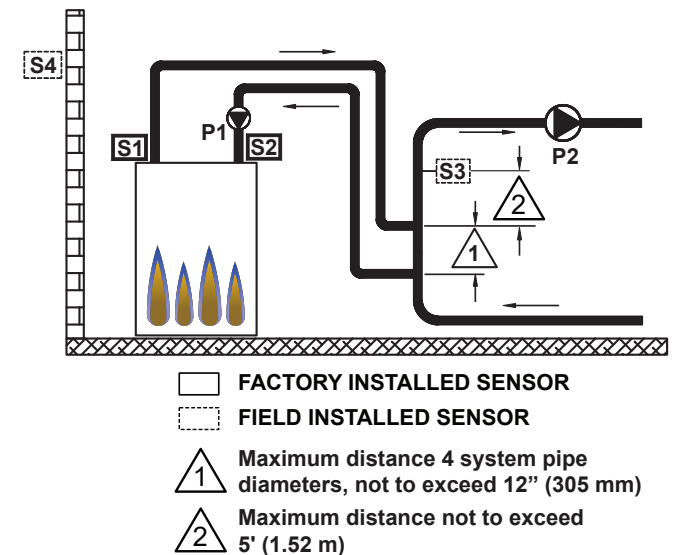

Figure 17. MODE 1 - Single Boiler with Primary/Secondary Piping

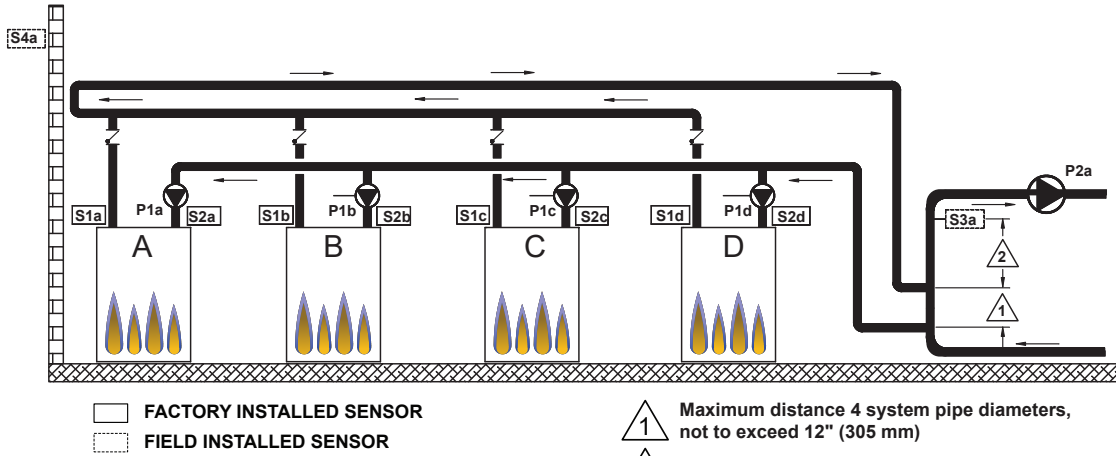

Figure 18. MODE 1 - Boiler Cascade with Primary/Secondary Piping

Mode 2 (Type H Units Only)

This mode selection is for hydronic heating systems with single or multiple boilers in primary/secondary piping configuration with or without Outdoor Air Reset (S4) with indirect DHW on the system loop (with or without priority). The system temperature is controlled by the System sensor (S3). The Indirect DHW sensor (S5) determines the indirect call/tank set-point. The system temperature is boosted to Target Max when using the Indirect DHW sensor (S5) during an indirect call for heat. Priority mode toggles off the System Pump (P2) when an indirect call for heat is present. The Boiler Pump (P1) runs during any call for heat. The Indirect DHW Pump (P3) runs during an indirect call for heat with no "off" delay. The Boiler Pump (P1) is delayed "off" as user-defined in the BOILER menu and System Pump (P2) delay "off" as user-defined in the ADJUST menu. The System Pump (P2) runs whenever the system is enabled for heating and the outdoor air temperature is lower than the WWSD temperature setting (if utilized) unless an indirect call for heat is present with priority.

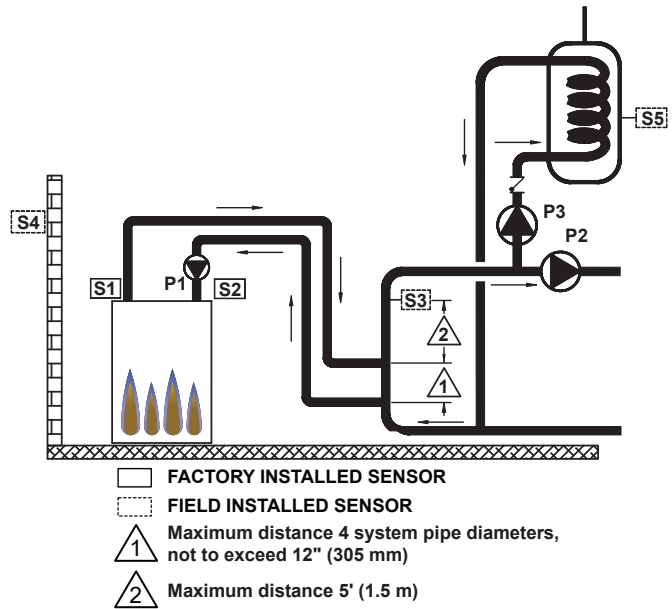

Figure 20. MODE 2 - Single Boiler with Indirect on System Loop

Mode 3 (Type H Units Only)

This mode selection is for hydronic heating systems with single or multiple boilers in primary/secondary piping configuration with or without Outdoor Air Reset (S4) with indirect DHW on the boiler loop (with priority). The system temperature is controlled by the Supply sensor (S3) whenever the indirect call for heat is not active. The DHW Supply sensor (S5) determines the indirect call/tank set-point. During an indirect call for heat the boiler firing rate is determined by the water temperature at the Indirect Supply sensor (S6) and the Target Max setting when using the Indirect DHW sensor (S5). The Boiler Pump (P1) runs during all heat calls regardless of priority. The Indirect DHW Pump (P3) runs during an indirect call for heat with no "off" delay. The Boiler Pump (P1) is delayed "off" as user-defined in the BOILER menu and System Pump (P2) delay "off" as user-defined in the ADJUST menu. The system pump (P2) runs whenever the system is enabled

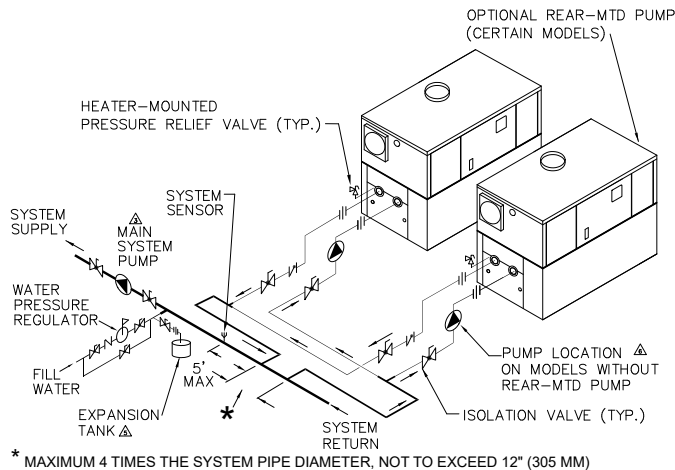

Figure 19. Dual Heaters (Reverse/Return) with Primary/Secondary Piping

for heating and the outdoor air temperature is lower than the WWSD temperature setting (if utilized) unless an indirect call for heat is present.

NOTE: A Tank Aquastat can be used in lieu of the Indirect DHW Sensor (S5). See the VERSA IC® manual 241493 for additional details.

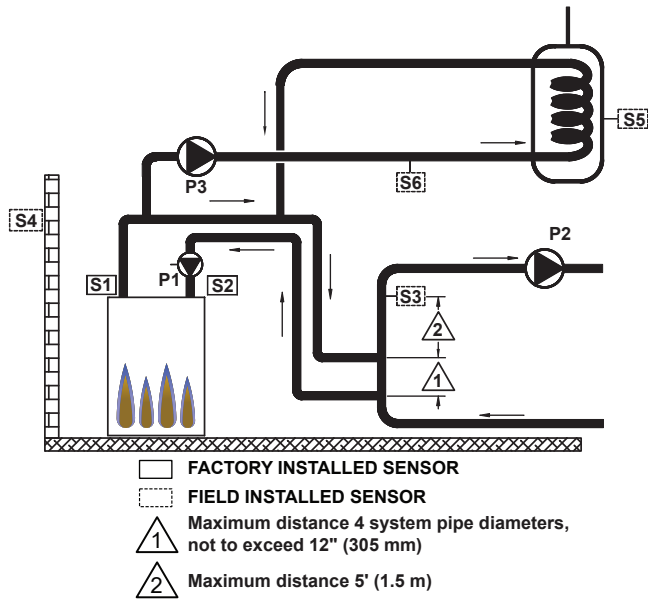

Figure 21. MODE 3 - Single Boiler with Indirect on Boiler Loop

Domestic Hot Water

WH models require a storage tank, as a condition of their certification. Any damage to the unit caused by operation without a properly-sized storage tank cannot be covered under warranty.

When designing the water piping system for domestic hot water applications, water hardness should be considered. **Table H** indicates the suggested flow rates for soft, medium and hard water. Water hardness is expressed in grains per gallon.

WH – Direct DHW Configuration

When the unit is ordered as a “WH” configuration the only application available to it is direct DHW with single or multiple heaters (Maximum 4 heaters), in conjunction with at least 1 storage tank. The tank temperature is controlled by the System sensor (S3). The Boiler Pump (P1) runs during any call for heat. The System Pump (P2) output is active whenever the system is enabled. The Boiler Pump is delayed “off” after the Tank Target temperature is achieved and as user defined in the BOILER menu.

NOTE: WH units will operate to a maximum tank setpoint of 160°F (71°C). For setpoints above 160°F (71°C), an “H” model boiler must be used and great care must be given to ensure water hardness is no more than 15 grains per gallon for scale-free operation. MODE 1 should be used and configured for set-point operation for process heating applications.

Model No.	Soft ¹ (3-4 grains per gallon)					Medium (5-15 grains per gallon)					Hard ¹ (16+ ² grains per gallon)				
	ΔT °F (°C)	GPM (lpm)	ΔP	MTS	SHL	ΔT °F (°C)	GPM (lpm)	ΔP	MTS	SHL	ΔT °F (°C)	GPM (lpm)	ΔP	MTS	SHL
992C	29 (16.1)	60 (227)	2.7	2½	5.2	17 (9.4)	98 (371)	7.3	2½	13.3	13 (7.2)	132 (500)	13.1	2½	23.6
1262C	29 (16.1)	72 (273)	4.4	2½	7.9	19 (10.6)	115 (435)	11.3	2½	19.4	16 (8.9)	132 (500)	14.8	2½	25.3
1532C	29 (16.1)	86 (326)	7.1	2½	11.9	22 (12.2)	120 (454)	13.7	2½	22.5	20 (11.1)	132 (500)	16.5	2½	27.0
1802C	29 (16.1)	102 (386)	10.9	2½	17.4	26 (14.4)	120 (454)	15.1	2½	23.9	23 (12.8)	132 (500)	18.3	2½	28.7
2002C	29 (16.1)	112 (424)	13.9	2½	21.6	26 (14.4)	132 (500)	19.0	2½	29.5	26 (14.4)	132 (500)	19.0	2½	29.5
2072C	31 (17.2)	117 (443)	15.1	2½	23.4	27 (15.0)	132 (500)	19.0	2½	29.5	27 (15.0)	132 (500)	19.0	2½	29.5
2342C	33 (18.3)	120 (454)	17.8	2½	26.5	30 (16.7)	132 (500)	21.4	2½	31.8	30 (16.7)	132 (500)	21.4	2½	31.8

ΔT = Temperature rise, °F (°C)

ΔP = Pressure drop through heat exchanger, ft

SHL = System head loss, ft. Includes 50 eq ft (15.2 m) of tubing each way (total 100 eq ft [30.5 m])

gpm = Gallons per minute (lpm), flow rate

MTS = Minimum tubing size

¹ Must utilize optional cupronickel tubes.

² If over 25 grains per gallon, a water softener/treatment system must be utilized.

Caution: For scale-free operation with “Hard Water” (16-25 grains per gallon of total hardness), the operating control must NOT be set higher than 130°F (54.4°C). For higher than 130 °F (54.4°C) operation, a water softener/treatment system must be utilized.

Caution: Water softened to less than 0-3 grains per gallon is known to be aggressive and corrosive.

Table H. Domestic Water Heater Flow Rate Requirements

NOTE: If local codes require a vacuum relief valve, acquire one locally and install per valve manufacturer's instructions.

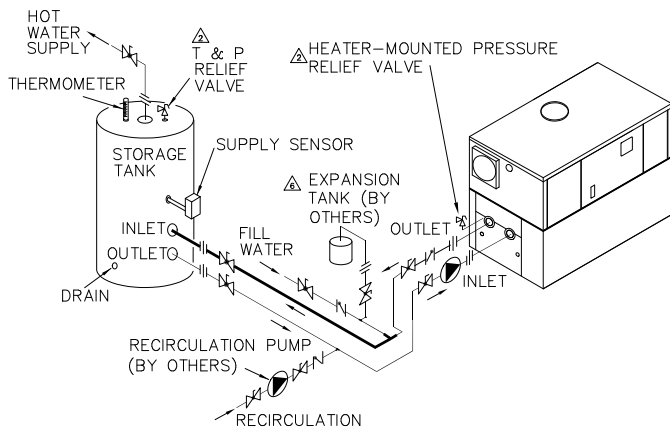

Figure 22. Single Domestic Hot Water Heater and Storage Tank

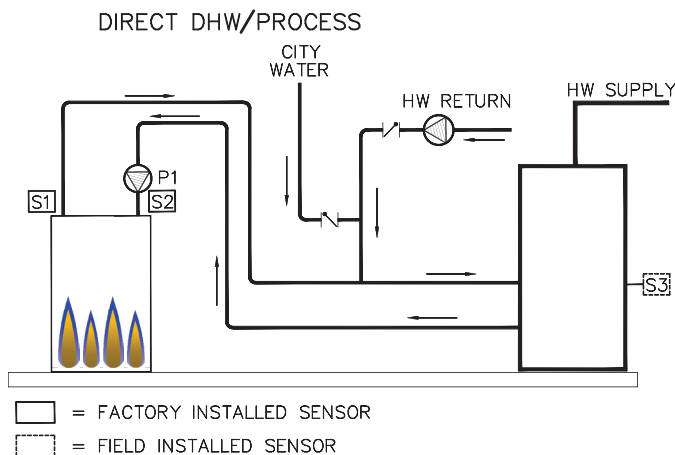

Figure 23. WH Units - Single Water Heater with Tank H Units - Single Boiler with Process Tank

Potable Water and Space Heating

CAUTION: When this heater is used for both potable water and space heating, observe the following to ensure proper operation.

1. All piping materials and components connected to the water heater for the space heating application shall be suitable for use with potable water.
2. Toxic chemicals, such as used for boiler treatment, shall not be introduced into the potable water used for space heating.
3. If the heater will be used to supply potable water, it shall not be connected to any heating system or components previously used with a non-potable water heating appliance.
4. When the system requires water for space heating at temperatures higher than 140°F (60°C), a means such as a mixing valve shall be installed to temper the water in order to reduce scald hazard potential.

Automatic Chemical Feeders

All chemicals must be introduced and completely diluted into the water before being circulated through the heater. High chemical concentrations will result when the pump is not running (e.g. overnight).

NOTE: High chemical concentrates from feeders that are out of adjustment will cause rapid corrosion to the heat exchanger. Such damage is not covered under the warranty.

NOTE: Failure of a heat exchanger due to lime scale build-up on the heating surface, low pH or other chemical imbalance is non-warrantable.

CAUTION: Combustion air must not be contaminated by corrosive chemical fumes which can damage the heater and void the warranty.

Pool Heating

CAUTION: Power to the heater should be interlocked with the main system pump to make sure the heater does not fire without the main system pump in operation. Improper flow control can damage the heater. Uncontrolled flow (too high) or restricted flow (too low) can seriously damage the heater. Follow these instructions to make sure your heater is properly installed.

All Raypak pool heaters are certified to ANSI Z21.56, which is the nationally-recognized standard for swimming pool heaters. Some heaters being sold in the marketplace for heating commercial swimming pools are often certified as hot water boilers or water heaters. Regardless of which standard they are certified to, they are generally trimmed out either by the manufacturer or the installer with controls that are suitable for maintaining normal swimming pool temperatures and water conditions.

The P-992C-2342C models are configured to accommodate locating the outlet temperature controller in the pool system piping that supplies the heated water to the pool. This arrangement facilitates controlling or limiting the temperature of the water supplied to the pool. The heater must be plumbed in a primary/secondary arrangement, wherein only a portion of the water flowing in the piping system is pulled off, heated, and then returned to the system. The water coming out of the heater is mixed with the filtered water in the main pipe and thus tempered before returning to the pool. This arrangement permits operation of the heater at a temperature range that has been optimized both to avoid forming condensation on the heat exchanger and to mitigate the formation of scale in the heat exchanger tubes.

For a Pool heating application, always verify that the Hi Delta unit has been ordered as a pool heater. To avoid issues related to high temperatures not appropriate to a pool application.

NOTE: The recommended setting for the outlet thermostat is 110°F (43°C).

The Hi Delta pool heater is offered with bypass options: automatic thermostatic valve and copper bypass, or automatic Cold Water Run (CWR) bypass made of CPVC. These arrangements both blend outlet water with the inlet water to increase the inlet water temperature, thereby reducing the likelihood of condensation forming on the heat exchanger. The pump also serves to circulate water through the heater from the main system piping.

To complete installation of the heater, the system sensor (S3) must be installed in the return water line, upstream of the heater. The supplied electronic operating control is configured to operate as the poolstat. A separate sensor (S6) is shipped loose to be installed in the system piping downstream of the heater outlet. See **Figure 24** for the poolstat/sensor location.

WARNING: To ensure safe operation of the Hi Delta heater, all plumbing from the heater to the main loop must be CPVC, copper or brass.

Install limit in supply to pool as shown in **Figure 24**. For data on acceptable pool chemistry, see **Table I**.

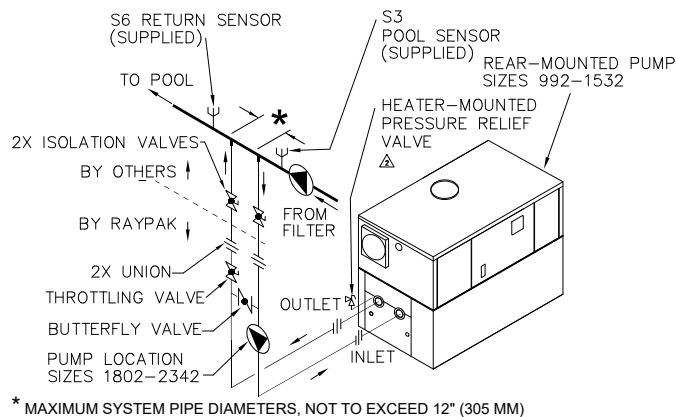

Figure 24. Single Pool Heater Application

H-Bypass (Standard)

Adjustment of the manual bypass valve is critical to proper operation of the heater. The manual bypass valve should be adjusted to achieve a minimum inlet water temperature of 105°F (40.5°C) and an outlet water temperature below 140°F (60°C). When starting with a cold pool, make initial adjustments. Make final adjustments when pool water approaches desired temperature.

The use of a bypass is required for proper operation in a pool heating application. Refer to **Figure 24**. Use the following instructions to set the manual bypass:

1. Set Valve A (the bypass) to 1/2 open position, and Valve B to fully open position.
2. Turn on pump.
3. Turn on heater and wait until heater goes to full fire.

4. Adjust Valve A until the inlet water temperature is 105°F (40.5°C).

NOTE: Opening the valve will increase the temperature and closing the valve will decrease the temperature.

5. If this process does not raise the inlet water temperature to 105°F (40.5°C) and Valve A is fully open, then slowly throttle Valve B closed to increase the inlet water temperature to 105°F (40.5°C).

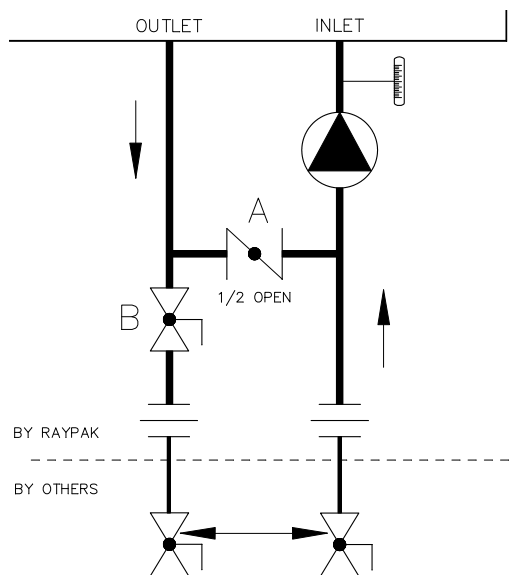

Figure 25. "H" Bypass Adjustment

Automatic Cold Water Protection (Optional)

P models use a variable-speed pump to maintain the inlet water temperature 105°F (40.5°C).

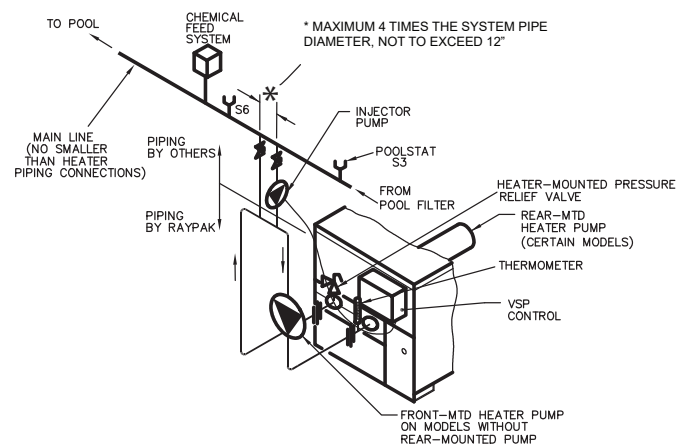

Figure 26. Single Pool Heater - Automatic Bypass

Winterizing Your Heater

Heaters installed outdoors in freezing climate areas should be shut down for the winter. To shut down heater, turn off manual main gas valve and main gas shut-off. Close isolation valves and remove water piping from the in/out header on the heater. Drain the heater and any piping of all water that may experience below-freezing temperatures.

Pool/Spa Water Chemistry

NOTE: Chemical imbalance can cause severe damage to your heater and associated equipment.

pH of Water

pH is a measure of relative acidity, neutrality or alkalinity. Dissolved minerals and gases affect water's pH. The pH scale ranges from 0 to 14. Water with a pH of 7.0 is considered neutral. Water with a pH lower than 7 is considered acidic. Water with a pH higher than 7 is considered alkaline. A neutral pH (around 7) is desirable for most potable water applications. Corrosion damage and water heater failures resulting from water pH levels of lower than 6 or higher than 8 are non-warrantable. The ideal pH range for water used in a storage tank or a copper water heater system is 7.2 to 7.8.

Total Dissolved Solids

Total dissolved solids (TDS) is the measure of all minerals and solids that are dissolved in the water. The concentration of total dissolved solids is usually expressed in parts per million (ppm) as measured in a water sample. Water with a high TDS concentration will greatly accelerate lime and scale formation in the hot water system. Most high TDS concentrations will precipitate out of the water when heated. This can generate a scale accumulation on the heat transfer surface that will greatly reduce the service life of a pool heater. This scale accumulation can also impede adequate flow of water and may totally block the water passages in the tubes of the heat exchanger. A heat exchanger that is damaged or blocked by lime/scale accumulation must be replaced. Failure of a water heater due to lime scale build up on the heating surface is non-warrantable. The manufacturer of the pool heater has no control of the water quality, especially the TDS levels in your system. Total dissolved solids in excess of 1,500 ppm will accelerate lime and scale formation in the heat exchanger.

Heat exchanger failure due to total dissolved solids in excess of 1,500 ppm is a non-warrantable condition.

NOTE: Failure of a heat exchanger due to lime scale build-up on the heating surface, low pH or other chemical imbalance is non-warrantable.

Gas Supply

⚠ DANGER: Make sure the gas on which the heater will operate is the same type as specified on the heater's rating plate.

Gas piping must have a sediment trap ahead of the heater gas controls, and a manual shutoff valve located outside the heater jacket. It is recommended that a union be installed in the gas supply piping adjacent to the heater for servicing. A pounds-to-inches regulator must be installed to reduce the gas supply pressure to a maximum of 10.5 in. WC for natural gas and 13.0 in. WC for propane gas. The regulator should be placed a minimum distance of 10 times the pipe diameter upstream of the heater gas controls. Refer to **Table J** for maximum pipe lengths.

Model No.	2"		2-1/2"		3"		4"	
	NAT ft. (m)	PRO ft. (m)	NAT ft. (m)	PRO ft. (m)	NAT ft. (m)	PRO ft. (m)	NAT ft. (m)	PRO ft. (m)
992C	120 (36.6)	300 (91.4)	300 (91.4)					
1262C	75 (22.9)	180 (54.9)	170 (51.7)	325 (99.1)	560 (170.7)			
1532C	50 (15.2)	120 (36.6)	125 (38.1)	250 (76.2)	400 (121.9)			
1802C	40 (12.2)	100 (30.5)	100 (30.5)	225 (36.1)	340 (103.6)			
2002C	30 (9.1)	80 (24.4)	75 (22.9)	175 (53.3)	260 (79.2)			
2072C	30 (9.1)	80 (24.4)	75 (22.9)	175 (53.3)	260 (79.2)			
2342C	20 (6.1)	55 (16.8)	55 (16.8)	135 (41.1)	160 (48.8)	400 (121.9)	600 (182.9)	

Natural gas – 1,000 BTU per ft³, 0.60 specific gravity at 0.5 in. WC pressure drop

Propane gas – 2,500 BTU per ft³, 1.53 specific gravity at 0.6 in. WC pressure drop

Elbow = 10 ft (3.3 m) effective length

Table J. Gas Supply Piping

Recommended Level(s)	Fiberglass Pools	Fiberglass Spas	Other Pool and Spa Types
Water Temperature	68-88°F (20-31°C)	89-104°F (31-40°C)	68-104°F (20-40°C)
pH	7.3-7.4	7.3-7.4	7.6-7.8
Total Alkalinity (ppm)	120-150	120-150	80-120
Calcium Hardness (ppm)	200-300	150-200	200-400
Salt (ppm)	3000 Maximum	3000 Maximum	3000 Maximum
Free Chlorine (ppm) ¹	2-3	2-3	2-3
Total Dissolved Solids (ppm)	1500 Maximum ²	1500 Maximum ²	1500 Maximum ²

¹ Free Chlorine MUST NOT EXCEED 5 ppm!

² In salt water chlorinated pools, the total TDS can be as high as 4500 ppm.

NOTE: The allowable concentrations of salt and of the Total Dissolved Solids are lower for the Hi Delta than for a typical residential pool heater, due to the higher water temperatures at which a Hi Delta operates.

Table I. Water Chemistry

Gas Supply Connection

CAUTION: The heater must be disconnected from the gas supply during any pressure testing of the gas supply system at test pressures in excess of 1/2 psi (3.45 kPa).

The heater must be isolated from the gas supply piping system by closing the manual shutoff valve during any pressure testing of the gas supply piping system at test pressures equal to or greater than 1/2 psi (3.45 kPa). Relieve test pressure in the gas supply line prior to reconnecting the heater and its manual shutoff valve to the gas supply line. **FAILURE TO FOLLOW THIS PROCEDURE MAY DAMAGE THE GAS VALVES.** Over-pressurized gas valves are not covered by warranty. The heater and its gas connections shall be leak-tested before placing the appliance in operation. Use soapy water for leak test. DO NOT use an open flame.

CAUTION: Do not use Teflon tape on gas line pipe thread. A pipe compound rated for use with natural and propane gases is recommended. Apply sparingly only on male pipe ends, leaving the two end threads bare.

CAUTION: Support gas supply piping with hangers, not by the heater or its accessories. Make sure the gas piping is protected from physical damage and freezing, where required.

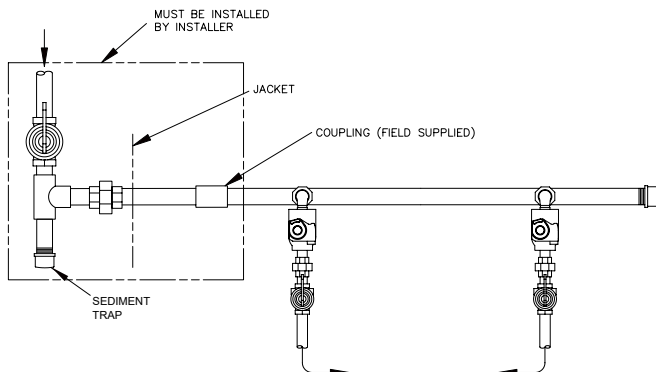

Figure 27. Gas Supply Connection

Reversing Gas Supply Connection

Reversing the standard fuel connection from the left-hand to the right-hand side is a simple field operation.

1. Disconnect all electrical power from the heater (if applicable).
2. Disconnect the main gas pipe from the heater (if applicable).
3. Remove the left and right front panels from the heater.
4. Locate the main gas line that traverses across the heater above the manifold risers.
5. Remove the pipe cap from the right-hand end of the main gas line.
6. Reinstall the pipe cap on the left-hand end of the main gas line.

7. Remove the rubber grommet from the left-hand-side panel and reinstall into the standard main gas opening, located on the right-hand side of the heater.
8. Remove plastic cap from the right-hand side panel and reinstall into the standard main gas opening located on the left-hand side of the heater.
9. Install a coupling, nipple, union and sediment trap onto the right-hand end of the main gas line and then install the gas line, making sure that a manual shut-off valve has been installed within 10 ft (3.3 m) of the heater.
10. Replace the left and right front panels on the heater.

Gas Supply Pressure

A minimum of 5.6 in. WC upstream gas pressure under full load and a maximum gas supply pressure set point of 10.5 in. WC under load and no-load conditions are required for natural gas. A minimum of 11.0 in. WC upstream gas pressure under full load and a maximum gas supply pressure set point of 13.0 in. WC are required for propane gas. The gas pressure regulator(s) supplied on the heater is for low-pressure service. If upstream pressure exceeds 14.0 in. WC (1/2 psi) at any time, an intermediate gas pressure regulator, of the lockup type, must be installed.

When connecting additional gas utilization equipment to the gas piping system, the existing piping must be checked to determine if it has adequate capacity for the combined load.

The gas valve pressure regulator(s) on the heater are nominally preset at 3.5 in. WC for natural gas, and 10.5 in. WC for propane gas. The pressure at the gas valve outlet tap, measured with a manometer, while in operation should be 3.5 ± 0.1 in. WC for natural gas and $10.5 \text{ in.} \pm 0.1 \text{ in.}$ WC for propane gas. If an adjustment is needed, remove the adjustment screw cover and turn the adjustment screw clockwise to increase pressure or counter-clockwise to lower pressure.

NOTE: The maximum allowable pressure drop from static to dynamic at full fire is 30%.

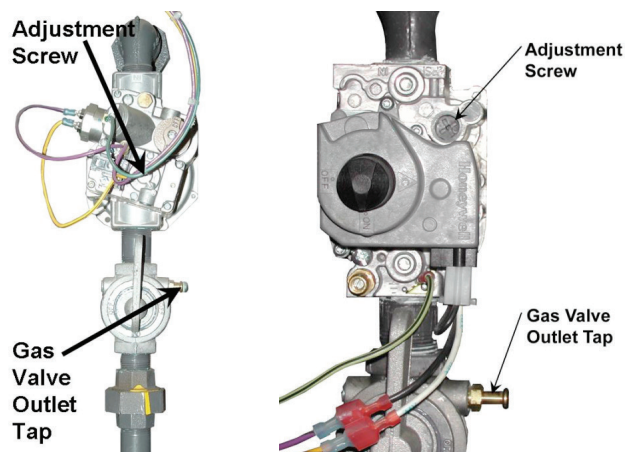

Figure 28. Gas Valves

Electrical Power Connections

Installations must follow these codes:

- National Electrical Code and any other national, state, provincial or local codes or regulations having jurisdiction.
- Safety wiring must be NEC Class 1.
- Heater must be electrically grounded as required by the NEC.
- In Canada, CSA C22. 1 C.E.C. Part 1.

The heater is wired for 120 VAC, less than 8 amps in its basic configuration. Additional options may increase the amp draw of the unit. The voltage is indicated on the tie-in leads. Consult the wiring diagram shipped with the heater in the instruction packet. Before starting the heater check to ensure proper voltage to the heater and pump.

Pumps over 3/4 HP require separate connections and separate circuit breakers, or a significantly larger circuit to handle the combined loads of the boiler and the pump. Both loads involve motors and the circuit breakers should be motor-rated types. See the wiring diagram.

Install a separate disconnect means for each load. Use appropriately sized wire as defined by NEC, CSA and/or local code. All primary wiring should be at least 125% of minimum rating.

If any of the original wire as supplied with the heater must be replaced, it must be replaced with 105°C wire or its equivalent.

Check the Power Source

⚠ WARNING: Using a multi-meter, check the following voltages at the terminal block inside the unit. Make sure proper polarity is followed and house ground is proven. (See Figure 29.)

NOTE: Minimum 18 AWG, 105°C, stranded wire must be used for all low voltage (less than 30 volts) external connections to the unit. Solid conductors should not be used because they can cause excessive tension on contact points. Install conduit as appropriate. All high voltage wires must be the same size (105°C, stranded wire) as the ones on the unit or larger.

NOTE: A grounding electrode conductor shall be used to connect the equipment grounding conductors, the equipment enclosures, and the grounded service conductor to the grounding electrode.

Check the power source:

- AC = 108 VAC Minimum, 132 VAC MAX
- AB = 108 VAC Minimum, 132 VAC MAX
- BC = less than 1 VAC Maximum

Making the Electrical Connections

Refer to **Figure 29** through **Figure 32**.

1. Verify that circuit breaker is properly sized by referring to heater rating plate. A dedicated circuit breaker should be provided.
2. Turn off all power to the heater. Verify that power has been turned off by testing with a multi-meter prior to working with any electrical connections or components.
3. Observe proper wire colors while making electrical connections. Many electronic controls are polarity sensitive. Components damaged by improper electrical installation are not covered by warranty.
4. Provide overload protection and a disconnect means for equipment serviceability as required by local and state code.
5. Install heater controls, thermostats, or building management systems in accordance with the applicable manufacturers' instructions.
6. Conduit shall not be used as the earth ground.

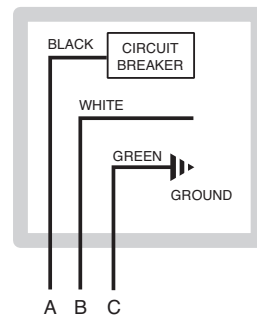

Figure 29. Wiring Connections

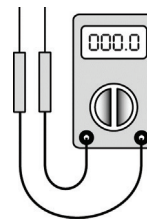

Figure 30. Multi-meter

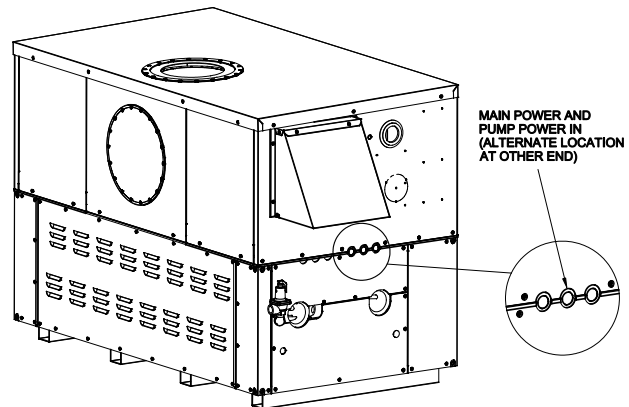

Figure 31. Wiring Location

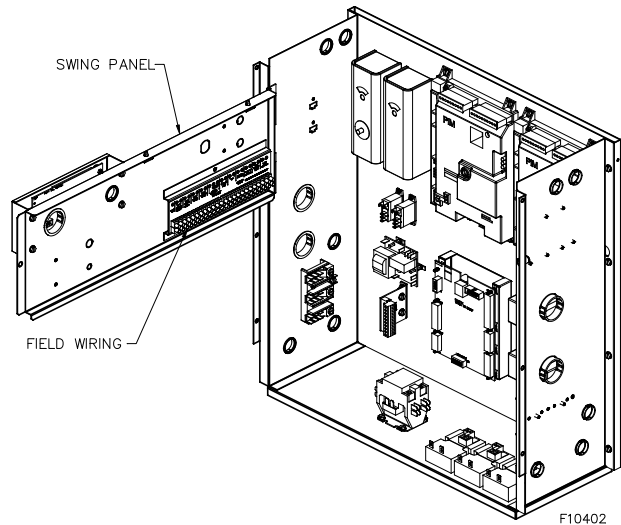

Figure 32. Low Voltage Field Wiring Location

Field Wiring Connection

CAUTION: Label all wires prior to disconnection when servicing controls. Wiring errors can cause improper and dangerous operation. Verify proper operation after servicing.

NOTE: Do not combine low and high voltage in the same conduit.

DANGER: SHOCK HAZARD!

Make sure electrical power to the heater is disconnected to avoid potential serious injury or damage to components.

Wiring the Enable/Disable

Connect the Enable/Disable wiring (terminals 11 and 12) to the field wiring terminals (VERSA IC[®] manual 241493). Alternately, any dry contact closure (including a remote thermostat) across these terminals will enable the Hi Delta unit to run. Caution should be used to ensure neither of the terminals becomes connected to ground.

Wiring the Outdoor Sensor

1. There is no connection required if an outdoor sensor is not used in this installation.
2. If using an Outdoor Sensor (option B-32), connect the sensor wires to the terminals marked OUTDOOR SENSOR (see VERSA IC[®] manual 241493). Caution should be used to ensure neither of these terminals becomes connected to ground.
3. Use a minimum 18 AWG wire for runs of up to 150 feet.
4. Mount the outdoor sensor on an exterior surface of the building, preferably on the north side in an area that will not be affected by direct sunlight and that will be exposed to varying weather conditions.

Wiring the Indirect Sensor

1. An indirect sensor connection is not required if an indirect water heater is not used in the installation.
2. When the Indirect DHW call for heat is active, the PIM communicates this to the VERSA. The VERSA calculates the optimal operation and sends the firing rate and pump output requests to the PIM so it can activate the Indirect DHW pump and Boiler pump as needed. If an optional Indirect DHW sensor is connected, the PIM will pass this signal to the VERSA. This allows the VERSA to optimize the Indirect DHW demand to maintain the Indirect DHW set-point. The Indirect DHW thermostat switch closure is still required when using the Indirect DHW sensor. If a VERSA is not present the PIM shall activate the Indirect DHW pump whenever the Indirect DHW call is active. The Boiler pump will also be activated based on the Indirect DHW piping configuration setting. Consult the VERSA IC[®] manual (241493) for additional configurations.
3. Connect the indirect tank sensor to the terminals marked INDIRECT DHW SENSOR (see wiring diagram). Caution should be used to ensure neither of these terminals becomes connected to ground. When using an indirect DHW sensor to control tank temperature contact closure is required across the indirect override connections for proper operation during “limp along” mode set PIM operator dial to be equal to DHW Target temperature to prevent an over temperature condition from occurring.

NOTE: Alternately, a thermostat contact closure can be used in lieu of the sensor for indirect operation. Connect the thermostat to the terminals marked INDIRECT DHW OVERRIDE.

CAUTION: Sensor and control wiring must NOT be run in conduit or chases with line voltage.

Wiring the Optional 0–10 Volt Building Control Signal

1. A signal from an energy management system may be connected to the Hi Delta boiler. This signal should be a 0-10 volt positive DC signal, and an energy management system can be used to control either the set-point temperature of a single Hi Delta or a cascade of multiple boilers, or the firing rate of a single Hi Delta boiler (see VERSA IC[®] manual 241493 for details on Cascade Systems).
2. To enable this remote control function, set dip switch 5 to the UP position on the PIM. DIP switch 5 Toggles between an EMS (UP) signal or a demand signal from the VERSA (DOWN). DIP switch 2 on the PIM toggles between a Direct Drive (UP) input and a Target Temperature (DOWN) set-point.

- For a 4-20 mA application, refer to the VERSA IC® manual (241493).
- Connect an Energy Management system or other auxiliary control signal to the terminals marked 0-10V (+/-) on the field wiring terminals (see VERSA IC® manual 241493). Caution should be used to ensure that the +0-10V connection does not create a short to ground.

Wiring the Cascade System Communication Bus

Refer to VERSA IC® manual (241493) for details on Cascade wiring and communication setup.

Cascade System Pump and Sensor Wiring

- On the boiler designated as the Master, connect the system pump enable wiring to the terminal block in the control panel. The connections are dry contacts rated for pilot duty only (5A maximum).
- Connect the boiler pump enable wires to the terminal block in the control panel. The connections are dry contacts rated for pilot duty only (5A maximum).
- Connect the system supply sensor to terminals 6 and 7 on the field wiring strip located on the Master PIM (See VERSA IC® manual 241493).
- Connect the Outdoor sensor (if used) to terminals 8 and 9 on the field wiring strip located on the Master boiler (See VERSA IC® manual 241493).
- Connect the Enable/Disable wiring to terminals 11 and 12 on the field wiring strip located on the Master boiler (See VERSA IC® manual 241493). This connection must be provided through dry contacts closure.

NOTE: This dry contacts closure can come from a room thermostat or a remote relay. No power of any kind should be applied to either of these terminals.

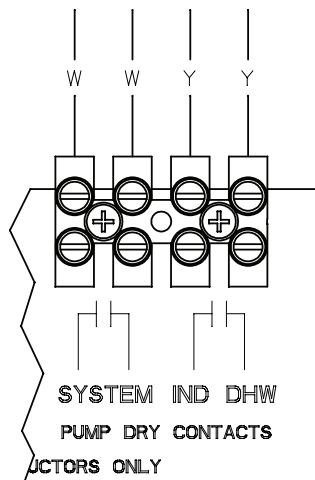

Figure 33. Cascade Master Pumps

Cascade Follower Pump and Sensor Wiring

- Once the primary boiler has been identified, additional boilers will be designated as follower boilers. Ensure dip switch 2 on each follower VERSA is set to the OFF/Down position.
- For each follower boiler, connect the boiler pump enable wires to the terminal block at the rear of each unit. The connections are dry contacts rated for pilot duty only (5A maximum).
- For Cascade configurations System pump (all models) and DHW pump (H models) Follower outputs must be connected in parallel order to support operation during "Limp Along" mode. For detailed wiring instructions see VERSA IC® manual (241493).

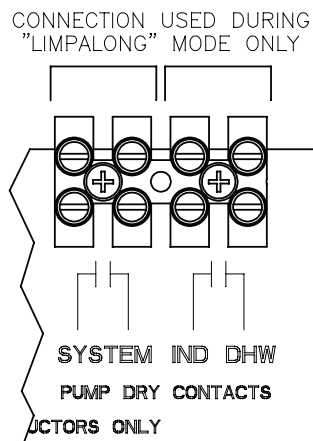

Figure 34. VERSA Follower

Modbus BMS Communication

The VERSA IC® control is equipped as standard with a communications port for connectivity to building automation via Modbus protocol. Refer to the VERSA IC® manual (241493) for further information.

Alarm Connection

An alarm annunciator or light may be connected to the alarm contacts on the field wiring terminal strip. The Alarm Contacts are 3A rated dry contacts on a normally-open relay that close during fault or lockout conditions, and the maximum voltage across the contacts is 30 VAC or 30 VDC. See the Field Wiring as shown in VERSA IC® manual (241493).

In a cascade system, in the event of an alarm condition at one or more units, all alarm contacts within the cascade will be energized indicating a fault condition. This feature can be enabled or disabled, refer to VERSA IC® manual (241493) for further details on "Cascaded Alarm".

Venting

CAUTION: Proper installation of flue venting is critical for the safe and efficient operation of the heater.

General

Flue Exhaust Tee

An optional Flue Exhaust Tee (sales option D-14) is available to facilitate horizontal venting (See **Figure 35**). Any venting that exits the back of the heater requires this tee. Refer to **Table K** for the appropriate kit for your model.

Model	Diameter	Order Number
992C	10"	011841
1262C, 1532C	12"	011842
1802C, 2002C, 2072C	14"	011843
2342C	16"	011844

Table K. D-14 Flue Exhaust Tee Kits

Appliance Categories

Heaters are divided into four categories based on the pressure produced in the exhaust and the likelihood of condensate production in the vent.

Category I – A heater which operates with a non-positive vent static pressure and with a vent gas temperature that avoids excessive condensate production in the vent.

Category II – A heater which operates with a non-positive vent static pressure and with a vent gas temperature that may cause excessive condensate production in the vent.

Category III – A heater which operates with a positive vent pressure and with a vent gas temperature that avoids excessive condensate production in the vent.

Category IV – A heater which operates with a positive vent pressure and with a vent gas temperature that may cause excessive condensate production in the vent.

See **Table L** for appliance category requirements.

Hi Delta units have internal fans, and carrying capacity for CAT I vents is determined using the 'Fan' column.

NOTE: For additional information on appliance categorization, see appropriate ANSI Z21 Standard and the NFGC (U.S.), or B149 (Canada), or applicable provisions of local building codes.

CAUTION: When condensate traps are installed, condensate must be routed to an appropriate container for treatment before disposal, as required by local codes.

CAUTION: Condensate is acidic and highly corrosive.

WARNING: Contact the manufacturer of the vent material if there is any question about the appliance categorization and suitability of a vent material for application on a Category III or IV vent system. Using improper venting materials can result in personal injury, death or property damage.

Support of Vent Stack

The weight of the vent stack or chimney must not rest on the heater vent connection. Support must be provided in compliance with applicable codes. The vent should also be installed to maintain proper clearances from combustible materials.

Use insulated vent pipe spacers where the vent passes through combustible roofs and walls.

NOTE: During winter months check the vent cap and make sure no blockage occurs from build-up of snow or ice.

Vent Terminal Location

1. Condensate can freeze on the vent cap. Frozen condensate on the vent cap can result in a blocked flue condition.
2. Give special attention to the location of the vent termination to avoid possibility of property damage or personal injury.
3. Gases may form a white vapor plume in winter. The plume could obstruct a window view if the termination is installed near windows.
4. Prevailing winds, in combination with below-freezing temperatures, can cause freezing of condensate and water/ice build-up on buildings, plants or roofs.
5. The bottom of the vent terminal and the air intake shall be located at least 12 in. (30.5 cm) above grade, including normal snow line.
6. Un-insulated single-wall metal vent pipe shall not be used outdoors in cold climates for venting gas-fired equipment.
7. Through-the-wall vents for Category II and IV appliances and non-categorized condensing appliances shall not terminate over public walkways or over an area where condensate or vapor could create a nuisance or hazard or could be detrimental to the operation of regulators, relief valves, or other equipment. Where local experience indicates that condensate is a problem with Category I and III appliances, this provision shall also apply.
8. Locate and guard vent termination to prevent accidental contact by people or pets.
9. DO NOT terminate vent in window well, stairwell, alcove, courtyard or other recessed area.

10. DO NOT terminate above any door, window, or gravity air intake. Condensate can freeze, causing ice formations.
11. Locate or guard vent to prevent condensate from damaging exterior finishes. Use a rust-resistant sheet metal backing plate against brick or masonry surfaces.
12. DO NOT extend exposed vent pipe outside of building. Condensate could freeze and block vent pipe.

U.S. Installations

Refer to the latest edition of the National Fuel Gas Code.

Vent termination requirements are as follows:

1. Vent must terminate at least 4 ft (1.2 m) below, 4 ft (1.2 m) horizontally from or 1 ft (30.5 cm) above any door, window or gravity air inlet to the building.
2. The vent must not be less than 7 ft (2.1 m) above grade when located adjacent to public walkways.
3. Terminate vent at least 3 ft (0.9 m) above any forced air inlet located within 10 ft (3 m).
4. Vent must terminate at least 4 ft (1.2 m) horizontally, and in no case above or below unless 4 ft (1.2 m) horizontal distance is maintained, from electric meters, gas meters, regulators, and relief equipment.
5. Terminate vent at least 6 ft (1.8 m) away from adjacent walls.
6. DO NOT terminate vent closer than 3 ft (91 cm) below roof overhang.
7. The vent terminal requires a 12 in. (30.5 cm) vent terminal clearance from the wall.
8. Terminate vent at least 1 ft (30.5 cm) above grade, including normal snow line.
9. Multiple direct vent installations require a 4 ft (1.2 m) clearance between the ends of vent caps located on the same horizontal plane.

Canadian Installations

Refer to latest edition of B149 Installation code.

A vent shall not terminate:

1. Directly above a paved sidewalk or driveway which is located between two single-family dwellings and serves both dwellings.
2. Less than 7 ft (2.13 m) above a paved sidewalk or paved driveway located on public property.
3. Within 6 ft (1.8 m) of a mechanical air supply inlet to any building.
4. Above a meter/regulator assembly within 3 ft (915 mm) horizontally of the vertical centre-line of the regulator.
5. Within 6 ft (1.8 m) of any gas service regulator vent outlet.
6. Less than 1 ft (30.5 cm) above grade level.
7. Within 3 ft (91.5 cm) of a window or door which can be opened in any building, any non-mechanical air supply inlet to any building or the combustion air inlet of any other appliance.
8. Underneath a veranda, porch or deck, unless the veranda, porch or deck is fully open on a minimum of two sides beneath the floor, and the distance between the top of the vent termination and the underside of the veranda, porch or deck is greater than 1 ft (30.5 cm).

Changing the Flue Outlet

The flue connection may be changed from the top to the rear of the heater using the optional flue exhaust tee kit, sales order option D-14 (see **Figure 35**). Follow the directions given in the Flue Exhaust Tee kit instruction, (241290).

CAUTION: The silicone vent gaskets must be properly reinstalled to prevent flue gas leakage. Replace any torn or worn vent gaskets.

Combustion Air Supply	Exhaust Configuration	Heater Venting Category	Certified Materials	Combustion Air Inlet Material
From Inside Building (Room Air)	Vertical Natural Draft Venting	I FAN	"B" Vent	
	Horizontal Through-the-Wall Venting	III	Stainless Steel (Gas Tight)	
From Outside Building (Ducted Air)	Vertical Natural Draft Venting	I FAN	"B" Vent	Galvanized Steel PVC ABS CPVC
	Horizontal Through-the-Wall Venting	III	Stainless Steel (Gas Tight)	

Table L. Venting Category Requirements

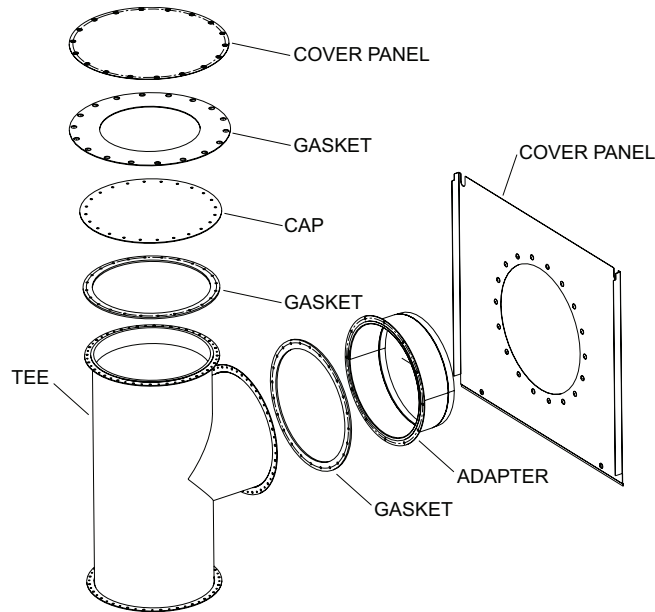

Figure 35. D-14 Flue Exhaust Tee Kit

Venting Installation Tips

Support piping:

- horizontal runs - at least every 5 ft (1.5 m)
- vertical runs - use braces
- under or near elbows

⚠ WARNING: Examine the venting system at least once a year. Check all joints and vent pipe connections for tightness, corrosion or deterioration.

Venting Configurations

For heaters connected to gas vents or chimneys, vent installations shall be in accordance with the NFGC (U.S.), or B149 (Canada), or applicable provisions of local building codes.

Vertical Venting (Category I, Fan Assisted) Installation

Category I fan-assisted venting uses the natural buoyancy of the heated flue products, in combination with the pressure of the fan pressuring the incoming air, to create a thermal driving head that expels the exhaust gases from the flue. The negative draft must be within the range of $-.01$ to $-.08$ in. WC as measured 12 in. (30.5 cm) above the appliance flue outlet to ensure proper operation. Vent material must be listed by a nationally recognized test agency. The maximum and minimum venting length for Category I appliances shall be determined per the NFGC (U.S.) or B149 (Canada).

The diameter of vent flue pipe should be sized according to the NFGC (U.S.) and B149 (Canada). The minimum flue pipe diameter for conventional negative-draft venting using double-wall Type B vent is the vent size given in **Table M**.

NOTE: A vent adapter (field-supplied) must be used to connect Type B vent to the unit.

NOTE: When an existing category I appliance is removed or replaced, the original venting system may no longer be sized properly. Improperly-sized venting system can cause formation of condensate, leakage and spillage, etc.

The connection from the appliance vent to the stack must be as direct as possible and shall be the same diameter as, or larger than, the vent outlet. The horizontal breaching of a vent must have an upward slope of not less than 1/4 inch per linear foot from the heater to the vent terminal. The horizontal portions of the vent shall also be supported for the design and weight of the material employed to maintain clearances and to prevent physical damage or separation of joints. See **Table M** for Category I venting guidelines.

Model	Certified Venting Material	Vent Size	Vertical Venting Height ¹		Combustion Air Intake Pipe Material	Air Inlet Max. Length ²	
			Min. ft (m)	Max. ft (m)		10" ft (m)	12" ft (m)
992C	Category I ³ (Type B Equivalent)	10"	5 (1.52)	25 (7.62)	Galvanized Steel, PVC, ABS, CPVC	75 (22.86)	100 (30.48)
1262C		12"					
1532C		14"					
1802C		14"				40 (12.19)	75 (22.86)
2002C		16"					
2072C							
2342C							

¹ Vent lengths are based on a lateral length of 2 ft (61 cm). Refer to the latest edition of the NFGC for further details. When vertical height exceeds 25 ft (7.62 m), consult factory prior to installation.

² Subtract 10 ft (3.05 m) per elbow. Max. 3 elbows.

³ For Direct Vent applications, positive-pressure venting must be used.

Maximum combustion air duct length terminated at 100 equivalent ft (30.34 m).

Table M. Category I Vertical Venting

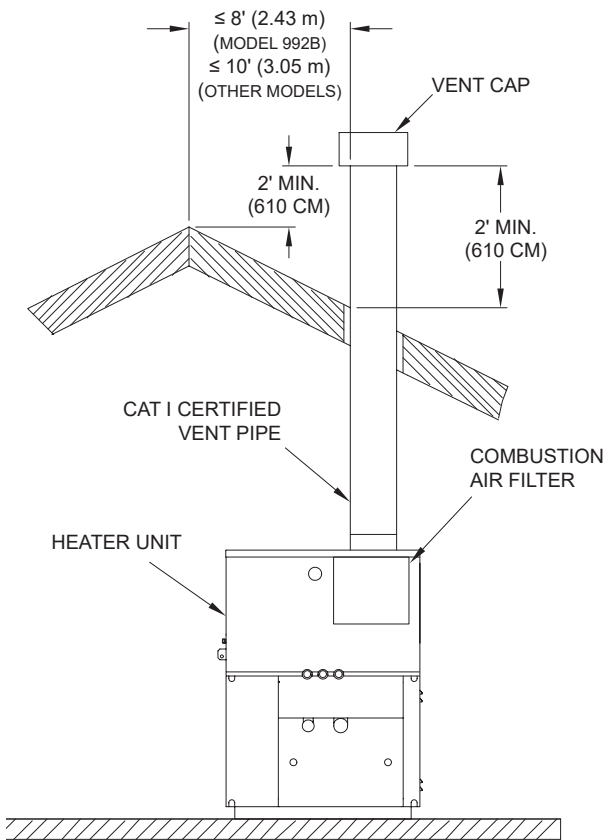

Figure 36. Vertical Venting (Category I)

Termination

The vent terminal should be vertical and should terminate outside the building at least 2 ft (61 cm) above the highest point of the roof that is within 8 ft (2.4 m). The vent cap should have a minimum clearance of 4 ft (1.2 m) horizontally from and in no case above or below (unless a 4 ft (1.2 m) horizontal distance is maintained) electric meters, gas meters, regulators and relief equipment. The distance of the vent terminal from adjacent public walkways, adjacent buildings, open windows and building openings must be consistent with the NFGC (U.S.) or B149 (Canada). Gas vents supported only by flashing and extended above the roof more than 5 ft (1.5 m) should be securely guyed or braced to withstand snow and wind loads.

CAUTION: A listed vent cap terminal, adequately sized, must be used to evacuate the flue products from the heaters.

Horizontal Through-the-Wall Venting (Category III)

Installation

These installations utilize the heater-mounted blower to vent the combustion products to the outdoors. Combustion air is taken from inside the room and the vent is installed

horizontally through the wall to the outdoors. Adequate combustion and ventilation air must be supplied to the equipment room in accordance with the NFGC (U.S.) or B149 (Canada).

The total length of the horizontal through-the-wall flue system should not exceed 70 equivalent ft (22.9 m) in length. If horizontal run exceeds 70 equivalent ft (22.9 m), an appropriately sized extractor must be used. Each elbow used is equal to 10 ft (1 m) of straight pipe. This will allow installation in one of the four following arrangements:

- 70' (21.3 m) of straight flue pipe
- 60' (18.3 m) of straight flue pipe and one elbow
- 50' (15.2 m) of straight flue pipe and two elbows
- 40' (12.2 m) of straight flue pipe and three elbows

The vent cap is not considered in the overall length of the venting system. The horizontal portions of the venting system shall be adequately supported to prevent sagging.

The vent must be installed to prevent flue gas leakage. Care must be taken during assembly to ensure that all joints are sealed properly and are airtight. The vent must be installed to prevent the potential accumulation of condensate in the vent pipes. It is required that:

1. The vent must be installed with a slight upward slope of not more than 1/4 inch per foot of horizontal run to the vent terminal.
2. The vent must be insulated through the length of the horizontal run.

For installations in extremely cold climate, it is required that:

1. The vent must be installed with a slight upward slope of not more than 1/4 inch per foot of horizontal run to the vent terminal. In this case, an approved condensate trap must be installed per applicable codes.
2. The vent must be insulated through the length of the horizontal run.

The vent and intake pipe material are certified to the following standards:

PVC-ANSI/ASTM D1785

CPVC ASTM-D2846

PPS (where applicable) - ULC-S636

Steel-certified for Cat IV or direct vent appliance venting.

Note: Please refer to Table N for model specific details.

Termination

For through-the-wall vent installations, the Raypak stainless steel vent termination (sales order option D-15) MUST be used and MUST be mounted on the exterior of the building. The D-15 cannot be installed in a well or below grade, and must be installed at least 1 ft (305 mm) above ground level and 1 ft (305 mm) above above normal snow levels.

⚠ WARNING: No substitutions of flue pipe or vent cap material are allowed. Such substitutions would jeopardize the safety and health of inhabitants.

CAUTION: Condensate is acidic and highly corrosive.

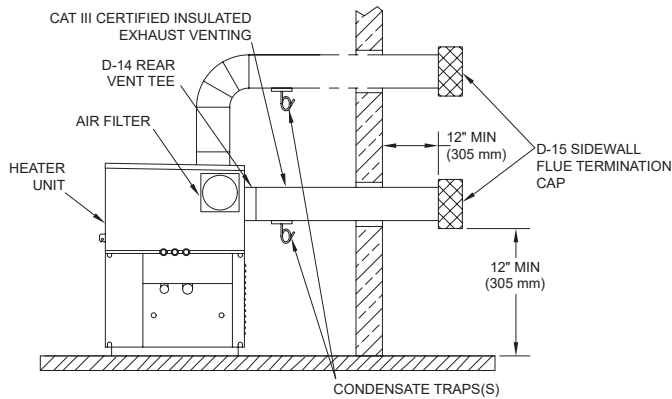

Figure 37. Horizontal Through-the-Wall Venting (Category III)

Use only the special gas vent pipes listed for use with Category III gas burning heaters, such as the stainless steel vents offered by Heat Fab Inc. (800-772-0739), Protech System, Inc. (800-766-3473), Z-Flex (800-654-5600) or American Metal Products (800-423-4270). Pipe joints must be positively sealed. Follow the vent manufacturer's installation instructions carefully.

Ducted Air - Horizontal Through-the-Wall

Installation

These installations utilize the heater-mounted blower to draw combustion air from outdoors and vent combustion products to the outdoors.

The total length of the through-the-wall flue cannot exceed 40 equivalent ft (12.2 m) in length for the flue outlet. Each elbow used is equal to 10 ft (1 m) of straight pipe. This will allow installation in one of the three following arrangements:

- 40' (12.2 m) of straight flue pipe
- 30' (9.1 m) of straight flue pipe and one elbow
- 20' (6.1 m) of straight flue pipe and two elbows

The total length of either air supply or vent pipe cannot exceed the distances listed in **Table N**. Each elbow used is equal to 10 ft (1 m) of straight pipe. This will allow installation in any arrangement that does not exceed the lengths shown in **Table N**.

The flue direct vent cap is not considered in the overall length of the venting system.

Care must be taken during assembly that all joints are sealed properly and are airtight.

The vent must be installed to prevent the potential accumulation of condensate in the vent pipes. It is required that:

1. The vent must be installed with a slight downward slope of not more than 1/4 inch per foot of horizontal run to the vent terminal.
2. The vent must be insulated through the length of the horizontal run.

For installations in extremely cold climate, it is required that:

1. The vent must be installed with a slight upward slope of not more than 1/4 inch per foot of horizontal run to the vent terminal. In this case, an approved condensate trap must be installed per applicable codes.
2. The intake vent must be insulated through the length of the horizontal run.

Units with ducted combustion air DO NOT meet the requirements for direct venting, unless they are equipped with internal ducting to fully isolate the combustion system from room air. The internal ducting is the TruSeal® option (Sales order option, D-21 if factory-installed or D-22 if field-installed). To meet direct-vent requirements, the combustion air ducting used must be a sealed-joint design. see 12.

Termination

The stainless steel sidewall vent termination MUST be furnished by the heater manufacturer in accordance with its listing (sales order option D-15).

The D-15 sidewall vent cap MUST be mounted on the exterior of the building. The D-15 cannot be installed in a well or below grade, and must be installed at least 1 ft (30.5 cm) above ground level and above normal snow levels.

⚠ WARNING: No substitutions of flue pipe or vent cap material are allowed. Such substitutions would jeopardize the safety and health of inhabitants.

CAUTION: Condensate is acidic and highly corrosive.

The D-15 vent cap MUST NOT be installed directly beneath any combustion air inlet within 36" (91 cm). This vertical spacing would allow the flue products from the D-15 to be pulled into the combustion air intake installed above.

This type of installation can cause non-warrantable problems with components and poor operation of the heater due to the recirculation of flue products. Multiple D-15 caps installed in the same horizontal plane must have a 4 ft (122 cm) clearance from the side of one vent cap to the side of the adjacent vent cap(s). Stacking the vent caps vertically eliminates the prospect of the exhaust plumes interfering with each other.

Combustion air supplied from outdoors must be free of particulate and chemical contaminants. To avoid a blocked flue condition, keep the vent cap clear of snow, ice, leaves, debris, etc.

Use only the special gas vent pipes listed for use with Category III gas burning heaters, such as the stainless steel vents offered by Heat Fab Inc. (800-772-0739), Protech System, Inc. (800-766-3473), Z-Flex (800-654-5600) or American Metal Products (800-423-4270). Pipe joints must be positively sealed. Follow carefully the vent manufacturer's installation instructions.

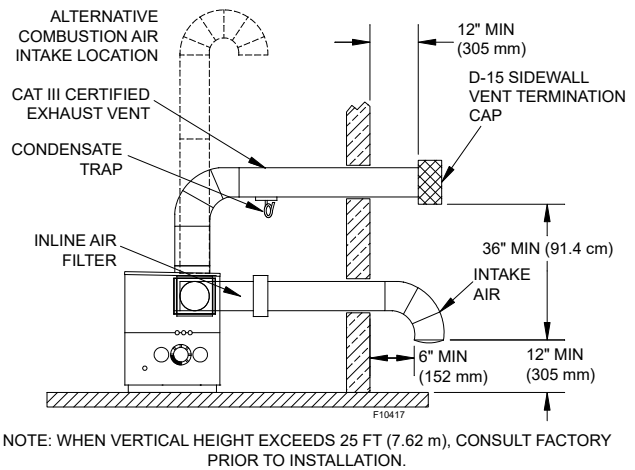

Figure 38. Ducted Air - Horizontal Through-the-Wall

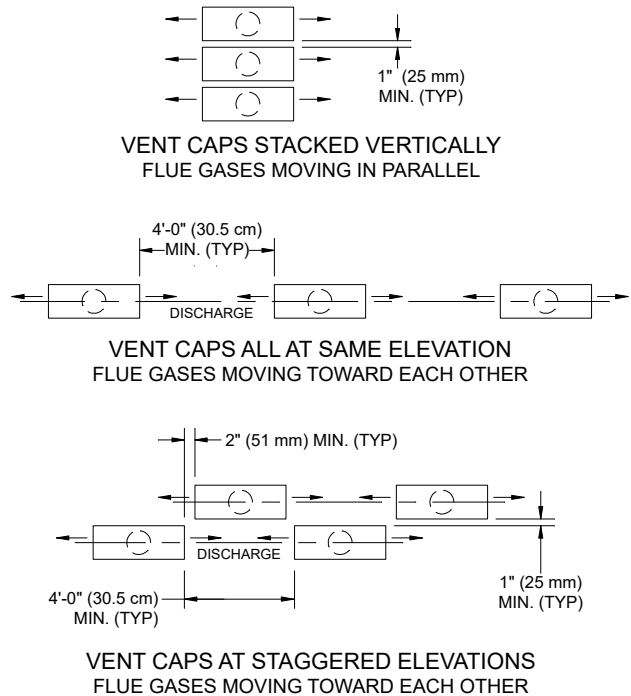

Figure 39. Vent Cap Configurations

Model No.	Certified Venting Material	Vent Size	Maximum Equivalent Vent Length* ft (m)	Combustion Air Intake Pipe Material	Air Inlet Max. Length ft (m)	
					6"	8"
992C	Category III	10"	70 (21.34) Room Air	Galvanized Steel, PVC, ABS, CPVC	75 (22.86)	100 (30.48)
1262C		12"				
1532C		14"	40 (12.19) Ducted Combustion Air		40 (12.19)	75 (22.86)
1802C						
2002C						
2072C						
2342C	16"					

* Subtract 10 ft (3 m) per elbow. Max. 3 elbows.

Maximum combustion air duct length terminated at 100 equivalent ft (30.38 m).

Table N. Category III Horizontal and Ducted Air

Ducted Air - Vertical

Installation

These installations utilize the heater-mounted blower to draw combustion air from outdoors and force the heated flue products through the vent pipe under positive pressure. The vent material must be in accordance with the above instructions for vent materials. Vent material must be listed by a nationally-recognized test agency.

The connection from the appliance flue to the stack must be as direct as possible and should be the same size or larger than the vent outlet.

Unsealed flue pipe may allow flue products to enter a room containing contaminated air, creating a hazard. Raypak does not support the use of unsealed flue pipe such as B-Vent in direct vent applications.

Use only the special gas vent pipes listed for use with Category III gas burning heaters, such as the stainless steel vents offered by Heat Fab Inc. (800-772-0739), Protech System, Inc. (800-766-3473), Z-Flex (800-654-5600) or American Metal Products (800-423-4270). Pipe joints must be positively sealed. Follow carefully the vent manufacturer's installation instructions.

Units with ducted combustion air DO NOT meet the requirements for direct venting, unless they are equipped with internal ducting to fully isolate the combustion system from room air. The internal ducting is the TruSeal® option (Sales order option, D-21 if factory-installed or D-22 if field-installed). To meet direct-vent requirements, the combustion air ducting used must be a sealed-joint design. see 12.

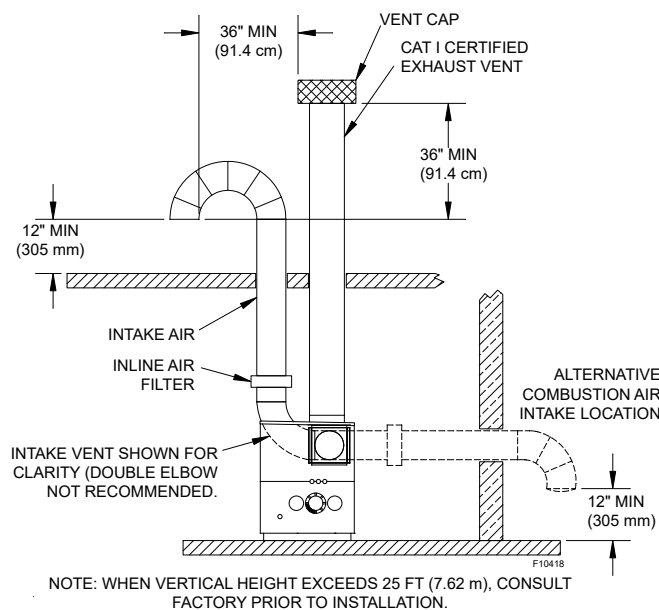

Figure 40. Ducted Air - Vertical

See **Table M** for Category I venting guidelines.

It is recommended that in colder climates, the intake vent be insulated.

Termination

The flue terminal should be vertical and should terminate outside the building at least 2 ft (61 cm) above the highest point of the roof within 8 ft. (2.44 m) for all other models. The vent cap should have a minimum clearance of 4 ft (1.22 m) horizontally from and in no case above or below (unless a 4 ft (1.22 m) horizontal distance is maintained) electric meters, gas meters, regulators and relief equipment. The distance of the vent terminal from adjacent public walkways, adjacent buildings, open windows and building openings must be consistent with the NFGC (U.S.) or B149 (Canada).

Flues supported only by flashing and extended above the roof more than 5 ft (1.5 m) should be securely guyed or braced to withstand snow and wind loads.

The air inlet opening MUST be installed 1 ft (305 mm) above the roof line or above normal snow levels that might obstruct combustion air flow. This dimension is critical to the correct operation of the heater and venting system and reduces the chance of blockage from snow. The vent cap must have a minimum 3 ft (91 cm) vertical clearance from the air inlet opening.

Common Venting System

Manifolds that connect more than one heater to a common chimney must be sized to handle the combined load. Consult available guides for proper sizing of the manifold and the chimney. At no time should the area of the common vent be less than the area of the largest heater exhaust outlet.

Common venting systems may be too large once an existing unit is removed. At the time of removal of an existing appliance, the following steps must be followed with each appliance remaining connected to the common venting system placed in operation, while the other appliances remaining connected to the common venting system are not in operation.

WARNING: Vent connectors serving appliances vented by natural draft shall not be connected into any portion of mechanical draft systems operating under a positive pressure.

CAUTION: Vent connectors for natural draft venting systems must be Type B or better.

1. Seal any unused opening in the common venting system.
2. Visually inspect the venting system for proper size and horizontal pitch and verify there is no blockage, restriction, leakage, corrosion or other unsafe condition.
3. Insofar as is practical, close all building doors and windows and all doors between the space in which the appliances remaining connected to the common venting system are located and other spaces of the

building. Turn on clothes dryers and any appliance not connected to the common vent system. Turn on any exhaust fans, such as range hoods and bathroom exhausts, at maximum speed. Do not operate summer exhaust fan. Close fireplace dampers.

- Place in operation the appliances being inspected. Follow the manufacturer's instructions for lighting each appliance. Adjust thermostat so appliance will operate continuously.
- Check the pressure at a pressure tap located 12" (30.5 cm) above the bottom joint of the first vertical vent pipe. Pressure should be anywhere between -0.01 and -0.08 in. WC.
- After it has been determined that each appliance remaining connected to the common venting system properly vents when tested as outlined above, return doors, windows, exhaust fans, fireplace dampers and other gas burning appliances to their previous conditions of use.
- Any improper operation of the common venting system should be corrected so that the installation conforms with the NFGC (U.S.) or B149 (Canada). When re-sizing any portion of the common venting system, the common venting system should be re-sized to approach the minimum size as determined using the appropriate tables in the NFGC (U.S.) or B149 (Canada).
- Common venting under CAT III (positive vent pressure) conditions is not supported.

Outdoor Installation

Outdoor models are self-venting when installed with the optional factory-supplied outdoor vent kit and require no additional vent piping. A special vent cap, flow switch cover and air intake hood are provided in accordance with CSA requirements, which must be installed directly on the heater. Correct clearances can be found earlier in this section.

Care must be taken when locating the heater outdoors, because the flue gases discharged from the vent cap can condense as they leave the cap. Improper location can result in damage to adjacent structures or building finish. For maximum efficiency and safety, the following precautions must be observed:

- Outdoor models must be installed outdoors and must use the outdoor vent cap, flow switch cover and air intake hood available from the manufacturer (sales order option D-11).
- Periodically check venting system. The heater's venting areas must never be obstructed in any way and minimum clearances must be observed to prevent restriction of combustion and ventilation air. Keep area clear and free of combustible and flammable materials.
- Do not locate adjacent to any window, door walkway,

or gravity air intake. The vent must be located a minimum of 4 ft (1.2 m) horizontally from such areas.

- Install above grade level and above normal snow levels.
- Vent terminal must be at least 3 ft (91 cm) above any forced air inlet located within 10 ft (1 m).
- Adjacent brick or masonry surfaces must be protected with a rust-resistant sheet metal plate.

NOTE: Condensate can freeze on the vent cap. Frozen condensate on the vent cap can result in a blocked flue condition.

NOTE: The vent cap, flow switch cover and air intake hood must be furnished by the heater manufacturer in accordance with its listing (sales order option D-11).

Sequence of Operation

Models 992C-1262C

- Upon initial application of 24VAC power, the PIM resets with all outputs in the "OFF" state.
- The PIM and VERSA IC® Control perform a processor and memory self-test to ensure proper operation.
- The PIM confirms the presence of a valid ID Card which matches the configuration stored in memory at the factory. If a valid ID Card is NOT present, the PIM generates a diagnostic fault and will shut down waiting for this fault to be addressed.
- The PIM reads the DIP switch settings and configures itself for the desired operation.
- The PIM scans the Ft_bus communications for the VERSA IC® Control and if found, system operation is controlled by the VERSA IC® Control.
- Non-volatile memory is checked for any active lockout conditions. If any exist, they must be addressed before the PIM will allow a new trial for ignition to start.
- The PIM continually monitors the flame status to ensure that no flame is present during standby. If an erroneous flame is detected, the PIM generates a False Flame error fault.
- A Call-for-heat is initiated by the presence of any one or more of the 4 sources below:
 - A heat demand (contact closure) on the TH field wiring terminals.
 - A voltage greater than 0.5 VDC on the analog 0-10 VDC EMS signal input.
 - A heat demand present on the DHW field wiring terminals.
 - A heat demand from the VERSA IC® Control based on the DHW sensor temperature.

9. The PIM initiates a trial for ignition counter to the programmed number of trials for ignition (1 or multiple) and proceeds to Pump Purge mode.
 10. The VERSA IC® Control will turn on the system, boiler and/or DHW pump as necessary to address the call-for-heat. This is dependent on the Mode of operation selected. The pumps will proceed through their purge period before the control will move into a Trial for Ignition (TFI). For systems with CWP enabled, the MIX output is sent to the MIX MIN % value.
 11. The VERSA Control Board and PIM check the safety circuit and will stop from going into a trial for ignition if any of the safety devices is in an error/fault condition.
 12. If no fault condition is found, the air pressure switch (if present) is verified to be in the open position before the blower is energized.
 13. The blower(s) are energized.
 14. The air pressure switches are verified closed within 60 seconds to prove air flow.
 15. Once the air pressure switches close, the blower proceeds to pre-purge for the specified period.
 16. The voltage level of the 24VAC supply input is confirmed to be above 18.0VAC – if not, a Low Voltage fault will be recorded and the heater will go into a soft lockout condition until the voltage rises above 18.0VAC consistently.
 17. If all checks have passed, the system proceeds to ignition.
 18. The PIM re-initializes the ignition counter to the configured number of trials (typically 1 or 3).
 19. The Hi Limit sensor is confirmed to read below the Hi Limit setpoint.
 20. The gas valve relay contacts are verified open – if closed, a fault code will be issued and the heater will post-purge and go into a hard lockout condition.
 21. The Hi Delta units are equipped with a Hot Surface Igniter:
 - a. The control turns on the HSI and the HSI proving current is verified to be above the configured value.
 - b. The configured heat-up delay takes place to allow the HSI element to reach ignition temperature.
 - c. The gas valve output is energized for the trial-for-ignition time to light the burner.
 - d. The HSI is de-energized during the last second of the trial-for-ignition period to sense for the burner flame.
 - e. The flame sense is checked for successful lighting of the burner. If a valid flame is detected, the main gas valve, operating pumps and blower relay remain energized and the PIM proceeds to the Heating mode.
 - f. For systems with CWP enabled, the MIX output is released to its control point based on distance from Inlet temperature target.
 - g. When power is sent to the first gas valve it is also used to energize the stage module, which also receives a proportional signal generated by the PIM that will stage the firing rate based on the calculated heat demand.
 - h. The proportional signal will determine the exact time when the 2nd Stage relay is activated. At the moment of activation a Time Delay Relay 1 (TDR-1) will be energized, which starts a 5-second countdown.
 - i. After the 5-second countdown TDR-1 energizes Gas Valve 2 and provides power on one side of the Stage 3 relay dry contact (NO).
 - j. The proportional signal will determine the exact time when the 3rd Stage relay is activated. At the moment of activation a Time Delay Relay 2 (TDR-2) will be energized, which starts a 5-second countdown.
 - k. After the 5-second countdown TDR-2 energizes Gas Valve 3.
 - l. (1262C) When Gas Valve 3 activates, power is also provided on one side of the Stage 4 relay dry contact (NO).
 - m. (1262C) The proportional signal will determine the exact time when the 4th Stage relay is activated, at the moment of activation a Time Delay Relay 3 (TDR-3) will be energized, which starts a 5-second countdown.
 - n. (1262C) After the 5-second countdown TDR-3 energizes Gas Valve 4.
 22. If flame is not detected during the trial-for-ignition period, the gas valve output is disabled immediately and the blower goes to post-purge.
 23. On single trial-for-ignition models, the PIM enters ignition lockout and the LED on the PIM indicates the fault code for ignition lockout. The VERSA IC® Display should also state Ignition Lockout.
- On multi-trial-for-ignition models, the control goes through an interpurge delay before additional ignition attempts are started. If no flame is detected after the final trial-for-ignition, the PIM enters ignition lockout and the LED on the PIM indicates the fault code for ignition lockout. The VERSA IC® Display should also state Ignition Lockout.

Models 1532C-2342C

1. Upon initial application of 24VAC power, the PIM resets with all outputs in the “OFF” state.
2. The Primary PIM and VERSA IC® Control perform a processor and memory self-test to ensure proper operation.

3. The Primary PIM and Secondary PIM confirm the presence of a valid ID Card which matches the configuration stored in memory at the factory. If valid ID Cards are NOT present, the individual PIM generates a diagnostic fault and will shut down waiting for this fault to be addressed.
4. The Primary PIM reads the DIP switch settings and configures itself for the desired operation.
5. The Primary PIM scans the Ft_bus communications for the VERSA IC® Control and if found, system operation is controlled by the VERSA IC® Control. Additionally the Primary PIM, once confirmed the Dual PIM configuration by the ID card, scans for the Secondary PIM. If not found, the system generates a diagnostic fault and will proceed operation with the available capacity.
6. Non-volatile memory is checked for any active lockout conditions. If any exist, they must be addressed before the Primary PIM will allow a new trial for ignition to start.
7. The Primary PIM and Secondary PIM continually monitor the flame status to ensure that no flame is present during standby. If an erroneous flame is detected, the individual PIM generates a False Flame error fault.
8. A Call-for-heat is initiated by the presence of any one or more of the 4 sources below:
 - a. A heat demand (contact closure) on the TH field wiring terminals.
 - b. A voltage greater than 0.5 VDC on the analog 0-10 VDC EMS signal input.
 - c. A heat demand present on the DHW field wiring terminals.
 - d. A heat demand from the VERSA IC® control based on the DHW sensor temperature.
9. The Primary PIM initiates a trial for ignition counter to the programmed number of trials for ignition (1 or multiple) and proceeds to Pump Purge mode.
10. The VERSA IC® Control will turn on the system, boiler and/or DHW pump as necessary to address the call-for-heat. This is dependent on the Mode of operation selected. The pumps will proceed through their purge period before the control will move into a Trial for Ignition (TFI). For systems with CWP enabled, the MIX output is sent to the MIX MIN % value.
11. The VERSA Control Board and PIM check the safety circuit and will stop from going into a trial for ignition if any of the safety devices is in an error/fault condition.
12. If no fault condition is found, the air pressure switch (if present) is verified to be in the open position before the blower is energized.
13. The blower(s) are energized.
14. The air pressure switch is verified to close within 60 seconds to prove air flow.
15. Once the air pressure switch closes, the blowers proceed to pre-purge for the specified duration.
16. At this point all safeties have been verified and Primary PIM activates the Interlock Signal, which indicates to the Secondary PIM that it is ready to attempt an ignition sequence whenever the VERSA Control Board indicates.
17. The voltage level of the 24VAC supply input is confirmed to be above 18.0VAC – if not, a Low Voltage fault will be recorded and the heater will go into a soft lockout condition until the voltage rises above 18.0VAC consistently.
18. If all checks have passed, the system proceeds to ignition.
19. Either Primary or Secondary PIM (depending on the rotation sequence) re-initializes the ignition counter to the configured number of trials (typically 1 or 3). (For the sequence of operation description it is assumed that the Primary PIM is leading the rotation sequence).
20. The Hi Limit sensor is confirmed to read below the Hi Limit setpoint.
21. The gas valve relay contacts are verified open – if closed, a fault code will be issued and the heater will post-purge and go into a hard lockout condition.
22. The Hi Delta units are equipped with a Hot Surface Igniter:
 - a. The Primary PIM control turns on the HSI and the HSI proving current is verified to be above the configured value.
 - b. The configured heat-up delay takes place to allow the HSI element to reach ignition temperature.
 - c. The “Gas Valve 1” output (from Primary PIM) is energized for the trial for-ignition time to light the burner.
 - d. The HSI is de-energized during the last second of the trial-for-ignition period to sense for the burner flame.
 - e. The flame sense is checked for successful lighting of the burner. If a valid flame is detected, the main gas valve, operating pumps and blower relay remain energized and the Primary PIM proceeds to the Heating mode.
 - f. For systems with CWP enabled, the MIX output is released to its control point based on distance from Inlet temperature target.
 - g. (2002C-2342C) when power is sent from Primary PIM to main gas valve (1) it is also sent to Time Delay Relay 1 (TDR-1), which starts a 5-second countdown.

- h. (2002C-2342C) after the 5-second countdown TDR-1 energizes Gas Valve 1A.
 - i. The second stage will be triggered by the Primary PIM using the second relay build into the Primary PIM hardware (J14- 2, 5).
 - j. When heat demand is reached the Primary PIM will be required by the VERSA Control Board to activate Gas Valve 2.
 - k. At this point if the Interlock remains activated and heat demand is still present, the Secondary PIM is called to continue the ramp up process.
 - l. The Secondary PIM control turns on the HSI and the HSI proving current is verified to be above the configured value.
 - m. The configured heat-up delay takes place to allow the HSI element to reach ignition temperature.
 - n. The "Gas Valve 3" output (from Secondary PIM) is energized for the trial-for-ignition time to light the burner.
 - o. The HSI is de-energized during the last second of the trial-for-ignition period to sense for the burner flame.
 - p. The flame sense is checked for successful lighting of the burner. If a valid flame is detected, the main gas valve, operating pumps and blower relay remain energized.
 - q. The Fourth Stage will be triggered by the Secondary PIM using the second relay build into the Secondary PIM hardware (J14- 2, 5).
 - r. When heat demand is reached Secondary PIM will be required by the VERSA Control Board to activate Gas Valve 4.
23. If flame is not detected during the trial-for-ignition period by Primary or Secondary PIM, only the correspondent gas valves outputs are disabled immediately at the individual PIM with the ignition failure.
24. The system will command the blower to go into a post-purge if the no secured stages are active and monitored by the remaining PIM. If Heat is still required the remaining healthy PIM will take over the demand.
25. If any safety is compromised the Primary PIM will terminate the Interlock signal as a hardwire notification of the failure. The lack of Interlock signal will terminate any active stage monitored by the Secondary PIM.
26. As a safety redundancy Primary PIM will communicate through the FT_BUS to the Secondary PIM to terminate all active stages.
27. On single trial-for-ignition models, the PIM enters ignition lockout and the LED on the PIM indicates the fault code for ignition lockout. The VERSA IC® Display should also state Ignition Lockout.
- On multi-trial-for-ignition models, the control goes through an interpurge delay before additional ignition attempts are started. If no flame is detected after the final trial-for-ignition, the PIM enters ignition lockout and the LED on the PIM indicates the fault code for ignition lockout. The VERSA IC® Display should also state Ignition Lockout.

Freeze Protection

To enable freeze protection, DIP switch position 7 (on the PIM) must be turned ON (UP position). This is the default position.

If the water temperature drops below 45°F (7.2°C) on the Outlet or Inlet sensors, the Boiler pump is enabled. The pump is turned off when both the Inlet and Outlet temperatures rise above 50°F (10°C).

If either the Outlet or Inlet temperature drops below 38°F (3.3°C), the VERSA starts the burner at the minimum firing rate. The burner cycle will terminate when both the Inlet and Outlet temperatures rise above 42°F (5.5°C).

Controls

⚠ WARNING: Installation, adjustment and service of heater controls, including timing of various operating functions, must be performed by a qualified installer, service agency or the gas supplier. Failure to do so may result in control damage, heater malfunction, property damage, personal injury, or death.

⚠ WARNING: Turn off the power to the heater before installation, adjustment or service of any heater controls. Failure to do so may result in board damage, heater malfunction, property damage, personal injury, or death.

⚠ CAUTION: This appliance has provisions to be connected to more than one supply source. To reduce the risk of electric shock, disconnect all such connections before servicing.

⚠ CAUTION: Risk of electric shock: More than one disconnect switch may be required to de-energize the equipment before servicing.

Ignition Control Functions

When there is a call for heat, and all safeties are closed, then the combustion air blower starts to purge air from the combustion chamber. After the pre-purge, the igniter is energized. The standard ignition module will lock-out after failing to light 3 times during a call for heat. To reset the lock-out, press and release the RESET button located on the user interface. The control will automatically reset after 1 hour. When in lock-out the control will run the blower through a post-purge cycle.

The single-try ignition module (part of the CSD-1 option) will attempt to light only one time before lock-out occurs. To reset the lock-out, press and release the RESET button located on the user interface.

Turning off the power to the heater WILL NOT reset the single-try ignition module.

High Limit—Manual-Reset

This heater is equipped with a fixed-setting manual-reset high limit temperature device as standard. It may also have an additional optional adjustable manual-reset high-temperature device.

Standard

The fixed setting manual-reset high limit is built into the PIM, it utilizes a dual-element sensor located on the outlet (see **Figure 41**). To reset a high limit lock-out, press and release the RESET button located on the user interface.

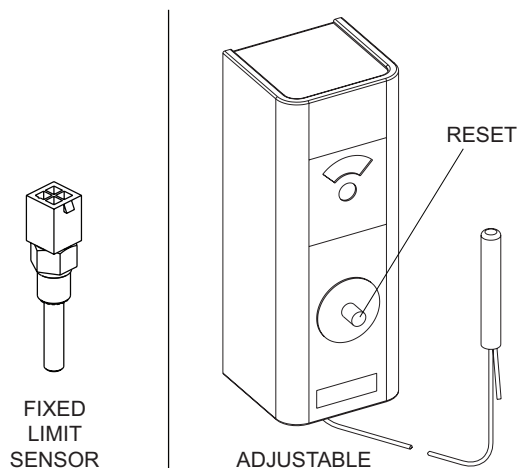

Figure 41. High Limit (Manual-Reset)

High Limit—Auto-Reset (Optional)

This heater may be equipped with an optional adjustable auto-reset high limit temperature device.

Adjust the setting to approx. 20°F (11°C) above desired outlet temperature.

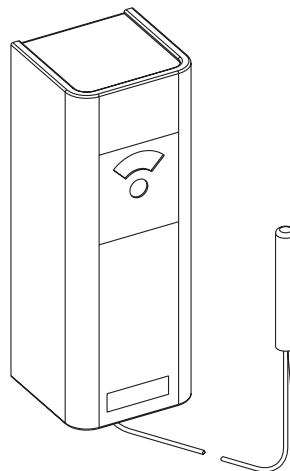

Figure 42. Adjustable High Limit (Auto-Reset)

Flow Switch

The flow switch is provided as standard and is factory mounted and wired. The switch shuts off heater in case of pump failure or low water flow.

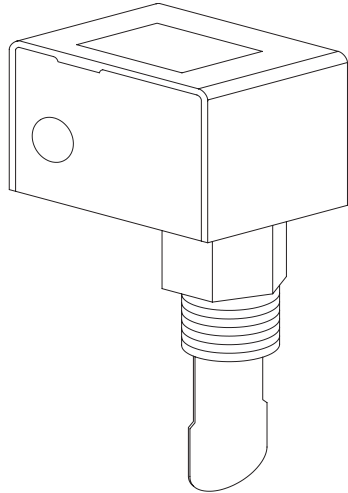

Figure 43. Flow Switch

Low Water Cut-Off (Optional)

The low water cut-off (Sales option F-10) automatically shuts down the burner whenever water level drops below the level of the sensing probe. A 5-second time delay prevents premature lockout due to temporary conditions such as power fluctuations or air pockets.

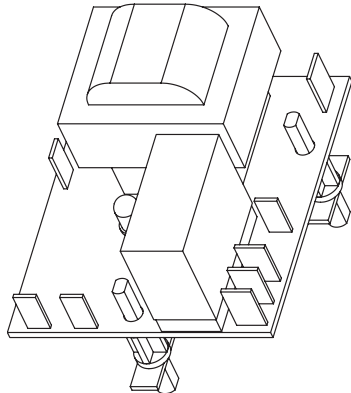

Figure 44. Low Water Cut-Off

High and Low Gas Pressure Switches

The low gas pressure switch (standard) connection mounts upstream of the gas valve to ensure that sufficient gas pressure is present for proper regulator performance. The low gas pressure switch automatically shuts down the heater if gas supply drops below the factory setting of 5.0 in. WC for natural gas, and 10.0 in. WC for propane gas.

The high gas pressure switch (Sales option S-2) connection mounts downstream of the stage-1 gas valve. If the gas pressure regulator fails, the high gas pressure switch automatically shuts down the burner. The high gas pressure switch automatically shuts down the heater if gas manifold pressure rises above the setting of 5.0 in. WC for natural gas, and 11.5 in. WC for propane gas.

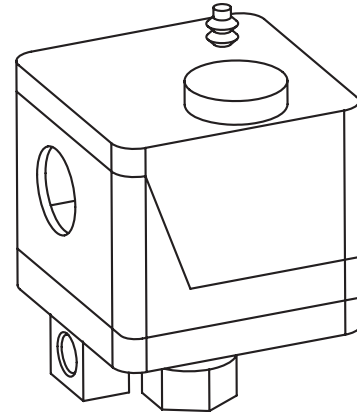

Figure 45. High/Low Gas Pressure Switch

Air Pressure Switch

This heater is equipped with a one or more air pressure switches to prove blower operation prior to ignition. This switches are located on the blower housing.

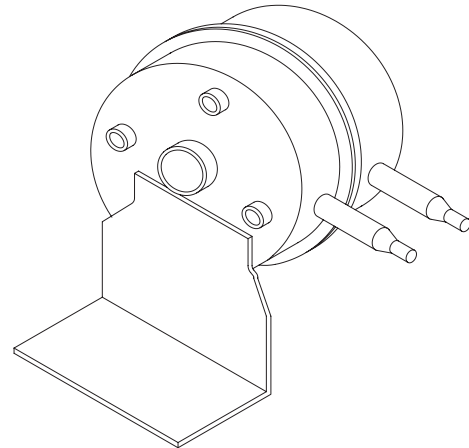

Figure 46. Air Pressure Switch

Blocked Vent Switch

This heater is equipped with a blocked vent pressure switch to prevent the operation of the heater when too much of the vent is blocked. This switch is located inside the left upper cabinet adjacent the control box.

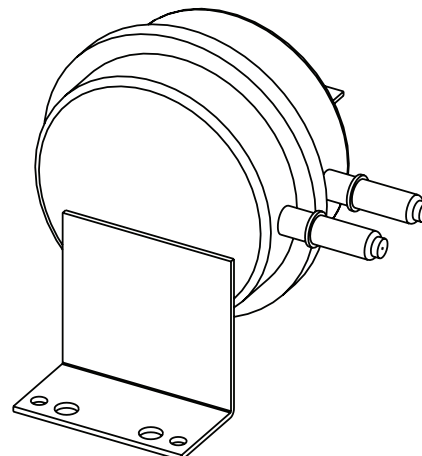

Figure 47. Blocked Vent Switch

User Interface

The user interface consists of several Menu options. Press the MENU button to scroll through the different menus in the interface. Press the ITEM button to scroll through available items within a selected menu. And, the UP and DOWN buttons allow for setting changes to items in the ADJUST menu. Refer to **Figure 48** for display and key locations.

For detailed descriptions of the various screens, consult the VERSA IC® manual 241493.

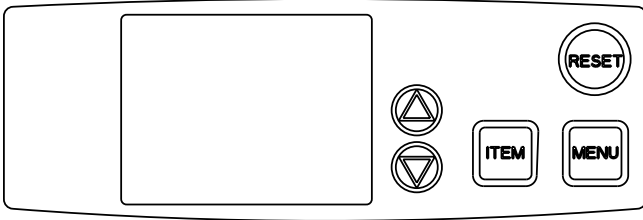

Figure 48. User Interface

Adjusting the Hi Delta Setpoint

Use the MENU key to scroll to the SETUP/ADJUST menu, then use the ITEM key to scroll to the SETPOINT item. Adjust the Setpoint using the UP and DOWN arrow keys. Minimum setpoint for H, WH and P models is 50°F (10°C), Maximum setpoint for H models is 220°F (104°C), for WH models 160°F (71°C). Maximum setpoint for P models is 106°F (41°C).

View Menu

The VIEW menu is the default menu. It displays sensor temperatures, the modulation rate of the blower, heater cascade status, pump operation and CFH (Call For Heat) information. Some of the items displayed are mode specific and are only observable when its corresponding mode is active.

Menu - Initial Adjustment

To change settings use the MENU key to scroll to the SETUP/ADJUST menu. The ADJUST menu allows the installer to make adjustments to items shown in **Table P**.

Refer to the VERSA IC® manual (241493) for detailed setup instructions.

View Menu

The “View” icon is turned on. BOILER and 1 segment are turned on if BOILER 2, 3 or 4 are set to ON.

Item	Display Range	When is it Displayed	Description
OUTDOOR	---, -76°F to 149°F (-60°C to 65°C)	MASTER PIM Identity is H TARGET = RSET	Outdoor air temperature, the number field displays “--- -” if OUTDOOR sensor has a fault.
TARGET	---, -22°F to 266°F (-30°C to 130°C)	MASTER MODBUS RATE EMS RATE	Current target water temperature, the number field displays “----” when there is no current target.
POOL	“----”, -22°F to 266°F (-30°C to 130°C)	PIM Identity is P	Current pool temperature, the number field displays “----” if the pool sensor fails.
TANK	----, -22°F to 266°F (-30°C to 130°C)	PIM Identity is WH	Current system supply temperature, the number field displays “----” if Tank sensor fails.
SUPPLY	---, -22°F to 266°F (-30°C to 130°C)	MASTER	Current system supply temperature, the number field displays “----” if the SUPPLY
IND SUPPLY	---, -22°F to 266°F (-30°C to 130°C)	PIM Identity is H MODE = 3	Current temperature being supplied to the indirect, the number field displays “----” if the indirect DHW sensor fails.
Boil OUTLET	---, -22°F to 266°F (-30°C to 130°C)	Always	Current boiler outlet temperature as communicated from the PIM, the number field displays “----”
Boil INLET	---, -22°F to 266°F (-30°C to 130°C)	Always	Current boiler outlet temperature as communicated from the PIM, the number field displays “----” if the outlet sensor fails.
Boil ΔT	0 to 252°F (-18°C to 130°C)	Always	Current boiler inlet temperature as communicated from the PIM, the number field displays “----” if the inlet and/or outlet sensor fails.
DHW Supply	---, -22°F to 266°F (-30°C to 122°C)	MASTER PIM Identity is H MODE = 2 OR 3 DHW SENSOR = ON	Current Indirect DHW Supply temperature, the number field displays “----” if the DHW sensor has a fault.
Boiler 1	IDLE, POST, PREP, STG 1, 2, 3, 4	MASTER	Shows the operation status of master boiler.
Boiler 2, 3, 4...	IDLE, POST, PREP, STG 1, 2, 3, 4	MASTER	Shows the operation status of all boilers in cascade.

Table O. View Menu

Item	Application	Range	Description	Default
TARGET	H MODE 1, 2, 3	RSET <> SETP	RSET = Outdoor Reset, SETP =Setpoint.	SETP
TANK SETP	WH	OFF, 50°F to 160°F (10°C to 71°C)	Tank setpoint temperature.	125°F (52°C)
TANK DIFF	WH	2°F to 10°F (1°C to 6°C)	Tank differential temperature.	3
POOL SETP	P	50°F to 104°F, 106°F (10°C to 40°C, 41°C)	Pool setpoint temperature.	80°F (27°C)
POOL DIFF	P	1°F to 5°F (1°C to 3°C)	Pool differential temperature.	2°F (1°C)
POOL MAX	P	110°F to 120°F (43°C to 49°C)	Max supply temperature to pool (Hold UP & DOWN for arrow adjustment.)	110°F (43°C)
MODE	H MODE 1, 2, 3	1,2,3	Piping and application configuration.	1
SETPOINT	H MODE 1, 2, 3	50°F to 220°F (10°C to 104°C)	Boiler target temperature while a heat demand is present for setpoint operation.	180°F (82°C)
OUT START	H MODE 1, 2, 3	35°F to 85°F (2°C to 29°C)	Outdoor starting temperature - outdoor reset.	70°F (21°C)
OUT DESIGN	H MODE 1, 2, 3	-60°F to 45°F (-51°C to 7°C)	Outdoor design temperature - outdoor reset.	10°F (-12°C)
Boil START	H MODE 1, 2, 3	35°F to 150°F (2°C to 65°C)	Starting boiler target temperature when the outdoor temperature is at outdoor start outdoor reset.	70°F (21°C)
Boil DESIGN	H MODE 1, 2, 3	70°F to 200°F (21°C to 93°C)	Design boiler target temperature when the outdoor temperature is at outdoor design outdoor reset.	180°F (82°C)
TARGET MAX	H MODE 1, 2, 3	100°F (38°C) to PIM value*	Maximum target system temperature.	220°F (104°C)
TARGET MIN	H MODE 1, 2, 3	OFF, 50°F to 190°F (10°C to 88°C)	Minimum target system temperature.	50°F (10°C)
TARGET DIFF	H MODE 1, 2, 3	2°F to 42°F (1°C to 6°C)	Differential for target system temperature.	10°F (-12°C)
IND SENSOR	H MODE 1, 2, 3	OFF <> ON	Selects whether a DHW sensor is used for indirect DHW tank.	OFF
IND SETP	H MODE 2, 3	OFF, 50°F to 180°F (10°C to 82°C)	Target Indirect DHW temperature (IND Sensor = ON, to enable this setting).	140°F (60°C)
DHW DIFF	H MODE 2, 3	2°F to 10°F (1°C to 6°C)	Differential for the target indirect DHW tank temperature, requires IND Sensor = ON.	6°F (-14°C)
CASCADE TYPE	Cascade Master Only	SEQ, PAR	Cascade operation type.	SEQ
CASCADE DELAY	Cascade Master Only	AUTO<> 0:10...10:00	Cascade Interstage delay before calling next boiler.	AUTO
CASCADE ALARM	Cascade Master Only	ON <> OFF	Cascade Alarm to all units in case of any unit presents alarm.	ON
IND SUPPLY	H MODE 2, 3	OFF, 50°F (10°C) to PIM value*	Target boiler temperature for the DHW heat exchanger during indirect DHW operation, requires IND Sensor = OFF.	180°F (82°C)
DHW PRIORITY	H MODE 2	OFF <> ON	Selects whether or not Indirect DHW priority is active during indirect DHW operation.	OFF
PRI OVR	H MODE 2, 3	Au, 0:10hr to 2:00hr	Sets the length of the indirect DHW priority override time.	1:00hr
SYS PURGE	All	OFF, 0:20min to 20:00min	Sets the length of the system pump post purge.	20 seconds
MIX TYPE	H/WH/P MIX	H (BOIL <> PLNT) WH (1 <> 2)	Selects the type of control depending on pipe configuration for CWP.	H BOIL WH 2
MIX TARGET	H/WH/P MIX	50°F to 140°F (10°C to 60°C)	Inlet Target temperature.	120°F (49°C)
MIX LOCK	H/WH/P MIX	ON <> OFF	The equipment will trigger a warning when "MIX Target" is not reached within 7 minutes. MIX LOCK = ON; Alarm and lockout, MIX LOCK = OFF; Alarm only.	OFF
MIX TRIM	H/WH/P MIX	-5°F to 5°F (-21°C to -15°C)	This adjustment is for various types and sizes of units as well as various actuator motor speeds and types supplied by Raypak.	0
MIX SPEED	H/WH/P MIX	FAST <> MED <> SLOW	This setting defines speed of response.	MED
MIX INV	H/WH/P MIX	ON <> OFF	This option is related to the use of spring return actuators with a proportional valve.	OFF
WWSD	H MODE 1, 2, 3	40°F to 100°F (4°C to 38°C)	The system warm weather shutdown temperature outdoor reset, requires TARGET = RSET.	70°F (21°C)
UNITS	All	deg F <> deg C	Show units using icons in display.	deg F
MODBUS	All	OFF <> MNTR <> TEMP <> RATE	ModBus Operating Mode: Off, Monitor, Temp Control, Rate Control.	OFF
ADDRESS	All	1 to 247	ModBus slave address.	1
DATA TYPE	All	RTU <> ASCI	Modbus data type.	RTU
BAUD RATE	All	2400 <> 9600 <> 19K2 <> 57K6 <> 115K		19K2
PARITY	All	NONE <> EVEN <> ODD		EVEN

* Fixed values based on ID Card.

Table P. Setup/Adjust Menu

Boiler Menu

The Boiler View displays various items regarding ignition, temperature monitoring, and modulation rates. As well as software and hardware information.

Item	Application	Description
BOILER 1	ALL	Enables Boiler for operation.
BOILER 2	CASCADE	Enables Ft_bus Boiler for cascade operation.
BOILER 3	CASCADE	Enables Ft_bus Boiler for cascade operation.
BOILER 4	CASCADE	Enables Ft_bus Boiler for cascade operation.
CASCADE	TN-BUS Cascade Follower	Set Cascade ID for TN-bus follower, see VERSA IC [®] manual 241493.
IGNITION (IGNITION 1/2, models 1532-2342)	ALL	IDLE=no CFH; PREP=pre-purge or inter-purge between trials for ignition; IGN=trial for ignition; BURN=burner operating; POST=post purge; HARD=a hard lockout fault has occurred requiring manual high limit); and SOFT=a soft lockout fault has occurred which interrupts the manual high limit). The CFH will resume after the soft lockout fault has been corrected and a 15 min. waiting period has expired.
VENT WALL	Not Available	Not Available.
LIMIT TEMP	ALL	Current Outlet -Limit temperature.
EMS VDC	ALL	Current EMS signal in Volts DC.
FIRE RATE	ALL	PIM firing rate.
OUTLET MAX	H Mode 1, 2, 3	Defines Max Outlet temperature offset above Target Setpoint (Press and hold up and down arrows for 3 seconds to enable adjustment), see VERSA IC [®] manual 241493.
OPERATOR	ALL	Operator Potentiometer setting on PIM.
DIFF	ALL	Current auto differential – Fixed by PIM.
PUMP POST	ALL	Sets the length of the boiler pump purge.
FLAME CUR	ALL	Flame current in micro-amps (µA).
MASS	ALL	Thermal mass recovery, see VERSA IC [®] manual 241493.
IDENTITY	ALL	Identifies the unit as boiler, water heater or pool heater.
IGN TYPE	ALL	PIM Board type.
ID CARD	ALL	Identifies Raypak Identity Card.
SW ID	ALL	PIM Software identification number.
ERROR CODE	ALL	Current Error Code.

*Fixed values based on ID card.

Table Q. Boiler Menu

Monitor Menu

The Monitor Menu records and displays critical Boiler information, such as, Cycle times, Run times, and Maximum/Minimum temperature readings depending on the setup.

Item	Application	Description
RUN TIME Burner 1	All	Burner run time (hours). Press UP/DOWN for 1 sec to clear.
Cycles Burner	All	Number of burner cycles. Press UP/DOWN for 1 sec to clear.
RUN TIME Boiler pump	All	Boiler pump run time (hours). Press UP/DOWN for 1 sec to clear.
RUN TIME System pump	All	System pump run time (hours). Press UP/DOWN for 1 sec to clear.
RUN TIME DHW pump	H MODE 2, 3	DHW pump run time (hours). Press UP/DOWN for 1 sec to clear.
OUTLET HI	All	Records the highest boiler outlet temperature. Press UP/DOWN for 1 sec to clear.
OUTLET LO	All	Records the lowest boiler outlet temperature. Press UP/DOWN for 1 sec to clear.
INLET HI	All	Records the highest boiler inlet temperature. Press UP/DOWN for 1 sec to clear.
INLET LO	All	Records the lowest boiler outlet temperature. Press UP/DOWN for 1 sec to clear.
DELTA T	All	Captures the highest Delta T temperature recorded Press UP & DOWN buttons for 3 sec to clear this entry.
OUTDOOR HI	H MODE 1, 2, 3	Records the highest outdoor temperature. Press UP/DOWN for 1 sec to clear.
OUTDOOR LO	H MODE 1, 2, 3	Records the lowest outdoor temperature. Press UP/DOWN for 1 sec to clear.
SYSTEM HI	All	Records the highest supply temperature. Press UP/DOWN for 1 sec to clear.
SYSTEM LO	All	Records the lowest supply temperature. Press UP/DOWN for 1 sec to clear.
IND HI	H MODE 1, 2, 3	Records the highest Indirect supply temperature. Press UP/DOWN for 1 sec to clear.
IND LO	H MODE 1, 2, 3	Records the lowest Indirect supply temperature. Press UP/DOWN for 1 sec to clear.
TANK HI	WH	Records the highest Tank temperature. Press UP/DOWN for 1 sec to clear.
TANK LO	WH	Records the lowest Tank temperature. Press UP/DOWN for 1 sec to clear.
POOL HI	P	Records the highest pool temperature. Press UP/DOWN for 1 sec to clear.
POOL LO	P	Records the lowest pool temperature. Press UP/DOWN for 1 sec to clear.

Table R. Monitor Menu

Toolbox Menu

The Toolbox Menu logs all error codes from the VERSA and PIM, as well as other functions. Up to 15 error codes can be logged for a maximum of 24 days.

Item	Description
Lookup Active Error	Look up and display the active error info.
USER TEST	Select ON to start the function. The setting returns to default after the test is run. (See "User Test" on page 52 for details.)
MAX HEAT	Select ON to start the function. The setting will time out to OFF after 24 hours or can be set to OFF again by the user. (See VERSA IC [®] manual for details.)
J1214I	Software number of the Raypak VERSA
DEFAULTS	Resets to factory settings. Press UP and DOWN for 1 second to show CLR and load factory defaults to all settings. This will also clear all history.
HISTORY lookup logged error	Displayed when an error code is present. 1 indicates the most recent error code. Press UP and DOWN for 1 second to clear the error logs.

Table S. Toolbox Menu

Outdoor Reset Concept

The Temperature controller can change the System Set Point based on outdoor temperature (Outdoor Reset). The temperature controller varies the temperature of the circulating heating water in response to changes in the outdoor temperature. The heating water temperature is controlled through the modulation and/or sequencing of the cascade. The Temperature controller can also control the system circulating pump with an adjustable Outdoor Cutoff.

When the outdoor temperature is above the Outdoor Cutoff, the pump is turned off and no heating water is circulated through the system. When the outdoor temperature drops below the Outdoor Cutoff, the system pump relay is activated and the heating water circulates through the system. The temperature of the heating water is controlled by the Reset Ratio, Water Offset, and changes with the outdoor temperature.

Reset Ratio/Outdoor Reset

When a building is being heated, heat escapes through the walls, doors, and windows to the colder outside air. The colder the outside temperature, the more heat escapes. If you can input heat into the building at the same rate that it is lost out of the building, then the building temperatures will remain constant. The Reset Ratio is an adjustment that lets you achieve this equilibrium between heat input and heat loss. The starting point for most systems is the 1.00 (OD):1.00 (SYS) (Outdoor Temperature: Heating Water Temperature) ratio. This means that for every degree the outdoor temperature drops, the temperature of the heating water will increase one degree.

With the VERSA, both ends of the slope are adjustable. It is factory set at 70°F (21°C) water temperature (Boil START) at 70°F (21°C) outdoor air (OUT START), and 180°F (82°C) water temperature (Boil DESIGN) at 10°F (-12°C) outdoor air (OUT DESIGN).

Each building has different heat loss characteristics. A very well insulated building will not lose much heat to the outside air, and may need a Reset Ratio of 2.00 (OD):1.00 (SYS) (Outdoor: Water). This means the outdoor temperature would have to drop 2 degrees to increase the water temperature 1 degree. On the other hand, a poorly insulated building may need a Reset Ratio of 1.00 (OD):2.00 (SYS). This means that for each degree the outdoor temperature dropped the water temperature will increase 2 degrees.

The VERSA Reset Ratio allows for full customization to match any buildings heat loss characteristics. A heating curve that relies not only on Outdoor temperature but also on the type of radiation will improve heat comfort. The user can fine tune these adjustments based on the specific building need.

Reset Ratio Settings

The controller uses the four following settings to determine the reset ratio:

1. Boiler Start (**Boil START**). The Boil START temperature is the theoretical boiler supply water temperature that the heating system requires when the outdoor air temperature equals the OUT START temperature setting. The Boil START is typically set to the desired building temperature.
2. Outdoor Start (**OUT START**). The OUT START temperature is the outdoor temperature at which the control provides the Boil START water temperature to the system. The OUT START is typically set to the desired building temperature.
3. Outdoor Design (**OUT DESIGN**). The OUT START is the outdoor temperature that is typical coldest annual temperature where the building is located. This temperature is used when completing heat loss calculation for the building.
4. Boiler Design (**Boil DESIGN**). The Boil DESIGN temperature is the water temperature required to heat the boiler zones when the outdoor air is as cold as the OUT DESIGN temperature.

Warm Weather Shut Down (WWSD)

When the outdoor air temperature rises above the WWSD setting, the control turns on the WWSD segment in the display. When the control is in the Warm Weather Shut Down, the Dem 1 segment is displayed if there is a heat demand. However, the control does not operate the boiler to satisfy this demand. The control continues to respond to DHW demands.

Reset Ratio

The controller uses the following four settings to calculate the Reset Ratio (RR). For example, when using the default values, the RR is:

$$\text{RESET RATIO} = \frac{(\text{OUTDOOR START} - \text{OUTDOOR DESIGN})}{(\text{BOILER DESIGN} - \text{BOILER START})}$$

$$\text{RR} = (70 - 10) / (180 - 70) = 0.55$$

Therefore, the RR is 0.55:1 (Outdoor : Water).

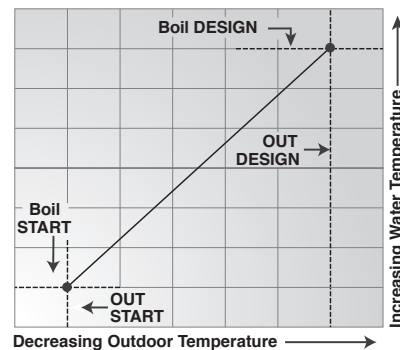
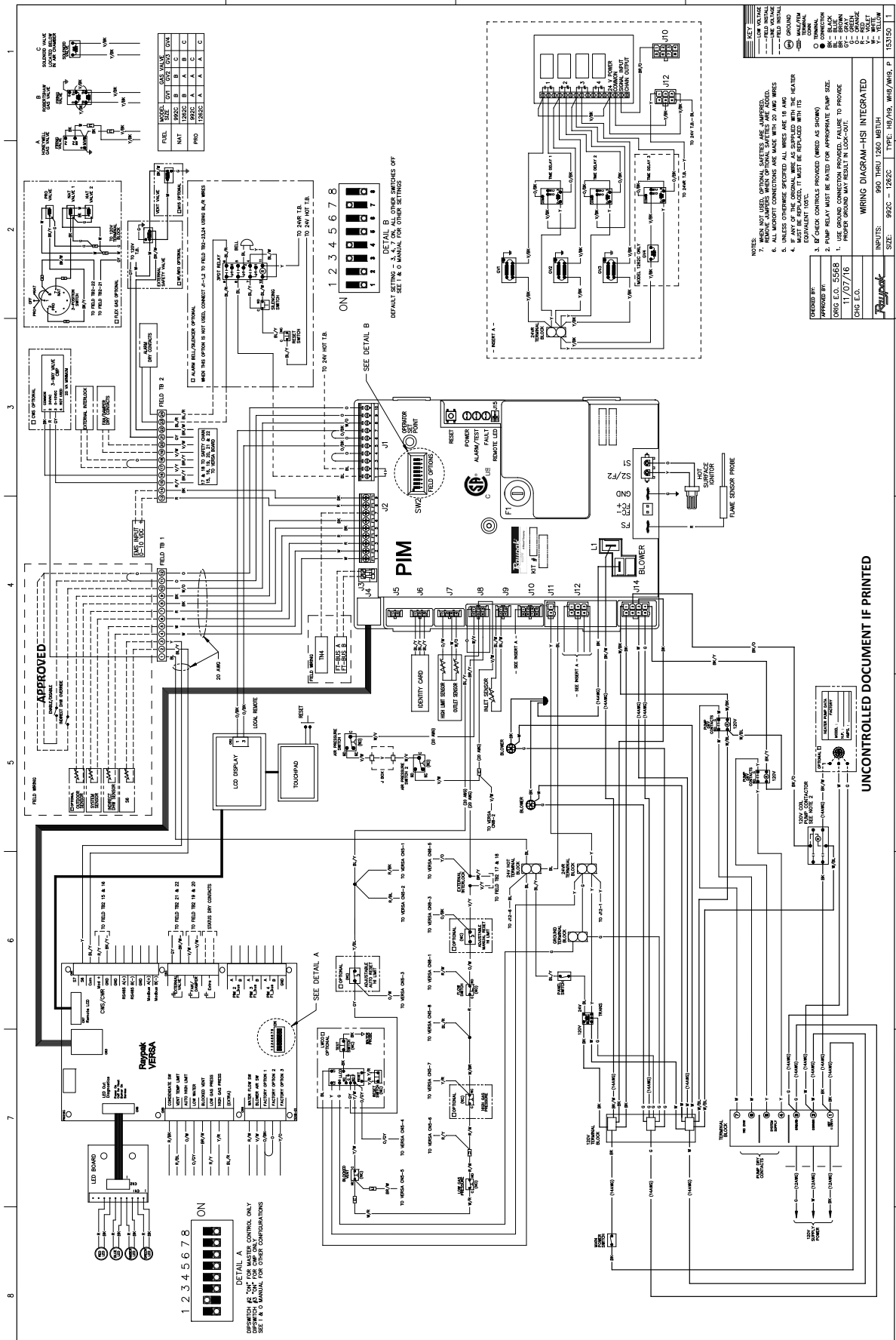

Figure 49. Reset Ratio

NOTE: The wiring diagrams in this manual show all standard options. Refer to the large wiring diagram provided with your boiler for options installed on your specific unit(s).

Wiring Diagram—Models 992C–1262C



For a full-size drawing visit: www.raypak.com/commercial/wiring_diagrams

5. START-UP

Pre Start-up

Filling System (Heating Boilers)

Fill system with water. Purge all air from the system. Open valves for normal system operation.

Air Purge (Domestic Hot Water Heaters)

Purge all air from system before lighting heater. This can be normally accomplished by opening a downstream valve.

Venting System Inspection

1. Check all vent pipe connections and flue pipe material.
2. Make sure vent terminations are installed per code and are clear of all debris or blockage.

For Your Safety

⚠ WARNING: If you do not follow these instructions exactly, a fire or explosion may result causing property damage, personal injury or loss of life.

This appliance has a hot surface igniter. It is equipped with an ignition device which automatically lights the burners. Do not try to light the burners by hand.

BEFORE OPERATING, smell all around the appliance area for gas. Be sure to smell near the floor because some gas is heavier than air and will settle on the floor.

WHAT TO DO IF YOU SMELL GAS:

- Do not try to light any appliance.
- Do not touch any electrical switch; do not use any telephone in your building.
- Immediately call your gas supplier from a neighbor's telephone. Follow the gas supplier's instructions.
- If you cannot reach your gas supplier, call the fire department.
- Use only your hand to push in or turn the gas control knob. Never use tools. If the knob will not turn by hand, do not try to repair it, call a qualified service technician. Forced or attempted repair may result in a fire or explosion.
- Do not use this appliance if any part has been under water, immediately call a qualified service technician to inspect the appliance and to replace any part of the control system and any gas control which has been under water.
- Check around unit for debris and remove combustible products, i.e. gasoline, etc.

Pre Start-up Check

1. Verify heater is filled with water.
2. Check system piping for leaks. If found, repair immediately.
3. Vent air from system. Air in system can interfere with water circulation.
4. Purge air from gas line up to heater.

Initial Start-up

Tools Needed

- (1) 12-0-12, 24" scale U-tube manometer
- (4) 6-0-6, 12" scale U-tube manometers (minimum)
- (1) Screwdriver
- (1) Multi-meter

NOTE: Digital manometers are not recommended.

Preparation

⚠ WARNING: Do not turn on gas at this time.

Check Power Supply

With multi-meter at incoming power, check voltage between:

- Hot - Common (≈ 120 VAC)
- Hot - Ground (≈ 120 VAC)
- Common - Ground (< 1 VAC)

⚠ WARNING: If Common - Ground is > 1 VAC, STOP: Contact electrician to correct ground failure. Failure to do this may burn out 120V-24V transformer, or may cause other safety control damage or failure.

Attach Manometers to Measure Pressures

1. Turn off main gas valve.
2. Attach 24" scale manometer to the first main gas shutoff valve pressure tapping.
3. Attach (1) 12" scale manometer to the outlet side of the second main gas shutoff valve pressure tapping.
4. Attach (1) 12" scale manometer near the fan-proving switch. Pull black cap from air pressure switch tee and connect the manometer.

NOTE: Retain caps for reinstallation later.

Check Gas Supply Pressure

1. Slowly turn on main gas shutoff valve.
2. Read the gas supply pressure from the manometer; minimum supply pressure for natural gas is 5.6 in. WC, recommended supply is 7.0 in. WC, minimum supply pressure for propane gas is 11.0 in. WC (dynamic readings, all stages firing).
3. If the pressure is > 14.0 in. WC, turn off the valve.
4. Check if the service regulator is installed and/or adjust the service regulator.

Start-Up

Blower Adjustment

1. Turn off power.
2. Unplug cap at pressure switches and connect manometer(s) to the tee.
3. Close all manual firing valves.
4. Turn power on.
5. Check manometers attached to fan pressure switch. The reading should be $1.4 \pm .1$ in. WC for propane gas and natural gas. If not, adjust the air shutter on the blowers to attain the correct value.
6. Turn power off.
7. Reconnect this cap.

Main Burner Adjustment

1. Turn off unit.
2. Open manual firing valves.
3. Turn on the unit, wait 15 seconds, and the igniter should glow. Look into sight glass located at each end of the heater to check igniter operation. Gas valves should open in 45-60 seconds.
4. If burner does not light on first trial, it will retry up to three times for the standard module.
5. Main burner ignition: Check manifold gas pressure at gas valve outlet pressure tap. This should read 3.5 ± 0.1 in. WC for natural gas and 10.5 ± 0.1 in. WC for propane gas.
6. If the pressure reading differs by more than ± 0.1 in. WC, remove screw cover from the gas pressure regulator and adjust main burner manifold pressure. Replace the screw cover. Repeat steps 3 to 5 on other valves as necessary.

CAUTION: Special manifold and air settings may be required. Verify rating plate and blower housing.

Safety Inspection

1. Check all thermostats and high limit settings.
2. During the following safety checks leave manometers hooked up, check and record.
3. If other gas-fired appliances in the room are on the same gas main, check all pressures on the Hi Delta with all other equipment running.
4. Check thermostats for ON-OFF operation.
5. Check high limits for ON-OFF operation.
6. While in operation, check flow switch operation.
7. Check the low gas pressure switch. (For proper adjustment, use the attached manometers, if available, to set pressure. The scales on the switch are approximate only.) Low gas pressure switch must be set at 5.0 in. WC for natural gas and 10.0 in. WC for propane gas.
8. Make sure that the high gas pressure switch (if present) is set to 5.0 in. WC for natural gas and 11.5 in. WC for propane gas.

Follow-Up

Safety checks must be recorded as performed.

Turn heater on. After main burner ignition:

1. Check manometer for proper reading.
2. Cycle heater several times and re-check readings.
3. Remove all manometers and replace caps and screws.
4. Replace all gas pressure caps.
5. Check for gas leaks one more time.

User Test

Set DIP switch #1 on the VERSA IC® control to "ON". Set USER TEST = ON in the 'ToolBox' Menu to start the user test function.

- USER TEST is displayed in the Title Field.
- UP keystrokes are used to advance through the user test.
- The Boil MIN/MAX steps for burner operation are only run for enabled boilers.
- Local Heat/DHW/EMS demands must be present for burner operation.
- On the first press of the Up button, the test step is held and "HOLD" is flashed at 1Hz.
- On the second press of the Up button, the test step is incremented.
- If boiler outlet temperature reaches the PIM Hi-Limit, the boiler will be ramped down to keep the temperature in a safe range.

- Press of the Up button from Boiler Max will End the User Test function.
- When CWP is enabled (VERSA DIP #3) VALV will become available during USER TEST.

Number Field	Output Action
SYS	System Pump relay turns on.
DHW	DHW Pump relay turns on.
PMP 1	System and Boiler Pump relays turn on.
CWP	CWP proportional output
Boil 1	Ignite Boiler Burner.
Min 1	Hold Boiler at Min Fire.
Max 1	Ramp Boiler to Max Fire and hold.

Table T. User Test Fields

Leak Test Procedure: Dual-Seat Gas Valves

Proper leak testing requires three pressure test points in the gas train. Refer to **Figure 50**. The numbers on the diagram refer to the steps below:

Test point A is upstream of the automatic gas valve. On the first automatic valve, this is a bleedle valve. On the other valves, this is a plugged port. The bleedle valve on the first valve may be used for all the other valves as well.

Test point B is a bleedle valve located between the two automatic gas valve seats.

Test point C is located downstream of both automatic gas valve seats and upstream of the manual valve. On the manual valve, this is a bleedle valve. Identical readings will be found at the plugged port labeled as Alternate C.

These tests are to be conducted with the electrical power to the heater turned off.

1. Manually close the downstream leak test valve.
2. Open test point A and connect a manometer to it. Verify that there is gas pressure and that it is within the proper range (NOTE: must not exceed 14.0 in. WC).
3. Open test point B and connect a rubber tube to it. Connect the other end of the tube to a manometer and look for a build-up of pressure. Increasing pressure indicates a leaking gas valve.
4. Next, close the upstream manual gas valve and remove the manometer from test point A and from test point B. Connect a rubber tube from test point A to test point B and open the upstream manual gas valve. Make sure that test points A & B have been opened so as to allow gas to flow. This will bring pressure to the second valve seat.
5. Open test point C and connect a second rubber tube to it. Connect the other end of the tube to a manometer and look for a build-up of pressure.

Increasing pressure indicates a leaking gas valve.

6. Remove rubber tube and manometers. Close each test point valve as the tubes are removed.
7. Connect a manometer to each test point (one at a time) and look for a build-up of pressure. If a build-up of pressure is detected, check each test point valve to see if it is tightly closed. If leak persists, replace test point valve(s).
8. After no leakage has been verified at all valve seats and test valves, open downstream leak tests valve and restore electrical power to heater.

This completes leak testing for a single Hi Delta manifold riser. Repeat steps 1-8 for each riser.

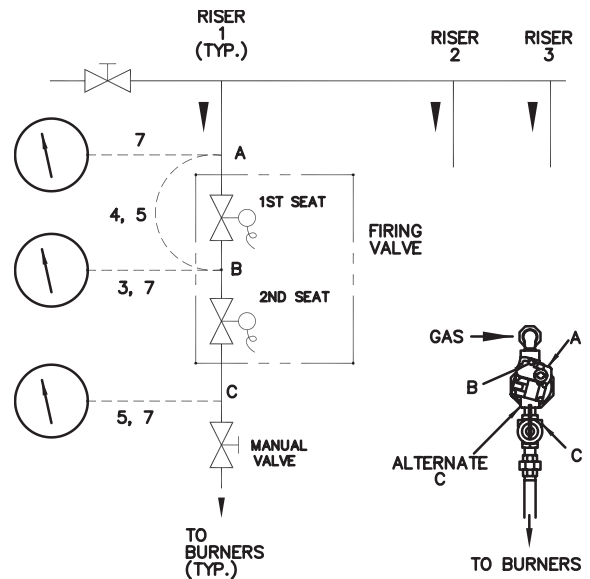

Figure 50. Leak Test

Post Start-Up Check

Check off steps as completed:

1. Verify that the heater and heat distribution units or storage tank are filled with water.
2. Confirm that the automatic air vent (if used) was opened two full turns during the venting procedure.
3. Verify that air has been purged from the system.
4. Verify that air has been purged from the gas piping, and that the piping has been checked for leaks.
5. Confirm that the proper start-up procedures were followed.
6. Inspect burner to verify flame.
7. Test safety controls: If heater is equipped with a low water cut-off or additional safety controls, test for operation as outlined by manufacturer. Burner should be operating and should go off when controls are tested. When safety devices are restored, burners should re-ignite after pre-purge time delay.
8. Test fixed high limit function: When the PIM DIP switch #8 is turned to the ON position, a Commission Test

Mode is activated. The PIM lights the amber Alarm/Test LED. This mode activates certain functions to assist initial commission testing of the system. The configured high limit temperature is overridden to match the setpoint potentiometer position. The high limit can then be adjusted by the potentiometer to assist commission testing and verification. The operating setpoint is automatically set to 20°F (11°C) above the high limit (stand-alone mode), or it can be controlled by the VERSA IC® Control.

9. Test ignition system safety device:
 - a. Turn on manual gas valve. Turn power on.
 - b. Set thermostat to call for heat.
 - c. When the heater is in operation, pull cap off of tee in air switch hose. The burner should go off immediately.
 - d. Wait 5 minutes.
 - e. Reattach cap on tee. Burner should re-ignite after pre-purge time delay.
10. To restart system, follow lighting instructions in the Operation section.
11. Check to see that the adjustable high limit control, if provided, is set above the design temperature requirements of the system.

For multiple zones: Check to make sure the flow is adjusted as required in each zone.
12. Check that the heater is cycled with the thermostat. Raise to the highest setting and verify that the heater goes through the normal start-up cycle. Reduce to the lowest setting and verify that the heater goes off.
13. Observe several operating cycles for proper operation.
14. Set the room thermostat or tankstat to desired temperature.
15. Review all instructions shipped with this heater with owner or maintenance person, return to envelope and give to owner or place the instructions inside front panel on heater.

6. Turn on main manual gas valve.
7. Wait 5 minutes to clear out any gas. Then smell for gas, especially near the floor. If you then smell gas, STOP! Follow the steps in the safety information on the front cover of this manual. If you do not smell gas, go to next step.
8. Turn on all electrical power to the appliance.
9. Provide contact closure across the Enable/Disable terminals at the field wiring block.
10. Set thermostat to desired setting. The appliance will operate. The igniter will glow after the pre-purge time delay (15 seconds). After igniter reaches temperature (45 seconds) the main valve will open. System will try for ignition three times with standard ignition module. If flame is not sensed, lockout will commence.
11. If the appliance will not operate, follow the instructions "To Turn Off Gas To Appliance," and call your service technician or gas supplier.
12. Replace access panel.
13. If heater fails to start, verify the following:
 - a. There are no loose connections or that the service switch is off.
 - b. Adjustable high temperature limit switch is set above water temperature (if provided).
 - c. Thermostat is set above room temperature.
 - d. Gas is on at the meter and the heater.
 - e. Incoming gas pressure to the gas valve is NOT less than 5.0 in. WC for natural gas, 11.0 in. WC for propane gas.

To Turn Off Gas To Appliance

1. Set the thermostat to lowest setting.
2. Turn off all electrical power to the appliance if service is to be performed.
3. Remove upper front panels.
4. Turn off main manual gas valve.
5. Replace access panel.

6. OPERATION

Lighting Instructions

1. Before lighting, make sure you have read all of the safety information in this manual.
2. Set the thermostat to the lowest setting.
3. Turn off all electrical power to the appliance.
4. This appliance is equipped with an ignition device which automatically lights the burner. Do not try to light the burner by hand.
5. Remove upper front panel.

7. MAINTENANCE

Suggested Minimum Maintenance Schedule

Regular service by a qualified service agency and maintenance must be performed to ensure maximum operating efficiency.

Maintenance as outlined below may be performed by the owner.

Daily

1. Check that the area where the heater is installed is free from combustible materials, gasoline, and other flammable vapors and liquids.
2. Check for and remove any obstruction to the flow of combustion or ventilation air to heater.

Monthly

1. Check for piping leaks around circulators, mixing valves, relief valves, and other fittings. If found, repair at once. DO NOT use petroleum-based stop-leak compounds.
2. Visually inspect burner flame.
3. Visually inspect venting system for proper function, deterioration or leakage.
4. Check air vents for leakage.

Periodically

1. Check relief valve. Refer to manufacturer's instructions on valve.
2. Test low water cut-off, if used. Refer to manufacturer's instructions.
3. Clean intake screen, vent terminal screen and air filter.

Yearly (Beginning Of Each Heating Season)

Schedule annual service call by qualified service agency.

1. Visually check top of vent for soot. Call service person to clean. Some sediment at bottom of vent is normal.
2. Visually inspect venting system for proper function, deterioration or leakage.
3. Check that area is free from combustible materials, gasoline, and other flammable vapors and liquids.
4. Check for and remove any obstruction to the flow of combustion or ventilation air to heater.
5. Follow pre-start-up check in the Start-up section.
6. Visually inspect burner flame. It should be light blue. Remove and replace hot surface igniter and sensor.
7. Check operation of safety devices. Refer to manufacturers' instructions.

8. Follow oil-lubricating instructions on circulator if required. Over-oiling will damage circulator. Water-lubricated circulators do not need oiling.
9. To avoid potential of severe burn, DO NOT REST HANDS ON OR GRASP PIPES. Use a light touch; return piping will heat up quickly.
10. Check blower and blower motor.
11. Check for piping leaks around circulators, relief valves and other fittings. Repair, if found. DO NOT use petroleum-based stop-leak.
12. Clean air filter.
13. Conduct a combustion test at full fire. Carbon dioxide should be $8.2\% \pm 0.5\%$ at full fire for natural gas, and $9.4\% \pm 0.5\%$ for propane gas; Carbon monoxide should be < 150 ppm).

Preventive Maintenance Schedule

The following is required procedure in CSD-1 states and good practice for all Hi Delta installations.

Daily

1. Check gauges, monitors and indicators.
2. Check instrument and equipment settings. (See "Post Start-Up Check" on page 53.)
3. Check burner flame. (Should see light blue flame).

Weekly

For low-pressure heaters, test low-water cut-off device. (With at least one stage of the appliance on, depress the low water cut-off test button, appliance should shut off and ignition fault light should come on. Depress reset button to reset).

Monthly

1. Check flue, vent, stack, or outlet dampers.
2. Test fan air pressure. (See "Blower Adjustment" on page 52.)
3. Test high and low gas pressure interlocks (if equipped). (See "Safety Inspection" on page 52.)

Semi-Annually

1. Recalibrate all indicating and recording gauges.
2. Check flame failure detection system components.
3. Check firing rate control by checking the manifold pressure. (See "Main Burner Adjustment" on page 52.)
4. Check piping and wiring of all interlocks and shutoff valves.

Annually

1. Test flame failure detection system.
2. Test high limit and operating temperature. (See "Post Start-Up Check" on page 53.)
3. Check flame sensors.
4. Conduct a combustion test at full fire. Carbon dioxide should be $8.2\% \pm 0.5\%$ at full fire for natural gas, and $9.4\% \pm 0.5\%$ for propane gas; Carbon monoxide should be < 150 ppm.
5. Check coils for 60-cycle hum or buzz. Check for leaks at all valve fittings using a soapy water solution. Test other operating parts of all safety shutoff and control valves and increase or decrease settings (depending on the type of control) until the safety circuit opens. Reset to original setting after each device is tested.
6. Perform leakage test on gas valves. (See **Figure 50**.)
7. Test air switch in accordance with manufacturer's instructions. (Turn panel switch to the "On" position until blower is proven, then turn the switch to "Off").
8. Inspect and clean burners as necessary.

As Required

1. Recondition or replace low water cut-off device (if equipped).
2. Check drip leg and gas strainers.
3. Perform flame failure detection and pilot turn-down tests.
4. Check igniter. Amp draw should be 3.2 amps or greater during ignition.
5. Check flame signal strength. (Flame signal should be greater than 1 microamp).
6. Test safety/safety relief valves in accordance with ASME Heater and Pressure Vessel Code Sections VI and VII.

8. ILLUSTRATED PARTS LIST

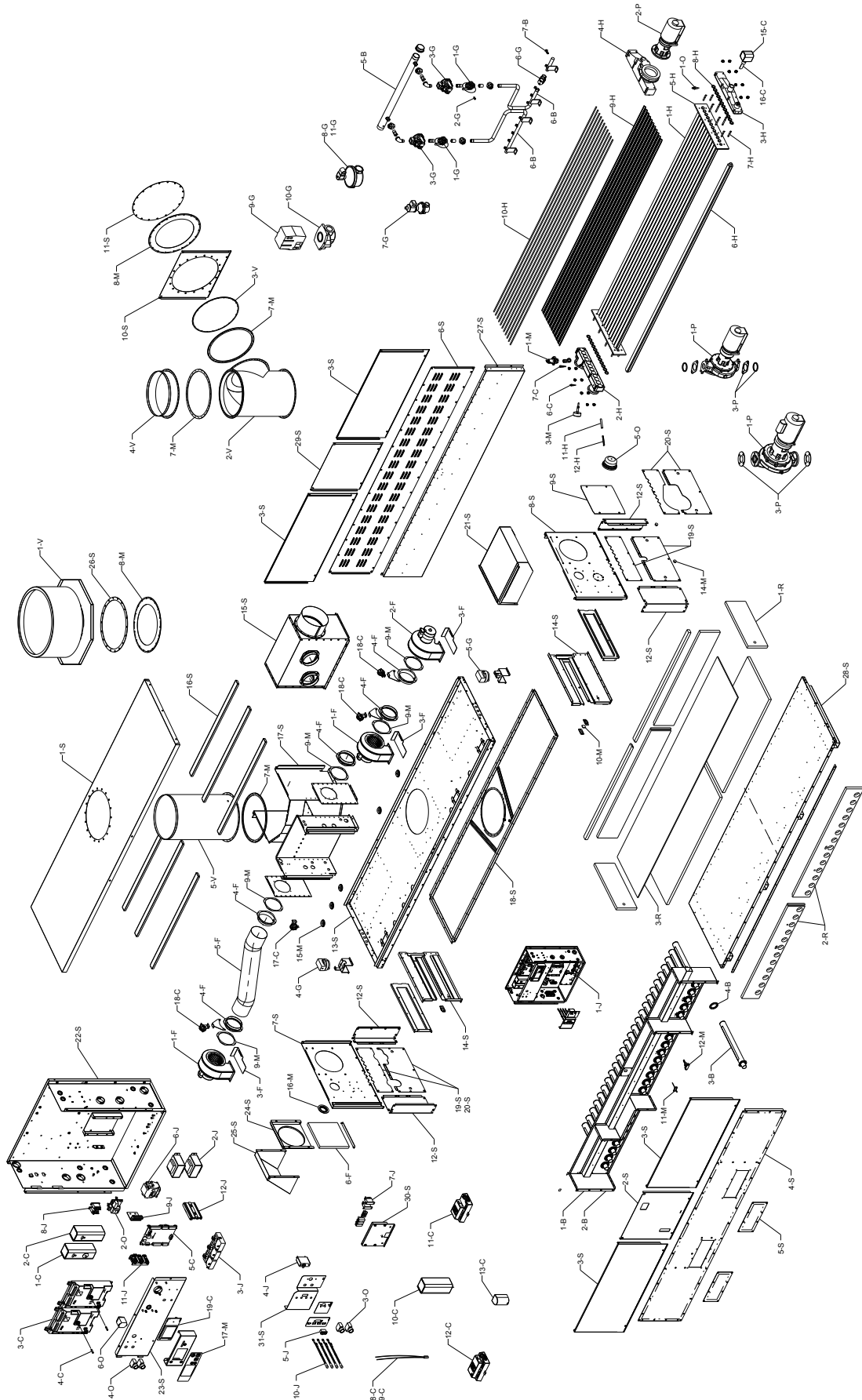

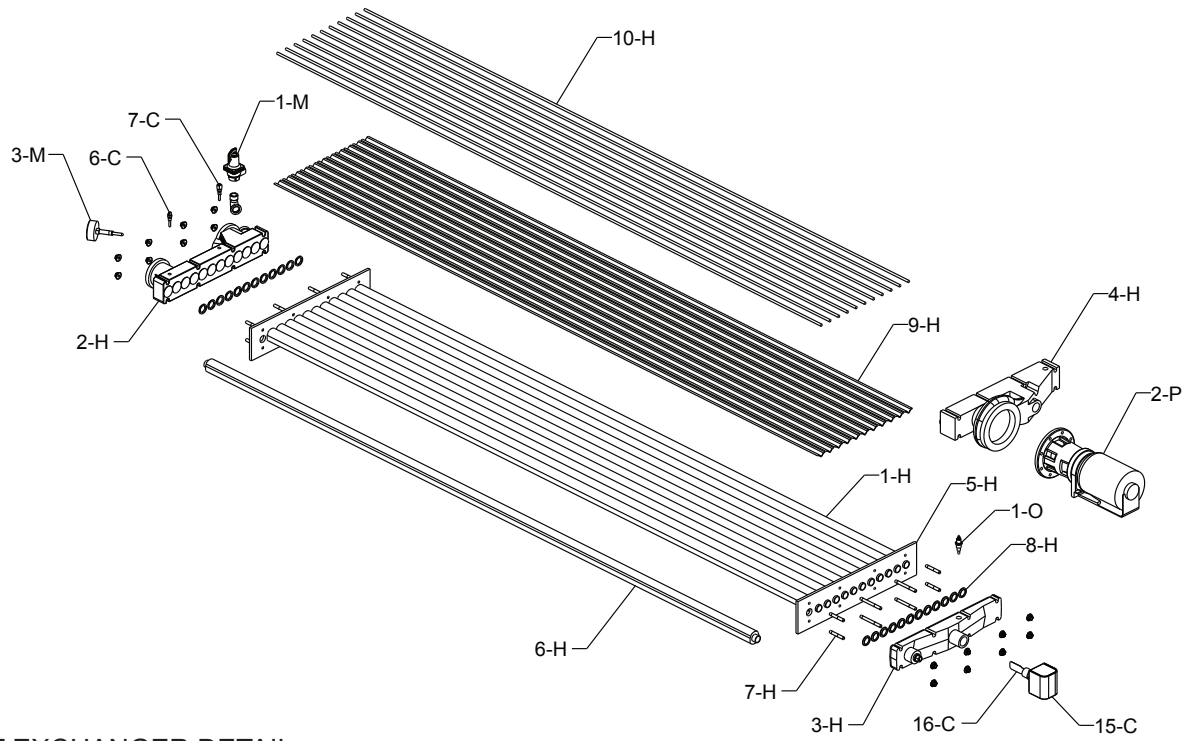

HEAT EXCHANGER DETAIL

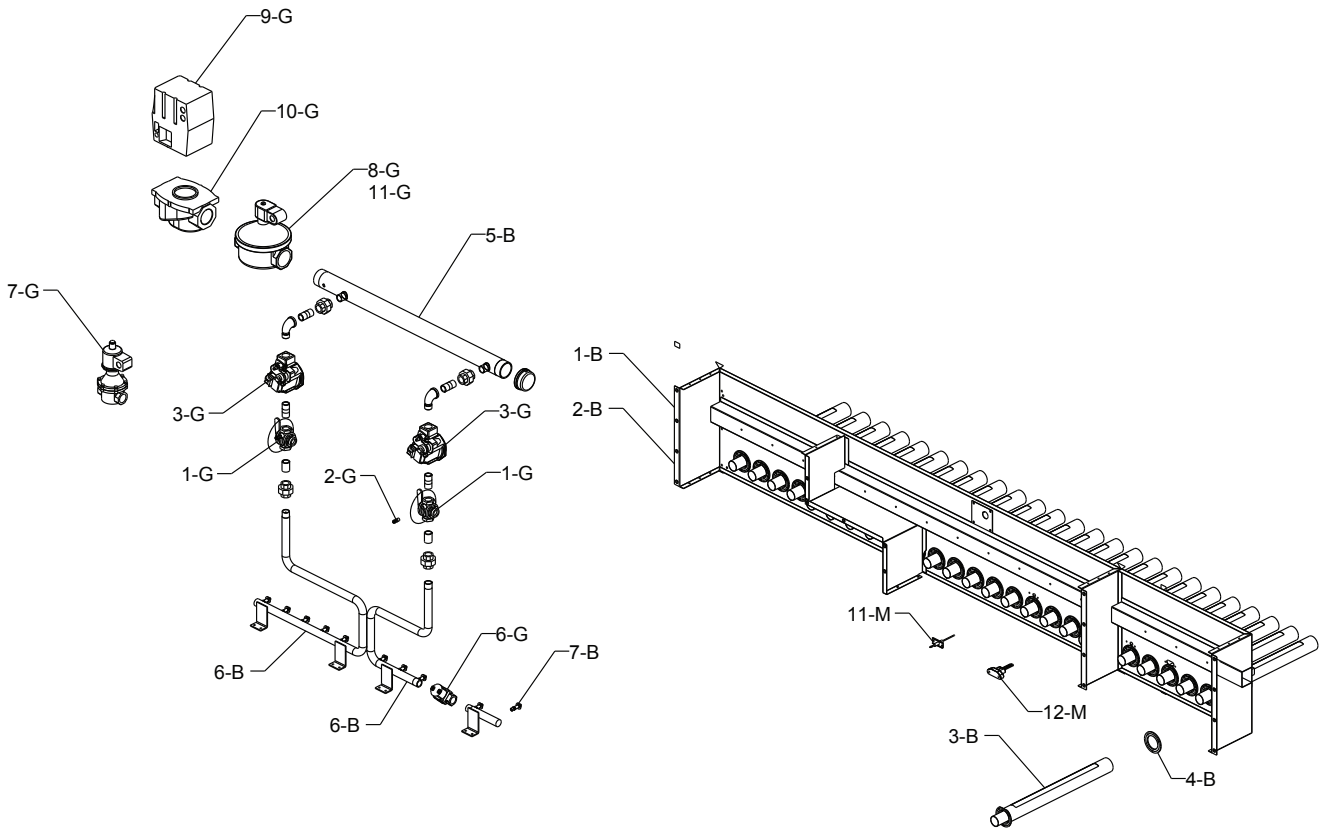

BURNER ASSEMBLY DETAIL

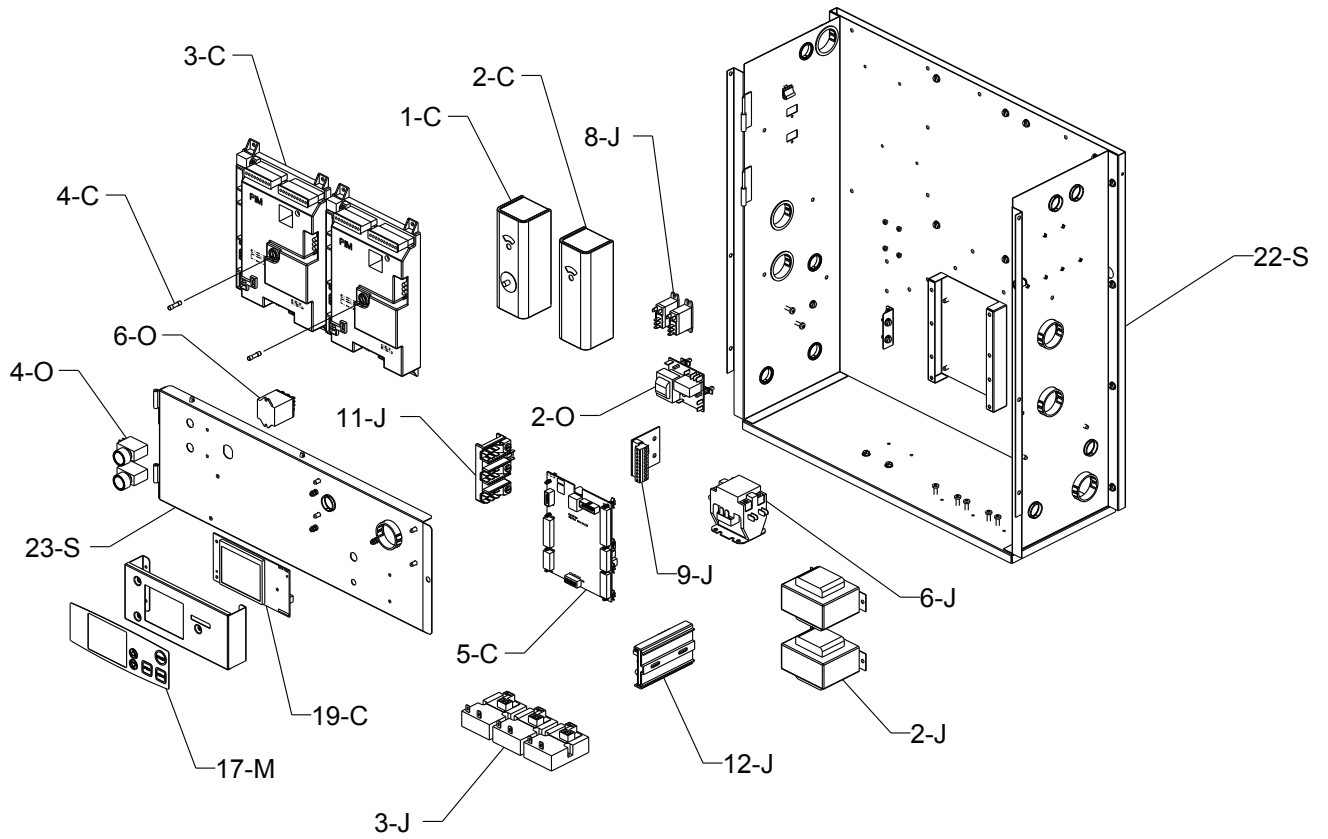

CONTROL BOX DETAIL

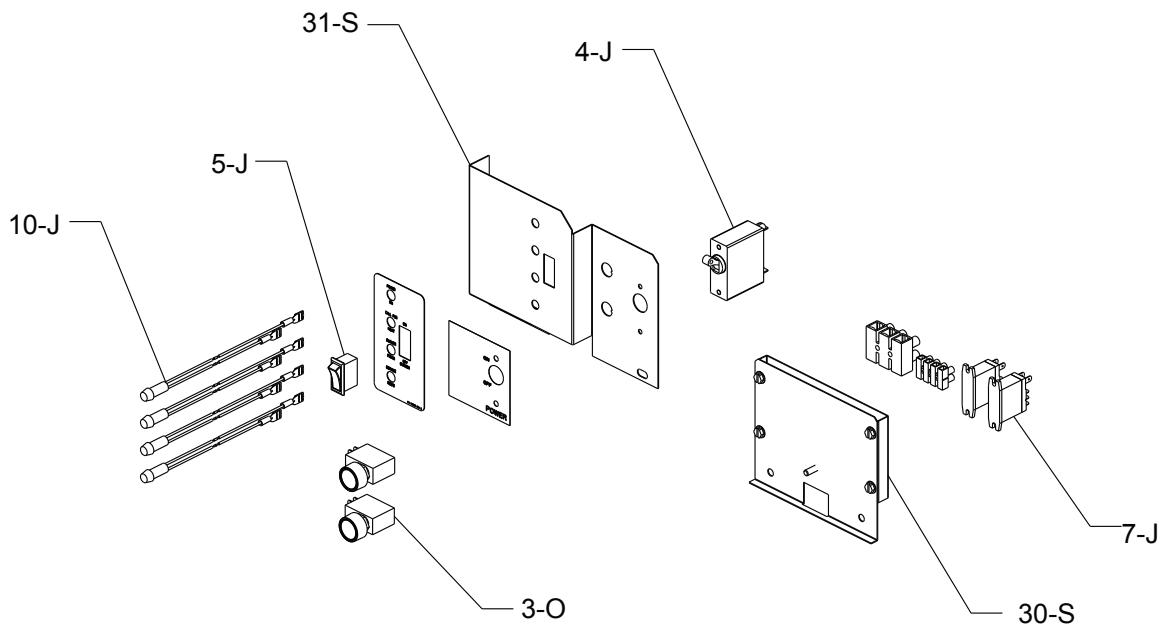

FRONT SWITCH DETAIL

CALL OUT	DESCRIPTION	992C	1262C	1532C	1802C	2002C	2072C	2342C
B BURNER ASSEMBLY								
1-B	Burner Assy w/Burners	009598F	009599F	009600F	009601F	009602F	009602F	009603F
2-B	Burner Mounting Assy	009604F	009605F	009606F	009607F	009608F	009608F	009609F
3-B	Burner	007617F/ 11	007617F/ 14	007617F/ 17	007617F/ 20	007617F/ 23	007617F/ 23	007617F/ 26
4-B	Seal Gasket	007443F	007443F	007443F	007443F	007443F	007443F	007443F
5-B	Manifold Upper	009610F	009611F	009612F	009613F	009614F	009614F	009615F
6-B	Manifold Lower	009616F	009617F	008972F	008973F	008974F	008974F	008975F
7-B	Burner Orifice * (All Elevations)							
	Natural Gas # 28 (Low Gas Pressure.)	351641/ 11	351641/ 14	351641/ 17	351641/ 20	N/A	351641/ 23	351641/ 26
	Natural Gas # 33	351444 / 11	351444 / 14	351444 / 17	351444 / 20	N/A	351444 / 23	351444 / 26
	Natural Gas # 35	N/A	N/A	N/A	N/A	351618 / 23	N/A	N/A
	Propane Gas # 52	351445 / 11	351445 / 14	351445 / 17	351445 / 20	N/A	351445 / 23	351445 / 26
C CONTROLS								
1-C	Manual Reset Adjustable High Limit 240°F Max	007144F	007144F	007144F	007144F	007144F	007144F	007144F
	Manual Reset Adjustable High Limit 200°F Max	008081F	008081F	008081F	008081F	008081F	008081F	008081F
	Manual Reset Adjustable High Limit 180°F Max	009554F	009554F	009554F	009554F	009554F	009554F	009554F
2-C	Auto Reset Adjustable High Limit 240°F Max	007141F	007141F	007141F	007141F	007141F	007141F	007141F
	Auto Reset Adjustable High Limit 180°F Max	006445F	006445F	006445F	006445F	006445F	006445F	006445F
	Auto Reset Adjustable High Limit 200°F Max	012546F	012546F	012546F	012546F	012546F	012546F	012546F
3-C	PIM (Platform Ignition Module) Multi Try	014324F	014324F	015997F	015997F	015997F	015997F	015997F
	PIM (Platform Ignition Module) Single Try CSD-1	014325F	014325F	015998F	015998F	015998F	015998F	015998F
4-C	Fuse 5 Amp (Fast Acting)	013971F	013971F	013971F	013971F	013971F	013971F	013971F
5-C	PC Board VERSA IC	013935F	013935F	013935F	013935F	013935F	013935F	013935F
6-C	Inlet Sensor (2 Wire)	013175F	013175F	013175F	013175F	013175F	013175F	013175F
7-C	Outlet/Limit Sensor (4 Wire)	013932F	013932F	013932F	013932F	013932F	013932F	013932F
8-C	System Water Sensor 10K	010787F	010787F	010787F	010787F	010787F	010787F	010787F
9-C	Indirect DHW Sensor 10K	010787F	010787F	010787F	010787F	010787F	010787F	010787F
10-C	Indirect Tank Aquastat Control B-65	007148F	007148F	007148F	007148F	007148F	007148F	007148F
11-C	Gateway BACnet Interface Module B-85	016617F	016617F	016617F	016617F	016617F	016617F	016617F
12-C	Gateway LonWorks Interface Module B-86	016618F	016618F	016618F	016618F	016618F	016618F	016618F
13-C	Sensor Outdoor Air B-32	010786F	010786F	010786F	010786F	010786F	010786F	010786F
15-C	Flow Switch	007142F	007142F	007142F	007142F	007142F	007142F	007142F
16-C	Flow Switch Paddle	010026F	010026F	010026F	010026F	010026F	010026F	010026F
17-C	Switch Air Pressure (Blocked Vent)	007158F	007158F	007158F	007158F	007158F	007158F	007158F
18-C	Switch Air Pressure Differential (Blower)	008171F	008171F	008171F	008171F	008171F	008171F	008171F
19-C	LCD Display PC Board	013939F	013939F	013939F	013939F	013939F	013939F	013939F
F FAN								
1-F	Blower Combustion Air (Left Hand)	007413F	007413F	007413F	007413F	007413F	007413F	007413F
2-F	Blower Combustion Air (Right Hand)	007414F	007414F	007414F	007414F	007414F	007414F	007414F
3-F	Air Shutter	009618F	009618F	009618F	009618F	009618F	009618F	009618F
4-F	Intake Blower Flange 6" (Truseal)	009697F	009697F	009697F	009697F	009697F	009697F	009697F
	Intake Blower Flange 4" (Truseal)	011746F	N/A	N/A	N/A	N/A	011746F	011746F
5-F	Hose Duct 6" (Truseal)	007420F	007420F	007420F	007420F	007420F	007420F	007420F
	Hose Duct 4" (Truseal)	007419F	N/A	N/A	N/A	N/A	007419F	007419F
6-F	Filter Media	008402F	008402F	008402F	008402F	008402F	008402F	008402F
G GAS VALVES **								
1-G	Valve Gas Manual A 3/4"	007421F	007421F	007421F	007421F	007421F	007421F	007421F
	Valve Gas Manual A 1" (Low Gas Press.)	007189F	007189F	007189F	007189F	007189F	007189F	007189F
2-G	Bleedle Valve 1/4"	007422F	007422F	007422F	007422F	007422F	007422F	007422F
	Bleedle Valve 1/8"	007423F	007423F	007423F	007423F	007423F	007423F	007423F
3-G	Gas Valve Nat 3/4" Robertshaw 601605							
	Gas Valve Pro 3/4" Robertshaw 601604							
	Gas Valve Nat 3/4" Honeywell 601561							
	Gas Valve Pro 3/4" Honeywell 601563							
	Gas Valve Nat 1" (G-20 Low Gas Pressure) Robertshaw 601784	011732F	011732F	011732F	011732F	011732F	011732F	011732F
4-G	Switch Low Gas Pressure w/o Bracket	007187F	007187F	007187F	007187F	007187F	007187F	007187F
5-G	Switch High Gas Pressure w/o Bracket (Optional)	007188F	007188F	007188F	007188F	007188F	007188F	007188F
6-G	Solenoid Gas Valve	008407F	008407F	N/A	N/A	N/A	N/A	N/A
7-G	Vent Valve (G-2 & M15 Vent Valve Option)	011914F	011914F	011914F	011914F	011914F	011914F	011914F
8-G	Solenoid Safety Shut Off Valve (G-2 Vent Valve Option)	011911F	011911F	011911F	011911F	011911F	011911F	011911F
9-G	Motorized Safety Shut Off Actuator M-1(Optional)	011908F	011908F	011908F	011908F	011908F	011908F	011908F
10-G	Gas Valve Body M1(Optional)	014558F	014558F	014558F	014558F	014558F	014558F	014558F
11-G	Solenoid Safety Shut Off Valve M-10 (Optional)	011911F	011911F	011911F	011911F	011911F	011911F	011911F

* DO NOT re-orifice for elevations above 4500ft. Consult the factory for changes required for proper combustion at elevations above 4500ft.

**For units provided with flex gas option see Catalog 1000.58.

CALL OUT	DESCRIPTION	992C	1262C	1532C	1802C	2002C	2072C	2342C
H HEAT EXCHANGER								
1-H	Heat Exch Cast Iron	016551F	016552F	016553F	016554F	016555F	016555F	016556F
	Heat Exch Brass	016557F	016558F	016559F	016560F	016561F	016561F	016562F
	Heat Exch Cast Iron w/Pump Hdr	016563F	016564F	016565F	N/A	N/A	N/A	N/A
	Heat Exch Brass w/Pump Hdr	016566F	016567F	016568F	N/A	N/A	N/A	N/A
	Heat Exch Cast Iron Cupro Nickel	016569F	016570F	016571F	016572F	016573F	016573F	016574F
	Heat Exch Cast Iron Cupro Nickel with Steel Rod Baffles *	016410F	016411F	016412F	016413F	016414F	016414F	016415F
	Heat Exch Brass Cupro Nickel	016575F	016576F	016577F	016578F	016579F	016579F	016580F
	Heat Exch Brass Cupro Nickel with Steel Rod Baffles *	016333F	016334F	016335F	016336F	016337F	016337F	016338F
	Heat Exch Cast Iron w/Pump Hdr Cupro Nickel	016581F	016582F	016583F	N/A	N/A	N/A	N/A
	Heat Exch Cast Iron w/Pump Hdr Cupro Nickel & Steel Rods Baffle	016422F	016423F	016424F	N/A	N/A	N/A	N/A
	Heat Exch Brass w/Pump Hdr Cupro Nickel	016584F	016585F	016586F	N/A	N/A	N/A	N/A
	Heat Exch Brass w/Pump Hdr Cupro Nickel & Steel Rods Baffles *	016345F	016346F	016347F	N/A	N/A	N/A	N/A
2-H	Inlet/Outlet Header Cast Iron	016587F	016587F	016587F	016587F	016587F	016587F	016587F
	Inlet/Outlet Header Brass	016588F	016588F	016588F	016588F	016588F	016588F	016588F
3-H	Return Header Cast Iron	007718F	007718F	007718F	007718F	007718F	007718F	007718F
	Return Header Brass	007719F	007719F	007719F	007719F	007719F	007719F	007719F
4-H	Return Pump Header Cast Iron	007720F	007720F	007720F	N/A	N/A	N/A	N/A
	Return Pump Header Brass	007721F	007721F	007721F	007721F	N/A	N/A	N/A
5-H	Tube Bundle	007722F	007723F	007724F	007725F	007726F	007726F	007727F
	Tube Bundle Cupro Nickel	007728F	007729F	007730F	007731F	007732F	007732F	007733F
	Tube Bundle Cupro Nickel with Steel Rod Baffles	016355F	016356F	016357F	016358F	016359F	016359F	016360F
6-H	Heat Exchange Tube	007734F	007735F	007736F	007737F	007738F	007738F	007739F
	Heat Exchange Tube Cupro Nickel	007740F	007741F	007742F	007743F	007744F	007744F	007745F
7-H	Stud Bolt Kit	007828F	007828F	007828F	007828F	007828F	007828F	007828F
	Stud Bolt Kit w/Pump Header	007829F	007829F	007829F	007829F	007829F	007829F	007829F
8-H	Header Gasket	007834F	007834F	007834F	007834F	007834F	007834F	007834F
9-H	Baffle Kit "WH" and "P" units only	007858F	007859F	007860F	007861F	007862F	007862F	007863F
10-H	Steel Rod Baffle Kit "WH" units only"	016321F	016322F	016323F	016324F	016325F	016325F	016326F
11-H	Sensor Well	007211F	007211F	007211F	007211F	007211F	007211F	007211F
12-H	Well Retaining Clip	300203	300203	300203	300203	300203	300203	300203
J CONTROL BOX								
1-J	Control Box	N/A	N/A	N/A	N/A	N/A	N/A	N/A
2-J	Transformer 100 VA	007494F	007494F	007494F	007494F	007494F	007494F	007494F
3-J	Time Delay Contactor	008921F	008921F	N/A	N/A	008921F	008921F	008921F
4-J	Automatic Shut Down Breaker Switch 30 AMP	007380F	007380F	007380F	007380F	007380F	007380F	007380F
5-J	On/Off Switch Rocker	006872F	006872F	006872F	006872F	006872F	006872F	006872F
6-J	Pump Contactor DPST 120vac	007906F	007906F	007906F	007906F	007906F	007906F	007906F
7-J	Pump Dry Contact Relay 120V	012126F	012126F	012126F	012126F	012126F	012126F	012126F
8-J	Interlock Relay 24V SPDT	N/A	N/A	009039F	009039F	009039F	009039F	009039F
9-J	PC Board Adapter Status Lights Wiring	014712F	014712F	014712F	014712F	014712F	014712F	014712F
10-J	Indicator Lamp	011848F	011848F	011848F	011848F	011848F	011848F	011848F
11-J	Terminal Block w / Ground Lug	008523F	008523F	008523F	008523F	008523F	008523F	008523F
12-J	Stage Control Sequencer 4-20mA	016589F	016590F	N/A	N/A	N/A	N/A	N/A
M MISCELLANEOUS								
1-M	PRV 30 PSI	007748F	007748F	007748F	007748F	008088F	008088F	008088F
	PRV 45 PSI	007221F	007751F	007751F	007752F	007752F	007752F	007752F
	PRV 60 PSI	007222F	007753F	007754F	007754F	007754F	007754F	008288F
	PRV 75 PSI	007223F	007756F	007756F	007756F	007757F	007757F	007757F
	PRV 125 PSI	007224F	007224F	007224F	007758F	007759F	007759F	007759F
	PRV 150 PSI	007225F	007225F	007225F	007225F	007225F	007225F	007225F
2-M	Delimiting Kit	052870F	052870F	052870F	052870F	052870F	052870F	052870F
3-M	T & P Gauge 0-90 PSI	007205F	007205F	007205F	007205F	007205F	007205F	007205F
	T & P Gauge 0-200 PSI	007399F	007399F	007399F	007399F	007399F	007399F	007399F
	T & P Gauge 0-230 PSI	014221F	014221F	014221F	014221F	014221F	014221F	014221F
4-M	RTV Sealant 2.8 oz	008924F	008924F	008924F	008924F	008924F	008924F	008924F
	RTV Sealant 10 oz	005755F	005755F	005755F	005755F	005755F	005755F	005755F
5-M	Sealant Tape (gray) Specify Length	800351	800351	800351	800351	800351	800351	800351
6-M	Fiberfrax Insulation 1" Wide	008406F	008406F	008406F	008405F	008405F	008405F	008405F
7-M	Flue Exhaust Tee Seal Gasket	009690F	009691F	009691F	009692F	009692F	009692F	009693F
8-M	Flue Exhaust Adapter Seal Gasket	009635F	009636F	009636F	009637F	009637F	009637F	009638F
9-M	Intake Air Seal Gaskets (Truseal)	010028F	010028F	010028F	010028F	010028F	010028F	010028F
10-M	Window Combustion Chamber	006947F	006947F	006947F	006947F	006947F	006947F	006947F
11-M	Flame Sensor	006535F	006535F	006535F	006535F	006535F	006535F	006535F
12-M	Igniter	007400F	007400F	007400F	007400F	007400F	007400F	007400F
13-M	Touch-up Paint							
	Green	750125	750125	750125	750125	750125	750125	750125
	Cool Dark Gray	750256	750256	750256	750256	750256	750256	750256
14-M	Sight Window Plug	008474F	008474F	008474F	008474F	008474F	008474F	008474F
15-M	Gas Manifold Grommet 3/4" NPT	010778F	010778F	010778F	010778F	010778F	010778F	010778F
16-M	Gas Manifold Grommet 2" NPT	010780F	010780F	010780F	010780F	010780F	010780F	010780F
17-M	Switch/Decal Membrane	013937F	013937F	013937F	013937F	013937F	013937F	013937F
O OPTIONS								
1-O	Remote Sensor (LWCO)	007228F	007228F	007228F	007228F	007228F	007228F	007228F
2-O	Control PC Board (LWCO)	007157F	007157F	007157F	007157F	007157F	007157F	007157F
3-O	Test / Reset Switch (LWCO)	005641F	005641F	005641F	005641F	005641F	005641F	005641F
4-O	Silencer/Reset Switch (Alarm)	005641F	005641F	005641F	005641F	005641F	005641F	005641F
5-O	Alarm Bell 3"	005642F	005642F	005642F	005642F	005642F	005642F	005642F
	Alarm Bell 4"	005643F	005643F	005643F	005643F	005643F	005643F	005643F
6-O	Relay 3PDT 24 VAC (Alarm)	014717F	014717F	014717F	014717F	014717F	014717F	014717F

* Product with steel rod baffles are for WH water heaters only and manufactured from 4/1/17

CALL OUT	DESCRIPTION	992C	1262C	1532C	1802C	2002C	2072C	2342C
P	PUMPS*							
1-P	Inline Pumps (H & WH)							
	Bronze (Soft Water)	007227F	007227F	011845F	007348F	007348F	007348F	007351F
	Bronze (Medium Water)	011845F	007348F	007351F	007351F	007937F	007937F	007937F
	Bronze (Hard Water)	007348F	007351F	007351F	007937F	007937F	007937F	007937F
	Inline Pumps (H)							
	Cast Iron (Soft Water /Standard)	007233F	007233F	011846F	007354F	007354F	007354F	007357F
	Cast Iron (Medium Water /Alternate 1)	011846F	007354F	007357F	007357F	007938F	007938F	007938F
	Cast Iron (Hard Water /Alternate 2)	007354F	007357F	007357F	007938F	007938F	007938F	007938F
2-P	Integral Return Header Mounted Pump (H & WH)							
	4.0 Impeller	009296F	009296F	N/A	N/A	N/A	N/A	N/A
	4.25 Impeller	004844F	N/A	N/A	N/A	N/A	N/A	N/A
	4.7 Impeller	N/A	N/A	004845F	N/A	N/A	N/A	N/A
	Pumps for (P) Pool Heaters							
	Inline Pumps	N/A	N/A	007348F	007348F	007351F	007351F	007937F
	Integral Return Header Mounted Pump	004845F	004845F	N/A	N/A	N/A	N/A	N/A
3-P	Pump Flange Gasket Taco 1600 Series							
	Gasket Round (2 Bolt)	013423F	013423F	013423F	013423F	013423F	013423F	013423F
	Gasket Flat (2 Bolt)	013423F	013423F	013423F	013423F	013423F	013423F	013423F
	Gasket Flat (4 Bolt)	N/A	N/A	N/A	014000F	014000F	014000F	014000F
R	REFRACTORY							
1-R	Refractory Kit (All Panels)	007760F	007761F	007762F	007763F	007764F	007764F	007765F
2-R	Refractory Front Panels	007766F	007767F	007768F	007769F	007770F	007770F	007771F
3-R	Refractory Blanket	009869F	009870F	009871F	009872F	009873F	009873F	009874F
S	SHEETMETAL							
1-S	Jacket Top	009629F	009630F	009631F	009632F	009633F	009633F	009634F
2-S	Upfront Control Panel w/LCD & Window	016591F	016591F	016591F	016591F	016591F	016591F	016591F
3-S	Upper Control Access Jacket Panel	009645F	009646F	009647F	009648F	009649F	009649F	009650F
4-S	Lower Front Jacket Panel	009651F	009652F	009653F	009654F	009655F	009655F	009656F
5-S	Access Panel Igniter/Sensor	016592F	016592F	016592F	016592F	016592F	016592F	016592F
6-S	Lower Rear Jacket Panel	009657F	009658F	009659F	009660F	009661F	009661F	009662F
7-S	Upper Left Side Jacket Panel	009663F	009663F	009663F	009663F	009663F	009663F	009663F
8-S	Upper Right Side Jacket Panel	009695F	009695F	009695F	009695F	009695F	009695F	009695F
9-S	Air Intake Cover Panel	009696F	009696F	009696F	009696F	009696F	009696F	009696F
10-S	Rear Flue Exhaust Cover Panel	009664F	009665F	009665F	009666F	009666F	009666F	009667F
11-S	Flue Exhaust Cover Panel	009713F	009714F	009714F	009715F	009715F	009715F	009716F
12-S	Lower Corner Supports Front and Rear	009668F	009668F	009668F	009668F	009668F	009668F	009668F
13-S	Center Support Panel	010237F	010238F	010239F	010240F	010241F	010241F	010243F
14-S	Left & Right Heat Exchanger Support	010244F	010244F	010244F	010244F	010244F	010244F	010244F
15-S	Intake Air Distribution Box (Truseal)	009669F	009669F	010789F	010789F	009670F	009670F	009670F
16-S	Support Horizontal	009671F	009672F	009673F	009674F	009675F	009675F	009676F
17-S	Support Assy Controls and Flue Exhaust	009677F	009677F	009677F	009677F	009677F	009677F	009677F
18-S	Flue Collector Top	009678F	009679F	009680F	009681F	009682F	009682F	009683F
19-S	Access Panel	009684F	009684F	009684F	009684F	009684F	009684F	009684F
20-S	Access Panel w/Pump	009685F	009685F	009685F	009685F	009685F	009685F	009685F
21-S	Cover for Integral Return Header Mounted Pump	002671F	002671F	002671F	002671F	002671F	002671F	002671F
22-S	Control Box Sheetmetal	016593F	016593F	016593F	016593F	016593F	016593F	016593F
23-S	Field Wiring/Display Mounting Panel	016594F	016594F	016594F	016594F	016594F	016594F	016594F
24-S	Filter Mounting Panel	009699F	009699F	009699F	009699F	009699F	009699F	009699F
25-S	Intake Air Vent Hood	010747F	010747F	010747F	010747F	010747F	010747F	010747F
26-S	Flue Exhaust Gasket Retainer	010032F	010033F	010033F	010034F	010034F	010034F	010035F
27-S	Combustion Chamber Rear Panel	010772F	010773F	010774F	010775F	010776F	010776F	010777F
28-S	Base Assy	010760F	010761F	010762F	010763F	010764F	010764F	010765F
29-S	Rear Center Cover Panel	011859F	011859F	011859F	011859F	011859F	011859F	011859F
30-S	Power In/Dry Contacts Panel	016484F	016484F	016484F	016484F	016484F	016484F	016484F
31-S	Switch Mtg Panel	012343F	012343F	012343F	012343F	012343F	012343F	012343F
V	VENTING							
1-V	Outdoor Stack	014552F	014553F	014553F	014649F	014649F	014649F	015447F
2-V	Flue Exhaust Tee	009701F	009702F	009702F	009703F	009703F	009703F	009704F
3-V	Flue Exhaust Tee Cap	009705F	009706F	009706F	009707F	009707F	009707F	009708F
4-V	Flue Exhaust Adapter	009709F	009710F	009710F	009711F	009711F	009711F	009712F
5-V	Flue Exhaust Straight Pipe	011854F	011855F	011855F	011856F	011856F	011856F	011857F

* For individual pump parts see separate pump parts IPL 9300.100

CALL OUT	DESCRIPTION	992C	1262C	1532C	1802C	2002C	2072C	2342C
W	WIRING							
1-W	Wire Harnesses							
	Diagnostic Panel Ribbon Cable 16 PIN	016485F	016485F	016485F	016485F	016485F	016485F	016485F
	Diagnostic Panel Ribbon Cable 10 PIN	016486F	016486F	016486F	016486F	016486F	016486F	016486F
	Bell & Alarm Wire Harness	016487F	016487F	016630F	016630F	016630F	016630F	016630F
	Gas Valve Wire Harness (Honeywell)	015896F	015896F	015896F	015896F	015896F	015896F	015896F
	Gas Valve /Safety Board 24V Wire Harness	016595F	016596F	016597F	016597F	016598F	016598F	016598F
	Gas Valve /Safety Board 24V Left Side Wire Harness	016599F	016600F	016600F	016600F	016601F	016601F	016601F
	Gas Valve /Safety Board 24V Right Side Wire Harness	016602F	016602F	016603F	016603F	016604F	016604F	016604F
	PIM HSI/Blower Wire Harness	016605F	016605F	016606F	016606F	016607F	016607F	016607F
	PIM HSI/Blower Left Side Wire Harness	016608F	016608F	016608F	016608F	016609F	016609F	016609F
	PIM HSI/Blower Right Side Wire Harness	N/A	N/A	016610F	016610F	016611F	016611F	016611F
	PIM 120V Power W/Pump Wire Harness	016497F	016497F	016497F	016497F	016497F	016497F	016497F
	PIM 120V Power No Pump Wire Harness	N/A	N/A	016612F	016612F	016612F	016612F	016612F
	PIM to Pim Wire Harness	N/A	N/A	016613F	016613F	016613F	016613F	016613F
	Interlock Relay Wire Harness	N/A	N/A	016614F	016614F	016614F	016614F	016614F
	PIM 1 Power 24V Wire Harness	016498F	016498F	016498F	016498F	016498F	016498F	016498F
	PIM 2 Power 24V Wire Harness	N/A	N/A	016615F	016615F	016615F	016615F	016615F
	Power In Wire Harness	016499F	016499F	016499F	016499F	016499F	016499F	016499F
	In/Out Sensor J-Box Wire Harness	016500F	016500F	016500F	016500F	016500F	016500F	016500F
	In/Out Sensor Cabinet Wire Harness	016502F	016502F	016502F	016502F	016502F	016502F	016502F
	Control Box 120V Wire Harness	016503F	016503F	016503F	016503F	016503F	016503F	016503F
	Versa IC Communication Cable	015556F	015556F	015556F	015556F	015556F	015556F	015556F
	Heater ID Wire Harness	016504F	016504F	016504F	016504F	016504F	016504F	016504F
	Field Wiring Terminal Block 1 Wire Harness	016505F	016505F	016505F	016505F	016505F	016505F	016505F
	Field Wiring Terminal Block 2 Wire Harness	016506F	016506F	016506F	016506F	016506F	016506F	016506F
	Control Signal Splitter Wire Harness	016507F	016507F	016507F	016507F	016507F	016507F	016507F
	High Limit Manual Adjustable Wire Harness	016508F	016508F	016508F	016508F	016508F	016508F	016508F
	High Limit Auto Adjustable Wire Harness	016509F	016509F	016509F	016509F	016509F	016509F	016509F
	Pump Power 120V Wire Harness	016510F	016510F	N/A	N/A	N/A	N/A	N/A
	Low Water Cut Off Wire Harness	016511F	016511F	016511F	016511F	016511F	016511F	016511F
	High Gas Pressure Switch Wire Harness	016513F	016513F	016616F	016616F	016616F	016616F	016616F

Gas valve usage - NATURAL GAS

MODEL NUMBER	RISER				
	GV1	GV1A	GV2	GV3	GV4
992	007666F	N/A	007666F	See 6-G	N/A
1262	007666F	N/A	007424F	007666F	See 6-G
1532	007666F	N/A	007424F	007424F	007424F
1802	007666F	N/A	007424F	007666F	007666F
2002 & 2072	007424F	007666F	007666F	007666F	007424F
2342	007666F	007666F	007666F	007666F	007666F

Gas valve usage - PROPANE (Honeywell Gas Valve)**

MODEL NUMBER	RISER				
	GV1	GV1A	GV2	GV3	GV4
992	007425F	N/A	007425F	See 6-G	N/A
1262	007425F	N/A	007425F	007425F	See 6-G
1532	007425F	N/A	007425F	007425F	007425F
1802	007425F	N/A	007425F	007425F	007425F
2002*	N/A	N/A	N/A	N/A	N/A
2072	007425F	007425F	007425F	007425F	007425F
2342	007425F	007425F	007425F	007425F	007425F

* Propane is not supported on the 2002C size.

**For Units with Robertshaw gas valve use kit number 007667F in lieu of 007425F.

9. WARRANTY

Types H and WH



LIMITED PARTS WARRANTY HI DELTA – TYPES H AND WH MODELS 992C–2342C

SCOPE

Raypak, Inc. ("Raypak") warrants to the original owner that all parts of this heater which are actually manufactured by Raypak will be free from failure under normal use and service for the specified warranty periods and subject to the conditions set forth in this Warranty. Labor charges and other costs for parts removal or reinstallation, shipping and transportation are not covered by this Warranty but are the owner's responsibility.

HEAT EXCHANGER WARRANTY

Domestic Hot Water

Five (5) years from date of heater installation. Includes copper heat exchanger with bronze waterways.

Ten (10) years from date of heater installation. Includes only cupronickel heat exchanger with bronze waterways.

Space Heating (Closed Loop System)

Ten (10) years from date of heater installation. Includes both cupronickel and copper heat exchanger with bronze or cast iron waterways.

Thermal Shock Warranty

Twenty (20) years from date of heater installation against "Thermal Shock" (excluded, however, if caused by heater operation at large changes exceeding 150°F between the water temperature at intake and heater temperature, or operating at heater temperatures exceeding 230°F).

ANY OTHER PART MANUFACTURED BY RAYPAK

One (1) year warranty from date of heater installation, or eighteen (18) months from date of factory shipment based on Raypak's records, whichever comes first.

SATISFACTORY PROOF OF INSTALLATION DATE, SUCH AS INSTALLER INVOICE, IS REQUIRED. THIS WARRANTY WILL BE VOID IF THE HEATER RATING PLATE IS ALTERED OR REMOVED.

ADDITIONAL WARRANTY EXCLUSIONS

This warranty does not cover failures or malfunctions resulting from:

1. Failure to properly install, operate or maintain the heater in accordance with our printed instructions provided;
2. Abuse, alteration, accident, fire, flood and the like;
3. Sediment or lime build-up, freezing, or other conditions causing inadequate water circulation;
4. High velocity flow exceeding heater design rates;
5. Failure of connected systems devices, such as pump or controller;
6. Use of non-factory authorized accessories or other components in conjunction with the heater system;
7. Failing to eliminate air from, or replenish water in, the connected water system;
8. Chemical contamination of combustion air or use of chemical additives to water.

PARTS REPLACEMENT

Under this Warranty, Raypak will furnish a replacement for any failed part. The failed part must first be returned to Raypak if requested, with transportation charges prepaid, and all applicable warranty conditions found satisfied. The replacement part will be warranted for only the unexpired portion of the original warranty. Raypak makes no warranty whatsoever on parts not manufactured by it, but Raypak will apply any such warranty as may be provided to it by the parts manufacturer.

TO MAKE WARRANTY CLAIM

Promptly notify the original installer, supplying the model and serial numbers of the unit, date of installation and description of the problem. The installer must then notify his Raypak distributor for instructions regarding the claim. If either is not available, contact Service Manager, Raypak, Inc., 2151 Eastman Avenue, Oxnard, CA 93030 or call (805) 278-5300. In all cases proper authorization must first be received from Raypak before replacement of any part.

EXCLUSIVE WARRANTY - LIMITATION OF LIABILITY

This is the only warranty given by Raypak. No one is authorized to make any other warranties on Raypak's behalf. THIS WARRANTY IN LIEU OF ALL OTHER WARRANTIES, EXPRESS OR IMPLIED, INCLUDING BUT NOT LIMITED TO IMPLIED WARRANTIES OF MERCHANTABILITY AND FITNESS FOR A PARTICULAR PURPOSE. RAYPAK'S SOLE LIABILITY AND THE SOLE REMEDY AGAINST RAYPAK WITH RESPECT TO DEFECTIVE PARTS SHALL BE AS PROVIDED IN THIS WARRANTY. IT IS AGREED THAT RAYPAK SHALL HAVE NO LIABILITY, WHETHER UNDER THIS WARRANTY, OR IN CONTRACT, TORT, NEGLIGENCE OR OTHERWISE, FOR ANY SPECIAL, CONSEQUENTIAL, OR INCIDENTAL DAMAGE, INCLUDING DAMAGE FROM WATER LEAKAGE. Some states do not allow limitations on how long an implied warranty lasts, or for the exclusion of incidental or consequential damages. So the above limitation or exclusion may not apply to you.

This Limited Warranty gives you specific legal rights. You may also have other rights which may vary from state to state. We suggest that you complete the information below and retain this certificate in the event warranty service is needed. Reasonable proof of the effective date of the warranty (date of installation) must be presented, otherwise, the effective date will be based on the rate of manufacture plus thirty (30) days.

Original Owner _____	Model Number _____
Mailing Address _____	Serial Number _____
_____	Date of Installation _____
City _____ State _____ Zip Code _____	Installation Site _____
Daytime Telephone Number _____	Contractor/Installer _____

RAYPAK, INC • 2151 Eastman Avenue • Oxnard, CA 93030-9786 • (805) 278-5300 • Fax (800) 872-9725 • www.raypak.com

Type P

LIMITED WARRANTY HI DELTA PROFESSIONAL SERIES POOL HEATER Models: P0502C thru P2342C

SCOPE OF WARRANTY

Raypak, Inc. (Raypak) warrants to the original owner that the above model gas pool and spa heater (the "Heater") when installed in the 50 states of the United States of America with a pool or spa by a properly licensed installer will be free from defects in materials and workmanship under normal use and service for the Applicable Warranty Period. Under this Limited Warranty, Raypak will, at its option, repair or furnish a replacement for any defective part of the HEATER. The repair or replacement will be warranted for only the unexpired portion of the original Applicable Warranty Period.

EFFECTIVE DATE

The Effective Date of Warranty coverage is the date of original installation if properly documented; otherwise it is the date of manufacture plus 30 days. All Applicable Warranty Periods specified in this Limited Warranty are measured from the Effective Date.

APPLICABLE WARRANTY PERIOD

If the HEATER is installed with a pool or spa, the Applicable Warranty Period is one (1) year from the Effective Date, parts and labor, for the HEATER and component parts, except that the cupronickel heat exchanger will have an Applicable Warranty Period of five (5) years from the Effective Date, with no labor coverage in the second thru fifth years.

LABOR AND SHIPPING COSTS

This Limited Warranty covers the reasonable cost of labor for repairs or replacements covered by this Limited Warranty up to \$1000 per heater, provided that said repairs or replacements are performed by a Raypak designated service provider during the Applicable Warranty Period and Raypak has pre-authorized said repair or replacement. This Limited Warranty does not cover any travel time or other labor costs. Furthermore, this Limited Warranty does not cover any shipping costs to and from the service provider or to or from the installation site. All of the foregoing costs and expenses are your responsibility.

WARRANTY EXCLUSIONS

This Limited Warranty does **NOT** apply;

1. if the Heater has been moved from its original place of installation, or if the original owner no longer owns the property where the original installation was made;
2. if the Heater is not properly installed with a pool or spa by a qualified licensed installer in accordance with applicable local codes and ordinances, good trade practices, and the manufacturer's installation instructions. Not to be installed in a closed loop hydronic heating, or potable water heating application;
3. if the rating plate(s) or serial number(s) are altered or removed;
4. if the Heater is modified in any way, or non-factory authorized accessories or other components are used in conjunction with the Heater;
5. to damage, malfunctions or failures resulting from failure to properly install, operate or maintain the Heater in accordance with the manufacturer's instructions;
6. to damage, malfunctions or failures resulting from abuse, act of nature, accident, fire, flood, freeze, lightning or the like;
7. to damage, malfunctions or failures resulting from connected system control devices;
8. performance problems caused by improper sizing of the Heater or electric service voltage, wiring or fusing;
9. use of any attachment, including without limitation, any energy saving device not authorized by the manufacturer;
10. to damage, malfunctions or failures resulting from misuse or neglect, including but not limited to, freeze-ups, operating the Heater with the cabinet door off, having flow restrictions or obstructions between the Heater outlet and the pool/spa, electrolysis due to an improperly installed salt chlorine generator, or not maintaining a proper chemical balance (PH level must be between 7.4 and 7.8 and total alkalinity between 100 and 150 PPM. Total dissolved solids (TDS) must be no greater than 3000 PPM. In salt water chlorinated pools, TDS must be no greater than 6000 PPM).

HOW TO MAKE A WARRANTY CLAIM

You should immediately notify your dealer and provide proof of purchase model number serial number and date of installation. Your dealer will contact Raypak for instructions regarding the claim and to determine the location of the nearest authorized service center. If the dealer is not available, please contact Raypak warranty service at 805-278-5300. When making a claim please be ready to supply the model number, serial number, date of original installation and a description of the problem. **Proper authorization MUST be obtained PRIOR to any repairs for the Limited Warranty to apply. This Limited Warranty is VOID if the Heater is repaired or altered in any way by ANY persons or agencies other than those authorized by Raypak.** Raypak reserves the right at all times to inspect, or require the return of, the defective Heater or component part and to verify warranty coverage at its factory.

EXCLUSIVE WARRANTY-LIMITATION OF LIABILITY

THE LIMITED WARRANTY IS THE ONLY WARRANTY GIVEN BY RAYPAK IN CONNECTION WITH THE HEATER AND ITS COMPONENT PARTS. NO ONE IS AUTHORIZED TO MAKE ANY OTHER WARRANTIES ON RAYPAK’S BEHALF. ANY IMPLIED WARRANTIES, INCLUDING MERCHANTABILITY OR FITNESS FOR A PARTICULAR PURPOSE, SHALL NOT EXTEND BEYOND THE APPLICABLE WARRANTY PERIOD SPECIFIED ABOVE. RAYPAK’S SOLE LIABILITY WITH RESPECT TO ANY DEFECT SHALL BE AS SET FORTH IN THIS LIMITED WARRANTY. IT IS AGREED THAT RAYPAK SHALL HAVE NO LIABILITY WHETHER UNDER THIS LIMITED WARRANTY OR IN CONTRACT, TORT OR NEGLIGENCE OR OTHERWISE FOR CLAIMS FOR SPECIAL, INCIDENTAL OR CONSEQUENTIAL DAMAGES (INCLUDING NO LIABILITY FOR DAMAGE FROM WATER LEAKAGE), ALL OF WHICH ARE EXPRESSLY EXCLUDED. SOME STATES DO NOT ALLOW LIMITATIONS ON HOW LONG AN IMPLIED WARRANTY LASTS, OR FOR THE EXCLUSION OF INCIDENTAL OR CONSEQUENTIAL DAMAGES, SO THE ABOVE LIMITATION OR EXCLUSION MAY NOT APPLY TO YOU.

THIS LIMITED WARRANTY GIVES YOU SPECIFIC LEGAL RIGHTS, AND YOU MAY ALSO HAVE OTHER RIGHTS WHICH VARY FROM STATE TO STATE.

We suggest you immediately record the model and serial number and date of original installation and retain this Limited Warranty Certificate in the event warranty service is needed.

DO NOT RETURN THIS DOCUMENT TO RAYPAK. KEEP IT WITH YOUR POOL HEATER OR BUSINESS RECORDS.

Name of Owner	Name of Installer
Owners Address	Installers Address
Date of Pool Heater Installation	Telephone Number of Installer
Model Number of Your Pool Heater	Serial Number of Your Pool Heater

RAYPAK, INC., 2151 Eastman Avenue, Oxnard, CA 93030 • (805) 278-5300 FAX (800) 872-9725

p/n 241640

Start-up Check List

Start-up checklist for fan-assisted Raypak products.

This start-up checklist is to be completely filled out by the service technician starting up the Raypak Boiler or Heater for the first time. All information may be used for warranty purposes and to ensure that the installation is correct. Additionally this form will be used to record all equipment operation functions and required settings.

GAS SUPPLY DATA

Regulator Model & Size _____ / _____ CFH
 Gas Line Size (in room) _____ In. NPT
 Length of Gas Line _____ Eq Ft
 Low Gas Pressure Setting _____ In. WC
 High Gas Pressure Setting _____ In. WC
 Gas Shutoff Valve Type _____
 (Ball, Lube cock)
 Sediment Trap _____ Y/N
 Port _____ Std _____ Full

VISUAL INSPECTION OF COMPONENTS

Verify inspection was done and condition of components are in good working order with a "yes"

Wiring Harness _____ Y/N
 Burner/s (flame) _____ Y/N
 Refractory (visual) _____ Y/N
 Remote flame sense _____ Y/N
 Covers in place for outdoor _____ Y/N

VENTING

Vent Size: _____ Stack Height: _____
 Category: _____ sketch vent on reverse side ***
 Vent Material: _____
 Vent Termination Type: _____
 Combustion Air Openings: Low _____ in2
 Ventilation air High _____ in2

EMISSIONS SETTINGS AND TEST INFORMATION (AT FULL FIRE)

Blower Pressure Setting _____ In. WC
 Supply Gas Pressure _____ In. WC
 Verify stable pressure static & dynamic condition
 Pilot Gas Pressure _____ In. WC
 Manifold Gas Pressure _____ In. WC

The following measurements must be obtained with a Combustion Analyzer.

NOX _____ PPM
 Free Oxygen _____ %
 CO _____ PPM
 CO2 _____ %

Model Number: _____
 *** Note: draw venting with details, such as extractors, barometric dampers, blast dampers or draft inducers

CLEARANCES

Front Clearance _____ In.
 Right Side Clearance _____ In.
 Left Side Clearance _____ In.
 Rear Clearance _____ In.
 Overhead Clearance _____ In.

ELECTRICAL

Voltage Supply (VAC) No Load _____ Load _____
 Voltage -24 VAC _____ VAC
 Voltage Com to Ground _____ VAC
 Hot Surface Igniter _____ Ohms
 Auto High Limit Setting _____ deg F
 Manual Reset High Limit Setting _____ deg F
 Operating Control Setting _____ deg F

Sketch plumbing on reverse side

WATER SUPPLY

Flow Rate in GPM or Delta T _____ If Avail
Measure flow rate at full fire
 Pump Economaster setting _____ Minutes
 Low Water Cutoff _____ Test
 Number of Tanks and Size Qty _____ Gallons
 Plumbing Size _____
 Pump Size: _____ (boiler) Pump HP: _____
 Impeller trim _____ Pump Model _____
 Louvers _____ Screens _____

Nominal Factory Recommended Settings

See manual or card tag
 See manual or card tag
 See manual or card tag
 See manual or card tag

Job Name _____

Address _____

Physical Location of Boiler: Indoors _____; Outdoors _____; Ground Level _____; Roof _____; Below Grade _____

Mechanical Contractor / Installer _____

Date and Time of Start-up _____ Print Name and Signature of Start-up Technician _____

Information must be faxed to: (805) 278-5496 in order to ensure warranty consideration Attn: Service Manager

Important Instructions for the Commonwealth of Massachusetts

The Commonwealth of Massachusetts requires compliance with regulation 248 CMR 4.00 and 5.00 for installation of through – the – wall vented gas appliances as follows:

(a) For all side wall horizontally vented gas fueled equipment installed in every dwelling, building or structure used in whole or in part for residential purposes, including those owned or operated by the Commonwealth and where the side wall exhaust vent termination is less than seven (7) feet above finished grade in the area of the venting, including but not limited to decks and porches, the following requirements shall be satisfied:

1. INSTALLATION OF CARBON MONOXIDE DETECTORS. At the time of installation of the side wall horizontal vented gas fueled equipment, the installing plumber or gasfitter shall observe that a hard wired carbon monoxide detector with an alarm and battery back-up is installed on the floor level where the gas equipment is to be installed. In addition, the installing plumber or gasfitter shall observe that a battery operated or hard wired carbon monoxide detector with an alarm is installed on each additional level of the dwelling, building or structure served by the side wall horizontal vented gas fueled equipment. It shall be the responsibility of the property owner to secure the services of qualified licensed professionals for the installation of hard wired carbon monoxide detectors

a. In the event that the side wall horizontally vented gas fueled equipment is installed in a crawl space or an attic, the hard wired carbon monoxide detector with alarm and battery back-up may be installed on the next adjacent floor level.

b. In the event that the requirements of this subdivision can not be met at the time of completion of installation, the owner shall have a period of thirty (30) days to comply with the above requirements; provided, however, that during said thirty (30) day period, a battery operated carbon monoxide detector with an alarm shall be installed.

2. APPROVED CARBON MONOXIDE DETECTORS. Each carbon monoxide detector as required in accordance with the above provisions shall comply with NFPA 720 and be ANSI/UL 2034 listed and IAS certified.

3. SIGNAGE. A metal or plastic identification plate shall be permanently mounted to the exterior of the building at a minimum height of eight (8) feet above grade directly in line with the exhaust vent terminal for the horizontally vented gas fueled heating appliance or equipment. The sign shall read, in print size no less than one-half (1/2) inch in size, "GAS VENT DIRECTLY BELOW. KEEP CLEAR OF ALL OBSTRUCTIONS".

4. INSPECTION. The state or local gas inspector of the side wall horizontally vented gas fueled equipment shall not approve the installation unless, upon inspection, the inspector observes carbon monoxide detectors and signage installed in accordance with the provisions of 248 CMR 5.08(2)(a)1 through 4.

(b) **EXEMPTIONS:** The following equipment is exempt from 248 CMR 5.08(2)(a)1 through 4:

1. The equipment listed in Chapter 10 entitled "Equipment Not Required To Be Vented" in the most current edition of NFPA 54 as adopted by the Board; and

2. Product Approved side wall horizontally vented gas fueled equipment installed in a room or structure separate from the dwelling, building or structure used in whole or in part for residential purposes.

(c) **MANUFACTURER REQUIREMENTS - GAS EQUIPMENT VENTING SYSTEM PROVIDED.** When the manufacturer of Product Approved side wall horizontally vented gas equipment provides a venting system design or venting system components with the equipment, the instructions provided by the manufacturer for installation of the equipment and the venting system shall include:

1. Detailed instructions for the installation of the venting system design or the venting system components; and

2. A complete parts list for the venting system design or venting system.

(d) **MANUFACTURER REQUIREMENTS - GAS EQUIPMENT VENTING SYSTEM NOT PROVIDED.** When the manufacturer of a Product Approved side wall horizontally vented gas fueled equipment does not provide the parts for venting the flue gases, but identifies "special venting systems", the following requirements shall be satisfied by the manufacturer:

1. The referenced "special venting system" instructions shall be included with the appliance or equipment installation instructions; and

2. The "special venting systems" shall be Product Approved by the Board, and the instructions for that system shall include a parts list and detailed installation instructions.

(e) A copy of all installation instructions for all Product Approved side wall horizontally vented gas fueled equipment, all venting instructions, all parts lists for venting instructions, and/or all venting design instructions shall remain with the appliance or equipment at the completion of the installation.

GAS PRESSURE SUPERVISION

The Commonwealth of Massachusetts requires listed high and low gas pressure switches (manual-reset) for any model with a maximum firing input greater than 1,000,000 Btu/Hr in accordance with 248 CMR 7.04(11)(d).

A gas pressure regulator (field-supplied) is required in the gas train ahead of the heater, for heaters having input rates greater than 1,000,000 Btu/Hr, in accordance with 248 CMR 7.04 Figure 3B requirements.

Notes



ISO 9001

REGISTERED QUALITY MANAGEMENT SYSTEM

www.raypak.com