

Job: _____
 Engineer: _____
 Contractor: _____
 Prepared By: _____ Date: _____
 Model: _____ Indoor/Outdoor: _____

ADB™ - Type H

Hydronic Heating Boilers

Models 751-1501

100% Factory Fire Tested

Efficiency: 84%

Maximum Outlet Temperature: 230°F

Minimum Non-Condensing Inlet Temperature: 105°F

Thermal Shock Proof Heat Exchanger

Footprint: Less Than 5-1/2 ft²

Limited Twenty-Year Thermal Shock Warranty

Limited Ten-Year Heat Exchanger Warranty

Ten-Year Unconditional Burner Head Warranty

Operation Status Center and Full Diagnostic Panel

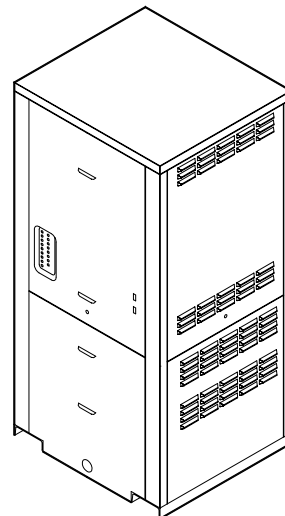

Heat Exchanger

- Bronze Headers
- ASME Inspected and Stamped
160 PSIG Working Pressure
- National Board Approved
- Copper-finned Tubes
- ASME Steel Tube Retainer
- Silicone High Temp O-Rings
- 60 PSIG ASME Pressure Relief Valve
- Temperature and Pressure Gauge, Shipped Loose

Control

- 120V, 60Hz, Power Supply
- 120/24V 60Hz Transformer
- 100% Pilot Shutoff/Lockout
- Electronic Intermittent Ignition Pilot (IID)
- High Limit Control, Manual Reset
- High Limit Control, Auto Reset
- On/Off Switch
- Flow Switch
- Blocked Vent Pressure Switch
- Combustion Air Proving Switch
- Time Delay Pump Off Control
- Central Point Wiring Diagnostics Panel

Burner

- Aerodynamically Stabilized Non-Clog Burner
- Ultra-Low NOx: Less than 30 PPM

Gas Train

- Fuel
 - Natural Gas
 - Propane (Models 751 & 1001)
- Manual Gas Shut-off Valves
- Gas Pressure Regulator
- Safety Shut-off Valve
- Firing Control Valve
- Manual Low Gas Pressure Switch
- On/Off Firing Mode (H4)
- Design Certified ANSI Z21.13/ CSA 4.9

Construction

- Indoor/Outdoor Construction
- Front Controls Enclosed
- PolyTuf Powder Coat Finish
- Connections (Water, Electrical, Gas)
 - Rear – Standard
 - Right Side – Option A-8

Venting

- Vent Location
 - Rear – Standard
 - Right Side – Option Z-2
- Vent Termination Cap
 - Outdoor - Option D-11
 - Indoor, Horizontal – Option D-15
 - Indoor, Vertical (by others)

Temperature Controls

- B-20 Single-Stage Controller, 100-200°F
- B-6 2-Stage Controller, 100-200°F
- B-21 4-Stage TempTracker Digital Controller, Loose
- B-23 4-Stage TempTracker Digital Controller, Outdoor Reset, Loose
- Y-241 Electronic Sequencer, 1-4 Stages
- Y-281 Electronic Sequencer, 5-8 Stages

Additional Safety Controls (Optional)

- F-10 Low Water Cut-off, Remote Probe
- S-2 Manual High Gas Pressure Switch
- _____
- _____

Regulatory Agency Requirements

- C-5 Ignition Lockout Module
- _____

Other Equipment

- Condensing Heat Exchanger
- Pump



Raypak®
A Rheem® Company

ADB – Type H Models 751-1501

Model _____

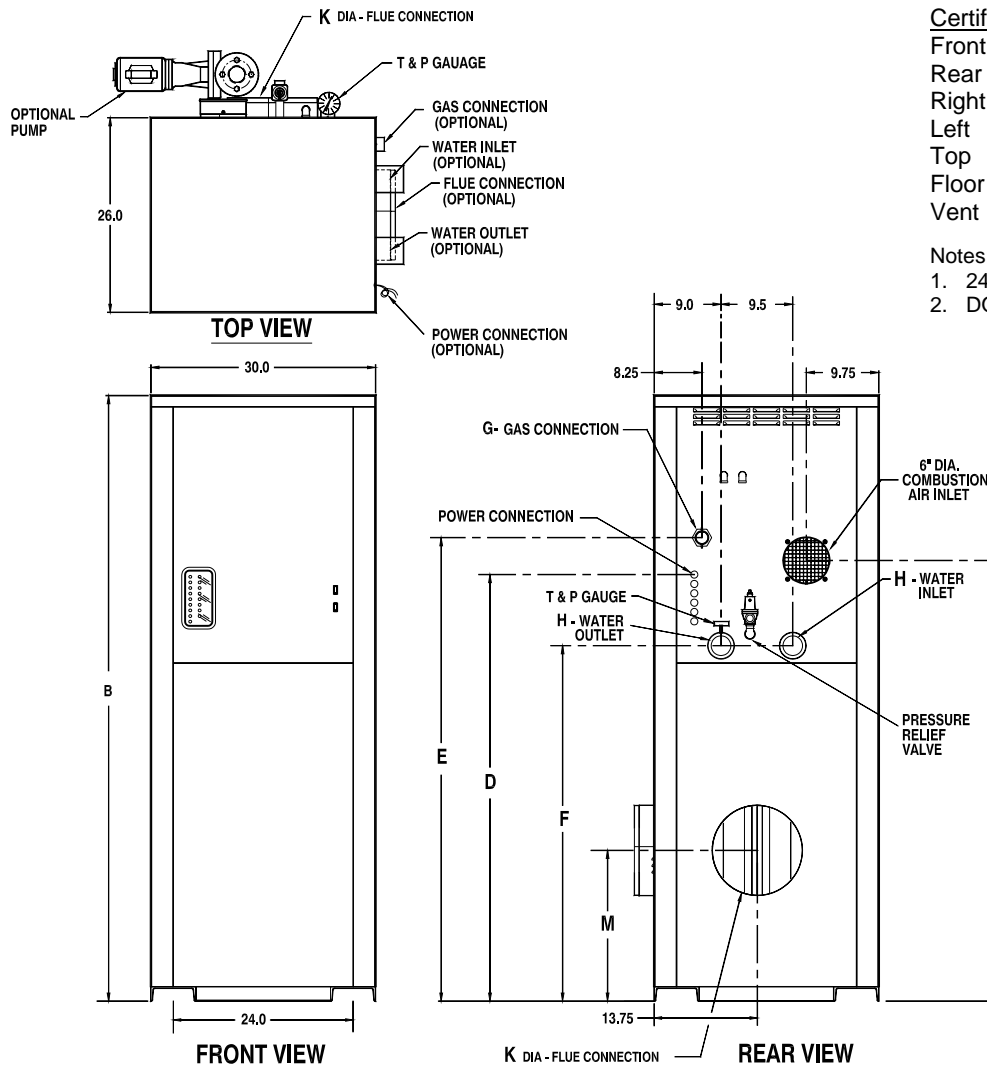

Certified Clearances

Front	24" (for service)
Rear	12" (water side)
Right	1"
Left	1"
Top	0" (see note 1)
Floor	0" (see note 2)
Vent	1"

Notes:

1. 24" required for service
2. DO NOT install on carpeting

Model	MBTUH		B Height	D	E	F	G NPT	H NPT	K Flue Ø	M	P	Ship Weight (Lbs.)	Foot- print (Ft ²)	Amps*
	Input	Output												
H 751	750	630	64	38	44-1/2	29-3/4	1-1/2	2	8	17-3/4	41	680	5.4	8
H 1001	999	840	72	46	52-1/2	37-3/4	1-1/2	2-1/2	10	21-1/2	49	720	5.4	10
H 1501	1499	1260	82	56	62-1/2	47-3/4	1-1/2	2-1/2	12	20-1/4	59	780	5.4	12

- Dimensions are in inches.
- Ratings shown are for elevations up to 5,000 feet. For installations at elevations above 5,000 feet, please consult the factory for additional instructions.
- For direct vent applications, please contact the factory about relocating the pump.

* Current draw does NOT include pump.
(Supply breaker must have delayed trip.)

RATES OF FLOW AND PRESSURE DROPS

Model	20°F ΔT		30°F ΔT		40°F ΔT		Maximum Flow			Minimum Flow		
	GPM	ΔP (ft.)	GPM	ΔP (ft.)	GPM	ΔP (ft.)	GPM	ΔP (ft.)	ΔT (°F)	GPM	ΔP (ft.)	ΔT (°F)
H 751	63	5.8	42	2.9	32	1.8	110	17.0	11	32	1.8	40
H 1001	84	11.8	56	5.6	42	3.4	110	20.0	15	42	3.4	40
H 1501	126	31.4	84	14.9	63	9.1	126	31.4	20	63	9.1	40