

APPROVED

INSTALLATION & OPERATING INSTRUCTIONS



**Models 399B–2339B
Types H & WH**



WARNING: If these instructions are not followed exactly, a fire or explosion may result causing property damage, personal injury or death.

FOR YOUR SAFETY: Do not store or use gasoline or other flammable vapors and liquids or other combustible materials in the vicinity of this or any other appliance. To do so may result in an explosion or fire.

WHAT TO DO IF YOU SMELL GAS:

- Do not try to light any appliance.
- Do not touch any electrical switch; do not use any phone in your building.
- Immediately call your gas supplier from a neighbor's phone. Follow the gas supplier's instructions.
- If you cannot reach your gas supplier, call the fire department.

Installation and service must be performed by a qualified installer, service agency or the gas supplier.

This manual should be maintained in legible condition and kept adjacent to the heater or in another safe place for future reference.

Raypak[®]
A Rheem[®] Company

APPROVED

Revision 5 reflects the following changes:

Note added to "Termination" section on page 31 for vent and intake pipe material certified standards.

Updated the "Horizontal Through-the-Wall Venting (Category III) Installation" section adding a third point on page 31.

Updated the "Periodically" section point number 3 on page 47.

UNCONTROLLED DOCUMENT IF PRINTED

CONTENTS

WARNINGS	4	APPENDIX	49
BEFORE INSTALLATION	5	Inside Air Contamination	49
Product Receipt	5	WARRANTY	50
Model Identification	5	START-UP CHECKLIST	51
Ratings and Certifications	5		
Installations at Elevation	5		
Component Locations	6		
General Information	7		
GENERAL SAFETY	8		
Time/Temperature Relationships in Scalds	8		
INSTALLATION	9		
Installation Codes	9		
Equipment Base	9		
Stacking	9		
Clearances	11		
Combustion and Ventilation Air	12		
Conventional Combustion			
Air Supply	12		
Water Piping	14		
Hydronic Heating	16		
Gas Supply	18		
Electrical Power Connections	21		
Field Wiring Connection	22		
Venting	25		
Changing the Flue Outlet	27		
Venting Installation Tips	27		
Venting Configurations	28		
Outdoor Installation	32		
Controls	32		
Heater Sequence of Operation	33		
Wiring Diagrams	39		
START-UP	41		
Pre Start-up	41		
Start-Up	42		
OPERATION	45		
Lighting Instructions	45		
To Turn Off Gas To Appliance	45		
TROUBLESHOOTING	46		
MAINTENANCE	47		
Suggested Minimum			
Maintenance Schedule	47		
Preventive Maintenance Schedule	47		

WARNINGS

Pay Attention to These Terms

DANGER:	Indicates the presence of immediate hazards which will cause severe personal injury, death or substantial property damage if ignored.
WARNING:	Indicates the presence of hazards or unsafe practices which could cause severe personal injury, death or substantial property damage if ignored.
CAUTION:	Indicates the presence of hazards or unsafe practices which could cause minor personal injury or product or property damage if ignored.
NOTE:	Indicates special instructions on installation, operation, or maintenance which are important but not related to personal injury hazards.

DANGER: Make sure the gas on which the heater will operate is the specified on the heater rating plate.

WARNING: Should overheating occur or the gas supply valve fail to shut, do not turn off or disconnect the electrical supply to the heater. Instead, shut off the gas supply at a location external to the heater.

WARNING - CALIFORNIA PROPOSITION 65: This product contains chemicals known to the State of California to cause cancer, birth defects or other reproductive harm.

WARNING: This unit contains refractory ceramic fiber (RCF) insulation in the combustion chamber. RCF, as manufactured, does not contain respirable crystalline silica. However, following sustained exposure to very high temperatures (>2192F), the RCF can transform into crystalline silica (cristabolite). The International Agency for Research on Cancer (IARC) has classified the inhalation of crystalline silica (cristabolite) as carcinogenic to humans.

When removing the burners or heat exchangers, take precautions to avoid creating airborne dust and avoid inhaling airborne fibers. When cleaning spills, use wet sweeping or High Efficiency Particulate Air (HEPA) filtered vacuum to minimize airborne dust. Use feasible engineering controls such as local exhaust ventilation or dust collecting systems to minimize airborne dust. Wear appropriate personal protective equipment including gloves, safety glasses with side shields, and appropriate NIOSH certified respiratory protection, to avoid inhalation of airborne dust and airborne fiber particles.

WARNING: Do not use this heater if any part has been under water. Immediately call a qualified service technician to inspect the heater and to replace any part of the control system and any gas control which has been under water.

WARNING: To minimize the possibility of improper operation, serious personal injury, fire, or damage to the heater:

- Always keep the area around the heater free of combustible materials, gasoline, and other flammable liquids and vapors.
- Heater should never be covered or have any blockage to the flow of fresh air to the heater.

WARNING: Risk of electrical shock. More than one disconnect switch may be required to deenergize the equipment before servicing.

CAUTION: Operation of this heater in low-temperature systems requires special piping. Harmful internal condensation will occur if the inlet water temperature does not exceed 105°F. Warranty claims will be denied when condensation occurs.

CAUTION: If this heater is to be installed above radiation level, it must be provided with a low water cut-off device at the time of heater installation.

CAUTION: If this heater is to be installed in a negative or positive pressure equipment room, there are special installation requirements. Consult factory for details.

BEFORE INSTALLATION

Raypak strongly recommends that this manual be reviewed thoroughly before installing your Delta Limited heater. Please review the General Safety information before installing the heater. Factory warranty does not apply to heaters that have been improperly installed or operated. (Refer to the warranty at the back of this manual.) Installation and service must be performed by a qualified installer, service agency or gas supplier. If, after reviewing this manual, you still have questions which this manual does not answer, please contact the manufacturer or your local Raypak representative.

Thank you for purchasing a Raypak product. We hope you will be satisfied with the high quality and durability of our equipment.

Product Receipt

On receipt of your heater it is suggested that you visually check for external damage to the shipping crate. If the crate is damaged, make a note to that effect on the Bill of Lading when signing for the shipment. Remove the heater from the shipping packaging. Report any damage to the carrier immediately.

On occasion, items are shipped loose. Be sure that you receive the correct number of packages as indicated on the Bill of Lading.

Claims for shortages and damages must be filed with the carrier by consignee. Permission to return goods must be received from the factory prior to shipping. Goods returned to the factory without an authorized Returned Goods Receipt number will not be accepted. All returned goods are subject to a restocking charge. When ordering parts, you must specify the model and serial number of the heater.

When ordering under warranty conditions, you must also specify the date of installation.

Purchased parts are subject to replacement only under the manufacturer's warranty. Debits for defective replacement parts will not be accepted and will be replaced in kind only per Raypak's standard warranties.

Model Identification

The model identification number and heater serial number are found on the heater rating plate located on

the lower right outside jacket of the heater. The model number will have the form H8 1259B or similar depending on the heater size and configuration. The letter(s) in the first group of characters identifies the application (H = Hydronic Heating, WH = Domestic Hot Water (DHW)). The number which follows identifies the firing mode (1 or 4 = on-off, 3 = 2-stage, 8 = 3-stage and 9 = 4-stage). The second group of characters identifies the size of the heater (four numbers representing the approximate MBTUH input), and, where applicable, a letter, indicating the manufacturing series.

Ratings and Certifications

Standards:

- ANSI Z21.13 · CSA 4.9 - latest edition, Gas-Fired Hot Water Boilers
- CAN 3.1 - latest edition, Industrial and Commercial Gas-Fired Package Boilers
- ANSI Z21.10.3 · CSA 4.3 - latest edition Gas Water Heaters

All Raypak heaters are National Board Approved, and design-certified and tested by the Canadian Standards Association (CSA) for the U.S. and Canada. Each heater is constructed in accordance with Section IV of the American Society of Mechanical Engineers (ASME) Heater Pressure Vessel Code and bears the ASME stamp. The heater also complies with the latest edition of ASHRAE 90.1 Standard.

WARNING: Altering any Raypak pressure vessel by installing replacement heat exchangers, tube bundle headers, or any ASME parts not manufactured and/or approved by Raypak will instantly void the ASME and CSA ratings of the vessel and any Raypak warranty on the vessel. Altering the ASME or CSA ratings of the vessel also violates national, state, and local approval codes.

Installations at Elevation

Rated inputs are suitable for up to 5,000 ft elevation without de-rating. Consult the factory for installations at altitudes over 5,000 ft above sea level.

Component Locations

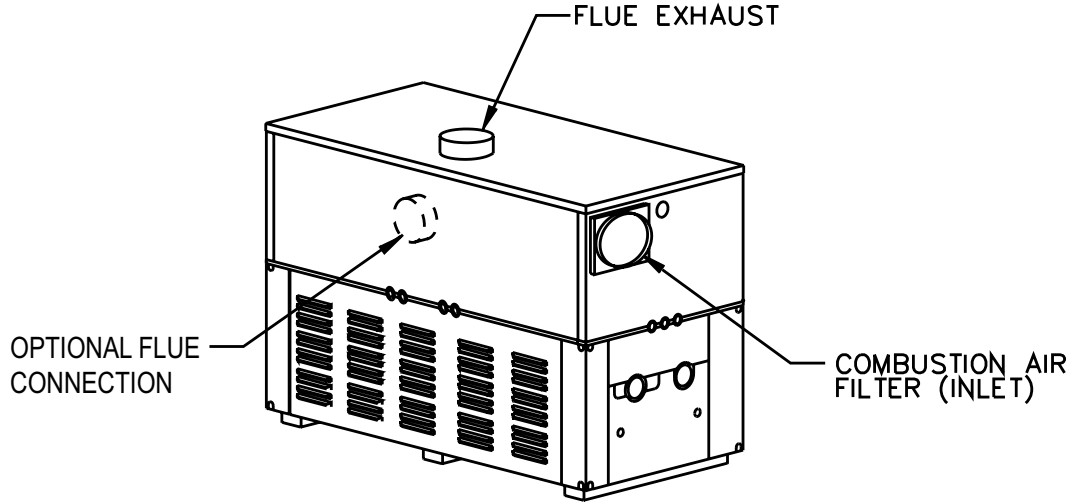

Fig. 1: Component Locations – Back

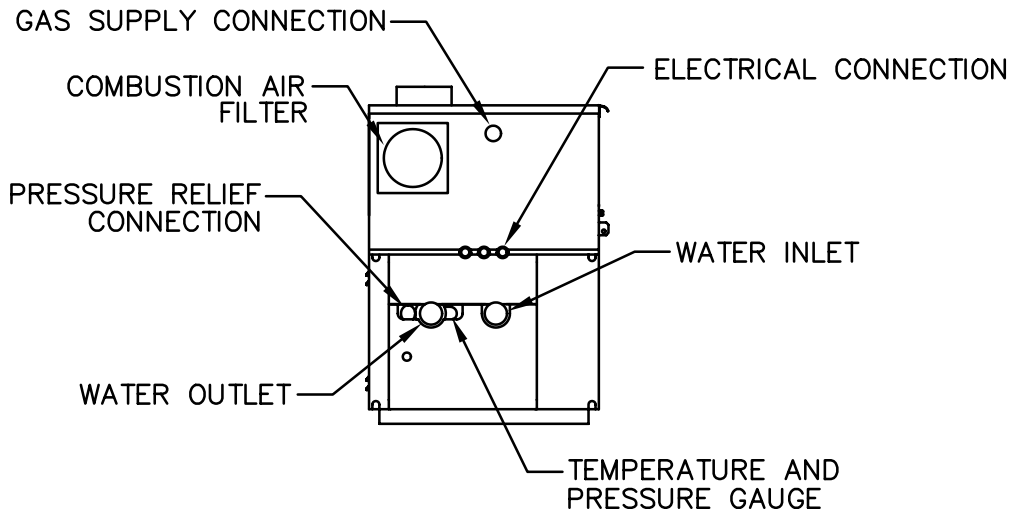
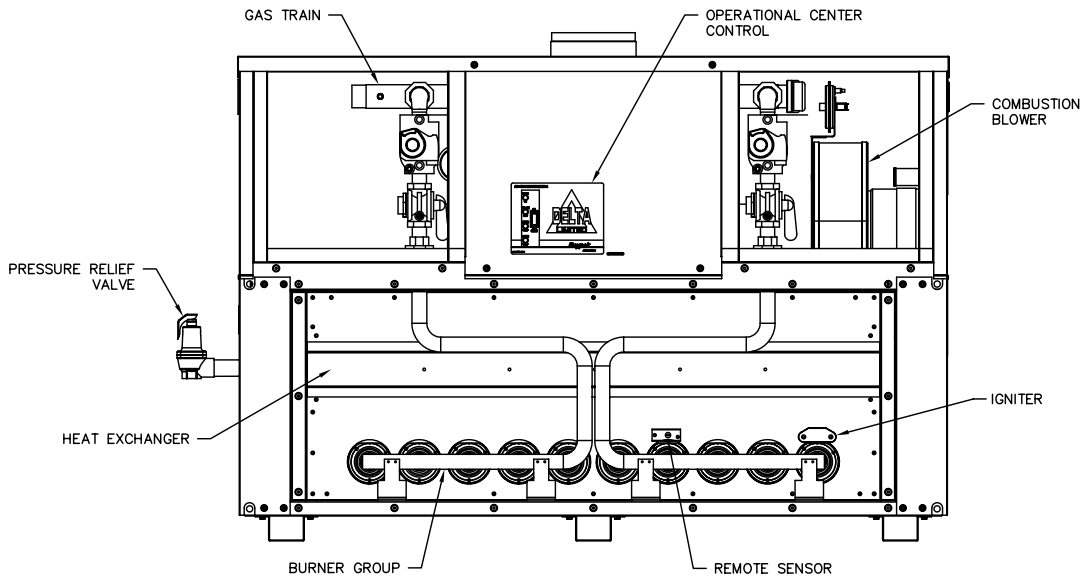

Fig. 2: Component Locations – Left Side



Panels removed for clarity

Fig. 3: Component Locations – Front

General Information

Model No.	Quantity of			Vent Size (in.)	
	Burners	Gas Valves	Blowers	Flue	Intake
399B	8	1	1	6	6
499B	10	2	1	6	6
649B	13	2	1	8	6
749B	15	2	1	8	6
899B	18	3	1	8	6
989B	11	2	2	10	10
1259B	14	3	2	12	10
1529B	17	4	2	12	10
1799B	20	4	2	14	10
1999B	23	5	3	14	10
2069B	23	5	3	14	10
2339B	26	5	3	16	10

Table A: Basic Data

Model No.	Burners per Valve					Stages				% Fire at Stage			
	1	1A	2	3	4	1	2	3	4	1	2	3	4
399B	8					1					100		
499B	5		5			1	1, 2			50	100		
649B	7		6			1	1, 2			54	100		
749B	8		7			1	1, 2			53	100		
899B	6		6	6		1, 2	1, 2, 3			66	100		
989B	6		5			1	1, 2			54	100		
1259B	5		3	6		1	1, 2	1, 2, 3		36	57	100	
1529B	6		4	4	3	1	1, 2	1, 2, 3	1, 2, 3, 4	35	59	82	100
1799B	6		4	5	5	1	1, 2	1, 2, 3	1, 2, 3, 4	30	50	75	100
1999B	4	5	5	5	4	1, 1A	1, 1A, 2	1, 1A, 2, 3	1, 1A, 2, 3, 4	39	61	83	100
2069B	4	5	5	5	4	1, 1A	1, 1A, 2	1, 1A, 2, 3	1, 1A, 2, 3, 4	39	61	83	100
2339B	5	6	5	5	5	1, 1A	1, 1A, 2	1, 1A, 2, 3	1, 1A, 2, 3, 4	42	62	81	100

Table B: Manifold Data

GENERAL SAFETY

To meet commercial hot water use needs, the high limit safety control on this water heater is adjustable up to 210°F. However, water temperatures over 125°F can cause instant severe burns or death from scalds. When supplying general purpose hot water, the recommended initial setting for the temperature control is 125°F.

Safety and energy conservation are factors to be considered when setting the water temperature on the thermostat. The most energy-efficient operation will result when the temperature setting is the lowest that satisfies the needs of the application.

Water temperature over 125°F can cause instant severe burns or death from scalds. Children, disabled and elderly are at highest risk of being scalded.

- Feel water before bathing or showering.
- Temperature limiting valves are available.

NOTE: When this water heater is supplying general purpose hot water for use by individuals, a thermostatically controlled mixing valve for reducing point of use water temperature is recommended to reduce the risk of scald injury. Contact a licensed plumber or the local plumbing authority for further information.

Maximum water temperatures occur just after the heater's burner has shut off. To determine the water temperature being delivered, turn on a hot water faucet and place a thermometer in the hot water stream and read the thermometer.

Time/Temperature Relationships in Scalds

The following chart details the relationship of water temperature and time with regard to scald injury and may be used as a guide in determining the safest water temperature for your applications.

Water Temp.	Time to Produce Serious Burn
120°F	More than 5 minutes
125°F	1-1/2 to 2 minutes
130°F	About 30 seconds
135°F	About 10 seconds
140°F	Less than 5 seconds
145°F	Less than 3 seconds
150°F	About 1-1/2 seconds
155°F	About 1 second

Table courtesy of The Shriners Burn Institute

Table C: Time to Produce Serious Burn

The temperature of the water in the heater can be regulated by using the temperature controller. To comply with safety regulations, the temperature controller is set at the lowest setting when shipped from the factory.

To adjust the water temperature, insert a small straight screwdriver into the adjustment screw on the front of temperature controller and turn the wheel to the desired setting (See Fig. 4.).

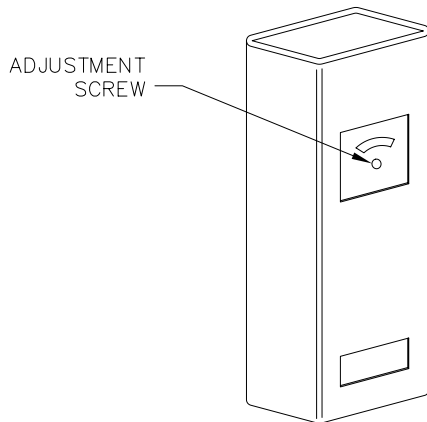

Fig. 4: Temperature Control

CAUTION: Hotter water increases the risk of scalding! There is a hot water scald potential if the thermostat is set too high.

INSTALLATION

Installation Codes

Installations must follow these codes:

- Local, state, provincial, and national codes, laws, regulations and ordinances
- National Fuel Gas Code, ANSI Z223.1/NFPA 54 – latest edition (NFGC)
- National Electrical Code, ANSI/NFPA 70 - latest edition (NEC)
- Standard for Controls and Safety Devices for Automatically Fired Boilers, ANSI/ASME CSD-1, when required (CSD-1)
- For Canada only: CAN/CGA B149 Installation Code (B149) and CSA C22.1 C.E.C. Part 1 (C22.1)

Equipment Base

The heater should be mounted on a level, structurally sound surface. The heater is approved for installation on a combustible surface but must NEVER be installed on carpeting. Gas-fueled equipment installed in enclosed parking garages must be located at least 18 in. above the floor.

Stacking

Delta Limited units can be stacked two units high with an optional stacking rack. A stacking kit is available from Raypak for this type of installation.

CAUTION: The heaters should be located in an area where water leakage will not result in damage to the area adjacent to the appliances or to the structure. When such locations cannot be avoided, it is recommended that a suitable catch pan, adequately drained, be installed under the appliance. The pan must not restrict air flow.

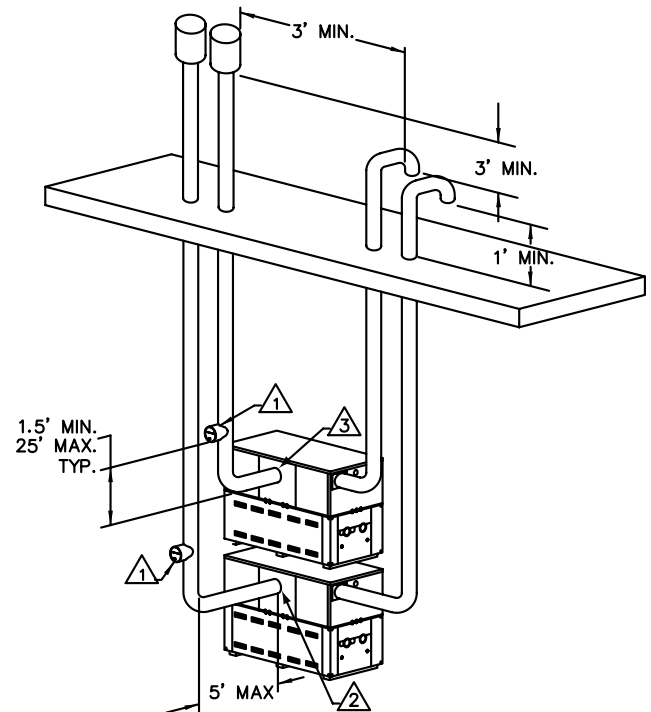

NOTE:

- ① USE A SINGLE ACTING BAROMETRIC DAMPER IN CATEGORY I, WHEN THE VERTICAL RISE EXCEEDS 25 FEET.
- ② REQUIRES OPTIONAL VENT TEE.
- ③ REQUIRES OPTIONAL VENT TEE IF VENTED OUT BACK OF HEATER.

Fig. 5: Typical Stacked Installation

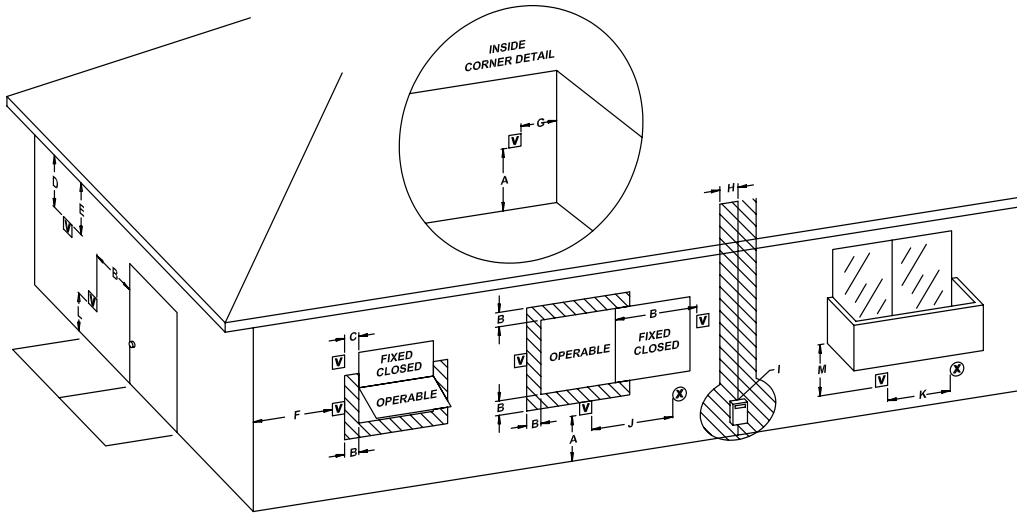

Fig. 6: Minimum Clearances from Vent/Air Inlet Terminations – Indoor and Outdoor Installations

		U.S. Installations ¹	Canadian Installations ²
A	Clearance above grade, veranda, porch, deck, or balcony	1 ft (30 cm)	1 ft (30 cm)
B	Clearance to window or door that may be opened	4 ft (1.2m) below or to side of opening; 1 foot (30 cm) above opening	3 ft (91 cm)
C	Clearance to permanently closed window	*	*
D	Vertical clearance to ventilated soffit located above the terminal within a horizontal distance of 2 ft (61cm) from the centerline of the terminal	5 ft (1.5m)	*
E	Clearance to unventilated soffit	*	*
F	Clearance to outside corner	*	*
G	Clearance to inside corner	6 ft (1.83m)	*
H	Clearance to each side of center line extended above meter/regulator assembly	*	3 ft (91 cm) within a height 15 ft above the meter/regulator assembly
I	Clearance to service regulator vent outlet	*	6 ft (1.83m)
J	Clearance to non-mechanical air supply inlet to building or the combustion air inlet to any other appliance	4 ft (1.2m) below or to side of opening; 1 ft (30 cm) above opening	3 ft (91 cm)
K	Clearance to mechanical air supply inlet	3 ft (91 cm) above if within 10 ft (3m) horizontally	6 ft (1.83m)
L	Clearance above paved sidewalk or paved driveway located on public property	7 ft (2.13m)	7 ft (2.13m) †
M	Clearance under veranda, porch, deck or balcony	*	12 in. (30 cm) TT

¹ In accordance with the current ANSI Z223.1/NFPA 54 National Fuel Gas Code

² In accordance with the current CAN/CSA-B149 Installation Codes

† Vent terminal shall not terminate directly above sidewalk or paved driveway located between 2 single family dwellings that serves both dwellings

TT Permitted only if veranda, porch, deck, or balcony is fully open on a minimum of two sides beneath the floor and top of terminal and underside of veranda, porch, deck or balcony is greater than 1 ft (30cm)

* Clearances in accordance with local installation codes and the requirements of the gas supplier

Table D: Vent/Air Inlet Termination Clearances

In addition, the heater shall be installed such that the gas ignition system components are protected from water (dripping, spraying, rain, etc.) during appliance operation or service (circulator replacement, control replacement, etc.).

Clearances

Indoor Installations

Heater Side	Minimum Clearance from Combustible Surfaces	Recommended Service Clearance
Floor*	0"	0"
Rear	1"	6"
Water Side	12"	24"
Other Side	1"	24"
Top	1"	6"
Front	Open	24"
Vent	2"	2"

* DO NOT install on carpeting.

Table E: Clearances – Indoor Installations

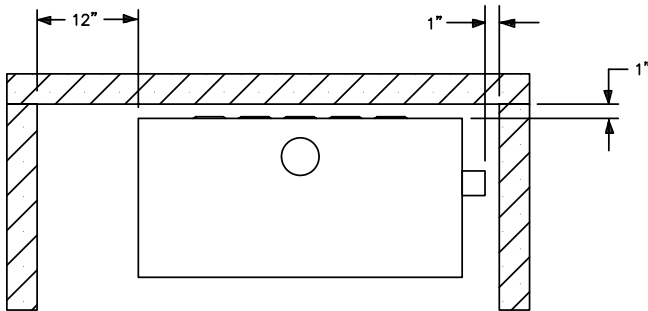

TOP VIEW

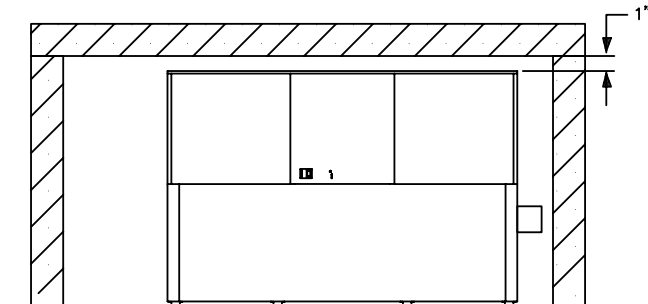

FRONT VIEW

Venting not shown for clarity. Heater must be vented per instructions in this manual

Fig. 7: Minimum Clearances from Combustible Surfaces – Indoor Installations

When installed according to the listed minimum clearances from combustible construction, these heaters can still be serviced without removing permanent structural construction around the heater. However, for ease of servicing, we recommend a clearance of at least 24 in. in front, and at least 12 in. on the water connection side. This will allow the heater to be serviced in its installed location without movement or removal of the heater.

Service clearances less than the minimums may require removal of the heater to service either the heat exchanger or the burner tray. In either case, the heater must be installed in a manner that will enable the heater to be serviced without removing any structure around the heater.

Outdoor Installations

These heaters are design-certified for outdoor installation. Heaters must not be installed under an overhang that is less than 3 ft from the top of the heater. Three sides must be open in the area under the overhang. Roof water drainage must be diverted away from heaters installed under overhangs.

Heater Side	Min. Clearance from Combustible Surfaces	Recommended Service Clearance
Front	Open	24"
Rear	12"	6"
Water Side	36"	36"
Other Side	36"	36"
Top	Unobstructed	36"
Vent	N/A	N/A

Table F: Clearances – Outdoor Installations

These clearances are required when the outdoor vent cap is used. If installing the heater outdoors with a vent stack, the indoor clearances may be utilized.

The combustion air intake hood **MUST** be used for outdoor installations. The hood is shipped loose and installed on the side of the heater over the filter box at the jobsite.

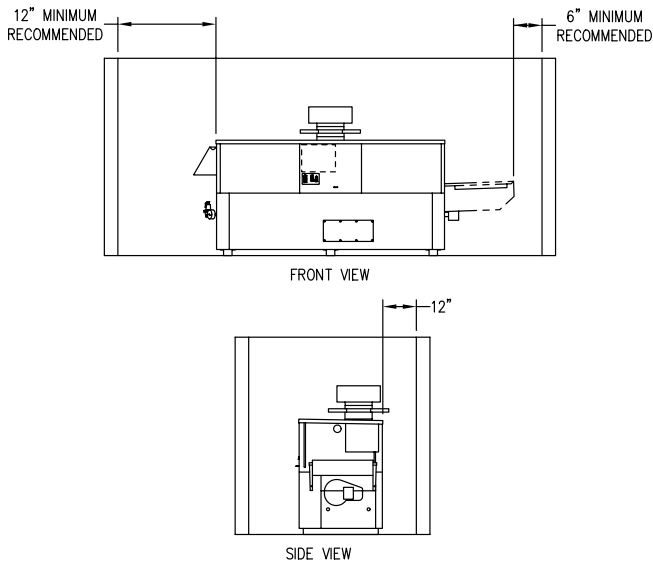

Fig. 8: Minimum Clearances from Combustible Surfaces – Outdoor Installations

Combustion and Ventilation

NOTE: Use of the heater in construction areas where fine particulate matter, such as concrete or dry-wall dust, is present may result in damage to the heater that is not covered by the warranty. If operated in a construction environment, a clean source of combustion air must be provided directly to the heater.

Air

Indoor Units

The heater must be supplied with sufficient quantities of non-contaminated air to support proper combustion and equipment ventilation. Combustion air can be supplied via conventional means where combustion air is drawn from the area immediately surrounding the heater, or via direct vent, where combustion air is drawn directly from outside. All installations must comply with the requirements of the NFGC (U.S.) and

CAUTION: Combustion air must not be contaminated by corrosive chemical fumes which can damage the heater and void the warranty. (See the Appendix.)

NOTE: It is recommended that the intake vent be insulated to minimize sweating.

B149 (Canada), and all local codes.

Reversing Air Filter

Follow these instructions to change the air duct connection from the left-hand side (standard) to the right-hand side:

1. Remove the four screws and the dust cover from the right-hand side of the heater.
2. Remove the four screws and the air filter bracket from the left-hand side of the heater.
3. Reverse the components and reattach in the new location, making sure that the air filter locking bracket is on the bottom. (The air filter locking bracket is reversible.)

Direct-Ducted Combustion Air

In certain applications it may be desirable to duct the combustion air directly to the heater. This should be done with PVC, CPVC or single-wall galvanized ducting. The duct will attach directly to the collar on the air filter housing located on the side of the heater. The ducting is attached to the air filter housing collar using three or four sheet metal screws (not supplied) equally distributed around the circumference of the duct.

Conventional Combustion Air Supply

U.S. Installations

All Air from Inside the Building

The confined space shall be provided with **TWO** permanent openings communicating directly with an additional room(s) of sufficient volume so that the combined volume of all spaces meets the criteria for a room large in comparison (NFGC). The total input of all gas utilization equipment installed in the combined

CAUTION: This type of installation is recommended if damaging airborne contaminants are or will be present in the heater area. See the Appendix regarding air contamination.

space shall be considered in making this determination. Each opening shall have a minimum free area of 1 in.² per 1,000 BTUH (2,225 mm² per kW) of the total input rating of all gas utilization equipment in the confined space, but not less than 100 in.² (645 cm²). One opening shall commence within 12 in. (305 mm) of the top, and one opening shall commence within 12 in. (305 mm) of the bottom of the enclosure. The minimum dimension of air openings shall be not less than 3 in. (76 mm) in any direction.

All Air from Outdoors

The confined space shall communicate with the outdoors in accordance with one of the methods below. The minimum dimension of air openings shall not be less than 3 in. (76 mm) in any direction. Where ducts are used, they shall be of the same cross-sectional area as the net free area of the openings to which they connect.

1. **Two permanent openings**, one commencing within 12 in. (305 mm) of the top, and one commencing within 12 in. (305 mm) of the bottom of the enclosure, shall be provided. The openings shall communicate directly, or by ducts, with the outdoors or spaces (crawl or attic) that freely communicate with the outdoors.
 - a. Where directly communicating with the outdoors or where communicating to the outdoors through vertical ducts, each opening shall have a minimum free area of 1 in.² per 4,000 BTUH (550 mm² per kW) of total input rating of all equipment in the enclosure.
 - b. Where communicating with the outdoors through horizontal ducts, each opening shall have a minimum free area of 1 in.² per 2,000 BTUH (1,100 mm² per kW) of total input rating of all equipment in the enclosure.
2. **One permanent opening**, commencing within 12 in. (305 mm) of the top of the enclosure, shall be permitted where the equipment has clearances of at least 1 in. (25 mm) from the sides and back and 6 in. (152 mm) from the front of the appliance. The opening shall directly communicate with the outdoors or shall communicate through a vertical or horizontal duct to the outdoors or spaces that freely communicate with the outdoors, and shall have a minimum free area of:
 - a. 1 in.² per 3,000 BTUH (740 mm² per kW) of the total input rating of all equipment located in the enclosure, and

- b. Not less than the sum of the areas of all vent connectors in the confined space.

WARNING: Do not use one permanent opening method if the equipment room is under negative pressure conditions or the equipment is common vented with other gas-fired appliances.

Canadian Installations

CAUTION: All combustion air must be drawn from the air outside of the building; the mechanical equipment room must communicate directly with the outdoors.

1. Ventilation of the space occupied by the heater shall be provided by an opening(s) for ventilation air at the highest practical point communicating with the outdoors. The total cross-sectional area of such an opening(s) shall be at least 10% of the area required in 2. and 3. (below), but in no case shall the cross-sectional area be less than 10 in.² (65 cm²).
2. For heaters using a barometric damper in the vent system there shall be a permanent air supply opening(s) having a cross section area of not less than 1 in.² per 7,000 BTUH (320 mm² per kW) up to and including 1 million BTUH, plus 1 in.² per 14,000 BTUH (160 mm² per kW) in excess of 1 million BTUH. This opening(s) shall be either located at or ducted to a point not more than 18 in. (450 mm) nor less than 6 in. (152 mm) above the floor level. The duct can also "goose neck" through the roof. The duct is preferred to be straight down and terminated 18 in. (450 mm) from the floor, but not near piping. This air supply opening requirement shall be in addition to the air opening for ventilation air required in 1. (above).

WARNING: Care must be taken to ensure that the equipment room is not under negative pressure conditions or that the equipment is not common-vented with other gas-fired appliances.

3. For heaters not using a barometric damper in the vent system, and when air supply is provided by natural air flow from outdoors for a power burner and there is no draft regulator, draft hood or similar flue gas dilution device installed in the same space, in addition to the opening for ventilation air required in 1., there shall be a permanent air supply opening(s) having a total cross-sectional area

of not less than 1 in.² for each 30,000 BTUH mm² per kW) of total rated input of the burner(s), and the location of the opening(s) shall not interfere with the intended purpose of the opening(s) for ventilation air referred to in (1). This opening(s) can be ducted to a point not more than 18 in. (450 mm) nor less than 6 in. (152 mm) above the floor level. The duct can also “goose neck” through the roof. The duct is preferred to be straight down 18 in. (450 mm) from the floor, but not near piping.

4. Refer to B149 Installation code for additional information.

Water Piping

General

The heater should be located so that any water leaks will not cause damage to the adjacent area or structures.

CAUTION: This heater requires forced water circulation when the burner is operating. See Table G and Table H for minimum and maximum flow rates and water pump selection. The pump must be interlocked with the heater to prevent heater operation without water circulation.

NOTE: Minimum pipe size for in/out connections is 2 ½ in (2 in. for 399B–899B). Verify proper flow rates and ΔT as instructed in this manual.

Reversing Water Connections

Follow these instructions to change the water connections from the left-hand side (standard) to the right-hand side.

1. Disconnect all electrical power from the heater (if applicable).
2. Label all electrical connections and conduit lines. This may include the flow switch, low water cut-off probe and/or pump.
3. Disconnect or isolate the main gas pipe from the heater (if applicable).
4. Remove both in/out and return header access panels by removing all sheet metal screws.

5. Remove all plumbing fittings to the header. This will include both inlet and outlet water pipe unions and the pressure relief valve and drain piping.
6. Remove limits, control bulbs and/or thermo-couples.
7. Remove the six (or 8) flange nuts and the in/out header from the left-hand side.
8. Remove the six (or 8) flange nuts and the return header from the right-hand side.
9. Remove the header stud bolts from each tube sheet.
10. Reverse the headers and stud bolts to the new location.
11. Install NEW red beveled O-rings flush against both tube sheets with the bevel facing outward.
12. Push the header firmly against the O-rings. Install and tighten the flange nuts onto the stud bolts until finger tight.
13. Slowly tighten the flange nuts, starting from the center nut (number 1) in Fig. 9 and working sequentially around the header as indicated. Torque all nuts to 25 ft/lb. **DO NOT OVER-TIGHTEN.**
14. Re-route the capillary(s), wiring etc. to the new location, adding thermal paste and shim to the capillary well.

Relief Valve Piping

WARNING: Pressure relief valve discharge piping must be piped near the floor and close to a drain to eliminate the potential of severe burns. Do not pipe to any area where freezing could occur. Refer to local codes.

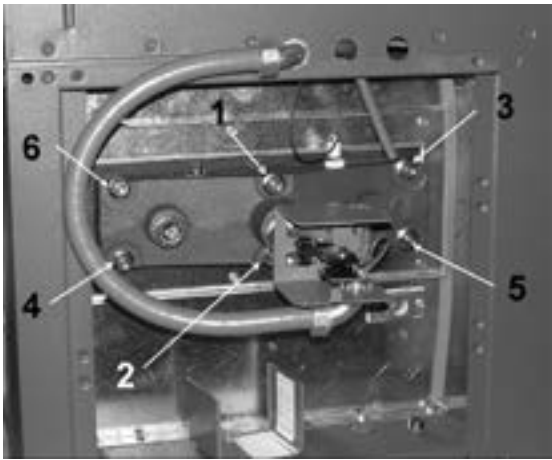

Models 399B-899B

CAUTION: Damaging internal condensation may occur if the heater inlet water temperature does not exceed 105°F (41°C) within 7 minutes of start-up.

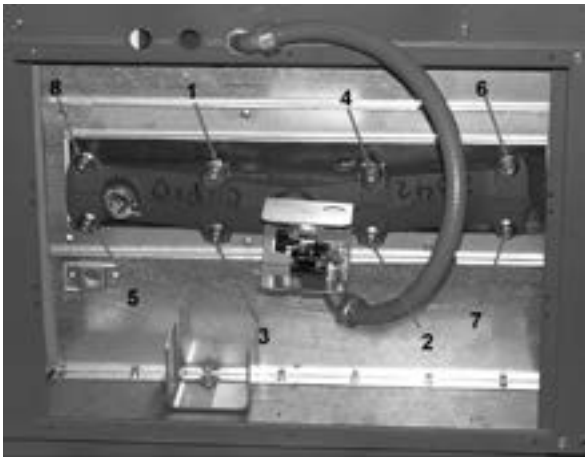

Models 989B-2339B

Fig. 9: Torque Sequence

Temperature & Pressure Gauge

The temperature and pressure gauge is factory-mounted in the in/out header.

Hydronic Heating

Cold Water Run

Cold water run differs from cold water start in that the system water entering the heater remains below 105°F (41°C) continuously. Typically, this is the case in swimming pool heating and water source heat pump applications as well as some others. If the system water is kept in a narrow temperature range, a permanent manual bypass can be employed and manually adjusted to achieve an inlet temperature of 105°F (41°C) or higher. An injector pump arrangement may also be utilized to keep the heater loop at or above 105°F (41°C). An injector pump approach has the added value of being able to adjust to changes in the system water coming back to the heater take-off.

Pump Selection

In order to ensure proper performance of your heater system, you must install a correctly sized pump. Raypak recommends using a 20°F ΔT as design ΔT. (ΔT is the temperature difference between the inlet and outlet water when the heater is firing at full rate). If a ΔT of larger than 20°F is necessary, see Table G and Table H for flow rate requirements.

Model No.	10°F ΔT		20°F ΔT		30°F ΔT		Min. Flow			Max. Flow		
	gpm	ΔP (ft)	gpm	ΔP (ft)	gpm	ΔP (ft)	gpm	ΔP (ft)	ΔT	gpm	ΔP (ft)	ΔT
399B	67	5.5	34	1.4	22	0.6	20	0.5	34	90	10.0	7
499B	84	9.1	42	2.3	28	1.1	21	0.6	40	90	10.4	9
649B			55	4.1	36	1.8	27	1.1	40	90	10.8	12
749B			63	5.7	42	2.6	32	1.5	40	90	11.3	14
899B			76	8.3	50	3.8	38	2.2	40	90	11.7	17
989B			83	5.2	55	2.3	42	1.3	40	132	13.1	13
1259B			106	9.6	71	4.3	53	2.4	40	132	14.8	16
1529B			129	15.7	86	7.1	64	4.0	40	132	16.5	19
1799B					101	10.7	76	6.0	40	132	18.3	23
1999B					112	13.8	84	7.9	40	132	19.0	25
2069B					116	14.8	87	8.5	40	132	19.0	26
2339B					132	21.4	98	12.1	40	132	21.4	30

Notes: 1. Basis for minimum flow: Models 399–899, 20 gpm or 40°F ΔT. Models 989–2339, 30 gpm or 40°F ΔT.
Basis for maximum flow: Models 399–899, 90 gpm. Models 989–2339, 132 gpm.

2. Flow switch will not operate if flow is less than 20 gpm.

Table G: Heater Rates of Flow and Pressure Drops

Pressure Drop in Feet of Head Feedwater Regulator

Raypak recommends that a feedwater regulator be in-stalled and set at 12 psi minimum pressure at the highest point of the system. Install a check valve or back flow device upstream of the regulator, with a manual shut-off valve as required by local codes.

Piping

All high points should be vented. Purge valves and a bypass valve should be installed. A heater installed above radiation level must be provided with a low wa-ter cut-off device (sales order option F-10). The heater, when used in connection with a refrigeration system, must be installed so that the chilled medium is piped in parallel with the heater with appropriate valves to pre-vent the chilled medium from entering the heater.

The piping system of a hot water heater connected to heating coils located in air handling units where they may be exposed to circulating refrigerated air, must be equipped with flow control valves or other automat-ic means to prevent gravity circulation of the heater water during the cooling cycle. It is highly recommend-ed that the piping be insulated.

Air-Separation/Expansion Tank

All heaters should be equipped with a properly sized expansion tank and air separator fitting as shown in Fig. 10.

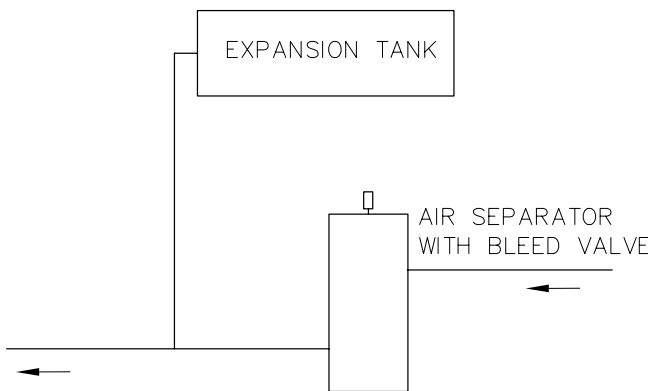

Fig. 10: Air-Separation/Expansion Tank

Three-Way Valves

Valves designed to blend water temperatures or reduce water circulation through the heater should not be used. Raypak heaters are high-recovery, low-mass

heaters which are not subject to thermal shock. Raypak offers a full line of electronic sequencers that produce direct reset of heater water temperature.

(Refer to the Controls section of the Raypak Catalog.)

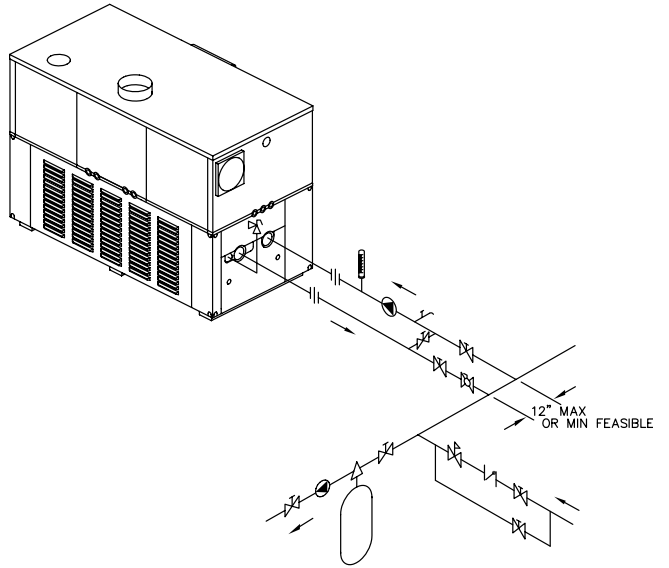

Fig. 11: Single Heater - Low-Temperature (Heat Pump) Application with Primary/Secondary Piping

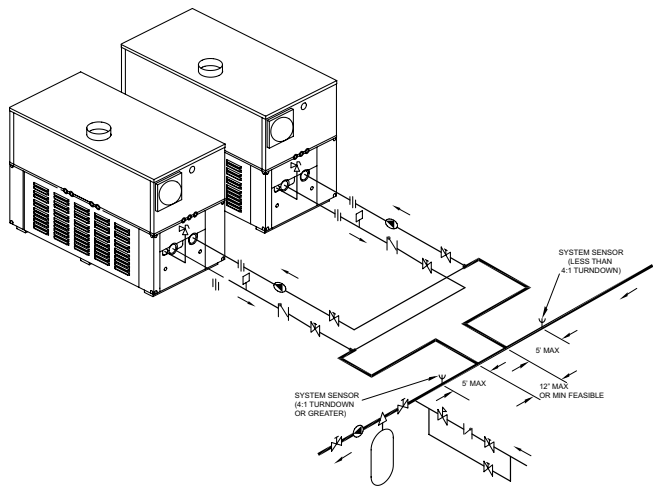

Fig. 12: Dual Heaters (Reverse/Return) with Primary/Secondary Piping

Domestic Hot Water

When designing the water piping system for domestic hot water applications, water hardness should be con-sidered. Table H indicates the suggested flow rates for soft, medium and hard water. Water hardness is expressed in grains per gallon.

Potable Water and Space Heating

CAUTION: When this heater is used for both potable water and space heating, observe the following to ensure proper operation.

1. All piping materials and components connected to the water heater for the space heating application shall be suitable for use with potable water.
2. Toxic chemicals, such as used for boiler treatment, shall not be introduced into the potable water used for space heating.
3. If the heater will be used to supply potable water, it shall not be connected to any heating system or components previously used with a non-potable water heating appliance.
4. When the system requires water for space heating at temperatures higher than 140°F, a means such as a mixing valve shall be installed to temper the water in order to reduce scald hazard potential.

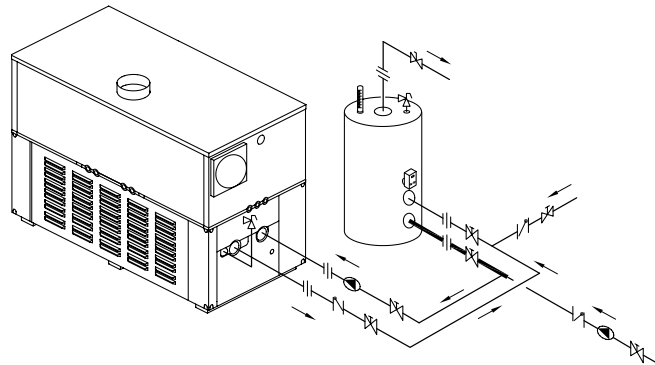

Fig. 13: Single Domestic Hot Water Heater and Storage Tank

Gas Supply

DANGER: Make sure the gas on which the heater will operate is the same type as specified on the heater's rating plate.

Gas piping must have a sediment trap ahead of the heater gas controls, and a manual shut-off valve located outside the heater jacket. It is recommended that a union be installed in the gas supply piping adjacent to the heater for servicing. A pounds-to-inches

Model No.	Soft (0–4 grains per gallon)					Medium (5–15 grains per gallon)					Hard* (16–25** grains per gallon)				
	ΔT	gpm	ΔP	MTS	SHL	ΔT	gpm	ΔP	MTS	SHL	ΔT	gpm	ΔP	MTS	SHL
399B	17	40	2.0	2	4.4	13	52	3.4	2	7.2	8	90	10.0	2	20.5
499B	21	40	2.1	2	4.5	16	52	3.5	2	7.4	9	90	10.4	2	20.9
649B	28	40	2.2	2	4.6	20	55	4.1	2	8.4	12	90	10.8	2	21.3
749B	30	42	2.6	2	5.2	20	63	5.7	2	11.1	14	90	11.3	2	21.8
899B	30	51	3.9	2	7.6	20	76	8.4	2	16.1	17	90	11.7	2	22.2
989B	28	60	2.7	2 1/2	4.6	20	83	5.2	2 1/2	8.6	13	132	13.1	2 1/2	21.0
1259B	30	72	4.4	2 1/2	7.0	20	106	9.6	2 1/2	14.8	16	132	14.8	2 1/2	22.7
1529B	30	86	7.1	2 1/2	10.7	20	132	16.5	2 1/2	24.4	20	132	16.5	2 1/2	24.4
1799B	30	101	10.7	2 1/2	15.5	23	132	18.3	2 1/2	26.1	23	132	18.3	2 1/2	26.1
1999B	30	112	13.9	2 1/2	19.7	26	132	19.0	2 1/2	26.9	26	132	19.0	2 1/2	26.9
2069B	30	116	14.8	2 1/2	21.0	27	132	19.0	2 1/2	26.9	27	132	19.0	2 1/2	26.9
2339B	30	132	21.4	2 1/2	29.3	30	132	21.4	2 1/2	29.3	30	132	21.4	2 1/2	29.3

ΔT = Temperature rise, °F.

ΔP = Pressure drop through heat exchanger, ft.

SHL = System head loss, ft. (System head loss based on heater and tank placed no more than 5 ft apart and equivalent length pipe/fittings as follows: 2 in. tube = 25 ft; 2 1/2 in. tube = 80 ft.)

gpm = Gallons per minute, flow rate.)

MTS = Minimum tubing size.

*Must utilize optional cupro-nickel tubes.

**With Hard Water (16-25 grains per gallon), the operating control must be set no higher than 130F for scale free operation. For operating temperatures above 130F, a water softener must be utilized.

Table H: Domestic Water Heater Flow Rate Requirements

regulator must be installed to reduce the gas supply pressure to a maximum of 10.5 in. WC for natural gas and 13.0 in. WC for propane gas. The regulator should be placed a minimum distance of 10 times the pipe diameter up-stream of the heater gas controls. Refer to Table I for maximum pipe lengths.

Gas Supply Connection

CAUTION: The heater must be disconnected from the gas supply during any pressure testing of the gas supply system at test pressures in excess of 1/2 psi (3.45 kPa).

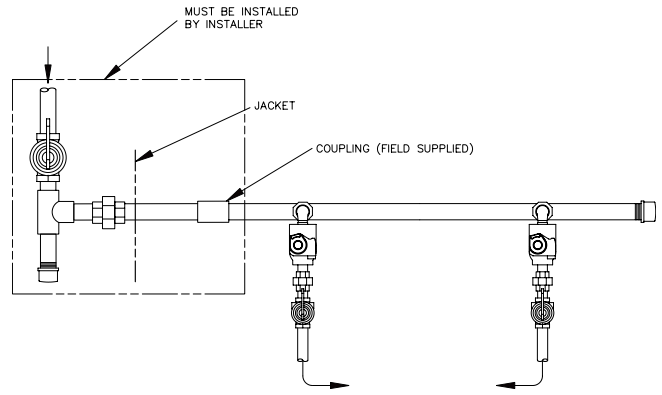

Fig. 14: Gas Supply Connection

The heater must be isolated from the gas supply piping system by closing the manual shut-off valve during any pressure testing of the gas supply piping system at test pressures equal to or less than 1/2 psi (3.45 kPa). Relieve test pressure in the gas supply line prior to reconnecting the heater and its manual shut-off valve to the gas supply line. **FAILURE TO FOLLOW THIS PROCEDURE MAY DAMAGE THE GAS VALVES.** Over pressurized gas valves are not covered by warranty. The heater and its gas connections shall be leak-tested before placing the appliance in operation. Use soapy water for leak test. **DO NOT** use an open flame.

CAUTION: Do not use Teflon tape on gas line pipe thread. A pipe compound rated for use with natural and propane gases is recommended. Apply sparingly only on male pipe ends, leaving the two end threads bare.

Model No.	3/4"		1"		1-1/4"		1-1/2"		2"		2-1/2"		3"		4"	
	N	P	N	P	N	P	N	P	N	P	N	P	N	P	N	P
399B		15	25	60	100	260	250									
499B					65	150	130	360	500							
649B					45	100	95	250	340							
749B					35	80	75	180	260	600						
899B					20	45	45	110	150	360	400					
989B									120	300	300					
1259B									75	180	170	325	560			
1529B									50	120	125	250	400			
1799B									40	100	100	225	340			
1999B									30	80	75	175	260			
2069B									30	80	75	175	260			
2339B									20	55	55	135	160	400	600	

Natural gas – 1,000 BTU per ft³, .60 specific gravity at 0.5 in. WC pressure drop
 Propane gas – 2,500 BTU per ft³, 1.53 specific gravity at 0.6 in. WC pressure drop

Table I: Maximum Equivalent Pipe Length

CAUTION: Support gas supply piping with hangers, not by the heater or its accessories. Make sure the gas piping is protected from physical damage and freezing, where required.

Reversing Gas Supply Connection

Reversing the standard fuel connection from the left-hand to the right-hand side is a simple field operation.

1. Disconnect all electrical power from the heater (if applicable).
2. Disconnect the main gas pipe from the heater (if applicable).
3. Remove the left and right front panels from the heater.
4. Locate the main gas line that traverses across the heater above the manifold risers.
5. Remove the pipe cap from the right-hand end of the main gas line.
6. Reinstall the pipe cap on the left-hand end of the main gas line.
7. Remove plastic cap from the right-hand side panel and reinstall into the standard main gas opening located on the left-hand side of the heater.
8. Remove the rubber grommet from the left-hand-side panel and reinstall into the standard main gas opening, located on the right-hand side of the heater.
9. Install a coupling, nipple, union and sediment trap onto the right-hand end of the main gas line and then install the gas line, making sure that a manual shut-off valve has been installed within 10 ft of the heater.
10. Replace the left and right front panels on the heater.

Gas Supply Pressure

A minimum of 5.0 in. WC and a maximum of 10.5 in. WC upstream gas pressure is required under load and no-load conditions for natural gas. A minimum of 11.0 in. WC and a maximum of 13.0 in. WC is required for propane gas. The gas pressure regulator(s) supplied on the heater is for low-pressure service. If upstream pressure exceeds 14.0 in. WC, an interme-

mediate gas pressure regulator, of the lockup type, must be installed.

When connecting additional gas utilization equipment to the gas piping system, the existing piping must be checked to determine if it has adequate capacity for the combined load.

The gas valve pressure regulator(s) on the heater are nominally preset at 3.5 in. WC for natural gas, and 10.5 in. WC for propane gas heater on models 302 thru 902. 9.0 in. WC for propane gas on heater models 992 thru 2342. The pressure at the gas valve outlet tap, measured with a manometer, while in operation should be 3.5 \pm 0.1 in. WC for natural gas and 10.5 in. \pm 0.1 in. WC for propane gas on heater models 302 thru 902. 9.0 to 9.5 in. WC for propane gas on heater models 992 thru 2342. If an adjustment is needed, remove the adjustment screw cover and turn the adjustment screw clockwise to increase pressure or counter-clockwise to lower pressure.

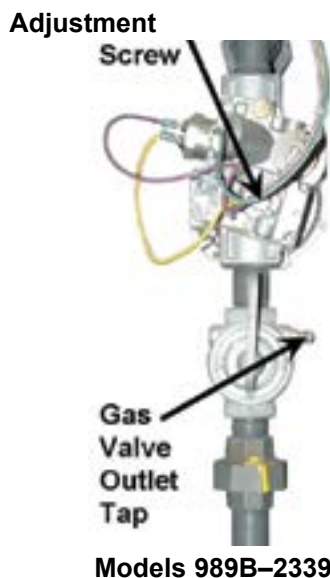
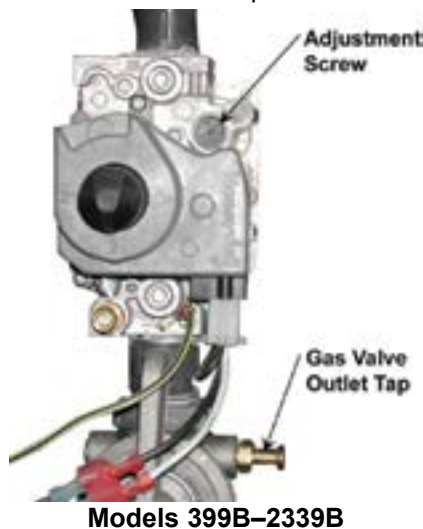

Fig. 15: Gas Valves

Electrical Power Connections

Installations must follow these codes:

- National Electrical Code and any other national, state, provincial or local codes or regulations having jurisdiction.
- Safety wiring must be NEC Class 1.
- Heater must be electrically grounded as required by the NEC.
- In Canada, CSA C22. 1 C.E.C. Part 1.

The heater is wired for 120 VAC, <12 amps. The voltage is indicated on the tie-in leads. Consult the wiring diagram shipped with the heater in the instruction packet. The remote tank control stat, thermostat, or electronic heater control (as applicable) may be connected to the stage selector terminal (See wiring diagram). 24 VAC is supplied to this connection through the heater transformer. **DO NOT attach any voltage to the stage selector terminals.** Before starting the heater check to ensure proper voltage to the heater and pump.

Install a separate disconnect means for each load. Use appropriately sized wire as defined by NEC, CSA and/or local code. All primary wiring should be 125% of minimum rating.

If any of the original wire as supplied with the heater must be replaced, it must be replaced with 105°C wire or its equivalent.

Field-Connected Controllers

It is strongly recommended that all individually-powered control modules and the heater should be supplied from the same power source.

NOTE: Field-supplied isolation relays should be installed when field-connected controllers are mounted more than 50 equivalent feet (18 Ga) from heater.

Check the Power Source

WARNING: Using a multi-meter, check the following voltages at the terminal block inside the unit. Make sure proper polarity is followed and house ground is proven. (See Fig. 18.)

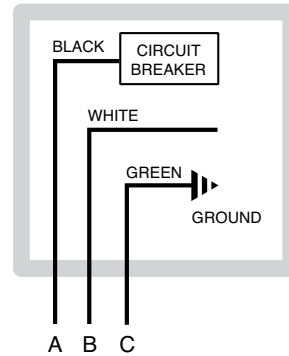

Fig. 16: Wiring Connections

Check the power source:

AC = 108 VAC Minimum, 132 VAC MAX
 AB = 108 VAC Minimum, 132 VAC MAX
 BC = <1 VAC Maximum

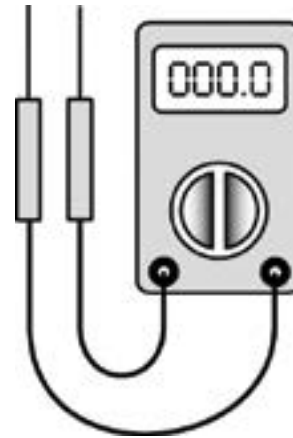

Fig. 17: Multi-meter

If the heater does not have a factory-wired stage controller, it is factory-wired in an on-off configuration with other stage terminals jumpered.

To field-connect a stage controller, remove factory-installed jumpers and wire stage controller as shown in Fig. 19–22.

Making the Electrical Connections

Refer to Fig. 16–22.

1. Verify that circuit breaker is properly sized by referring to heater rating plate. A dedicated circuit breaker should be provided.
2. Turn off all power to the heater. Verify that power has been turned off by testing with a multi-meter

prior to working with any electrical connections or components.

DANGER: SHOCK HAZARD

- 3. Observe proper wire colors while making electrical connections. Many electronic controls are polarity sensitive. Components damaged by improper electrical installation are not covered by warranty.
- 4. Provide overload protection and a disconnect means for equipment serviceability as required by local and state code.
- 5. Install heater controls, thermostats, or building management systems in accordance with the applicable manufacturers' instructions.
- 6. Conduit should not be used as the earth ground.

CAUTION: Label all wires prior to disconnection when servicing controls. Wiring errors can cause improper and dangerous operation. Verify proper operation after servicing.

Make sure electrical power to the heater is disconnected to avoid potential serious injury or damage to components.

NOTE: A grounding electrode conductor shall be used to connect the equipment grounding conductors, the equipment enclosures, and the grounded service conductor to the grounding electrode.

Field Wiring Connection

ON/OFF CONTROL 399B-2339B STAGE SELECTOR

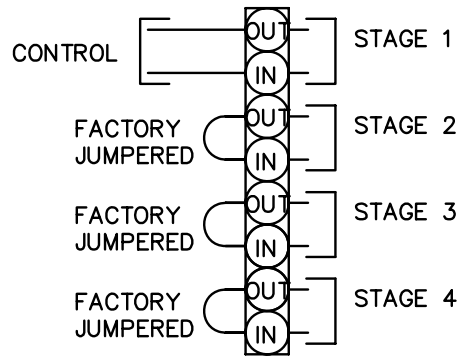

Fig. 19: On-Off Wiring Connections

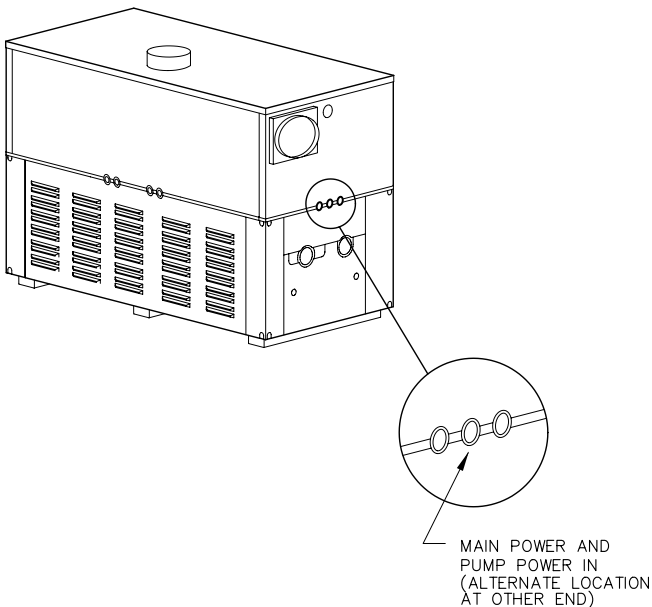
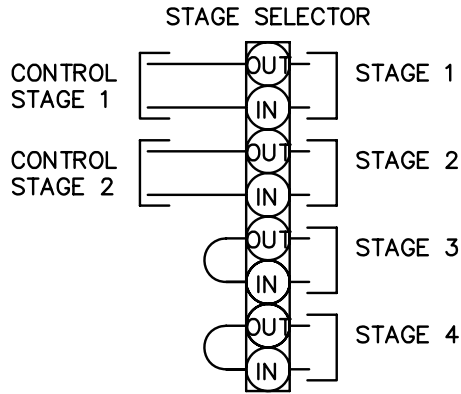

Fig. 18: Wiring Location

2-STAGE 499B-749B & 989B



3-STAGE 1259B

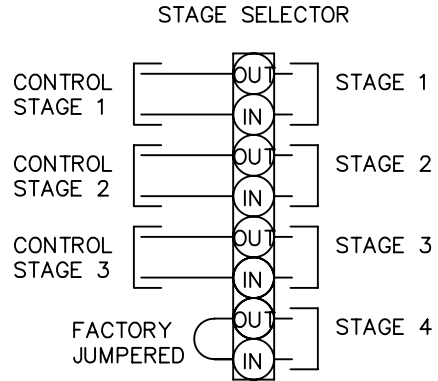
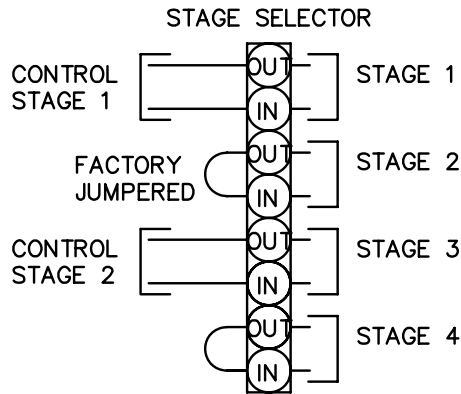

Fig. 21: 3-Stage Wiring Connections

2-STAGE 899B



4-STAGE 1529B-2339B

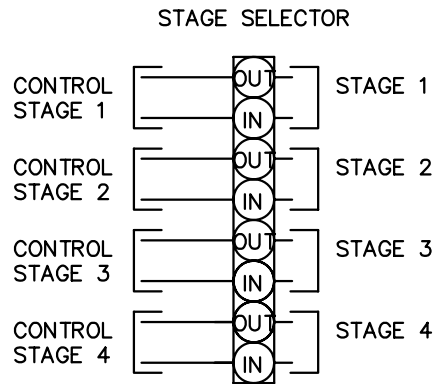

Fig. 22: 4-Stage Wiring Connection

2-STAGE 1259B-2339B

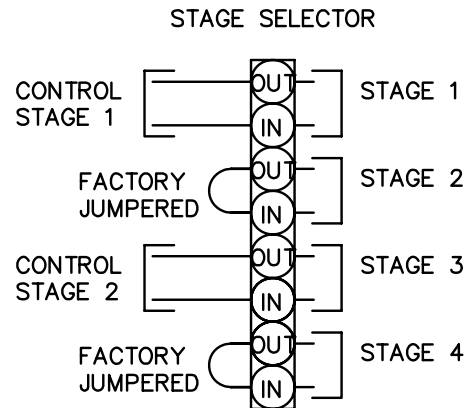
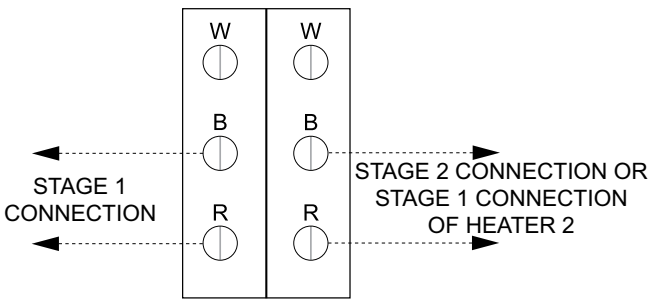

Fig. 20: 2-Stage Wiring Connections

Installer action is required to electrically enable your heater to operate after making the power connections. You must make a closed contact connection on Stage 1 connector of the Central Point Wiring (CPW) board for temperature control connections. This will be done based on the controller option selected with your heater order.

1. For Closed-Loop Water-Source Heat Pump applications with fixed bypass, your heater should be configured to operate in an on-off firing mode. This means that you will connect a single-pole control to stage one of the CPW board. Then jumper the remaining firing stages. For example, if your heater is a Model 1529B, you will jumper stages two, three and four. Then your heater will either be on at full fire, or it will be off.
2. For 2-stage controller connections, connect each stage of the control to the corresponding stage of the CPW board in the heater, i.e., stage 1 of the heater to stage 1 of the control; stage 2 of the heater to stage 2 of the control, as shown in Fig. 22 and Fig. 25. Set the operating control to the set-point at which you want the heater to maintain. Ensure that the sensing bulb of the control is at the point in the system that will best maintain the temperature you want. For example, when you are heating a tank of water, you want the operating control sensor bulb in the tank.



ATTACH STAGE 1 CONNECTIONS ON HEATER TO STAGE 1 CONNECTION ON TANKSTAT.
ATTACH STAGE 2 CONNECTIONS OR STAGE 1 CONNECTION OF HEATER 2 TO STAGE 2 CONNECTION ON TANKSTAT AS SHOWN IN THE DIAGRAM.

Fig. 23: 2-Stage Tankstat

3. For single-stage controller connections, attach the stage 1 connections on heater 1 to the tankstat per Fig. 26.

Heater must be electrically grounded in accordance with the NEC, and CSA C22.1 C.E.C. Part 1 in Canada.

Consult the wiring diagram shipped with the heater in the instruction packet or at the end of this section. The stage-selector terminals are for the remote tank control through the heater's 24 VAC transformer. **DO NOT attach any voltage to the stage-selector terminals.** Before starting the heater, check to ensure proper voltage to the heater and pump.

NOTE: If any of the original wire supplied with the heater must be replaced, it must be replaced with similar sized 105°C wire or its equivalent.

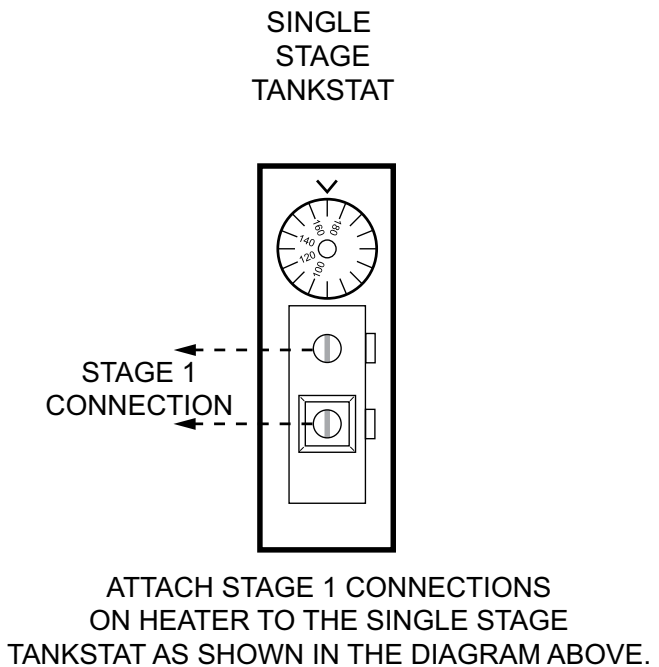

Fig. 24: Single-Stage Tankstat

Venting

CAUTION: Proper installation of flue venting is critical for the safe and efficient operation of the heater.

General

Flue Exhaust Tee

An optional Flue Exhaust Tee is available to facilitate horizontal venting. Any reference to horizontal venting that exits the back of the heater requires this tee. Refer to Table J for the appropriate kit for your model.

Model	Diameter	Order Number
399B–499B	6"	011839
649B, 749B, 899B	8"	011840
989B	10"	011841
1259B, 1529B	12"	011842
1799B, 1999B, 2069B	14"	011843
2339B	16"	011844

Table J: Flue Exhaust Tee Kits

Appliance Categories

Heaters are divided into four categories based on the pressure produced in the exhaust and the likelihood of condensate production in the vent.

Category I – A heater which operates with a non-positive vent static pressure and with a vent gas temperature that avoids excessive condensate production in the vent.

Category II – A heater which operates with a non-positive vent static pressure and with a vent gas temperature that may cause excessive condensate production in the vent.

Category III – A heater which operates with a positive vent pressure and with a vent gas temperature that avoids excessive condensate production in the vent.

Category IV – A heater which operates with a positive

vent pressure and with a vent gas temperature that may cause excessive condensate production in the vent.

See Table K for appliance category requirements.

NOTE: For additional information on appliance categorization, see appropriate ANSI Z21 Standard and the NFGC (U.S.), or B149 (Canada), or applicable provisions of local building codes.

CAUTION: When condensate traps are installed, condensate must be routed to an appropriate container for neutralization before disposal, as required by local codes.

WARNING: Contact the manufacturer of the vent material if there is any question about the appliance categorization and suitability of a vent material for application on a Category III or IV vent system. Using improper venting materials can result in personal injury, death or property damage.

Support of Vent Stack

The weight of the vent stack or chimney must not rest on the heater vent connection. Support must be provided in compliance with applicable codes. The vent should also be installed to maintain proper clearances from combustible materials.

NOTE: During winter months check the vent cap and make sure no blockage occurs from build-up of snow or ice.

Barometric Damper

A barometric damper may be required when vent heights exceed 25 feet or when the draft is greater than -0.08 in. WC. In these installations, a barometric damper (single or double acting) is recommended.

The damper should be installed NO CLOSER than 18 in. from the discharge of the unit and no closer than 18 in. from a combustible ceiling. The damper can be installed in horizontal or vertical runs of vent pipe as necessary. Installation in a bull-head tee is acceptable as shown in the NFGC.

The weights on the damper should be adjusted per the damper manufacturer's instructions for proper operation.

Use insulated vent pipe spacers where the vent passes through combustible roofs and walls.

Vent Terminal Location

1. Condensate can freeze on the vent cap. Frozen condensate on the vent cap can result in a blocked flue condition.
2. Give special attention to the location of the vent termination to avoid possibility of property damage or personal injury.
3. Gases may form a white vapor plume in winter. The plume could obstruct a window view if the termination is installed near windows.
4. Prevailing winds, in combination with below-freezing temperatures, can cause freezing of condensate and water/ice build-up on buildings, plants or roofs.
5. The bottom of the vent terminal and the air intake shall be located at least 12 in. above grade, including normal snow line.
6. Un-insulated single-wall metal vent pipe shall not be used outdoors in cold climates for venting gas-fired equipment.
7. Through-the-wall vents for Category II and IV appliances and non-categorized condensing appliances shall not terminate over public walkways or over an area where condensate or vapor could create a nuisance or hazard or could be detrimental to the operation of regulators, relief valves, or other equipment. Where local experience indicates that condensate is a problem with Category I and III appliances, this provision shall also apply.

8. Locate and guard vent termination to prevent accidental contact by people or pets.
9. DO NOT terminate vent in window well, stairwell, alcove, courtyard or other recessed area.
10. DO NOT terminate above any door, window, or gravity air intake. Condensate can freeze, causing ice formations.
11. Locate or guard vent to prevent condensate from damaging exterior finishes. Use a rust-resistant sheet metal backing plate against brick or masonry surfaces.
12. DO NOT extend exposed vent pipe outside of building. Condensate could freeze and block vent pipe.

U.S. Installations

Refer to the latest edition of the National Fuel Gas Code.

Vent termination requirements are as follows:

1. Vent must terminate at least 4 ft below, 4 ft horizontally from or 1 ft above any door, window or gravity air inlet to the building.
2. The vent must not be less than 7 ft above grade when located adjacent to public walkways.
3. Terminate vent at least 3 ft above any forced air inlet located within 10 ft.
4. Vent must terminate at least 4 ft horizontally, and in no case above or below unless 4 ft horizontal distance is maintained, from electric meters, gas meters, regulators, and relief equipment.

Combustion Air Supply	Exhaust Configuration	Heater Venting Category	Certified Materials	Combustion Air Inlet Material
From Inside Building	Vertical Natural Draft Venting	I	"B" Vent	
	Horizontal Through-the-Wall Venting	III	Stainless Steel (Gas Tight)	
From Outside Building	Vertical Natural Draft Venting	I	"B" Vent	Galvanized Steel PVC ABS CPVC
	Horizontal Through-the-Wall Venting	III	Stainless Steel (Gas Tight)	

Table K: Venting Category Requirements

5. Terminate vent at least 6 ft away from adjacent walls.
6. DO NOT terminate vent closer than 5 ft below roof overhang.
7. The vent terminal requires a 12 in. vent terminal clearance from the wall.
8. Terminate vent at least 1 ft above grade, including normal snow line.
9. Multiple sidewall vent installations require a 4 ft clearance between the ends of vent caps located on the same horizontal plane.

Canadian Installations

Refer to latest edition of B149 Installation code.

A vent shall not terminate:

1. Directly above a paved sidewalk or driveway which is located between two single-family dwellings and serves both dwellings.
2. Less than 7 ft (2.13 m) above a paved sidewalk or paved driveway located on public property.
3. Within 6 ft (1.8 m) of a mechanical air supply inlet to any building.
4. Above a meter/regulator assembly within 3 ft (915 mm) horizontally of the vertical centre-line of the regulator.
5. Within 6 ft (1.8 m) of any gas service regulator vent outlet.
6. Less than 1 ft (305 mm) above grade level.
7. Within the 3 ft (915 mm) of a window or door which can be opened in any building, any non-mechanical air supply inlet to any building or the combustion air inlet of any other appliance.
8. Underneath a verandah, porch or deck, unless the verandah, porch or deck is fully open on a minimum of two sides beneath the floor, and the distance between the top of the vent termination and the underside of the verandah, porch or deck is greater than 1 ft (305 mm).

Changing the Flue Outlet

Follow these instructions to change the flue connection from the standard top location to the rear of the heater (with optional flue exhaust tee).

1. Disconnect all electrical power from the heater (if applicable).
2. Disconnect or isolate the main gas pipe from the heater (if applicable).
3. Remove the screws, gasket and dustcover from the rear of the heater.
4. Remove the screws, stainless steel flue cover and gasket from the branch side of the tee located in the flue box at the rear of the heater.
5. Remove the screws, retaining ring and rain gasket from top of heater.
6. Remove the screws, flue collar and gasket from the run side of the tee located in the flue box on top of the heater.
7. Reverse the components and reattach in the new location.
8. Make sure that the stainless steel cover, now located on the run side of the tee, is sealed to avoid any flue gas spillage.

CAUTION: The silicone vent gaskets must be properly reinstalled to prevent flue gas leakage. Replace any torn or worn vent gaskets.

Venting Installation Tips

Support piping:

- horizontal runs - at least every 5 ft
- vertical runs - use braces
- under or near elbows

WARNING: Examine the venting system at least once a year. Check all joints and vent pipe connections for tightness, corrosion or deterioration.

Venting Configurations

For heaters connected to gas vents or chimneys, vent installations shall be in accordance with the NFGC (U.S.), or B149 (Canada), or applicable provisions of local building codes.

Natural Draft Vertical Venting (Category I)

Installation

Natural draft venting uses the natural buoyancy of the heated flue products to create a thermal driving head that expels the exhaust gases from the flue. The negative draft must be within the range of $-.01$ to $-.08$ in. WC as measured 12 in. above the appliance flue outlet to ensure proper operation. Vent material must be listed by a nationally recognized test agency.

The maximum and minimum venting length for Category I appliances shall be determined per the NFGC (U.S.) or B149 (Canada).

The diameter of vent flue pipe should be sized according to the NFGC (U.S.) and B149 (Canada). The minimum flue pipe diameter for conventional negative draft venting using double-wall Type B vent is: 6 in. for Models 399B and 499B, 8 in. for Models 649B, 749B and 899B, 10 in. for Model 989B, 12 in. for Models 1259B and 1529B, 14 in. for Models 1799B, 1999B and 2069B, and 16 in. for 2339B.

NOTE: A vent adapter (field-supplied) must be used to connect Type B vent to the unit.

The connection from the appliance vent to the stack must be as direct as possible and shall be the same diameter as, or larger than, the vent outlet. The horizontal breaching of a vent must have an upward slope of not less than $1/4$ inch per linear foot from the heater to the vent terminal. The horizontal portions of the vent shall also be supported for the design and weight of the material employed to maintain clearances and to prevent physical damage or separation of joints.

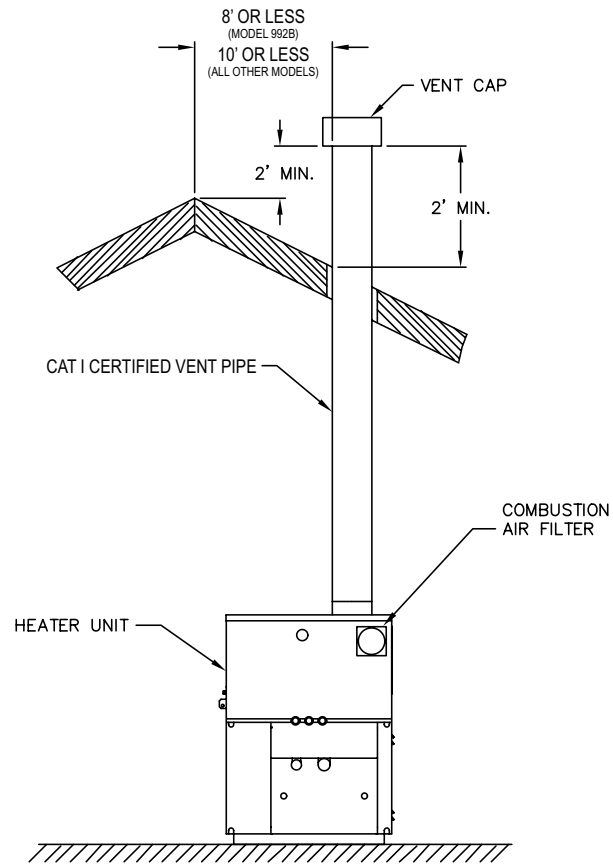

Fig. 25: Natural Draft Vertical Venting (Category I)

Termination

The vent terminal should be vertical and should terminate outside the building at least 2 ft above the highest point of the roof that is within 10 ft. The vent cap should have a minimum clearance of 4 ft horizontally from and in no case above or below (unless a 4 ft horizontal distance is maintained) electric meters, gas meters, regulators and relief equipment. The distance of the vent terminal from adjacent public walkways, adjacent buildings, open windows and building openings must be consistent with the NFGC (U.S.) or B149 (Canada). Gas vents supported only by flashing and extended above the roof more than 5 ft should be securely guyed or braced to withstand snow and wind loads.

NOTE: When an existing category I appliance is removed or replaced, the original venting system may no longer be sized to properly. Improperly sized venting system can cause formation of condensate, leakage and spillage etc.

CAUTION: A listed vent cap terminal, adequately sized, must be used to evacuate the flue products from the heaters.

Common Venting System

Manifolds that connect more than one heater to a common chimney must be sized to handle the combined load. Consult available guides for proper sizing of the manifold and the chimney. At no time should the area of the common vent be less than the area of the largest heater exhaust outlet.

WARNING: Vent connectors serving appliances vented by natural draft shall not be connected into any portion of mechanical draft systems operating under a positive pressure.

CAUTION: Vent connectors for natural draft venting systems must be Type B or better.

Common venting systems may be too large once an existing unit is removed. At the time of removal of an existing appliance, **the following steps must be fol-**

lowed with each appliance remaining connected to the common venting system placed in operation, while the other appliances remaining connected to the common venting system are not in operation.

1. Seal any unused opening in the common venting system.
2. Visually inspect the venting system for proper size and horizontal pitch and verify there is no blockage, restriction, leakage, corrosion or other unsafe condition.
3. Insofar as is practical, close all building doors and windows and all doors between the space in which the appliances remaining connected to the common venting system are located and other spaces of the building. Turn on clothes dryers and any appliance not connected to the common vent system. Turn on any exhaust fans, such as range hoods and bathroom exhausts, at maximum

Model No.	Certified Venting Material	Vent Size	Vertical Venting Height*		Combustion Air Intake Pipe Material	Air Inlet Max. Length**				
			Min.	Max.		6"	8"	10"	12"	
399B	Category I (Type B Equivalent)	6"	5'	25'	Galvanized Steel, PVC, ABS, CPVC	100'	100'			
499B						75'				
649B						8"				40'
749B		10"					75'			100'
899B										
989B										
1259B		12"				40'	75'	100'		
1529B										
1799B										
1999B		14"				40'	75'	75'		
2069B										
2339B		16"							40'	75'

* Vent lengths are based on a lateral length of 2 ft. Refer to the latest edition of the NFGC for further details. When vertical height exceeds 25 ft, consult factory prior to installation.
 ** Subtract 10 ft per elbow. Max. 3 elbows.
 Maximum combustion air duct length terminated at 100 equivalent ft.

Table L: Category I Vertical Venting

speed. Do not operate summer exhaust fan. Close fireplace dampers.

4. Place in operation the appliances being inspected. Follow the manufacturer's instructions for lighting each appliance. Adjust thermostat so appliance will operate continuously.
5. Check the pressure at a pressure tap located 12 in. above the bottom joint of the first vertical vent pipe. Pressure should be anywhere between -0.01 and -0.08 in. WC.
6. After it has been determined that each appliance remaining connected to the common venting system properly vents when tested as outlined above, return doors, windows, exhaust fans, fireplace dampers and other gas burning appliances to their previous conditions of use.
7. Any improper operation of the common venting system should be corrected so that the installation conforms with the NFGC (U.S.) or B149 (Canada). When re-sizing any portion of the common venting system, the common venting system should be re-sized to approach the minimum size as determined using the appropriate tables in the NFGC (U.S.) or B149 (Canada).

Horizontal Through-the-Wall Venting (Category III)

Installation

These installations utilize the heater-mounted blower to vent the combustion products to the outdoors. Combustion air is taken from inside the room and the vent is installed horizontally through the wall to the outdoors. Adequate combustion and ventilation air must be supplied to the equipment room in accordance with the NFGC (U.S.) or B149 (Canada).

The total length of the horizontal through-the-wall flue system should not exceed 70 equivalent ft in length. If horizontal run exceeds 70 equivalent ft, an appropriately sized extractor must be used. Each elbow used is equal to 10 ft of straight pipe. This will allow installation in one of the four following arrangements:

- 70' of straight flue pipe
- 60' of straight flue pipe and one elbow
- 50' of straight flue pipe and two elbows
- 40' of straight flue pipe and three elbows

The vent cap is not considered in the overall length of the venting system.

The vent must be installed to prevent flue gas leakage.

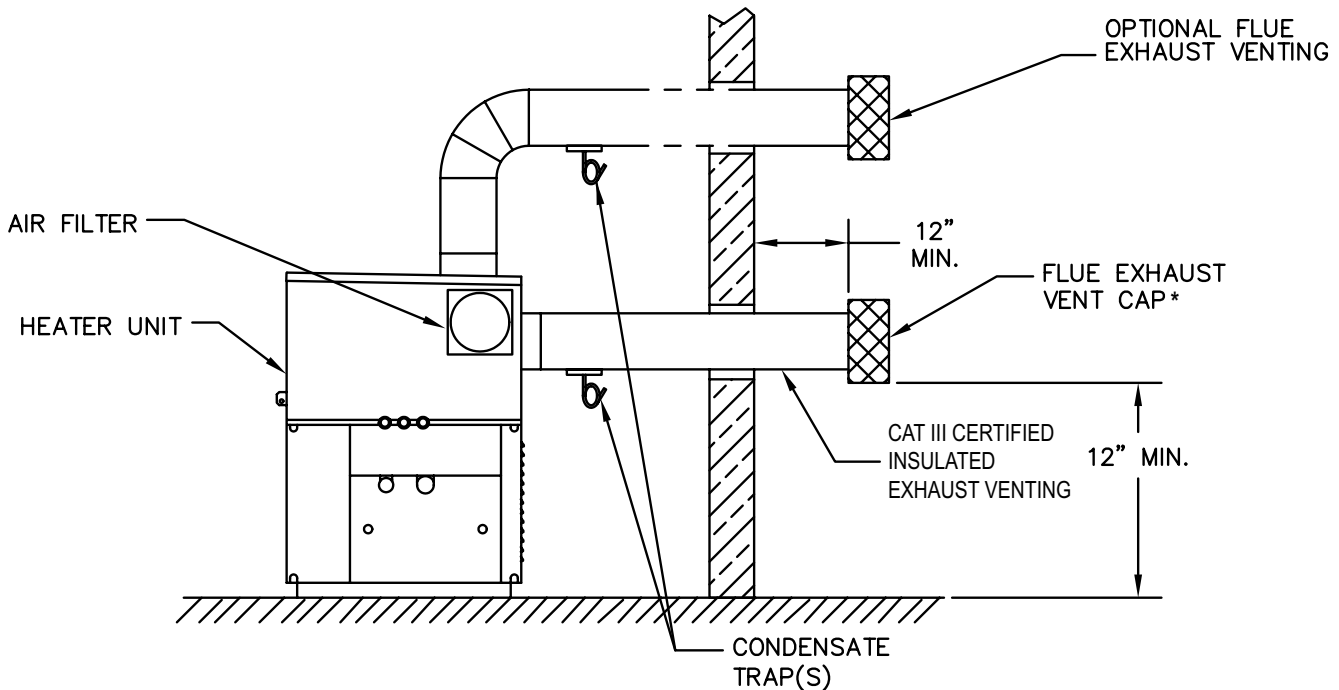

*Requires optional vent tee.

Fig. 26: Horizontal Through-the-Wall Venting (Category III)

Model No.	Certified Venting Material	Vent Size	Maximum Equivalent Vent Length*	Combustion Air Intake Pipe Material	Air Inlet Max. Length*					
					6"	8"	10"	12"		
399B	Category III	6"	70' Room Air 40' Ducted Combustion Air	Galvanized Steel, PVC, ABS, CPVC	100'					
499B					75'					
649B		8"			40'	100'				
749B					30'	80'				
899B		10"							75'	100'
989B										
1259B		12"								
1529B		14"							40'	75'
1799B										
1999B										
2069B		16"					40'	75'		
2339B										

*Subtract 10 ft per elbow. Max. 3 elbows.
Maximum combustion air duct length terminated at 100 equivalent ft.

Table M: Category III Horizontal and Direct Venting

Care must be taken during assembly to ensure that all joints are sealed properly and are airtight. The vent must be installed to prevent the potential accumulation of condensate in the vent pipes. It is required that:

1. The vent must be installed with a slight downward slope of not more than 1/4 inch per foot of horizontal run to the vent terminal.
2. The vent must be insulated through the length of the horizontal run.
3. The horizontal portions of the venting system shall be adequately supported to prevent sagging.

For installations in extremely cold climate, it is required that:

1. The vent must be installed with a slight upward slope of not more than 1/4 inch per foot of horizontal run to the vent terminal. In this case, an approved condensate trap must be installed per applicable codes.
2. The vent must be insulated through the length of the horizontal run.

Termination

The flue direct vent cap MUST be mounted on the exterior of the building. The direct vent cap cannot be installed in a well or below grade. The direct vent cap must be installed at least 1 ft above ground level and above normal snow levels. The Raypak-approved stainless steel flue direct vent cap must be used (sales order option D-15).

WARNING: No substitutions of flue pipe or vent cap material are allowed. Such substitutions would jeopardize the safety and health of inhabitants.

The vent and intake pipe material are certified to following standards:

- PVC- ANSI/ASTM D1785
- CPVC ASTM-D2846
- PPS (where applicable)- ULC-S636,
- Steel- certified for Cat IV or direct vent appliance venting.

NOTE: Please refer to table N for model specific details.

Use only the special gas vent pipes listed for use with Category III gas burning heaters, such as the AL29-4C stainless steel vents offered by Heat Fab Inc. (800-772-0739), Protech System, Inc. (800-766-3473), Z-Flex (800-654-5600) or American Metal Products (800-423-4270). Pipe joints must be positively sealed.

Follow the vent manufacturer's installation instructions carefully.

Outdoor Installation

Outdoor models are self-venting when installed with the optional factory-supplied outdoor vent kit and re-quire no additional vent piping. A special vent cap, flow switch cover and air intake hood are provided in accordance with CSA requirements, which must be installed directly on the heater. Correct clearances can

Care must be taken when locating the heater outdoors, because the flue gases discharged from the vent cap can condense as they leave the cap. Improper location can result in damage to adjacent structures or building finish. For maximum efficiency and safety, the following precautions must be observed:

1. Outdoor models must be installed outdoors and must use the outdoor vent cap, flow switch cover and air intake hood available from the manufacturer (sales order option D-11).
2. Periodically check venting system. The heater's venting areas must never be obstructed in any way and minimum clearances must be observed to prevent restriction of combustion and ventilation air. Keep area clear and free of combustible and flammable materials.
3. Do not locate adjacent to any window, door walk-way, or gravity air intake. The vent must be located a minimum of 4 ft horizontally from such areas.
4. Install above grade level and above normal snow levels.
5. Vent terminal must be at least 3 ft above any forced air inlet located within 10 ft.
6. Adjacent brick or masonry surfaces must be protected with a rust-resistant sheet metal plate.

NOTE: Condensate can freeze on the vent cap. Frozen condensate on the vent cap can result in a blocked flue condition.

NOTE: The vent cap, flow switch cover and air intake hood must be furnished by the heater manufacturer in accordance with its listing (sales order option D-11).

Freeze Protection

When installing this heater in an outdoor location that is susceptible to freezing, sales order option B-22 must be ordered. The B-22 option energizes the heater pump at a preset temperature drop to circulate water and reduces the possibility of freezing and damaging the heat exchanger or headers.

WARNING: Installation, adjustment and service of heater controls, including timing of various operating functions, must be performed by a qualified installer, service agency or the gas supplier. Failure to do so may result in control damage, heater malfunction, property damage, personal injury, or death.

WARNING: Turn off the power to the heater before installation, adjustment or service of the CPW board or any heater controls. Failure to do so may result in board damage, heater malfunction, property damage, personal injury, or death.

CAUTION: This appliance has provisions to be connected to more than one supply source. To reduce the risk of electric shock, disconnect all such connections before servicing.

CAUTION: Risk of electric shock: More than one disconnect switch may be required to de-energize the equipment before servicing.

Controls

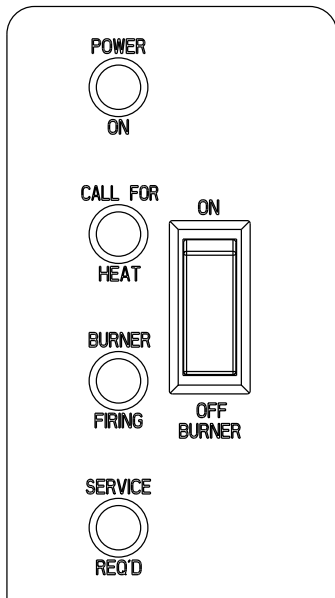

Fig. 27: Status LED Indicator Decal

External Lights		
Light	Color	Indication
Power On	Green	24 VAC switched on
Call For Heat	Amber	Thermostat is closed
Burner Firing	Blue	Burner(s) are firing
Service Req'd	Red	Service required

Table N: Status LED Indicators

Heater Sequence of Operation

Models 399B–899B

1. The black (hot) wire lead goes directly to the main power switch. This black toggle switch is located at the middle front of the control compartment.
2. When the main power switch is placed in the “ON” position, 120 VAC is applied to the 120 VAC terminal block on the circuit board and the 120/24 VAC transformer is powered.

3. 120 VAC is waiting at the N.O. contacts of the pump delay relay.
4. Terminals L1 and F1 of the ignition module are powered with 120VAC.
5. 120 VAC power is also applied to the control power connector on the circuit board.
6. 120 VAC power is waiting at relay contacts K-3 to energize the heater blower.
7. The 120/24 VAC transformer outputs 24 VAC.
8. 24 VAC is sent to power terminal L1 of the low water cut-off board (optional).
9. 24 VAC is applied to the red LED safety shutdown light on the front of the unit.
10. 24 VAC is applied to the alarm circuit (optional). If the E-5 sales option (Alarm) is included a 5 second time delay relay will not allow the alarm to sound unless the circuit stays energized for more than 5 seconds.
11. Power is output from terminal J5-24V of the CPW board to all of the safeties. All safeties are verified to ensure that it is safe to operate the heater. The safety components wired into the diagnostic board are: Manual reset high limit, low water cut-off (optional), blocked vent switch, low gas pressure switch (optional), and high gas pressure switch (optional).
12. Once all safeties have been verified to be closed a 24 VAC signal is sent to pin P3-16 of J-5 on the CPW board.
13. 24 VAC power now leaves pin P3-16 of J-5 on the CPW board and is sent to the auto-reset high limit (optional). If closed the power now goes to terminal P1-4 of J-5 on the CPW board.
14. Power is applied to terminal 24V of the pump delay relay to energize the timing circuit .
15. Relay K-1 (N.C.) will now be energized, and opens the N.C. contacts to disable the alarm (optional) and turn off the red safety shutdown light.
16. Pin P1-4 on the diagnostic board will now output a 24 VAC signal to pin 1 of the “standby switch”.

17. The “standby switch” (rocker switch) located at the lower left front of the control compartment is now powered. If the switch is “ON” and there is no call for heat (CFH), the heater is in standby mode.
18. After the standby switch is placed into the “ON” position, a 24 VAC signal is sent to the green power light on the front of the unit and the “enable/disable” connection (normally jumpered).
19. 24 VAC switched power is applied to the 24VAC terminal on the ignition module.
20. When the “enable/disable” contacts are closed, the 24 VAC signal travels to pin 1 of the stage 1 connection and waits for a CFH.
21. When a CFH occurs, a 24 VAC signal is sent from J-5 CFH on the CPW board to the amber CFH light on the front of the unit.
22. Power is now sent to terminal TRIG of the pump delay relay to energize it and close the contacts.
23. The heater pump is energized.
24. Upon sufficient flow from the heater pump, the flow switch contact will close.
25. A 24 VAC signal is then sent to the “TH” terminal located on the ignition module.
26. Once the 24 VAC “TH” signal is received, a 120 VAC signal is sent from F2 on the ignition module to the 120 VAC pilot duty terminals, located at J-14 on the circuit board.
27. The 120 VAC signal continues to the coil of relay K-3 (N.O.).
28. The 120 VAC signal continues to the 120 VAC safety terminals located at J-13 on the circuit board.
29. When the coil on relay K-3 (N.O.) is powered, the relay contacts (K-3) close and energize the blower(s) from the J-8 connections on the CPW board.
30. After proper air pressure is received in the air plenum, the air pressure switch(s) will close.
31. Power is applied to the optional equipment interlock connection (normally jumpered).
32. The 24 VAC signal is then sent to the 24 VAC safety connector.
33. 24 VAC is now sent to the pressure switch (P Switch) terminal on the ignition module.
34. Once the pressure switch signal is received at the ignition module, the hot surface igniter is energized by a 120 VAC signal from S-1 on the ignition module. (The hot surface igniter must draw greater than 3.2 amps while being energized or the ignition module red LED will flash 4 times and ignition lockout will occur after three tries).
35. Once the ignition module determines that the hot surface igniter is operating properly, a 24 VAC signal is output from terminal “valve” of the module.
36. A 24 VAC signal is sent to gas valve 1.
37. The blue LED on the front of the unit is now illuminated.
38. The coil of relay K-2 (N.O.) is now energized with the (K-2) contacts closing downstream of the stage 2 and upstream of the stage 3 connections.
39. The gas coming through the burners should ignite from the heat of the hot surface igniter and the flame should carry over from one burner to the other burners of stage 1. The remote sensor is now trying to sense the flame. If the flame is not sensed within 4 seconds, the ignition module will shut down the gas valve and retry the hot surface igniter. During ignition retry the heater must perform a 15-second pre-purge and an approximately 30-second igniter warm-up before opening gas valve 1 again. The standard ignition module will attempt ignition a maximum of three times prior to ignition lockout.
40. After gas valve 1 opens and flame rectification is received, time delay relay 1 (TD-1) is powered and starts a 5-second countdown.
41. After the 5 second countdown from TD-1, 24 VAC is waiting at pin 3 of the stage 2 connection on the CPW board.
42. After closure of the stage 2 contacts Gas valve 2 is energized.
43. After a 5 second countdown from TD-2, 24 VAC is waiting at pin 5 of the stage 3 connection on the CPW board.

44. After closure of the stage 3 contacts Gas valve 2 is energized.
45. The Heater is now operating at full fire.

Models 989B–2339B

1. The black (hot) wire lead goes directly to the main power switch. This black toggle switch is located at the middle front of the control compartment.
2. When the main power switch is placed in the “ON” position, 120 VAC is applied to the 120 VAC terminal block on the circuit board and the 120/24 VAC transformer is powered.
3. 120 VAC is waiting at the N.O. contacts of the pump delay relay.
4. Terminals L1 and F1 of the ignition module 1 are powered with 120VAC.
5. 120 VAC power is also applied to the control power connector on the circuit board.
6. Terminals L1 and F1 of the ignition module 2 are powered with 120VAC (1529B-2349B only).
7. 120 VAC power is waiting at relay contacts K-4 to energize the heater blowers.
8. The 120/24 VAC transformer outputs 24 VAC.
9. 24 VAC is sent to power terminal L1 of the low water cut-off board (optional).
10. 24 VAC is applied to the red LED safety shutdown light on the front of the unit.
11. 24 VAC is applied to the alarm circuit (optional). If the E-5 sales option (Alarm) is included a 5 second time delay relay will not allow the alarm to sound unless the circuit stays energized for more than 5 seconds.
12. Power is output from terminal J5-24V of the CPW board to all of the safeties. All safeties are verified to ensure that it is safe to operate the heater. The safety components wired into the diagnostic board are: Manual reset high limit, low water cut-off (optional), blocked vent switch, low gas pressure switch, and high gas pressure switch(s) (optional).
13. Once all safeties have been verified to be closed a 24 VAC signal is sent to pin P3-16 of J-5 on the CPW board.
14. 24 VAC power now leaves pin P3-16 of J-5 on the CPW board and is sent to the auto-reset high limit (optional). If closed the power now goes to terminal P1-4 of J-5 on the CPW board.
15. Power is applied to terminal 24V of the pump delay relay to energize the timing circuit.
16. Relay K-1 (N.C.) will now be energized, and opens the N.C. contacts to disable the alarm (optional) and turn off the red safety shutdown light.
17. Terminal J4-24 on the CPW board will now output a 24 VAC signal to pin 1 of the “standby switch”.
18. The “standby switch” (rocker switch) located at the lower left front of the control compartment is now powered. If the switch is “ON” and there is no call for heat (CFH), the heater is in standby mode.
19. The “standby switch” (rocker switch) located at the lower left front of the control compartment is now powered. If the switch is “ON” and there is no call for heat (CFH), the heater is in standby mode.
20. Power is applied to the coil of K-3. (If an ignition lockout occurs, ignition module 1 closes contacts allowing the 24VAC from K-3 to go to ground and closes the contacts to allow the unit to fire at stage 3.)
21. After the standby switch is placed into the “ON” position, a 24 VAC signal is sent to the “enable/disable” connection (normally jumpered).
22. 24 VAC switched power is applied to the 24VAC terminals on ignition modules 1 and 2.
23. When the “enable/disable” contacts are closed, the 24 VAC signal travels to pin 1 of the stage 1 connection and waits for a CFH.
24. Power is now sent to terminal TRIG of the pump delay relay to energize it.
25. The heater pump is energized.
26. Upon sufficient flow from the heater pump, the flow switch contact will close.
27. A 24 VAC signal is now sent to the “TH” terminal located on ignition module 1 and to the N.O. contacts of K-2 and K-3.

28. Once the 24 VAC "TH" signal is received, a 120 VAC signal is sent from F2 on ignition module 1 to the 120 VAC pilot duty terminals, located at J-14 on the circuit board.
29. The 120 VAC signal continues to the coil of relay K-4 (N.O.).
30. The 120 VAC signal continues to the 120 VAC safety terminals located at J-13 on the circuit board.
31. When the coil on relay K-4 (N.O.) is powered, the relay contacts (K-4) close and energize the blowers from the J-8 connections on the CPW board.
32. After proper air pressure is received in the air plenum, the air pressure switches will close.
33. Power is applied to the optional equipment interlock connection (normally jumpered).
34. The 24 VAC signal is then sent to the 24 VAC safety connector.
35. 24 VAC is now sent to the pressure switch (P Switch) terminal on the ignition modules.
36. Once the pressure switch signals are received at both ignition modules, hot surface igniter 1 is energized by a 120 VAC signal from S-1 on ignition module 1. (The hot surface igniter must draw greater than 3.2 amps while being energized or ignition lockout will occur after three tries.)
37. Once ignition module 1 determines that hot surface igniter 1 has heated up and operating properly, a 24 VAC signal is output from terminal "valve" on module 1.
38. 24 VAC signal is sent to gas valve 1.
39. The blue LED on the front of the unit is now illuminated.
40. The coil of relay K-2 (N.O.) is now energized with the (K-2) contacts closing downstream of the stage 2 connections and upstream of the stage 3 connections.
41. The gas coming through the burners should ignite from the heat of hot surface igniter 1 and the flame should carry over from one burner to the other burners of stage 1. The remote sensor is now trying to sense the flame. If the flame is not sensed within 4 seconds, the ignition module will shut down the gas valve and retry the hot surface igniter. During ignition retry the heater must perform a 15-second pre-purge and an approximately 30-second igniter warm-up before opening gas valve 1 again. The standard ignition module will attempt ignition a maximum of three times prior to ignition lockout.
42. After gas valve 1 opens and flame rectification is received, time delay relay 1 (TD-1) is powered and starts a 5-second countdown.
43. After the 5 second countdown from TD-1, the contacts close time delay relay 2 receives 24 VAC.
44. After 5 seconds gas valve 1a is now energized allowing the remainder of stage 1 to fire.
45. After the 5-second countdown from TD-2 the internal contacts close allowing 24 VAC to sit at pin 3 of the stage 2 connection on the CPW board.
46. The temperature controller closes the stage 2 contacts and gas valve 2 in energized.
47. The temperature controller closes the stage 3 contacts at J-3 on the CPW board.
48. 24 VAC signal is received at gas valve 3 (Model 1259B only).

Models 1529B–2339B Only

49. Power is applied to the "TH" terminal of ignition module 2.
50. Once the "TH" signal is received at ignition module 2, hot surface igniter 2 is energized by a 120 VAC signal from S-1 on ignition module 2. (The hot surface igniter must draw greater than 3.2 amps while being energized or ignition lockout will occur after three tries.)
51. Once the ignition module determines that the hot surface igniter has heated up and operating properly, a 24 VAC signal is output from pin "valve" on the module.
52. 24 VAC signal is received at gas valve 3.
53. The coil of relay K-5 (N.O.) is now energized with the (K-5) contacts closing downstream of the stage 4 connections.
54. Remote flame sensor 2 is trying to rectify flame.

- 55. Power is now applied to time delay relay 3 and the contacts of TD-3 located upstream of the stage 4 connection close after 5 seconds.
- 56. The stage 4 temperature controller contacts close.
- 57. Power is sent to gas valve 4.
- 58. The heater is now operating at full fire.

The standard ignition module will attempt to light three times before locking out. To reset it, turn off power to the heater, wait 30 seconds and re-apply power.

The optional single-try ignition module will lock out after failing to light one time. To reset it, press and release the small, recessed black push button located inside of the cut-out on the lower right-hand corner of the ignition module case (see Fig. 28). Turning off the power to the heater WILL NOT reset the ignition module.

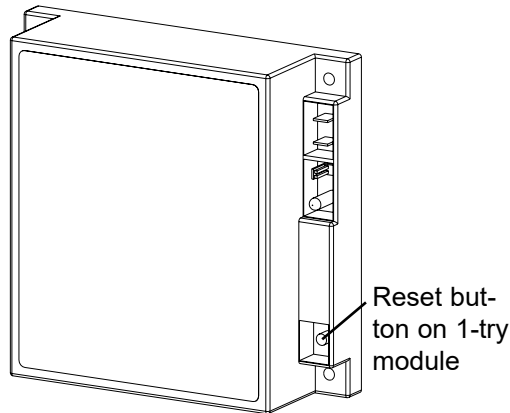

Fig. 28: Ignition Module

Ignition Module

When additional heat is needed, the combustion air blower starts to purge air from the combustion chamber for about 15 seconds. On proof-of-air flow, the air-proving switch closes and the igniter is energized. To ensure safe operation, the gas valve cannot open until the igniter is verified. The main burner is automatically lit when the device is powered and pre-purged. The heater performs its own safety check and opens the main valve only after the igniter is proven to be capable of ignition.



Fig. 29: High Limit (Manual Reset)

The heater is equipped with a manual reset high limit temperature device. Push the reset button and adjust the setting to 40 - 50°F above desired operating temperature.

Flow Switch

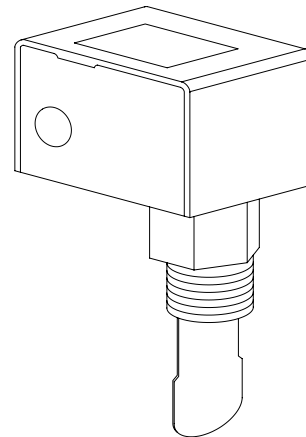

Fig. 30: Flow Switch

This dual-purpose control, mounted and wired in series with the main gas valve, shuts off heater in case of pump failure or low water flow.

Operating Control

The heater may be equipped with different types of operating controls. Consult the individual control data

Code	Condition
On	System OK; No faults present
Off	Possible control fault; Check power
1 Flash	Low air pressure, brief flashing normal on start-up
2 Flashes	Flame in combustion chamber; No call for heat
3 Flashes	Ignition lockout
4 Flashes	Low igniter current
5 Flashes	Low 24 VAC, check control supply voltage
6 Flashes	Internal fault; Replace module

Table O: Ignition Module Diagnostic LED Codes

sheets supplied with your heater paperwork. See the General Safety Section for safety precautions concerning domestic hot water applications.

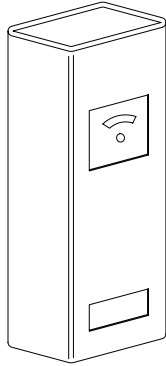

Fig. 31: Operating Control

Low Water Cut-Off (Optional)

The low water cut-off automatically shuts down the burner whenever water level drops below the level of the sensing probe. A 5-second time delay prevents premature lockout due to temporary conditions such as power fluctuations or air pockets.

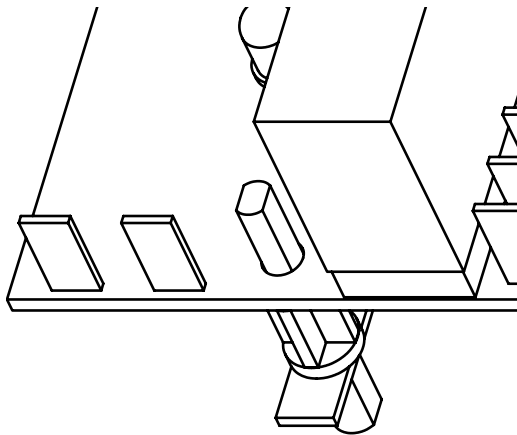

Fig. 32: Low Water Cut-Off

High and Low Gas Pressure Switches

The low gas pressure switch (standard on models 989B–2339B, optional on models 399B–899B) connection mounts upstream of the gas valve to ensure that sufficient gas pressure is present for proper regulator performance. The low gas pressure switch automatically shuts down the heater if gas supply drops below the factory setting of 5.0 in. WC for natural gas, and 10.0 in. WC for propane gas.

The high gas pressure switch (optional) connection mounts down-stream of the stage-1 gas valve. If the gas pressure regulator fails, the high gas pressure

switch automatically shuts down the burner. The high gas pressure switch automatically shuts down the heater if gas manifold pressure rises above the recommended setting of 5.0 in. WC for natural gas, and 11.5 in. WC for propane gas.

NOTE: Some jurisdictions may require two high gas pressure switches on models 1529B–2339B due to two ignition modules.

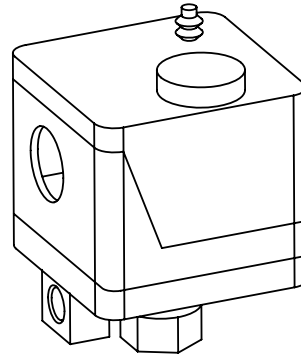

Fig. 33: High/Low Gas Pressure Switch

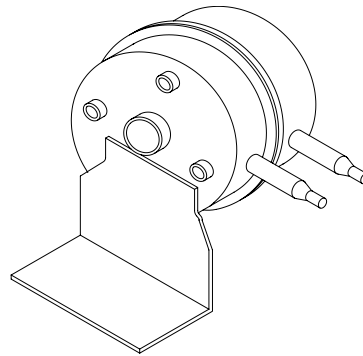

Fig. 34: Fan-Proving Switch

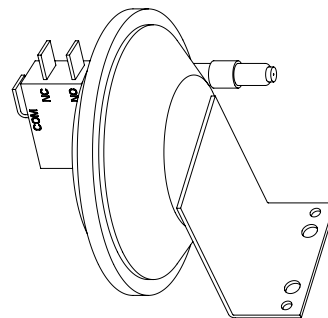
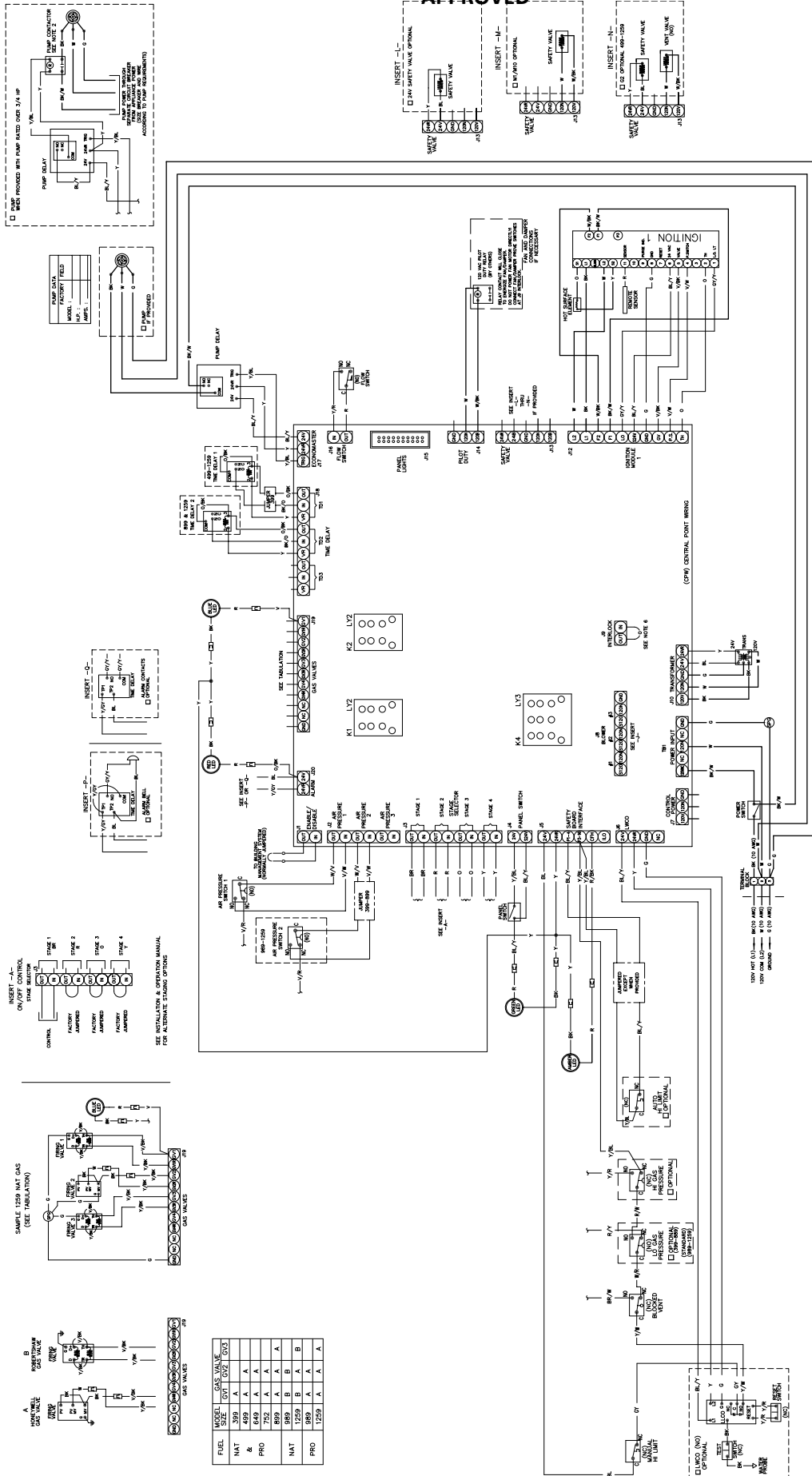

Fig. 35: Blocked Vent Switch

NOTE: The wiring diagrams in this manual show all standard options. Refer to the large wiring diagram provided with your heater for options installed on your specific unit(s).

Wiring Diagram - Models 399B-1259B

APPROVED



- NOTES:
- SOME COMPONENTS MAY INCLUDE ADDITIONAL WIRING THAT IS NOT INCLUDED IN CIRCUIT.
 - CORRECT OPERATIONAL STATUS OF SAFETIES SHOWN AS ()
 - ALL INTERLOCK SWITCHES MUST BE WIRED IN SERIES AT J9
 - IF THE HEATER IS NOT INSTALLED, THE HEATER SAFETY SWITCH MUST BE REPLACED WITH ITS EQUIVALENT 100°C.
 - IF CHECK CONTROLS PROVIDED (WIRED AS SHOWN)
 - PUMP CONTACTOR MUST BE RATED FOR APPROPRIATE PUMP SIZE.
 - IF THE PUMP CONTACTOR IS NOT RATED FOR APPROPRIATE PUMP SIZE, THE PUMP CONTACTOR MUST BE REPLACED TO PROVIDE PROPER RATING. THIS MAY RESULT IN LOCK-OUT.

KEY

○	GROUND
●	CONNECTION
—	BLACK
—	BROWN
—	GREEN
—	RED
—	WHITE
—	YELLOW

152964 3

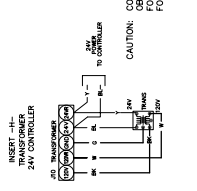
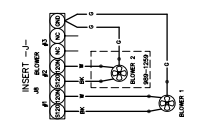

Wiring Diagram - Models 1529B-2339B

APPROVED

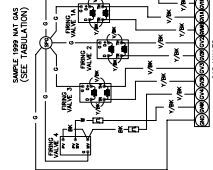
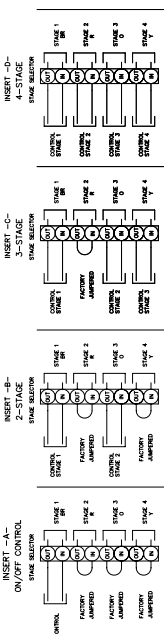
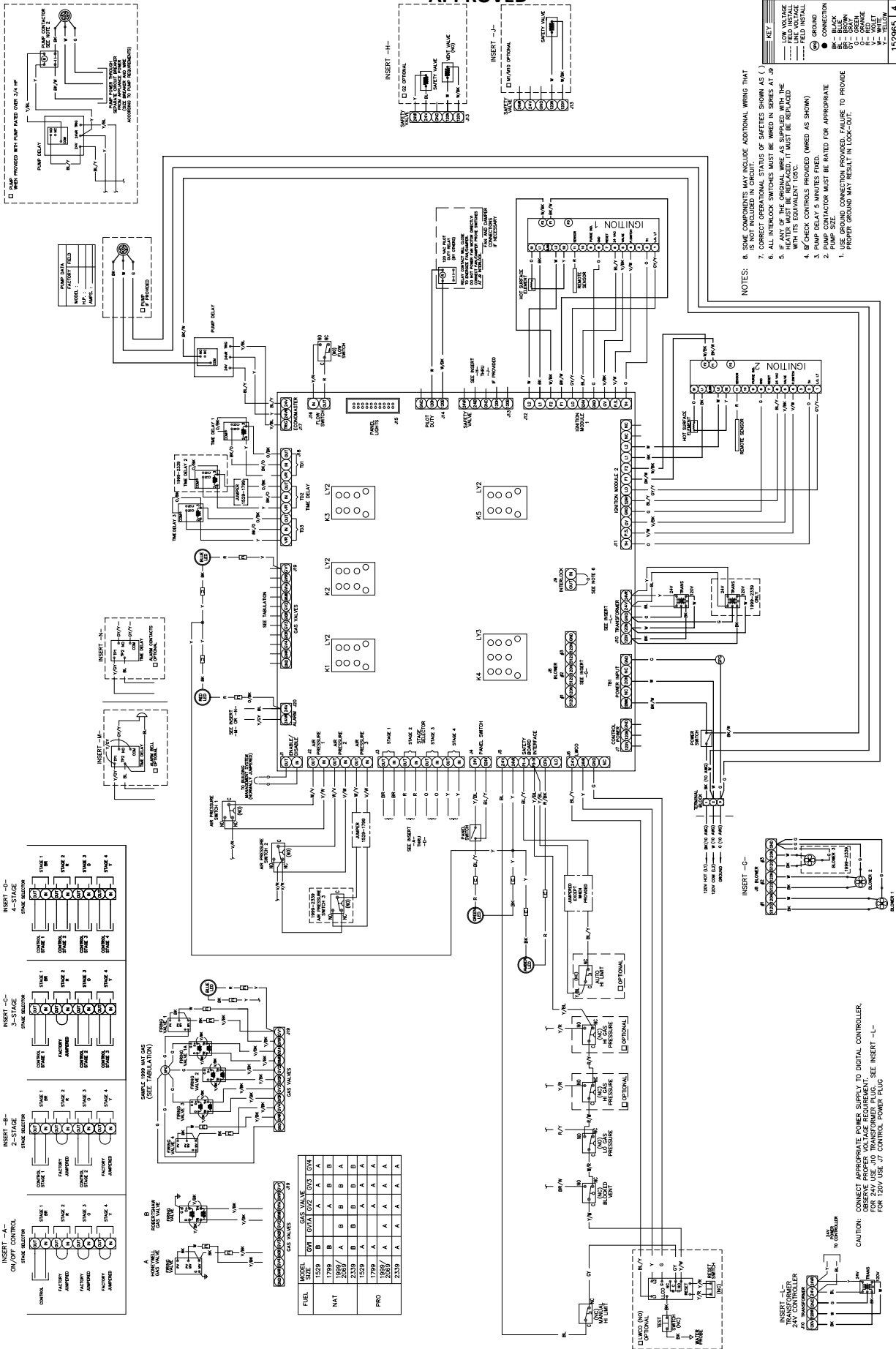

FUEL MODEL SIZE	OV1	OV2	OV3	OV4
NAT	1529 B	A	A	A
	2059 B	A	B	B
	2339 B	B	B	B
PRO	1529 A	A	A	A
	1899 A	A	A	A
	2339 A	A	A	A

- NOTES:
- SOME COMPONENTS MAY INCLUDE ADDITIONAL WIRING THAT IS NOT INCLUDED IN CIRCUIT.
 - CORRECT OPERATIONAL STATUS OF SAFETIES SHOWN AS () MUST BE MAINTAINED AT ALL TIMES.
 - IF ANY OF THE ORIGINAL WIRING IS SUPPLIED WITH THE HEATER, IT MUST BE REPLACED WITH THE EQUIVALENT LOGIC.
 - WIRING MUST BE AS SHOWN (WIRING AS SHOWN).
 - PUMP RELAY 5 MINUTES DELAY (WIRING AS SHOWN).
 - PUMP CONTACTOR MUST BE RATED FOR APPROPRIATE PUMP SIZE.
 - CONNECTIONS PROVIDED FOR SAFETY TO PROVIDE PROPER GROUND MAY RESULT IN LOCK-OUT.

KEY	1529/65	4
○	WIRING AS SHOWN	
○	FIELD INSTALL	
○	FIELD INSTALL	
○	FIELD INSTALL	
○	CONNECTION	
○	BLACK	
○	BROWN	
○	ORANGE	
○	RED	
○	WHITE	
○	YELLOW	

UNCONTROLLED DOCUMENT IF PRINTED

START-UP

Pre Start-up

Filling System (Heating Boilers)

Fill system with water. Purge all air from the system. Lower system pressure. Open valves for normal system operation, and fill system through feed pressure. Manually open air vent on the compression tank until water appears, then close vent.

Air Purge (Domestic Hot Water Heaters)

Purge all air from system before lighting heater. This can be normally accomplished by opening a downstream valve.

Venting System Inspection

1. Check all vent pipe connections and flue pipe material.
2. Make sure vent terminations are installed per code and are clear of all debris or blockage.

For Your Safety

WARNING: If you do not follow these instructions exactly, a fire or explosion may result causing property damage, personal injury or loss of life.

This appliance has a hot surface igniter. It is equipped with an ignition device which automatically lights the burners. Do not try to light the burners by hand.

BEFORE OPERATING, smell all around the appliance area for gas. Be sure to smell near the floor because some gas is heavier than air and will settle on the floor.

WHAT TO DO IF YOU SMELL GAS:

- Do not try to light any appliance.
- Do not touch any electrical switch; do not use any telephone in your building.
- Immediately call your gas supplier from a neighbor's telephone. Follow the gas supplier's instructions.

- If you cannot reach your gas supplier, call the fire department.
- Use only your hand to push in or turn the gas control knob. Never use tools. If the knob will not turn by hand, do not try to repair it, call a qualified service technician. Forced or attempted repair may result in a fire or explosion.
- Do not use this appliance if any part has been under water, immediately call a qualified service technician to inspect the appliance and to replace any part of the control system and any gas control which has been under water.
- Check around unit for debris and remove combustible products, i.e. gasoline, etc.

Pre Start-up Check

1. Verify heater is filled with water.
2. Check system piping for leaks. If found, repair immediately.
3. Vent air from system. Air in system can interfere with water circulation.
4. Purge air from gas line up to heater.

Initial Start-up

Tools Needed

- (1) 12-0-12, 24" scale U-tube manometer
- (4) 6-0-6, 12" scale U-tube manometers (minimum)
- (1) Screwdriver
- (1) Multi-meter
- (1) 3/16" Allen wrench

NOTE: Digital manometers are not recommended.

Preparation

WARNING: Do not turn on gas at this time.

Check Power Supply

With multi-meter at incoming power, check voltage between:

Hot - Common (≈ 120 VAC)

Hot - Ground (≈ 120 VAC)

Common - Ground (< 1 VAC)

WARNING: If Common - Ground is > 1 VAC, STOP: Contact electrician to correct ground failure. Failure to do this may burn out 120V-24V transformer, or may cause other safety control damage or failure.

Attach Manometers to Measure Pressures

1. Turn off main gas valve.
2. Attach 24" scale manometer to the first main gas shut-off valve pressure tapping.
3. Attach (1) 12" scale manometer to the outlet side of the second main gas shut-off valve pressure tapping.
4. Attach (1) 12" scale manometer near the fan-proving switch. Pull black cap from air pressure switch tee and connect the manometer. NOTE: Retain caps for reinstallation later.

Check Gas Supply Pressure

1. Slowly turn on main gas shut-off valve.
2. Read the gas supply pressure from the manometer; minimum supply pressure for natural gas is 5.0 in. WC, recommended supply is 7.0 in. WC, minimum supply pressure for propane gas is 11.0 in. WC (dynamic readings, all stages firing).
3. If the pressure is > 14.0 in. WC, turn off the valve.
4. Check if the service regulator is installed and/or adjust the service regulator.

Start-Up

Blower Adjustment

1. Turn off power.
2. Unplug cap at pressure switches and connect ma-nometer(s) to the tee.
3. Close all manual firing valves.
4. Turn power on.
5. Check manometers attached to fan pressure switch. The reading should be 1.4 ± 0.1 in. WC for propane gas and natural gas. If not, adjust the air shutter on the blowers to attain the correct value.
6. Turn power off.
7. Reconnect this cap.

Main Burner Adjustment

1. Turn off unit.
2. Open manual firing valves.
3. Turn on the unit, wait 15 seconds, and the igniter should glow. Look into sight glass located at each end of the heater to check igniter operation. Gas valves should open in 45-60 seconds.
4. If burner does not light on first trial. It will retry, up to three times.
5. Main burner ignition: Check manifold gas pressure at gas valve outlet pressure tap. This should read 3.5 ± 0.1 in. WC for natural gas and 10.5 ± 0.1 in. WC for propane gas on heater models 302 thru 902. 9.0 to 9.5 in. WC for Propane gas heater models 992 thru 2342.
6. If the pressure reading differs by more than ± 0.1 in. WC, remove screw cover from the gas pressure regulator and adjust main burner manifold pressure. Replace the screw cover. Repeat steps 2 to 5 on other valves as necessary.

CAUTION: Special manifold and air settings may be required. Verify rating plate and blower housing.

Safety Inspection

1. Check all thermostats and high limit settings.
2. During the following safety checks leave manometers hooked up, check and record.
3. If other gas-fired appliances in the room are on the same gas main, check all pressures on the Delta Limited with all other equipment running.
4. Check thermostats for ON-OFF operation.
5. Check high limits for ON-OFF operation.
6. While in operation, check flow switch operation.
7. Check the low gas pressure switch. (For proper adjustment, use the attached manometers, if available, to set pressure. The scales on the switch are approximate only.) Low gas pressure switch must be set at 5.0 in. WC for natural gas and 10.0 in. WC for propane gas.
8. Make sure that the high gas pressure switch (optional) is set to 1.0 in. WC above manifold pressure.

Follow-Up

Safety checks must be recorded as performed.

Turn heater on. After main burner ignition:

1. Check manometer for proper reading.
2. Cycle heater several times and re-check readings.
3. Remove all manometers and replace caps and screws.
4. Replace all gas pressure caps.
5. Check for gas leaks one more time.

Pilot Turn-Down Test

The Delta Limited heaters, depending on their size, have two to five burner sections. Each burner section is supplied gas by two gas valves incorporated into a single valve body. A maximum of three burner sections may be controlled by a single hot surface ignition system. The middle of the three burner sections is ignited directly with a hot surface ignition system.

The burner section that is ignited directly by the hot surface ignition system serves as a supervised pilot to light the burner sections on either side of it. The burner sections on either side of the supervised section (pilot) are electrically interlocked with the supervised ignition system so as they are not energized unless flame is proven on the center section which is acting as a pilot to light the right and left-hand sections.

The pilot turn-down test is conducted as follows:

1. Turn off manual valves on non-supervised burner sections.
2. Turn on electrical power and adjust thermostat to call for heat.
3. Wait for completion of ignition sequence to light burner section being utilized as a pilot for those turned off in step 1 above.
4. Gradually reduce manifold pressure (flame) on supervised burner section by slowly closing manual gas valve. Watch for shut-down due to loss of supervised flame signal as pressure is being reduced. Flame signal should be lost before manifold pressure goes below 2.0 in. WC for natural gas and 6.0 in. WC for propane gas.

Leak Test Procedure: Dual-Seat Gas Valves

Proper leak testing requires three pressure test points in the gas train.

Test point A is upstream of the automatic gas valve. On the first automatic valve, this is a bleedle valve. On the other valves, this is a plugged port. The bleedle valve on the first valve may be used for all the other valves as well.

Test point B is a bleedle valve located between the two automatic gas valve seats.

Test point C is located downstream of both automatic gas valve seats and upstream of the manual valve. On the manual valve, this is a bleedle valve. Identical readings will be found at the plugged port labeled as Alternate C.

Refer to Fig. 36. The numbers on the diagram refer to the steps below:

These tests are to be conducted with the electrical power to the heater turned off.

1. Manually close the downstream leak test valve.
2. Open test point A and connect a manometer to it. Verify that there is gas pressure and that it is within the proper range (NOTE: must not exceed 14.0 in. WC).
3. Open test point B and connect a rubber tube to it. Connect the other end of the tube to a manometer and look for a build-up of pressure. Increasing pressure indicates a leaking gas valve.
4. Next, close the upstream manual gas valve and remove the manometer from test point A and from test point B. Connect a rubber tube from test point A to test point B and open the upstream manual gas valve. Make sure that test points A & B have been opened so as to allow gas to flow. This will bring pressure to the second valve seat.
5. Open test point C and connect a second rubber tube to it. Connect the other end of the tube to a manometer and look for a build-up of pressure. In-creasing pressure indicates a leaking gas valve.
6. Remove rubber tube and manometers. Close each test point valve as the tubes are removed.
7. Connect a manometer to each test point (one at a time) and look for a build-up of pressure. If a build-up of pressure is detected, check each test point valve to see if it is tightly closed. If leak persists, replace test point valve(s).
8. After no leakage has been verified at all valve seats and test valves, open downstream leak tests valve and restore electrical power to heater.

This completes leak testing for a single Delta Limited manifold riser. Repeat steps 1-8 for each riser.

Post Start-Up Check

Check off steps as completed:

1. Verify that the heater and heat distribution units or storage tank are filled with water.
2. Confirm that the automatic air vent (if used) was opened two full turns during the venting procedure.
3. Verify that air has been purged from the system.
4. Verify that air has been purged from the gas piping, and that the piping has been checked for leaks.
5. Confirm that the proper start-up procedures were followed.
6. Inspect burner to verify flame.
7. Test safety controls: If heater is equipped with a low water cut-off or additional safety controls, test for operation as outlined by manufacturer. Burner should be operating and should go off when con-trols are tested. When safety devices are restored, burners should re-ignite after pre-purge time delay.
8. Test limit control: While burner is operating, move indicator on high limit control below actual water temperature. Burner should go off while blower and circulator continue to operate. Raise setting on limit control above water temperature and burn-er should re-ignite after pre-purge time delay.
9. Test ignition system safety device:
 - a. Turn on manual gas valve. Turn power on.
 - b. Set thermostat to call for heat.
 - c. When the heater is in operation, pull cap off of tee in air switch hose. The burner should go off immediately.
 - d. Wait 5 minutes.
 - e. Reattach cap on tee. Burner should re-ignite after pre-purge time delay.

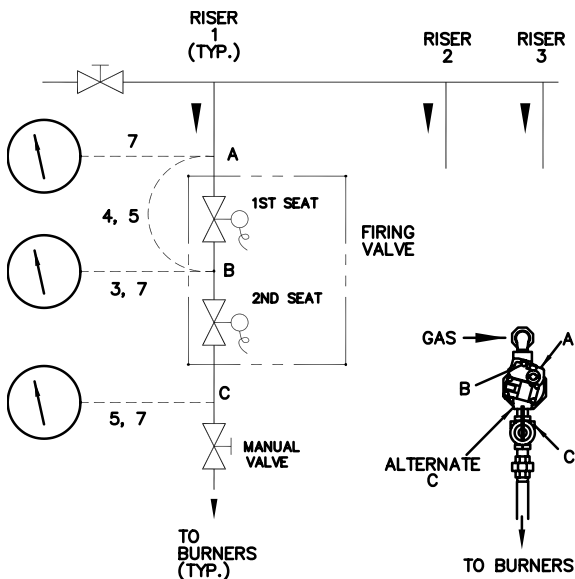

Fig. 36: Leak Test

10. To restart system, follow lighting instructions in the Operation section.
11. Check to see that the high limit control is set above the design temperature requirements of the system.

For multiple zones: Check to make sure the flow is adjusted as required in each zone.
12. Check that the heater is cycled with the thermostat. Raise to the highest setting and verify that the heater goes through the normal start-up cycle. Re-duce to the lowest setting and verify that the heater goes off.
13. Observe several operating cycles for proper operation.
14. Set the room thermostat or tankstat to desired temperature.
15. Review all instructions shipped with this heater with owner or maintenance person, return to envelope and give to owner or place the instructions inside front panel on heater.
9. Set thermostat to desired setting. The appliance will operate. The igniter will glow after the pre-purge time delay (15 seconds). After igniter reaches temperature (45 seconds) the main valve will open. System will try for ignition three times. If flame is not sensed, lockout will commence.
10. If the appliance will not operate, follow the instructions "To Turn Off Gas To Appliance," and call your service technician or gas supplier.
11. Replace access panel.
12. If heater fails to start, verify the following:
 - a. There are no loose connections or that the service switch is off.
 - b. High temperature limit switch is set above wa-ter temperature.
 - c. Thermostat is set above room temperature.
 - d. Gas is on at the meter and the heater.
 - e. Incoming gas pressure to the gas valve is NOT less than 5.0 in. WC for natural gas, 11.0 in. WC for propane gas.

OPERATION

Lighting Instructions

1. Before lighting, make sure you have read all of the safety information in this manual.
2. Set the thermostat to the lowest setting.
3. Turn off all electrical power to the appliance.
4. This appliance is equipped with an ignition device which automatically lights the burner. Do not try to light the burner by hand.
5. Remove upper front panel.
6. Turn on main manual gas valve.
7. Wait 5 minutes to clear out any gas. Then smell for gas, especially near the floor. If you then smell gas, **STOP!** Follow the steps in the safety information on the front cover of this manual. If you do not smell gas, go to next step.
8. Turn on all electrical power to the appliance.

To Turn Off Gas To Appliance

1. Set the thermostat to lowest setting.
2. Turn off all electrical power to the appliance if service is to be performed.
3. Remove upper front panels.
4. Turn off main manual gas valve.
5. Replace access panel.

TROUBLESHOOTING

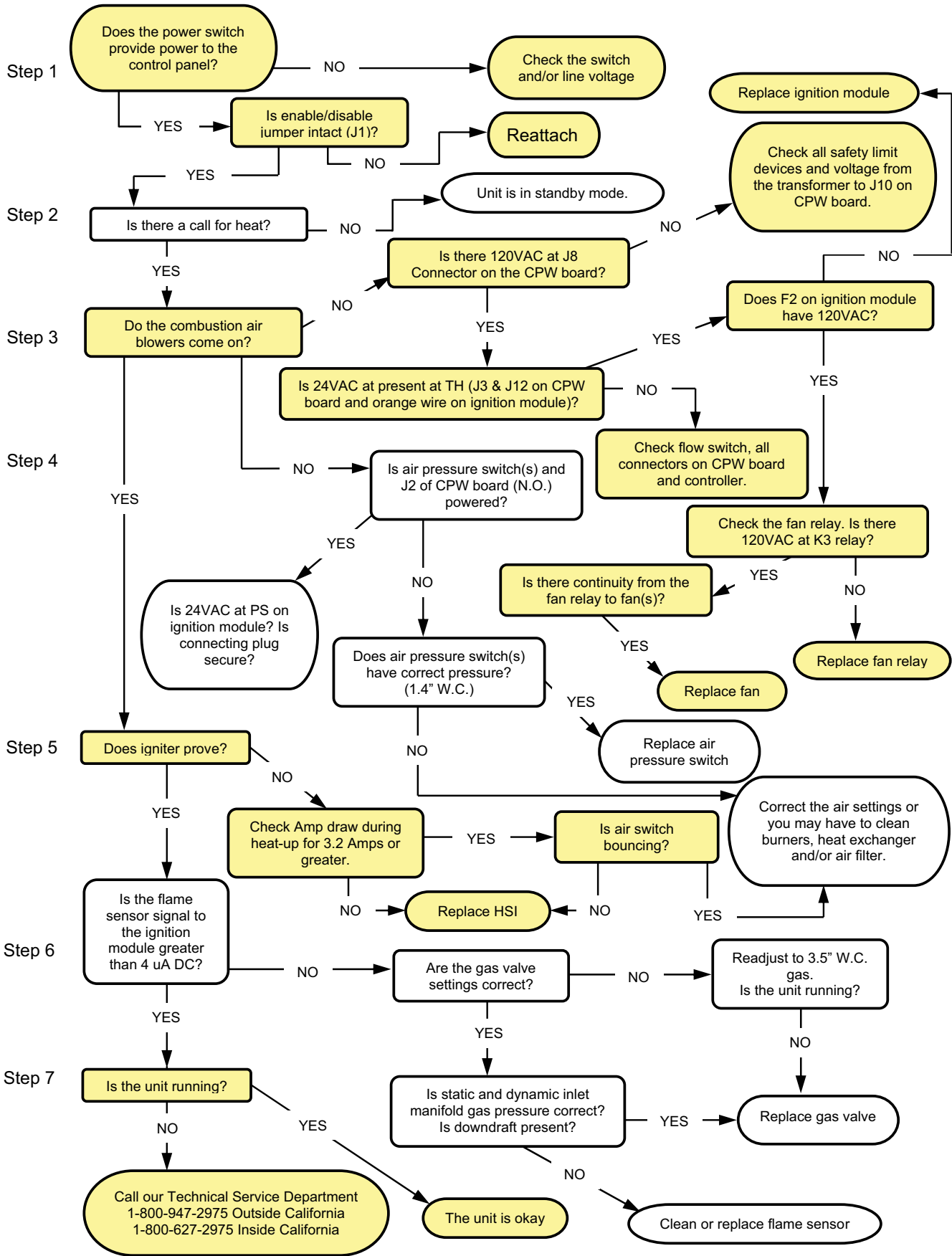

MAINTENANCE

Suggested Minimum Maintenance Schedule

Regular service by a qualified service agency and maintenance must be performed to ensure maximum operating efficiency.

Maintenance as outlined below may be performed by the owner.

Daily

1. Check that the area where the heater is installed is free from combustible materials, gasoline, and other flammable vapors and liquids.
2. Check for and remove any obstruction to the flow of combustion or ventilation air to heater.

Monthly

1. Check for piping leaks around circulators, mixing valves, relief valves, and other fittings. If found, repair at once. DO NOT use petroleum-based stop-leak compounds.
2. Visually inspect burner flame.
3. Visually inspect venting system for proper function, deterioration or leakage.
4. Check air vents for leakage.

Yearly (Beginning Of Each Heating Season)

Schedule annual service call by qualified service agency.

1. Visually check top of vent for soot. Call service person to clean. Some sediment at bottom of vent is normal.
2. Visually inspect venting system for proper function, deterioration or leakage.
3. Check that area is free from combustible materials, gasoline, and other flammable vapors and liquids.

4. Check for and remove any obstruction to the flow of combustion or ventilation air to heater.
5. Follow pre-start-up check in the Start-up section.
6. Visually inspect burner flame. It should be light blue. Remove and visually inspect hot surface igniter and sensor for damage, cracking or debris build-up.
7. Check operation of safety devices. Refer to manufacturers' instructions.
8. Follow oil-lubricating instructions on circulator if required. Over-oiling will damage circulator. Water-lubricated circulators do not need oiling.
9. To avoid potential of severe burn, DO NOT REST HANDS ON OR GRASP PIPES. Use a light touch; return piping will heat up quickly.
10. Check blower and blower motor.
11. Check for piping leaks around circulators, relief valves and other fittings. Repair, if found. DO NOT use petroleum-based stop-leak.

Periodically

1. Check relief valve. Refer to manufacturer's instructions on valve.
2. Test low water cut-off, if used. Refer to manufacturer's instructions.
3. Clean intake screen, vent terminal screen and air filter.

Preventive Maintenance Schedule

The following is required procedure in CSD-1 states and good practice for all Delta Limited installations.

Daily

1. Check gauges, monitors and indicators.
2. Check instrument and equipment settings. (See "Post Start-Up Check" on page 44.)
3. Check burner flame. (Should see light blue flame).

Weekly

For low-pressure heaters, test low-water cut-off device. (With at least one stage of the appliance on, depress the low water cut-off test button, appliance should shut-off and ignition fault light should come on. Depress reset button to reset).

Monthly

1. Check flue, vent, stack, or outlet dampers.
2. Test fan air pressure. (See "Blower Adjustment" on page 42.)
3. Test high and low gas pressure interlocks (if equipped). (See "Safety Inspection" on page 43.)

Semi-Annually

1. Recalibrate all indicating and recording gauges.
2. Check flame failure detection system components. (See "Pilot Turn-Down Test Procedure," page 43.)
3. Check firing rate control by checking the manifold pressure. (See "Main Burner Adjustment" on page 42.)
4. Check piping and wiring of all interlocks and shut-off valves.

Annually

1. Test flame failure detection system and pilot turn-down. (See "Pilot Turn-Down Test Procedure," page 43.)
2. Test high limit and operating temperature. (See "Post Start-Up Check," page 44.)
3. Check flame sensors.
4. Conduct a combustion test at full fire. Carbon di-oxide should be 7.5 to 8.5% at full fire for natural gas, and between 9.2 to 9.8% for propane gas (Carbon monoxide should be < 150 ppm).
5. Check coils for 60 cycle hum or buzz. Check for leaks at all valve fittings using a soapy water solution. Test other operating parts of all safety shut-off and control valves and increase or decrease settings (depending on the type of control) until the safety circuit opens. Reset to original setting after each device is tested.

6. Perform leakage test on gas valves. (See Fig. 36.)
7. Test air switch in accordance with manufacturer's instructions. (Turn panel switch to the "On" position until blower is proven, then turn the switch to "Off".
8. Inspect and clean burners as necessary.

As Required

1. Recondition or replace low water cut-off device (if equipped).
2. Check drip leg and gas strainers.
3. Perform flame failure detection and pilot turn-down tests.
4. Check igniter. (Resistance reading should be 42-70 ohms at ambient temperature.)
5. Check flame signal strength. (Flame signal should be greater than 1 microamp).
6. Test safety/safety relief valves in accordance with ASME Heater and Pressure Vessel Code Sections VI and VII.

APPENDIX

Inside Air Contamination

All heaters experience some condensation during start-up. The condensate from flue gas is acidic. Combustion air can be contaminated by certain vapors in the air which raise the acidity of the condensate. Higher acidity levels attack many materials including stainless steel, which is commonly used in high efficiency systems. The heater can be supplied with corrosion-resistant, non-metallic intake air vent material. You may, however, choose to use outside combustion air for one or more of these reasons:

1. Installation is in an area containing contaminants listed below which will induce acidic condensation.
2. You want to reduce infiltration into your building through openings around windows and doors.
3. You are using AL29-4C stainless steel vent pipe, which is more corrosion-resistant than standard metallic vent pipe. In extremely contaminated areas, this may also experience deterioration.

Products causing contaminated combustion air:

- spray cans containing chloro/fluorocarbons
- permanent wave solutions
- chlorinated waxes/cleaners
- chlorine-based swimming pool chemicals
- calcium chloride used for thawing
- sodium chloride used for water softening
- refrigerant leaks
- paint or varnish removers
- hydrochloric acid/muriatic acid
- cements and glues
- antistatic fabric softeners used in clothes dryers
- chloride-type bleaches, detergents, and cleaning solvents found in household laundry rooms
- adhesives used to fasten building products
- similar products

Areas where contaminated combustion air commonly exists:

- dry cleaning/laundry areas
- metal fabrication plants
- beauty shops
- refrigeration repair shops
- photo processing plants
- auto body shops
- plastic manufacturing plants

- furniture refinishing areas and establishments
- new building construction
- remodeling areas
- open pit skimmers

Check for areas and products listed above before in-stalling heater. If found, remove products permanently.



**APPROVED
LIMITED PARTS WARRANTY
DELTA LIMITED – TYPES H AND WH
MODELS 399B–2339B**

SCOPE

Raypak, Inc. ("Raypak") warrants to the original owner that all parts of this heater which are actually manufactured by Raypak will be free from failure under normal use and service for the specified warranty periods and subject to the conditions set forth in this Warranty. Labor charges and other costs for parts removal or reinstallation, shipping and transportation are not covered by this Warranty but are the owner's responsibility.

HEAT EXCHANGER WARRANTY

Domestic Hot Water

Five (5) years from date of heater installation. Includes copper heat exchanger with bronze and cast iron waterways.

Ten (10) years from date of heater installation. Includes only cupro-nickel heat exchanger with bronze or cast iron waterways.

Space Heating (Closed Loop System)

Ten (10) years from date of heater installation. Includes both cupro-nickel and copper heat exchanger with bronze or cast iron waterways.

Thermal Shock Warranty

Twenty (20) years from date of heater installation against "Thermal Shock" (excluded, however, if caused by heater operation at large changes exceeding 150°F between the water temperature at intake and heater temperature, or operating at heater temperatures exceeding 230°F).

ANY OTHER PART MANUFACTURED BY RAYPAK

One (1) year warranty from date of heater installation, or eighteen (18) months from date of factory shipment based on Raypak's records, whichever comes first.

SATISFACTORY PROOF OF INSTALLATION DATE, SUCH AS INSTALLER INVOICE, IS REQUIRED. THIS WARRANTY WILL BE VOID IF THE HEATER RATING PLATE IS ALTERED OR REMOVED.

ADDITIONAL WARRANTY EXCLUSIONS

This warranty does not cover failures or malfunctions resulting from:

1. Failure to properly install, operate or maintain the heater in accordance with our printed instructions provided;
2. Abuse, alteration, accident, fire, flood and the like;
3. Sediment or lime build-up, freezing, or other conditions causing inadequate water circulation;
4. High velocity flow exceeding heater design rates;
5. Failure of connected systems devices, such as pump or controller;
6. Use of non-factory authorized accessories or other components in conjunction with the heater system;
7. Failing to eliminate air from, or replenish water in, the connected water system;
8. Chemical contamination of combustion air or use of chemical additives to water.

PARTS REPLACEMENT

Under this Warranty, Raypak will furnish a replacement for any failed part. The failed part must first be returned to Raypak if requested, with transportation charges prepaid, and all applicable warranty conditions found satisfied. The replacement part will be warranted for only the unexpired portion of the original warranty. Raypak makes no warranty whatsoever on parts not manufactured by it, but Raypak will apply any such warranty as may be provided to it by the parts manufacturer.

TO MAKE WARRANTY CLAIM

Promptly notify the original installer, supplying the model and serial numbers of the unit, date of installation and description of the problem. The installer must then notify his Raypak distributor for instructions regarding the claim. If either is not available, contact Service Manager, Raypak, Inc., 2151 Eastman Avenue, Oxnard, CA 93030 or call (805) 278-5300. In all cases proper authorization must first be received from Raypak before replacement of any part.

EXCLUSIVE WARRANTY - LIMITATION OF LIABILITY

This is the only warranty given by Raypak. No one is authorized to make any other warranties on Raypak's behalf. THIS WARRANTY IN LIEU OF ALL OTHER WARRANTIES, EXPRESS OR IMPLIED, INCLUDING BUT NOT LIMITED TO IMPLIED WARRANTIES OF MERCHANTABILITY AND FITNESS FOR A PARTICULAR PURPOSE. RAYPAK'S SOLE LIABILITY AND THE SOLE REMEDY AGAINST RAYPAK WITH RESPECT TO DEFECTIVE PARTS SHALL BE AS PROVIDED IN THIS WARRANTY. IT IS AGREED THAT RAYPAK SHALL HAVE NO LIABILITY, WHETHER UNDER THIS WARRANTY, OR IN CONTRACT, TORT, NEGLIGENCE OR OTHERWISE, FOR ANY SPECIAL, CONSEQUENTIAL, OR INCIDENTAL DAMAGE, INCLUDING DAMAGE FROM WATER LEAKAGE. Some states do not allow limitations on how long an implied warranty lasts, or for the exclusion of incidental or consequential damages. So the above limitation or exclusion may not apply to you.

This Limited Warranty gives you specific legal rights. You may also have other rights which may vary from state to state. We suggest that you complete the information below and retain this certificate in the event warranty service is needed. Reasonable proof of the effective date of the warranty (date of installation) must be presented, otherwise, the effective date will be based on the rate of manufacture plus thirty (30) days.

Original Owner _____

Model Number _____

Mailing Address _____

Serial Number _____

Date of Installation _____

City _____ State _____ Zip Code _____

Installation Site _____

Daytime Telephone Number _____

Contractor/Installer _____

RAYPAK, INC • 2151 Eastman Avenue • Oxnard, CA 93030-9786 • (805) 278-5300 • Fax (800) 872-9725 • www.raypak.com

APPROVED

START-UP CHECKLIST FOR FAN-ASSISTED RAYPAK PRODUCTS

This start-up checklist is to be completely filled out by the service technician starting up the Raypak Boiler or Heater for the first time. All information may be used for warranty purposes and to ensure that the installation is correct. Additionally this form will be used to record all equipment operation functions and required settings.

GAS SUPPLY DATA

Regulator Model & Size _____ / _____ CFH
 Gas Line Size (in room) _____ In. NPT
 Length of Gas Line _____ Eq Ft
 Low Gas Pressure Setting _____ In. WC
 High Gas Pressure Setting _____ In. WC
 Gas Shut-Off Valve Type _____
 (Ball, Lube cock)
 Sediment Trap _____ Y/N
 Port _____ Std _____ Full

CLEARANCES

Front Clearance _____ In.
 Right Side Clearance _____ In.
 Left Side Clearance _____ In.
 Rear Clearance _____ In.
 Overhead Clearance _____ In.

ELECTRICAL

Voltage Supply (VAC) No Load _____ Load _____
 Voltage -24 VAC _____ VAC
 Voltage Com to Ground _____ VAC
 Hot Surface Igniter _____ Ohms
 Auto High Limit Setting _____ deg F
 Manual Reset High Limit Setting _____ deg F
 Operating Control Setting _____ deg F

VISUAL INSPECTION OF COMPONENTS

Verify inspection was done and condition of components are in good working order with a "yes"

Wiring Harness _____ Y/N
 Burner/s (flame) _____ Y/N
 Refractory (visual) _____ Y/N
 Remote flame sense _____ Y/N
 Covers in place for outdoor _____ Y/N

Sketch plumbing on reverse side

WATER SUPPLY

Flow Rate in GPM or Delta T _____ If Avail
Measure flow rate at full fire
 Pump Economaster setting _____ Minutes
 Low Water Cutoff _____ Test
 Number of Tanks and Size Qty _____ Gallons
 Plumbing Size _____
 Pump Size: _____ (boiler) Pump HP: _____
 Impeller trim _____ Pump Model _____
 Louvers _____ Screens _____

VENTING

Vent Size: _____ Stack Height: _____
 Category: _____ sketch vent on reverse side ***
 Vent Material: _____
 Vent Termination Type: _____
 Combustion Air Openings: Low _____ in2
 Ventilation air High _____ in2

Nominal Factory Recommended Settings

EMISSIONS SETTINGS AND TEST INFORMATION

(AT FULL FIRE)

Blower Pressure Setting _____ In. WC
 Supply Gas Pressure _____ In. WC
 Verify stable pressure static & dynamic condition
 Pilot Gas Pressure _____ In. WC
 Manifold Gas Pressure _____ In. WC

See manual or card tag
 See manual or card tag
 See manual or card tag
 See manual or card tag

The following measurements must be obtained with a Combustion Analyzer.

NOX _____ PPM Less than 20 PPM (If required by Certifying Agency)
 Free Oxygen _____ % See manual
 CO _____ PPM Less than 150 PPM
 CO2 _____ % See manual

Model Number: _____

Serial Number: _____

*** Note: draw venting with details, such as extractors, barometric dampers, blast dampers or draft inducers

Site Altitude Above Sea Level _____ Ft.

Job Name _____

Address _____

Physical Location of Boiler: Indoors _____; Outdoors _____; Ground Level _____; Roof _____; Below Grade _____

Mechanical Contractor / Installer _____

Date and Time of Start-up _____ Print Name and Signature of Start-up Technician _____

Information must be faxed to: (805) 278-5496 in order to ensure warranty consideration Attn: Service Manager

APPROVED



www.raypak.com

Raypak, Inc., 2151 Eastman Avenue, Oxnard, CA 93030 (805) 278-5300 Fax (805) 278-5468
Litho in U.S.A.

UNCONTROLLED DOCUMENT IF PRINTED