

# Advanced Design Boiler™ Vent Termination Cap

ADB MODEL NO.	OUTDOOR STACK		SIDEWALL VENT TERMINATION CAP					FLUE SUPPORT BRACKETS PART NO.
	DIA	PART NO.	A LENGTH	B HEIGHT	C WIDTH	D VENT Ø	PART NO.	
500	6"	011894	20"	8"	8"	6"	006644	012185
751	8"	011895	21-3/8"	10"	8"	8"	006646	
1001	10"	010796	23-1/2"	12"	8"	10"	006650	
1501	12"	010797	29"	14"	9-3/16"	12"	007989	012186

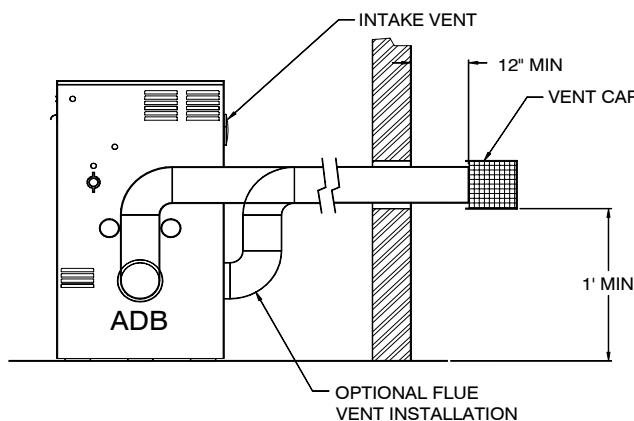

SIDEWALL TERMINATION

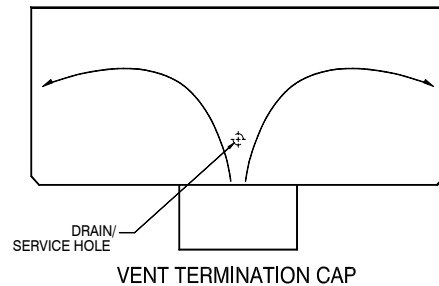
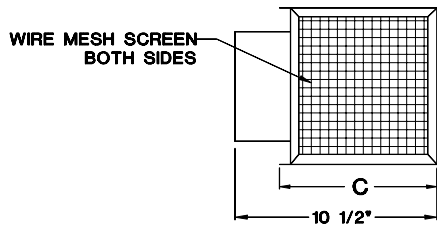
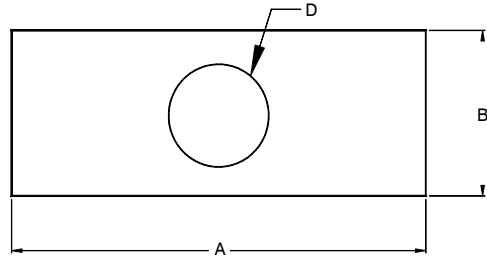
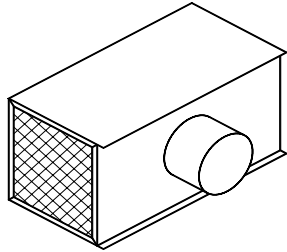
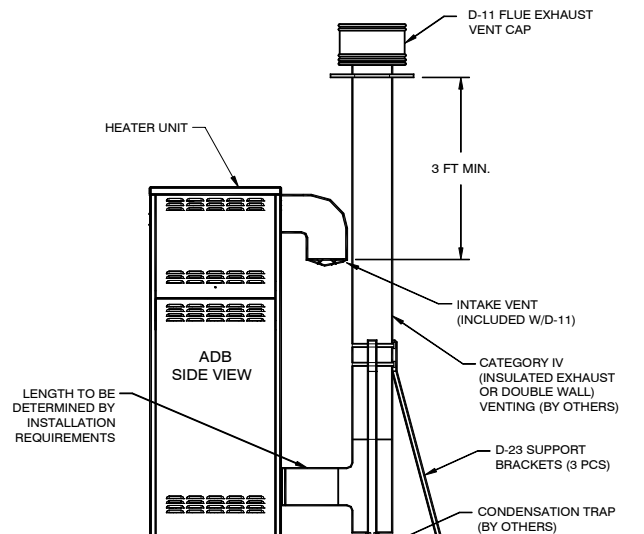

OUTDOOR TERMINATION STACK

Raypak, Inc. ▪ 2151 Eastman Avenue, Oxnard, CA 93030 ▪ (805) 278-5300 ▪ Fax (800) 872-9725 ▪ www.raypak.com

