

INSTALLATION & OPERATING INSTRUCTIONS

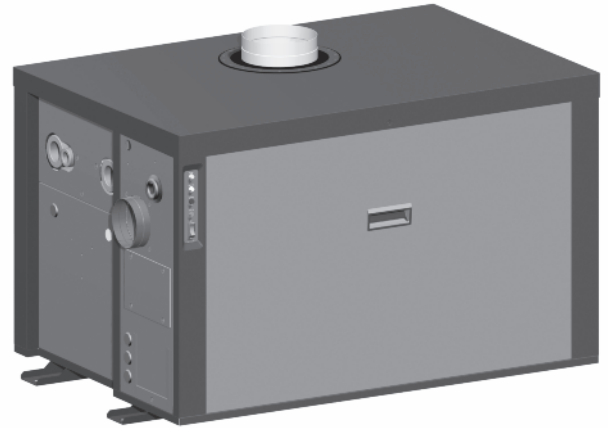

**Models HD101–HD401
Type WH1**



WARNING: If these instructions are not followed exactly, a fire or explosion may result causing property damage, personal injury or death.

FOR YOUR SAFETY: Do not store or use gasoline or other flammable vapors and liquids or other combustible materials in the vicinity of this or any other appliance. To do so may result in an explosion or fire.

WHAT TO DO IF YOU SMELL GAS:

- Do not try to light any appliance.
- Do not touch any electrical switch; do not use any phone in your building.
- Immediately call your gas supplier from a neighbor's phone. Follow the gas supplier's instructions.
- If you cannot reach your gas supplier, call the fire department.

Installation and service must be performed by a qualified installer, service agency or the gas supplier.

This manual should be maintained in legible condition and kept adjacent to the heater or in another safe place for future reference.

Raypak®
A Rheem® Company

Revision 3 reflects the following changes:
Removed California Proposition 65 warning on page 4.

CONTENTS

WARNINGS	4	WIRING DIAGRAM—MODELS	
BEFORE INSTALLATION	5	HD101-HD151	32
Product Receipt	5	WIRING DIAGRAM—MODELS	
Model Identification	5	HD201-HD401	33
Ratings and Certifications	5	HD TROUBLESHOOTING	34
Installations at Elevation	5	PRE-START-UP	35
Component Locations	6	Domestic Hot Water Heaters	35
General Information	7	Inspect Venting System	35
GENERAL SAFETY	8	Pre-Start-Up Check	35
Time/Temperature Relationships in Scalds	8	INITIAL START-UP	35
INSTALLATION	9	Tools Needed	35
Installation Codes	9	Preparation for Start-Up	35
Equipment Base	9	Check Power Supply	35
Clearances	9	Attach Manometers to	
Combustion and Ventilation Air	11	Measure Pressures	35
Conventional Combustion		Check the Gas Supply Pressure	36
Air Supply	11	Start-Up	36
Water Piping	12	Main Burner Adjustment	37
Domestic Hot Water Piping	14	Gas Valve Adjustment	37
Gas Supply	15	Safety Inspection	38
Electrical Power Connections	16	Follow-Up	38
Venting	19	POST START-UP CHECK	38
Vent Terminal Location	20	Air Filter Inspection/Removal	39
Venting Configurations	23	Heat Exchanger Removal	40
Vertical Venting	24	MAINTENANCE	41
Horizontal Venting	26	Suggested Minimum Maintenance	
Outdoor Installation	29	Schedule	41
CONTROLS	30	APPENDIX	42
Ignition Control Module	30	Inside Combustion Air Contamination	42
Digital Temperature Control (Optional)	30	Important Instructions for the	
High Limit (Manual Reset)	30	Commonwealth of Massachusetts	43
High Limit — Auto Reset (Optional)	30		
Flow Switch	31		
High and Low Gas Pressure Switches			
(Optional)	31		
Low Water Cut Off (Optional)	31		

WARNINGS — Pay Attention to These Terms

DANGER:	Indicates the presence of immediate hazards which will cause severe personal injury, death or substantial property damage if ignored.
WARNING:	Indicates the presence of hazards or unsafe practices which could cause severe personal injury, death or substantial property damage if ignored.
CAUTION:	Indicates the presence of hazards or unsafe practices which could cause minor personal injury or product or property damage if ignored.
NOTE:	Indicates special instructions on installation, operation, or maintenance which are important but not related to personal injury hazards.

DANGER: Make sure the gas on which the heater will operate is the same type as that specified on the heater rating plate.

WARNING: Should overheating occur or the gas supply valve fail to shut, do not turn off or disconnect the electrical supply to the heater. Instead, shut off the gas supply at a location external to the heater.

WARNING: Risk of electrical shock. More than one disconnect switch may be required to deenergize the equipment before servicing.

WARNING: This unit contains refractory ceramic fiber (RCF) insulation in the combustion chamber. RCF, as manufactured, does not contain respirable crystalline silica. However, following sustained exposure to very high temperatures (>2192F), the RCF can transform into crystalline silica (cristabolite). The International Agency for Research on Cancer (IARC) has classified the inhalation of crystalline silica (cristabolite) as carcinogenic to humans.

When removing the burners or heat exchangers, take precautions to avoid creating airborne dust and avoid inhaling airborne fibers. When cleaning spills, use wet sweeping or High Efficiency Particulate Air (HEPA) filtered vacuum to minimize airborne dust. Use feasible engineering controls such as local exhaust ventilation or dust collecting systems to minimize airborne dust. Wear appropriate personal protective equipment including gloves, safety glasses with side shields, and appropriate NIOSH certified respiratory protection, to avoid inhalation of airborne dust and airborne fiber particles.

WARNING: To minimize the possibility of improper operation, serious personal injury, fire, or damage to the heater:

- Always keep the area around the heater free of combustible materials, gasoline, and other flammable liquids and vapors.
- Heater should never be covered or have any blockage to the flow of fresh air to the heater.

WARNING: Do not use this heater if any part has been under water. Immediately call a qualified service technician to inspect the heater and to replace any part of the control system and any gas control which has been under water.

CAUTION: Operation of this heater in low-temperature systems requires special piping. Harmful internal condensation will occur if the inlet water temperature does not exceed 105°F. Warranty claims will be denied when condensation occurs.

CAUTION: If this heater is to be installed above radiation level, it must be provided with a low water cut-off device at the time of heater installation.

CAUTION: If this heater is to be installed in a negative or positive pressure equipment room, there are special installation requirements. Consult factory for details.

CAUTION: This heater requires forced water circulation when the burner is operating. See minimum and maximum flow rates. Severe damage will occur if the heater is operated without proper water flow circulation.

BEFORE INSTALLATION

Raypak strongly recommends that this manual be reviewed thoroughly before installing your Hi Delta heater. Please review the General Safety information before installing the heater. Factory warranty does not apply to heaters that have been improperly installed or operated (refer to the warranty at the back of this manual). Installation and service must be performed by a qualified installer, service agency or the gas supplier. If, after reviewing this manual, you still have questions which this manual does not answer, please contact your local Raypak representative or visit our website at www.raypak.com.

Thank you for purchasing a Raypak product. We hope you will be satisfied with the high quality and durability of our equipment.

Product Receipt

WARNING: Pump motors should NOT be supported by any type of stand or support from above due to possible misalignment of pump and motor which may occur.

On receipt of your heater it is suggested that you visually check for external damage to the shipping crate. If the crate is damaged, make a note to that effect on the Bill of Lading when signing for the shipment. Next, remove the heater from the shipping packaging. Report any damage to the carrier immediately.

On occasion, items are shipped loose. Be sure that you receive the correct number of packages as indicated on the Bill of Lading.

Claims for shortages and damages must be filed with the carrier by consignee. Permission to return goods must be received from the factory prior to shipping. Goods returned to the factory without an authorized Returned Goods Receipt number will not be accepted. All returned goods are subject to a restocking charge.

When ordering parts, you must specify the model and serial number of the heater. When ordering under warranty conditions, you must also specify the date of installation.

Purchased parts are subject to replacement only under the manufacturer's warranty. Debits for defective replacement parts will not be accepted. Parts will be replaced in kind only per Raypak's standard warranties.

Model Identification

The model identification number and heater serial number are found on the heater data plate located on the right side jacket of the heater. The model number will have the form WH1-HD201 or similar depending on the heater size and configuration. The first character of the model number identifies application (WH = Hot Water Supply System). The second character identifies the firing mode (1 = On/Off firing). The next three places identify the size of the heater.

Ratings and Certifications

Standards:

- Industrial and Commercial Gas-Fired Package Heaters, CAN 3.1 - latest edition
- Gas Water Heaters, ANSI Z21.10.3 • CSA 4.3 - latest edition
- Low-lead content (<.25%) CSA-certified

All Raypak heaters are National Board Registered, and design-certified and tested by the Canadian Standards Association (CSA) for the U.S. and Canada. Each heater is constructed in accordance with Section IV of the American Society of Mechanical Engineers (ASME) Heater Pressure Vessel Code and bears the ASME HLW stamp. The heater also complies with the latest edition of ASHRAE 90.1 Standard.

WARNING: Altering any Raypak pressure vessel by installing replacement heat exchangers, tube bundle headers, or any ASME parts not manufactured and/or approved by Raypak will instantly void the ASME and CSA ratings of the vessel and any Raypak warranty on the vessel. Altering the ASME or CSA ratings of the vessel also violates national, state, and local approval codes.

Installations at Elevation

Rated inputs are suitable for up to 2000 feet elevation without de-rate. Consult the Factory for installations at any altitude in excess of 2000 feet.

Component Locations

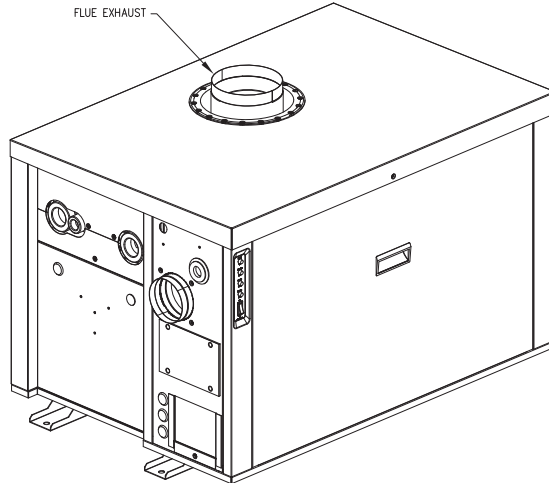

Fig. 1: Component Locations — Angle View

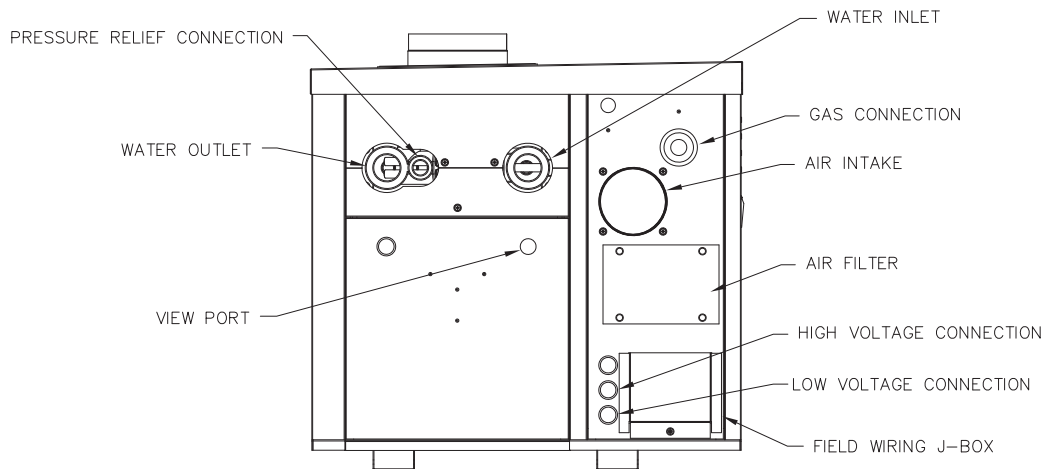

Fig. 2: Component Locations — Left Side

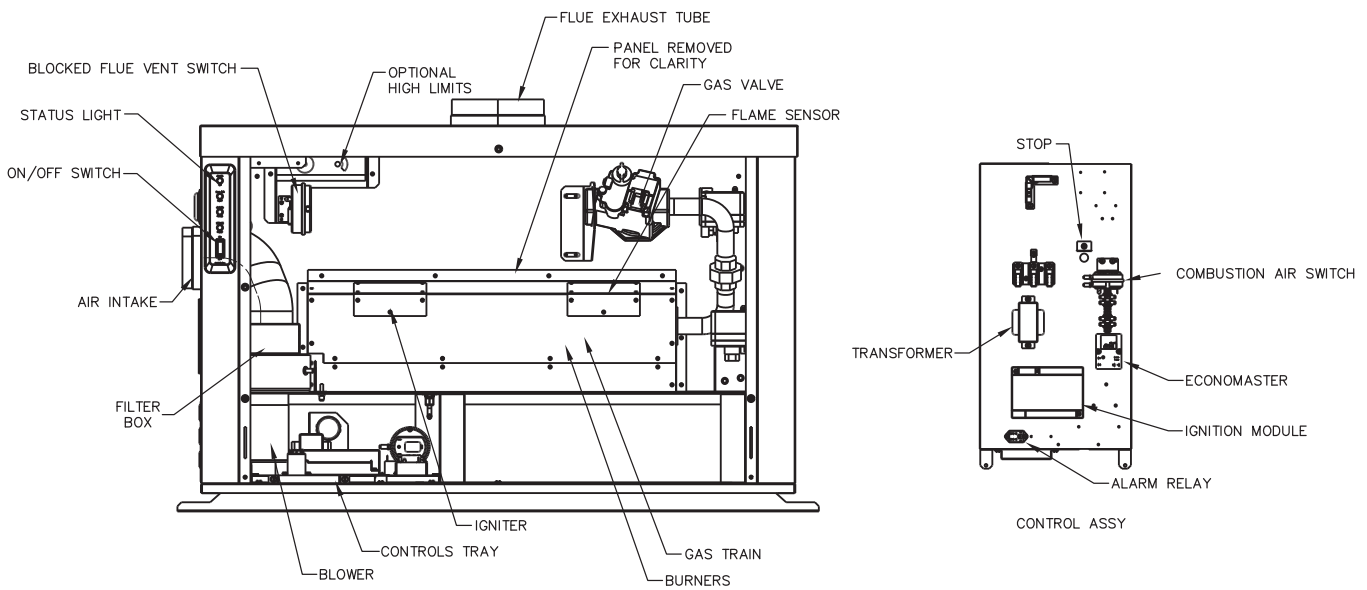

Fig. 3: Component Locations — Front (Panels removed for clarity)

General Information

Model No.	Quantity of Burners	Vent Size (in.)	
		Flue	Intake
HD101	2	4	4
HD151	3	4	
HD201	4	5	
HD251	5	5	
HD301	6	5	
HD401	8	6	

Table A: Basic Data

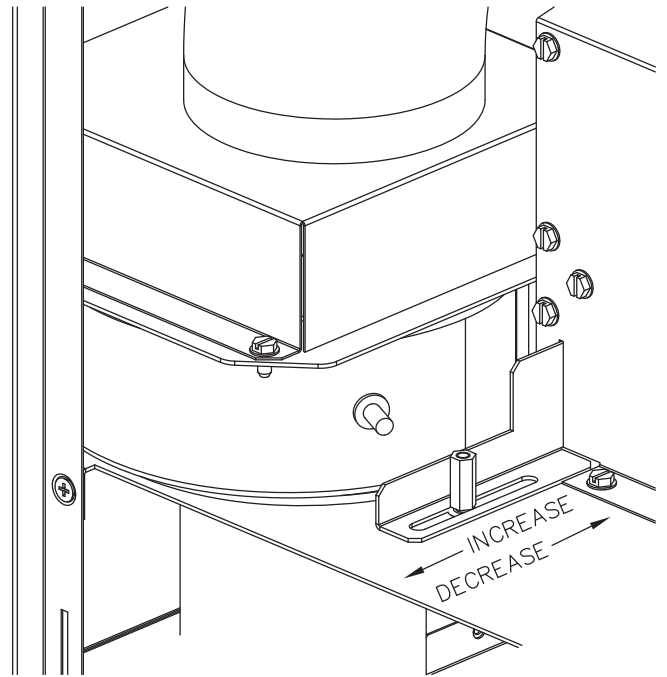

Fig. 4: Air Shutter Adjustment

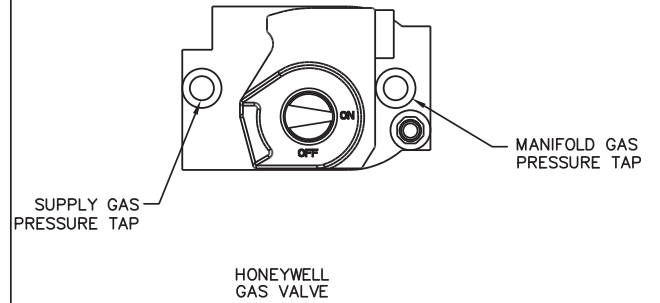
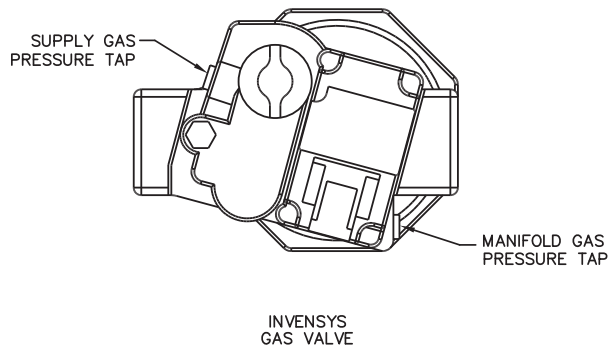

Fig. 5: Gas Valves

GENERAL SAFETY

To meet commercial hot water use needs, the high limit safety control on this water heater will shut off the main gas valve before the outlet temperature reaches 210°F. However, water temperatures over 125°F can cause instant severe burns or death from scalds. When supplying general purpose hot water, the recommended initial setting for the temperature control is 125°F.

Safety and energy conservation are factors to be considered when setting the water temperature on the thermostat. The most energy-efficient operation will result when the temperature setting is the lowest that satisfies the needs of the application.

Water temperature over 125°F can cause instant severe burns or death from scalds. Children, disabled and elderly are at highest risk of being scalded.

- Feel water before bathing or showering.
- Temperature limiting valves are available.

NOTE: When this water heater is supplying general purpose hot water for use by individuals, a thermostatically controlled mixing valve for reducing point of use water temperature is recommended to reduce the risk of scald injury. Contact a licensed plumber or the local plumbing authority for further information.

Maximum water temperatures occur just after the heater's burner has shut off. To determine the water temperature being delivered, turn on a hot water faucet and place a thermometer in the hot water stream and read the thermometer.

DANGER

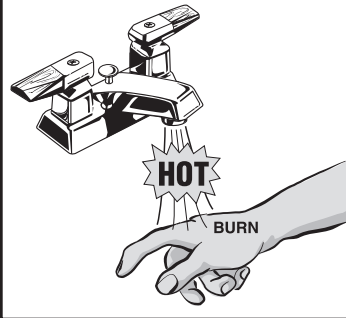

Water temperature over 125°F can cause instant severe burns or death from scalds.

Children, disabled, and elderly are at highest risk of being scalded.

See instruction manual before setting temperature at water heater.

Feel water before bathing or showering.

Temperature limiting valves are available, see manual.

Time/Temperature Relationships in Scalds

The following chart details the relationship of water temperature and time with regard to scald injury and may be used as a guide in determining the safest water temperature for your applications.

Water Temp.	Time to Produce Serious Burn
120°F	More than 5 minutes
125°F	1-1/2 to 2 minutes
130°F	About 30 seconds
135°F	About 10 seconds
140°F	Less than 5 seconds
145°F	Less than 3 seconds
150°F	About 1-1/2 seconds
155°F	About 1 second

Table courtesy of The Shriners Burn Institute

Table B: Time to Produce Serious Burn

INSTALLATION

Installation Codes

Installations must follow these codes:

- Local, state, provincial, and national codes, laws, regulations and ordinances.
- National Fuel Gas Code, ANSI Z223.1- latest edition (NFGC).
- National Electrical Code, ANSI/NFPA 70 - latest edition (NEC).
- For Canada only: CAN/CGA B149 Installation Code (B149) and C.S.A. C22. 1 C.E.C. Part 1 (C22. 1).

CAUTION: Hotter water increases the risk of scalding! There is a hot water scald potential if the thermostat is set too high.

Equipment Base

The heater should be mounted on a level, structurally sound surface. The heater is approved for installation on a combustible surface but must NEVER be installed on carpeting. Gas-fueled equipment installed in enclosed parking garages must be located at least 18 in. above the floor.

CAUTION: The heater should be located in an area where water leakage will not result in damage to the area adjacent to the appliance or to the structure. When such locations cannot be avoided, it is recommended that a suitable catch pan, adequately drained, be installed under the appliance. The pan must not restrict air flow.

In addition, the heater shall be installed such that the gas ignition system components are protected from water (dripping, spraying, rain, etc.) during appliance operation or service (circulator replacement, control replacement, etc.).

WARNING: This product must be installed by a licensed plumber or gas fitter when installed within the Commonwealth of Massachusetts.

Clearances

Indoor/Closet Installations

Heater Side	Minimum Installed Service Clearance
Front	24"
Rear	2"
Floor*	0"
Top	24"
Left**	12"
Right**	6"
Water Side	24"

*DO NOT install on carpeting.

**When water connections are on other side.

Table C: Clearances — Indoor/Closet Installations

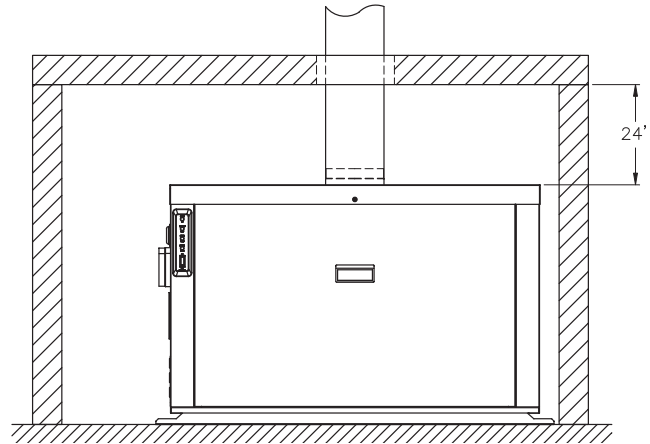
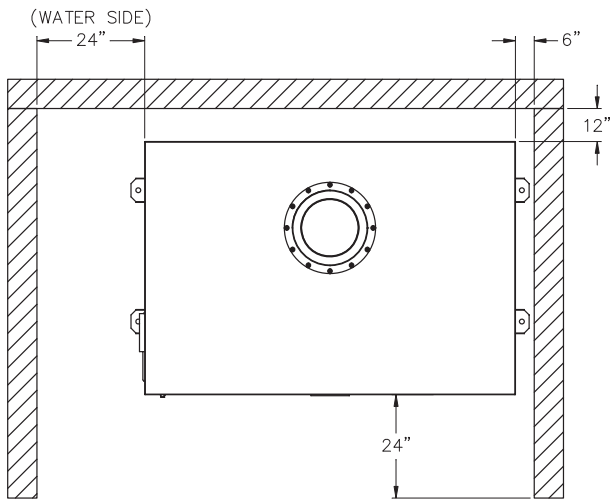

Fig. 6: Minimum Installed Service Clearances — Indoor/Closet Installations

CAUTION: Service clearances less than the minimums may require removal of the heater to service either the heat exchanger or the burners.

The heater must be installed in a manner that will enable the heater to be serviced without removing any structure around the heater.

Outdoor Installations

These heaters are design-certified for outdoor installation. Heaters must not be installed under an overhang unless clearances are in accordance with local installation codes and the requirements of the gas supplier. Three sides must be open in the area under the over-

hang. Roof water drainage must be diverted away from heaters installed under overhangs.

Heater Side	Minimum Installed Service Clearance
Front	24"
Rear	12"
Top	Unobstructed
Other Side	36"
Water Side	36"

Table D: Clearances — Outdoor Installations

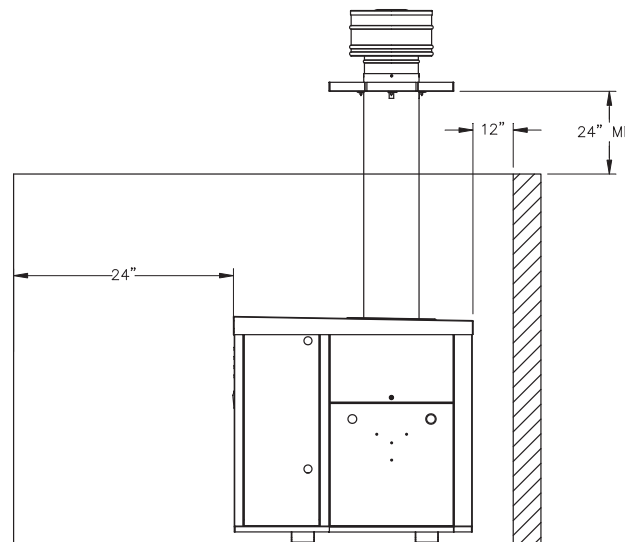
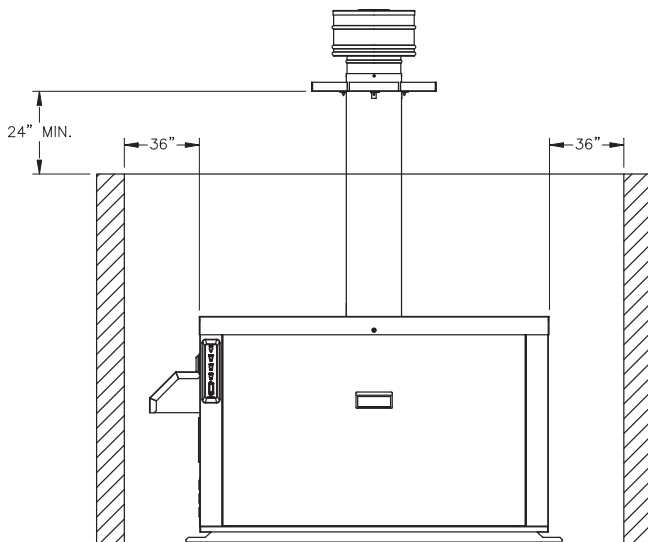

Fig. 7: Minimum Installed Service Clearance — Outdoor Installations

These clearances are required when the outdoor vent cap is used. If installing the heater outdoors with a vent stack, the indoor clearances may be utilized.

The combustion air intake hood **MUST** be used for outdoor installations. The hood is shipped loose and installed on the side of the heater over the filter box at the job site.

Combustion and Ventilation Air

Combustion Air Filter

This heater is supplied with an integral combustion air filter. This filter will reduce the amount of particulates passed through the combustion system and heat exchanger but will not protect against chemical inside air contamination (See Appendix). The filter must be checked periodically to verify that adequate combustion air is being supplied to the heater. See the Maintenance section of this manual for information on checking the filter and establishing service intervals.

Indoor Units

The heater must be supplied with sufficient quantities of non-contaminated air to support proper combustion and equipment ventilation. Combustion air can be supplied via conventional means where combustion air is drawn from the area immediately surrounding the heater, or via direct vent, where combustion air is drawn directly from outside. All installations must comply with the requirements of the NFGC (U.S.) and B149 (Canada), and all local codes.

CAUTION: Combustion air must not be contaminated by corrosive chemical fumes which can damage the heater and void the warranty. (See the Appendix.)

Direct Combustion Air

If outside air is drawn through the intake pipe directly to the unit for combustion:

1. Install combustion air direct vent in accordance with the venting section of this manual.
2. Provide adequate ventilation of the space occupied by the heater(s) by an opening(s) for ventilation air at the highest practical point communicating with the outdoors. The total cross-sectional area shall be at least 1 in.² of free

area per 20,000 BTUH (111 mm² per kW) of total input rating of all equipment in the room when the opening is communicating directly with the outdoors or through vertical duct(s). The total cross-sectional area shall be at least 1 in.² of free area per 10,000 BTUH (222 mm² per kW) of total input rating of all equipment in the room when the opening is communicating with the outdoors through horizontal duct(s).

3. In cold climates, and to mitigate potential freeze-up, Raypak highly recommends the installation of a motorized sealed damper to prevent the circulation of cold air through the heater during non-operating hours.

Conventional Combustion Air Supply

U.S. Installations

All Air from Inside the Building

The confined space shall be provided with **TWO** permanent openings communicating directly with an additional room(s) of sufficient volume so that the combined volume of all spaces meets the criteria for an unconfined space. The total input of all gas utilization equipment installed in the combined space shall be considered in making this determination. Each opening shall have a minimum free area of 1 in.² per 1,000 BTUH (22 cm² per kW) of the total input rating of all gas utilization equipment in the confined space, but not less than 100 in.² (645 cm²). One opening shall commence within 6-3/4 in. of the top, and one opening shall commence within 6-3/4 in. of the bottom, of the enclosure. The minimum dimension of air openings shall be not less than 3 in. (8 cm) in any direction.

All Air from Outdoors

The confined space shall communicate with the outdoors in accordance with methods 1 or 2 below. The minimum dimension of air openings shall not be less than 3 in. (8 cm) in any direction. Where ducts are used, they shall be of the same cross-sectional area as the free area of the openings to which they connect.

1. **Two permanent openings**, one commencing within 12 in. (30 cm) of the top, and one commencing within 12 in. (30 cm) of the bottom, of the enclosure shall be provided. The openings shall communicate directly, or by ducts, with the outdoors or spaces (crawl or attic) that freely communicate with the outdoors.

- a. Where directly communicating with the outdoors or where communicating to the outdoors through vertical ducts, each opening shall have a minimum free area of 1 in.² per 4000 BTUH (5.5 cm² per kW) of total input rating of all equipment in the enclosure.
 - b. Where communicating with the outdoors through horizontal ducts, each opening shall have a minimum free area of 1 in.² per 2000 BTUH (11 cm² per kW) of total input rating of all equipment in the enclosure.
2. **One permanent opening**, commencing within 12 in. (30 cm) of the top of the enclosure, shall be permitted where the equipment has clearances of at least 1 in. (2.5 cm) from the sides and back and 6 in. (16 cm) from the front of the appliance. The opening shall directly communicate with the outdoors or shall communicate through a vertical or horizontal duct to the outdoors or spaces (crawl or attic) that freely communicate with the outdoors, and shall have a minimum free area of:
- a. 1 in.² per 3000 BTUH (7 cm² per kW) of the total input rating of all equipment located in the enclosure, and
 - b. Not less than the sum of the areas of all vent connectors in the confined space.

WARNING: Do not use one permanent opening method if the equipment room is under negative pressure conditions or the equipment is common vented with other gas-fired appliances.

Installations in Canada

CAUTION: All combustion air must be drawn from the air outside of the building; the mechanical equipment room must communicate directly with the outdoors.

1. Ventilation of the space occupied by the heater shall be provided by an opening(s) for ventilation air at the highest practical point communicating with outdoors. The total cross-sectional area of such an opening(s) shall be at least 10% of the area required in (2) and (3), but in no case shall the cross-sectional area be less than 10 in.² (6500 mm²).
2. For heaters using a barometric damper in the vent system, and when air supply is provided by natural

air flow from the outdoors there shall be a permanent air supply opening(s) having a cross section area of not less than 1 in.² per 7000 BTUH (310 mm² per kW) up to and including 1 million BTUH, plus 1 in.² per 14000 BTUH (155 mm² per kW) in excess of 1 million BTUH. This opening(s) shall be either located at or ducted to a point not more than 18 in. (450 mm) nor less than 6 in. (150 mm) above the floor level. The duct can also "Goose Neck" through the roof. The duct is preferred straight down 18" from floor, but do not place near piping. This air supply opening requirement shall be in addition to the air opening for ventilation air required in (1).

3. For heaters not using a barometric damper in the vent system, and when air supply is provided by natural air flow from outdoors and there is no flue gas dilution device installed in the same space, in addition to the opening for ventilation air required in (1), there shall be a permanent air supply opening(s) having a total cross-sectional area of not less than 1 in.² for each 30,000 BTUH (70 mm² per kW) of total rated input of the burner(s), and the location of the opening(s) shall not interfere with the intended purpose of the opening(s) for ventilation air referred to (1). This opening(s) can be ducted to a point not more than 18 in. (450 mm) nor less than 6 in. (150 mm) above the floor level. The duct can also "Goose Neck" through the roof. The duct is preferred to be straight down 18" from floor, but do not place near piping.
4. Refer to the latest version of the B149 for additional information.

Water Piping

General

The heater should be located so that any water leaks will not cause damage to the adjacent area or structures.

CAUTION: This heater requires forced water circulation when the burner is operating. See Table E for minimum and maximum flow rates and water pump selection. The pump must be interlocked with the heater to prevent heater operation without water circulation.

Reversing Water Connections

Follow these instructions to change the water connections from the left-hand side (standard) to the right-hand side.

1. Disconnect all electrical power from the heater (if applicable).
2. Label all electrical connections and conduit lines. This may include the flow switch, low water cut-off probe and/or pump.
3. Disconnect or isolate the main gas pipe from the heater (if applicable).
4. Remove both in/out and return header access panels by removing all sheet metal screws.
5. Remove all plumbing fittings to the header. This will include both inlet and outlet water pipe unions and the pressure relief valve and drain piping.
6. Remove limits, control bulbs and/or sensors.
7. Remove the six flange nuts and the in/out header from the left-hand side.
8. Remove the six flange nuts and the return header from the right-hand side.
9. Remove the header stud bolts from each tube sheet.
10. Reverse the headers and stud bolts to the new location.
11. Install NEW red beveled O-rings flush against both tube sheets with the bevel facing outward.
12. Push the header firmly against the O-rings. Install and tighten the flange nuts onto the stud bolts until finger tight.
13. Slowly tighten the flange nuts, starting from the center nut (number 1) in Fig. 8 and working sequentially around the header as indicated. Torque all nuts to 25 ft/lb. **DO NOT OVER-TIGHTEN.**
14. Re-route the capillary(s), wiring, etc., to the new location, adding thermal paste and shim to the capillary well.

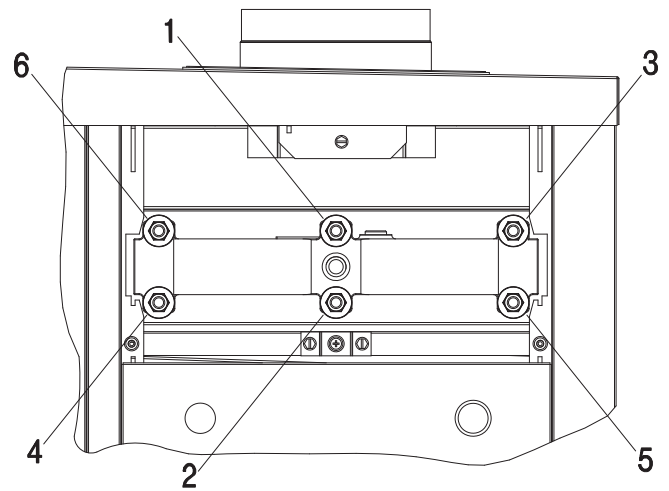

Fig. 8: Torque Sequence

Relief Valve Piping

WARNING: Pressure relief valve discharge piping must be piped near the floor and close to a drain to eliminate the potential of severe burns. Do not pipe to any area where freezing could occur. Refer to local codes.

Hydrostatic Test

Unlike many other types of heaters, Raypak heaters do not require hydrostatic testing prior to being placed in operation. The heat exchanger has already been factory-tested and is rated for 160 PSI maximum operating pressure. However, Raypak does recommend hydrostatically testing the piping connections to the heater and the rest of the system prior to operation. Raypak recommends conducting the hydrostatic test before connecting gas piping or electrical supply.

Leaks must be repaired at once to prevent damage to the heater. NEVER use petroleum-based stop-leak compounds.

Low Temperature System

Heater requires minimum inlet temperature of 105°F. Consult the following sections for piping details.

Temperature & Pressure Gauge

The temperature and pressure gauge is shipped loose for field installation.

Domestic Hot Water Piping

When designing the water piping system for domestic water applications, water hardness should be considered. Table E indicates the suggested flow rates for soft, medium and hard water. Hardness is specified as grains per gallon.

Model No.	Input MBTUH	Output MBTUH	Soft (3–4 grains per gallon)***					Medium (5–15 grains per gallon)					Hard* (16–25** grains per gallon)				
			ΔT	gpm	ΔP	MTS	SHL	ΔT	gpm	ΔP	MTS	SHL	ΔT	gpm	ΔP	MTS	SHL
HD101	100	83	8	20	1.8	1-1/2	3.8	6	26	3.0	1-1/2	6.3	4	45	9.2	1-1/2	18.0
HD151	150	125	12	20	1.8	1-1/2	3.8	10	26	3.1	1-1/2	6.3	6	45	9.2	1-1/2	18.1
HD201	199	165	17	20	1.9	1-1/2	3.9	13	26	3.2	1-1/2	6.4	7	45	9.4	1-1/2	18.2
HD251	250	208	21	20	1.9	1-1/2	3.9	16	26	3.2	1-1/2	6.5	9	45	9.6	1-1/2	18.5
HD301	299	248	25	20	1.9	1-1/2	3.9	19	26	3.2	1-1/2	6.5	11	45	9.8	1-1/2	18.7
HD401	399	331	33	20	2.0	1-1/2	4.0	25	26	3.3	1-1/2	6.6	15	45	10.3	1-1/2	19.1

ΔT = Temperature rise, °F.

ΔP = Pressure drop through heat exchanger, ft.

SHL = System head loss, ft. (System head loss is based on the heater and tank placed no more than 5 feet apart and 50 feet equivalent length of tubing and fittings.)

gpm = Gallons per minute, flow rate.

MTS = Minimum tubing size.

*Must utilize optional cupro-nickel tubes.

**With Hard Water (16-25 grains per gallon), the operating control must be set no higher than 130°F for scale free operation. For operating temperatures above 130°F, a water softener must be utilized.

***Care should be given to prevent over-softening of the water as over-softened water can become aggressive. Cupro-nickel tubes are recommended for water softened below 5 grains per gallon.

Table E: Domestic Water Heater Flow Rate Requirements

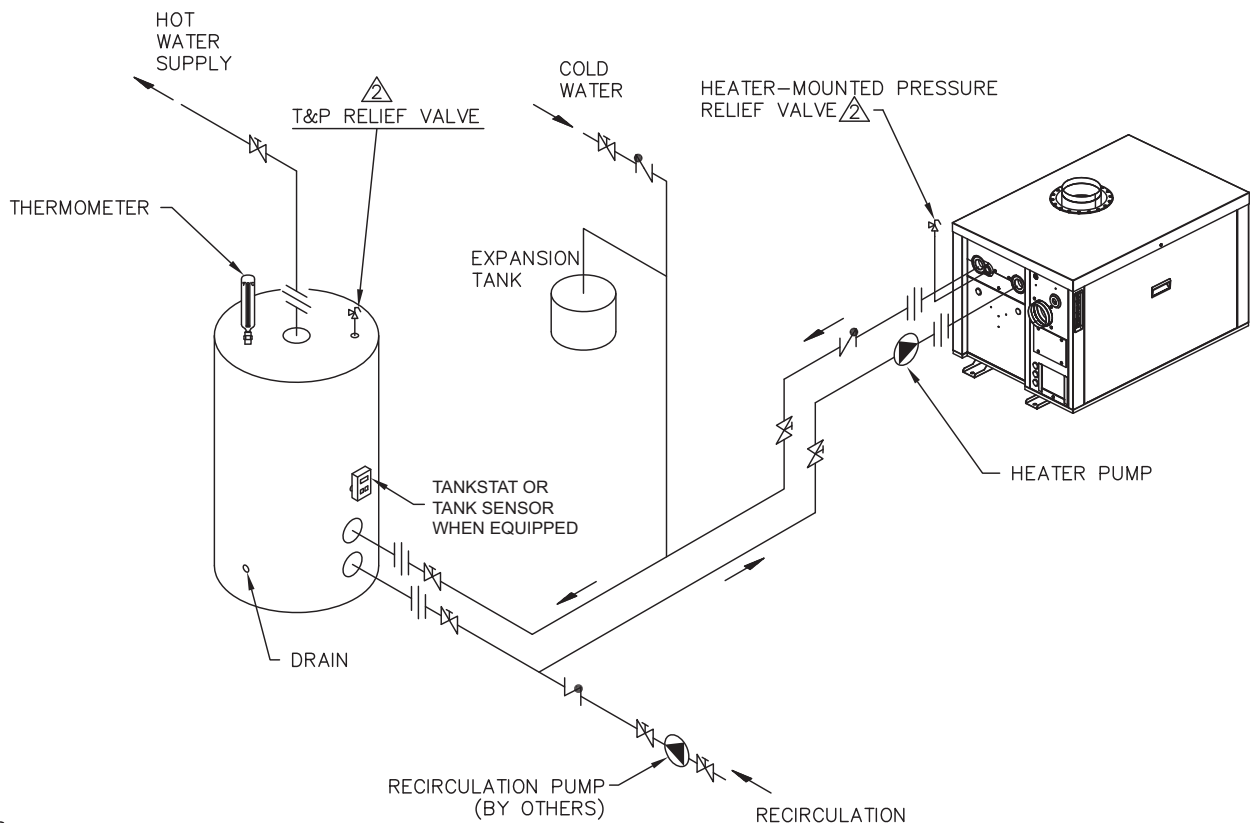

NOTES:

1. PLUMB SWING CHECK VALVE IN GRAVITY-CLOSED POSITION.

 PIPE ALL RELIEF VALVES TO DRAIN, OR AS LOCAL CODES REQUIRE.

Fig. 9: Single Heater — Domestic Hot Water with One Storage Tank

Gas Supply

DANGER: Make sure the gas on which the heater will operate is the same type as specified on the heater's rating plate.

Gas piping must have a sediment trap ahead of the heater gas controls, and a manual shut-off valve located outside the heater jacket. A pounds to inches regulator must be installed to reduce the natural gas supply pressure to under 10.5 in. WC (13.0 in. WC for propane gas). The regulator should be placed a minimum distance of 10 times the pipe diameter upstream of the heater gas controls. All gas piping must be tested after installation in accordance with local codes. The heater and its gas connection must be leak-tested before placing it in operation.

Gas Supply Connection

CAUTION: The heater and its manual shutoff valve must be disconnected from the gas supply during any pressure testing of the gas supply system at test pressures in excess of 1/2 psi (3.45 kPa). The heater must be isolated from the gas supply piping system by closing the manual shutoff valve during any pressure testing of the gas supply piping system at test pressures equal to or less than 1/2 psi. Relieve test pressure in the gas supply line before reconnecting the heater and its manual shut off valve to the gas supply line. **FAILURE TO FOLLOW THIS PROCEDURE MAY DAMAGE THE GAS VALVES.** Over pressurized gas valves are not covered by warranty. The heater and its gas connections shall be leak tested before placing the appliance in operation. Use soapy water for leak test: **DO NOT** use open flame.

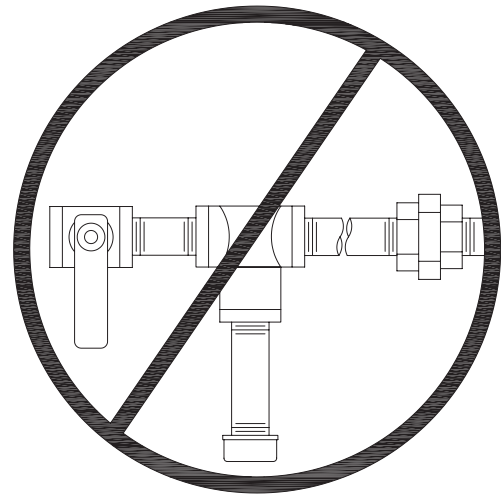
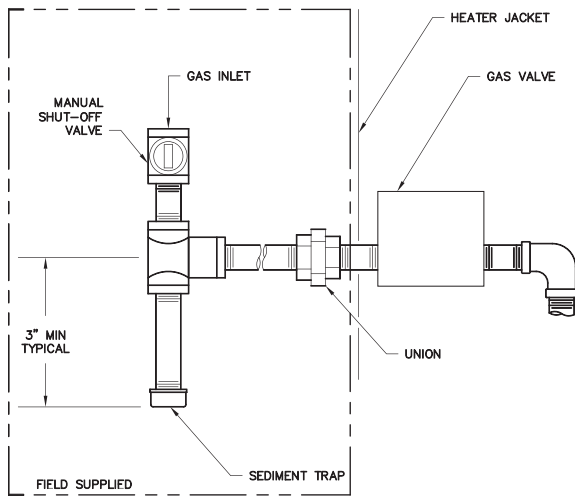

Fig. 10: Sediment Trap Orientation

CAUTION: Do not use Teflon tape on gas line pipe thread. A pipe compound rated for use with gas systems is recommended. Apply sparingly only on male pipe ends.

CAUTION: Support gas supply piping with hangers, not by the heater or its accessories. Ensure the gas piping is protected from physical damage and freezing where required.

Gas Supply Pressure

A minimum of 4 in. WC and a maximum of 10.5 in. WC upstream gas pressure is required under load and no load conditions for natural gas. A minimum of 11 in. WC and a maximum of 13 in. WC is required for propane gas. The gas pressure regulator supplied on the heater is for low pressure service. If upstream pressure exceeds 14 in. WC, an intermediate gas pressure regulator, of the lockup type, must be installed.

When connecting additional gas utilization equipment to the gas piping system, the existing piping must be checked to determine if it has adequate capacity.

Firing Stage	Gas Valve	Gas Type	
		Natural +/- 0.1"WC	LP/Propane +/- 0.1"WC
Full Fire	Invensys	3.4" WC	
	Honeywell	3.1" WC	9.6" WC

Table F: Pressure at Gas Valve Outlet Tap

Gas Pressure Regulator

The gas valve pressure regulator on the heater is nominally preset at 3.3" (3.0" on HD401) WC for natural gas, and 9.6" WC for propane gas manifold pressure. The pressure at the gas valve outlet tap, measured with a manometer, while in operation should be as indicated in Table F. If an adjustment is needed, turn the adjustment screw clockwise to increase pressure or counter-clockwise to decrease pressure.

Electrical Power Connections

Installations must follow these codes:

- National Electrical Code and any other national, state, provincial or local codes or regulations having jurisdiction
- Safety wiring must be N.E.C. Class 1
- Heater must be electrically grounded as required by N.E.C.
- In Canada, C22.1

The heater is wired for 120 VAC, less than 12 AMPS. The voltage is indicated on the tie-in leads. Consult the wiring diagram shipped with the heater in the instruction packet. The remote tank control stat, thermostat, or electronic heater control as applicable, may be connected to stage selector terminal (See wiring diagram). 24 Volts are supplied to this connection through the heater transformer. **DO NOT attach line voltage to the stage connections.** Before starting the heater check to ensure proper voltage to the heater and pump.

WARNING: Connecting line voltage to the stage connection terminal block will cause damage to the unit that is not covered by warranty.

Model No.	Input (KBTUH)	3/4"		1"		1-1/4"		1-1/2"	
		N	P	N	P	N	P	N	P
HD101	100	105	385	340					
HD151	150	50	180	160	530	600			
HD201	199	30	95	95	355	360			
HD251	250	20	50	60	230	240			
HD301	299	15	35	45	170	170	550	360	
HD401	399	5	20	25	80	100	365	210	

Table G: Maximum Equivalent Pipe Length

Natural gas – 1,000 BTUH per ft³, .60 specific gravity at 0.5 in. WC pressure drop
 Propane gas – 2,500 BTUH per ft³, 1.50 specific gravity at 0.5 in. WC pressure drop

Install a separate disconnect means for each load. Use appropriate-sized wire as defined by NEC, CSA and/or local code. All primary wiring should be 125% of minimum rating.

It is strongly recommended that all individually-powered control modules and the heater should be supplied from the same power source.

Surge Protection

Microprocessor-based and solid state controls are vulnerable to damage from voltage and amperage fluctuations in the power supply. All sensitive control components should be protected by a suitable commercial-grade surge protection device.

If any of the original wire as supplied with the heater must be replaced, it must be replaced with 105°C wire or its equivalent.

Check the Power Source

WARNING: Using a volt-ohm meter (VOM), check the following voltages at the terminal block inside the unit. Make sure proper polarity is followed and house ground is proven.

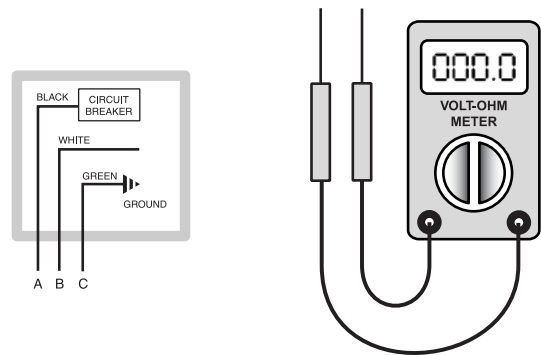

AC = 108 Volts AC Minimum, 132 Volts AC MAX
 AB = 108 Volts AC Minimum, 132 Volts AC MAX
 BC = < 1 Volt AC

Fig. 11: Check Power Source

Making the Electrical Connections

Refer to Fig. 11 and the Wiring Diagram.

1. Verify circuit breaker is properly sized by referring to heater rating plate. A dedicated circuit breaker should be provided.
2. Turn off all power to the heater. Verify that power has been turned off by testing with a volt-ohm meter prior to working with any electrical connections or components.
3. Observe proper wire colors while making electrical connections. Many electronic controls are polarity sensitive. Components damaged by improper electrical installation are not covered by warranty.
4. Provide an external surge suppressor capable of maintaining system integrity.

5. Provide overload protection and a disconnect means for equipment serviceability as required by local and state code.
6. Install heater controls, thermostats, or building management systems in accordance with the applicable manufacturer's instructions.
7. Conduit should not be used as the ground. There must be a solidly wired ground.

NOTE: A grounding electrode conductor shall be used to connect the equipment grounding conductors, the equipment enclosures, and the grounded service conductor to the grounding electrode.

Electrical Connections — Domestic Hot Water

DANGER—SHOCK HAZARD: Make sure electrical power to the heater is disconnected to avoid potential serious injury or damage to components.

CAUTION: Label all wires prior to disconnection when servicing controls. Wiring errors can cause improper and dangerous operation. Verify proper operation after servicing.

NOTE: Minimum 18 AWG, 105°C, stranded wire must be used for all low voltage (less than 30 volts) external connections to the unit. Solid conductors should not be used because they can cause excessive tension on contact points. Install conduit as appropriate. All high voltage wires must be the same size (105°C, stranded wire) as the ones on the unit or larger.

Installer action is required to electrically enable your Hi Delta heater to operate after making the power connections. You must use Terminal Block connections 1 through 4 for the temperature controller, as shown in Fig. 12. This will be done based on the controller option selected with your heater order.

For operation with a Temp-Tracker controller, refer to the Temp-Tracker Installation and Operating Instructions, Raypak Catalog number 5000.66 (P/N 241177).

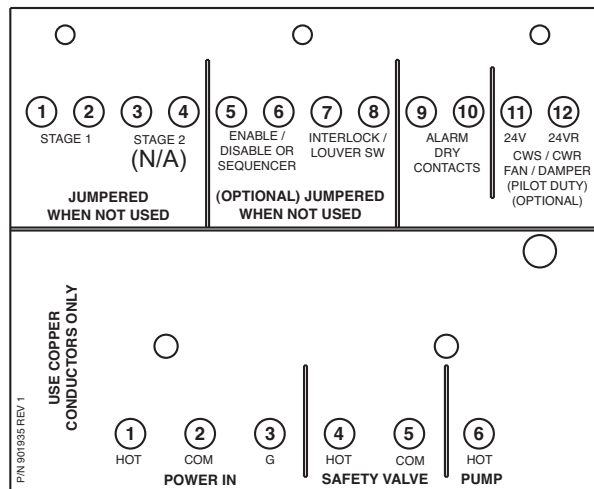
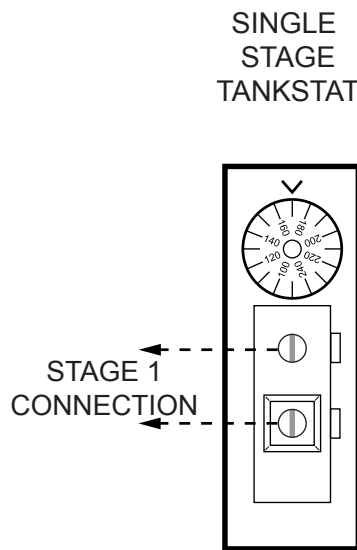

Fig. 12: Terminal Block Connections

Consult the wiring diagram shipped with the heater in the instruction packet. The Stage 1 connections are for the remote tank control through the heaters 24 volt transformer. **DO NOT attach line voltage to the Stage 1 connection.** Before starting heater, check to ensure proper voltage to heater and pump.



ATTACH STAGE 1 CONNECTIONS ON HEATER TO THE SINGLE STAGE TANKSTAT AS SHOWN IN THE DIAGRAM ABOVE.

Fig. 13: Single Stage Tankstat

Heater must be electrically grounded in accordance with NEC and C22.1(in Canada).

NOTES:

1. Field installed ground to inside of junction box.
2. If any of the original wire as supplied with the heater must be replaced, it must be replaced with 105°C wire or its equivalent.

Venting

General

CAUTION: Proper installation of flue venting is critical for the safe and efficient operation of the heater.

Definition of Appliance Categories

Heaters are divided into four categories based on the pressure produced in the exhaust and the likelihood of condensate production in the vent.

Category I. A heater which operates with a non-positive vent static pressure and with a vent gas temperature that avoids excessive condensate production in the vent.

Category II. A heater which operates with a non-positive vent static pressure and with a vent gas temperature that may cause excessive condensate production in the vent.

Category III. A heater which operates with a positive vent pressure and with a vent gas temperature that avoids excessive condensate production in the vent.

Category IV. A heater which operates with a positive vent pressure and with a vent gas temperature that may cause excessive condensate production in the vent.

See Table H for appliance category requirements for the Hi Delta.

NOTE: For additional information on appliance categorization, see appropriate ANSI Z21 Standard and the NFGC (U.S.), or B149 (Canada), or applicable provisions of local building codes.

Determination of Appliance Category for Venting Purposes and Venting Arrangements

WARNING: Contact the manufacturer of the vent material if there is any question about the appliance categorization and suitability of a vent material for application on a Category III or IV vent system. Using improper venting materials can result in personal injury, death or property damage.

Barometric Damper

A barometric damper may be required when vent heights exceed 25 feet or when the draft is greater than -0.08 in. WC. In these installations, a barometric damper (single acting) is required.

The damper should be installed NO CLOSER than 18 in. from the discharge of the unit and no closer than 18 in. from a combustible ceiling. The damper can be installed in horizontal or vertical runs of vent pipe as necessary. Installation in a bull-head tee is acceptable as shown in the NFGC.

The weights on the damper should be adjusted per the damper manufacturer's instructions for proper operation, to maintain -0.01 to -0.08 in. WC, 12 in. from the heater outlet, at all firing conditions.

Support of Vent Stack

The weight of the vent stack or chimney must not rest on the heater vent connection. Support must be provided in compliance with applicable codes. The vent should also be supported to maintain proper clearances from combustible materials.

Use insulated vent pipe spacers where the vent passes through combustible roofs and walls.

Combustion Air Supply.	Exhaust Configuration	Venting Category	Certified Appliance Material	Combustion Air Inlet Material
From Inside Building (Non-Direct Venting)	Vertical Natural Draft Venting	I	Type B or any Category I Venting System ^{1,2}	
	Horizontal Thru-wall Venting	III	Stainless Steel (Gas Tight)	
From Outside Building (Direct Venting)	Vertical Venting	I	Type B or any Category I Venting System ^{1,2}	Galvanized Steel PVC ABS CPVC
	Horizontal Thru-wall Venting	III	Stainless Steel (Gas Tight)	

¹ As defined in the latest edition of the NFGC, or in Canada, the B149.

² Vent system must be double-wall.

Table H: Venting Category Requirements

Vent Terminal Location

NOTE: During winter months check the vent cap and make sure no blockage occurs from build up of snow.

1. Condensate can freeze on the vent cap. Frozen condensate on the vent cap can result in a blocked flue condition.
2. Give special attention to the location of the vent termination to avoid possibility of property damage or personal injury.
3. Gases may form a white vapor plume in winter. The plume could obstruct a window view if the termination is installed in close proximity to windows.
4. Prevailing winds, in combination with below freezing temperatures, can cause freezing of condensate and water/ice build-up on buildings, plants or roofs.
5. The bottom of the vent terminal and the air intake shall be located at least 12 in. above grade, including normal snow line.
6. Un-insulated single-wall metal vent pipe shall not be used.
7. Through-the-wall vents for Category II and IV appliances and non-categorized condensing appliances shall not terminate over public walkways or over an area where condensate or vapor could create a nuisance or hazard or could be detrimental to the operation of regulators, relief valves, or other equipment. Where local experience indicates that condensate is a problem with Category I and III appliances, this provision shall also apply.
8. Locate and guard vent termination to prevent accidental contact by people or pets.
9. DO NOT terminate vent in window well, stairwell, alcove, courtyard or other recessed area.
10. DO NOT terminate above any door, window, or gravity air intake. Condensate can freeze, causing ice formations.
11. Locate or guard vent to prevent condensate from damaging exterior finishes. Use a rust resistant sheet metal backing plate against brick or masonry surfaces.
12. DO NOT extend exposed vent pipe outside of building. Condensate could freeze and block vent pipe.

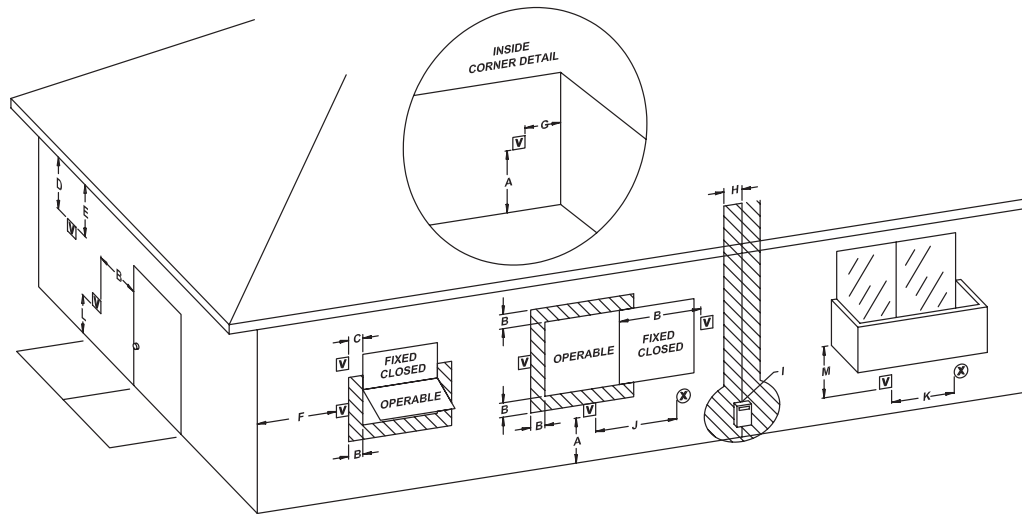

Fig. 14: Minimum Clearances from Vent/Air Inlet Terminations – Indoor and Outdoor Installations

		U.S. Installations¹	Canadian Installations²
A	Clearance above grade, veranda, porch, deck, or balcony	1 ft (30 cm)	1 ft (30 cm)
B	Clearance to window or door that may be opened	4 ft (1.2m) below or to side of opening; 1 foot (30 cm) above opening	3 ft (91 cm)
C	Clearance to permanently closed window	*	*
D	Vertical clearance to ventilated soffit located above the terminal within a horizontal distance of 2 ft (61cm) from the centerline of the terminal	5 ft (1.5m)	*
E	Clearance to unventilated soffit	*	*
F	Clearance to outside corner	*	*
G	Clearance to inside corner	6 ft (1.83m)	*
H	Clearance to each side of center line extended above meter/regulator assembly	*	3 ft (91 cm) within a height 15 ft above the meter/regulator assembly
I	Clearance to service regulator vent outlet	*	6 ft (1.83m)
J	Clearance to non-mechanical air supply inlet to building or the combustion air inlet to any other appliance	4 ft (1.2m) below or to side of opening; 1 ft (30 cm) above opening	3 ft (91 cm)
K	Clearance to mechanical air supply inlet	3 ft (91 cm) above if within 10 ft (3m) horizontally	6 ft (1.83m)
L	Clearance above paved sidewalk or paved driveway located on public property	7 ft (2.13m)	7 ft (2.13m) t
M	Clearance under veranda, porch, deck or balcony	*	12 in. (30 cm) TT

¹ In accordance with the current ANSI Z223.1/NFPA 54 National Fuel Gas Code

² In accordance with the current CAN/CSA-B149 Installation Codes

t Vent terminal shall not terminate directly above sidewalk or paved driveway located between 2 single family dwellings that serves both dwellings

TT Permitted only if veranda, porch, deck, or balcony is fully open on a minimum of two sides beneath the floor and top of terminal and underside of veranda, porch, deck or balcony is greater than 1 ft (30cm)

* Clearances in accordance with local installation codes and the requirements of the gas supplier

Table I: Vent/Air Inlet Termination Clearances

US Installations

Refer to latest edition of the National Fuel Gas Code.

Vent termination requirements are as follows:

- a) Vent must terminate at least four (4) feet below, four (4) feet horizontally, or one (1) foot above any door, window or gravity air inlet to the building.
- b) The vent must not be less than seven (7) feet above grade when located adjacent to public walkways.
- c) Terminate vent at least three (3) feet above any forced air inlet located within ten (10) feet.
- d) Vent must terminate at least four (4) feet horizontally, and in no case above or below unless four (4) feet horizontal distance is maintained, from electric meters, gas meters, regulators, and relief equipment.
- e) Terminate vent at least six (6) feet away from adjacent walls.
- f) DO NOT terminate vent closer than five (5) feet below roof overhang.
- g) The vent terminal of a direct vent appliance with an input over 50,000 BTUH per hour shall require a 12-inch vent terminal clearance.
- h) Terminate vent at least one (1) foot above grade, including normal snow line.
- i) Multiple direct vent installations require a four (4) foot clearance between vent caps.

Installations in Canada

Refer to latest edition of CAN/CGA-B149.

A vent shall not terminate:

- a) Directly above a paved sidewalk or driveway which is located between two single family dwellings and serves both dwellings.
- b) Less than 7 ft. (2.1m) above a paved sidewalk or paved driveway located on public property.
- c) Within 6 ft. (1.8m) of a mechanical air supply inlet to any building.
- d) Above a meter/regulator assembly within 3 ft. (914mm) horizontally of the vertical center-line of the regulator.
- e) Within 6 ft. (1.8m) of any gas service regulator vent outlet.
- f) Less than 1 ft. (305mm) above grade level.
- g) Within the 3 ft. (914mm) of a window or door which can be opened in any building, any non-mechanical air supply inlet to any building or the combustion air inlet of any other appliance.
- h) Underneath a verandah, porch or deck, unless
 - (i) the verandah, porch or deck is fully open on a minimum of two sides beneath the floor, and
 - (ii) the distance between the top of the vent termination and the underside of the verandah, porch or deck is greater than 1 ft. (30 cm).

Venting Installation Tips

Support piping:

- horizontal runs- at least every five (5) feet.
- vertical runs - use braces:
- under or near elbows

Follow items listed below to avoid personal injury or property damage.

- Cut nonmetallic intake pipe with fine-toothed hacksaw.
- Do not use nonmetallic intake pipe or fittings that are cracked or damaged.
- Do not use nonmetallic intake fittings if they are cut or altered.
- Do not drill holes, or use screws or rivets, in non-metallic intake pipe or fittings.

To make metallic vent joints:

- Do not install seams of vent pipe on bottom of runs.
- 100% Seal all joints and seams with high temperature silicone sealant.

WARNING: Examine the venting system at least once a year. Check all joints and vent pipe connections for tightness, corrosion or deterioration.

NOTE: The words "Flue Exhaust", "Flue" and "Exhaust Vent" are used interchangeably.

on, Venting of Equipment, of the latest edition of NFGC, or in Canada, B149 Installation Code for Gas Burning Appliances and Equipment, or applicable provisions of local building codes.

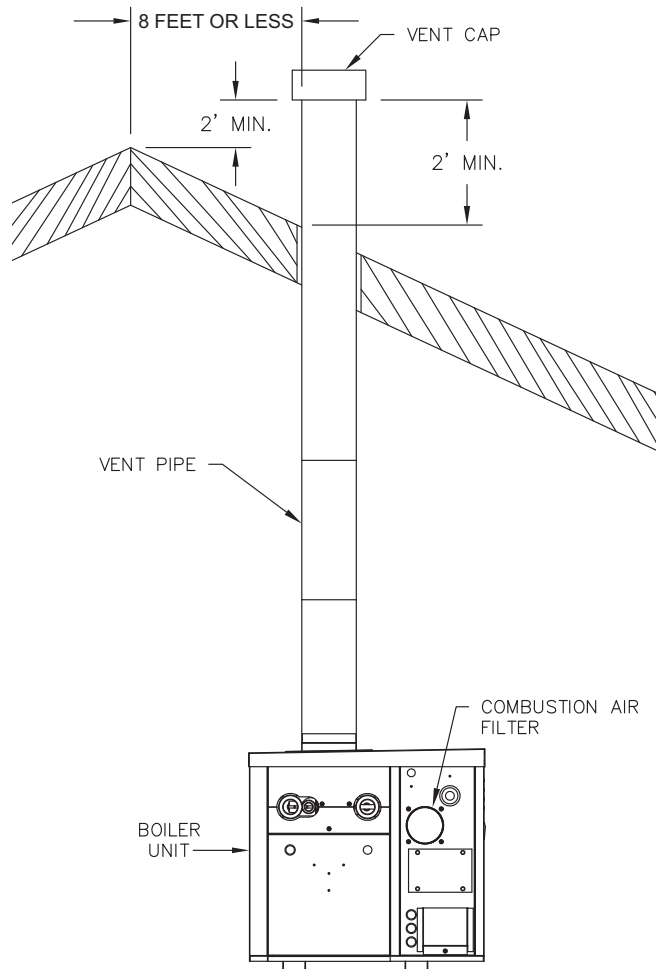

Fig. 15: Natural Draft Vertical Venting (Category I)

Venting Configurations

For heaters connected to gas vents or chimneys, vent installations shall be in accordance with the section

Model No.	Appliance Category	Certified Venting Material	Minimum Recommended Vent Size (inches)	Min./Max. Venting Length without Barometric Damper (feet)**		Air Inlet Max. Length (feet)
				Min.	Max.	
HD101 HD151	I	Type B or Equivalent ¹	4	6	25	100
HD201 HD251 HD301			5	(HD201) 6 (HD251) 6 (HD301) 11		
HD401			6	8		

**Vent lengths are based on a lateral length of 2 feet. Refer to the latest edition of the NFGC for further details. (ANSI Z223.1)

¹ Vent system must be double-wall.

Table J: Natural Draft Vertical Venting

Natural Draft Vertical Venting System Installation

Natural draft venting uses the natural buoyancy of the heated flue products to create a thermal driving head that expels the exhaust gases from the flue. The negative draft must be within the range of -0.01 in. to -0.08 in. WC as measured 12 in. from the appliance flue outlet to ensure proper operation. Vent material must be listed by a nationally recognized test agency.

The maximum and minimum venting length for Category I appliance shall be determined per the latest edition of the NFGC (U.S.) or B149 Installation Code (Canada).

The diameter of vent flue pipe should be sized according to Part 11 of the latest edition of the NFGC (U.S.) and part 7 and appendix B of the B149 Installation Code (Canada). The minimum flue pipe diameter for conventional negative draft venting using double-wall B type vent is 4" for HD101 and HD151, 5" for HD201, HD251 and HD301, and 6" for HD401.

NOTE: Vent Adapter will have to be used to connect B vent to the unit.

The connection from the appliance vent to the stack must be as direct as possible and shall be the same diameter as, or larger than the vent outlet. The horizontal breaching of a vent must have an upward slope of not less than $1/4$ inch per linear foot from the heater to the vent terminal. The horizontal portions of the vent shall also be supported for the design and weight of the material employed to maintain clearances and to prevent physical damage or separation of joints.

Natural Draft Vertical Vent Termination

The vent terminal should be vertical and should terminate outside the building at least two (2) feet above the highest point of the roof that is within 8 feet. The vent cap should have a minimum clearance of four (4) feet horizontally from and in no case above or below (unless a four (4) foot horizontal distance is maintained) electric meters, gas meters, regulators and relief equipment. The distance of the vent terminal from adjacent public walkways, adjacent buildings, open windows and building openings must be consistent with the NFGC, or in Canada, the B149 Installation Code for Gas Burning Appliances and Equipment. Gas vents supported only by flashing and extended above the roof more than five feet should be securely guyed or braced to withstand snow and wind loads.

CAUTION: Listed vent cap terminal must be used and sized adequately to evacuate the flue products from the heaters.

Natural Draft Vertical Venting with Common Venting System, Category I Appliance Only

Manifolds that connect more than one heater to a common chimney must be sized to handle the combined load. Consult available guides for proper sizing of the manifold and the chimney. At no time should the area of the vent be less than the area of the largest heater exhaust outlet.

WARNING: Vent connectors serving appliances vented by natural draft shall not be connected into any portion of mechanical draft systems operating under a positive pressure.

CAUTION: Vent connectors for natural draft venting systems must be type "B" vent or better.

Common venting systems may be too large when an existing unit is removed. At the time of removal of an existing appliance, the following steps must be followed with each appliance remaining connected to the common venting system placed in operation, while the other appliances remaining connected to the common venting system are not in operation.

- a) Seal any unused opening in the common venting system.
- b) Visually inspect the venting system for proper size and horizontal pitch and determine there is no blockage or restriction, leakage, corrosion or other unsafe condition.
- c) Insofar as is practical, close all building doors and windows and all doors between the space in which the appliances remaining connected to the common venting system are located and other spaces of the building. Turn on clothes dryers and any appliance not connected to the common vent system. Turn on any exhaust fans, such as range hoods and bathroom exhausts, so they will operate at maximum speed. Do not operate summer exhaust fan. Close fireplace dampers.
- d) Place in operation the appliances being inspected. Follow the manufacturers instructions for lighting

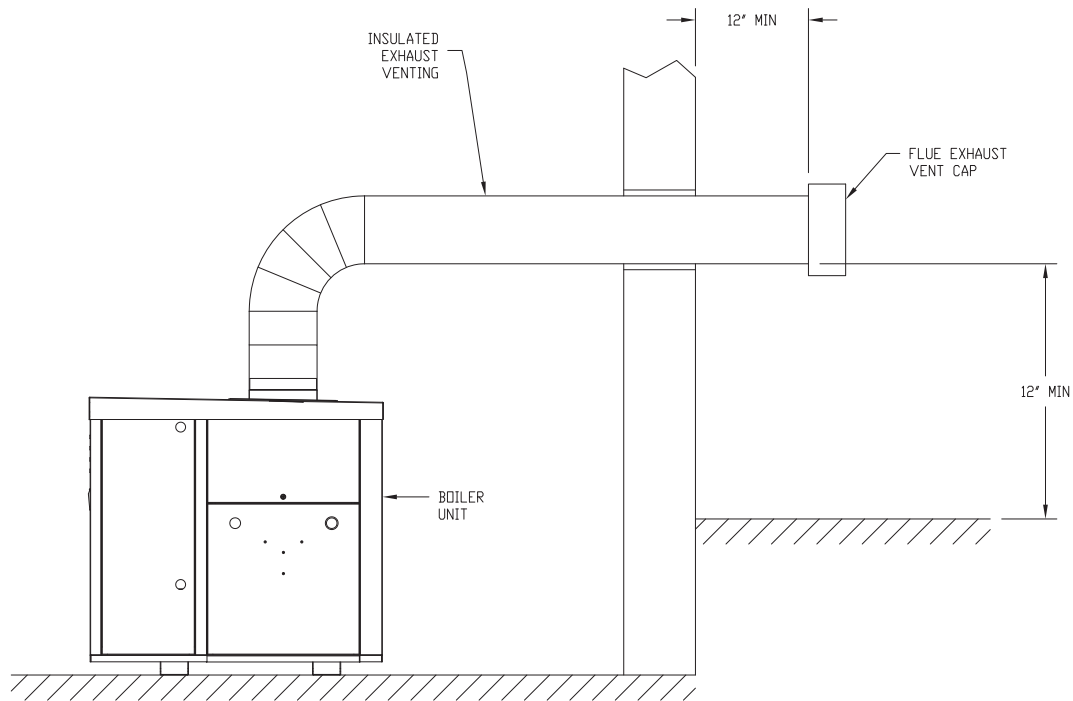

Fig. 16: Horizontal Thru-Wall Venting (Category III)

- each appliance. Adjust thermostat so appliance will operate continuously.
- e) Check the pressure at a pressure tap located 12 in. above the bottom joint of the first vertical vent pipe. Pressure should be anywhere between $-.01$ to $-.08$ in. WC.
 - f) After it has been determined that each appliance remaining connected to the common venting system properly vents when tested as outlined above, return doors, windows, exhaust fans, fireplace dampers and other gas burning appliances to their previous conditions of use.
 - g) Any improper operation of the common venting system should be corrected so that the installation conforms with the latest edition of the NFGC (US) and the B149 Installation Code (Canada). When re-sizing any portion of the common venting system, the common venting system should be re-sized to approach the minimum size as determined using the appropriate tables in Appendix G in the NFGC (US) and Appendix B of the B149 Installation Code (Canada).

Model No.	Appliance Category	Certified Venting Material	Vent Size (inches)	Max. Venting Length (feet)
HD101 HD151	III	Stainless Steel (Gas Tight)	4	100
HD201 HD251 HD301			5	
HD401			6	

Table K: Horizontal Thru-Wall Venting (Category III)

Horizontal Thru-wall Venting System (Category III) Installation

These installations utilize the heater-mounted blower to vent the combustion products to the outdoors. Combustion air is taken from the space and the vent is installed horizontally through the wall to the outdoors. Adequate combustion and ventilation air must be supplied in accordance with the NFGC or, in Canada, the B149 Installation Code.

The total length of the horizontal thru-wall exhaust vent system should not exceed one hundred (100) feet in length. If horizontal run exceeds 100 feet, an appropriately sized extractor must be used. Each elbow used is equal to ten (10) feet of straight pipe. This will allow installation in one of the four following combinations.

- 100' of straight flue pipe.
- 90' of straight flue pipe and one elbow.
- 80' of straight flue pipe and two elbows.
- 70' of straight pipe and three elbows.
- 60' of straight pipe and four elbows.

The vent cap is not considered in the overall length of the venting system. The vent must be installed to prevent the flue gas leakage. Care must be taken during assembly to ensure that all joints are sealed properly and are airtight.

The horizontal portions of the vent shall also be supported for the design and weight of the material employed to maintain clearances and to prevent physical damage or separation of joints.

The vent must be installed to prevent the potential accumulation of condensate in the vent pipes. It is recommended that:

- a) The vent be installed with a slight downward slope of not more than 1/4" per foot of horizontal run to the vent terminal.
- b) The vent be insulated through the length of the horizontal run.

For appliances installed in extreme cold climate, it is recommended that:

- a) The vent be installed with a slight upward slope of not more than 1/4" per foot of horizontal run to the vent terminal. In this case, an approved condensate trap must be installed per applicable codes.

- b) The vent be insulated through the length of the horizontal run.

Horizontal Thru-wall Direct Vent Termination

The flue exhaust direct vent cap **MUST** be mounted on the exterior of the building. The direct vent cap cannot be installed in a well or below grade. The direct vent cap must be installed at least one (1) foot above ground level and above normal snow levels.

Multiple direct vent caps **MUST NOT** be installed with one combustion air inlet directly above a direct vent cap. This vertical spacing would allow the flue products from the direct vent cap to be pulled into the combustion air intake installed above. This type of installation can cause non warrantable problems with components and poor operation of the unit due to the recirculation of flue products. Multiple direct vent caps should be installed in the same horizontal plane with a three (3) foot clearance from the side of one vent cap to the side of the adjacent vent cap(s).

Combustion air supplied from outdoors must be free of particulate and chemical contaminants. To avoid a blocked flue condition, keep the vent cap clear of snow, ice, leaves, debris, etc.

WARNING: No substitutions of flue pipe or vent cap material are allowed. Such substitutions would jeopardize the safety and health of inhabitants.

The flue exhaust direct vent cap must be furnished by the heater manufacturer in accordance with its listing. Use only the special gas vent pipes listed for use with Category III gas burning heaters, such as the stainless steel vent by Heat Fab Inc (800-772-0739), Protech Systems, Inc. (800-766-3473) or Z-Flex (800-654-5600). Pipe joints must be positively sealed. Follow the vent manufacturers installation instructions carefully.

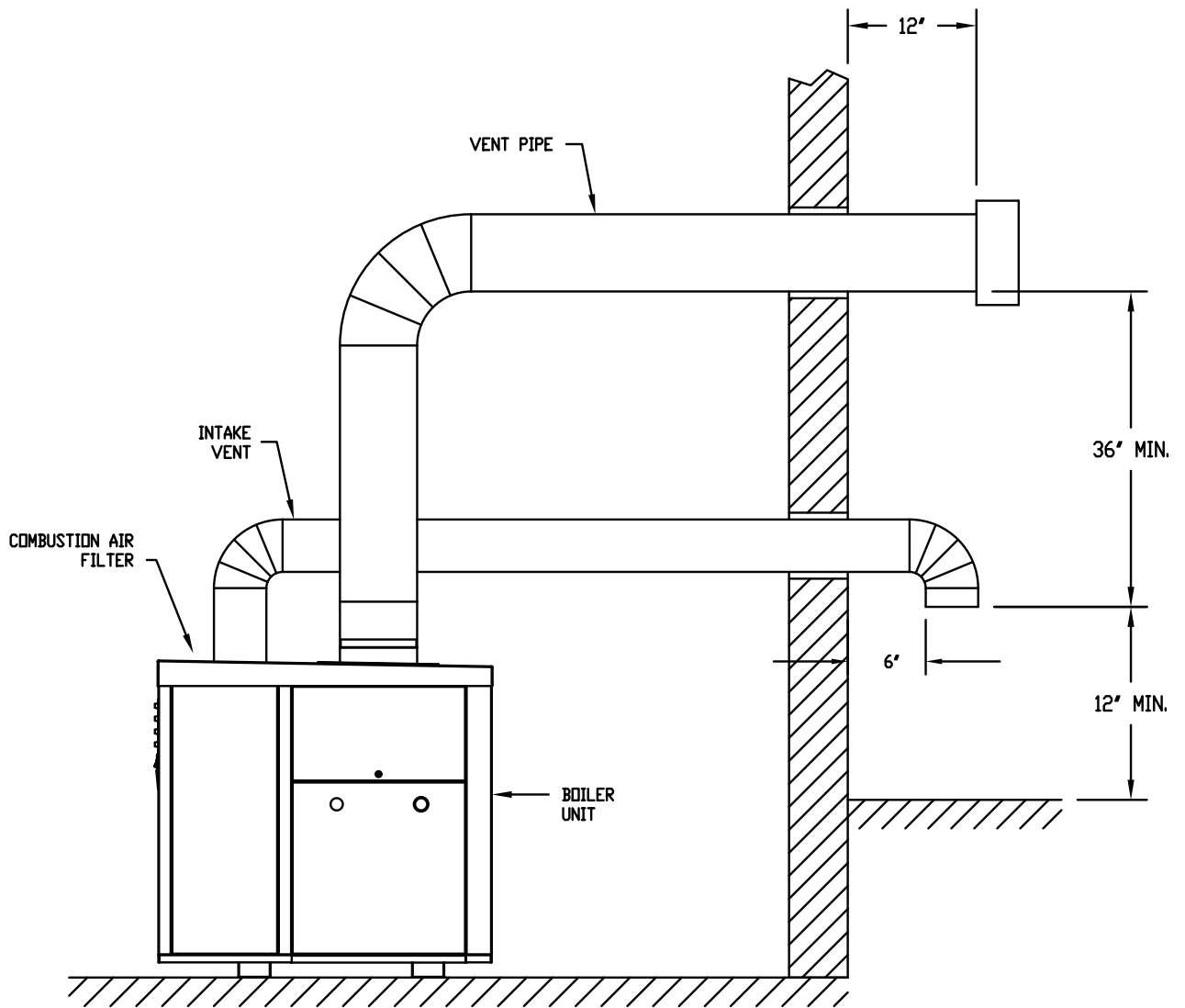

Fig. 17: Direct Vent Horizontal Thru-Wall Venting (Category III)

Model No.	Appliance Category	Certified Venting Material	Vent Size (inches)	Max. Venting Length (feet)	Combustion Air Intake Pipe Material	Air Inlet Size (inches)	Max. Air Intake Length (feet)
HD101 HD151	III	Stainless Steel (Gas Tight)	4	100, 4 Elbows Max.	Galvanized Steel PVC ABS CPVC	4	100
HD201 HD251 HD301			5				
HD401			6				

Table L: Horizontal Thru-Wall Venting

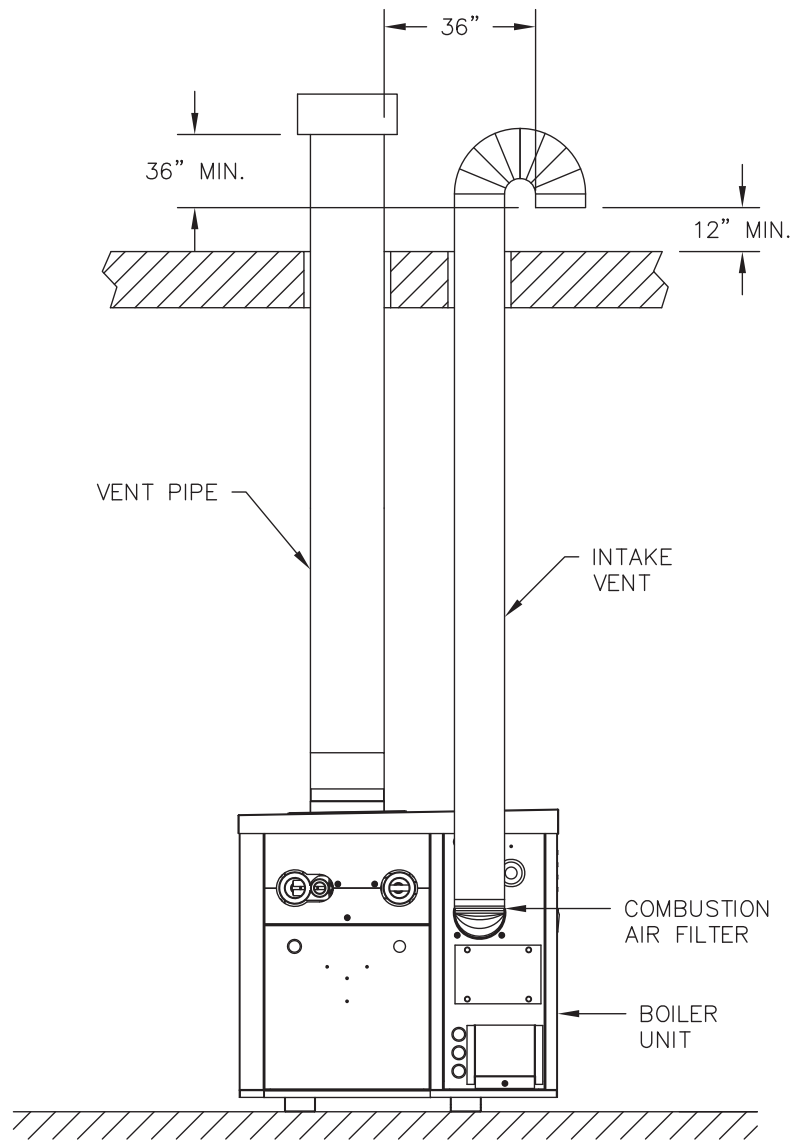

Fig. 18: Direct Vent—Vertical Venting (Category I)

Model No.	Appliance Category	Certified Venting Material	Vent Size (inches)	Min./Max. Vertical Venting Height (feet)		Combustion Air Intake Pipe Material	Air Inlet Size (inches)	Max. Air Intake Length (feet)
				Min.	Max.			
HD101 HD151	I	Type B Equivalent ¹	4	6	25*	Galvanized Steel PVC ABS CPVC	4	100
HD201 HD251 HD301			5	(HD201) 6 (HD251) 6 (HD301) 11				
HD401			6	8				

*Over 25 feet, use single acting barometric damper. Consult the factory for additional information.

¹ Vent system must be double-wall.

Table M: Vertical Venting

Vertical Direct Vent System Installation

These installations utilize the heater mounted blower to draw combustion air from outdoors and uses the natural buoyancy of the heated flue products to create a thermal driving head that expels the exhaust gases from the flue. The negative draft must be within the range of -0.01 to -0.08 in. WC as measured 12 in. from the appliance outlet to ensure proper operation. The vent material must be in accordance with the above instructions for vent materials. Vent material must be listed by a nationally recognized test agency.

The maximum and minimum venting length for Category I appliance shall be determined per the latest edition of the NFGC (U.S.) and B149 Installation Code (Canada).

The connection from the appliance exhaust vent to the stack must be as direct as possible and should be the same as or larger than the vent outlet. The vent must be installed to prevent accumulation of condensate and, where necessary, have means provided for drainage of condensate. The horizontal breaching of a vent must have an upward slope of not less than 1/4 inch per linear foot from the heater to the vent terminal. The horizontal portions of the vent shall also be supported for the design and weight of the material employed to maintain clearances and to prevent physical damage or separation of joints.

Vertical Direct Vent Termination

The exhaust vent terminal should be vertical and should terminate outside the building at least two (2) feet above the highest point of the roof within 8 feet. The vent cap should have a minimum clearance of four (4) feet horizontally from and in no case above or below (unless a four (4) foot horizontal distance is maintained) electric meters, gas meters, regulators and relief equipment. The distance of the vent terminal from adjacent public walkways, adjacent buildings, open windows and building openings must be consistent with the NFGC, or in Canada, the B149 Installation Code. Gas vents supported only by flashing and extended above the roof more than five feet should be securely guyed or braced to withstand snow and wind loads.

The vertical direct vent cap is designed for roof top mounting only. The air inlet opening **MUST** be installed one (1) foot above the roof line or above normal snow levels that might obstruct combustion air flow. This dimension is critical to the correct operation of the heater and venting system and reduces the chance of

blockage from snow. The vent cap must have a minimum 3 foot clearance from the air inlet opening.

Outdoor Installation

Outdoor models are self-venting when installed with the factory-supplied vent assembly and air intake cover and require no additional vent piping. This special vent assembly is provided with the heater in accordance with CSA requirements. It must be installed directly on the heater. See the Venting section for correct clearances.

Care must be taken when locating the outdoor unit because the flue gases discharged from the vent assembly can condense as they leave the assembly. Improper location can result in damage to adjacent structures or building finish. For maximum efficiency and safety, the following precautions must be observed:

- a) Outdoor models must be installed outdoors and must use the outdoor vent assembly and air intake cover supplied by the manufacturer.
- b) Periodically check venting system. The heater's venting areas must never be obstructed in any way and minimum clearances must be observed to prevent restriction of combustion and ventilation air. Keep area clear and free of combustible and flammable materials.
- c) Do not locate adjacent to any window, door walkway, or gravity air intake. The vent must be located a minimum of four (4) feet horizontally, or four (4) feet below, or one (1) foot above such areas.
- d) Install above grade level and above normal snow levels.
- e) Vent must be at least 3 feet above any forced air inlet located within 10 feet.
- f) Adjacent brick or masonry surfaces must be protected with a rust-resistant sheet metal plate.
- g) Multiple Outdoor Vent installations require a four (4) feet clearance between vent assemblies.

NOTE: Condensate can freeze on the vent assembly. Frozen condensate on the vent assembly can result in a blocked flue condition.

The vent assembly must be furnished by the heater manufacturer in accordance with its listing.

CONTROLS

WARNING: Installation, adjustment and service of heater controls including timing of various operating functions must be performed by a qualified installer, service agency or the gas supplier. Failure to do so may result in control damage, heater malfunction, property damage, personal injury, or death.

WARNING: Turn off the power to the heater before installation, adjustment or service of the heater controls. Failure to do so may result in heater malfunction, property damage, personal injury, or death.

CAUTION: This appliance has provisions to be connected to more than one (1) supply source. To reduce the risk of electric shock, disconnect all such connections before servicing.

CAUTION: Risk of electric shock. More than one (1) disconnect switch may be required to de-energize the equipment before servicing.

Ignition Control Module

The interrupted proved ignition device conserves energy. When additional heat is needed, the combustion air blower starts to purge all air from the combustion chamber for about 15 seconds. On proof of air flow, the air proving switch closes and the igniter is energized, eliminating the fuel costs of maintaining a constant pilot.

To ensure safe operation, the gas valve cannot open until the igniter is verified as capable of igniting the gas. The ignition module is an electronic device which closes the main gas valve within 8/10 of a second whenever the flame is interrupted. The main burner is automatically lit when the device is powered and pre-purged. The unit performs its own safety check.

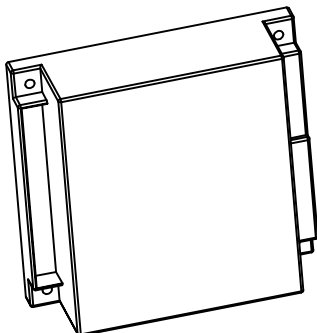

Fig. 19: Ignition Module

Digital Temperature Control

The HD401 heater can be equipped with a Raypak digital temperature control. For operation with this control, refer to the Temp-Tracker Installation and Operating Instructions, Raypak Catalog number 5000.66 (P/N 241177).

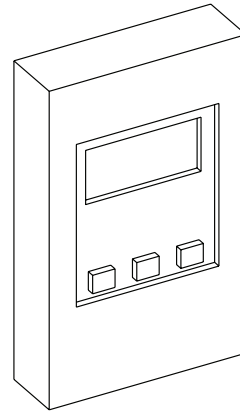

Fig. 20: Digital Temperature Control

High Limit (Manual Reset)

The heater is equipped with a manual reset high limit temperature device. If the optional adjustable limit is used, push the reset button and adjust the setting to 30°F or 40°F above desired operating temperature.

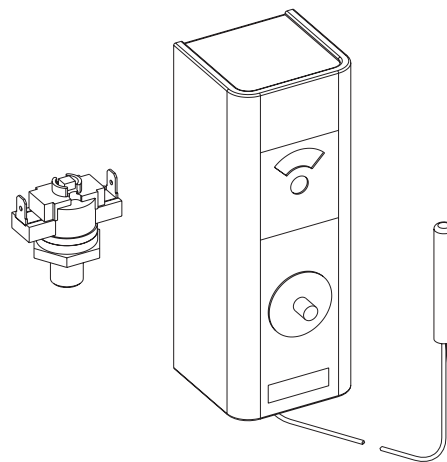

Fig. 21: Manual Reset High Limit

High Limit — Auto Reset (Optional)

This heater may be equipped with an optional adjustable auto reset high limit temperature device.

The optional adjustable auto reset high limit is located behind the front panel (see Fig. 3). Adjust the setting to approx. 20°F (10°C) above desired outlet temperature.

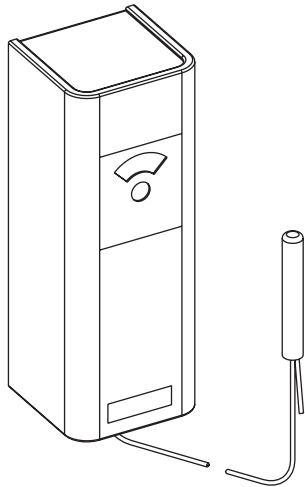

Fig. 22: High Limit — Auto Reset (Optional)

Flow Switch

Dual-purpose control shuts off heater in case of pump failure or low water flow. Mounted and wired in series with the main gas valve.

NOTE: Flow switch will not operate if flow is less than 12 gpm.

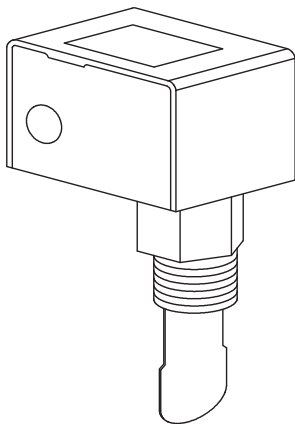

Fig. 23: Flow Switch

High and Low Gas Pressure Switches (Optional)

The low gas pressure switch (optional) connection mounts upstream of the gas valve to ensure that suffi-

cient gas pressure is present for proper regulator performance. The low gas pressure switch automatically shuts down the heater if gas supply drops below the recommended setting of 4.0 in. WC for natural gas, and 9.0 in. WC for propane gas.

The high gas pressure switch (optional) connection mounts down-stream of the gas valve. If the gas pressure regulator fails, the high gas pressure switch automatically shuts down the burner. The high gas pressure switch automatically shuts down the heater if gas manifold pressure rises above the recommended setting of 4.0 in. WC for natural gas, and 10.5 in. WC for propane gas.

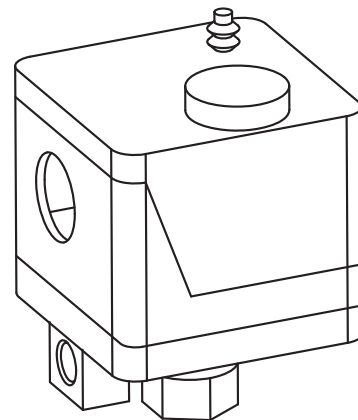

Fig. 24: Gas Pressure Switch

Low Water Cut Off (Optional)

The low water cut off automatically shuts down the burner whenever water level drops below the level of the sensing probe. A 5-second time delay prevents premature lockout due to temporary conditions such as power fluctuations or air pockets.

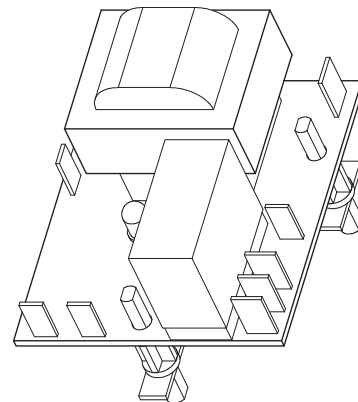
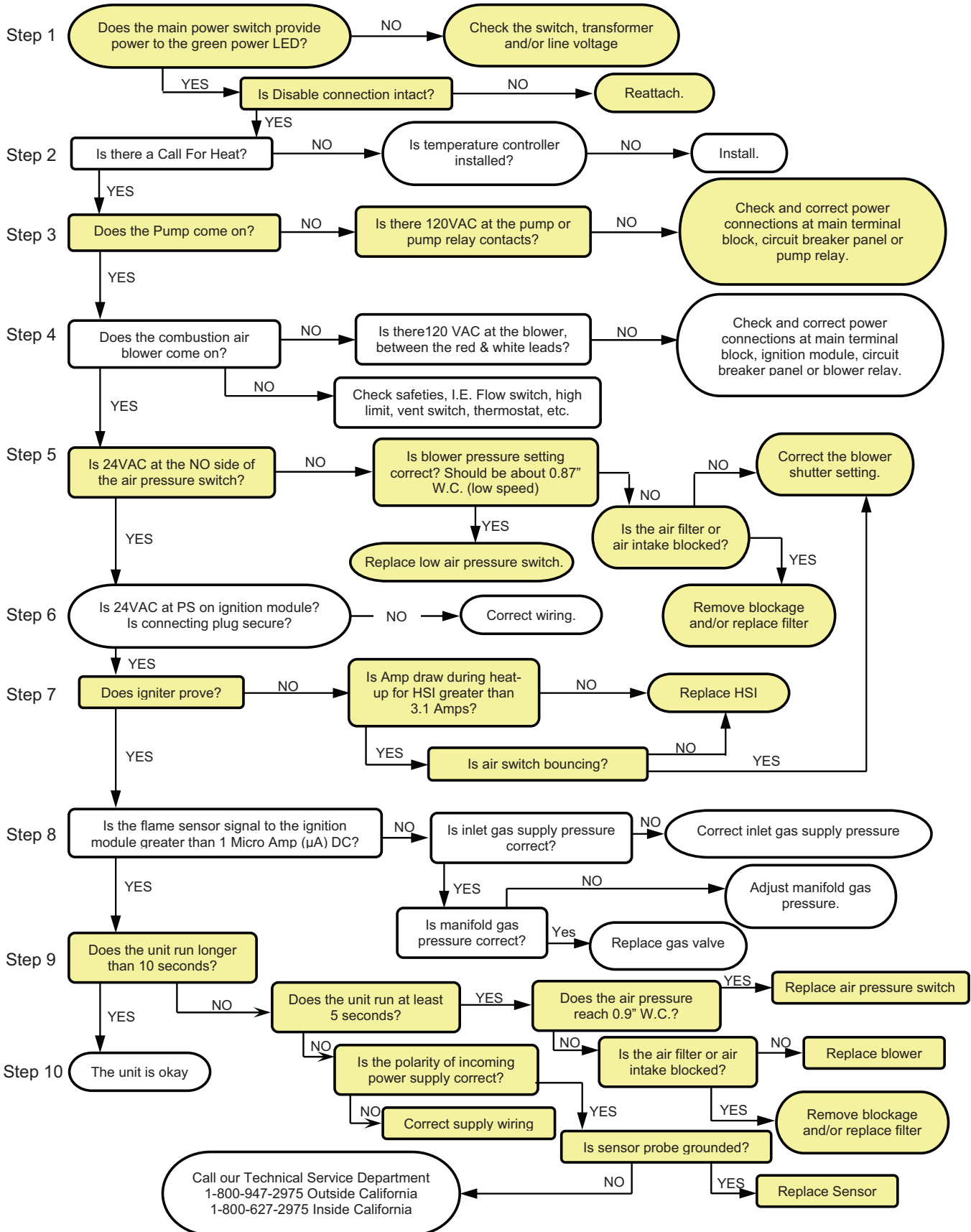

Fig. 25: Low Water Cut Off

HD101-HD401 Troubleshooting



PRE-START-UP

Domestic Hot Water Heaters

Purge all air from system before lighting heater. This can be normally be accomplished by opening a downstream valve.

Inspect Venting System:

1. Check all vent pipe connections and flue pipe material.
2. Ensure vent terminations are installed per code and are clear of all debris or blockage.

Pre-Start-Up Check

1. Verify heater is filled with water.
2. Check system piping for leaks. If found, repair immediately.
3. Vent air from system. Air in system can interfere with water circulation.
4. Purge air from gas line up to heater.

INITIAL START-UP

Tools Needed

- One 8–0–8, 16" scale manometer
- Two 6–0–6, 12" scale manometers
- 7/16" open end wrench
- 1/2" open end wrench
- Screwdriver (Standard & Phillips)
- 3/8" open end wrench
- Multi-meter
- 3/16" Allen wrench
- 3/32" Allen wrench (Honeywell or White-Rodgers gas valve)
- 5/32" Allen wrench (Invensys gas valve)
- #10 Torx driver w/center hole (Invensys gas valve)

NOTE: Digital manometers are not recommended.

Preparation for Start-Up

WARNING: Do not turn on gas at this time.

Check Power Supply

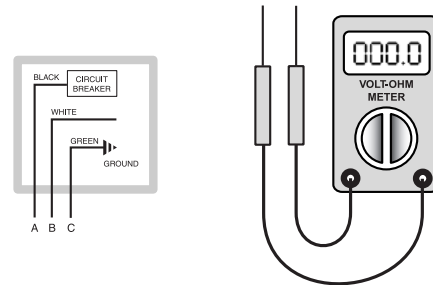

Fig. 26: Check Power Source

With volt meter at incoming power check voltage between:

- Hot - Common (~120 VAC)
- Hot - Ground (~120 VAC)
- Common - Ground (< 1 VAC)

WARNING: If Common - Ground is > 1 VAC, STOP: Contact electrician to correct ground failure. Failure to do this may burn out 120V-24V transformer, or may cause other safety control damage or failure.

Attach Manometers to Measure Pressures



- Attach 16" scale manometer to the main gas shut-off valve supply pressure tapping.
- Attach one 12" scale manometer to the manifold gas pressure tapping. (See gas valve detail on page 7.)
- Attach one 12" scale manometer to the tee near the blower housing.

FOR YOUR SAFETY READ BEFORE OPERATING

WARNING: If you do not follow these instructions exactly, a fire or explosion may result causing property damage, personal injury or loss of life.

- A. This appliance does not have a pilot. It is equipped with an ignition device which automatically lights the burner. Do not try to light the burner by hand.
- B. BEFORE OPERATING smell all around the appliance area for gas. Be sure to smell next to the floor because some gas is heavier than air and will settle on the floor.
- WHAT TO DO IF YOU SMELL GAS
- * Do not try to light any appliance.
 - * Do not touch any electric switch; do not use any phone in your building.
 - * Immediately call your gas supplier from a neighbor's phone. Follow the gas supplier's instructions.
 - * If you cannot reach your gas supplier, call the fire department.
- C. Use only your hand to push in or turn the gas control knob. Never use tools. If the knob will not push in or turn by hand, do not try to repair it, call a qualified service technician. Force or attempted repair may result in a fire or explosion.
- D. Do not use this appliance if any part has been under water. Immediately call a qualified service to inspect the appliance and to replace any part of the control system and any gas control which has been under water.

OPERATING INSTRUCTIONS

1. **STOP!** Read the safety information above on this label.
2. Set the thermostat to the lowest setting.
3. Turn off all electric power to the appliance.
4. This appliance does not have a pilot. It is equipped with an ignition device which automatically lights the burner. Do not try to light the burner by hand.
5. Remove heater door panel.
6. Turn gas control knob clockwise  to "OFF". (Or push switch to "OFF".)
7. Wait five (5) minutes to clear out any gas. Then smell for gas, including near the floor. If you smell gas STOP! Follow "B" in the safety information above on this label. If you don't smell gas, go to the next step.
8. Turn gas control knob counter clockwise  to "ON". (Or push switch to "ON".)
9. Replace heater door panel.
10. Turn on all electric power to the appliance.
11. Set thermostat to desired setting.
12. If the appliance will not operate, follow the instructions "To Turn Off Gas To Appliance" and call your service technician or gas supplier.

GAS CONTROL KNOB
SHOWN IN "ON" POSITION

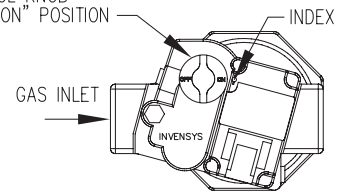

GAS CONTROL SWITCH/KNOB
SHOWN IN "ON" POSITION

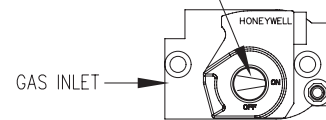

TO TURN OFF GAS TO APPLIANCE

1. Set the thermostat to the lowest setting.
2. Turn off all electrical power to the appliance if service is to be performed.
3. Remove heater door panel.
4. Turn gas control knob clockwise  to "OFF". (Or push switch to "OFF".)
5. Replace heater door panel.

Check the Gas Supply Pressure

1. Slowly turn on main gas shut-off valve.
2. Read the gas supply pressure from the manometer; minimum supply pressure is 4 in. WC, recommended supply is 7 in. WC for natural gas (minimum 11.0 in. WC for LP gas).
3. If pressure is > 14 in. WC, turn off the valve.
4. Check if the service regulator is installed and/or adjust the service regulator.

Start-Up

Blower Adjustment

1. A nylon tee fitting is connected with hoses in-line with the air pressure switches. Disconnect the plugged side and connect a manometer.
2. Close the gas valve.
3. Turn power on.
4. Incoming power at 120VAC and heater on full fire the blower pressure should be at 1.1" WC +/-0.1" WC. If this pressure is not observed on the manometer reading, adjust the air shutter on the blower to attain the correct values. (see Fig. 4, air shutter adjustment, on page 7).

5. Turn power off.
6. Reinstall rubber plug on tee.

Main Burner Adjustment

1. Turn off unit.
2. Open manual firing valve.
3. Turn on the unit, wait 15 seconds, and the igniter should glow. There's a sight glass to check igniter at both ends of the heater. Gas valve should be open after 45 seconds.
4. If burner does not light on first trial. It will retry, up to 3 times.
5. Main burner ignition – check manifold gas pressure at gas valve manifold pressure tap. (See Table N).
6. If the pressure reading differs by more than the tolerance given, adjust the gas valve accordingly. See gas valve adjustment section below for instructions.

Firing Stage	Gas Valve	Gas Type	
		Natural +/- 0.1"WC	LP/Propane +/- 0.1"WC
Full Fire	Invensys	3.4" WC	
	Honeywell	3.1" WC	9.6" WC

Table N: Gas Valve Pressures

Gas Valve Adjustment

Honeywell Gas Valve

1. While the heater is running, remove plastic cap located behind ON/OFF knob.
2. Using a small flat screwdriver, turn clockwise to increase and counterclockwise to decrease manifold pressure. See nominal gas valve manifold settings in Table N above.
3. Replace plastic cap when pressure is set.

Safety Inspection

- Replace main gas manifold adjustment screw cap.
- Check all thermostats and high limit settings.
- During the following safety checks leave manometers hooked up, check and record.
- If other gas fired equipment are in the room and on same gas main check all pressures on the Hi Delta SS with all other equipment running.
- Check thermostats for ON/OFF operation.
- Check High limits for ON/OFF operation.
- While in operation, check flow switch operation.
- Check the low gas pressure switches (For proper adjustment, if available, use the attached manometers to set pressure. The scales on the switch are approximate only); Low gas pressure switch (optional) must be set at 3.5 in. WC for natural gas and 10.5 in. WC for LP gas.
- High gas pressure switch (optional) at 1 in. WC above manifold pressure.
- Insert ignition control lockout tests as safety check.

Follow-Up

- Safety checks must be recorded as performed.
- Turn unit on.

After main burner ignition:

- Check Manometer(s) for proper reading(s).
- Cycle unit several times and recheck readings.
- Re-analyze with unit running record or print results.
- Remove all Manometers and replace hose, replace all gas pressure caps.
- Check for gas leaks one more time.

POST START-UP CHECK

Check off steps as completed:

1. Heater and heat distribution units or storage tank filled with water?
2. Automatic air vent, if used, open two full turns during venting procedure?
3. Air purged from system?
4. Air purged from gas piping? Piping checked for leaks?
5. Followed start-up procedure for proper start-up?
6. Is burner flame visible?
7. Test safety controls: If heater is equipped with a low water cut-off or additional safety controls, test for operation as outlined by manufacturer. Burner should be operating and should go off when controls are tested. When safety devices are restored, burners should reignite after pre-purge time delay.
8. Test limit control: While burner is operating, move indicator on high limit control below actual heater water temperature. Burner should go off while blower and circulator continue to operate. Raise setting on limit control above heater water temperature and burner should reignite after pre-purge time delay. NOTE: This test doesn't apply to fixed setting high limits.
9. Test ignition system safety device:
 - Turn on manual gas valve. Turn power on.
 - Set thermostat to call for heat.
 - When the unit is in operation. Disconnect combustion air blower pressure switch, burner should go off immediately.
 - Wait 5 minutes.
 - Reconnect combustion air pressure switch, burner should reignite after pre-purge time delay.
10. To restart system, follow lighting instructions in the Operation section.
11. High limit control set to design temperature requirements of system? For multiple zones: flow adjusted as required in each zone?

12. Heater cycled with thermostat? Raise to highest setting and verify heater goes through normal start-up cycle. Reduce to lowest setting and verify heater goes off.
13. Observed several operating cycles for proper operation?
14. Set room thermostat or tankstat to desired temperature?
15. Reviewed all instructions shipped with this heater with owner or maintenance person, returned to envelope and given to owner?

Air Filter Inspection/Removal

1. Turn power off.
2. Locate the Air Filter panel below the air intake duct.

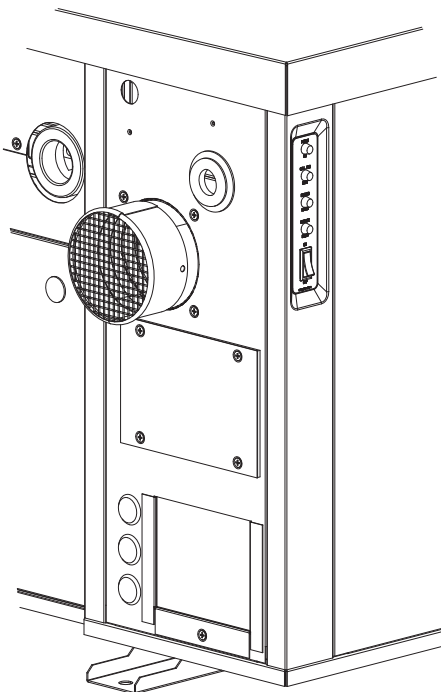

Fig. 28: Locate the Air Filter Panel

3. Remove the (4) screws holding the panel in place.

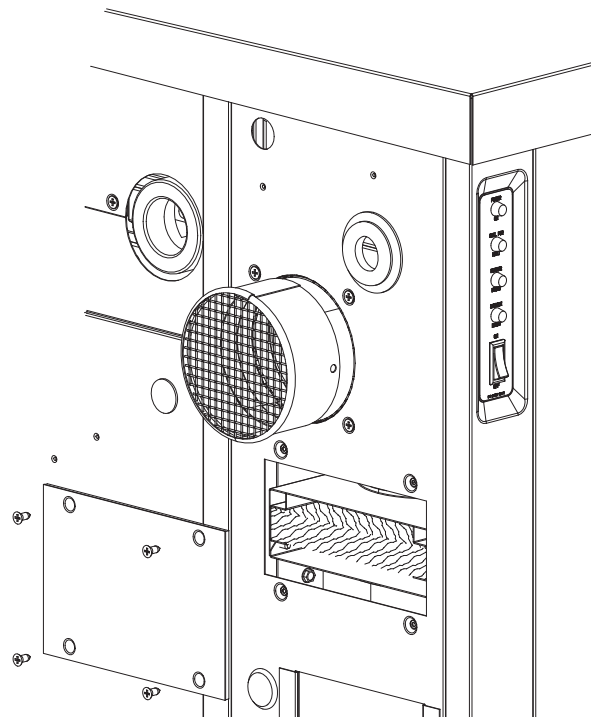

Fig. 29: Remove the Screws and Panel

4. Pull the air filter out for inspection. Replace if necessary.

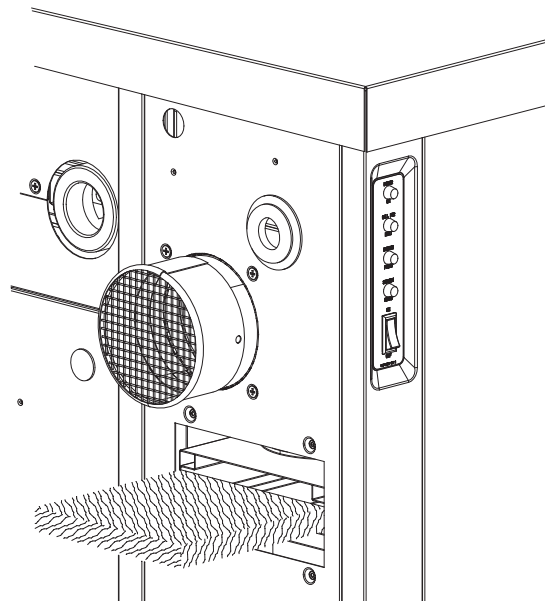

Fig. 30: Inspect the Air Filter

5. When replacing, note the direction of the air flow defined on the side of the filter. The arrow should be pointing downward.
6. Replace the panel and screws before operating.

Heat Exchanger Removal

Refer to Fig. 31 for the following procedure.

1. Before beginning, make sure the heater is cool to the touch. Shut water, gas and electricity off, close valves and relieve pressure, then remove the relief valve. Remove side inspection panels.
2. Remove screw behind inspection panels holding the jacket top down.
3. Remove the front panel. Remove two additional screws holding the jacket top to the top support.
4. Disconnect vent pipe from the flue exhaust and set aside.
5. Remove jacket top, then disconnect vent switch hose.
6. Remove two rows of screws holding the flue collector to the combustion chamber. Remove two additional screws located on the front combustion panel. Cut any silicone holding the flue collector and heat exchanger in place.
7. Carefully lift and remove the flue collector.
8. Lift heat exchanger straight up being careful not to damage the refractory.
9. Reverse the above procedure to re-install. Make sure sufficient high temperature silicone sealant (RTV) is placed along the vertical sides of the tube sheet and flue collector.

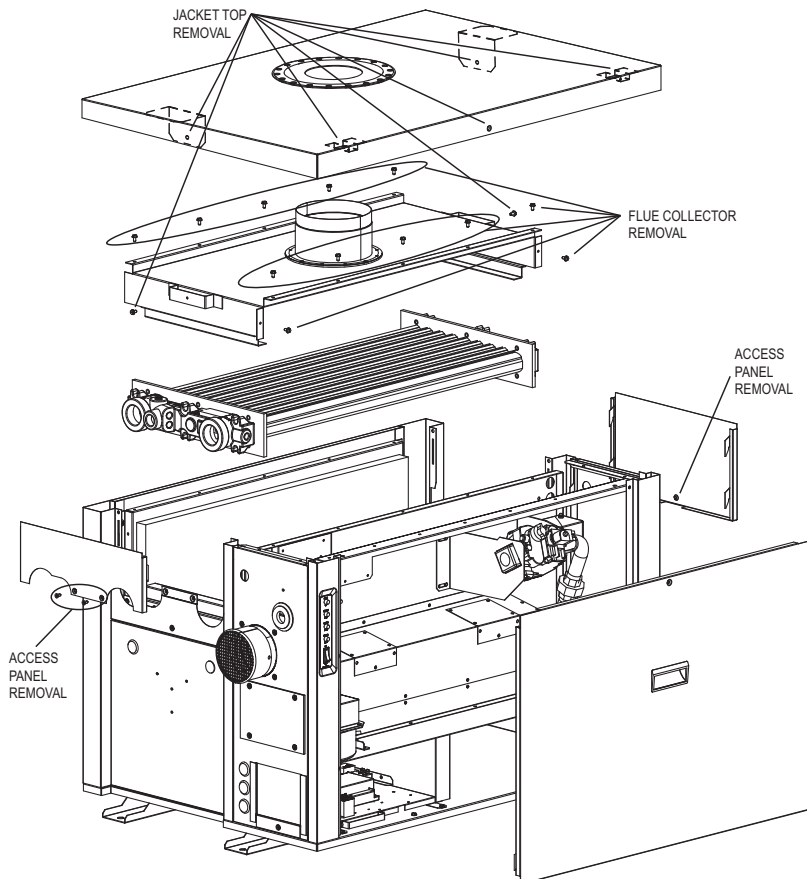

Fig. 31: Heat Exchanger Removal

MAINTENANCE

Suggested Minimum Maintenance Schedule:

Regular service by a qualified service agency and maintenance must be performed to ensure maximum heater operating efficiency. Maintenance as outlined below may be performed by the owner.

Yearly (Beginning of each heating season):

1. Annual service call by qualified service agency.
2. Visually check top of vent for soot. Call service person to clean. Some sediment at bottom of vent is normal.
3. Visually inspect venting system for proper function, deterioration or leakage.
4. Check that heater area is free from combustible materials, gasoline, and other flammable vapors and liquids.
5. Check for and remove any obstruction to the flow of combustion or ventilation air to heater.
6. Follow pre-start-up check in the Initial Start-up section.
7. Visually inspect burner flame. Should see light blue flame. Visually inspect hot surface igniter for damage, cracking or debris build-up.
8. Check operation of safety devices. Refer to manufacturer's instructions.
9. Follow oil-lubricating instructions on circulator (if required). Over-oiling will damage circulator. Water-lubricated circulators do not need oiling.
10. To avoid potential of severe burn, DO NOT REST HANDS ON OR GRASP PIPES. Use a light touch - return piping will heat up quickly.
11. Check blower and blower motor. Clean and oil as necessary.

12. Check for piping leaks around circulators, relief valves and other fittings. Repair, if found. DO NOT use petroleum based stop leak.
13. Check air filter and replace if necessary.

Daily:

1. Check that heater area is free from combustible materials, gasoline, and other flammable vapors and liquids.
2. Check for and remove any obstruction to the flow of combustion or ventilation air to heater.

Monthly:

1. Check for piping leaks around circulators, mixing valves, relief valves, and other fittings. If found, repair at once. DO NOT use petroleum-based stop leak compounds.
2. Visually inspect burner flame.
3. Visually inspect venting system for proper function, deterioration or leakage.
4. Check air vents for leakage.

Quarterly:

1. Check relief valve. Refer to manufacturer's instructions on valve.
2. Test low water cut-off, if used. Refer to manufacturer's instructions.
3. Check the air filter; replace if necessary.

APPENDIX

Inside Combustion Air Contamination:

All heaters experience some condensation during start-up. The condensate from flue gas is slightly acidic. In most cases the pH level is not harmful to vents or drains. When combustion air is contaminated by vapors from products in areas listed below, the acidic levels in the condensate increase. Higher acidic levels attack many materials, including stainless steel commonly used in high efficiency systems.

The heater can use special corrosion-resistant non-metallic intake vent material. You may, however, choose to use outside combustion air for one or more of these reasons:

- installation is in an area containing contaminants listed below which will induce acidic condensation.
- you want to reduce infiltration into your building through openings around windows and doors.
- you are using AL29-4C stainless steel vent pipe, which is more corrosion-resistant than standard metallic vent pipe. In extremely contaminated areas, this may also experience deterioration.

Products causing contaminated combustion air:

- spray cans containing chloro/fluorocarbons
- permanent wave solutions
- chlorinated waxes/cleaners
- chlorine-based swimming pool chemicals
- calcium chloride used for thawing
- sodium chloride used for water softening
- refrigerant leaks
- paint or varnish removers
- hydrochloric acid/muriatic acid
- cements and glues
- antistatic fabric softeners used in clothes dryers
- chloride-type bleaches, detergents, and cleaning solvents found in household laundry rooms
- adhesives used to fasten building products
- ... and other similar products.

Areas causing contaminated combustion air:

- dry cleaning/laundry areas and establishments
- metal fabrication plants
- beauty shops
- refrigeration repair shops
- photo processing plants
- auto body shops
- plastic manufacturing plants
- furniture refinishing areas and establishments
- new building construction
- remodeling areas.

Check for areas and products as listed above before installing heater. If found:

- remove products permanently, OR
- provide outdoor combustion air.

Important Instructions for the Commonwealth of Massachusetts

The Commonwealth of Massachusetts requires compliance with regulation 248 CMR 4.00 and 5.00 for installation of through – the – wall vented gas appliances as follows:

(a) For all side wall horizontally vented gas fueled equipment installed in every dwelling, building or structure used in whole or in part for residential purposes, including those owned or operated by the Commonwealth and where the side wall exhaust vent termination is less than seven (7) feet above finished grade in the area of the venting, including but not limited to decks and porches, the following requirements shall be satisfied:

1. INSTALLATION OF CARBON MONOXIDE DETECTORS. At the time of installation of the side wall horizontal vented gas fueled equipment, the installing plumber or gasfitter shall observe that a hard wired carbon monoxide detector with an alarm and battery back-up is installed on the floor level where the gas equipment is to be installed. In addition, the installing plumber or gasfitter shall observe that a battery operated or hard wired carbon monoxide detector with an alarm is installed on each additional level of the dwelling, building or structure served by the side wall horizontal vented gas fueled equipment. It shall be the responsibility of the property owner to secure the services of qualified licensed professionals for the installation of hard wired carbon monoxide detectors

a. In the event that the side wall horizontally vented gas fueled equipment is installed in a crawl space or an attic, the hard wired carbon monoxide detector with alarm and battery back-up may be installed on the next adjacent floor level.

b. In the event that the requirements of this subdivision can not be met at the time of completion of installation, the owner shall have a period of thirty (30) days to comply with the above requirements; provided, however, that during said thirty (30) day period, a battery operated carbon monoxide detector with an alarm shall be installed.

2. APPROVED CARBON MONOXIDE DETECTORS. Each carbon monoxide detector as required in accordance with the above provisions shall comply with NFPA 720 and be ANSI/UL 2034 listed and IAS certified.

3. SIGNAGE. A metal or plastic identification plate shall be permanently mounted to the exterior of the building at a minimum height of eight (8) feet above grade directly in line with the exhaust vent terminal for the horizontally vented gas fueled heating appliance or equipment. The sign shall read, in print size no less than one-half (1/2) inch in size, "GAS VENT DIRECTLY BELOW. KEEP CLEAR OF ALL OBSTRUCTIONS".

4. INSPECTION. The state or local gas inspector of the side wall horizontally vented gas fueled equipment shall not approve the installation unless, upon inspection, the inspector observes carbon monoxide detectors and signage installed in accordance with the provisions of 248 CMR 5.08(2)(a)1 through 4.

(b) **EXEMPTIONS:** The following equipment is exempt from 248 CMR 5.08(2)(a)1 through 4:

1. The equipment listed in Chapter 10 entitled "Equipment Not Required To Be Vented" in the most current edition of NFPA 54 as adopted by the Board; and

2. Product Approved side wall horizontally vented gas fueled equipment installed in a room or structure separate from the dwelling, building or structure used in whole or in part for residential purposes.

(c) **MANUFACTURER REQUIREMENTS - GAS EQUIPMENT VENTING SYSTEM PROVIDED.** When the manufacturer of Product Approved side wall horizontally vented gas equipment provides a venting system design or venting system components with the equipment, the instructions provided by the manufacturer for installation of the equipment and the venting system shall include:

1. Detailed instructions for the installation of the venting system design or the venting system components; and

2. A complete parts list for the venting system design or venting system.

(d) **MANUFACTURER REQUIREMENTS - GAS EQUIPMENT VENTING SYSTEM NOT PROVIDED.** When the manufacturer of a Product Approved side wall horizontally vented gas fueled equipment does not provide the parts for venting the flue gases, but identifies "special venting systems", the following requirements shall be satisfied by the manufacturer:

1. The referenced "special venting system" instructions shall be included with the appliance or equipment installation instructions; and

2. The "special venting systems" shall be Product Approved by the Board, and the instructions for that system shall include a parts list and detailed installation instructions.

(e) A copy of all installation instructions for all Product Approved side wall horizontally vented gas fueled equipment, all venting instructions, all parts lists for venting instructions, and/or all venting design instructions shall remain with the appliance or equipment at the completion of the installation.

GAS PRESSURE SUPERVISION

The Commonwealth of Massachusetts requires listed high and low gas pressure switches (manual reset) for any model with a maximum firing input greater than 1,000,000 Btu/Hr in accordance with 248 CMR 7.04(11)(d).

A gas pressure regulator (field supplied) is required in the gas train ahead of the heater, for heaters having input rates greater than 1,000,000 Btu/Hr, in accordance with 248 CMR 7.04 Figure 3B requirements.



www.raypak.com

Raypak, Inc., 2151 Eastman Avenue, Oxnard, CA 93030 (805) 278-5300 Fax (805) 278-5468
Litho in U.S.A.