

INSTALLATION & OPERATING INSTRUCTIONS

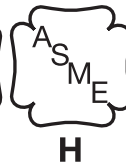

**Models 1005–2005
Types H, WH, WHP & P**



WARNING: Improper installation, adjustment, alteration, service or maintenance can cause property damage, personal injury, exposure to hazardous materials* or loss of life. Review the information in this manual carefully. *This unit contains materials that have been identified as carcinogenic, or possibly carcinogenic, to humans.

FOR YOUR SAFETY: Do not store or use gasoline or other flammable vapors and liquids or other combustible materials in the vicinity of this or any other appliance. To do so may result in an explosion or fire.

WHAT TO DO IF YOU SMELL GAS:

- Do not try to light any appliance.
- Do not touch any electrical switch; do not use any phone in your building.
- Immediately call your gas supplier from a neighbor's phone. Follow the gas supplier's instructions.
- If you cannot reach your gas supplier, call the fire department.

Installation and service must be performed by a qualified installer, service agency or the gas supplier.

This manual should be maintained in legible condition and kept adjacent to the heater or in a safe place for future reference.

Raypak®
A Rheem® Company

Rev. 5 reflects the following:

Changes to: “Stainless steel condensing heat exchanger” was “secondary heat exchanger” throughout, Warnings on page 4, Ratings & Certifications on page 5, Direct Vent information on page 12, Relief Valve information on page 14, Fig. 17 and Pool Heating instructions on page 17, Electrical Power Connections on page 20, Combustion CO2 levels on pages 20 and 47, Fig. 19 on page 21, Venting instructions on page 22, Table L on page 23, Table M on page 25, Fig. 24 on page 26, Warning on page 26, Termination instructions on page 28, Mode 8 instructions on page 34, Table P on page 35, wiring diagrams on pages 43 and 44, Table W on page 47, igniter resistance values on page 53

Additions: CSA LLC mark on front cover, Warning on page 17, Warning on page 22, Note on page 29, Centrotherm Polypropylene Venting Option instructions on page 31, Fig. 31 on page 32, Table S on page 36, Variable Speed Injector Pump information and Figs. 43-44 on page 40

Deletions: Note regarding salt water on page 19, PVC Vent Adapter illustration on page 31, Adapter Thimble and Vent Termination illustrations on page 32

CONTENTS

WARNINGS		
Pay Attention to These Terms	4	29
BEFORE INSTALLATION		
Product Receipt	4	30
Model Identification	5	
Ratings and Certifications	5	31
Installations at Elevation	5	32
Component Locations	5	38
General Information	5	
Time/Temperature Relationships in Scalds	5	
GENERAL SAFETY		
INSTALLATION		
Installation Codes	6	43
Equipment Base	6	44
Clearances	6	45
Combustion and Ventilation Air	7	45
Conventional Combustion Air Supply	7	45
Water Piping	7	46
Hydronic Heating	8	46
Domestic Hot Water	8	46
Combined Potable Water and Space Heating	8	50
Pool Heating	9	50
Gas Supply	9	50
Electrical Power Connections	13	50
Field Wiring Connection	13	50
Venting	14	51
Venting Installation Tips	15	52
Venting Configurations	16	52
Outdoor Installation	17	52
PVC Venting Option (D-32)	17	52
Centrotherm Polypropylene Venting Option (D-33)	17	52
Controls	19	53
Heater Sequence of Operation	20	54
WIRING DIAGRAMS		
Models 1005 & 1505	22	54
Model 2005	22	54
START-UP		
Pre Start-up	24	55
Pre Start-up Check	24	55
Initial Start-up	24	55
Preparation	24	55
Start-Up	24	55
OPERATION		
Lighting Instructions	24	55
To Turn Off Gas To Appliance	24	55
TROUBLESHOOTING		
UDB Fault History	24	55
MAINTENANCE		
Suggested Minimum	24	55
Maintenance Schedule	24	55
Preventive Maintenance	24	55
Schedule	24	55
APPENDIX		
Inside Air Contamination	24	55
Important Instructions for the Commonwealth of Massachusetts	24	55
WARRANTIES		
		56

WARNINGS

Pay Attention to These Terms

DANGER:	Indicates the presence of immediate hazards which will cause severe personal injury, death or substantial property damage if ignored.
WARNING:	Indicates the presence of hazards or unsafe practices which could cause severe personal injury, death or substantial property damage if ignored.
CAUTION:	Indicates the presence of hazards or unsafe practices which could cause minor personal injury or product or property damage if ignored.
NOTE:	Indicates special instructions on installation, operation, or maintenance which are important but not related to personal injury hazards.

DANGER: Make sure the gas on which the heater will operate is the same type as that specified on the heater rating plate.

WARNING: Heaters using propane gas are different from natural gas models. A natural gas heater will not function safely on propane and vice versa. Conversions of heater gas type should only be made by qualified installers using factory supplied components. The heater should only use the fuel type in accordance with listing on rating plate. Any other fuel usage will result in death or serious personal injury from fire and/or explosion.

WARNING: Should overheating occur or the gas supply valve fail to shut, do not turn off or disconnect the electrical supply to the heater. Instead, shut off the gas supply at a location external to the heater.

WARNING: Do not use this heater if any part has been under water. Immediately call a qualified service technician to inspect the heater and to replace any part of the control system and any gas control which has been under water.

WARNING: To minimize the possibility of improper operation, serious personal injury, fire, or damage to the heater:

- Always keep the area around the heater free of combustible materials, gasoline, and other flammable liquids and vapors.
- Heater should never be covered or have any blockage to the flow of fresh air to the heater.

WARNING: Risk of electrical shock. More than one disconnect switch may be required to de-energize the equipment before servicing.

WARNING - CALIFORNIA PROPOSITION 65: This product contains chemicals known to the State of California to cause cancer, birth defects or other reproductive harm.

WARNING: Both natural gas and propane have an odorant added to aid in detecting a gas leak. Some people may not physically be able to smell or recognize this odorant. If you are unsure or unfamiliar with the smell of natural gas or propane, ask your local gas supplier. Other conditions, such as "odorant fade," which causes the odorant to diminish in intensity, can also hide, camouflage, or otherwise make detecting a gas leak by smell more difficult.

WARNING: UL recognized fuel gas detectors are recommended in all enclosed propane and natural gas applications wherein there is a potential for an explosive mixture of fuel gas to accumulate and their installation should be in accordance with the detector manufacturer's recommendations and/or local laws, rules, regulations, or customs.

CAUTION: If this heater is to be installed above radiation level, it must be provided with a low water cut-off device at the time of heater installation.

CAUTION: This heater requires forced water circulation when the burner is operating. Severe damage will occur if the heater is operated without proper water flow circulation.

CAUTION: If this heater is to be installed in a negative or positive pressure equipment room, there are special installation requirements. Consult factory for details.

BEFORE INSTALLATION

Raypak strongly recommends that this manual be reviewed thoroughly before installing your XTherm heater. Please review the General Safety information before installing the heater. Factory warranty does not apply to heaters that have been improperly installed or operated. (Refer to the warranty at the back of this manual.) Installation and service must be performed by a qualified installer, service agency or gas supplier. If, after reviewing this manual, you still have questions which this manual does not answer, please contact your local Raypak representative or visit our website at www.raypak.com.

Thank you for purchasing a Raypak product. We hope you will be satisfied with the high quality and durability of our equipment.

Product Receipt

On receipt of your heater it is suggested that you visually check for external damage to the shipping crate. If the crate is damaged, make a note to that effect on the Bill of Lading when signing for the shipment. Next, remove the heater from the shipping packaging. Report any damage to the carrier immediately.

On occasion, items are shipped loose. Be sure that you receive the correct number of packages as indicated on the Bill of Lading.

Claims for shortages and damages must be filed with the carrier by consignee. Permission to return goods must be received from the factory prior to shipping. Goods returned to the factory without an authorized Returned Goods Receipt number will not be accepted. All returned goods are subject to a restocking charge.

When ordering parts, you must specify the model and serial number of the heater. When ordering under warranty conditions, you must also specify the date of installation.

Purchased parts are subject to replacement only under the manufacturer's warranty. Debits for defective replacement parts will not be accepted. Parts will be replaced in kind only per Raypak's standard warranties.

Model Identification

The model identification number and heater serial number are found on the heater rating plate located on

the upper rear jacket panel of the heater. The model number will have the form H7-2005 or similar depending on the heater size and configuration. The letter(s) in the first group of characters identifies the application (H = Hydronic Heating, WH = Domestic Hot Water (DHW), WHP = Water Heater for Pool Heating). The number which follows identifies the firing mode (7 = electronic modulation, 1 = On/Off). The second group of characters identifies the size of the heater (four numbers representing the approximate MBTUH input), and, where applicable, a letter, indicating the manufacturing series.

Ratings and Certifications

Standards:

- ANSI Z21.13 · CSA 4.9 - latest edition, Gas-Fired Hot Water Boilers
- CAN 3.1 - latest edition, Industrial and Commercial Gas-Fired Package Boilers
- ANSI Z21.56 · CSA 4.7 - latest edition, Gas-Fired Pool Heaters
- ANSI Z21.10.3 · CSA 4.3 - latest edition, Gas Water Heaters
- SCAQMD Rule 1146.2
- ANSI Z21.56 · CSA 4.7 - latest edition, Pool Heaters

All Raypak heaters are National Board Approved, and design-certified and tested by the Canadian Standards Association (CSA) for the U.S. and Canada. Each primary heat exchanger is constructed in accordance with Section IV, and each stainless steel condensing heat exchanger in accordance with Section VIII, of the American Society of Mechanical Engineers (ASME) Heater Pressure Vessel Code and bears the applicable ASME stamp. This heater also complies with the latest edition of the ASHRAE 90.1 Standard.

WARNING: Altering any Raypak pressure vessel by installing replacement heat exchangers, tube bundle headers, or any ASME parts not manufactured and/or approved by Raypak will instantly void the ASME and CSA ratings of the vessel and any Raypak warranty on the vessel. Altering the ASME or CSA ratings of the vessel also violates national, state, and local approval codes.

Installations at Elevation

Rated inputs are suitable for up to 4,500 ft elevation without de-rating. Consult your local representative or the factory for installations at altitudes over 4,500 ft above sea level. No hardware changes are required to the heaters for installations up to 10,000 ft (adjustments may be required).

Component Locations

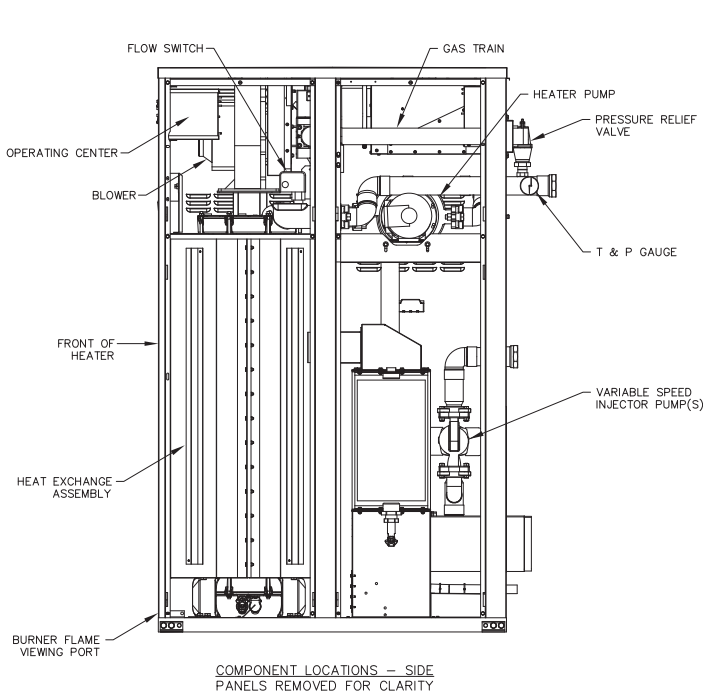

Fig. 1: Component Locations – Right Side

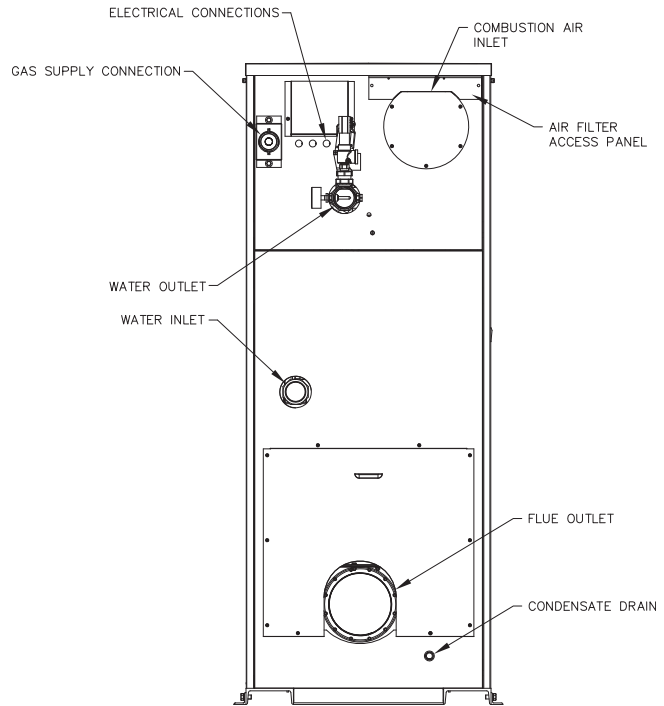

Fig. 3: Component Locations – Rear

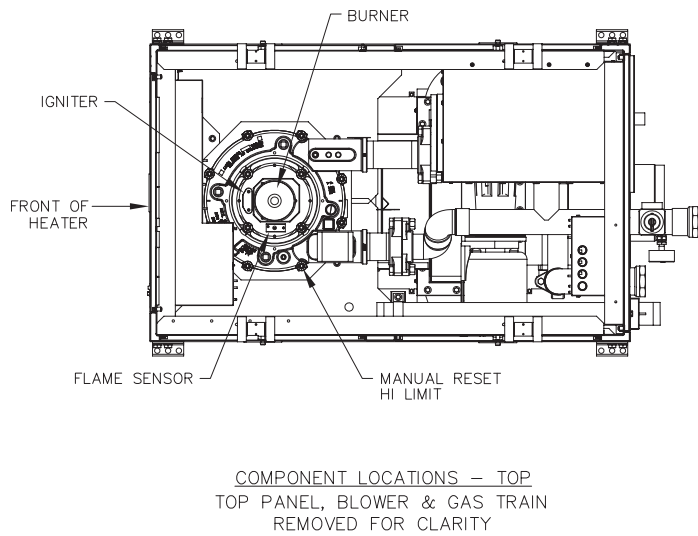

Fig. 2: Component Locations – Top

General Information

Model No.	MBTUH Input		Water Conn. (NPT)	Gas Conn. (NPT)		Vent Size (in.)	
	Max.	Min.		N	P	Flue	Intake
1005	999	250	2-1/2	1-1/4	1	6	6
1505	1500	375	2-1/2	1-1/4	1	8	8
2005	1999	500	2-1/2	2	1	8	8

Table A: Basic Data

GENERAL SAFETY

To meet commercial hot water use needs, the high limit safety control on this water heater will shut off the main gas valve before the outlet temperature reaches 210°F. However, water temperatures over 125°F can cause instant severe burns or death from scalds. When supplying general purpose hot water, the recommended initial setting for the temperature control is 125°F.

Safety and energy conservation are factors to be considered when setting the water temperature on the thermostat. The most energy-efficient operation will result when the temperature setting is the lowest that satisfies the needs of the application.

Water temperature over 125°F can cause instant severe burns or death from scalds. Children, disabled and elderly are at highest risk of being scalded.

- Feel water before bathing or showering.
- Temperature limiting valves are available.

NOTE: When this water heater is supplying general purpose hot water for use by individuals, a thermostatically controlled mixing valve for reducing point of use water temperature is recommended to reduce the risk of scald injury. Contact a licensed plumber or the local plumbing authority for further information.

Maximum water temperatures occur just after the heater's burner has shut off. To determine the water temperature being delivered, turn on a hot water faucet and place a thermometer in the hot water stream and read the thermometer.

This section applies to Hot Water Supply Boilers and Hot Water Heaters ONLY. For sanitary rinse applications where outlet temperatures of 180°F to 195°F are required, a boiler is recommended since the 200°F limit on water heaters will NOT allow the heater to maintain these desired sanitary rinse temperatures.

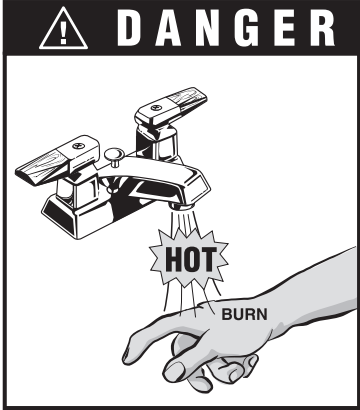
DANGER

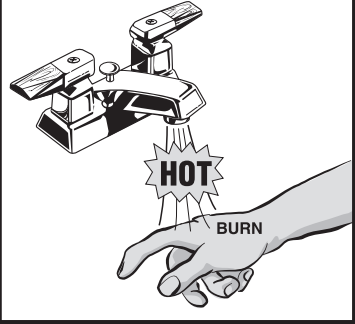

Water temperature over 125°F can cause instant severe burns or death from scalds.

Children, disabled, and elderly are at highest risk of being scalded.

See instruction manual before setting temperature at water heater.

Feel water before bathing or showering.

Temperature limiting valves are available, see manual.

Time/Temperature Relationships in Scalds

The following chart details the relationship of water temperature and time with regard to scald injury and may be used as a guide in determining the safest water temperature for your applications.

Water Temp.	Time to Produce Serious Burn
120°F	More than 5 minutes
125°F	1-1/2 to 2 minutes
130°F	About 30 seconds
135°F	About 10 seconds
140°F	Less than 5 seconds
145°F	Less than 3 seconds
150°F	About 1-1/2 seconds
155°F	About 1 second

Table courtesy of The Shriners Burn Institute

Table B: Time to Produce Serious Burn

The temperature of the water in the heater can be regulated by using the Raypak Modulating Temperature Control. To comply with safety regulations, the control is set at 120°F when shipped from the factory (Mode 3 default setting for Tank Target).

To adjust the water temperature, follow the instruction for the operation of the control starting on page 33 of this manual. The control is shown below for identification purposes only. (See Fig. 4.)

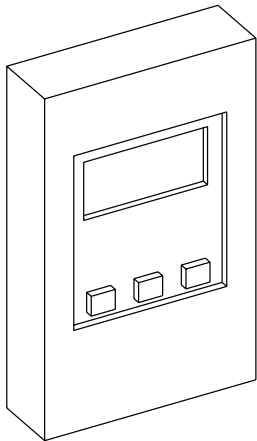

Fig. 4: Modulating Temperature Control

CAUTION: Hotter water increases the risk of scalding! There is a hot water scald potential if the thermostat is set too high.

INSTALLATION

Installation Codes

Installations must follow these codes:

- Local, state, provincial, and national codes, laws, regulations and ordinances
- National Fuel Gas Code, ANSI Z223.1/NFPA 54 – latest edition (NFGC)
- National Electrical Code, ANSI/NFPA 70 - latest edition (NEC)
- Standard for Controls and Safety Devices for Automatically Fired Boilers, ANSI/ASME CSD-1, (CSD-1) when required
- For Canada only: CAN/CSA B149 Natural Gas and Propane Installation Code and CSA C22.1 C.E.C. Part 1 (C22.1)

Equipment Base

The heater should be mounted on a level, structurally sound surface. The heater is approved for installation on a combustible surface but must NEVER be installed on carpeting. Gas-fueled equipment installed in enclosed parking garages must be located at least 18 in. above the floor.

CAUTION: This heater should be located in an area where water leakage will not result in damage to the area adjacent to the appliances or to the structure. When such locations cannot be avoided, it is recommended that a suitable catch pan, adequately drained, be installed under the appliance. The pan must not restrict air flow.

In addition, the heater shall be installed such that the gas ignition system components are protected from water (dripping, spraying, rain, etc.) during appliance operation or service (circulator replacement, control replacement, etc.).

If the heater needs to be secured to the ground, use the brackets that were used to bolt the heater to the shipping pallet.

Clearances

Indoor Installations

Heater Side	Minimum Clearance from Combustible Surfaces	Minimum Service Clearance
Floor*	0"	0"
Rear	12"	36"
Right Side	1"	24"
Left Side	1"	1"
Top	0"	10"
Front	Open	24"
Vent	1"	1"

*DO NOT install on carpeting.

Table C: Clearances – Indoor Installations

For ease of servicing, provide a minimum clearance of at least 24 in. on the right side, 24 in. in front, at least 36 in. on the rear and 10 in. above the top of the heater. This will allow the heater to be serviced in its installed location without movement or removal of the heater.

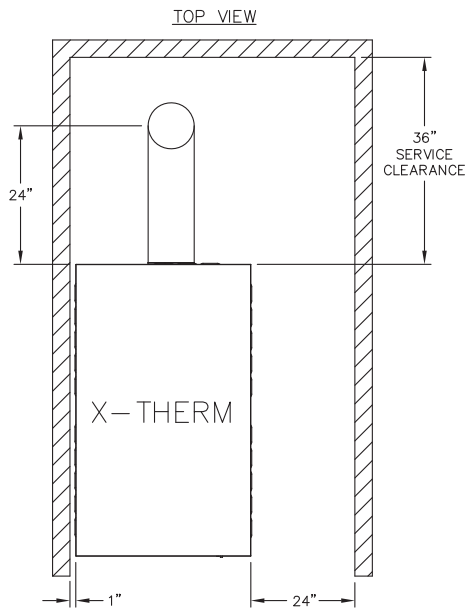

REAR EXHAUST INSTALLATION

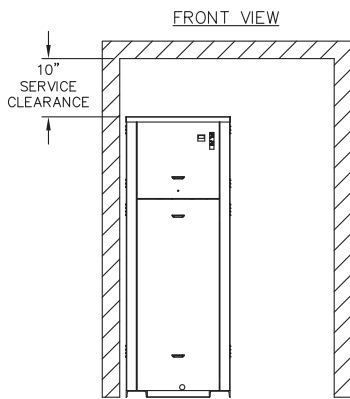

VERTICAL CLEARANCE
(ALL INSTALLATIONS)

Venting not shown for clarity. Heater must be vented per instructions in this manual

Fig. 5: Minimum Clearances from Combustible Surfaces – Indoor and Outdoor Installations

Service clearances less than the minimum may require removal of the heater to service either the heat exchanger or the burner components. In either case, the heater must be installed in a manner that will enable the heater to be serviced without removing any structure around the heater.

Outdoor Installations

These heaters are design-certified for outdoor installation. Heaters must not be installed under an overhang unless they are in accordance with local installation codes and the requirements of the gas supplier. Three sides must be open in the area under the overhang.

Roof water drainage must be diverted away from heaters installed under overhangs.

Heater Side	Min. Clearance from Combustible Surfaces	Minimum Service Clearance
Rear	12"	36"
Right Side	1"	24"
Left Side	1"	1"
Top	Unobstructed	10"
Vent Termination	12"	12"

Table D: Clearances – Outdoor Installations

Combustion and Ventilation Air

NOTE: Use of this heater in construction areas where fine particulate matter, such as concrete or dry-wall dust, is present may result in damage to the heater that is not covered by the warranty. If operated in a construction environment, a clean source of combustion air must be provided directly to the heater.

Indoor Units

This heater must be supplied with sufficient quantities of non-contaminated air to support proper combustion and equipment ventilation. Combustion air can be supplied via conventional means where combustion air is drawn from the area immediately surrounding the heater, or via direct vent, where combustion air is drawn directly from outside. All installations must comply with the requirements of the NFGC (U.S.) and B149 (Canada), and all local codes.

CAUTION: Combustion air must not be contaminated by corrosive chemical fumes which can damage the heater and void the warranty. (See the Appendix.)

NOTE: It is recommended that the intake vent be insulated to minimize sweating.

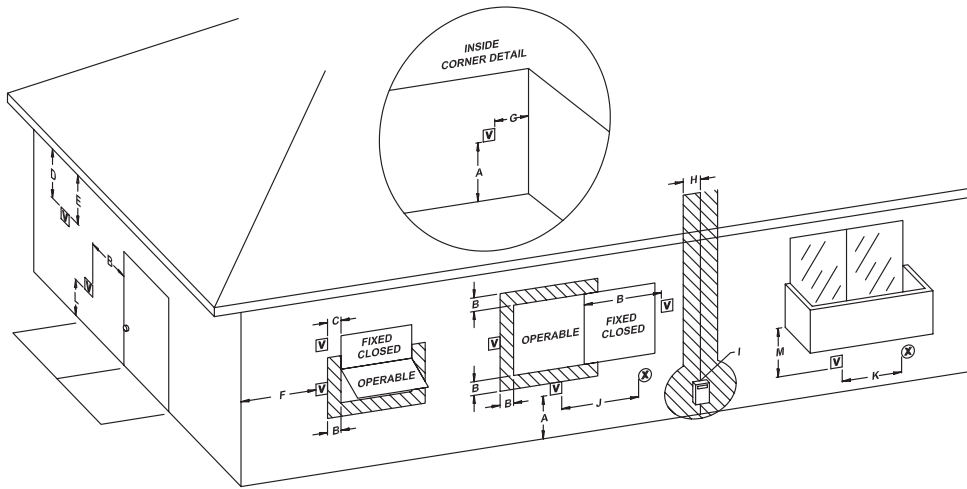

Fig. 6: Minimum Clearances from Vent/Air Inlet Terminations – Indoor and Outdoor Installations

		U.S. Installations¹	Canadian Installations²
A	Clearance above grade, veranda, porch, deck, or balcony	1 ft (30 cm)	1 ft (30 cm)
B	Clearance to window or door that may be opened	4 ft (1.2m) below or to side of opening; 1 foot (30 cm) above opening	3 ft (91 cm)
C	Clearance to permanently closed window	*	*
D	Vertical clearance to ventilated soffit located above the terminal within a horizontal distance of 2 ft (61cm) from the centerline of the terminal	5 ft (1.5m)	*
E	Clearance to unventilated soffit	*	*
F	Clearance to outside corner	*	*
G	Clearance to inside corner	6 ft (1.83m)	*
H	Clearance to each side of center line extended above meter/regulator assembly	*	3 ft (91 cm) within a height 15 ft above the meter/regulator assembly
I	Clearance to service regulator vent outlet	*	6 ft (1.83m)
J	Clearance to non-mechanical air supply inlet to building or the combustion air inlet to any other appliance	4 ft (1.2m) below or to side of opening; 1 ft (30 cm) above opening	3 ft (91 cm)
K	Clearance to mechanical air supply inlet	3 ft (91 cm) above if within 10 ft (3m) horizontally	6 ft (1.83m)
L	Clearance above paved sidewalk or paved driveway located on public property	7 ft (2.13m)	7 ft (2.13m) t
M	Clearance under veranda, porch, deck or balcony	*	12 in. (30 cm) TT

¹ In accordance with the current ANSI Z223.1/NFPA 54 National Fuel Gas Code

² In accordance with the current CAN/CSA-B149 Installation Codes

t Vent terminal shall not terminate directly above sidewalk or paved driveway located between 2 single family dwellings that serves both dwellings

TT Permitted only if veranda, porch, deck, or balcony is fully open on a minimum of two sides beneath the floor and top of terminal and underside of veranda, porch, deck or balcony is greater than 1 ft (30cm)

* Clearances in accordance with local installation codes and the requirements of the gas supplier

Table E: Vent/Air Inlet Termination Clearances

Combustion Air Filter

This heater is supplied with an integral combustion air filter. This filter will reduce the amount of particulates passed through the combustion system and heat exchanger but will not protect against chemical inside air contamination (See Appendix). The filter must be checked periodically to verify that adequate combustion air is being supplied to the heater. See the Maintenance section of this manual for information on checking the filter and establishing service intervals.

Direct Vent

If outside air is drawn through the intake pipe directly to the unit for combustion:

1. Convert the unit to draw air through an air intake duct at the rear of the cabinet. As shipped, XTherm heaters draw combustion air from inside the cabinet.
2. Turn off all power to the heater.
3. Ensure that the heater is cool to the touch before proceeding with the installation.
4. Remove both the left and right rear side access panels.

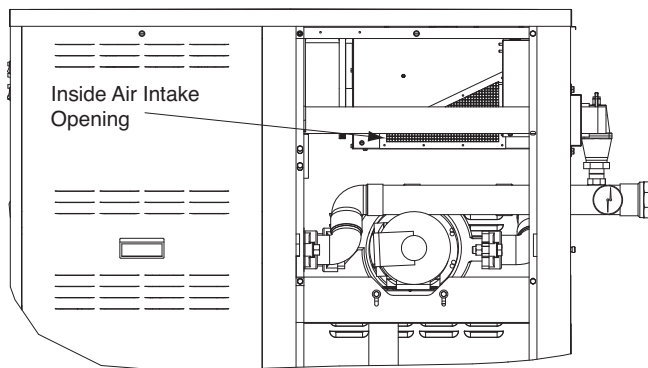

Fig. 7: Remove the Rear-side Access Panels

5. From the right-rear side access area, install the inside air intake cover panel using the nine hex-head screws provided (see Fig. 8).

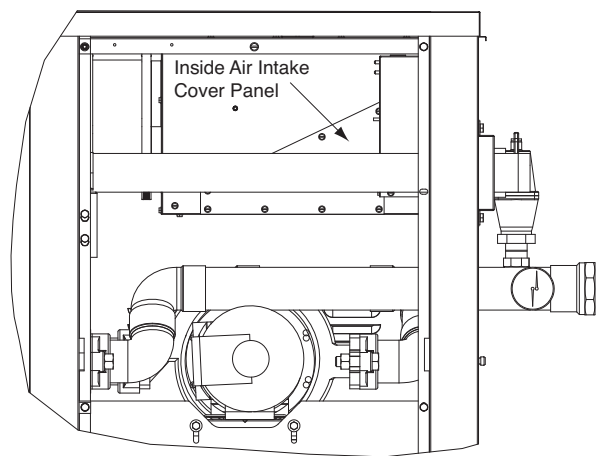

Fig. 8: Install the Inside Air Intake Cover Panel

6. Optional—For applications where condensation may form on cold intake air ducting, install the condensate drip pan to the bottom of the air filter box using the four screws provided (make sure the pan is angled slightly downward toward the rear of the heater as shown in Fig. 9).

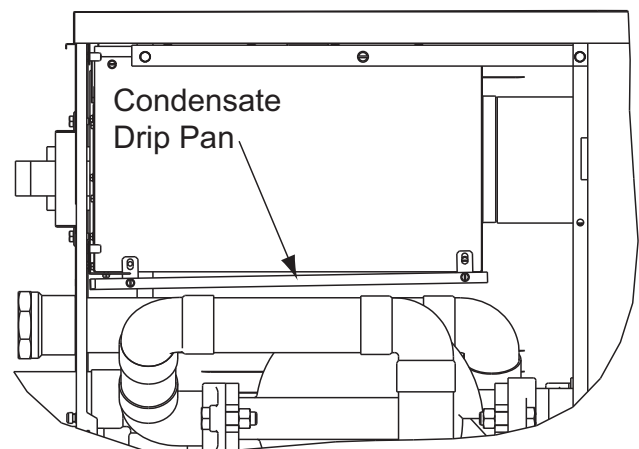

Fig. 9: Install the Condensate Drip Pan

7. Remove the air intake cover panel by removing the 5 phillips head screws holding it in place.

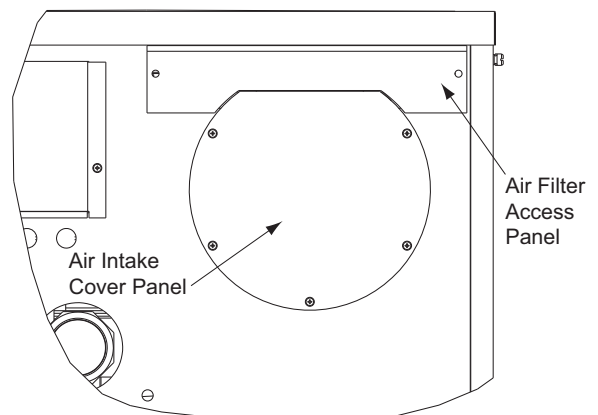

Fig. 10: Remove the Air Intake Cover

- Remove the debris screen (or cover panel for model 1005) by removing the six screws holding it in place.

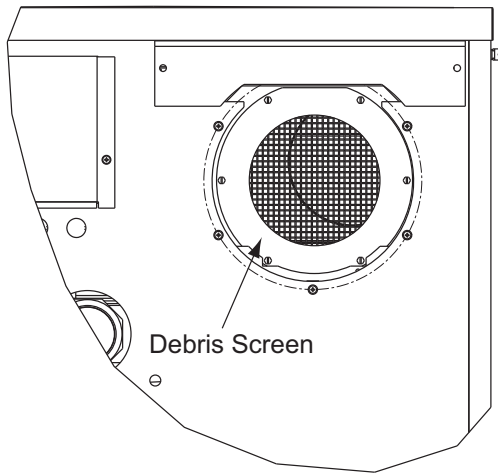

Fig. 11: Remove the Debris Screen

- Install the intake air collar using the six screws removed in step 8 above.

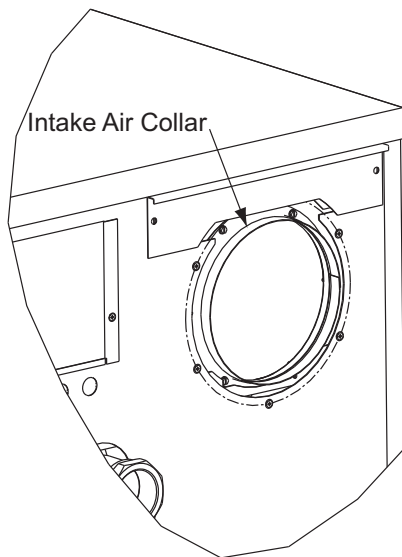

Fig. 12: Install the Intake Air Collar

- Replace all the access panels.

NOTE: Make sure that the air intake piping is installed in a manner that allows full access to the air filter without damage to the filter.

- Install combustion air direct vent in accordance with Fig. 27 (horizontal) or Fig. 28 (vertical) of this manual (pages 27 and 28, respectively).

- Ventilation of the space occupied by the heater(s) is recommended and can be provided by an opening(s) for ventilation air at the highest practical point communicating with the outdoors. The total cross-sectional areas should be at least 1 in.² of free area per 20,000 BTUH (111 mm² per kW) of total input rating of all equipment in the room, when the opening is communicating directly with the outdoors or through vertical duct(s). The total cross-sectional area should be at least 1 in.² of free area per 10,000 BTUH (222 mm² per kW) of total input rating of all equipment in the room, when the opening is communicating with the outdoors through horizontal duct(s). Damage to the equipment due to inadequate ventilation of the space is not a warrantable failure.

- In cold climates, and to mitigate potential freeze-up, Raypak highly recommends the installation of a motorized sealed damper to prevent the circulation of cold air through the heater during the non-operating hours.

TruSeal™ Combustion Air

In addition to the 13 previous steps, combustion air may be ducted directly to the heater by using PVC, CPVC or sealed single-wall galvanized ducting. The duct will attach directly to the field installed air collar located on the rear of the heater, using three or four sheet metal screws (not supplied) equally positioned around the circumference of the duct. The screws and duct connection point should be sealed with RTV (not supplied). TruSeal is generally used when damaging contaminants are present in the mechanical room. All ducting must be self-supported.

CAUTION: Use TruSeal combustion air if damaging airborne contaminants are or may be present in the heater area. See the Appendix of this manual regarding air contamination.

Conventional Combustion Air Supply

U.S. Installations

All Air from Inside the Building

The confined space shall be provided with **TWO** permanent openings communicating directly with an additional room(s) of sufficient volume so that the combined volume of all spaces meets the criteria for a room large in comparison (NFGC). The total input of all gas utilization equipment installed in the combined space shall be considered in making this determination. **Each opening** shall have a minimum free area of 1 in.² per 1,000 BTUH (2,225 mm² per kW) of the total input rating of all gas utilization equipment in the confined space, but not less than 100 in.² (645 cm²). One opening shall commence within 12 in. (305 mm) of the top, and one opening shall commence within 12 in. (305 mm) of the bottom of the enclosure. The minimum dimension of air openings shall be not less than 3 in. (76 mm) in any direction.

All Air from Outdoors

The confined space shall communicate with the outdoors in accordance with one of the methods below. The minimum dimension of air openings shall not be less than 3 in. (76 mm) in any direction. Where ducts are used, they shall be of the same cross-sectional area as the net free area of the openings to which they connect.

1. **Two permanent openings**, one commencing within 12 in. (305 mm) of the top, and one commencing within 12 in. (305 mm) of the bottom of the enclosure, shall be provided. The openings shall communicate directly, or by ducts, with the outdoors or spaces (crawl or attic) that freely communicate with the outdoors.
 - a. Where directly communicating with the outdoors or where communicating to the outdoors through vertical ducts, **each opening** shall have a minimum free area of 1 in.² per 4,000 BTUH (550 mm² per kW) of total input rating of all equipment in the enclosure.
 - b. Where communicating with the outdoors through horizontal ducts, each opening shall have a minimum free area of 1 in.² per 2,000 BTUH (1,100 mm² per kW) of total input rating of all equipment in the enclosure.

2. **One permanent opening**, commencing within 12 in. (305 mm) of the top of the enclosure, shall be permitted where the equipment has clearances of at least 1 in. (25 mm) from the sides and back and 6 in. (152 mm) from the front of the appliance. The opening shall directly communicate with the outdoors or shall communicate through a vertical or horizontal duct to the outdoors or spaces that freely communicate with the outdoors, and shall have a minimum free area of:
 - a. 1 in.² per 3,000 BTUH (740 mm² per kW) of the total input rating of all equipment located in the enclosure, and
 - b. Not less than the sum of the areas of all vent connectors in the confined space.

WARNING: Do not use the “one permanent opening” method if the equipment room is under negative pressure conditions.

Canadian Installations

CAUTION: All combustion air must be drawn from the air outside of the building; the mechanical equipment room must communicate directly with the outdoors.

1. Ventilation of the space occupied by the heater shall be provided by an opening(s) for ventilation air at the highest practical point communicating with the outdoors. The total cross-sectional area of such an opening(s) shall be at least 10% of the area required in 2. and 3. (below), but in no case shall the cross-sectional area be less than 10 in.² (65 cm²).
2. For heaters using a barometric damper in the vent system there shall be a permanent air supply opening(s) having a cross section area of not less than 1 in.² per 7,000 BTUH (320 mm² per kW) up to and including 1 million BTUH, plus 1 in.² per 14,000 BTUH (160 mm² per kW) in excess of 1 million BTUH. This opening(s) shall be either located at or ducted to a point not more than 18 in. (450 mm) nor less than 6 in. (152 mm) above the floor level. The duct can also “goose neck” through the roof. The duct is preferred to be straight down and terminated 18 in. (450 mm) from the floor, but not near piping. This air supply opening requirement shall be in addition to the air opening for ventilation air required in 1. (above).

WARNING: Care must be taken to ensure that the equipment room is not under negative pressure conditions.

3. For heaters not using a barometric damper in the vent system, and when air supply is provided by natural air flow from outdoors for a power burner and there is no draft regulator, draft hood or similar flue gas dilution device installed in the same space, in addition to the opening for ventilation air required in 1., there shall be a permanent air supply opening(s) having a total cross-sectional area of not less than 1 in.² for each 30,000 BTUH (74 mm² per kW) of total rated input of the burner(s), and the location of the opening(s) shall not interfere with the intended purpose of the opening(s) for ventilation air referred to in 1. This opening(s) can be ducted to a point not more than 18 in. (450 mm) nor less than 6 in. (152 mm) above the floor level. The duct can also “goose neck” through the roof. The duct is preferred to be straight down 18 in. (450 mm) from the floor, but not near piping.
4. Refer to the B149 Installation Code for additional information.

Water Piping

General

The heater should be located so that any water leaks will not cause damage to the adjacent area or structures.

CAUTION: This heater must be installed with a Primary-Secondary piping arrangement for the integral pumping system to function properly.

NOTE: Minimum pipe size for the heater inlet/outlet connections is dependent on the equivalent length of piping between the load loop and the heater loop, the operating conditions and the size of the heater. See Table G on page 16.

Relief Valve Installation and Piping

WARNING: Pressure relief valve discharge piping must be piped near the floor and close to a drain to eliminate the potential of severe burns. Do not pipe to any area where freezing could occur. Refer to local codes.

The heater is supplied with a Section IV “HV” stamped relief valve sized for the full input of the unit. The relief valve is mounted directly to the heater outlet. Relief valve discharge piping shall provide no less than the cross sectional area of the relief valve outlet and must be routed to a safe point of discharge. Installation must comply with all national, state and local codes.

Temperature & Pressure Gauge

The temperature and pressure gauge is factory-installed at the boiler outlet.

Hydrostatic Test

Unlike many types of heaters, this heater does not require hydrostatic testing prior to being placed in operation. The heat exchanger has already been factory-tested and is rated for 160 psi operating pressure. However, Raypak does recommend hydrostatic testing of the piping connections to the heater and the rest of the system prior to operation. This is particularly true for hydronic systems using expensive glycol-based anti-freeze. Raypak recommends conducting the hydrostatic test before connecting gas piping or electrical supply.

Leaks must be repaired at once to prevent damage to the heater. NEVER use petroleum-based stop-leak compounds.

To perform hydrostatic test:

1. Connect fill water supply. With bleed valve open, fill heater with water. When water flows from bleed valve, shut off water. Close bleed valve. Carefully fill the rest of the system, making sure to eliminate any entrapped air by using high-point vents. Close feed valve. Test at standard operating pressure for at least 24 hours.
2. Make sure constant gauge pressure has been maintained throughout test.
3. Check for leaks. Repair if found.

Raypak Integral Cold Water Protection

CAUTION: Damage due to internal condensation may occur if the heater inlet water temperature does not exceed 50°F (22°C) within 7 minutes of start-up.

XTherm heaters are equipped with an integral cold water protection system. Units equipped with the dual injector pump system are designed to operate with heater inlet water temperatures down to 50°F continuous. Under start up conditions the dual injector system can operate with fluid temperatures down to 32°F. Operation at lower temperatures will create unwarrantable damage to the injector pumps. XTherm WH and WHP models equipped with single injector pumps are designed for typical domestic hot water and commercial pool heating operating conditions respectively. Contact your local representative or the factory for applications assistance.

Hydronic Heating

Pump Selection

The heater is equipped with an integral cold water protection system that includes dual modulating injector pumps to pull the required flow from the system loop and a heater pump, sized by the factory, for the optimal ΔT across the primary heat exchanger. The system is designed for continuous return temperatures from 50°F to 180°F.

Feedwater Regulator

Raypak recommends that a feedwater regulator be installed and set at 12 psi minimum pressure at the highest point of the system. Install a check valve or back flow device upstream of the regulator, with a manual shut-off valve as required by local codes.

Piping

All high points should be vented. A heater installed above radiation level must be provided with a low water cut-off device (sales order option F-10). This heater, when used in connection with a refrigeration system, must be installed so that the chilled medium is piped in parallel with the heater with appropriate valves to prevent the chilled medium from entering the heater.

The piping system of a hot water heater connected to heating coils located in air handling units where they may be exposed to circulating refrigerated air, must be equipped with flow control valves or other automatic means to prevent gravity circulation of the heater water during the cooling cycle. It is highly recommended that the piping be insulated.

Air-Separation/Expansion Tank

All heaters should be equipped with a properly sized expansion tank and air separator fitting as shown in Fig. 13.

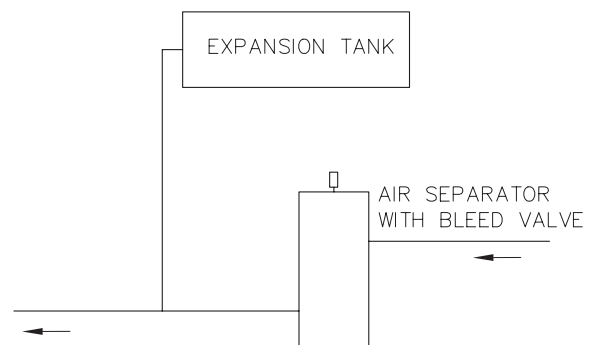

Fig. 13: Air-Separation/Expansion Tank

Three-Way Valves

WARNING: Three-way valves intended to regulate system water temperatures by reducing flow in the boiler should not be used.

XTherm heaters have an integral cold water protection system to maintain required temperatures and flow rates.

System Return Temp (°F)	Model 1005			Model 1505			Model 2005		
	Supply Temp ¹ (°F)	Minimum Pipe Size ²		Supply Temp ¹ (°F)	Minimum Pipe Size ²		Supply Temp ¹ (°F)	Minimum Pipe Size ²	
		<80' equiv.	80-200' equiv.		<80' equiv.	80-200' equiv.		<80' equiv.	80-200' equiv.
60	138	2"NPT	2 1/2"NPT	147	2"NPT	2 1/2"NPT	154	2"NPT	2 1/2"NPT
80	138	2"NPT	2 1/2"NPT	147	2"NPT	2 1/2"NPT	154	2 1/2"NPT	3"NPT
100	138	2 1/2"NPT	3"NPT	147	2 1/2"NPT	3"NPT	154	2 1/2"NPT	3"NPT
120	145	2 1/2"NPT	3"NPT	158	2 1/2"NPT	3"NPT	170	2 1/2"NPT	3"NPT
140	165	2 1/2"NPT	3"NPT	178	2 1/2"NPT	3"NPT	190	2 1/2"NPT	3"NPT
160	185	2 1/2"NPT	3"NPT	198	2 1/2"NPT	3"NPT	210	2 1/2"NPT	3"NPT

¹-Approximate high fire heater outlet temperature based on the standard heater pump and the recommended connecting pipe size.

²-Minimum pipe size based on total equivalent feet of supply and return piping between the system loop and heater.

Table F: Boiler Temperatures and Minimum Pipe Size at Varying Return Temperatures

Fitting Type	Equivalent Length (ft)	
	2-1/2" NPT	3" NPT
90° Elbow (Std.)	8.5	9.4
90° Elbow (Long rad.)	3.5	3.6
45° Elbow	3.0	3.4
Gate Valve (Full open)	1.6	1.6
Swing Check Valve	22	25

Note: Equivalent lengths are calculated based on typical operating conditions with typical Schedule 40 pipe fittings and valves. Equivalent lengths are approximate and may vary greatly.

Table G: Equivalent Lengths of Pipe for Typical Fittings

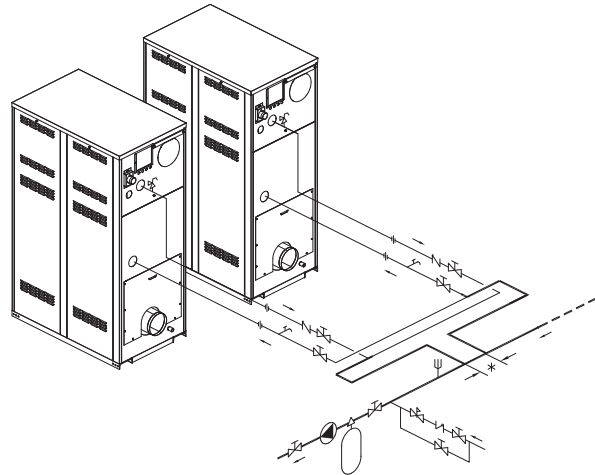

*Maximum 4 times the pipe diameter or 12", whichever is less.

Fig. 15: Dual Heaters (Reverse/Return) with Primary/Secondary Piping

Domestic Hot Water

When designing the hot water piping system for domestic hot water applications, water hardness should be considered. See Table H on page 18 for the required tubing sizes and expected supply temperatures for different operating conditions. Water hardness is expressed in grains per gallon.

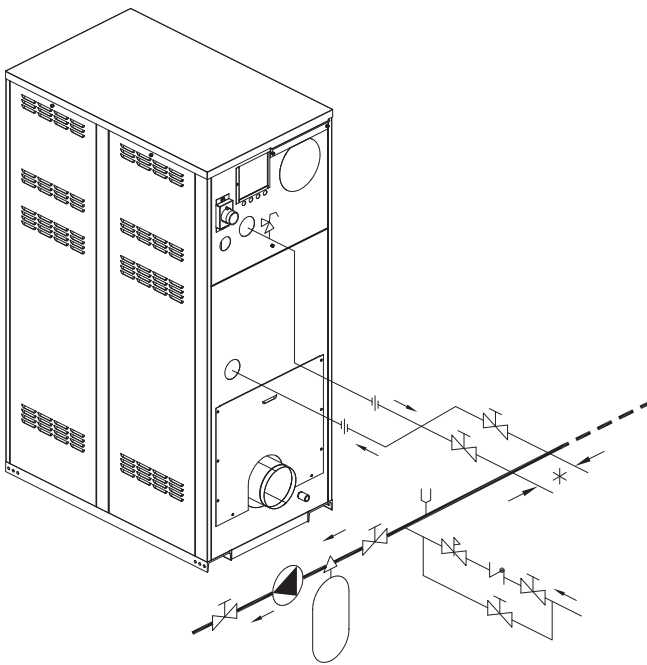

*Maximum 4 times the pipe diameter or 12", whichever is less.

Fig. 14: Single Heater with Primary/Secondary Piping

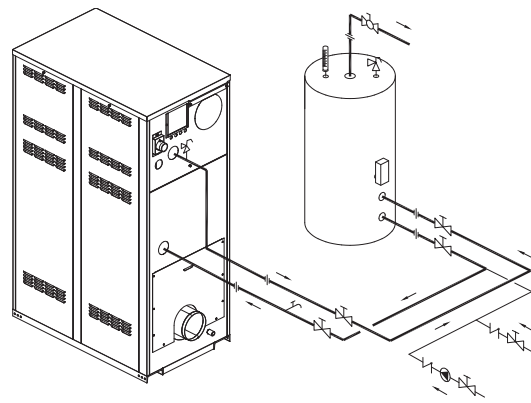

Fig. 16: Single Domestic Hot Water Heater and Storage Tank

NOTE: If local codes require a vacuum relief valve, acquire one locally and install per valve manufacturer's instructions.

Combined Potable Water and Space Heating

CAUTION: When this heater is used for both potable water and space heating, observe the following to ensure proper operation.

1. All piping materials and components connected to the water heater for the space heating application shall be suitable for use with potable water.
2. Toxic chemicals, such as used for boiler treatment, shall not be introduced into the potable water used for space heating.
3. If the heater will be used to supply potable water, it shall not be connected to any heating system or components previously used with a non-potable water heating appliance.
4. When the system requires water for space heating at temperatures higher than 140°F (60°C), a means such as a mixing valve shall be installed to temper the water in order to reduce scald hazard potential.

Pool Heating

When a boiler or water heater is used in a pool heating application, ensure that all the following installation requirements are met.

The XTherm must be equipped with a direct coupled Cold Water Run injector pump for pool applications. The integral wet rotor injector pump system supplied with all H and model 1005 WH XTherm heaters must not be used for pool service. The direct coupled Cold Water Run injector pump package is optional on all H and 1005 WH models and standard on 1505 and 2005 WH and all P and WHP models. The Cold Water Run system must be set to maintain 120°F at the inlet to the primary heat exchanger on all XTherm models.

To complete installation of the heater, the system sensor must be installed in the return water line, upstream of the heater. The supplied electronic operating control is configured to operate as the thermostat. A separate auto limit is shipped loose to be installed in the system piping downstream of the heater outlet. See Fig. 17 for the thermostat/sensor location.

WARNING: To ensure safe operation of the XTherm pool heater, all plumbing from the heater to the main loop must be CPVC, copper or brass.

CAUTION: Power to the heater should be interlocked with the main system pump to make sure the heater does not fire without the main system pump in operation. Improper flow control can damage the heater. Uncontrolled flow (too high) or restricted flow (too low) can seriously damage the heater. Follow these instructions to make sure the heater is properly installed.

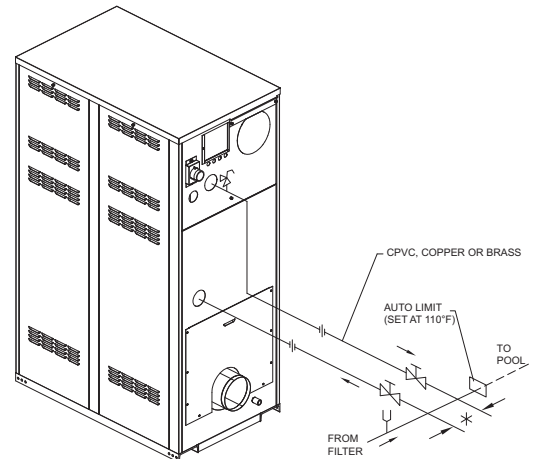

*Maximum 4 times the pipe diameter or 12", whichever is less.

Fig. 17: Single Pool Heater Application

Mode 2 is used for pool installations. For multiple-heater installations, use an external staging sequencer. Connect the sensor provided with the heater across pins 1 and 2 of the field wiring terminal strip. Leave the sensor in the heater cabinet and set the Boil Target to its maximum setting.

Automatic Chlorinators and Chemical Feeders

CAUTION: Combustion air must not be contaminated by corrosive chemical fumes which can damage the heater and void the warranty.

All chemicals must be introduced and completely diluted into the pool or spa water before being circulated through the heater. Do not place chlorine tablets or bromine sticks in the skimmer. High chemical concentrations will result when the pump is not running (e.g. overnight). Chlorinators must feed downstream of the heater and have an anti-siphoning device to prevent chemical back-up into the heater when the pump is shut off.

NOTE: High chemical concentrates from feeders and chlorinators that are out of adjustment will cause very rapid corrosion of the heat exchanger in the heater. Such damage is not covered under the warranty.

Tank Return Temp (°F)	Model 1005				Model 1505				Model 2005			
	Soft/Med Sup. Temp ¹ (°F)	Hard Sup. Temp ¹ (°F)	Minimum Tubing Size ²		Soft Sup. Temp ¹ (°F)	Med Sup. Temp ¹ (°F)	Hard Sup. Temp ¹ (°F)	Minimum Tubing Size ²		Soft/Med Sup. Temp ¹ (°F)	Minimum Tubing Size ²	
			<80' equiv.	80-200' equiv.				<80' equiv.	80-200' equiv.		<80' equiv.	80-200' equiv.
60	138	135	2"	2 1/2"	150	145	143	2"	2 1/2"	154	2"	2 1/2"
80	138	135	2"	2 1/2"	150	145	143	2"	2 1/2"	154	2 1/2"	3"
100	138	135	2 1/2"	3"	150	145	143	2 1/2"	3"	154	2 1/2"	3"
120	146	146	2 1/2"	3"	150	146	146	2 1/2"	3"	155	2 1/2"	3"
130	156	156	2 1/2"	3"	156	156	156	2 1/2"	3"	165	2 1/2"	3"
140	166	166	2 1/2"	3"	166	166	166	2 1/2"	3"	175	2 1/2"	3"

¹-Approximate high fire heater outlet temperature based on the specified heater pump and the recommended minimum tubing size.

²-Minimum tubing size based on total equivalent feet of supply and return piping between the tank and heater.

Table H: Hot Water Supply Temperatures and Minimum Pipe Size at Varying Return Temperatures

Winterizing Your Heater

Heaters installed outdoors as pool heaters in freezing climate areas should be shut down for the winter. To shut down the heater, turn off manual main gas valve and main gas shut-off. Close isolation valves. Drain the heater using the hose bibs located on the bottom of both heat exchangers. Disconnect the condensate hose from the stainless steel condensing heat exchanger and drain the condensate trap.

NOTE: There are 3 separate drains on the XTherm that must ALL be drained to protect the heat exchangers. These are accessible by removing the lower front door from the heater for the 2 primary drains and the right-rear panel for the condensing heat exchanger drain. Drain any piping of all water that may experience below-freezing temperatures.

Water Chemistry

CAUTION: Corrosive water voids all warranties.

Recommended Level(s)	Fiberglass Pools	Fiberglass Spas	Other Pool and Spa Types
Water Temperature	68-88°F (20-31°C)	89-104°F (31-40°C)	68-104°F (20-40°C)
pH	7.3-7.4	7.3-7.4	7.6-7.8
Total Alkalinity (ppm)	120-150	120-150	80-120
Calcium Hardness (ppm)	200-300	150-200	200-400
Salt (ppm)	3000 Maximum	3000 Maximum	3000 Maximum
Free Chlorine (ppm)*	2-3	2-3	2-3
Total Dissolved Solids (ppm)	1500 Maximum**	1500 Maximum**	1500 Maximum**

*Free Chlorine **MUST NOT EXCEED 5 ppm!**

**In salt water chlorinated pools, the total TDS can be as high as 4500ppm

NOTE: The allowable concentrations of salt and of the Total Dissolved Solids are lower for the XTherm than for a typical residential pool heater, due to the higher water temperatures at which an XTherm operates.

Table I: Water Chemistry

Occasional chemical shock dosing of the pool or spa should not damage the heater providing the water is balanced.

Automatic chemical dosing devices are usually more efficient in heater water, unless controlled, they can lead to excessive chlorine level which can damage your heater.

Further advice should be obtained from your pool or spa builder, accredited pool shop, or chemical supplier for the correct levels for your water.

Water Hardness - Water Heaters

Raypak water heaters can operate lime/scale-free using potable water with a hardness not exceeding 25 gpg for models 1005 and 1505, and not exceeding 16 gpg for model 2005. Proper operation is achieved by setting the temperature rise/water flow per the guidelines in the installation instructions. If the hardness of the water exceeds the maximum level of 25 gpg special measures must be taken to lower it. Water should be softened to a hardness level no lower than 5 gpg. Water softened as low as 0 to 1 grain per gallon may be under-saturated with respect to calcium carbonate resulting in water that is aggressive and corrosive.

NOTE: Soft = 0–4 grains per gallon; Medium = 5–15 grains per gallon; Hard = 16–25 grains per gallon.

NOTE: Failure of a heat exchanger due to lime scale build-up on the heating surface, low pH or other chemical imbalance is non-warrantable.

Gas Supply

DANGER: Make sure the gas on which the heater will operate is the same type as specified on the heater's rating plate.

Gas Supply Connection

CAUTION: The heater must be disconnected from the gas supply during any pressure testing of the gas supply system at test pressures in excess of 1/2 psi (3.45 kPa).

The heater must be isolated from the gas supply piping system by closing the upstream manual shut-off valve during any pressure testing of the gas supply piping system at test pressures equal to or less than 1/2 psi (3.45 kPa). Relieve test pressure in the gas supply line prior to re-connecting the heater and its

manual shut-off valve to the gas supply line. **FAILURE TO FOLLOW THIS PROCEDURE MAY DAMAGE THE GAS VALVE.** Over-pressurized gas valves are not covered by warranty. The heater and its gas connections shall be leak-tested before placing the appliance in operation. Use soapy water for leak test. DO NOT use an open flame.

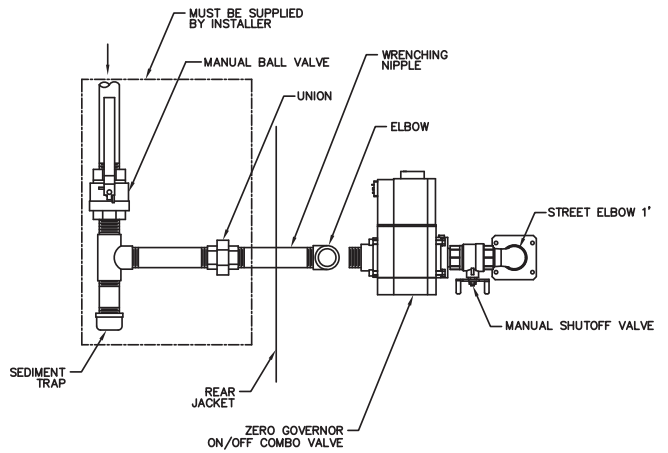

Fig. 18: Gas Supply Connection

CAUTION: Do not use Teflon tape on gas line pipe thread. A pipe compound rated for use with natural and propane gases is recommended. Apply sparingly only on male pipe ends, leaving the two end threads bare.

CAUTION: Support gas supply piping with hangers, not by the heater or its accessories. Make sure the gas piping is protected from physical damage and freezing, where required.

Gas piping *must* have a sediment trap ahead of the heater gas controls, *and* a manual shut-off valve located outside the heater jacket. It is recommended that a union be installed in the gas supply piping adjacent to the heater for servicing.

Model No.	1-1/4" NPT		1-1/2" NPT		2" NPT		2-1/2" NPT	
	N	P	N	P	N	P	N	P
1005	35	55	35	90	125	300	300	
1505	10	15	15	25	60	150	150	275
2005					35	90	85	210

Natural Gas – 1,000 BTU/ft³, 0.60 specific gravity at 0.5 in. WC pressure drop
 Propane Gas – 2,500 BTU/ft³, 1.53 specific gravity at 0.6 in. WC pressure drop

Table J: Maximum Equivalent Pipe Length

Gas Supply Pressure

A pounds-to-inches regulator must be installed to reduce the gas supply pressure if it is higher than 1/2 psi. This regulator should be placed a minimum distance of 10 times the pipe diameter upstream of the heater gas controls. Refer to Table J for maximum equivalent pipe lengths.

When connecting additional gas utilization equipment to the gas piping system, the existing piping must be checked to determine if it has adequate capacity for the combined load. The gas valve pressure regulator on the heater is nominally preset as noted in Table K.

During normal operation, carbon dioxide should be 9.0% ± .1% at full fire for natural gas and 10.0% ± .2% for propane gas. Carbon monoxide should be <100ppm.

Model No.	Manifold Gas Pressure (High Fire Values)	
	Natural Gas	Propane Gas
1005	-1.1	-0.6
1505	-1.6	0.3
2005	-1.8	-2.0

NOTE: Manifold pressures should be ±0.2 in. WC.

Table K: Manifold Gas Pressure Settings

Electrical Power Connections

Installations must follow these codes:

- National Electrical Code and any other national, state, provincial or local codes or regulations having jurisdiction.
- Safety wiring must be NEC Class 1.
- Heater must be electrically grounded as required by the NEC.
- In Canada, CSA C22. 1 C.E.C. Part 1.

XTherm heaters are wired for 120VAC single phase power. Models 1005 and 1505, except WH 1505 models equipped with a heater pump for hard water, require 20A service for the heater and 15A service for the heater pump or a single 40A rated circuit. Model 1505 heaters equipped for hard water require 15A service for the heater and 30A service for the heater pump or a single 50A rated circuit. Model 2005 heaters require 25A service for the heater and 25A service for the heater pump, or a single 50A service. Consult the wiring diagram shipped with the heater. Use appropriately sized wire as defined by NEC, CSA and/or local codes. All primary wiring should be rated for 125% of the minimum required service. Before starting the heater, verify that the correct 120VAC voltage is being supplied to the heater and pump.

If any of the original wire supplied with the heater must be replaced, it must be replaced with 105°C or its equivalent.

Power is connected to the heater via the rear wiring box as shown at the top of Fig. 19. Main heater power is connected to terminals 1, 2 and 3 and pump power is connected to terminals 4, 5 and 6.

Field wiring connections such as sensors, interlocks, enable/disable and alarm contacts are made at the low voltage terminal strip at the front of the heater as shown at the bottom of Fig. 19.

Field-Connected Controllers

It is strongly recommended that all individually-powered control modules and the heater should be supplied from the same power source.

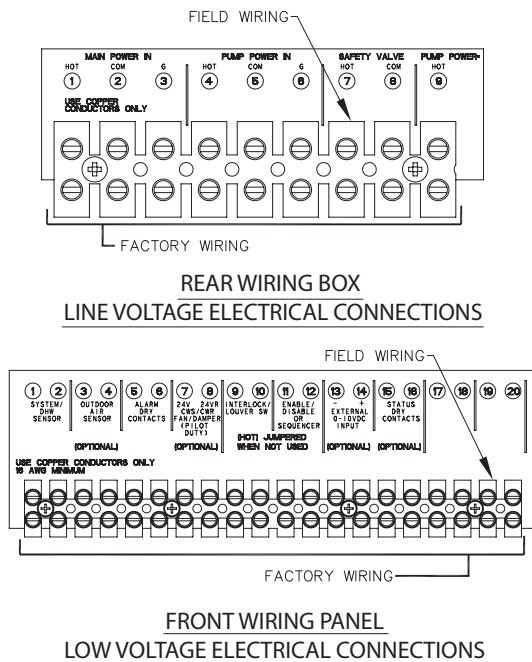

Fig. 19: Wiring Electrical Connections

NOTE: Field-supplied isolation relays should be installed when field-connected controllers are mounted more than a total of 50 equivalent feet (18 AWG) from heater.

NOTE: Minimum 18 AWG, 105°C, stranded wire must be used for all low voltage (less than 30 volts) external connections to the unit. Solid conductors should not be used because they can cause excessive tension on contact points. Install conduit as appropriate. All high voltage wires must be the same size (105°C, stranded wire) as the ones on the unit or larger.

Check the Power Source

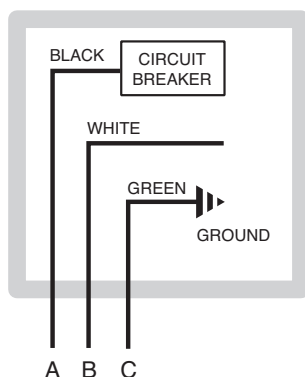

Fig. 20: Wiring Connections

WARNING: Using a multi-meter, check the following voltages at the circuit breaker panel prior to connecting any equipment. Make sure proper polarity is followed and house ground is proven. (See Fig. 20.)

Check the power source:

AC = 108 VAC Minimum, 132 VAC MAX
AB = 108 VAC Minimum, 132 VAC MAX
BC = <1 VAC Maximum

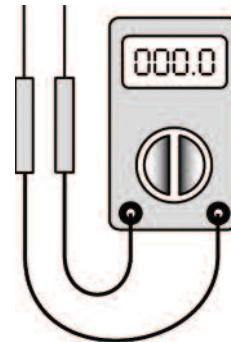

Fig. 21: Multi-meter

Making the Electrical Connections

Refer to Fig. 19-22.

1. Verify that circuit breaker is properly sized by referring to heater rating plate. A dedicated circuit breaker should be provided.
2. NOTE: Current draw noted on rating plate does not include pump current.
3. Turn off all power to the heater. Verify that power has been turned off by testing with a multi-meter prior to working with any electrical connections or components.
4. Observe proper wire colors while making electrical connections. Many electronic controls are polarity sensitive. Components damaged by improper electrical installation are not covered by warranty.
5. Provide overload protection and a disconnect means for equipment serviceability as required by local and state code.
6. Install heater controls, thermostats, or building management systems in accordance with the applicable manufacturers' instructions.
7. Conduit should not be used as the earth ground.

NOTE: A grounding electrode conductor shall be used to connect the equipment grounding conductors, the equipment enclosures, and the grounded service conductor to the grounding electrode.

Field Wiring Connection

CAUTION: Label all wires prior to disconnection when servicing controls. Wiring errors can cause improper and dangerous operation. Verify proper operation after servicing.

DANGER: SHOCK HAZARD

Make sure electrical power to the heater is disconnected to avoid potential serious injury or damage to components.

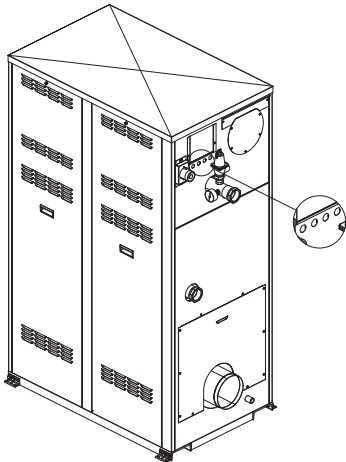

Fig. 22: Rear Wiring Location

Venting

CAUTION: Proper installation of flue venting is critical for the safe and efficient operation of the heater.

General

Appliance Categories

Heaters are divided into four categories based on the pressure produced in the exhaust and the likelihood of condensate production in the vent.

Category I – A heater which operates with a non-positive vent static pressure and with a vent gas temperature that avoids excessive condensate production in the vent.

Category II – A heater which operates with a non-positive vent static pressure and with a vent gas temperature that may cause excessive condensate production in the vent.

Category III – A heater which operates with a positive vent pressure and with a vent gas temperature that avoids excessive condensate production in the vent.

Category IV – A heater which operates with a positive vent pressure and with a vent gas temperature that may cause excessive condensate production in the vent.

See Table L for appliance category requirements.

NOTE: For additional information on appliance categorization, see appropriate ANSI Z21 Standard and the NFGC (U.S.), or B149 (Canada), or applicable provisions of local building codes.

CAUTION: Condensate drains for the vent piping are required for installations of the XTherm. Follow vent manufacturer instructions for installation and location of condensate drains in the vent. Condensate drain trap must be primed with water to prevent gas flue leak and must be routed to an appropriate container for neutralization before disposal, as required by local codes.

WARNING: Condensate is acidic and highly corrosive.

WARNING: Contact the manufacturer of the vent material if there is any question about the appliance categorization and suitability of a vent material for application on a Category IV vent system. Using improper venting materials can result in personal injury, death or property damage.

Use only the special gas vent pipes listed for use with Category IV gas burning heaters, such as the AL29-4C stainless steel vents offered by Heat Fab Inc. (800-772-0739), Protech System, Inc. (800-766-3473), Z-Flex (800-654-5600) or American Metal Products (800-423-4270). Pipe joints must be positively sealed. Follow the vent manufacturer's installation instructions carefully.

Centrotherm polypropylene vent material is approved to be used on XTherm products. A vent adapter supplied by Raypak (option D-33) must be used to ensure a proper seal of the flue and condensate. The D-33 kit includes a required vent temperature limit.

WARNING: All venting types must be of the same material or product throughout the entire exhaust installation to ensure proper securing and sealing.

Combustion Air Supply	Exhaust Configuration	Heater Venting Category	Certified Materials	Combustion Air Inlet Material
From Inside Building (Non-Direct Venting)	Vertical Venting	IV	CAT IV (AL29-4C) PVC CPVC Polypropylene*	
	Horizontal Through-the-Wall Venting			
From Outside Building (Direct Venting)	Vertical Venting			Galvanized Steel PVC ABS CPVC
	Horizontal Through-the-Wall Venting			

* Only Centrotherm polypropylene material is approved for use with the XTherm.

Table L: Venting Category Requirements

Support of Vent Stack

The weight of the vent stack or chimney must not rest on the heater vent connection. Support must be provided in compliance with applicable codes. The vent should also be installed to maintain proper clearances from combustible materials. Use insulated vent pipe spacers where the vent passes through combustible roofs and walls.

Vent Terminal Location

1. Condensate can freeze on the vent cap. Frozen condensate on the vent cap can result in a blocked flue condition.

NOTE: During winter months check the vent cap and make sure no blockage occurs from build-up of snow or ice.

2. Give special attention to the location of the vent termination to avoid possibility of property damage or personal injury.
3. Gases may form a white vapor plume in winter. The plume could obstruct a window view if the termination is installed near windows.
4. Prevailing winds, in combination with below-freezing temperatures, can cause freezing of condensate and water/ice build-up on buildings, plants or roofs.
5. The bottom of the vent terminal and the air intake shall be located at least 12 in. above grade, including normal snow line.
6. Un-insulated single-wall Category IV metal vent pipe shall not be used outdoors in cold climates for venting gas-fired equipment without insulation.

7. Through-the-wall vents for Category IV appliances shall not terminate over public walkways or over an area where condensate or vapor could create a nuisance or hazard or could be detrimental to the operation of regulators, relief valves, or other equipment.
8. Locate and guard vent termination to prevent accidental contact by people or pets.
9. DO NOT terminate vent in window well, stairwell, alcove, courtyard or other recessed area.
10. DO NOT terminate above any door, window, or gravity air intake. Condensate can freeze, causing ice formations.
11. Locate or guard vent to prevent condensate from damaging exterior finishes. Use a rust-resistant sheet metal backing plate against brick or masonry surfaces.
12. DO NOT extend exposed vent pipe outside of building beyond the minimum distance required for the vent termination. Condensate could freeze and block vent pipe.

U.S. Installations

Refer to the latest edition of the National Fuel Gas Code.

Vent termination requirements are as follows:

1. Vent must terminate at least 4 ft below or 4 ft horizontally from any door, window or gravity air inlet to the building.
2. The vent must not be less than 7 ft above grade when located adjacent to public walkways.
3. Terminate vent at least 3 ft above any forced air inlet located within 10 ft.

4. Vent must terminate at least 4 ft horizontally, and in no case above or below unless 4 ft horizontal distance is maintained, from electric meters, gas meters, regulators, and relief equipment.
5. Terminate vent at least 6 ft away from adjacent walls.
6. DO NOT terminate vent closer than 5 ft below roof overhang.
7. The vent terminal requires a 12 in. vent terminal clearance from the wall.
8. Terminate vent at least 1 ft above grade, including normal snow line.
9. Multiple direct vent installations require a 4 ft clearance between the ends of vent caps located on the same horizontal plane.
7. Within 3 ft (915 mm) of a window or door which can be opened in any building, any non-mechanical air supply inlet to any building or the combustion air inlet of any other appliance.
8. Underneath a verandah, porch or deck, unless the verandah, porch or deck is fully open on a minimum of two sides beneath the floor, and the distance between the top of the vent termination and the underside of the verandah, porch or deck is greater than 1 ft (305 mm).

WARNING: The Commonwealth of Massachusetts requires that sidewall vented heaters, installed in every dwelling, building or structure used in whole or in part for residential purposes, be installed using special provisions as outlined on page 54 of this manual.

WARNING: Examine the venting system at least once a year. Check all joints and vent pipe connections for tightness, corrosion or deterioration.

Venting Installation Tips

Support piping:

- horizontal runs—at least every 5 ft (1.5m)
- vertical runs—use braces
- under or near elbows

Canadian Installations

Refer to latest edition of the B149 Installation Code.

A vent shall not terminate:

1. Directly above a paved sidewalk or driveway which is located between two single-family dwellings and serves both dwellings.
2. Less than 7 ft (2.13 m) above a paved sidewalk or paved driveway located on public property.
3. Within 6 ft (1.8 m) of a mechanical air supply inlet to any building.
4. Above a meter/regulator assembly within 3 ft (915 mm) horizontally of the vertical centre-line of the regulator.
5. Within 6 ft (1.8 m) of any gas service regulator vent outlet.
6. Less than 1 ft (305 mm) above grade level.

Venting Configurations

For heaters connected to gas vents or chimneys, vent installations shall be in accordance with the NFGC (U.S.), or B149 (Canada), or applicable provisions of local building codes.

Vertical Venting (Category IV)

CAUTION: This venting system requires the installation of a condensate drain in the vent piping per the vent manufacturer's instructions. Failure to install a condensate drain in the venting system will void all warranties on this heater. Condensate is acidic and highly corrosive.

Installation

The maximum and minimum venting length for this Category IV appliance shall be determined per the NFGC (U.S.) or B149 (Canada).

The diameter of vent flue pipe should be sized according to the NFGC (U.S.) and Appendix B of B149 (Canada). The minimum flue pipe diameter for conventional venting using Category IV, stainless steel AL29-4C vent is: 6 in. (152mm) for Model 1005 and 8 in. (203mm) for Models 1505 and 2005.

The connection from the appliance vent to the stack must be as direct as possible and shall be the same di-

Model No.	Certified Vent Material	Vent Size (in.)	Total Effective Length ¹ (ft)		Combustion Air Intake Pipe Material	Air Inlet Max. Length* (ft)		
			Min.	Max.		6" Ø	8" Ø	10" Ø
1005	Category IV (AL29-4C) PVC CPVC Polypropylene***	6	0	75 ²	Galvanized Steel, PVC, ABS, CPVC	45	100**	
1505		8						
2005							45	85**

¹ Vent lengths are based on a lateral length of 2 ft. Refer to the latest edition of the NFGC for further details.

² Consult factory for longer vent runs.

* Subtract 10 ft per elbow. Max. 4 elbows.

** Adapters supplied by others.

*** Only Centrotherm polypropylene material is approved for use with the XTherm.

Table M: Category IV Venting

ameter as the vent outlet. The horizontal breaching of a vent must have an upward slope of not less than 1/4 inch per linear foot from the heater to the vent terminal. The horizontal portions of the vent shall also be supported for the design and weight of the material employed to maintain clearances and to prevent physical damage or separation of joints.

NOTE: A vent adapter (field-supplied) may be required to connect the Category IV vent to the heater.

Termination

The vent terminal should be vertical and should terminate outside the building at least 2 ft above the highest point of the roof that is within 8 ft. The vent cap should have a minimum clearance of 4 ft horizontally from and in no case above or below (unless a 4 ft horizontal distance is maintained) electric meters, gas meters, regulators and relief equipment.

The distance of the vent terminal from adjacent public walkways, adjacent buildings, open windows and building openings must be consistent with the NFGC (U.S.) or B149 (Canada). Gas vents supported only by flashing and extended above the roof more than 5 ft should be securely guyed or braced to withstand snow and wind loads.

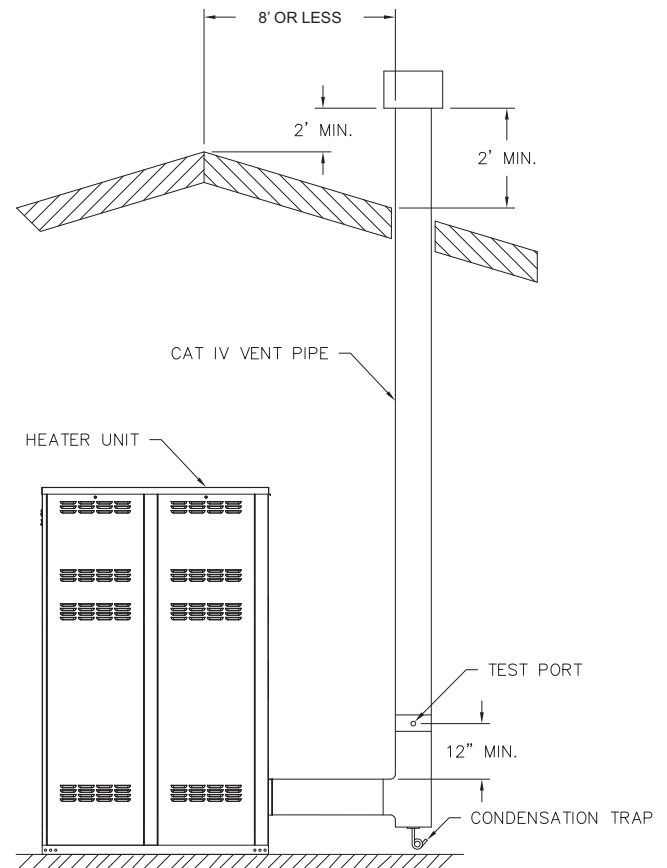

Fig. 23: Vertical Venting

CAUTION: A listed vent cap terminal suitable for connection to the Cat IV vent materials, adequately sized, must be used to evacuate the flue products from the heaters. Cap design must prevent rain water from entering stack.

NOTE: For extractor sizing, typical CO₂ levels are 8.5% for natural gas and 9.5% for propane gas and flue temperature of 150° F.

Common Venting

The NFGC does not address sizing guidelines for the common venting of multiple Category IV heaters. This is covered in the NFGC under “Engineered Vent Systems”. Table N provides the volume of flue products at full fire for the calculation of appropriate vent sizing and extractor for common venting.

WARNING: Vent connectors serving any other appliances shall not be connected into any portion of mechanical draft systems operating under a positive pressure. If an XTherm heater is installed to replace an existing heater, the vent system MUST be verified to be of the correct size and of one of the Category IV vent materials identified in Table M. If it is NOT, it MUST be replaced. If PVC vent is to be used, reference the instructions starting on page 30.

Model No.	Vent Size (in.)	Volume of Flue Products (CFM)
1005	6	260
1505	8	390
2005	8	520

* NOTE: Data for 100% firing rate.

Table N: Volume of Flue Products Data

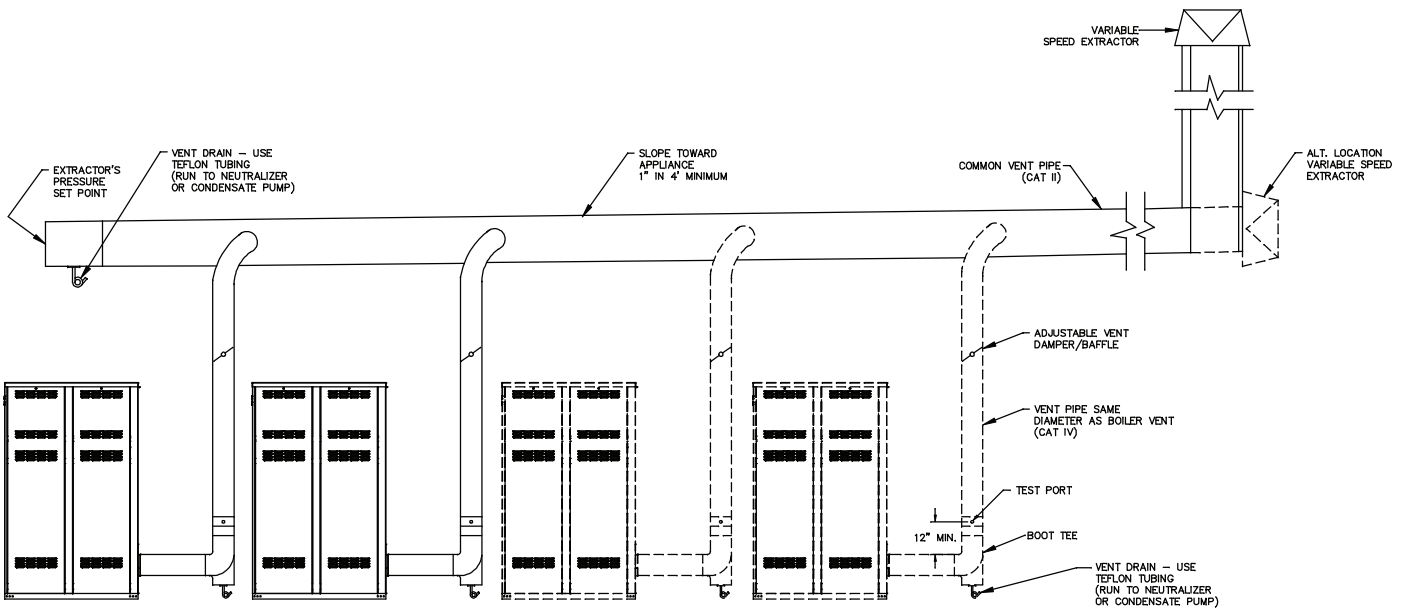

Note: Units rotated 90° for clarity. Typical multi-unit installations have the heaters installed side-by-side. Extractor is required.

Fig. 24: Typical Common Venting

Horizontal Through-the-Wall and Direct Venting (Category IV)

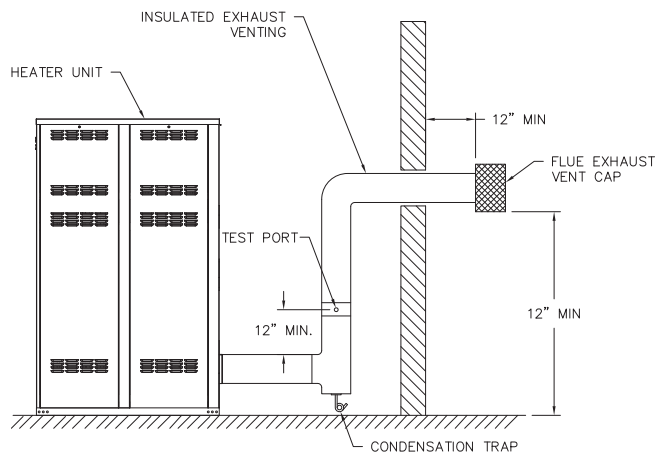

Fig. 25: Horizontal Through-the-Wall Venting

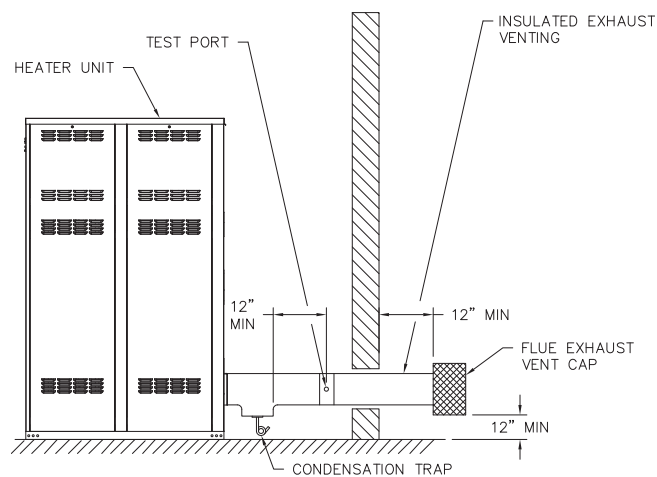

Fig. 26: Alt. Horizontal Through-the-Wall Venting

NOTE: While a drain connection is required in the vent of all XTherm installations, the drain can be accomplished in several different ways. The figures in this manual show the drain in a vent tee, however, this can also be accomplished using an inline collector for condensing stacks or an inline vertical or horizontal collector available from several of the listed vent manufacturers.

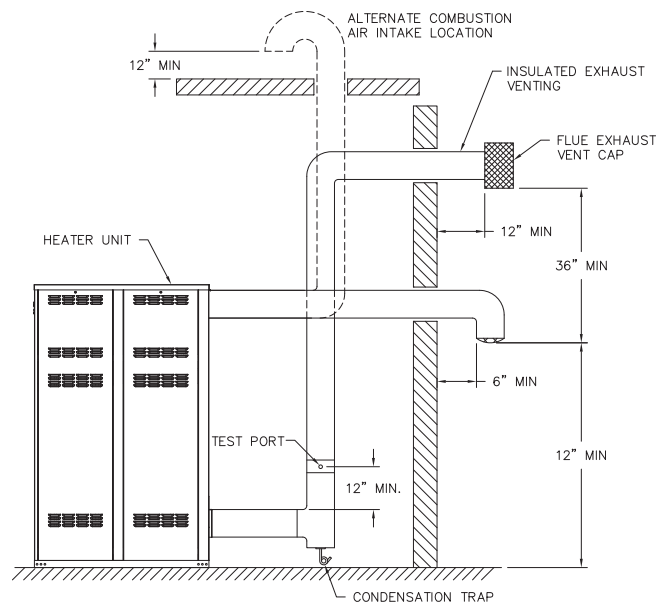

Fig. 27: Horizontal Through-the-Wall Direct Venting

CAUTION: This venting system requires the installation of a condensate drain in the vent piping per the vent manufacturer's instructions. Failure to install a condensate drain in the venting system will void all warranties on this heater. Condensate is acidic and highly corrosive.

Installation

These installations utilize the heater-mounted blower to vent the combustion products to the outdoors. Combustion air is taken from inside the room and the vent is installed horizontally through the wall to the outdoors. Adequate combustion and ventilation air must be supplied to the equipment room in accordance with the NFGC (U.S.) or B149 (Canada).

The total length of the horizontal through-the-wall flue system should not exceed 75 equivalent ft in length. If horizontal run exceeds 75 equivalent ft, an appropriately sized variable-speed extractor must be used. Each elbow used is equal to 10 ft of straight pipe. This will allow installation in one of the four following arrangements:

- 75' of straight flue pipe
- 65' of straight flue pipe and one elbow
- 55' of straight flue pipe and two elbows
- 45' of straight flue pipe and three elbows

The vent cap is not considered in the overall length of the venting system.

The vent must be installed to prevent flue gas leakage. Care must be taken during assembly to ensure that all joints are sealed properly and are airtight. The vent must be installed to prevent the potential accumulation of condensate in the vent pipes. It is required that:

1. The vent must be installed with a condensate drain located in proximity to the heater as directed by the vent manufacturer.
2. The vent must be installed with a slight upward slope of not less than 1/4 inch per foot of horizontal run to the vent terminal.
3. The vent must be insulated through the length of the horizontal run.

Termination

The flue direct vent cap **MUST** be mounted on the exterior of the building. The direct vent cap cannot be installed in a well or below grade. The direct vent cap must be installed at least 1 ft above ground level and above normal snow levels. The Raypak-approved stainless steel flue direct vent cap **MUST** be used (sales order option D-15). The vent terminal must be located **NO CLOSER** than 12" off the wall, and the discharge screens **MUST** discharge horizontally. The long axis of the D-15 vent cap must **NOT** be vertical or at an angle from horizontal.

WARNING: No substitutions of flue pipe or vent cap material are allowed. Such substitutions would jeopardize the safety and health of inhabitants.

Direct Vent—Vertical

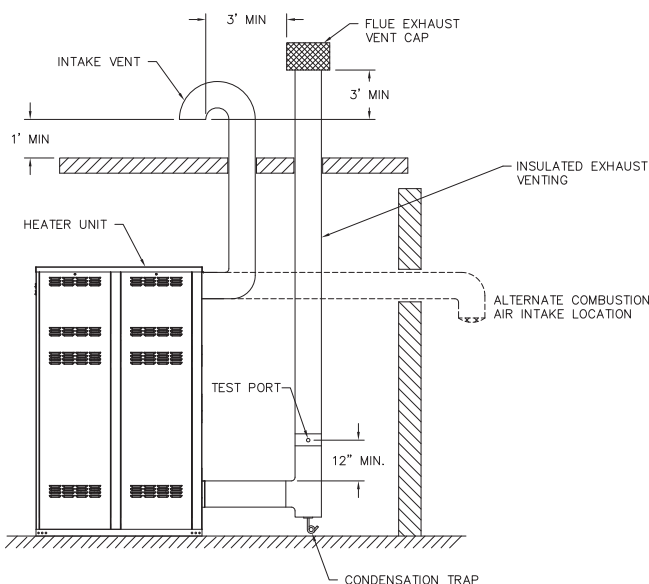

Fig. 28: Direct Vent - Vertical

CAUTION: This venting system requires the installation of a condensate drain in the vent piping per the vent manufacturer's instructions. Failure to install a condensate drain in the venting system will void all warranties on this heater. Condensate is acidic and highly corrosive

Installation

These installations utilize the heater-mounted blower to draw combustion air from outdoors and vent combustion products to the outdoors.

The total length of air supply pipe cannot exceed the distances listed in Table M. Each elbow used is equal to 10 ft of straight pipe. This will allow installation in any arrangement that does not exceed the lengths shown in Table M. The vent cap is not considered in the overall length of the venting system.

Care must be taken during assembly that all joints are sealed properly and are airtight.

The vent must be installed to prevent the potential accumulation of condensate in the vent pipes. It is required that:

1. The vent must be installed with a condensate drain located in proximity to the heater as directed by the vent manufacturer.
2. The vent must be installed with a slight upward slope of not more than 1/4 inch per foot of horizontal run to the vent terminal.
3. The vent must be insulated through the length of the horizontal run.

Termination

The vent cap **MUST** be mounted on the exterior of the building. The vent cap cannot be installed in a well or below grade. The vent cap must be installed at least 1 ft above ground level and above normal snow levels.

The vent cap **MUST NOT** be installed with any combustion air inlet directly above a vent cap. This vertical spacing would allow the flue products from the vent cap to be pulled into the combustion air intake installed above.

This type of installation can cause non-warrantable problems with components and poor operation of the heater due to the recirculation of flue products. Multiple vent caps installed in the same horizontal plane must have a 4 ft clearance from the side of one vent cap to the side of the adjacent vent cap(s).

Combustion air supplied from outdoors must be free of particulate and chemical contaminants. To avoid a blocked flue condition, keep the vent cap clear of snow, ice, leaves, debris, etc.

WARNING: No substitutions of flue pipe or vent cap material are allowed. Such substitutions would jeopardize the safety and health of inhabitants.

Outdoor Installation

XTherm heaters are certified for outdoor operation in non-freezing conditions only. Freezing conditions may cause condensate to freeze in the condensate drain line and trap causing the unit to shut down from a blocked condensate drain. Additionally, components of the condensate management system may be damaged by the ice formation. Units installed in freezing climates for seasonal use must be winterized to avoid freeze damage to the heater.

Outdoor models must be vented with listed vent material per the following instructions and installed with the optional factory-supplied outdoor vent kit. A special vent cap is provided in accordance with CSA requirements. It must be installed directly on the vent pipe as illustrated in Fig. 29 on page 30.

Care must be taken when locating the heater outdoors, because the flue gases discharged from the vent cap can condense as they leave the cap. Improper location can result in damage to adjacent structures or building finish. For maximum efficiency and safety, the following precautions must be observed:

1. Outdoor models must be installed outdoors and must use the outdoor vent cap and air intake hood available from the manufacturer (sales order option D-11).
2. Periodically check venting system. The heater's venting areas must never be obstructed in any way and minimum clearances must be observed to prevent restriction of combustion and ventilation air. Keep area clear and free of combustible and flammable materials.

3. Do not locate adjacent to any window, door, walkway, or gravity air intake. The vent must be located a minimum of 4 ft horizontally from such areas.
4. Install above grade level and above normal snow levels.
5. Vent terminal must be at least 3 ft above any forced air inlet located within 10 ft.
6. Adjacent brick or masonry surfaces must be protected with a rust-resistant sheet metal plate.

NOTE: The vent cap and air intake hood must be furnished by the heater manufacturer in accordance with its listing (sales order option D-11).

NOTE: Condensate can freeze on the vent cap. Frozen condensate on the vent cap can result in a blocked flue condition. Condensate is acidic and highly corrosive

NOTE: Centrotherm polypropylene vent material cannot be used for outdoor installations.

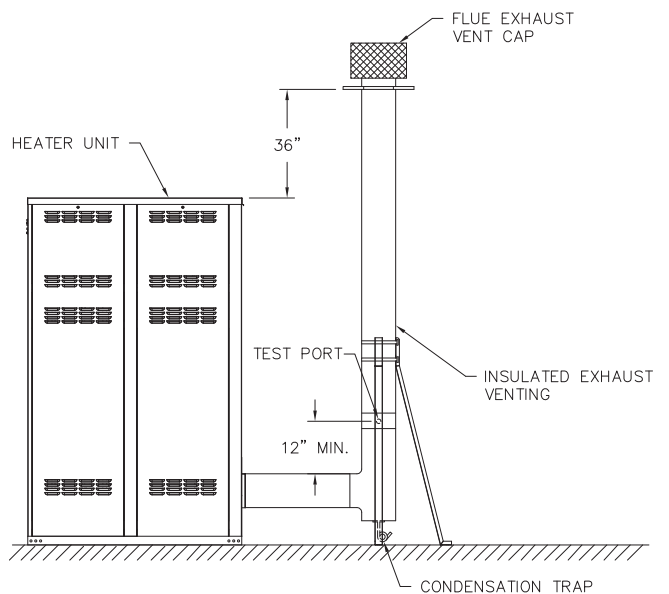

Fig. 29: Outdoor Venting

Freeze Protection

The Raypak electronic temperature control includes a freeze protection feature. In the event the water temperature drops below 40°F at any of the heater temperature sensors, the pump is turned on and will remain on until the temperature at all heater sensors rises to 45°F.

WARNING: Do not install the heater outdoors if freezing conditions are typical. The condensate will freeze and back up the flue system.

PVC Venting Option (D-32)

Venting of the XTherm with PVC material requires the factory installed D-32 adapter kit. The PVC vent option requires a 200°F manual reset high limit.

CAUTION: The inlet water temperature to the XTherm must not exceed 170°F at any firing rate to use the PVC venting option. The venting system must conform to local codes and/or the current National Fuel Gas Code ANSI Z223.1/NFPA 54. The system setpoint must not exceed 180°F.

The PVC vent adapter should appear as in Fig. 30.

Cleaning

Prior to installing the PVC pipe and fittings, ensure that all burrs and/or ridges have been removed. Failure to remove burrs or ridges will result in the cement in the fitting socket being scraped from the socket surface, producing a dry joint with a high probability of joint failure. Remove all burrs with a knife, or with abrasive paper.

Surfaces to be joined must be cleaned and be free of dirt, moisture, oil, and other foreign materials.

DANGER: Primer, cleaner, and cements are extremely flammable. They are harmful or fatal if swallowed. The vapors are harmful. They may irritate eyes and skin and can be absorbed through the skin. Read and observe all safety information printed on primer, cleaner, and cement containers.

PRECAUTIONS: Always store primers, cleaner, and cements in cool, dry, well ventilated places. Do not store them near heat, sparks, or flames. Keep containers closed. Use them in well ventilated areas. Wear impervious clothing while handling. Do not smoke, eat, or drink while handling. Wash thoroughly after handling and before eating. Wear eye protection when handling. If swallowed, drink water, do not induce vomiting, and call a physician or poison control center immediately. If inhaled, get fresh air and seek medical attention if ill feelings persist. In case of eye and/or skin contact, immediately flush with plenty of water for 15 minutes and seek medical attention if irritation persists.

All primers, cleaners, and cements must meet all local codes.

- Before using primers, cleaners, and cements, stir or shake, making sure contents are liquid. Do not use if found to be lumpy or jelly-like.
- Restoration of the original viscosity or removal of gelation by adding solvents or thinners is not recommended.
- Primers and/or cement should be NSF and/or UPC listed.

NOTE: Cleaners and primers are intended for different functions and should not be considered interchangeable. Verify with vent material manufacturer for specific requirements.

Termination

Termination should be accomplished using the adapter thimble as shown. The adapter thimble is supplied by Raypak as part of the D-32 option.

PVC vent assembly instructions

- 1) Cut pipe ends squarely, removing all burrs and dirt.
- 2) Dry fit pipe and fittings to be connected for proper fit.
- 3) Clean pipe and fitting with a cleaner.
- 4) Apply a coat of primer to pipe and fitting.
- 5) Apply a thin coat of cement to fitting, avoiding puddling inside.
- 6) Apply a liberal coat of cement to pipe leaving no voids.

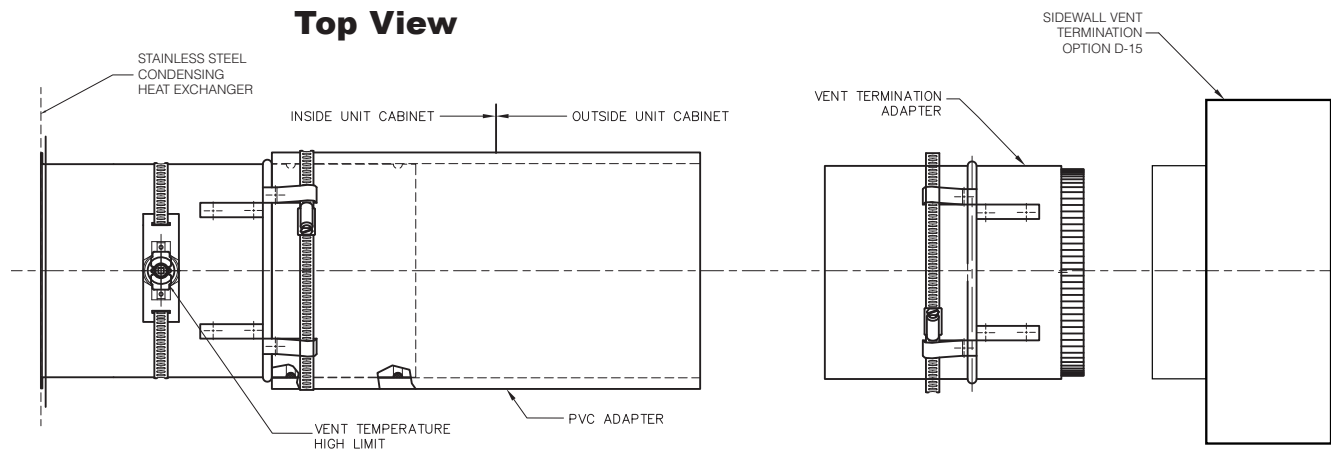

Fig. 30: PVC Vent Adapter

- 7) QUICKLY assemble parts while cement is fluid! If you wait too long, re-coat pipes.
- 8) Push pipe completely into socket of fitting, rotating 1/4 turn to achieve proper orientation until it bottoms out.
- 9) Hold pipe and fitting together for 30 seconds, then carefully clean off excess with a cloth. The glue bonds by melting the PVC and they will re-harden during curing.
- 10) Allow connections a sufficient time to cure before disturbing (follow manufacturer instructions).
- 11) A special sidewall vent adapter/termination must be used as supplied by Raypak per our listing.
- 12) Rooftop installations must use a category IV listed vent cap.

WARNING: Vent pipes must be adequately and securely supported; the vent weight must not be supported by the heater; this may cause unwarrantable damage.

Centrotherm Polypropylene Venting Option (D-33)

Venting of the XTherm with Polypropylene vent material requires the D-33 adapter kit available from Raypak.

CAUTION: The inlet water temperature to the XTherm must not exceed 190°F at 100% fire to use the Polypropylene venting option. The venting system must conform to local codes and/or the current edition of the National Fuel Gas Code ANSI Z223.1/NFPA 54.

The Polypropylene vent adapter should appear as in Fig. 31.

Cleaning

Prior to installing Polypropylene pipe and fittings, ensure that all gaskets are free of grease, oil, debris or damage.

Installation

Vent pipes are joined by push-fit connections, with EPDM gaskets located in the sockets. Pipes and components must be installed with the socket ends to the outlet and male ends towards the appliance.

It is not recommended to install polypropylene when the material temperature is below 32°F.

Joining

Lubricate gaskets and male ends of pipes with CENTROCERIN lubricant or water only.

Push male ends of pipes into gasketed openings with a light twisting motion.

Cutting

Components should be selected to minimize cutting. Where it is necessary, pipe sections may be cut to length at male ends (non-socketed end) only. Any cuts must be made at right angles to the pipe. Pipe must then be beveled for insertion into the adjoining socket to ease installation. All field cuts must be deburred. Bends and other pre-formed components must not be cut.

Termination

Termination should be accomplished using the adapter as shown. The appliance and termination adapters are interchangeable. The vent temperature limit provided with the adapter must be installed per kit instructions.

Polypropylene Construction

- ULC-S636 Certified, making it approved for use in Canada
- Zero Clearance to Combustibles

Storage

Components should be stored in a clean, dry environment in their original packaging. Non-UV stabilized plastic components must be protected from prolonged exposure to UV light.

Appliance Start-Up

Once polypropylene installation is complete, the heating system and flue should be commissioned following Raypak's instructions. There is no cure time or wait time required.

WARNING: Verify that vent pipes are adequately and securely supported; the vent weight must not be supported by the heater; this may cause unwarrantable damage.

Controls

WARNING: Installation, adjustment and service of heater controls, including timing of various operating functions, must be performed by a qualified installer, service agency or the gas supplier. Failure to do so may result in control damage, heater malfunction, property damage, personal injury, or death.

WARNING: Turn off the power to the heater before installation, adjustment or service of any heater controls. Failure to do so may result in board damage, heater malfunction, property damage, personal injury, or death.

CAUTION: This appliance has provisions to be connected to more than one supply source. To reduce the risk of electric shock, disconnect all such connections before servicing.

CAUTION: Risk of electric shock: More than one disconnect switch may be required to de-energize the equipment before servicing.

The Raypak modulating temperature control is provided to maintain the desired system water temperature. The control has various modes of operation which are described on the following pages.

The XTherm is designed for use with Primary/Secondary pumping only, utilizing integral injector pumps to maintain proper flows and temperatures in the heater.

Top View

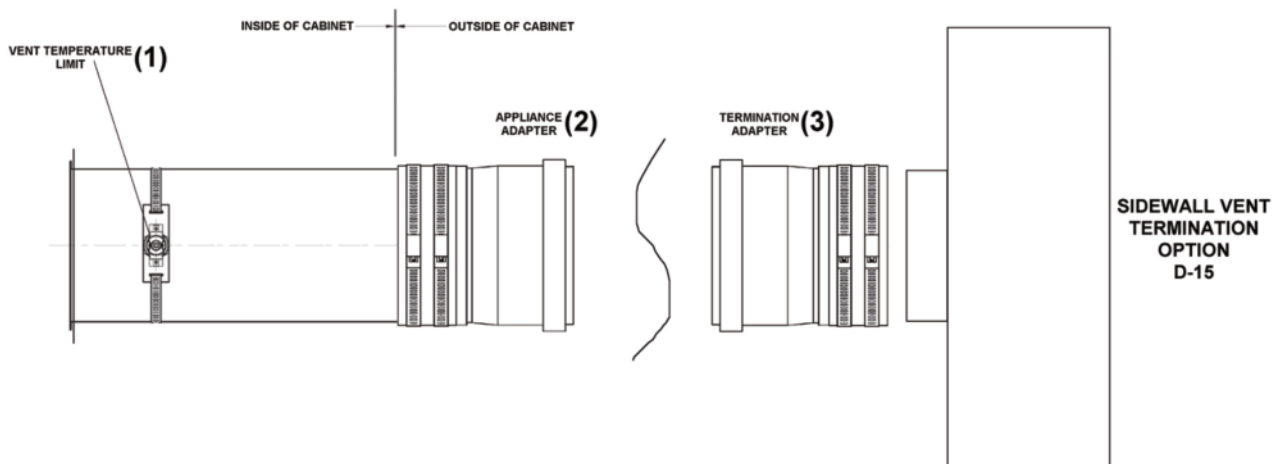

Fig. 31: Centrotherm Polypropylene Vent Adapter

Setpoint: The intended system supply temperature.

Deadband: Deadband is a band of temperature sensing where no action occurs. All temperature controllers have a deadband and the purpose is to prevent short-cycling of the heater. The on-board temperature controller has a deadband of 2°F around the target.

Differential: A heat source must be operated with a temperature differential in order to prevent short-cycling. The temperature differential is divided around the “target” temperature or set-point. The Call For Heat (CFH) contact will close in the controller when the water temperature is below the target temperature by 1/2 of the differential setting, and will open when the water temperature is above the target temperature by 1/2 of the differential setting. See Fig. 32.

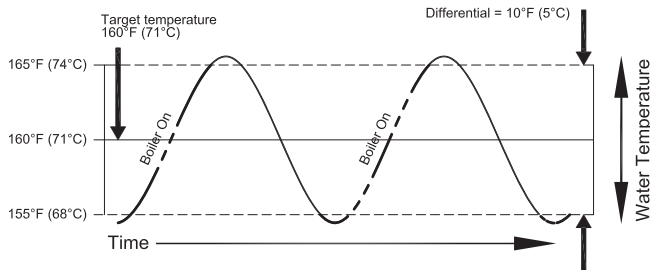
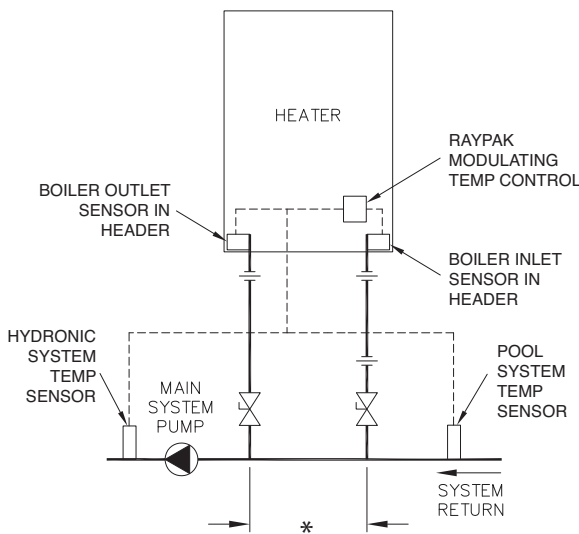

Fig. 32: Differential Graph

Operating Modes

Mode 1 – Primary piping is prohibited.

Mode 2 – Setpoint operation using primary/secondary piping, used for either hydronics or pool systems. The control operates the heater to satisfy a remote system sensor. The heater is turned off based on boiler max and boiler differential (factory default). See Fig. 33.



*Maximum 4 times the pipe diameter or 12", whichever is less.

Fig. 33: Mode 2 Primary/Secondary Piping

Mode 3 – Dedicated DHW operation using UniTemp 80 piping. A call for heat is determined by the DHW sensor and the DHW boiler target. The heater outlet water is also controlled to the boiler target temperature. See Fig. 34.

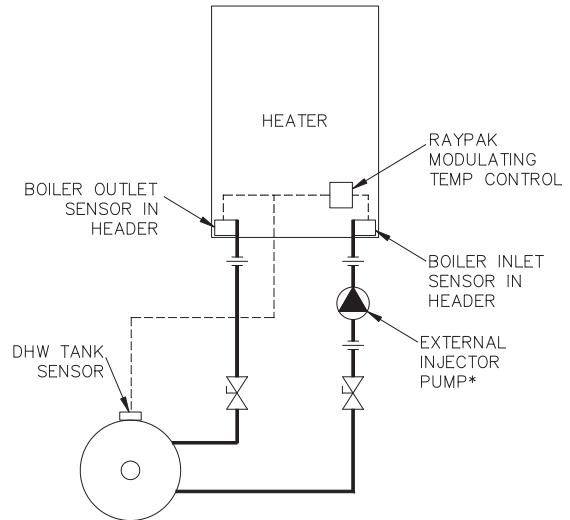
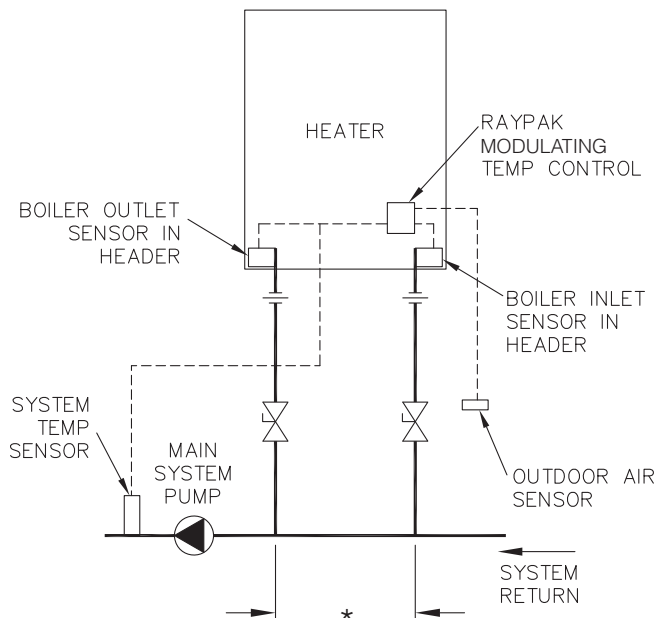

Fig. 34: Mode 3 Dedicated DHW

Mode 4 – Primary piping with outdoor reset is prohibited.

Mode 5 – Outdoor reset using primary/secondary piping. The heater is operated as in Mode 2. However, the target temperature is based on outdoor reset. See Fig. 35.



*Maximum 4 times the pipe diameter or 12", whichever is less.

Fig. 35: Mode 5 Primary/Secondary Piping with Outdoor Reset

Mode 6 – Primary piping is prohibited.

Mode 7 – Designed for an external input signal with primary/secondary piping. The external input signal can be provided from a BMS, an EMS or a sequencing control. The external input signal changes the boiler target according to a linear scale. The control operates the boiler burner to maintain the boiler target at the remote system sensor. See Fig. 36.

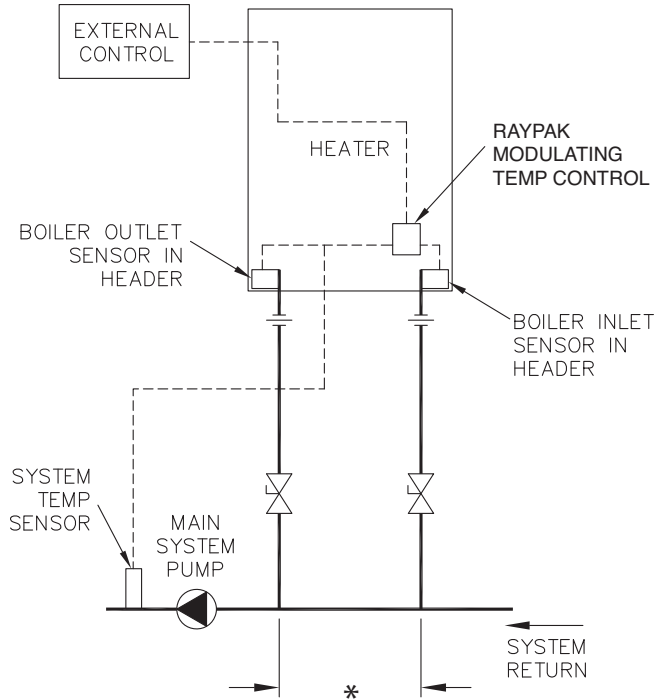

*Maximum 4 times the pipe diameter or 12", whichever is less.

Fig. 36: Mode 7 Primary/Secondary Piping with External Target Temp

Mode 8 – This mode is for remote firing control of the heater via an external sequencer such as the Raypak TempTracker MOD+. The heater is enabled via dry contact at the Enable/Disable connection at the low voltage terminal strip, and the firing rate is controlled by a 0-10 VDC signal from the external sequencer. A control signal of ≥ 0.5 VDC equates to minimum fire, and a signal of 10 VDC equates to 100% firing rate. The onboard controller is no longer providing control of system water temperature. Only sequence of operation is provided by the onboard controller in this mode.

NOTE: For Modes 7 and 8, connect to pins 13 and 14 on the low-voltage panel. See page 21. Use these modes for systems using an external signal.

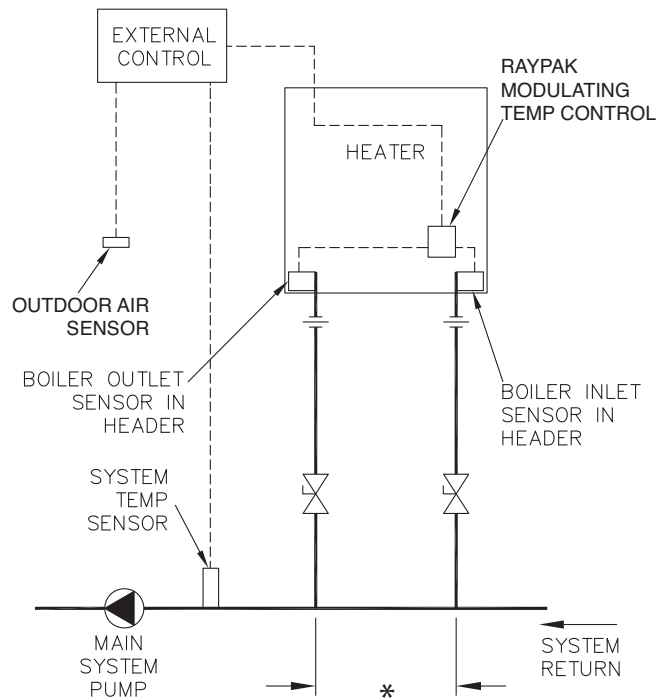

*Maximum 4 times the pipe diameter or 12", whichever is less.

Fig. 37: Mode 8 Primary/Secondary Piping with External Direct Drive

Recommended Settings for Pool Heater (P & WHP) Applications		
Item	Modes	Recommended Setting
Boil Target	OFF, 70°F to 106°F	78°F
Boil Max	110°F, 70°F to 106°F	86°F
Boil Min	OFF, 40°F to 106°F	70°F
'Burner' Delay	0:00 to 3:00 min.	0:00 min
Boil Mass	1(Low)-2(Med)-3(Hi)	1 (Low)
Diff	1°F to 3°F	2°F
'Pump' Dly	OFF, 0:20 to 9:55 min, ON	3:00 min
Units	°F or °C	°F
Mode	2	2

Table O: Recommended Temperature Control Setpoints—WHP Models

Item	Modes	Default Setting	Range
Boil Target	2	160°F	OFF, 70 to 220°F
	3	160°F	OFF, 70 to 190°F
	5, 7	180°F	OFF, 70 to 220°F
Boil Max	2, 5, 7	200°F	OFF, 120 to 225°F
	3	180°F	OFF, 120 to 190°F
Boil Min	2, 3, 5, 7	150°F	OFF, 80 to 180°F
'Burner' Delay	All	0:00 min	0:00 to 3:00 min
Boil Mass	All	1 (Low)	1 (Low), 2 (Med), 3 (High)
Diff	2, 3, 5, 7	Auto	Auto, 2 to 42°F
DHW Target	3	120°F	OFF, 70 to 190°F
DHW Diff	3	5°F	2 to 10°F
'Pump' Dly	All	3:00 min	OFF, 0:20 to 9:55 min, ON
Outdr Start	5	70°F	35 to 85°F
Outdr Design	5	-10°F	-60 to 32°F
Boil Start	5	135°F	35 to 150°F
Boil Dsgn	5	180°F	120 to 220°F
WWSD	5	70°F	35 to 100°F
Units	All	°F	°F or °C
Mode	N/A	2	1, 2, 3, 4, 5, 6, 7, 8
External Input Signal	7	2 to 10 VDC	2 to 10 VDC or 0 to 10 VDC
Offset	7	0°F	-10°F to 10°F

Table P: Temperature Control Default Setpoints—H7 & WH7 Models

0-10 VDC	0-20 mA*	Boiler Target
0	0	--- (OFF)
1	2	50°F
2	4	68.9°F
3	6	87.8°F
4	8	106.7°F
5	10	125.6°F
6	12	144.1°F
7	14	163.3°F
8	16	182.2°F
9	18	201.1°F
10	20	220°F

*Requires a 500Ω resistor.

Table Q: 0-10 VDC or 0-20 mA External Input Signal

2-10 VDC	4-20 mA*	Boiler Target
0	0	--- (OFF)
1	2	--- (OFF)
2	4	50°F
3	6	71.3°F
4	8	92.5°F
5	10	113.8°F
6	12	135°F
7	14	156.3°F
8	16	177.5°F
9	18	198.8°F
10	20	220°F

*Requires a 500Ω resistor.

Table R: 2-10 VDC or 4-20 mA External Input Signal

Temperature (°F)	Resistance (Ω)
-50	490,813
-40	336,606
-30	234,196
-20	165,180
-10	118,018
0	85,362
10	62,465
20	46,218
30	34,558
40	26,099
50	19,900
60	15,311
70	11,883
77	10,000
80	9,299
90	7,334
100	5,828
110	4,665
120	3,760
130	3,050
140	2,490
150	2,045
160	1,689
170	1,403
180	1,172
190	983
200	829
210	703
220	598

Table S: Sensor Resistance

Definitions

NOTE: The defined terms are not active in all modes of control operation.

% OUT - Current percent modulation rate of heater.

BOIL DSGN - Design boiler water temperature used in heat loss calculations.

BOIL MASS - This setting allows adjustment in the field for high or low thermal masses; High thermal mass (setting=3) provides slower reaction, lower thermal mass (setting=1) provides faster reaction.

BOIL MAX - Highest water temperature that the control is allowed to use as a target temperature.

BOIL MIN - Lowest water temperature that the control is allowed to use as a target temperature.

BOIL ON - Accumulated runtime of heater (up to 999 hours, then resets to 0).

BOIL OUT - Actual heater outlet water temperature.

BOIL START - Starting boiler water temperature.

BOIL SUP - Actual system supply water temperature.

BOIL TARGET - Target temperature that the heater is trying to maintain.

'BURNER' DELAY - Holds control output at ignition setting from the start of the ignition sequence to the specified burner delay time (0 to 3:00 min.).

DEM 1 - Indicates 24 VAC signal has been supplied to the H+D terminal.

DEM 2 - Indicates 24 VAC Flame Proof signal is present.

DIFF - The operating differential of the heater; The heater outlet water temperature is allowed to rise above the BOIL TARGET temperature by ½ of this differential before the heater shuts off. For example, if the heater target temperature is set to 160°F (71°C) and the differential is set to 10°F (5°C), on temperature rise, the heater will shut off at 165°F (74°C). Once the heater shuts off, it will not come on again until the temperature falls to 155°F (68°C).

EXTERNAL INPUT SIGNAL – Selects external input signal range (0-10VDC or 2-10VDC):

Rank	Item Field	Number Field	Type	Fault Description
0	E01	Err	Error	EEPROM error
1	FP	Err	Warning	Flame proof warning
2	BOIL OUT	SHr	Error	Boiler outlet sensor short
3	BOIL OUT	OPn	Error	Boiler outlet sensor open
4	BOIL IN	SHr	Error	Boiler inlet sensor short
5	BOIL IN	OPn	Error	Boiler inlet sensor open
6	SUP	SHr	Error	System sensor short
7	SUP	OPn	Error	System sensor open
8	OUTDR	SHr	Error	Outdoor sensor short
9	OUTDR	OPn	Error	Outdoor sensor open
10	DHW	SHr	Error	DHW sensor short
11	DHW	OPn	Error	DHW sensor open

Table T: Error Codes

0-10VDC or 0-20 mA external input signal – When the 0-10VDC signal is selected, an input voltage of 1 VDC corresponds to a boiler target temperature of 50°F (10°C). An input voltage of 10 VDC corresponds to a boiler target temperature of 220°F (104°C). As the voltage varies between 1 VDC and 10 VDC, the boiler target temperature varies linearly between 50°F (10°C) and 220°F (104°C). If a voltage below 0.5 VDC is received, the boiler target temperature is displayed as “– – –” indicating that there is no longer an internal heat demand. A 0-20 mA signal can be converted to a 0-10 VDC signal by installing a 500 Ω resistor on the external input signal device’s terminals.

2-10VDC or 4-20 mA external input signal – When the 2-10VDC signal is selected, an input voltage of 2 VDC corresponds to a boiler target temperature of 50°F (10°C). An input voltage of 10 VDC corresponds to a boiler target temperature of 220°F (104°C). As the voltage varies between 2 VDC and 10 VDC, the boiler target temperature varies linearly between 50°F (10°C) and 220°F (104°C). If a voltage below 1.5 VDC is received, the boiler target temperature is displayed as “– – –” indicating that there is no longer an internal heat demand. A 4-20 mA signal can be converted to a 2-10 VDC signal by installing a 500 Ω resistor on the external input signal device’s terminals.

FP - Flame proof warning. Warns that the control did not see burner flame within 5 min. of call for heat.

MODE - Operating mode of the heater.

OFFSET - The Offset setting allows the boiler target temperature to be fine tuned to the external input signal. The control reads the external input signal and converts this to a boiler target temperature. The Offset setting is then added to the boiler target temperature.

OUTDR - Outdoor air temperature.

OUTDR DESIGN - Design outdoor air temperature used in the heat loss calculation.

OUTDR START - Starting outdoor air temperature.

PUMP DLY - Sets the operating time of the pump once the CFH is satisfied.

TANK - Current DHW tank temperature (Mode 3).

TANK DIFF - Storage tank differential (Mode 3).

TANK TARGET - Target temperature in the DHW storage tank (Mode 3).

UNITS - Selects the temperature units to be displayed (°F or °C).

WWSD - Selects the outdoor temperature that shuts the heater off, no matter what the demand. NOTE: The WWSD segment is displayed on the LCD.

Operation

The Raypak modulating temperature control uses a Liquid Crystal Display (LCD) as a method of supplying information. The LCD is used to setup and monitor system operation by means of three push buttons (*Item*, and) shown at the bottom of Fig. 38.

All items displayed by the control are organized into two menus, the view menu and the adjust menu. The active menu is displayed in the upper right hand side of the display in the menu field. The default menu is the view menu.

When the temperature control is powered up, the control turns on all segments in the display for 2 seconds, then the software version is displayed for 2 seconds. At the end of that 4 second period, the control enters the normal operating mode and "VIEW" is displayed. Pressing the scroll button "scrolls" through the displayed values in the "VIEW" menu.

To make an adjustment to a setting in the control, begin by selecting the "ADJUST" menu. To change from the view menu to the adjust menu, simultaneously press and hold all three buttons for 1 second. The menu name, "ADJUST" will be displayed in the menu field.

The menu will automatically revert back to the view menu after 20 seconds of keyboard inactivity. Then scroll to the desired item using the scroll button. Finally, use the or button to make the adjustment. In the absence of other information, the values provided in Tables R and S should be used as default settings.

Heater Sequence of Operation

If all limits are satisfied and there is a call for heat:

1. The internal heater primary pump will start and begin circulating water in the heater's primary heat exchanger and the injector pump(s) will be powered and enabled.
2. The blower is powered and goes through a 15 second prepurge from when air flow is proven by closure of the blower suction air pressure switch.
3. The igniter will be powered and once proven will heat up for 20 seconds.
4. The gas valve is then energized for a 4 second trial for ignition period. Trial for ignition is fixed at 50% input. The heater is allowed to modulate once flame is proven and the firing rate will adjust to match the load based on the configuration and settings of the temperature control or external input.
5. As the water approaches 120°F entering the primary heat exchanger the injector pumps will begin feeding water from the system into the heater, operating to maintain 120°F minimum into the primary heat exchanger.
6. Once the heat demand is satisfied the gas valve will close and the blower will run a 30-second post purge. The heater pump will continue to circulate water for 0 to 10 minutes depending on the pump delay setting on the Raypak modulating temperature control.

Ignition Module

When additional heat is needed, the combustion air blower starts to purge air from the combustion chamber for 15 seconds. On proof-of-air flow, the air-proving switch closes and the igniter is energized. To ensure safe operation, the gas valve cannot open until the igniter is verified. The main burner is automatically lit when the device is powered and pre-purged. The heater performs its own safety check and opens the main valve only after the igniter is proven to be capable of ignition. The standard ignition module will attempt to light three times before locking out. To reset it, turn off power to the heater, wait 30 seconds and re-apply power.

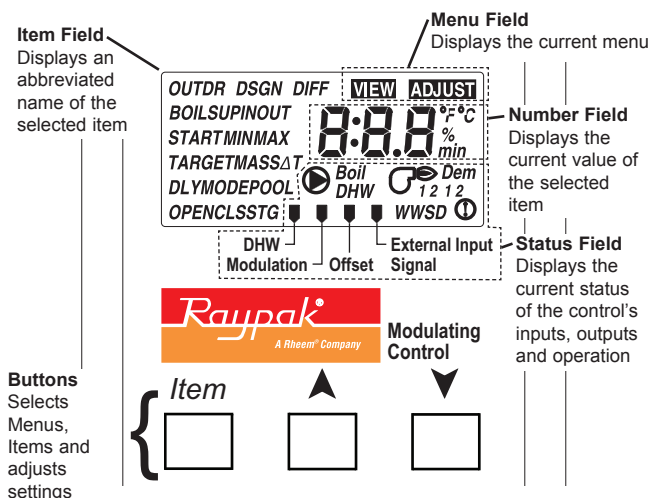

Fig. 38: Modulating Temperature Control Display

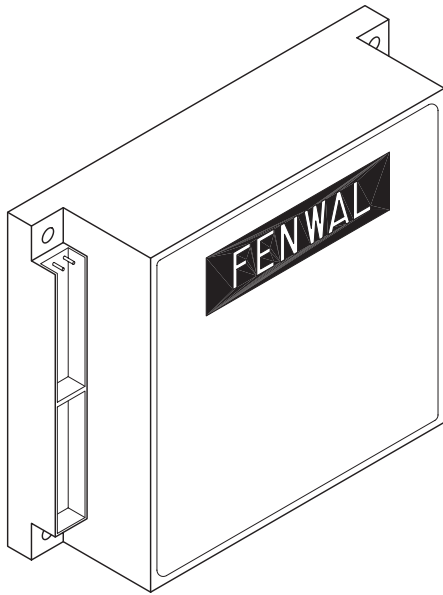

Fig. 39: Ignition Module

The optional single-try ignition module will lock out after failing to light one time. To reset it, press and release the small, recessed black push button located inside of the cut-out on the lower right-hand corner of the ignition module case. **Turning off the power to the heater WILL NOT reset the single-try ignition module.**

Code	Condition
On	System OK; No faults present
Off	Possible control fault; Check power
1 Flash	Low air
2 Flashes	Flame in combustion chamber; No call for heat
3 Flashes	Ignition lockout
4 Flashes	Low HSI current
5 Flashes	Low 24 VAC
6 Flashes	Internal fault; Replace control

Table U: Ignition Module Diagnostic LED Flash Codes

High Limit—Manual Reset

This heater is equipped with a fixed setting manual reset high limit temperature device as standard or it may have an optional adjustable setting manual reset high temperature device.

The fixed setting manual reset high limit is located on the In/Out header of the heat exchanger on the right side of the heater (accessible through the front door for reset as necessary).

The optional adjustable manual reset high limit is located inside the heater junction box. Push the reset button and adjust the setting to approx. 40°F (20°C) above desired outlet temperature.

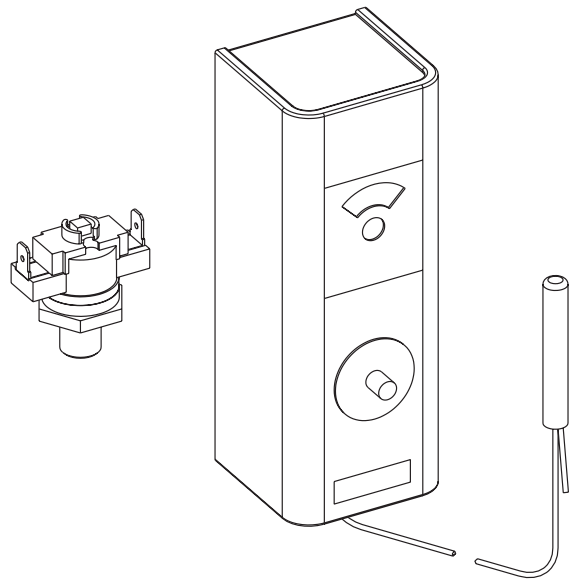

Fig. 40: High Limit (Manual Reset)

High Limit—Auto Reset (Optional)

This heater may be equipped with an optional adjustable auto reset high limit temperature device.

For H and WH systems, the optional adjustable auto reset high limit is located inside the heater junction box. Adjust the setting to approx. 20°F (10°C) above desired outlet temperature.

For Pool installations, the auto limit must be located to sense the water temperature in the main line (see Fig. 17). Adjust the setting no higher than 110°F.

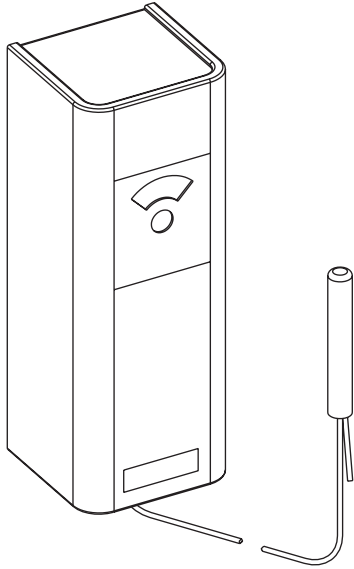

Fig. 41: Adjustable High Limit (Auto Reset)

Flow Switch

This standard, dual-purpose control, mounted and wired in series with the main gas valve, shuts off the heater in case of pump failure or low water flow.

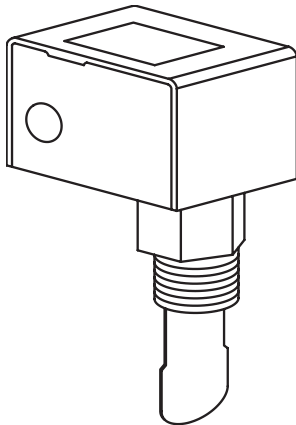

Fig. 42: Flow Switch

Variable Speed Injector Pump

Some XTherm models are equipped with dual variable speed injector pumps, like the one shown below. Fig. 44 shows the DIP switch settings, setpoint and factory wiring.



Fig. 43: Variable Speed Injector Pump

- 1 - OFF
- 2 - ON
- 3 - ON
- 4 - OFF
- 5 - OFF

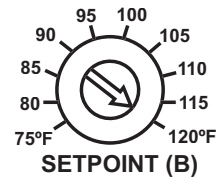
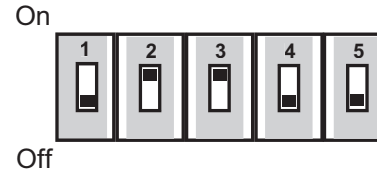

INJECTOR PUMP WIRING

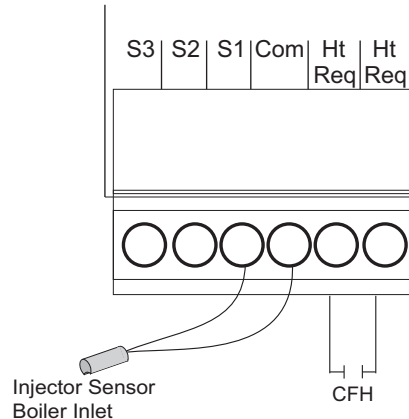

Fig. 44: Injector Pump DIP Switches, Setpoint and Wiring

Modulating Temperature Control

This heater is equipped with a Raypak modulating temperature control. Refer to information starting on page 33 for information on the setting and use of this control.

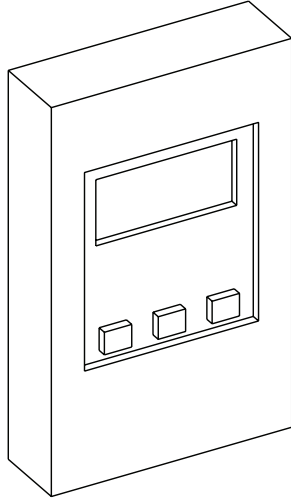

Fig. 45: Modulating Temperature Control

Low Water Cut-Off (Optional)

The optional low water cut-off automatically shuts down the burner whenever water level drops below the level of the sensing probe. A 5-second time delay prevents premature lockout due to temporary conditions such as power fluctuations or air pockets.

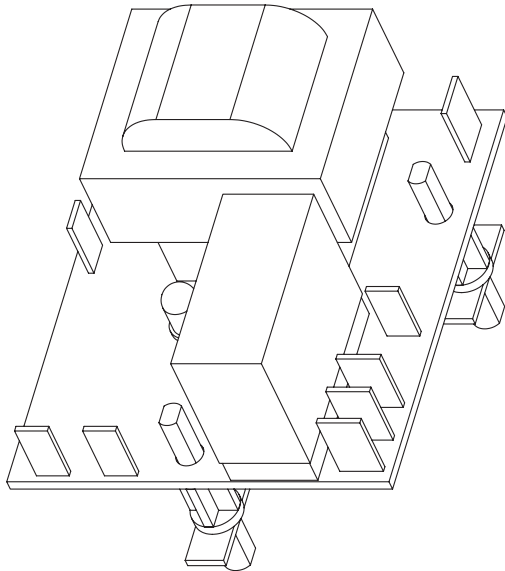

Fig. 46: Low Water Cut-Off

High & Low Gas Pressure Switches (Optional)

The optional low gas pressure switch connection mounts upstream of the gas valve (on the inlet flange to the gas valve) and is accessible through the removable access panel on the right side of the heater to reset the gas pressure switch, as necessary. It is used to ensure that sufficient gas pressure is present for proper valve/regulator performance. The low gas pressure switch automatically shuts down the heater if gas supply drops below the factory setting of 3.0 in. WC for natural gas or propane gas.

The optional high gas pressure switch connection mounts down-stream of the gas valve. Special ports are located on the backside of the gas valve and accessible from the front of the heater (to reset the gas pressure switch) or through the removable access panel on the right side of the heater (to reset the gas pressure switch), as necessary. If the gas pressure regulator in the valve fails, the high gas pressure switch automatically shuts down the burner.

Operation of either the High or Low Gas Pressure Switch will turn on an LED inside the switch housing. Push the top of the plastic switch housing as shown in Fig. 47 to reset a tripped pressure switch. The LED will go out when the switch is reset.

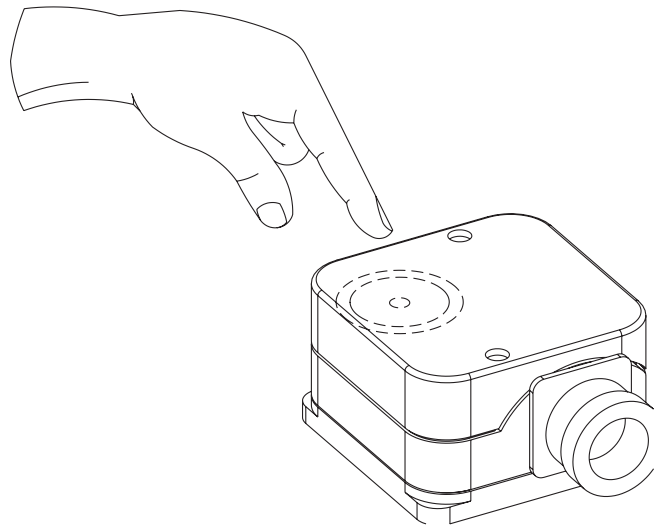

Fig. 47: High/Low Gas Pressure Switch

Air Pressure Switch

This heater is equipped with an air pressure switch to prove the operation of the blower before allowing the ignition control to begin a trial for ignition. It is located on the right side of the lower flange of the blower mounting assembly, directly behind the junction box.

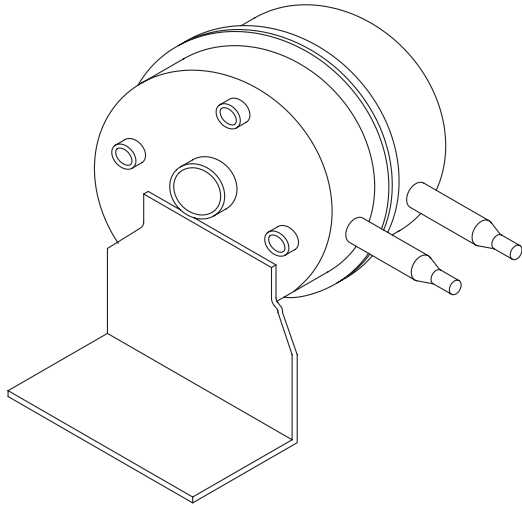

Fig. 48: Air Pressure Switch

Blocked Vent Switch

This heater is equipped with a blocked vent pressure switch to prevent the operation of the heater when too much of the vent is blocked. This switch is located on the right side of the heater near the right rear corner.

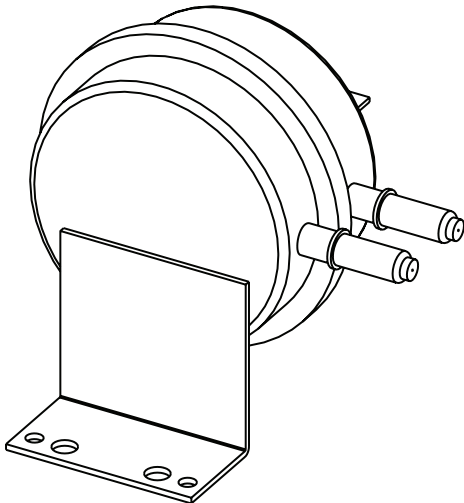

Fig. 49: Blocked Vent Switch

UDB Diagnostic Board

This heater is equipped with a diagnostic board which will indicate faults as they occur. Refer to the Troubleshooting section for instructions on accessing, reviewing and clearing these faults.

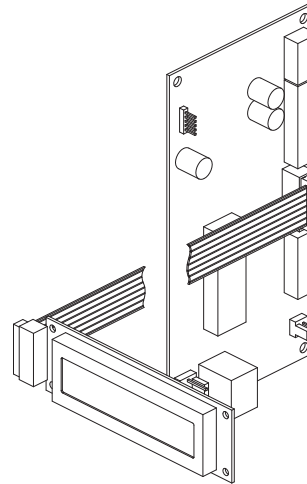

Fig. 50: UDB Diagnostic Board with Display

Condensate Float Switch

This heater is equipped with a condensate float switch to prevent operation when the condensate water level is too high. The heater shutting down from the condensate float switch is indicative of a blocked drain or problem with the condensate management system. The condensate float switch is located inside the vent outlet plenum at the left rear of the heater.

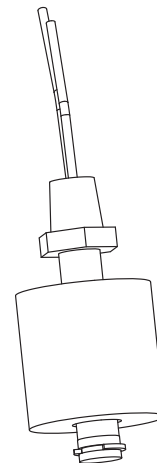

Fig. 51: Condensate Float Switch

NOTE: The wiring diagrams in this manual show all standard options. Refer to the large wiring diagram provided with your heater for options installed on your specific unit(s).

START-UP

Pre Start-up

Filling System (Heating Boilers)

Fill system with water. Purge all air from the system. Lower system pressure. Open valves for normal system operation, and fill system through feed pressure. Manually open air vent on the compression tank until water appears, then close vent.

Air Purge (Domestic Hot Water Heaters)

Purge all air from system before lighting heater. This can be normally accomplished by opening a downstream valve.

XTherm heaters are equipped with an air vent installed in the inlet side of the header to ensure that air is purged from the system. It includes an adapter to allow the air vent to be piped (in the field) to a suitable drain as required by the jurisdiction having authority.

CAUTION: An additional air vent should be installed at the highest point in the system for proper operation. If water piping is located higher than the header, it should be relocated to the highest point in the installed system.

Venting System Inspection

1. Check all vent pipe connections and flue pipe material.
2. Make sure vent terminations are installed per code and are clear of all debris or blockage.
3. Prime condensate traps in the vent system as necessary and verify that the traps and drain lines are free of debris or blockage.

For Your Safety

WARNING: If you do not follow these instructions exactly, a fire or explosion may result causing property damage, personal injury or loss of life.

This appliance has a hot surface igniter. It is equipped with an ignition device which automatically lights the burners. Do not try to light the burners by hand.

BEFORE OPERATING, smell all around the appliance area for gas. Be sure to smell near the floor because some gas is heavier than air and will settle on the floor.

WHAT TO DO IF YOU SMELL GAS:

- Do not try to light any appliance.
- Do not touch any electrical switch; do not use any telephone in your building.
- Immediately call your gas supplier from a neighbor's telephone. Follow the gas supplier's instructions.
- If you cannot reach your gas supplier, call the fire department.
- Use only your hand to push in or turn the gas control knob. Never use tools. If the knob will not turn by hand, do not try to repair it, call a qualified service technician. Forced or attempted repair may result in a fire or explosion.
- Do not use this appliance if any part has been under water, immediately call a qualified service technician to inspect the appliance and to replace any part of the control system and any gas control which has been under water.
- Check around unit for debris and remove combustible products, i.e. gasoline, etc.

Pre Start-up Check

1. Verify the heater is filled with water.
2. Check system piping for leaks. If found, repair immediately.
3. Vent air from system. Air in system can interfere with water circulation.
4. Purge air from gas line to heater.
5. Prime the heater condensate trap mounted in the bottom of the stainless steel condensing heat exchanger.

WARNING: Condensate trap must be primed prior to heater start-up to prevent flue gas leakage through the condensate management system. Verify that traps maintain a prime under operating conditions. Extended operation with non-condensing conditions may require an engineered condensate management system.

Initial Start-up

Required tools

- (1) 12-0-12 (24" scale) U-tube manometer
- (2) 6-0-6 (12" scale) U-tube manometer
- Screwdrivers (assorted sizes and shapes)
- (1) Crescent wrench (8" or 10")
- (1) Multi-meter
- (1) Amp probe

(Metric Allen wrenches will be required for servicing the gas valve, but not during start-up)

NOTE: Digital manometers are not recommended.

Preparation

WARNING: Do not turn on gas at this time.

Check Power Supply

With multi-meter at incoming power, check voltage between:

Hot - Common (≈ 120 VAC)

Hot - Ground (≈ 120 VAC)

Common - Ground (< 1 VAC)

WARNING: If Common - Ground is > 1 VAC, STOP: Contact electrician to correct ground failure. Failure to do this may burn out 120V-24V transformer, or may cause other safety control damage or failure.

Attach Manometers to Measure Pressures

1. Turn off main gas valve.
2. Attach (1) 12" scale manometer to an upstream bleedie valve on the gas supply pipe to the heater (Measure point "A" in Fig. 52).
3. Attach (1) 24" scale manometer to the manifold pressure tap located on the elbow downstream of the valve (Measure point "D" in Fig. 52).
4. Attach (1) 12" scale manometer near the fan-proving switch. Pull black cap from air pressure switch tee and connect the manometer. NOTE: Retain caps for reinstallation later.

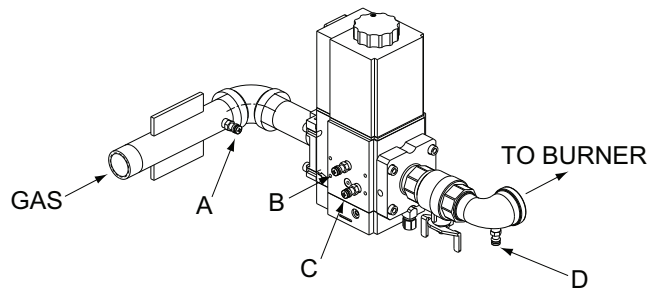

Fig. 52: Gas Pressure Measurement Locations

Check Gas Supply Pressure

1. Slowly turn on main gas shut-off valve.
2. Read the gas supply pressure from the manometer; minimum supply pressure for natural gas is 4.0 in. WC, recommended supply is 7.0 in. WC, minimum supply pressure for propane gas is 4.0 in. WC, recommended supply is 11.0 in. WC (dynamic readings, full fire input).
3. If the gas pressure is greater than 14.0 in. WC, turn off the main gas shut-off valve.

Start-Up

NOTE: The values in Tables V, W and X represent the conditions when the heater is at full firing rate at sea level.

1. Turn power on.
2. Turn on the heater, wait approximately 15 seconds after the blower starts, and the igniter should start to glow (observable through the observation port located at the front, bottom of the heater). Look into the sight glass located at the bottom of the front panel to check igniter operation. Gas valve should open in 45-60 seconds.
3. The heater ignites at 50% of full rate (as indicated on the LCD display of the temperature control located in the upper right of the front panel).
4. If the burner fails to light on the first trial, it will go into lockout with the optional single-try ignition module. If the heater is equipped with the standard three-try ignition module, it will try for ignition up to three times before going into lockout.
5. Wait until the controller indicates 100% on the firing rate display screen (approximately 30 seconds).

Blower Check

1. Check the net blower suction using a 6-0-6 U-tube manometer by connecting one end to the blower suction pressure tee (attached to the negative side of the air pressure switch, point “A” in Fig. 53) and the other end to the tracking pressure tee (attached to the positive side of the air pressure switch, point “B” in Fig. 53). Read the differential pressure with the heater firing at 100% input and compare to Table V.
2. Check the tracking pressure by removing the end of the U-tube manometer from the blower suction pressure tee (point “A” in Fig. 53). Replace the cap on the blower suction tee and check the tracking pressure (at point “B” in Fig. 53) with the heater firing at 100% input. The tracking pressure provides feedback to the gas regulator to compensate for various air ducting arrangements and changes in the pressure drop across the combustion air filter. Initial readings with a clean air filter installed must be recorded on the “Start-up Checklist” located at the back of this manual. When the tracking pressure is more negative than -0.6 in. WC for 1005 and 1505 models or -0.8 in. WC on 2005 models and there are no obstructions to the air intake, replace the combustion air filter. If the air intake is obstructed, shut the unit off, clear the obstruction, re-start and check the tracking pressure as previously noted.

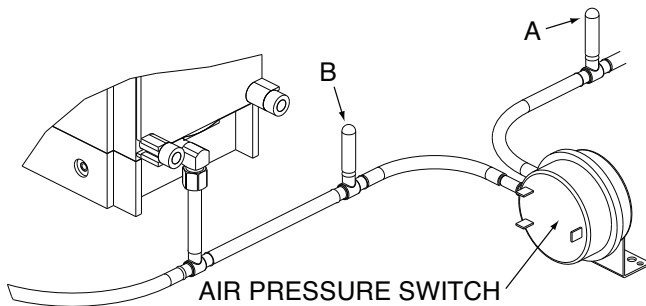

Fig. 53: Air Pressure Measurement Locations

3. **FOR REFERENCE ONLY:** Measure the blower amp draw with the heater firing at 100% input and compare the measured value to the values in Table W. The amp draw is measured with a clamp-on type amp probe clamped to the 14 AWG black power wire going into the blower.

NOTE: Most commercially available amp probes are not accurate enough and/or are not shielded well enough to read accurately in the heater environment. Blower amp draw readings are for reference only.

4. When firing at 100%, the desired heater combustion CO₂ is 9.0% ± .1% at full fire for natural gas and 10.0% ± .2% for propane gas with CO less than 100 ppm. If this combustion cannot be achieved with the net blower suction within the tolerances specified in Table V, contact the factory. The reference amp draw reading may help to indicate if there is a problem with the system or if blower adjustment is required.

Manifold Check

1. Check manifold gas pressure at the gas valve outlet pressure tap (connection “D” in Fig. 51). This pressure should read per the values in Table X for natural and propane gas.
2. If the pressure reading differs by more than ± 0.2 in. WC, **STOP – Call the factory for directions on what to do next!**

Model No.	Net Blower Suction (in. WC)		Setting Tolerance
	Nat.	Pro.	
1005	-4.8	-2.8	± 0.2 in. WC
1505	-3.5	-3.5	± 0.2 in. WC
2005	-4.6	-5.0	± 0.2 in. WC

Table V: XTherm Air Pressure Settings

Model No.	Amp Draw	Setting Tolerance
1005	4.8	+0.2/-0.2
1505	8.1	+0.2/-0.2
2005	13.0	+0.2/-0.5

Table W: XTherm Blower Amp Draw—Reference Information

Model No.	Manifold Gas Pressure (High Fire Values)	
	Natural Gas	Propane Gas
1005	-1.1	-0.6
1505	-1.6	0.3
2005	-1.8	-2.0

Table X: XTherm Manifold Pressure Settings

CAUTION: Special manifold and air settings may be required.

Finishing

1. Record all data on the "Start-up Checklist" located at the back of this manual.
2. Disconnect the manometers and reconnect the cap on the fan pressure switch tee and reinsert the sealing screws into the bleedle valves.
3. Start-up is complete and the heater should be operating properly.

Safety Inspection

1. Check all thermostats and high limit settings.
2. During the following safety checks leave manometers hooked up, check and record.
3. If other gas-fired appliances in the room are on the same gas main, check all pressures on the XTherm with all other equipment running.
4. Check thermostats for ON-OFF operation.
5. Check high limits for ON-OFF operation.
6. While in operation, check flow switch operation.
7. Check the low gas pressure switch (if provided). (For proper adjustment, use the attached manometers, if available, to set pressure. The scales on the switch are approximate only.) Low gas pressure switch (if provided) must be set at 3.0 in. WC for natural gas and propane gas.
8. Make sure that the high gas pressure switch (optional) is set to 3.0 in. WC for both natural gas and propane gas.

Follow-Up

Safety checks must be recorded as performed. Turn heater on. After main burner ignition:

1. Check manometer for proper readings.
2. Cycle heater several times and re-check readings.
3. Remove all manometers and replace caps and screws.
4. Check for gas leaks one more time.

Leak Test Procedure: Dual-Seat Gas Valve

Proper leak testing requires three pressure test points in the gas train.

Remove the access panel on the rear of the heater to access the gas valve for this test. Test point A is a bleedle valve located upstream of the combination gas valve on the supply manifold.

NOTE: May have to remove HGPS (if applicable) to conduct this test.

Test point B is a bleedle valve located between the two automatic gas valve seats.

Test point C is a bleedle valve located downstream of both automatic gas valve seats and upstream of the manual valve. Refer to Fig. 54.

These tests are to be conducted with the electrical power to the heater turned OFF.

1. Manually close the downstream leak test valve.
2. Open the bleedle valve at test point A and connect a manometer to it. Verify that there is gas pressure and that it is within the proper range (NOTE: must not exceed 14.0 in. WC).
3. Open test point B and connect a rubber tube to it. Connect the other end of the tube to a manometer and look for a build-up of pressure. Increasing pressure indicates a leaking gas valve which must be replaced.
4. Next, close the upstream manual gas valve (field supplied) and remove the manometers from the bleedle valves in test point A and test point B. Connect a rubber tube from the test point A bleedle valve to the test point B bleedle valve.

dle valve to the test point B bleedle valve and open the upstream manual gas valve. Make sure that test point A & B bleedle valves have been opened so as to allow gas to flow. This will bring gas pressure to the second valve seat.

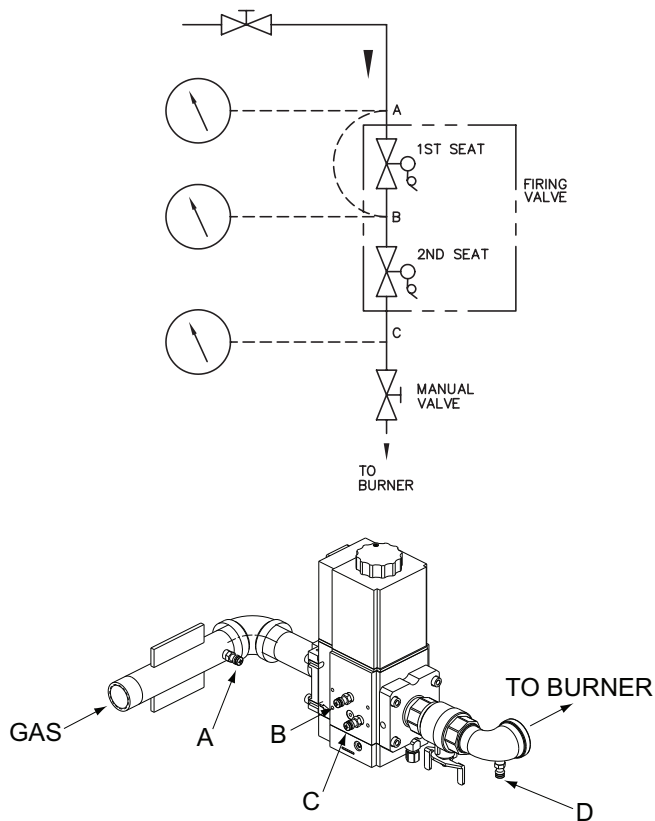

Fig. 54: Leak Test Procedure

5. Open the bleedle valve at test point C and connect a second rubber tube to it. Connect the other end of the tube to a manometer and look for a build-up of pressure. Increasing pressure indicates a leaking gas valve which must be replaced.
 6. Remove rubber tube and manometers. Close each test point bleedle valve as the tubes are removed.
- NOTE:** Reinstall HGPS as applicable.
7. After no leakage has been verified at all valve seats and test valves, open downstream leak test valve and restore electrical power to the heater.

Post Start-Up Check

Check off steps as completed:

1. Verify that the heater and heat distribution units or storage tank are filled with water.
2. Confirm that the automatic air vent (if used) was opened two full turns during the venting procedure.
3. Verify that air has been purged from the system.
4. Verify that air has been purged from the gas piping, and that the piping has been checked for leaks.
5. Confirm that the proper start-up procedures were followed.
6. Inspect burner to verify flame.
7. Test safety controls: If heater is equipped with a low water cut-off or additional safety controls, test for operation as outlined by manufacturer. Burner should be operating and should go off when controls are tested. When safety devices are restored, burners should re-ignite after pre-purge time delay.
8. Test limit control: While burner is operating, move indicator on high limit control below actual water temperature. Burner should go off while blower and circulator continue to operate. Raise setting on limit control above water temperature and burner should re-ignite after pre-purge time delay. **NOTE: Ignition control may have to be reset after this portion of the test.**
9. Test ignition system safety device:
 - a. Open manual gas valve. Turn power on.
 - b. Set thermostat to call for heat.
 - c. When the heater is in operation, pull cap off of tee in air switch hose. The burner should go off almost immediately.
 - d. Reattach cap on tee. Burner should re-ignite after pre-purge time delay. **NOTE: Ignition control may have to be reset after this portion of the test.**
10. To restart system, follow lighting instructions in the Operation section.

-
11. Check to see that the high limit control is set above the design temperature requirements of the system. For multiple zones: Check to make sure the flow is adjusted as required in each zone.
 12. Check that the heater is cycled with the thermostat. Raise the setting on the thermostat to the highest setting and verify that the heater goes through the normal start-up cycle. Reduce to the lowest setting and verify that the heater goes off.
 13. Observe several operating cycles for proper operation.
 14. Set the heater thermostat to desired temperature.
 15. Review all instructions shipped with this heater with owner or maintenance person, return to envelope and give to owner or place the instructions inside front panel on heater.

OPERATION

Lighting Instructions

1. Before lighting, make sure you have read all of the safety information in this manual.
2. Remove upper front panel.
3. Set the thermostat to the lowest setting.
4. Turn off all electrical power to the appliance.
5. This appliance is equipped with an ignition device which automatically lights the burner. Do not try to light the burner by hand.
6. Turn on main manual gas valve field installed near gas inlet connection on back of heater.
7. Wait 5 minutes to clear out any gas. Then smell for gas, especially near the floor. If you then smell gas, STOP! Follow the steps in the safety information on the front cover of this manual. If you do not smell gas, go to next step.
8. Turn on all electrical power to the appliance.
9. Set thermostat to desired setting. The appliance will operate. The igniter will glow after the pre-purge time delay (15 seconds). After igniter reaches temperature (30 seconds) the main valve should open. System will try for ignition up to three times (one time on optional single-try ignition module). If flame is not sensed, lockout will commence.

10. If the appliance will not operate, follow the instructions "To Turn Off Gas To Appliance," and call your service technician or gas supplier.
11. Replace upper front panel.
12. If heater fails to start, check the diagnostic board for troubleshooting information and verify the following:
 - a. There are no loose connections or that the service switch is off.
 - b. High temperature limit switch is set above water temperature or manual reset high limit is not tripped.
 - c. Thermostat is set above water temperature.
 - d. Gas is on at the meter and the heater.
 - e. Incoming dynamic gas pressure to the gas valve is NOT less than 4.0 in. WC for natural gas or propane gas.

To Turn Off Gas To Appliance

1. Shut off manual gas valve field installed near gas inlet connection on back of heater.
2. Remove upper front panel.
3. Set the thermostat to lowest setting.
4. Turn off all electrical power to the appliance if service is to be performed.
5. Replace access panel.

TROUBLESHOOTING

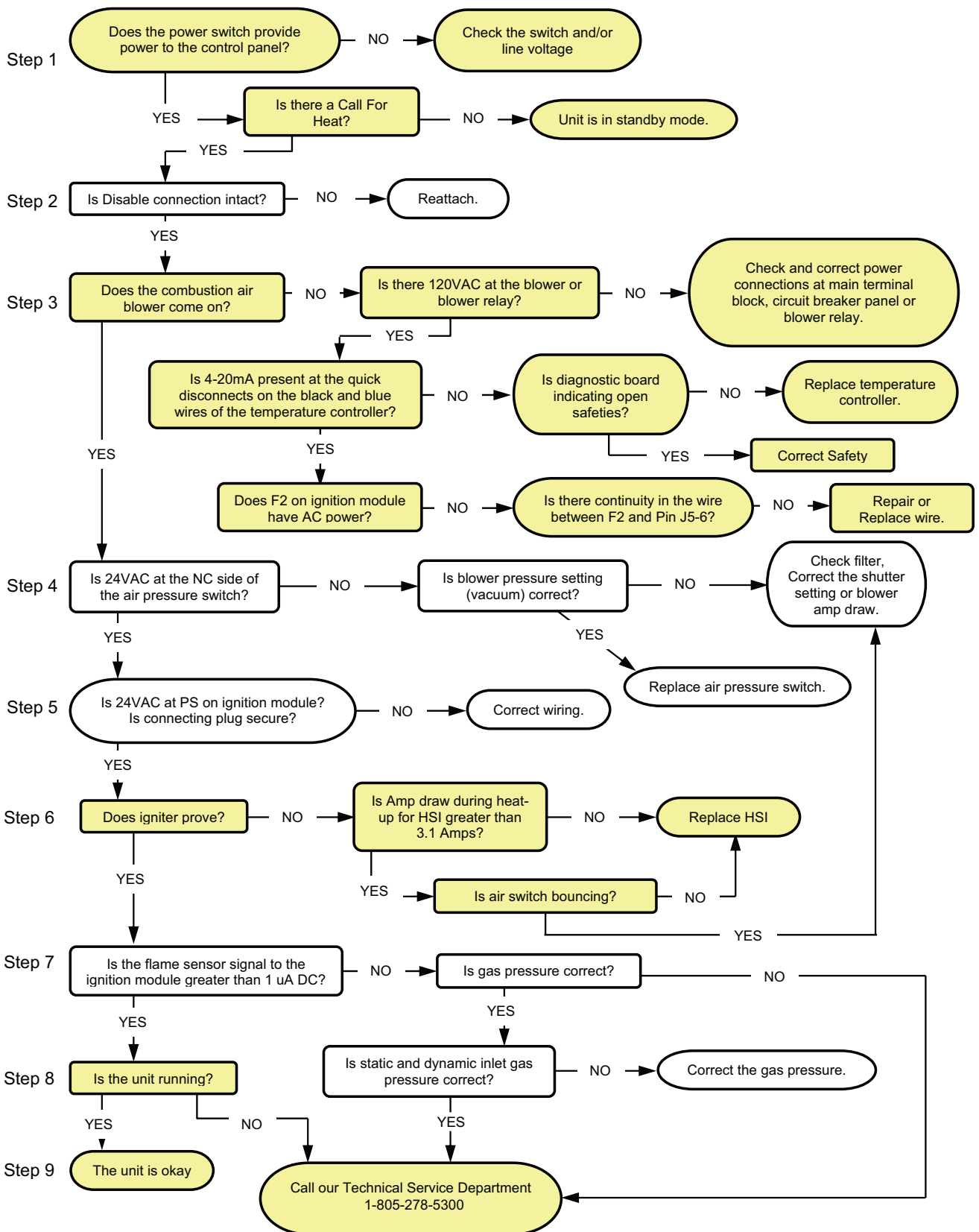

UDB Fault History

To view the fault codes in the UDB history file:

1. Press the **UP** or **DOWN** buttons on the membrane switch for 2 seconds to access the fault history.
2. Press either button to scroll through the recorded faults in history.
3. The most recent fault recorded will be the first fault displayed (the last 16 faults are stored in the history, on a rolling basis). There is no time or date stamp associated with these faults.
4. When the history of faults has been exhausted, pushing the **UP** or **DOWN** buttons again will roll the fault history over and it will start again.
5. To exit the fault history, wait for 10 seconds and the board will automatically exit the history mode.

To clear the fault history, press and hold **both** the **UP** and **DOWN** buttons for 5 seconds while the power is on.

NOTE: Once the history has been cleared, it cannot be recovered.

Diagnostic information is provided any time a fault is recorded. This information is intended to assist in locating the problem with the heater, but is not exhaustive.

If multiple fault conditions occur at the same time, only the fault that caused the heater to shut down will be recorded in the history.

MAINTENANCE

Suggested Minimum Maintenance Schedule

Regular service by a qualified service agency and maintenance must be performed to ensure maximum operating efficiency.

Maintenance as outlined below may be performed by the owner.

Daily

1. Check that the area where the heater is installed is free from combustible materials, gasoline, and other flammable vapors and liquids.
2. Check for and remove any obstruction to the flow of combustion or ventilation air to heater.

Monthly

1. Check for piping leaks around pumps, mixing valves, relief valves, and other fittings. If found, repair at once. DO NOT use petroleum-based stop-leak compounds.
2. Visually inspect burner flame.
3. Visually inspect venting system for proper function, deterioration or leakage.
4. Visually inspect for proper operation of the condensate drain in the venting and on the heater. If leaks are observed repair at once.
5. Check air vents for leakage.
6. Visually inspect air intake and filter for obstructions.
7. Check the fault history for potential issues and reset as necessary.

Yearly (Beginning Of Each Heating Season)

Schedule annual service call by qualified service agency.

1. Visually check top of vent for soot. Call service person to clean. Some sediment at bottom of vent is normal.

-
2. Visually inspect venting system for proper function, deterioration or leakage. Ensure that condensate drain is inspected and ensure that condensate is being directed to appropriate condensate management system or drain, as required by local codes.
 3. Check that area is free from combustible materials, gasoline, and other flammable vapors and liquids.
 4. Check for and remove any obstruction to the flow of combustion or ventilation air to heater.
 5. Follow pre-start-up check in the Start-up section.
 6. Visually inspect burner flame. It should be light blue at full input. Remove and visually inspect hot surface igniter and sensor for damage, cracking or debris build-up.
 7. Check operation of safety devices. Refer to manufacturers' instructions.
 8. Follow oil-lubricating instructions on pump (if required). Over-oiling will damage pump. Water-lubricated circulators do not need oiling.
 9. To avoid potential of severe burn, DO NOT REST HANDS ON OR GRASP PIPES. Use a light touch; return piping will heat up quickly.
 10. Check blower and blower motor
 11. Check for piping leaks around pumps, relief valves and other fittings. Repair, if found. DO NOT use petroleum-based stop-leak.
 12. Check the fault history and reset as necessary.

Periodically

1. Check relief valve(s). Refer to manufacturer's instructions on valve.
2. Test low water cut-off (if equipped). Refer to manufacturer's instructions.
3. Reset fault history after any testing.

Preventive Maintenance Schedule

The following procedures are recommended and are good practice for all XTherm installations.

Daily

1. Check gauges, monitors and indicators.
2. Check instrument and equipment settings. (See "Post Start-Up Check" on page 48.)
3. Check burner flame. (Should see light blue flame at full input rate).

Weekly

For low-pressure heaters, test low-water cut-off device. (With heater in pre-purge, depress the low water cut-off test button. Appliance should shut-off and ignition fault light should come on. Depress reset button on front of heater control panel to reset).

Monthly

1. Check flue, vent, stack, or outlet dampers.
2. Test blower air pressure. (See "Blower Check" on page 46.)
3. Test high and low gas pressure interlocks (if equipped). (See "Safety Inspection" on page 47.)
4. Check tracking pressure (see "Blower Check" step number 2 on page 46).
5. Reset fault history after any testing.

Semi-Annually

1. Recalibrate all indicating and recording gauges.
2. Check flame failure detection system components.
3. Check firing rate control by checking the manifold pressure. (See "Manifold Check" on page 46.)
4. Check piping and wiring of all interlocks and shut-off valves.

Annually

1. Test flame failure detection system and pilot turn-down.
2. Test high limit and operating temperature. (See "Post Start-Up Check," page 48.)
3. Check flame sensor.

4. Conduct a combustion test at full fire. Carbon dioxide should be 8.5 to 9.0% at full fire for natural gas, and between 9.5 to 10.0% for propane gas. Carbon monoxide should be < 100 ppm.
5. Check valve coil for 60 cycle hum or buzz. Check for leaks at all valve fittings using a soapy water solution (while heater is operating). Test other operating parts of all safety shut-off and control valves and increase or decrease settings (depending on the type of control) until the safety circuit opens. Reset to original setting after each device is tested.
6. Perform leakage test on gas valves (See Fig. 54).
7. Test air switch in accordance with manufacturer's instructions. (Turn panel switch to the "On" position until blower is proven, then turn the switch to "Off.")
8. Inspect and clean burner using shop air.
9. Reset fault history after any testing.

As Required

1. Recondition or replace low water cut-off device (if equipped).
2. Check drip leg and gas strainers.
3. Check flame failure detection system. (See "Post Start-Up Check," page 48.)
4. Check igniter. (Resistance reading should be 40-75 ohms at ambient temperature).
5. Check flame signal strength. (Flame signal should be greater than 1 **microampere** as measured at the 2 pins on the upper left corner of the ignition control).
6. Check firing rate control by checking the manifold pressure. (See "Manifold Check" on page 46.)
7. Test safety/safety relief valve(s) in accordance with ASME Heater and Pressure Vessel Code Section IV and Section VIII as applicable.

APPENDIX

Inside Air Contamination

All heaters experience some condensation during

start-up. The condensate from flue gas is acidic. Combustion air can be contaminated by certain vapors in the air which raise the acidity of the condensate. Higher acidity levels attack many materials including stainless steel, which is commonly used in high efficiency systems. The heater can be supplied with corrosion-resistant, non-metallic intake air vent material. You may, however, choose to use outside combustion air for one or more of these reasons:

1. Installation is in an area containing contaminants listed below which will induce acidic condensation.
2. You want to reduce infiltration into your building through openings around windows and doors.
3. You are using Category IV vent pipe as noted in Table L or Table M, which is more corrosion-resistant than standard metallic vent pipe. In extremely contaminated areas, this may also experience deterioration.

Products causing contaminated combustion air:

- spray cans containing chloro/fluorocarbons
- permanent wave solutions
- chlorinated waxes/cleaners
- chlorine-based swimming pool chemicals
- calcium chloride used for thawing
- sodium chloride used for water softening
- refrigerant leaks
- paint or varnish removers
- hydrochloric acid/muriatic acid
- cements and glues
- antistatic fabric softeners used in clothes dryers
- chloride-type bleaches, detergents, and cleaning solvents found in household laundry rooms
- adhesives used to fasten building products
- similar products

Areas where contaminated combustion air commonly exists:

- dry cleaning/laundry areas
- metal fabrication plants
- beauty shops
- refrigeration repair shops
- photo processing plants
- auto body shops
- plastic manufacturing plants
- furniture refinishing areas and establishments
- new building construction
- remodeling areas
- open pit skimmers

Check for areas and products listed above before installing heater. If found:

- remove products permanently, OR
- install TruSeal direct vent.

Important Instructions for the Commonwealth of Massachusetts

The Commonwealth of Massachusetts requires compliance with regulation 248 CMR 4.00 and 5.00 for installation of through – the – wall vented gas appliances as follows:

(a) For all side wall horizontally vented gas fueled equipment installed in every dwelling, building or structure used in whole or in part for residential purposes, including those owned or operated by the Commonwealth and where the side wall exhaust vent termination is less than seven (7) feet above finished grade in the area of the venting, including but not limited to decks and porches, the following requirements shall be satisfied:

1. **INSTALLATION OF CARBON MONOXIDE DETECTORS.** At the time of installation of the side wall horizontal vented gas fueled equipment, the installing plumber or gasfitter shall observe that a hard wired carbon monoxide detector with an alarm and battery back-up is installed on the floor level where the gas equipment is to be installed. In addition, the installing plumber or gasfitter shall observe that a battery operated or hard wired carbon monoxide detector with an alarm is installed on each additional level of the dwelling, building or structure served by the side wall horizontal vented gas fueled equipment. It shall be the responsibility of the property owner to secure the services of qualified licensed professionals for the installation of hard wired carbon monoxide detectors

a. In the event that the side wall horizontally vented gas fueled equipment is installed in a crawl space or an attic, the hard wired carbon monoxide detector with alarm and battery back-up may be installed on the next adjacent floor level.

b. In the event that the requirements of this subdivision can not be met at the time of completion of installation, the owner shall have a period of thirty (30) days to comply with the above requirements; provided, however, that during said thirty (30) day period, a battery operated carbon monoxide detector with an alarm shall be installed.

2. **APPROVED CARBON MONOXIDE DETECTORS.** Each carbon monoxide detector as required in accordance with the above provisions shall comply with NFPA 720 and be ANSI/UL 2034 listed and IAS certified.

3. **SIGNAGE.** A metal or plastic identification plate shall be permanently mounted to the exterior of the building at a minimum height of eight (8) feet above grade directly in line with the exhaust vent terminal for the horizontally vented gas fueled heating appliance or equipment. The sign shall read, in print size no less than one-half (1/2) inch in size, "GAS VENT DIRECTLY BELOW. KEEP CLEAR OF ALL OBSTRUCTIONS".

4. **INSPECTION.** The state or local gas inspector of the side wall horizontally vented gas fueled equipment shall not approve the installation unless, upon inspection, the inspector observes carbon monoxide detectors and signage installed in accordance with the provisions of 248 CMR 5.08(2)(a)1 through 4.

(b) **EXEMPTIONS:** The following equipment is exempt from 248 CMR 5.08(2)(a)1 through 4:

1. The equipment listed in Chapter 10 entitled "Equipment Not Required To Be Vented" in the most current edition of NFPA 54 as adopted by the Board; and

2. Product Approved side wall horizontally vented gas fueled equipment installed in a room or structure separate from the dwelling, building or structure used in whole or in part for residential purposes.

(c) **MANUFACTURER REQUIREMENTS - GAS EQUIPMENT VENTING SYSTEM PROVIDED.** When the manufacturer of Product Approved side wall horizontally vented gas equipment provides a venting system design or venting system components with the equipment, the instructions provided by the manufacturer for installation of the equipment and the venting system shall include:

1. Detailed instructions for the installation of the venting system design or the venting system components; and

2. A complete parts list for the venting system design or venting system.

(d) **MANUFACTURER REQUIREMENTS - GAS EQUIPMENT VENTING SYSTEM NOT PROVIDED.** When the manufacturer of a Product Approved side wall horizontally vented gas fueled equipment does not provide the parts for venting the flue gases, but identifies "special venting systems", the following requirements shall be satisfied by the manufacturer:

1. The referenced "special venting system" instructions shall be included with the appliance or equipment installation instructions; and

2. The "special venting systems" shall be Product Approved by the Board, and the instructions for that system shall include a parts list and detailed installation instructions.

(e) A copy of all installation instructions for all Product Approved side wall horizontally vented gas fueled equipment, all venting instructions, all parts lists for venting instructions, and/or all venting design instructions shall remain with the appliance or equipment at the completion of the installation.

GAS PRESSURE SUPERVISION

The Commonwealth of Massachusetts requires listed high and low gas pressure switches (manual reset) for any model with a maximum firing input greater than 1,000,000 Btu/Hr in accordance with 248 CMR 7.04(11)(d).

A gas pressure regulator (field supplied) is required in the gas train ahead of the heater, for heaters having input rates greater than 1,000,000 Btu/Hr, in accordance with 248 CMR 7.04 Figure 3B requirements.



**LIMITED PARTS WARRANTY
XTHERM – TYPES H AND WH
MODELS 1005-2005**

SCOPE

Raypak, Inc. ("Raypak") warrants to the original owner that all parts of this heater which are actually manufactured by Raypak will be free from failure under normal use and service for the specified warranty periods and subject to the conditions set forth in this Warranty. Labor charges and other costs for parts removal or reinstallation, shipping and transportation are not covered by this Warranty but are the owner's responsibility.

HEAT EXCHANGER WARRANTY

Domestic Hot Water

Five (5) years from date of heater installation. Includes copper heat exchanger with bronze waterways.

Ten (10) years from date of heater installation. Includes only cupro-nickel heat exchanger with bronze waterways.

Space Heating (Closed Loop System)

Ten (10) years from date of heater installation. Includes both cupro-nickel and copper heat exchanger with bronze waterways.

Thermal Shock Warranty

Twenty five (25) years from date of heater installation against "Thermal Shock" (excluded, however, if caused by heater operation at large changes exceeding 150°F between the water temperature at intake and heater temperature, or operating at heater temperatures exceeding 230°F).

Stainless Steel Condensing Heat Exchanger

Ten (10) years from date of heater installation.

ANY OTHER PART MANUFACTURED BY RAYPAK

One (1) year warranty from date of heater installation, or eighteen (18) months from date of factory shipment based on Raypak's records, whichever comes first.

SATISFACTORY PROOF OF INSTALLATION DATE, SUCH AS INSTALLER INVOICE, IS REQUIRED. THIS WARRANTY WILL BE VOID IF THE HEATER RATING PLATE IS ALTERED OR REMOVED.

ADDITIONAL WARRANTY EXCLUSIONS

This warranty does not cover failures or malfunctions resulting from:

1. Failure to properly install, operate or maintain the heater in accordance with our printed instructions provided;
2. Abuse, alteration, accident, fire, flood and the like;
3. Sediment or lime build-up, freezing, or other conditions causing inadequate water circulation;
4. High velocity flow exceeding heater design rates;
5. Failure of connected system devices, such as pump or controller;
6. Use of non-factory authorized accessories or other components in conjunction with the heater system;
7. Failing to eliminate air from, or replenish water in, the connected water system;
8. Chemical contamination of combustion air or use of chemical additives to water.

PARTS REPLACEMENT

Under this Warranty, Raypak will furnish a replacement for any failed part. The failed part must first be returned to Raypak if requested, with transportation charges prepaid, and all applicable warranty conditions found satisfied. The replacement part will be warranted for only the unexpired portion of the original warranty. Raypak makes no warranty whatsoever on parts not manufactured by it, but Raypak will apply any such warranty as may be provided to it by the parts manufacturer.

TO MAKE WARRANTY CLAIM

Promptly notify the original installer, supplying the model and serial numbers of the unit, date of installation and description of the problem. The installer must then notify his Raypak distributor for instructions regarding the claim. If either is not available, contact Service Manager, Raypak, Inc., 2151 Eastman Avenue, Oxnard, CA 93030 or call (805) 278-5300. In all cases proper authorization must first be received from Raypak before replacement of any part.

EXCLUSIVE WARRANTY - LIMITATION OF LIABILITY

This is the only warranty given by Raypak. No one is authorized to make any other warranties on Raypak's behalf. THIS WARRANTY IS IN LIEU OF ALL OTHER WARRANTIES, EXPRESS OR IMPLIED, INCLUDING BUT NOT LIMITED TO IMPLIED WARRANTIES OF MERCHANTABILITY AND FITNESS FOR A PARTICULAR PURPOSE. RAYPAK'S SOLE LIABILITY AND THE SOLE REMEDY AGAINST RAYPAK WITH RESPECT TO DEFECTIVE PARTS SHALL BE AS PROVIDED IN THIS WARRANTY. IT IS AGREED THAT RAYPAK SHALL HAVE NO LIABILITY, WHETHER UNDER THIS WARRANTY, OR IN CONTRACT, TORT, NEGLIGENCE OR OTHERWISE, FOR ANY SPECIAL, CONSEQUENTIAL, OR INCIDENTAL DAMAGE, INCLUDING DAMAGE FROM WATER LEAKAGE. Some states do not allow limitations on how long an implied warranty lasts, or for the exclusion of incidental or consequential damages. So the above limitation or exclusion may not apply to you.

This Limited Warranty gives you specific legal rights. You may also have other rights which may vary from state to state. We suggest that you complete the information below and retain this certificate in the event warranty service is needed. Reasonable proof of the effective date of the warranty (date of installation) must be presented, otherwise, the effective date will be based on the rate of manufacture plus thirty (30) days.

Original Owner _____	Model Number _____
Mailing Address _____	Serial Number _____
_____	Date of Installation _____
City _____ State _____ Zip Code _____	Installation Site _____
Daytime Telephone Number _____	Contractor/Installer _____



**LIMITED PARTS WARRANTY
X THERM – TYPES WHP AND P
MODELS 1005-2005**

SCOPE

Raypak, Inc. ("Raypak") warrants to the original owner that all parts of this heater which are actually manufactured by Raypak will be free from failure under normal use and service for the specified warranty periods and subject to the conditions set forth in this Warranty. Labor charges and other costs for parts removal or reinstallation, shipping and transportation are not covered by this Warranty but are the owner's responsibility.

HEAT EXCHANGER WARRANTY

Five (5) years from date of heater installation. Includes cupro-nickel heat exchanger with bronze waterways.

Thermal Shock Warranty

Twenty five (25) years from date of heater installation against "Thermal Shock" (excluded, however, if caused by heater operation at large changes exceeding 150°F between the water temperature at intake and heater temperature, or operating at heater temperatures exceeding 230°F).

Stainless Steel Condensing Heat Exchanger

Ten (10) years from date of heater installation.

ANY OTHER PART MANUFACTURED BY RAYPAK

One (1) year warranty from date of heater installation, or eighteen (18) months from date of factory shipment based on Raypak's records, whichever comes first.

SATISFACTORY PROOF OF INSTALLATION DATE, SUCH AS INSTALLER INVOICE, IS REQUIRED. THIS WARRANTY WILL BE VOID IF THE HEATER RATING PLATE IS ALTERED OR REMOVED.

ADDITIONAL WARRANTY EXCLUSIONS

This warranty does not cover failures or malfunctions resulting from:

1. Failure to properly install, operate or maintain the heater in accordance with our printed instructions provided;
2. Abuse, alteration, accident, fire, flood and the like;
3. Sediment or lime build-up, freezing, or other conditions causing inadequate water circulation;
4. High velocity flow exceeding heater design rates;
5. Failure of connected systems devices, such as pump or controller;
6. Use of non-factory authorized accessories or other components in conjunction with the heater system;
7. Chemical contamination of combustion air or use of chemical additives to water.
8. Misuse or neglect, including but not limited to freeze-ups, operating the heater with cabinet door off, having flow restrictions or obstructions between the heater outlet and pool/spa or not maintaining proper chemical balance (pH level must be between 7.2 and 7.8 and total alkalinity between 100 and 150 PPM. Total Dissolved Solids (TDS) must be no greater than 1500 PPM).

PARTS REPLACEMENT

Under this Warranty, Raypak will furnish a replacement for any failed part. The failed part must first be returned to Raypak if requested, with transportation charges prepaid, and all applicable warranty conditions found satisfied. The replacement part will be warranted for only the unexpired portion of the original warranty. Raypak makes no warranty whatsoever on parts not manufactured by it, but Raypak will apply any such warranty as may be provided to it by the parts manufacturer.

TO MAKE WARRANTY CLAIM

Promptly notify the original installer, supplying the model and serial numbers of the unit, date of installation and description of the problem. The installer must then notify his Raypak distributor for instructions regarding the claim. If either is not available, contact Service Manager, Raypak, Inc., 2151 Eastman Avenue, Oxnard, CA 93030 or call (805) 278-5300. In all cases proper authorization must first be received from Raypak before replacement of any part.

EXCLUSIVE WARRANTY - LIMITATION OF LIABILITY

This is the only warranty given by Raypak. No one is authorized to make any other warranties on Raypak's behalf. THIS WARRANTY IS IN LIEU OF ALL OTHER WARRANTIES, EXPRESS OR IMPLIED, INCLUDING BUT NOT LIMITED TO IMPLIED WARRANTIES OF MERCHANTABILITY AND FITNESS FOR A PARTICULAR PURPOSE. RAYPAK'S SOLE LIABILITY AND THE SOLE REMEDY AGAINST RAYPAK WITH RESPECT TO DEFECTIVE PARTS SHALL BE AS PROVIDED IN THIS WARRANTY. IT IS AGREED THAT RAYPAK SHALL HAVE NO LIABILITY, WHETHER UNDER THIS WARRANTY, OR IN CONTRACT, TORT, NEGLIGENCE OR OTHERWISE, FOR ANY SPECIAL, CONSEQUENTIAL, OR INCIDENTAL DAMAGE, INCLUDING DAMAGE FROM WATER LEAKAGE. Some states do not allow limitations on how long an implied warranty lasts, or for the exclusion of incidental or consequential damages. So the above limitation or exclusion may not apply to you.

This Limited Warranty gives you specific legal rights. You may also have other rights which may vary from state to state. We suggest that you complete the information below and retain this certificate in the event warranty service is needed. Reasonable proof of the effective date of the warranty (date of installation) must be presented, otherwise, the effective date will be based on the rate of manufacture plus thirty (30) days.

Original Owner _____			Model Number _____	
Mailing Address _____			Serial Number _____	
_____			Date of Installation _____	
City _____	State _____	Zip Code _____	Installation Site _____	
Daytime Telephone Number _____			Contractor/Installer _____	

START-UP CHECKLIST FOR FAN-ASSISTED RAYPAK PRODUCTS

This start-up checklist is to be completely filled out by the service technician starting up the Raypak Boiler or Heater for the first time. All information may be used for warranty purposes and to ensure that the installation is correct. Additionally this form will be used to record all equipment operation functions and required settings.

GAS SUPPLY DATA

Regulator Model & Size _____ / _____ CFH
 Gas Line Size (in room) _____ In. NPT
 Length of Gas Line _____ Eq Ft
 Low Gas Pressure Setting _____ In. WC
 High Gas Pressure Setting _____ In. WC
 Gas Shut-Off Valve Type _____
 (Ball, Lube cock)
 Sediment Trap _____ Y/N
 Port _____ Std _____ Full

VISUAL INSPECTION OF COMPONENTS

Verify inspection was done and condition of components are in good working order with a "yes"

Wiring Harness _____ Y/N
 Burner/s (flame) _____ Y/N
 Refractory (visual) _____ Y/N
 Remote flame sense _____ Y/N
 Covers in place for outdoor _____ Y/N

VENTING

Vent Size: _____ Stack Height: _____
 Category: _____ sketch vent on reverse side ***
 Vent Material: _____
 Vent Termination Type: _____
 Combustion Air Openings: Low _____ in2
 Ventilation air High _____ in2

EMISSIONS SETTINGS AND TEST INFORMATION (AT FULL FIRE)

Blower Pressure Setting _____ In. WC
 Supply Gas Pressure _____ In. WC
 Verify stable pressure static & dynamic condition
 Pilot Gas Pressure _____ In. WC
 Manifold Gas Pressure _____ In. WC
 Tracking Pressure (clean filter) _____ In. WC
 The following measurements must be obtained with a Combustion Analyzer.
 NOX _____ PPM
 Free Oxygen _____ %
 CO _____ PPM
 CO2 _____ %

CLEARANCES

Front Clearance _____ In.
 Right Side Clearance _____ In.
 Left Side Clearance _____ In.
 Rear Clearance _____ In.
 Overhead Clearance _____ In.

ELECTRICAL

Voltage Supply (VAC) No Load _____ Load _____
 Voltage -24 VAC _____ VAC
 Voltage Com to Ground _____ VAC
 Hot Surface Igniter _____ Ohms
 Auto High Limit Setting _____ deg F
 Manual Reset High Limit Setting _____ deg F
 Operating Control Setting _____ deg F

Sketch plumbing on reverse side

WATER SUPPLY

Flow Rate in GPM or Delta T _____ If Avail
 Measure flow rate at full fire
 Pump Economaster setting _____ Minutes
 Low Water Cutoff _____ Test
 Number of Tanks and Size Qty _____ Gallons
 Plumbing Size _____
 Pump Size: _____ (boiler) Pump HP: _____
 Impeller trim _____ Pump Model _____
 Louvers _____ Screens _____

Nominal Factory Recommended Settings

See manual or card tag
 See manual or card tag
 See manual or card tag
 See manual or card tag
 See manual
 See manual
 See manual

Model Number: _____

Serial Number: _____
 Site Altitude Above Sea Level _____ Ft.

*** Note: draw venting with details, such as extractors, barometric dampers, blast dampers or draft inducers

Job Name _____

Address _____

Physical Location of Boiler: Indoors _____; Outdoors _____; Ground Level _____; Roof _____; Below Grade _____

Mechanical Contractor / Installer _____

Date and Time of Start-up _____ Print Name and Signature of Start-up Technician _____

Information must be faxed to: (805) 278-5471 in order to ensure warranty consideration Attn: Service Manager



www.raypak.com

Raypak, Inc., 2151 Eastman Avenue, Oxnard, CA 93030 (805) 278-5300 Fax (805) 278-5468
Litho in U.S.A.