

APPROVED

# INSTALLATION AND OPERATION MANUAL



## XFIIRE MODELS

**BOILERS: H7 300B-1000B**

**WATER HEATERS: WH7 300B-1000B**

## IFIRE MODELS

**BOILERS: IBGWSF1 - 0300 TO 1000**

**WATER HEATERS: IVGWSF1 - 0300 TO 1000**



Boiler Only

**▲ WARNING:** Improper installation, adjustment, alteration, service, or maintenance can cause property damage, personal injury, exposure to hazardous materials\*, or loss of life. Review the information in this manual carefully. \*This unit contains materials that have been identified as carcinogenic, or possibly carcinogenic, to humans.

**FOR YOUR SAFETY:** Do not store or use gasoline or other flammable vapors and liquids or other combustible materials in the vicinity of this or any other appliance. To do so may result in an explosion or fire.

**WHAT TO DO IF YOU SMELL GAS:**

- Do not try to light any appliance.
- Do not touch any electrical switch; do not use any phone in your building.
- Immediately call your gas supplier from a neighbor's phone. Follow the gas supplier's instructions.
- If you cannot reach your gas supplier, call the fire department.

Installation and service must be performed by a qualified installer, service agency or the gas supplier.

This manual should be maintained in legible condition and kept adjacent to the heater or in a safe place for future reference.

Effective: 09-03-21  
Replaces: 05-05-21  
P/N 241941 Rev. 2

UNCONTROLLED DOCUMENT IF PRINTED

# APPROVED QUICK START GUIDE FOR BOILERS

## CLEARANCES

- Space required: see **page 10**.
- Minimum and service clearances: See **page 11** for clearances table. Note that local code prevails.

## COMBUSTION AIR

- Air filter location: See **page 13**.
- Ducting materials: PVC, CPVC, or sealed single-wall galvanized ducting, see **page 13** for details.

## PIPING

- Piping logic must be primary/secondary. Note that the heater should be located so that any water leaks will not cause damage to the adjacent area.
- Pressure relief valve: See **page 15** for recommended PRV orientation.
- Flow rates: See **page 17** for flow values table.
- Piping: See pages 18-20 for recommended configurations (including single heater and cascades).
- Tanks: All heaters should be equipped with a properly-sized expansion tank and air separator fitted at the highest point in the system.

## GAS

- Distance to regulator (pipe lengths) and gas inlet sizes: See **page 24**.
- Required pressure for natural gas:  
Min. = 4" WC, Max. = 10.5" WC
- Required pressure for propane:  
Min. = 8" WC, Max. = 13" WC
- Sediment trap is required for all installations.

## POWER

- Supply voltage: See **page 25** for input voltage table.

## VENTING - CAT IV

- Materials: PVC, CPVC, Polypropylene, stainless steel, see pages 30-34.
- Venting diagrams:  
For stainless steel and polypro, see pages 33-35.  
For PVC/CPVC, see pages 36-38.
- Outdoor venting:  
Outdoor Vent Kit. See **page 38**.

## CONTROLS INTERFACE

- User interface:  
VIEW menu is the default menu, see **page 48**.  
To change settings, use the SETUP/ADJUST menu, see **page 49**.
- Wiring diagram: See **page 55**.

## OPERATION

- Heater Status Light: See **page 61**.

Revision 2 reflects the following changes:

IPL: "S-2" Added "IFire" option (019041F); Added "4-J" SD Card WiFi Disabled IFire (019266F).

UNCONTROLLED DOCUMENT IF PRINTED

# APPROVED QUICK START GUIDE FOR WATER HEATERS

## CLEARANCES

- Space required: see **page 10**.
- Minimum and service clearances: See **page 11** for clearances table. Note that local code prevails.

## COMBUSTION AIR

- Air filter location: See **page 13**.
- Ducting materials: PVC, CPVC, or sealed single-wall galvanized ducting, see **page 13** for details.

## PIPING

- Piping logic must be primary/secondary. Note that the heater should be located so that any water leaks will not cause damage to the adjacent area.
- Pressure relief valve: See **page 15** for recommended PRV orientation.
- Flow rates: See **page 17** for flow values table.
- Piping: See pages 18-20 for recommended configurations (including single heater and cascades).
- Tanks: All heaters should be equipped with a properly-sized expansion tank and air separator fitted at the highest point in the system.

## GAS

- Distance to regulator (pipe lengths) and gas inlet sizes: See **page 24**.
- Required pressure for natural gas:  
Min. = 4" WC, Max. = 10.5" WC
- Required pressure for propane:  
Min. = 8" WC, Max. = 13" WC
- Sediment trap is required for all installations.

## POWER

- Supply voltage: See **page 25** for input voltage table.

## VENTING - CAT IV

- Materials: PVC, CPVC, Polypropylene, stainless steel, see pages 30-34.
- Venting diagrams:  
For stainless steel and polypro, see pages 33-35.  
For PVC/CPVC, see pages 36-38.
- Outdoor venting:  
Outdoor Vent Kit. See **page 38**.

## CONTROLS INTERFACE

- User interface:  
VIEW menu is the default menu, see **page 48**.  
To change settings, use the SETUP/ADJUST menu, see **page 49**.
- Wiring diagram: See **page 55**.

## OPERATION

- Heater Status Light: See **page 61**

# TABLE OF CONTENTS

|  |           |   |           |
|--|-----------|---|-----------|
| <b>1. WARNINGS</b> .....                             | <b>5</b>  | Common Venting .....                      | <b>39</b> |
| Pay Attention to These Terms .....                   | <b>5</b>  | Condensate Treatment .....                | <b>40</b> |
| <b>2. BEFORE INSTALLATION</b> .....                  | <b>6</b>  | Freeze Protection .....                   | <b>40</b> |
| Product Receipt .....                                | <b>6</b>  | <b>5. CONTROLS</b> .....                  | <b>41</b> |
| Model Identification .....                           | <b>6</b>  | Sequence of Operation .....               | <b>41</b> |
| Ratings and Certifications .....                     | <b>6</b>  | VERSA Integrated Control .....            | <b>42</b> |
| Installations at Elevation .....                     | <b>6</b>  | Glycol % Setting .....                    | <b>44</b> |
| Component Locations .....                            | <b>7</b>  | Vent Protection .....                     | <b>44</b> |
| <b>3. WATER TREATMENT</b> .....                      | <b>8</b>  | Control Devices .....                     | <b>45</b> |
| <b>4. INSTALLATION</b> .....                         | <b>9</b>  | User Interface .....                      | <b>48</b> |
| Installation Codes .....                             | <b>9</b>  | <b>6. WIRING DIAGRAM</b> .....            | <b>55</b> |
| Equipment Base .....                                 | <b>9</b>  | <b>7. START-UP</b> .....                  | <b>56</b> |
| Clearances.....                                      | <b>10</b> | Pre Start-up .....                        | <b>56</b> |
| Pallet Jack/Forklifting.....                         | <b>10</b> | Pre Start-up Check .....                  | <b>56</b> |
| Outdoor Installation.....                            | <b>12</b> | Initial Start-up.....                     | <b>56</b> |
| Combustion and Ventilation Air.....                  | <b>12</b> | Preparation .....                         | <b>56</b> |
| Inside Air Contamination.....                        | <b>12</b> | Start-Up .....                            | <b>57</b> |
| Air Supply .....                                     | <b>14</b> | <b>8. OPERATION</b> .....                 | <b>61</b> |
| Water Piping .....                                   | <b>15</b> | Lighting Instructions.....                | <b>61</b> |
| Hydronic Heating .....                               | <b>16</b> | To Turn Off Gas To Appliance .....        | <b>61</b> |
| Domestic Hot Water.....                              | <b>21</b> | Heater Status Light.....                  | <b>61</b> |
| Gas Supply .....                                     | <b>23</b> | <b>9. TROUBLESHOOTING</b> .....           | <b>61</b> |
| Gas Supply Connection.....                           | <b>23</b> | Heater Error Codes.....                   | <b>61</b> |
| Electrical Power Connections .....                   | <b>24</b> | Heater Errors .....                       | <b>61</b> |
| Multiple Voltage Configurations .....                | <b>26</b> | Heater Faults .....                       | <b>61</b> |
| Field Connected Devices.....                         | <b>26</b> | Raymote Troubleshooting (Optional).....   | <b>62</b> |
| Venting - General.....                               | <b>29</b> | Heater Fault Text .....                   | <b>62</b> |
| Vent Terminal Location .....                         | <b>31</b> | <b>10. MAINTENANCE</b> .....              | <b>64</b> |
| Venting Installation Tips.....                       | <b>32</b> | Suggested Minimum                         |           |
| Venting Configurations.....                          | <b>32</b> | Maintenance Schedule .....                | <b>64</b> |
| Stainless Steel and Polypropylene - Vertical Venting |           | Preventive Maintenance Schedule .....     | <b>65</b> |
| (Category IV) .....                                  | <b>32</b> | Air Filter Maintenance.....               | <b>66</b> |
| Stainless Steel and Polypropylene - Direct Vent-     |           | <b>11. ILLUSTRATED PARTS LIST</b> .....   | <b>67</b> |
| Vertical .....                                       | <b>34</b> | <b>12. IMPORTANT INSTRUCTIONS FOR THE</b> |           |
| Stainless Steel and Polypropylene - Horizontal       |           | <b>COMMONWEALTH OF MASSACHUSETTS</b> ...  | <b>73</b> |
| Through-the-Wall and Direct Vent - Horizontal ....   | <b>35</b> | <b>13. START-UP CHECKLIST</b> .....       | <b>74</b> |
| PVC/CPVC - Vertical Venting (Cat IV).....            | <b>36</b> | <b>14. WARRANTY</b> .....                 | <b>75</b> |
| PVC/CPVC - Direct Vent - Vertical.....               | <b>36</b> |   |           |
| PVC/CPVC - Horizontal Through-the-Wall and Direct    |           |   |           |
| Vent - Horizontal .....                              | <b>37</b> |   |           |
| Outdoor Installation.....                            | <b>38</b> |   |           |

**NOTE: Patent-pending features utilized in heater construction and operation.**

**UNCONTROLLED DOCUMENT IF PRINTED**



# 1. WARNINGS

## Pay Attention to These Terms

|                  |   |
|------------------|---|
| <b>▲ DANGER</b>  | Indicates the presence of immediate hazards which will cause severe personal injury, death or substantial property damage if ignored.                                       |
| <b>▲ WARNING</b> | Indicates the presence of hazards or unsafe practices which could cause severe personal injury, death or substantial property damage if ignored.                            |
| <b>▲ CAUTION</b> | Indicates the presence of hazards or unsafe practices which could cause minor personal injury or product or property damage if ignored.                                     |
| <b>CAUTION</b>   | CAUTION used without the warning alert symbol indicates a potentially hazardous condition which could cause minor personal injury or product or property damage if ignored. |
| <b>NOTE</b>      | Indicates special instructions on installation, operation, or maintenance which are important but not related to personal injury hazards.                                   |

**▲ DANGER:** Make sure the gas on which the heater will operate is the same type as that specified on the heater rating plate.

**▲ WARNING:** Risk of electrical shock. More than one disconnect switch may be required to de-energize the equipment before servicing.

**▲ WARNING:** Heaters using propane gas are different from natural gas models. A natural gas heater will not function safely on propane and vice versa. Conversions of heater gas type should only be made by qualified installers using factory supplied components. The heater should only use the fuel type in accordance with listing on rating plate. Any other fuel usage will result in death or serious personal injury from fire and/or explosion.

**NOTE:** Minimum pipe size for the heater inlet/outlet connections is dependent on the equivalent length of piping between the load loop and the heater loop, the operating conditions and the size of the heater. See Table M and Table L.

**▲ WARNING:** Should overheating occur or the gas supply valve fail to shut, do not turn off or disconnect the electrical supply to the heater. Instead, shut off the gas supply at a location external to the heater.

**▲ WARNING:** Both natural gas and propane have an odorant added to aid in detecting a gas leak. Some people may not physically be able to smell or recognize this odorant. If you are unsure or unfamiliar with the smell of natural gas or propane, ask your local gas supplier. Other conditions, such as “odorant fade,” which causes the odorant to diminish in intensity, can also hide, camouflage, or otherwise make detecting a gas leak by smell more difficult.

**▲ WARNING:** Do not use this heater if any part has been under water. Immediately call a qualified service technician to inspect the heater and to replace any part of the control system and any gas control which has been under water.

**▲ CAUTION:** If this heater is to be installed in a negative or positive pressure equipment room, there are special installation requirements. Consult factory for details.

**▲ WARNING:** To minimize the possibility of improper operation, serious personal injury, fire, or damage to the heater:

- Always keep the area around the heater free of combustible materials, gasoline, and other flammable liquids and vapors.
- Heater should never be covered or have any blockage to the flow of fresh air to the heater.

**▲ CAUTION:** This heater requires forced water circulation when the burner is operating. See Table M and Table L for flow rate information. Severe damage will occur if the heater is operated without proper water flow circulation.

## 2. BEFORE INSTALLATION

## Ratings and Certifications

We strongly recommend that this manual be reviewed thoroughly before installing your heater. Please review the General Safety information before installing the heater. Factory warranty does not apply to heaters that have been improperly installed or operated. Refer to the warranty at the back of this manual.

Installation and service must be performed by a qualified installer, service agency, or gas supplier. If, after reviewing this manual, you still have questions which this manual does not answer, please contact our local representative.

**NOTE: We recommend laying out and installing the vent system before installing water piping. This will ensure that the venting system and associated components will fit into the attached space for proper operation.**

### Product Receipt

On receipt of your heater it is suggested that you visually check for external damage to the shipping crate. If the crate is damaged, make a note to that effect on the Bill of Lading when signing for the shipment. Next, remove the heater from the shipping packaging. Report any damage to the carrier immediately. On occasion, items are shipped loose. Be sure that you receive the correct number of packages as indicated on the Bill of Lading.

Claims for shortages and damages must be filed with the carrier by consignee. Permission to return goods must be received from the factory prior to shipping. Goods returned to the factory without an authorized Returned Goods Receipt number will not be accepted. All returned goods are subject to a restocking charge.

When ordering parts, you must specify the model and serial number of the heater. When ordering under warranty conditions, you must also specify the date of installation.

Purchased parts are subject to replacement only under the manufacturer's warranty. Debits for defective replacement parts will not be accepted. Parts will be replaced in kind only per our standard warranties.

### Model Identification

The model identification number and heater serial number are found on the rating plate located on the rear jacket panel of the heater. See **Figure 3**.

The model number will have the form H7-1000 or similar depending on the heater size and configuration.

### Standards

- ANSI Z21.13 · CSA 4.9 - latest edition, Gas-Fired Hot Boilers
- CSA 2.17 - latest edition, Gas-Fired Appliances for Use at High Altitudes
- ANSI Z21.10.3 CSA 4.3- latest edition, Gas Water Heater
- CAN 3.1 - latest edition, Industrial, Low-lead and Commercial Gas-Fired Package Heaters
- SCAQMD Rule 1146.2
- Low-lead content (<.25%) CSA-certified

All units are National Board registered, and design-certified and tested by the Canadian Standards Association (CSA) for the U.S. and Canada. Each heater is constructed in accordance with Section IV of the American Society of Mechanical Engineers (ASME) Heater Pressure Vessel Code and bears the ASME "H" stamp. This heater also complies with the latest edition of the ASHRAE 90.1 Standard.

**⚠ WARNING: Altering any factory pressure vessel by installing replacement heat exchangers, or any ASME parts not manufactured and/or approved by the factory will instantly void the ASME and CSA ratings of the vessel and any manufacturer warranty on the vessel. Altering the ASME or CSA ratings of the vessel also violates national, state, and local approval codes.**

### Installations at Elevation

Rated inputs are suitable for up to 4,500 ft (1,372 m) elevation. Consult your local representative or the factory for installations at altitudes over 4,500 ft (1,372 m) above sea level.

### General Information

| Heater Size | Input MBTUH (KW) |              | Vent Size in. (mm) |         | Water Inlet/Outlet NPT in. (mm) | Gas Connection NPT in. (mm) |
|-------------|------------------|--------------|--------------------|---------|---------------------------------|-----------------------------|
|             | Max              | Min          | Flue               | Intake  |                                 |                             |
| 300         | 300 (88)         | 42.8 (12.5)  | 4 (100)            | 4 (100) | 2 (50)                          | 1 (25)                      |
| 400         | 399 (117)        | 57.1 (16.7)  | 4 (100)            | 4 (100) | 2 (50)                          | 1 (25)                      |
| 500         | 500 (147)        | 71.4 (20.9)  | 4 (100)            | 4 (100) | 2 (50)                          | 1 (25)                      |
| 650         | 650 (190)        | 92.8 (27.2)  | 6 (150)            | 6 (150) | 2 (50)                          | 1-1/4 (32)                  |
| 800         | 800 (234)        | 114.2 (33.5) | 6 (150)            | 6 (150) | 2 (50)                          | 1-1/4 (32)                  |
| 1000        | 1000 (293)       | 142.8 (41.9) | 6 (150)            | 6 (150) | 2.5 (65)                        | 1-1/4 (32)                  |

Table A. Basic Product Data

# Component Locations

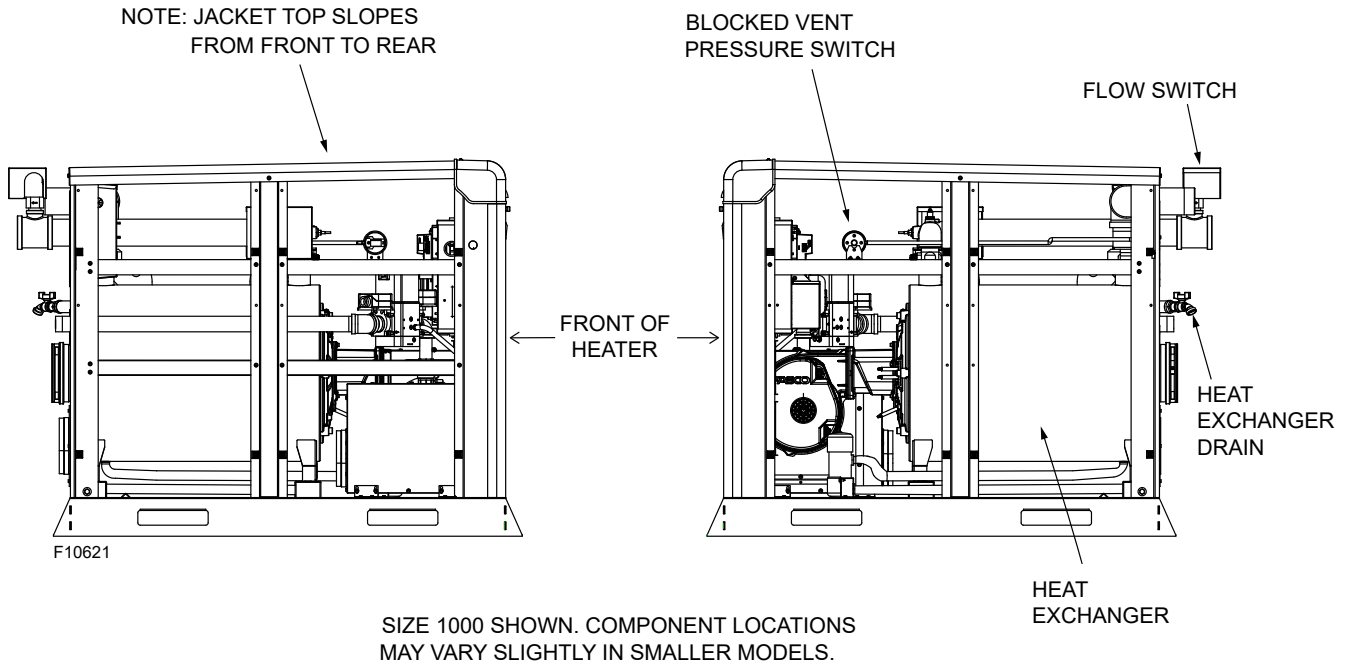

Figure 1. Component Locations – Side View

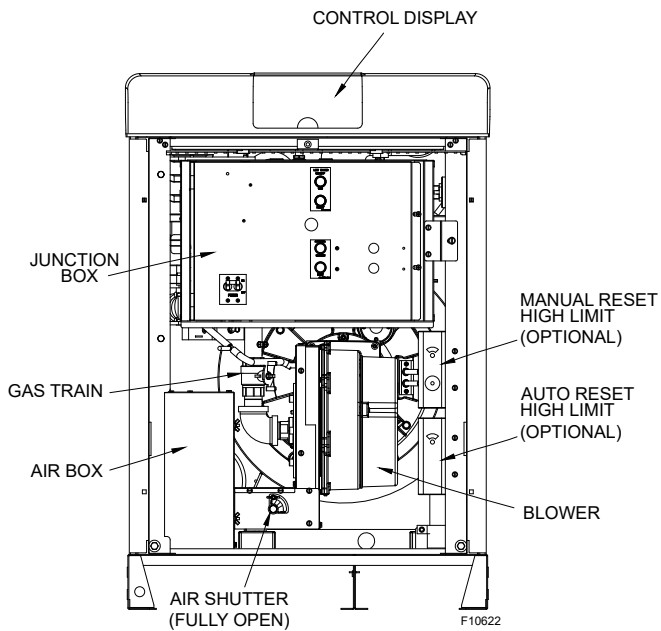

Figure 2. Component Locations - Front View

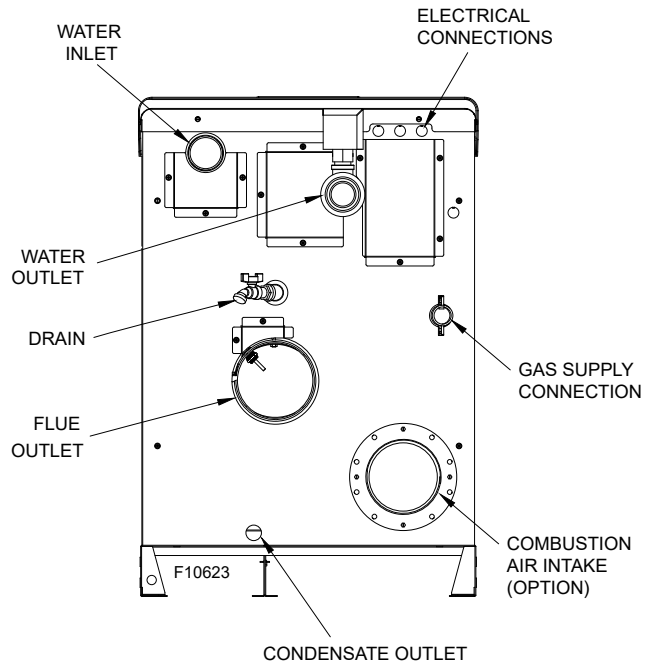
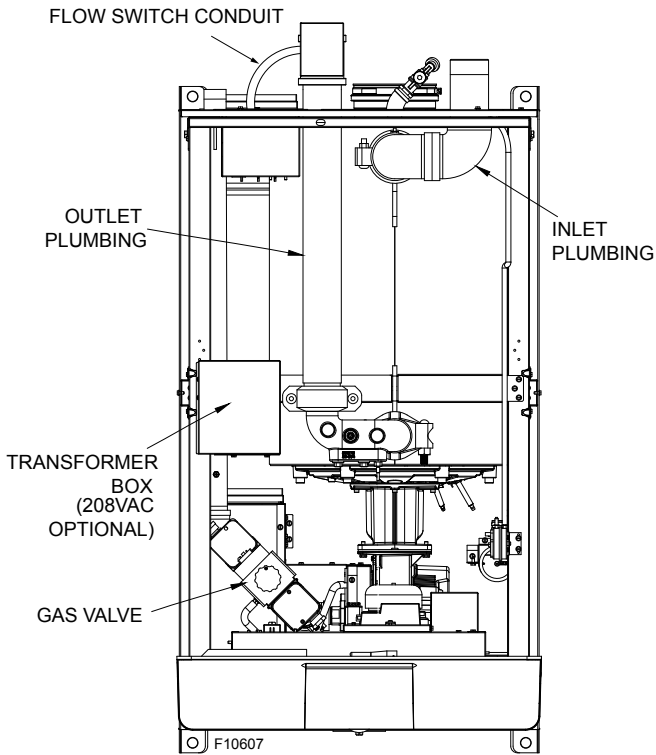

Figure 3. Component Locations - Rear View

**APPROVED**



**Figure 4. Component Locations - Top View**

### 3. WATER TREATMENT

Before and during assembly, the system must be kept free of impurities, construction dust, sand, copper dust, grease, carbon deposits, etc., as well as welding flux residue. In any of these instances, the old system must be rinsed with clear water mixed with a highly concentrated rinse agent.

More generally, it is advised to implement any procedure necessary to prevent or treat contamination.

Black oxide sludge (magnetite- $Fe_3O_4$ ) forms as a result of continuous electrolytic corrosion in any system unprotected by an inhibitor. Iron oxide ( $Fe_2O_3$ ) (red oxide sludge) is produced during oxygenation. Scale deposit is made up of lime scale contained in most distributed water that settles over the warmest surfaces of the system. Sludge and scale do mix together and are the cause of the main encountered field problems on heating installations.

The presence of these substances means that standard precautions are not implemented. In this case, product warranty cannot be applied.

The chemical compatibility of several products for the treatment of heating water equipment has been tested on heat exchangers.

Manufacturer recommends the using of these corrosion inhibitors in preventive and curative treatment for boilers.

**⚠ CAUTION:** When water hardness is higher than 15 GPG, a softener **MUST** be used. Failure to do so can cause scale build up and failure of the heat exchanger not covered by warranty.

| Producers         | Fernox                  | Sentinel   | Sotin     | ADEY |
|-------------------|-------------------------|------------|-----------|------|
| Inhibitors        | Protector F1 / Alphi 11 | X100, X500 | Sotin 212 | MC1+ |
| Noise Reducer     |                         | X200       |           |      |
| Universal Cleaner | Restorer                | X300       |           |      |
| Sludge Remover    | Protector F1 Cleaner F3 | X400       | Sotin 212 |      |
| Antifreeze        | Alphi 11                | X500       |           |      |

**Table B. Corrosion/Scale Inhibitors and Recommended Suppliers**

| Treatment Type | Preventative | Curative |
|----------------|--------------|----------|
| Protector F1   | X            |          |
| Cleaner F3     | X            | X        |
| X100           | X            |          |
| X200           | X            |          |
| X300           |              | X        |
| X400           |              | X        |
| X500           | X            |          |
| Alphi 11       | X            |          |
| Sotin 212      |              | X        |
| MC1+           | X            |          |

**Table C. Treatment Type**

| Water Chemistry                     | Boiler                       |
|-------------------------------------|------------------------------|
| Water Temperature                   | 41°F to 212°F (5°C to 100°C) |
| pH (system contains aluminum parts) | 7.5-8.5                      |
| pH (without aluminum parts)         | 7.5-9.5                      |
| Total Dissolved Solids (GPG)        | 3-9                          |

**Table D. Boiler Water Chemistry**

| Heater Size | Flow (GPM) at Water Hardness 4-12 GPG | Flow (GPM) at Water Hardness 12-15 GPG* | pH      |
|-------------|---------------------------------------|---|---------|
| 300         | 27.3                                  | 36.7                                    | 6.0-8.5 |
| 400         | 27.3                                  | 36.7                                    |         |
| 500         | 32.8                                  | 44                                      |         |
| 650         | 43.7                                  | 58.6                                    |         |
| 800         | 54.6                                  | 73.3                                    |         |
| 1000        | 65.5                                  | 88.0                                    |         |

**Table E. Water Heater Minimum Flow Rate**

\* When water hardness is higher than 15 GPG, a softener shall be used. Water hardness values for calcium carbonate.

# 4. INSTALLATION

## Installation Codes

Installations must follow these codes:

- Local, state, provincial, and national codes, laws, regulations and ordinances
- National Fuel Gas Code, ANSI Z223.1/NFPA 54 – latest edition (NFGC)
- National Electrical Code, ANSI/NFPA 70 - latest edition (NEC)
- Standard for Controls and Safety Devices for Automatically Fired Heaters, ANSI/ASME CSD-1, (CSD-1) when required
- For Canada only: CAN/CSA B149.1 Natural Gas and Propane Installation Code and CSA C22.1 C.E.C. Part 1 (C22.1)

## Equipment Base

The heater should be mounted on a level, structurally sound surface. Local code may require housekeeping pad. The heater is approved for installation on a combustible surface but must NEVER be installed on carpeting. Gas-fueled equipment installed in enclosed parking garages must be located at least 18" (457 mm) above the floor.

**CAUTION:** This heater should be located in an area where water leakage will not result in damage to the area adjacent to the appliances or to the structure.

In addition, the heater shall be installed such that the gas ignition system components are protected from water (dripping, spraying, rain, etc.) during appliance operation or service (circulator replacement, control replacement, etc.).

If the heater needs to be secured to the ground, use the hole pattern shown in **Figure 5** and **Figure 6**, following local codes.

**NOTE:** Multi-Unit Mounting - To install units side-by-side, use the optional mounting brackets and hardware (Option Code: Z-13).

| Heater Size | A<br>in. (mm) |
|-------------|---------------|
| 300 - 500   | 35.33 (897)   |
| 600 - 800   | 43.75 (1111)  |
| 1000        | 48.50 (1232)  |

Table F. Anchor Hole Dimensions

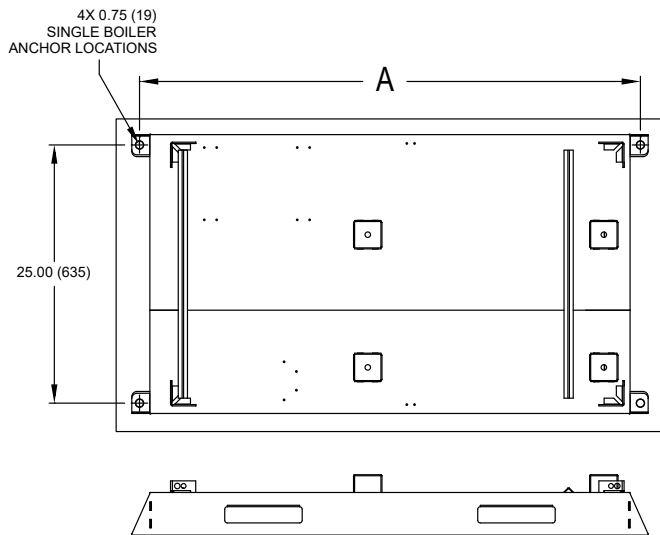

Figure 5. Single-Unit Anchor Hole Locations

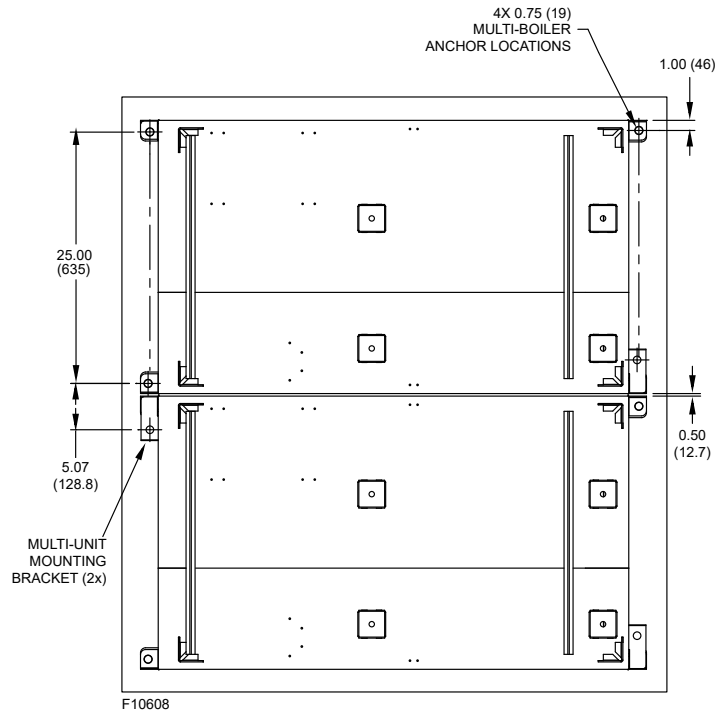

Figure 6. Multiple-Unit Anchor Hole Locations

# Clearances

## Indoor Installations

| Heater Side | Minimum Clearances from Combustible Surfaces in. (mm) | Minimum Service Clearance in. (mm) |
|-------------|---|------------------------------------|
| Floor *     | 0   | 0                                  |
| Rear        | 24 (610)  | 24 (610)                           |
| Right Side  | 0   | 0                                  |
| Left Side   | 0   | 0                                  |
| Top         | 0   | 0                                  |
| Front       | Open  | 30 (762)                           |
| Vent        | 1 (25)  | 1 (25)                             |

\* DO NOT install on carpeting

Table G. Clearances - Indoor Installations

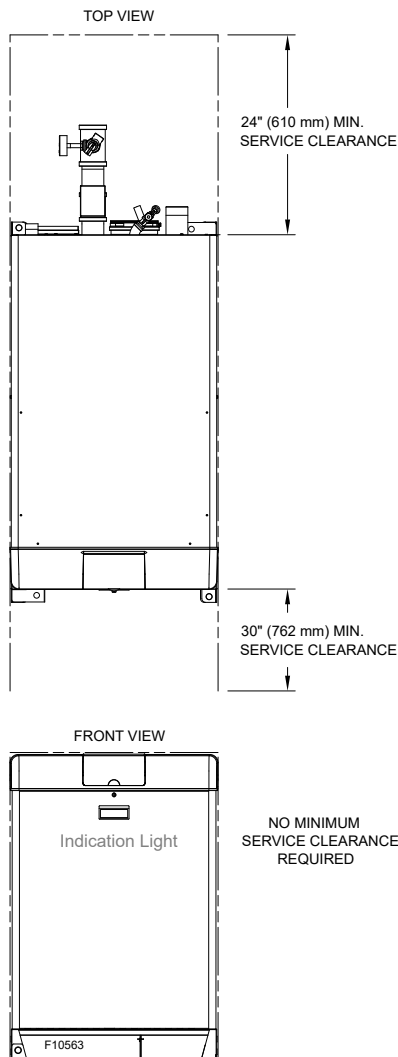

Figure 7. Minimum Clearances from Combustible Surfaces – Indoor and Outdoor Installations

## APPROVED

For ease of servicing, a clearance of at least 30" (762 mm) in front, at least 24" (610 mm) on the rear. This will allow the heater to be serviced in its installed location without movement or removal of the heater.

Service clearances less than the minimum may require removal of the heater to service either the heat exchanger or the burner components. In either case, the heater must be installed in a manner that will enable the heater to be serviced without removing any structure around the heater.

## Pallet Jack/Forklifting

These heaters are designed to be moved by pallet jack or forklift (front side or either side).

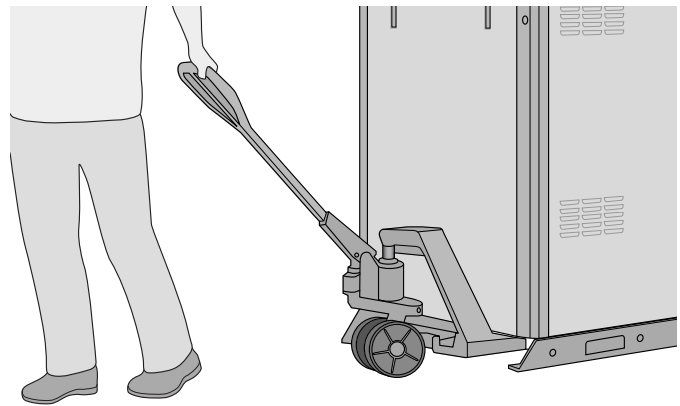

Figure 8. Pallet Jack

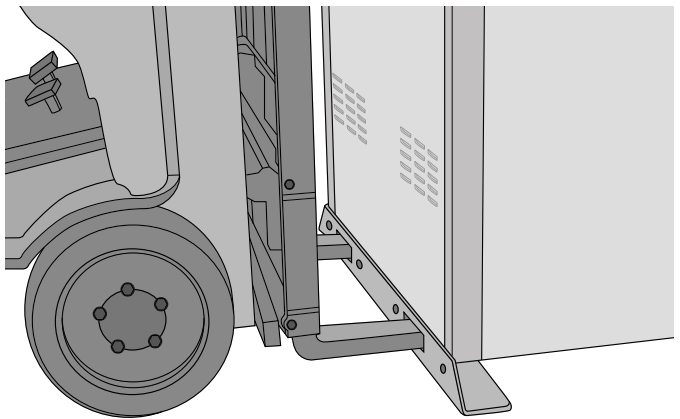
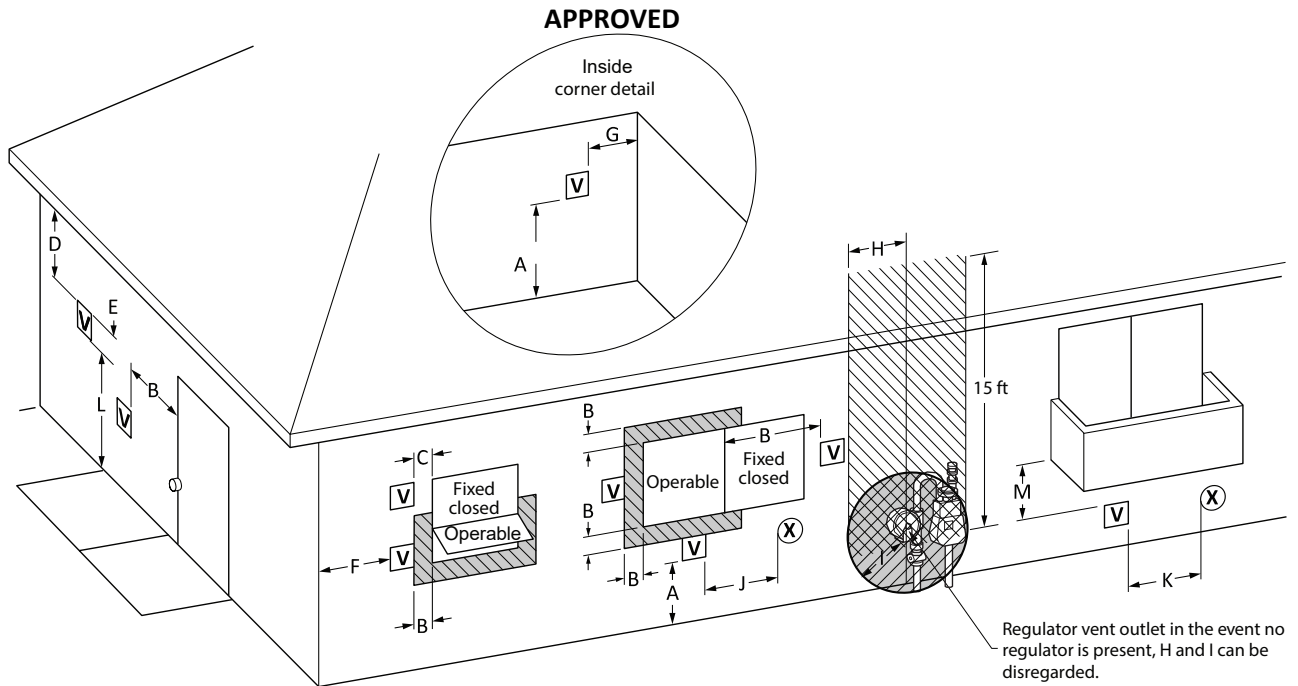

Figure 9. Forklifting



**Figure 10. Minimum Clearances from Vent/Air Inlet Terminations – Indoor and Outdoor Installations**

|   |   | U.S. Installations <sup>1</sup>                                  | Canadian Installations <sup>2</sup>                               |
|---|---|--|---|
| A | Clearance above grade, veranda, porch, deck, or balcony   | 1' (30 cm)   | 1' (30 cm)  |
| B | Clearance to window or door that may be opened  | 4' (1.2 m) below or to side of opening                           | 3' (91 cm)  |
| C | Clearance to permanently closed window  | *  | *   |
| D | Vertical clearance to ventilated soffit located above the terminal within a horizontal distance of 2' (61 cm) from the centerline of the terminal | 5' (1.5 m)   | *   |
| E | Clearance to unventilated soffit  | *  | *   |
| F | Clearance to outside corner   | *  | *   |
| G | Clearance to inside corner  | 6' (1.83 m)  | *   |
| H | Clearance to each side of center line extended above meter/regulator assembly   | *  | 3' (91 cm) within a height 15' above the meter/regulator assembly |
| I | Clearance to service regulator vent outlet  | *  | 6' (1.83 m)   |
| J | Clearance to non-mechanical air supply inlet to building or the combustion air inlet to any other appliance                                       | 4' (1.2 m) below or to side of opening; 1' (30 cm) above opening | 3' (91 cm)  |
| K | Clearance to mechanical air supply inlet  | 3' (91 cm) above if within 10' (3 m) horizontally                | 6' (1.83 m)   |
| L | Do not terminate above paved sidewalk or paved driveway   | +  | N/A   |
| M | Clearance under veranda, porch, deck or balcony   | *  | 12" (30 cm) <sup>†</sup>  |

<sup>1</sup> In accordance with the current ANSI Z223.1/NFPA 54 National Fuel Gas Code.

<sup>2</sup> In accordance with the current CAN/CSA-B149.1 Installation Codes.

<sup>†</sup> Permitted only if veranda, porch, deck, or balcony is fully open on a minimum of two sides beneath the floor and top of terminal, and underside of veranda, porch, deck or balcony is greater than 1' (30 cm).

\* Clearances in accordance with local installation codes and the requirements of the gas supplier.

+ 7' (2.13 m) for mechanical draft systems (Category I appliances); vents for Category II and IV appliances cannot be located above public walkways or other areas where condensate or vapor can cause a nuisance or hazard.

**Table H. Vent/Air Inlet Termination Clearances**  
**UNCONTROLLED DOCUMENT IF PRINTED**



**APPROVED**

**Outdoor Installation**

**CAUTION:** DO NOT install heater outdoors in freezing climates.

**NOTE:** Housekeeping pad of adequate height required for outdoor units to protect heater from standing water.

These units may be installed outdoors when provided with the factory-supplied and required outdoor trim.

Heaters must not be installed under an overhang unless clearances are in accordance with local installation codes and the requirements of the gas supplier.

Three sides must be open in the area under the overhang. Roof water drainage must be diverted away from heaters installed under overhangs.

Combustion air is drawn through the louvers in the jacket. DO NOT remove the cap as shipped from the factory.

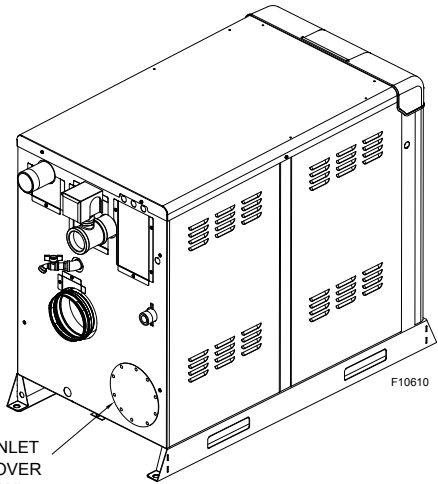

Figure 11. Outdoor Combustion Air

**CAUTION:** Do not install where the condensate can freeze. Take appropriate measures.

| Heater Side      | Minimum Clearances from Combustible Surfaces in. (mm) | Minimum Service Clearance in. (mm) |
|------------------|---|------------------------------------|
| Rear             | 24 (610)  | 24 (610)                           |
| Front            | Open  | 30 (762)                           |
| Left Side        | 0   | 0                                  |
| Right Side       | 0   | 0                                  |
| Top              | 0   | 0                                  |
| Vent Termination | Open  | Open                               |

Table I. Clearances – Outdoor Installations

**NOTE:** Vent termination must not terminate under less than 3 ft (1 m) below eaves, soffits or overhangs.

**Combustion and Ventilation Air**

**NOTE:** Use of this heater in construction areas where fine particulate matter, such as concrete or dry-wall dust, is present may result in damage to the heater that is not covered by the warranty. If operated in a construction environment, a clean source of combustion air must be provided directly to the heater.

**Inside Air Contamination**

All heaters experience some condensation during start-up. The condensate from flue gas is acidic. Combustion air can be contaminated by certain vapors in the air which raise the acidity of the condensate. Higher acidity levels attack many materials including stainless steel, which is commonly used in high efficiency systems. The heater can be supplied with corrosion-resistant, non-metallic intake air vent material. You may, however, choose to use outside combustion air for one or more of these reasons:

1. Installation is in an area containing contaminants listed below which will induce acidic condensation.
2. You want to reduce infiltration into your building through openings around windows and doors.
3. You are using AL29-4C stainless steel, PVC, CPVC or Polypropylene vent pipe, which is more corrosion-resistant than standard metallic vent pipe. In extremely contaminated areas, this may also experience deterioration.

Products causing contaminated combustion air:

- spray cans containing chloro/fluorocarbons
- permanent wave solutions
- chlorinated waxes/cleaners
- chlorine-based swimming pool chemicals
- calcium chloride used for thawing
- sodium chloride used for water softening
- refrigerant leaks
- paint or varnish removers
- hydrochloric acid/muriatic acid
- cements and glues
- antistatic fabric softeners used in clothes dryers
- chloride-type bleaches, detergents, and cleaning solvents found in household laundry rooms
- adhesives used to fasten building products
- similar products



## APPROVED

Areas where contaminated combustion air commonly exists:

- dry cleaning/laundry areas
- metal fabrication plants
- beauty shops
- refrigeration repair shops
- photo processing plants
- auto body shops
- plastic manufacturing plants
- furniture refinishing areas and establishments
- new building construction
- remodeling areas
- open pit skimmers

Check for areas and products listed above before installing heater. If found:

- remove products permanently, OR
- install Direct Vent/Truseal™ option

### Indoor Units

This heater must be supplied with sufficient quantities of non-contaminated air to support proper combustion and equipment ventilation. Combustion air can be supplied via conventional means where combustion air is drawn from the area immediately surrounding the heater, (as shipped from factory, combustion air is drawn through louvers in jacket panels) or via direct vent, where combustion air is drawn directly from outside. All installations must comply with the requirements of the NFGC (U.S.) and B149.1 (Canada), and all local codes.

**CAUTION:** Combustion air must not be contaminated by corrosive chemical fumes which can damage the heater and cause a non-warrantable failure.

**NOTE:** It is recommended that the intake vent be insulated to minimize sweating in freezing climates.

### Air Filter

An air filter is supplied standard with the heater. All models use a 12" x 12" MERV 8 filter. Remove front panel and access panel to filter to inspect and/or replace the air filter. See **Figure 12**.

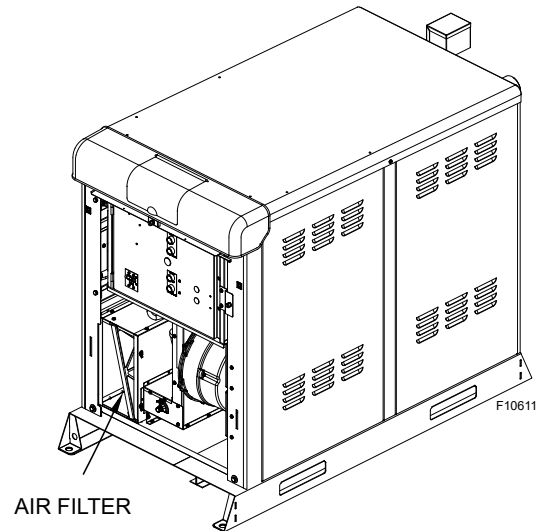

**Figure 12. Air Filter Location**

### Direct Vent/Truseal™ Option / Accessory

Combustion air may be ducted directly to the heater using PVC, CPVC, or sealed single-wall galvanized ducting. The resulting installation meets the requirements for a direct-vent installation. See venting section for detailed information. Install the TruSeal air intake connection to provide an anchor point for the combustion air duct.

1. Install combustion air duct to the Air Intake Connection. See **Figure 33, Figure 35, Figure 38, and Figure 40**. Remove and discard the outdoor cap and extend the combustion air duct through the top to connection to combustion air duct. Seal the joint and fasteners with RTV (not supplied). All ducting shall be self-supporting.
2. In cold climates, and to mitigate potential freeze-up, we highly recommend the installation of a motorized sealed damper to prevent the circulation of cold air through the heater during non-operating hours. The Motorized Combustion Air Damper (sales order option D-37) meets these needs.
3. Ventilation of the room occupied by the heater(s) is required and can be provided by an opening(s) for ventilation air within 12" (305 mm) of the highest practical point communicating with the outdoors. The total cross-sectional area of these openings shall be at least 1 square inch free air space per 20,000 BTUH (111 mm<sup>2</sup> per kW) of total input rating of all equipment in the room, when the opening is communicating directly with the outdoors or through vertical duct(s). The total cross-sectional area shall be at least 1 square inch of net free air space per 10,000 BTUH (222 mm<sup>2</sup> per kW) of total input rating of all equipment in the room, when the opening is communicating with the outdoors through horizontal duct(s). Damage to the equipment due to inadequate ventilation of the space is not a warrantable failure.

## APPROVED

### Motorized Combustion Air Dampers or Louvers

When motorized dampers or louvers are used for combustion air, they must be interlocked with each appliance in the equipment room, to ensure proper operation.

See Field Wiring Connection section of this manual for proper wiring instructions, using Fan/Damper dry contacts and external interlock.

**⚠ WARNING:** When unit is installed in the freezing climates using ducted combustion air, a motorized damper must be used and must be interlocked with the heater per NFGC requirements.

**⚠ CAUTION:** All ducting must be self-supported.

## Air Supply

### U.S. Installations

#### All Air from Inside the Building

The confined space shall be provided with TWO permanent openings communicating directly with an additional room(s) of sufficient volume so that the combined volume of all spaces meets the criteria for a room large in comparison (NFGC). The total input of all gas utilization equipment installed in the combined space shall be considered in making this determination. Each opening shall have a minimum free area of 1 square inch per 1,000 BTUH (2,225 mm<sup>2</sup> per kW) of the total input rating of all gas utilization equipment in the confined space, but not less than 100 square inches (645 cm<sup>2</sup>). One opening shall commence within 12" (305 mm) of the top, and one opening shall commence within 12" (305 mm) of the bottom of the enclosure. The minimum dimension of air openings shall be not less than 3" (76 mm) in any direction.

#### All Air from Outdoors

The confined space shall communicate with the outdoors in accordance with one of the methods below. The minimum dimension of air openings shall not be less than 3" (76 mm) in any direction. Where ducts are used, they shall be of the same cross-sectional area as the net free area of the openings to which they connect.

1. **Two permanent openings**, one commencing within 12" (305 mm) of the top, and one commencing within 12" (305 mm) of the bottom of the enclosure, shall be provided. The openings shall communicate directly, or by ducts, with the outdoors or spaces (crawl or attic) that freely communicate with the outdoors.

- a. Where directly communicating with the outdoors or where communicating to the outdoors through vertical ducts, **each opening** shall have a minimum free area of 1 square inch per 4,000 BTUH (550 mm<sup>2</sup> per kW) of total input rating of all equipment in the enclosure.

- b. Where communicating with the outdoors through horizontal ducts, **each opening** shall have a minimum free area of 1 square inch per 2,000 BTUH (1,100 mm<sup>2</sup> per kW) of total input rating of all equipment in the enclosure.

2. **One permanent opening**, commencing within 12" (305 mm) of the top of the enclosure, shall be permitted where the equipment has clearances of at least 1" (25.4 mm) from the sides and back and 6" (152 mm) from the front of the appliance. The opening shall directly communicate with the outdoors or shall communicate through a vertical or horizontal duct to the outdoors or spaces that freely communicate with the outdoors, and shall have a minimum free area of:

- a. 1 square inch per 3,000 BTUH (740 mm<sup>2</sup> per kW) of the total input rating of all equipment located in the enclosure, and

- b. Not less than the sum of the areas of all vent connectors in the confined space.

**⚠ WARNING:** Do not use the "one permanent opening" method if the equipment room is under negative-pressure conditions.

### Canadian Installations

**⚠ CAUTION:** All combustion air must be drawn from the air outside of the building; the mechanical equipment room must communicate directly with the outdoors.

Ventilation of the space occupied by the heater shall be provided by an opening(s) for ventilation air at the highest practical point communicating with the outdoors. The total cross-sectional area of such an opening(s) shall be at least 10% of the area required below, but in no case shall the cross-sectional area be less than 10 square inches (65 cm<sup>2</sup>).

**⚠ WARNING:** Make sure that the equipment room is not under negative-pressure conditions.

When air supply is provided by natural air flow from outdoors for a power burner and there is no draft regulator, draffhood or similar flue gas dilution device installed in the same space, in addition to the opening for ventilation air required above, there shall be a permanent air supply opening(s) having a total cross-sectional area of not less than 1 square inch for each 30,000 BTUH (74 mm<sup>2</sup> per kW) of total rated input of the burner(s), and the location of the opening(s) shall not interfere with the intended purpose of the opening(s) for ventilation air referred above.

UNCONTROLLED DOCUMENT IF PRINTED

**APPROVED**

This opening(s) can be ducted to a point not more than 18" (450 mm) nor less than 6" (152 mm) above the floor level. The duct can also "goose neck" through the roof. The duct is preferred to be straight down 18" (450 mm) from the floor, but not near piping. Refer to the B149.1 Installation Code for additional information.

## Water Piping

### General

The heater should be located so that any water leaks will not cause damage to the adjacent area or structures.

**NOTE:** Minimum pipe size for the heater inlet/outlet connections is dependent on the equivalent length of piping between the load loop and the heater loop, the operating conditions and the size of the heater. See Table M and Table L.

### Relief Valve Piping

**WARNING:** Pressure relief valve discharge piping must be piped near the floor and close to a drain to eliminate the potential of severe burns. Do not pipe to any area where freezing could occur. Refer to local codes.

The pressure relief valve (PRV) is shipped loose in the Shipped Loose Items carton inside the crating.

All PRVs are shipped loose to protect them from damage during shipping/rigging into place.

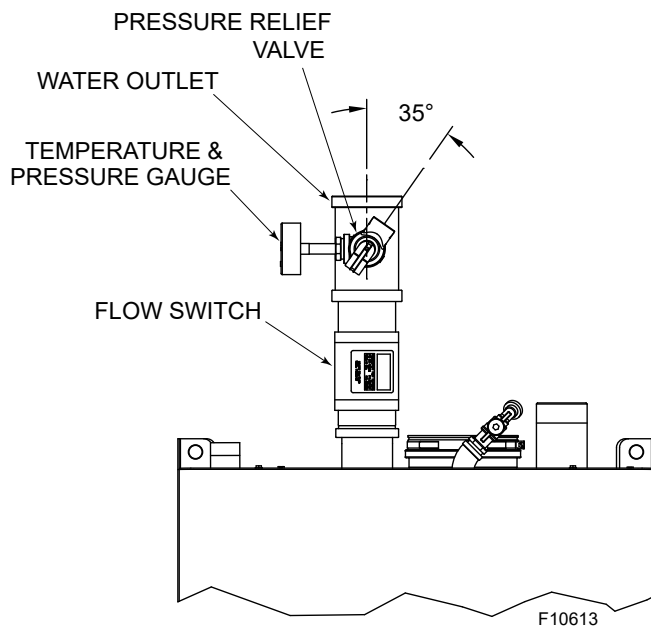

Figure 13. Recommended PRV Orientation

## Temperature and Pressure Gauge

The temperature and pressure gauge is shipped loose.

## Hydrostatic Test

Unlike many types of heaters, this heater does not require hydrostatic testing prior to being placed in operation. The heat exchanger has already been factory-tested and is rated for 160 psi (1100 kPa) operating pressure. However, manufacturer does recommend hydrostatic testing of the piping connections to the heater and the rest of the system prior to operation. This is particularly true for hydronic systems using expensive glycol-based anti-freeze. Manufacturer recommends conducting the hydrostatic test before connecting gas piping or electrical supply. Leaks must be repaired at once to prevent damage to the heater. NEVER use petroleum-based stop-leak compounds.

Isolate heater water connections from the system prior to performing a hydrostatic test.

## Flushing/Cleaning of System Piping

Many of the chemicals used to perform this function will harm the heat exchanger as well as some of the gaskets and seals within the unit, causing a non-warrantable failure. When required, manufacturer recommends the heater be isolated from the system piping prior to flushing or cleaning, using any cleaning agent.

## System Sensor Installation

The System Sensor (S3) is required for all cascade or primary/secondary piping configurations unless the units firing rate will be controlled by an external source such as our Temp Tracker MOD+ Hybrid sequencer. Proper placement and method of installation are critical for proper operation of the system.

The sensor must be installed in a drywell in conjunction with heat conductive compound as shown in Figure 14. The drywell must be installed no more than 5 equivalent feet (1.52 m) of pipe/tubing downstream of the de-coupler and installed in such a way that ensures the sensor bulb is in the flow path on primary/secondary configurations or 5 equivalent feet (1.52 m) downstream of the last heater in Primary Cascade systems.

**CAUTION:** Be careful when installing the drywell not to over-tighten the well as this can damage the well and may prevent the sensor from fitting properly.

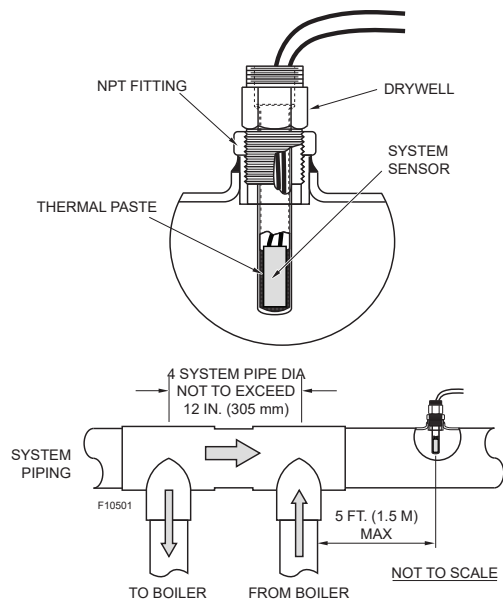

Figure 14. System Sensor Installation on Primary/Secondary Systems

## Hydronic Heating

### Pump Selection

**NOTE:** We support primary/secondary piping on this product. We do not support primary piping on this product.

In order to ensure Proper performance of your heater system, you must install a correctly-sized pump. We recommend designing for a  $\Delta T$  with the range of 15°F to 35°F (8°C to 19°C). See for acceptable flow rates for each model ( $\Delta T$  is the temperature difference between the inlet and outlet water when the heater is firing at the full rate).

Our standard pump selection for boiler models is based on 30°F (17°C)  $\Delta T$ , and allows for up to 100 equivalent feet (30 m) of tubing between the boiler and the system connections.

**NOTE:** Higher return temperatures may limit the firing rate when the maximum water temperature of 200°F (93°C) is approached.

The standard boiler pump selection is shown below.

| Heater Size | Standard Boiler Pump |                 |     |              |            |                    |
|-------------|----------------------|-----------------|-----|--------------|------------|--------------------|
|             | TACO MDL             | GRUNDFOS MODEL# | HP  | AMPS @120VAC | GPM/ FT HD | $\Delta T$ °F (°C) |
| 300         | 0012                 | 95906630        | 1/8 | 1.3          | 30@8.5'    | 19 (11)            |
| 400         | 0012                 | 95906630        | 1/8 | 1.3          | 30@8.5'    | 26 (14)            |
| 500         | 0012                 | 95906630        | 1/8 | 1.3          | 32@7.8'    | 30 (17)            |
| 650         | 1611                 | 97523134        | 1/8 | 5.7          | 55@14'     | 23 (13)            |
| 800         | 1611                 | 97523134        | 1/8 | 5.7          | 57@13'     | 27 (15)            |
| 1000        | 1611                 | 97523134        | 1/4 | 5.7          | 65@9.8'    | 30 (16)            |

Table J. Standard H7 Boiler Pump (Fixed Speed)

## APPROVED

**NOTE:** For systems using glycol, see Table K below for necessary pumping requirements.

| Parameter Correction       | Ethylene Glycol Concentration (%) |       |       |       |       |
|----------------------------|-----------------------------------|-------|-------|-------|-------|
|                            | 0                                 | 25    | 30    | 40    | 50    |
| Capacity Factor Multiplier | 1.000                             | 0.972 | 0.960 | 0.928 | 0.878 |
| GPM Correction Multiplier  | 1.000                             | 1.040 | 1.055 | 1.100 | 1.150 |

See Glycol section on page 44.

Table K. Glycol Correction Factors (Requires Optional Flow Meter)

## Feedwater Regulator

Manufacturer recommends that a feedwater regulator be installed and set at 12 psi (8.3 kPa) minimum pressure at the highest point of the system. Install a check valve or back flow device upstream of the regulator, with a manual shut-off valve as required by local codes.

## Piping

All high points should be vented. This heater, when used in connection with a refrigeration system, must be installed so that the chilled medium is piped in parallel with the heater with appropriate valves to prevent the chilled medium from entering the heater. The piping system of a hot water heater connected to heating coils located in air-handling units where they may be exposed to circulating refrigerated air, must be equipped with flow-control valves or other automatic means to prevent gravity circulation of the heater water during the cooling cycle. It is highly recommended that the piping be insulated.

## Air-Separation/Expansion Tank

All heaters should be equipped with a properly-sized expansion tank and air separator fitted at the highest point in system.

## Primary/Secondary Piping - Boiler Models Only

**NOTE:** All hot water heating systems have unique levels of operating diversity that must be accounted for in the system design. The system should always include adequate system flow in excess of the connected heater flow for proper operation of the primary/secondary system. Where the system flow may drop below the connected heater flow a buffer/decoupler may be needed. Failure to design for adequate flow (i.e. bypasses, 3-way control valves, flow-limiting balance devices, buffer tanks, etc.) will result in heater short-cycling and may reduce heater life. Always contact your local manufacturer representative for system design assistance to avoid these issues.



**APPROVED**

| Boiler Size | MBTUH (kW/h) |            | 20°F ΔT     |                | 30°F ΔT     |                | Min Flow <sup>1</sup> |                |            | Max Flow <sup>2</sup> |                |            |
|-------------|--------------|------------|-------------|----------------|-------------|----------------|-----------------------|----------------|------------|-----------------------|----------------|------------|
|             | Input        | Output     | GPM (L/min) | ΔP ft.wc.(kPa) | GPM (L/min) | ΔP ft.wc.(kPa) | GPM (L/min)           | ΔP ft.wc.(kPa) | ΔT °F (°C) | GPM (L/min)           | ΔP ft.wc.(kPa) | ΔT °F (°C) |
| 300         | 300 (88)     | 289.5 (84) | 29 (110)    | 6 (18)         | 19 (72)     | 3 (9)          | 15 (56)               | 2 (6)          | 39 (22)    | 38 (144)              | 10 (30)        | 15 (8)     |
| 400         | 399 (117)    | 383 (112)  | 38 (144)    | 11 (33)        | 26 (97)     | 5 (15)         | 20 (74)               | 3 (9)          | 39 (22)    | 50 (189)              | 17 (51)        | 15 (8)     |
| 500         | 500 (147)    | 480 (141)  | 48 (182)    | 12 (36)        | 32 (121)    | 6 (18)         | 25 (93)               | 4 (12)         | 39 (22)    | 62 (235)              | 20 (60)        | 15 (8)     |
| 650         | 650 (191)    | 624 (183)  | 62 (235)    | 11 (33)        | 42 (158)    | 5 (15)         | 32 (121)              | 3 (9)          | 39 (22)    | 80 (303)              | 17 (51)        | 16 (9)     |
| 800         | 800 (235)    | 768 (225)  | 77 (291)    | 12 (36)        | 51 (194)    | 6 (18)         | 39 (149)              | 4 (12)         | 39 (22)    | 90 (341)              | 16 (48)        | 17 (9)     |
| 1000        | 1000 (294)   | 960 (281)  | 96 (363)    | 14 (42)        | 64 (242)    | 6 (18)         | 49 (186)              | 4 (12)         | 39 (22)    | 90 (341)              | 12 (36)        | 21 (12)    |

Pipe sizing based on not exceeding 8 feet per second velocity.

ΔP = Feet of Head.

Max flow may require larger than 3 inch piping to not exceed max velocity.

<sup>1</sup> Minimum flow based on H<sub>2</sub>O as heating media. Media other than H<sub>2</sub>O may require higher minimum flow rates.

<sup>2</sup> Maximum flow based on 15°F (8°C) ΔT or 8 feet per second (2.4 m per second) velocity, whichever is less.

**Table L. Boiler Rates of Flow for Various System Pipe Sizes**

### Applications and Modes - Primary/Secondary Piping

The VERSA IC<sup>®</sup> control system is designed for a wide range of applications. The installer/design engineer should refer to the following Modes to determine which best fits the intended application and functionality for the unit being installed.

Boiler models have three modes available to them to address the various applications the units can be applied to. For detailed information on the VERSA IC<sup>®</sup> system, see the VERSA IC<sup>®</sup> Manual (241493).

**CAUTION:** When water hardness is higher than 15 GPG, a softener must be Used. Failure to do so can cause scale build up and failure of the heat exchanger not covered by warranty.

#### Mode 1

This mode selection is for hydronic heating systems with single or multiple heaters (refer to VERSA IC<sup>®</sup> Manual [241493] for detailed Cascade operation) in primary/secondary piping configuration with or without Outdoor Air Reset (S4). See **Figure 15** and **Figure 16**. (Illustrations shows 4 boilers for reference only.)

The system temperature is controlled by the System Sensor (S3). The Heater Pump (P1) runs during any call-for-heat. The System Pump (P2) runs whenever the system is enabled for heating and the outdoor air temperature is lower than the warm weather shut down (WWSD) temperature setting (if utilized).

The Heater Pump (P1) is delayed "Off" as user-defined in the Heater menu and the System Pump (P2) is delayed "Off" in the ADJUST menu.

**NOTE:** In cascade configuration, the system pump and DHW pump (if applicable) outputs from each cascade member must be connected in parallel to activate the system pump and DHW pump during "limp-along" operation respectively. See VERSA IC<sup>®</sup> Manual (241493) for detailed information.

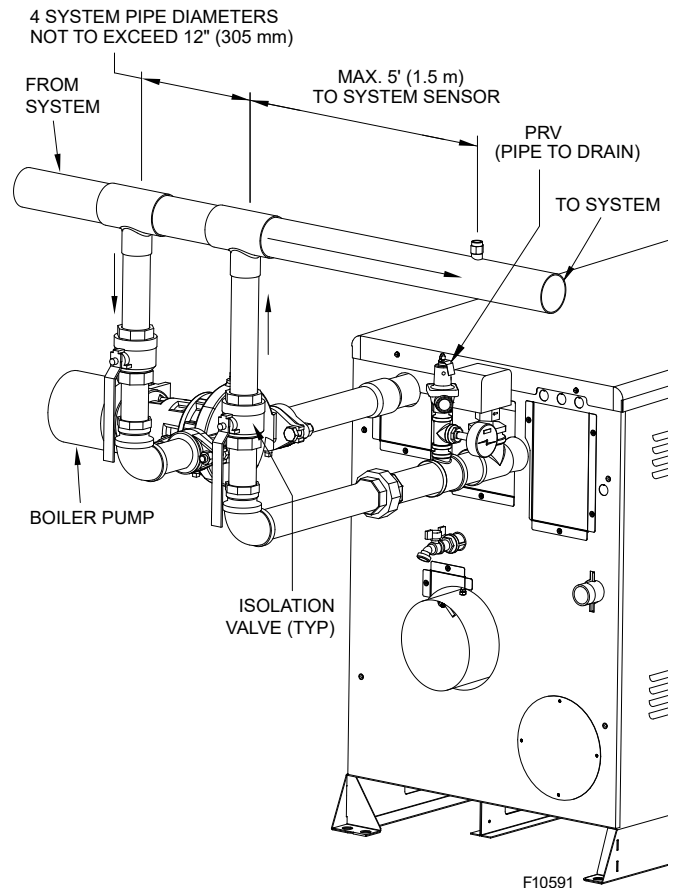

**Figure 15. Hydronic Primary/Secondary Piping**

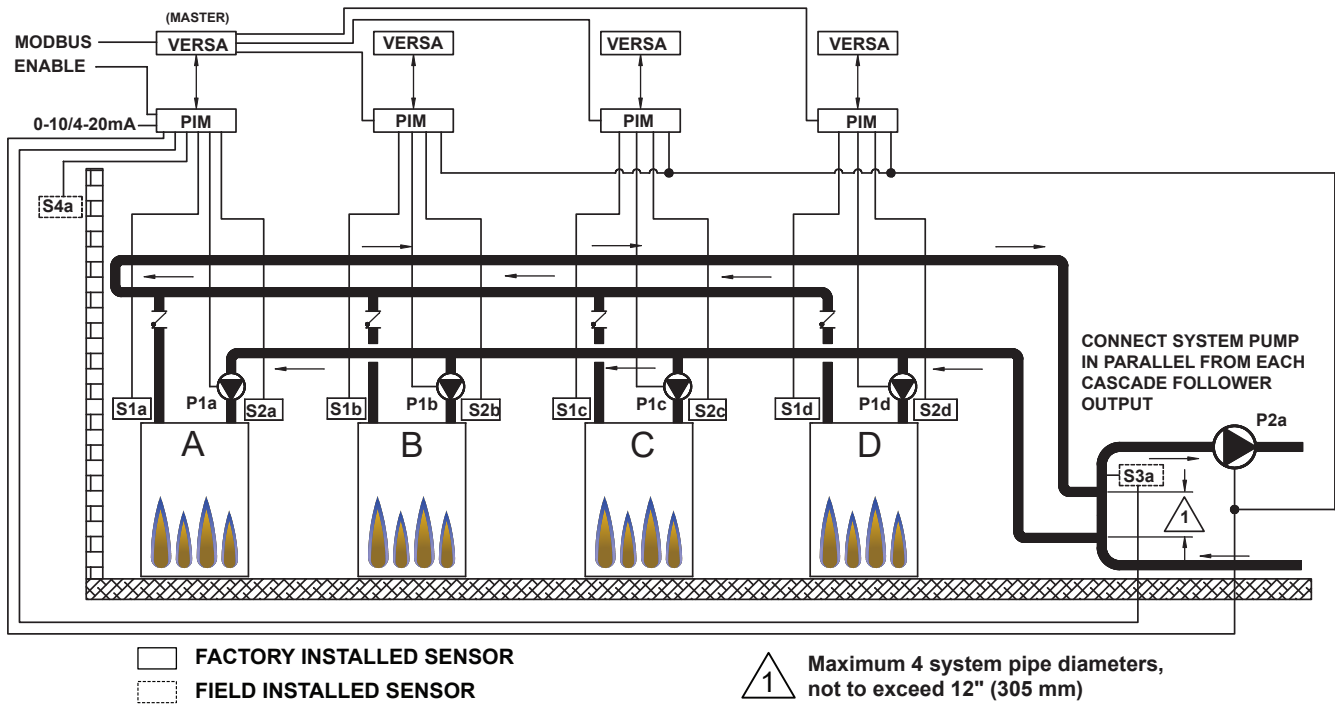

Figure 16. Mode 1 - Recommended Heater Cascade with Primary/Secondary Piping (shown with 4 Units)

**NOTE:** See VERSA IC<sup>®</sup> Manual (241493) for more information on cascade systems.

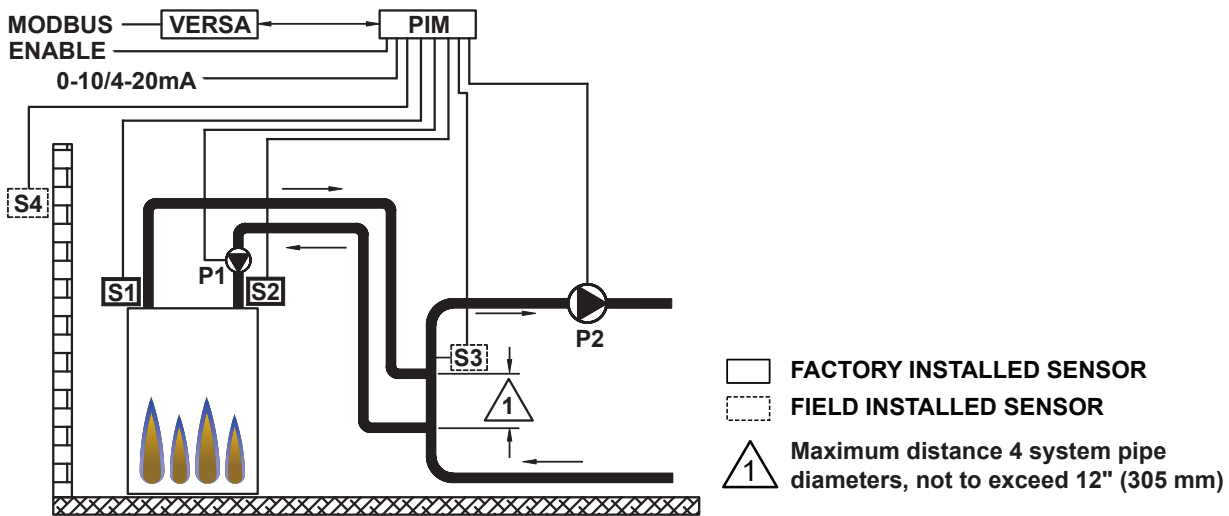

Figure 17. Mode 1 - Single Heater with Primary/Secondary Piping

**APPROVED**

The Heater Pump (P1) is delayed "Off" as user-defined in the Heater menu and the System Pump (P2) is delayed "Off" in the ADJUST menu. The System Pump (P2) runs whenever the system is enabled for heating and the outdoor air temperature is lower than the WWSD temperature setting (if utilized) unless an indirect call-for-heat is present with priority.

**Mode 2**

This mode selection is for hydronic heating systems with single or multiple heaters in primary/secondary piping configuration with or without Outdoor Air Reset (S4) with indirect DHW on the system loop (with or without priority). The system temperature is controlled by the System Sensor (S3). The Indirect DHW Sensor (S5) determines the indirect call/tank setpoint. See **Figure 18**.

The system temperature is boosted to Target Max when using the Indirect DHW Sensor (S5) during an indirect call-for-heat. Priority mode toggles off the System Pump (P2) when an indirect call-for-heat is present. The Heater Pump (P1) runs during any call-for-heat. The Indirect DHW Pump (P3) runs during an indirect call-for-heat with no "Off" delay.

**NOTE:** See **VERSA IC® Manual (241493)** for more information on cascade systems.

**NOTE:** In cascade configuration, the system pump and DHW pump (if applicable) outputs from each cascade member must be connected in parallel to activate the system pump and DHW pump during "limp-along" operation respectively. See **VERSA IC® Manual (241493)** for detailed information.

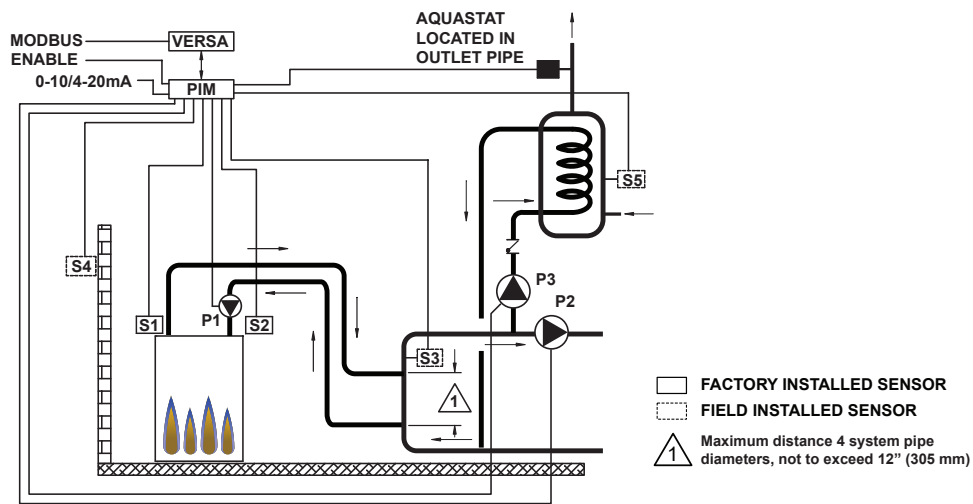

**Figure 18. Mode 2 - Single Heater with Indirect on System Loop - Primary/Secondary Piping**

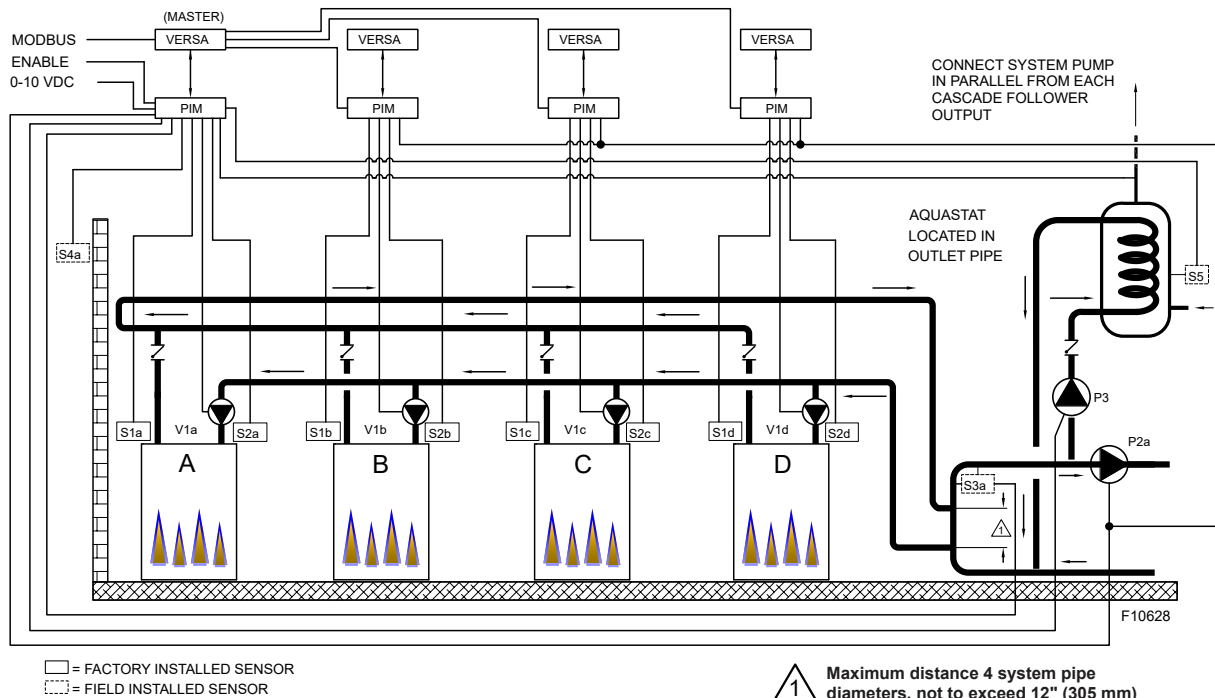

**Figure 19. Mode 2 - Heater Cascade with Indirect on System Loop - Primary/Secondary Piping (shown with 4 Units)**  
**UNCONTROLLED DOCUMENT IF PRINTED**

**APPROVED**

defined in the Heater menu and the System Pump (P2) is delayed "Off" in the ADJUST menu.

The System Pump (P2) runs whenever the system is enabled for heating and the outdoor air temperature is lower than the warm weather shut down (WWSD) temperature setting (if utilized) unless an indirect call-for-heat is present.

**Mode 3**

This mode selection is for hydronic heating systems with single or multiple heaters (in primary/secondary piping configuration with or without Outdoor Air Reset (S4) with indirect DHW on the heater loop (with priority). See **Figure 20**.

The system temperature is controlled by the Supply Sensor (S3) whenever the indirect call-for-heat is not active. The DHW Supply Sensor (S5) determines the indirect call/tank setpoint. During an indirect call-for-heat the heater firing rate is determined by the water temperature at the Indirect Supply Sensor (S6) and the Target Max setting when using the Indirect DHW sensor (S5).

The Heater/Injection Pump (P1) runs during all heat calls regardless of priority. The Indirect DHW Pump (P3) runs during an indirect call-for-heat with no "Off" delay.

The Heater/Injection Pump (P1) is delayed "Off" as user-

**NOTE: A Tank Aquastat can be used in lieu of the Indirect DHW Sensor (S5). See VERSA IC<sup>®</sup> Manual (241493) for additional details.**

**NOTE: See VERSA IC<sup>®</sup> Manual (241493) for more information on cascade systems.**

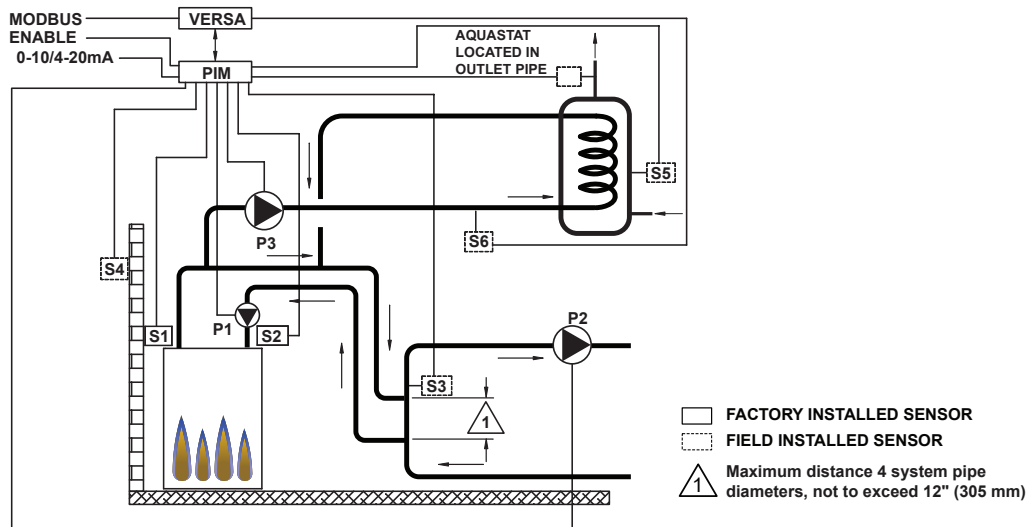

**Figure 20. Mode 3 - Single Heater with Indirect on Heater Loop Primary/Secondary Piping**

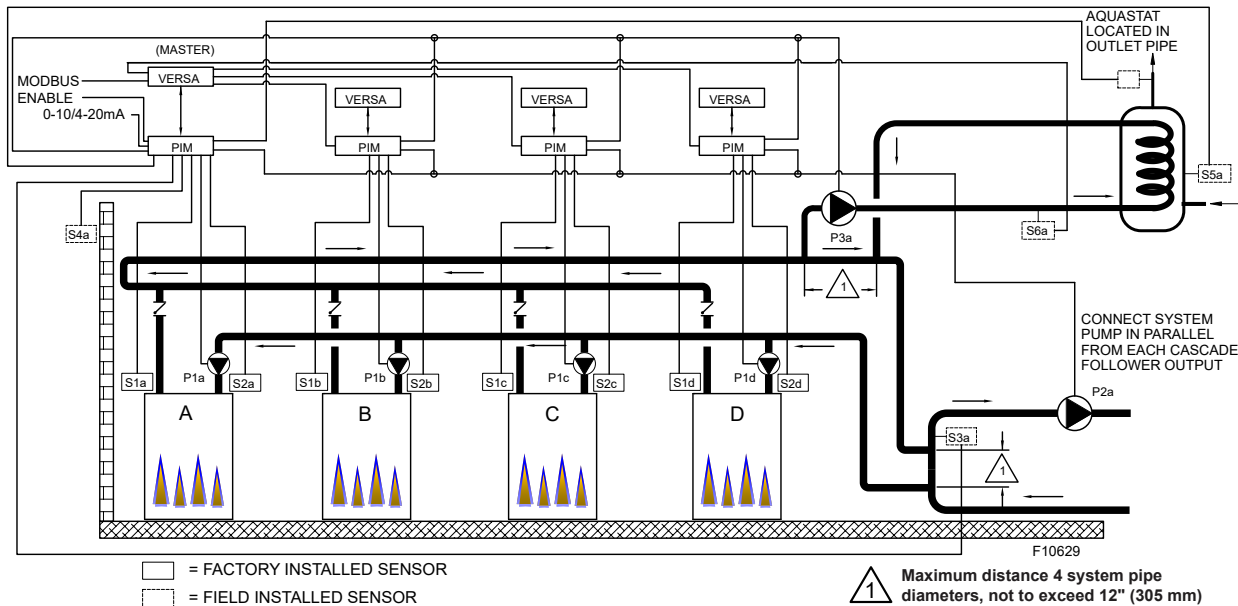

**Figure 21. Mode 3 - Heater Cascade with Indirect on Heater Loop Primary/Secondary Piping (shown with 4 Units)**

**UNCONTROLLED DOCUMENT IF PRINTED**



**NOTE:** In cascade configuration, the system pump and DHW pump (if applicable) outputs from each cascade member must be connected in parallel to activate the system pump and DHW pump during “limp-along” operation respectively. See VERSA IC® Manual (241493) for detailed information.

## Domestic Hot Water

When designing the water piping system for domestic hot water applications, water hardness should be considered. **Table O** indicates the suggested flow rates for soft, medium and hard water. Water hardness is expressed in grains per gallon. See **Figure 22** and **Figure 23**.

**NOTE:** If local codes require a vacuum relief valve, acquire one locally and install per valve manufacturer’s instructions.

## Domestic Hot Water Heater

When the unit is ordered as a water heater, the only application available to it is direct DHW with single or multiple heaters (refer to VERSA IC® Manual (241493) for detailed Cascade operation). The tank temperature is controlled by the System sensor (S3). The Boiler/Injection Pump (P1) runs during any call-for-heat. The System Pump (P2) output is active whenever the system is enabled. The Boiler Pump is delayed “off” as user-defined in the BOILER menu.

**NOTE:** Indirect DHW pump contacts are not active in this configuration.

**NOTE:** Water heaters will operate to a maximum tank temperature of 160°F (71°C). For setpoints above 160°F (71°C), a boiler model configured for high-temperature potable operation must be used and water hardness must be no more than 5 grains per gallon for scale-free operation. **MODE 1** should be used and configured for setpoint operation for process heating applications using a Manual Differential set for between 3°F and 5°F (-16°C and -15°C).

## Potable Water and Space Heating

**CAUTION:** When this heater is used for both potable water and space heating, observe the following to ensure proper operation.

- All piping materials and components connected to the water heater for the space heating application shall be suitable for use with potable water.
- Toxic chemicals, such as used for boiler treatment, shall not be introduced into the potable water used for space heating.
- If the heater will be used to supply potable water, it shall not be connected to any heating system or

components previously used with a non-potable water heating appliance.

- When the system requires water for space heating at temperatures higher than 140°F (60°C), a means such as a mixing valve shall be installed to temper the water in order to reduce scald hazard potential.

**CAUTION:** When water hardness is higher than 15 GPG, a softener **MUST** be used. Failure to do so can cause scale build up and failure of the heat exchanger not covered by warranty.

## Automatic Chemical Feeders

All chemicals must be completely diluted into the water before being circulated through the heater. High chemical concentrations will result when the pump is not running (e.g. overnight).

**CAUTION:** Combustion air must not be contaminated by corrosive chemical fumes which can damage the heater. Such damage will not be covered under warranty..

**CAUTION:** High chemical concentrations from feeders that are out of adjustment will cause rapid corrosion to the heat exchanger. Such damage is not covered under the warranty.

**CAUTION:** Failure of a heat exchanger due to lime scale build-up on the heating surface, low pH, or other chemical imbalance is not covered under the warranty.

Manufacturer standard pump selection for water heater models are shown below.

| Heater Size | Soft Water Pump (4-12 GPG) |     |              |           |            |
|-------------|----------------------------|-----|--------------|-----------|------------|
|             | TACO MDL                   | HP  | Amps @120VAC | GPM/FT HD | ΔT °F (°C) |
| 300         | 0012                       | 1/8 | 1.3          | 30@8.5'   | 19 (11)    |
| 400         | 0012                       | 1/8 | 1.3          | 30@8.5'   | 26 (14)    |
| 500         | 0012                       | 1/8 | 1.3          | 32@7.8'   | 30 (17)    |
| 650         | 1611                       | 1/4 | 5.7          | 55@14'    | 23 (13)    |
| 800         | 1611                       | 1/4 | 5.7          | 57@13'    | 27 (15)    |
| 1000        | 1611                       | 1/4 | 5.7          | 65@9.8'   | 30 (17)    |

Table M. Water Heater Soft Water Pump (4-12 GPG)

| Heater Size | Medium Water Pump (up to 15 GPG) |     |              |           |            |
|-------------|----------------------------------|-----|--------------|-----------|------------|
|             | TACO MDL                         | HP  | Amps @120VAC | GPM/FT HD | ΔT °F (°C) |
| 300         | 0012                             | 1/8 | 1.3          | 30@8.5'   | 19 (11)    |
| 400         | 1611                             | 1/4 | 5.7          | 42@15.9'  | 18 (10)    |
| 500         | 1630                             | 1/2 | 7.0          | 53@20.1'  | 18 (10)    |
| 650         | 1630                             | 1/2 | 7.0          | 65@19'    | 19 (11)    |
| 800         | 1630                             | 1/2 | 7.0          | 70@18.9'  | 22 (12)    |
| 1000        | 1630                             | 1/2 | 7.0          | 85@16'    | 23 (13)    |

Table N. Medium Water Pump (Fixed Speed)

**APPROVED**

| Heater Size | MBTUH (kW/h) |           | Up to 15 GPG |             |                 |                  | Min Flow*   |                 |            | Max Flow**  |                 |            |
|-------------|--------------|-----------|--------------|-------------|-----------------|------------------|-------------|-----------------|------------|-------------|-----------------|------------|
|             | Input        | Output    | ΔT °F (°C)   | GPM (L/min) | ΔP ft.wc. (kPa) | SHL ft.wc. (kPa) | GPM (L/min) | ΔP ft.wc. (kPa) | ΔT °F (°C) | GPM (L/min) | ΔP ft.wc. (kPa) | ΔT °F (°C) |
| 300         | 300 (88)     | 288 (84)  | 16 (9)       | 37 (140)    | 10 (30)         | 14 (42)          | 28 (106)    | 6 (18)          | 21 (12)    | 38 (144)    | 10 (30)         | 15 (8)     |
| 400         | 399 (117)    | 383 (112) | 21 (12)      | 37 (140)    | 10 (30)         | 14 (42)          | 28 (106)    | 6 (18)          | 27 (15)    | 50 (189)    | 17 (51)         | 15 (8)     |
| 500         | 500 (147)    | 480 (141) | 22 (12)      | 44 (167)    | 11 (33)         | 16 (48)          | 33 (125)    | 6 (18)          | 29 (16)    | 62 (235)    | 20 (60)         | 15 (8)     |
| 650         | 650 (191)    | 624 (183) | 21 (12)      | 59 (223)    | 10 (30)         | 17 (51)          | 44 (164)    | 6 (18)          | 28 (16)    | 80 (303)    | 17 (51)         | 16 (9)     |
| 800         | 800 (235)    | 768 (225) | 21 (12)      | 74 (280)    | 11 (33)         | 22 (66)          | 55 (208)    | 7 (21)          | 28 (16)    | 90 (341)    | 16 (48)         | 17 (9)     |
| 1000        | 1000 (294)   | 960 (281) | 22 (12)      | 88 (333)    | 12 (36)         | 24 (72)          | 66 (250)    | 7 (21)          | 29 (16)    | 90 (341)    | 12 (36)         | 21 (12)    |

Pipe sizing based on not exceeding 8 feet per second velocity.

ΔP = Feet of Head.

SHL = System Head Loss of heater plus 100 equivalent feet (30 m) of pipe.

Max flow may require larger than 3 inch piping to not exceed max velocity.

\* Minimum flow based on H<sub>2</sub>O as heating media. Media other than H<sub>2</sub>O may require higher minimum flow rates.

\*\* Maximum flow based on 15°F (8°C) ΔT or 8 feet per second (2.4 m per second) velocity, whichever is less.

**Table O. Water Heater Rates of Flow for Various System Pipe Sizes**

**NOTE: See VERSA IC<sup>®</sup> Manual (241493) for more information on cascade systems.**

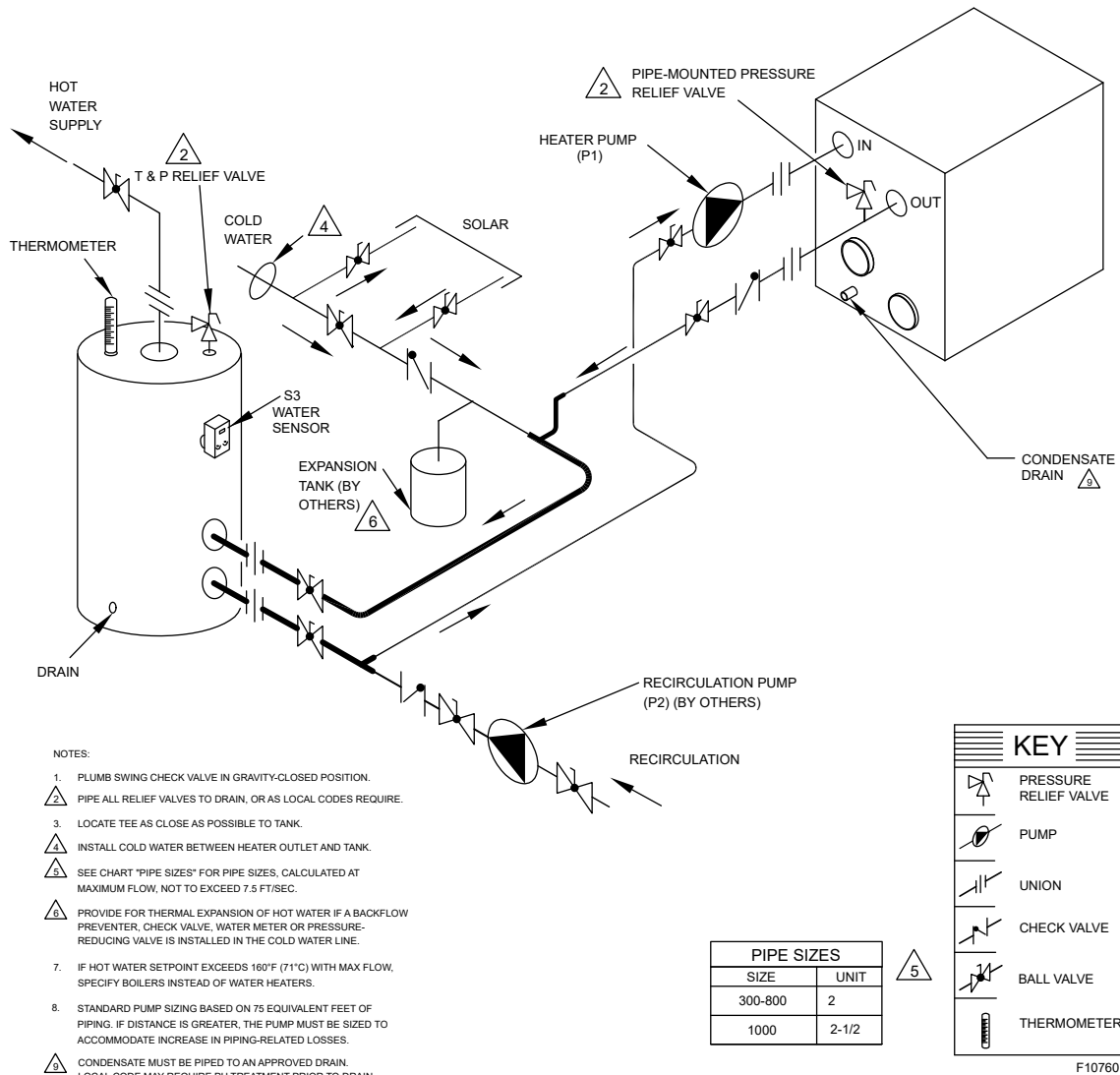

**Figure 22. DHW Configuration, Vertical Tank  
UNCONTROLLED DOCUMENT IF PRINTED**

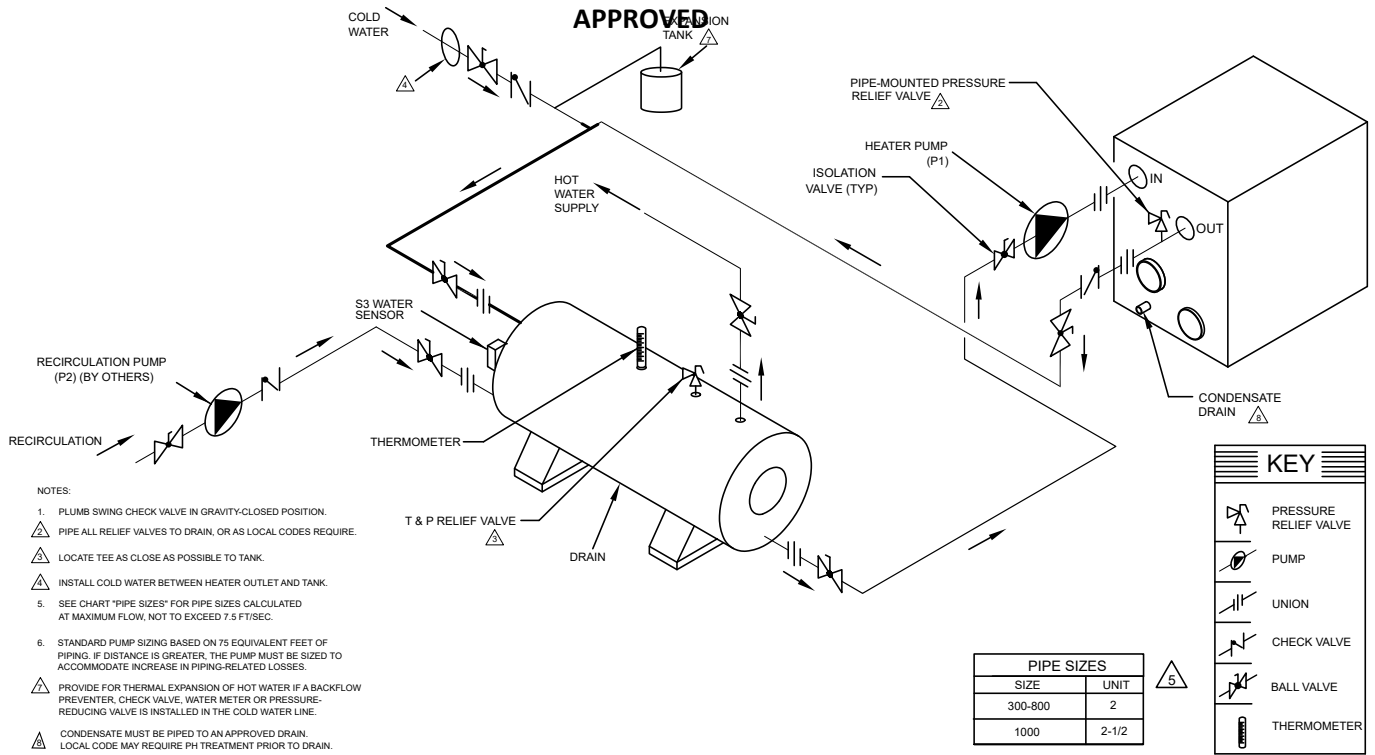

Figure 23. DHW Configuration, Horizontal Tank

**NOTE:** See VERSA IC® Manual (241493) for more information on cascade systems.

## Gas Supply

**⚠ DANGER:** If a unit is converted from Natural to Propane in the field, the rating plate will not match the gas used by the unit. Add a secondary decal near the rating plate to document the conversion.

**⚠ CAUTION:** Fuel grades of other than HD-5 Propane or Natural Gas (980-1080 BTU/ft<sup>3</sup>) will require adjustments, please contact the factory.

A pounds-to-inches regulator of the lock-up type must be installed to reduce the gas supply pressure if it is higher than 10.5" WC for natural gas or 13" WC for propane gas. This regulator should be installed following the regulator manufacturers instructions refer to **Table P** for maximum pipe lengths.

## Gas Supply Connection

Gas piping must have a sediment trap upstream of the heater gas connection and a field-supplied manual shut-off valve upstream of the sediment trap near the heater jacket to allow for service.

**⚠ CAUTION:** The heater must be disconnected from the gas supply during any pressure testing of the gas supply system at test pressures in excess of 1/2 psi (3.45 kPa).

Relieve test pressure in the gas supply line prior to re-connecting the heater and its manual shut-off valve to the gas supply line. **FAILURE TO FOLLOW THIS PROCEDURE MAY DAMAGE THE GAS VALVE.** Over-pressurized gas valves are not covered by warranty. The heater and its gas connections shall be leak-tested before placing the appliance in operation. Use soapy water for leak test. DO NOT use an open flame.

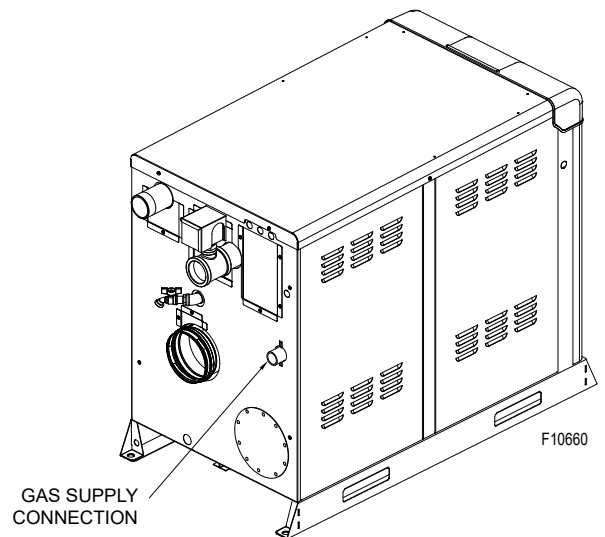

300-500 = 1" NPT  
650-1000 = 1-1/4" NPT

Figure 24. Gas Supply Connection

**APPROVED**

| Heater Size | 1" NPT  |          | 1-1/4" NPT |           | 1-1/2" NPT |            | 2" NPT   |           |
|-------------|---------|----------|------------|-----------|------------|------------|----------|-----------|
|             | Nat     | Pro      | Nat        | Pro       | Nat        | Pro        | Nat      | Pro       |
| 300         | 45 (15) | 150 (46) | 175 (53)   | 550 (168) | 350 (107)  | 1100 (335) |          |           |
| 400         | 25 (8)  | 80 (24)  | 100 (30)   | 375 (114) | 200 (61)   | 650 (198)  |          |           |
| 500         | 15 (5)  | 40 (12)  | 65 (20)    | 250 (76)  | 150 (46)   | 450 (137)  |          |           |
| 650         |         |          | 40 (12)    | 150 (46)  | 85 (26)    | 300 (91)   | 300 (91) | 850 (259) |
| 800         |         |          | 30 (9)     | 90 (27)   | 60 (18)    | 200 (60)   | 200 (60) | 600 (182) |
| 1000        |         |          | 20 (6)     | 50 (15)   | 40 (12)    | 150 (46)   | 125 (38) | 450 (137) |

Natural gas - 1,000 btu/ft<sup>3</sup>, 0.60 specific gravity at 0.5" W.C. pressure drop / Propane gas - 2,500 btu/ft<sup>3</sup>, 1.53 specific gravity at 0.6" W.C. pressure drop.  
 Lengths based on Sched 40 BIP - for other materials consult local codes.  
 Elbows as 10 ft equivalent pipe length.

**Table P. Gas Supply Piping (Sched 40 BIP) (ft./m)**

**CAUTION:** Only sealant tape or a pipe compound rated for use with natural and propane gases is recommended. Apply sparingly only on male pipe ends, leaving the two end threads bare.

**CAUTION:** Support gas supply piping with hangers, not by the heater or its accessories. Make sure the gas piping is protected from physical damage and freezing, where required.

## Electrical Power Connections

**WARNING:** Heater is designed for factory-installed 120VAC or factory-installed 208VAC. See details in "Multiple Voltage Configurations" on page 26.

**WARNING:** Electrical power connection must be performed by qualified licensed electrician(s) for the voltage being applied.

Installations must follow these codes:

- National Electrical Code and any other national, state, provincial or local codes or regulations having jurisdiction.
- Safety wiring must be NEC Class 1.
- Heater must be electrically grounded as required by the NEC.
- In Canada, CSA C22. 1 C.E.C. Part 1.

**NOTE:** A 120VAC (.75A Max.) outlet is provided on the bottom of the Junction Box for general use.

Before starting the heater, check to ensure proper voltage to the heater.

Pumps must use a separate power supply and run the power through a field-supplied contactor. Use appropriately-sized wire as defined by NEC, CSA and/or local codes. All primary wiring should be 125% of minimum rating.

If any of the original wire as supplied with the heater must be replaced, it must be replaced with 105°C wire or its equivalent.

All high-voltage wiring connections to the heater are made inside the rear wiring box as shown in **Figure 25**. There are three factory-supplied pilot duty relays in the rear wiring box to provide an enable signal via dry contact (5A max) for the heater pump/isolation valve, system pump, and indirect DHW pump as required for the system depending on the mode selected within the VERSA IC<sup>®</sup> system.

## Gas Supply Pressure

A minimum of 4" WC and a maximum of 10.5" WC gas pressure is required under load and no-load conditions for natural gas at the heater. A minimum of 8" WC and a maximum of 13" WC is required for propane gas at the heater. The gas pressure regulator(s) supplied on the heater is for low-pressure service. If upstream pressure exceeds these values, an intermediate gas pressure regulator, of the lockup type, must be installed.

When connecting additional gas utilization equipment to the gas piping system, the existing piping must be checked to determine if it has adequate capacity for the combined load.

**CAUTION:** For proper operation, no more than a 30% drop in gas supply pressure from no-load to full-load conditions is acceptable. Under no circumstances should the pressure be outside the listed operational range.

APPROVED

| Heater Size | Heater Amp Draw |        |
|-------------|-----------------|--------|
|             | 120VAC          | 208VAC |
| 300         | <7.5 A          | <5.0 A |
| 400         | <7.5 A          | <5.0 A |
| 500         | <5.0 A          | <5.0 A |
| 650         | <5.0 A          | <5.0 A |
| 800         | <7.5 A          | <7.5 A |
| 1000        | <7.5 A          | <7.5 A |

Table Q. Expected Heater Amp Draw

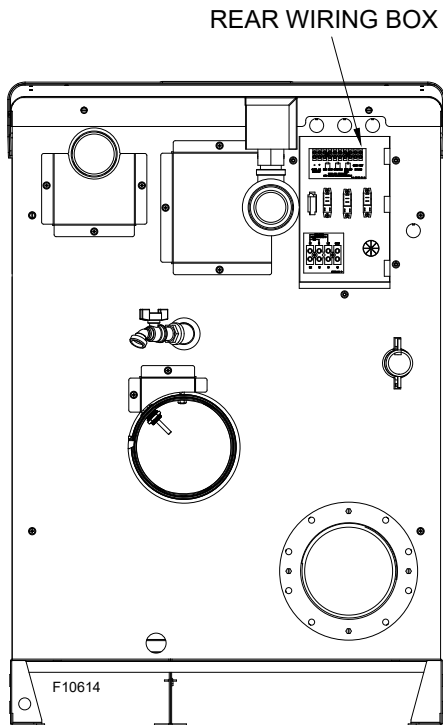

Figure 25. Rear Wiring Box Location

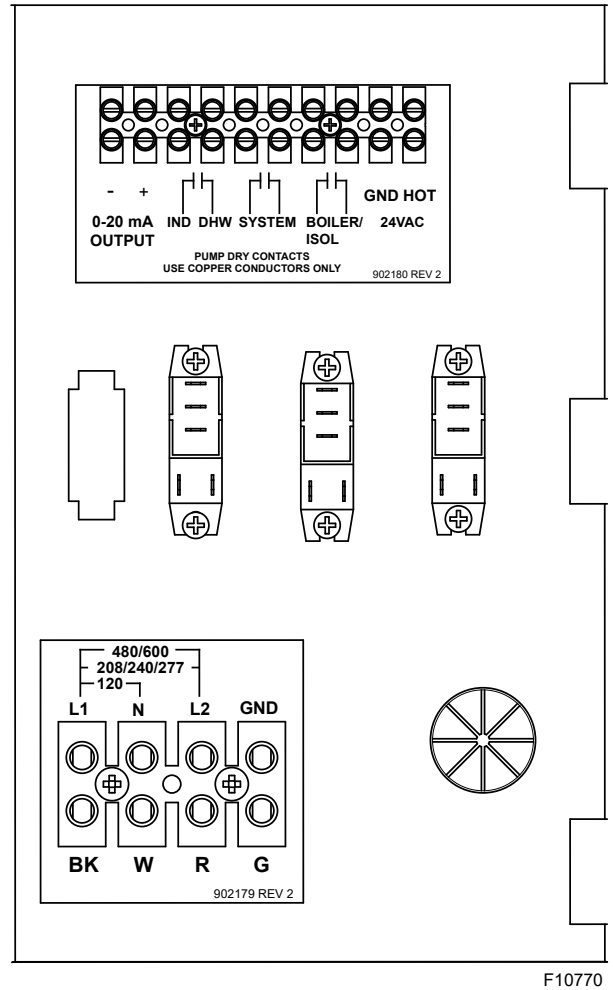

Figure 26. Rear Wiring Box

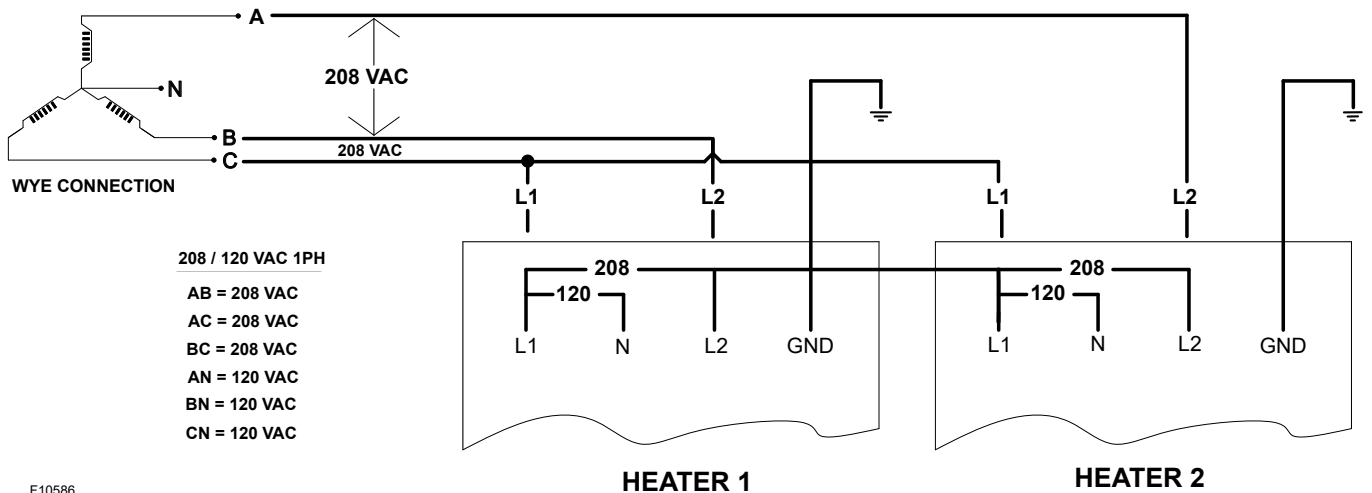

Figure 27. WYE Electrical Connections for 120/208 VAC  
UNCONTROLLED DOCUMENT IF PRINTED

**APPROVED**  
**Field Connected Devices**

**Multiple Voltage Configurations**

The heater can be built for 120VAC or 208VAC supply voltages.

| Unit Size  | Input Voltage            | For wiring diagram, see <b>page 55</b> . |
|------------|--------------------------|--|
| All Models | 120VAV - No Transformer  |  |
|            | 208VAC - Has Transformer |  |

**Table R. Voltage Configurations**

**NOTE:** 24VAC is available at the rear box to be used for the Isolation valve actuation.

**Check Power Source**

**WARNING:** Using a multimeter, check the following voltages at the circuit breaker panel prior to connecting any equipment. Make sure measurement is performed between proper hot lines and/or neutral lines.

Figure 27 represents the most common WYE configuration at the main power supply from the building circuit breaker for 120 or 208VAC.

**Making the Electrical Connections**

1. Verify that circuit breaker is properly sized by referring to heater rating plate. A dedicated circuit breaker shall be provided.
2. Observe proper wire colors while making electrical connections. Many electronic controls are polarity sensitive. Components damaged by improper electrical installation are not covered by warranty.
3. Provide overload protection and a disconnect means for equipment serviceability as required by local and state code.
4. Conduit shall not be used as the earth ground.

**NOTE:** A grounding electrode conductor shall be used to connect the equipment grounding conductors, the equipment enclosures, and the grounded service conductor to the grounding electrode.

**Field Wiring Connection**

**Field-Connected Devices**

It is strongly recommended that all individually-powered control modules and the heater should be supplied from the same power source.

Install heater controls, thermostats, or building management systems in accordance with the applicable manufacturer's instructions.

**DANGER: SHOCK HAZARD!**

**NOTE:** Minimum 18 AWG, 105°C, stranded wire must be used for all low voltage (less than 30 volts) external connections to the heater. Solid conductors should not be used because they can cause excessive tension on contact points. Install conduit as appropriate. All high voltage wires must be the same size (105°C, stranded wire) as the ones on the unit or larger.

**CAUTION:** Label all wires prior to disconnection when servicing controls. Wiring errors can cause improper and dangerous operation. Verify proper operation after servicing.

Make sure electrical power to the heater is disconnected to avoid potential serious injury or damage to components.

**Wiring the Optional 0–10 Volt Building Control Signal**

1. A signal from an energy management system (EMS) or building management system (BMS) may be connected to the heater. This signal should be a 0-10 volt positive DC signal. The energy management system can be used to control either the setpoint temperature of a single heater or a cascade of multiple heaters, or the firing rate of a single heater.

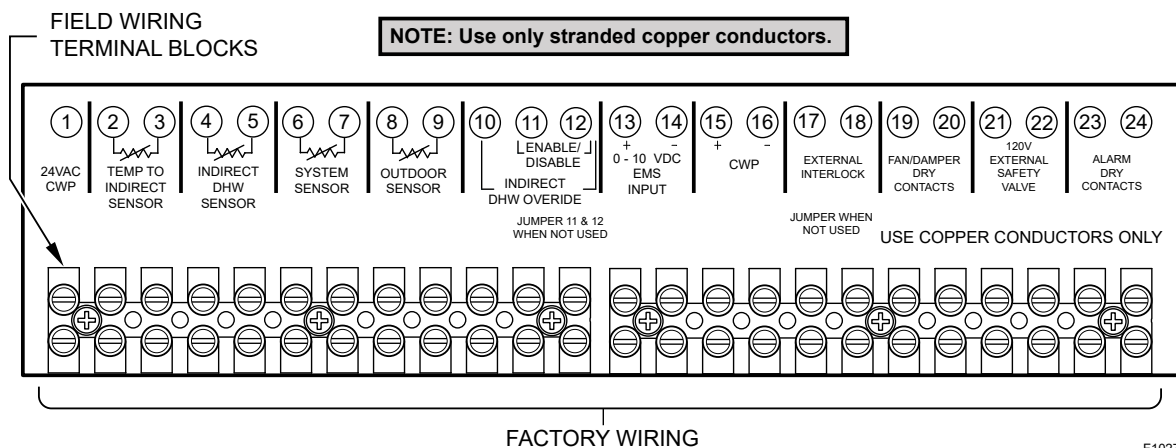

**Figure 28. Low-Voltage Field Wiring**  
**UNCONTROLLED DOCUMENT IF PRINTED**

F10271



APPROVED

- To enable this remote control function, set DIP switch 5 to the UP position on the PIM. DIP switch 5 Toggles between an EMS (UP) signal or a demand signal from the VERSA (DOWN). DIP switch 2 on the PIM toggles between a Direct Drive (UP) input and a Target Temperature (DOWN) setpoint.
- For a 4-20mA application, refer to the VERSA IC<sup>®</sup> Manual (241493).
- Connect an Energy Management system or other auxiliary control signal to the terminals marked 0-10V (+/-) on the field wiring terminals. See **Figure 28**. Caution should be used to ensure that the +0-10V connection does not create a short to ground.
- Contact closure across the Enable/Disable connection is required for heater operation in this configuration.

**CAUTION:** Ensure that the +0-10V connection does not create a short to ground. +0-10V signal is polarity sensitivity and must not be reversed. +0-10VDC signal must not exceed 10VDC.

### Wiring the Enable/Disable

Connect the Enable/Disable (terminals 11, 12) wiring to the field wiring terminals as shown in **Figure 28** and in place of the factory-installed jumper. Alternately, any dry contact closure (including a remote thermostat) across these terminals will enable the heater to run.

**CAUTION:** Ensure neither of the terminals are shorted to ground.

The 3-position rocker switch (adjacent to the touchscreen user interface) must be in the "RUN" position for the heater to operate when enabled.

**CAUTION:** The Enable/Disable signal may be overridden when the VERSA control is configured for MODBUS "TEMP" or "RATE". Disable MODBUS prior to servicing the heater.

FIELD WIRING  
KNOCKOUT

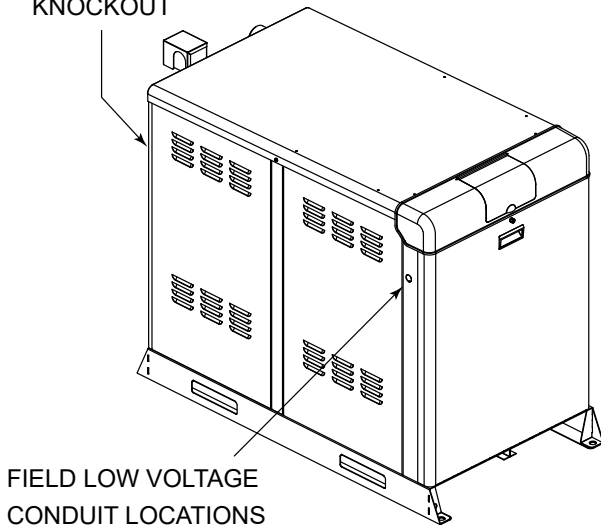

### Wiring the System Sensor

The System Sensor (S3) is required for all Primary/Secondary and all cascade configurations for all selectable modes unless the unit's firing rate will be controlled by an external source, such as our TempTracker MOD+ Hybrid sequencer. Proper placement and method of installation are critical for proper operation of the system. See "Applications and Modes".

- When using a System Sensor (S3), connect the sensor wires to the terminals marked (6, 7) SYSTEM SENSOR. See **Figure 28**.
- Use a minimum of 18 AWG stranded wire for runs up to 150 ft. (46 m).
- Install the system sensor in a drywell (option B-31) within 5 ft. (1.5 m) downstream of the de-coupler (primary/secondary system) or last heater (primary). See **Figure 14** as appropriate.

### Wiring the Boiler Pump

Connect the pump for the unit (boiler or water heater) enable wiring to the field-wiring terminal block inside the junction box. The connections are dry contacts rated for pilot duty only (5A maximum). The pump relay is field-supplied. See **Figure 30** for details.

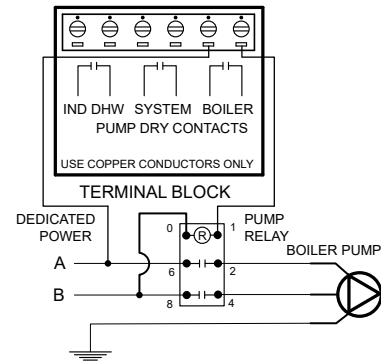

Figure 29. Low-Voltage Wiring/Transformer Box

FIELD WIRING  
TERMINAL BLOCKS

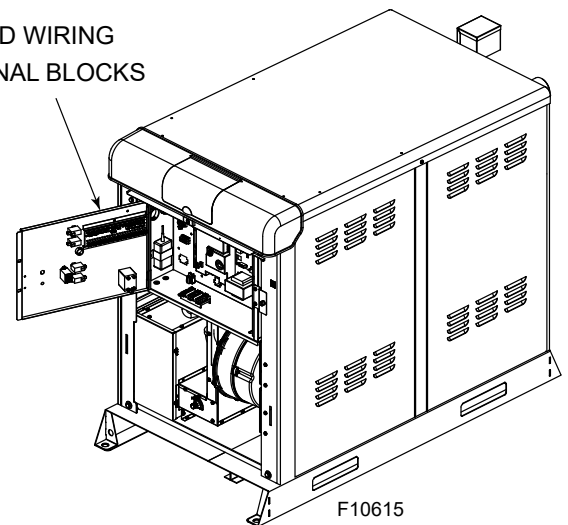
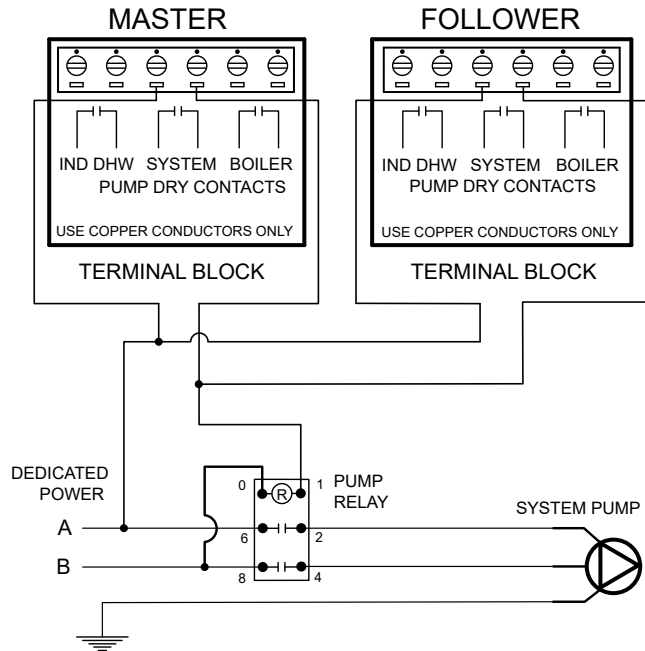

Figure 30. Low-Voltage Wiring/Transformer Box  
UNCONTROLLED DOCUMENT IF PRINTED

## APPROVED

### Cascade System Pump and Sensor Wiring

1. On the heater designated as the Master, connect the system pump enable wiring to the field-wiring terminal block inside the junction box. The connections are dry contacts rated for pilot duty only (5A maximum).
2. Connect the system supply sensor to terminals 6 and 7 on the field wiring strip located on the Master heater. See **Figure 28**.



**Figure 31. Heater Cascade System Pumps**

3. Connect the Outdoor sensor (if used) to terminals 8 and 9 on the field wiring strip located on the Master heater. See **Figure 28**.
4. Connect the Enable/Disable wiring to terminals 11 and 12 on the field wiring strip located on the Master heater. This connection must be provided through dry contacts closure. See **Figure 28**. Applying 24VAC to these terminals will result in blowing the fuse on PIM.

**NOTE:** The dry contacts closure can come from a room thermostat or a remote relay. No power of any kind should be applied to either of these terminals.

### Cascade Follower Pump and Sensor Wiring

1. Once the primary heater has been identified, additional heaters will be designated as follower heaters. Ensure DIP switch 2 on each follower VERSA is set to the OFF/Down position.
2. For cascade configurations system pump and DHW pump, Follower outputs must be connected in parallel respectively in order to support operation during "limp-along" operation.

### Wiring the Outdoor Sensor

1. If using an Outdoor Sensor, connect the sensor wires to the terminals (8 and 9) marked OUTDOOR SENSOR. See **Figure 28**.

**CAUTION:** Ensure sensor wiring is not shorted to ground.

2. Use a minimum 18 AWG stranded wire for runs of up to 150 ft. (46 m).
3. Mount the outdoor sensor on an exterior surface of the building, preferably on the north or west facing side in an area that will not be affected by direct sunlight.

### Wiring the Indirect DHW Sensor (Optional)

Connect the indirect tank sensor to the terminals (4 and 5) marked INDIRECT DHW SENSOR. See **Figure 28**. Caution should be used to ensure neither of these terminals becomes connected to ground. When using an indirect DHW Sensor to control tank temperature, contact closure is required across the indirect override connections for proper operation.

**NOTE:** Alternately, a thermostat contact closure can be used in lieu of the sensor for indirect operation. Connect the thermostat to the terminals (10 and 12) marked INDIRECT DHW OVERRIDE.

When the Indirect DHW call-for-heat is active, the PIM communicates this to the VERSA. The VERSA calculates the optimal operation and sends the firing rate and pump output requests to the PIM so it can activate the Indirect DHW Pump and Heater Pump as needed. If optional Indirect DHW Sensor is connected, the PIM will pass this signal to the VERSA. This allows the VERSA to optimize the Indirect DHW demand to maintain the Indirect DHW setpoint. The Indirect DHW thermostat switch closure is still required when using the Indirect DHW Sensor. If a VERSA is not present the PIM shall activate the Indirect DHW pump whenever the Indirect DHW call is active. The Heater pump will also be activated based on the Indirect DHW piping configuration setting.

**CAUTION:** Sensor and control wiring must NOT be run in chases with line voltage.

**CAUTION:** To prevent an over-temperature condition from occurring in the indirect DHW system during "limp-along" operation, set PIM operator dial to be equal to DHW Target temperature. See VERSA IC<sup>®</sup> Manual (241493) for more information on "limp-along" operation.

### Wiring the Cascade System - Communication Bus

Refer to VERSA IC<sup>®</sup> Manual (241493) for details on Cascade wiring and communication setup.



## Modbus BMS Communication

The VERSA IC<sup>®</sup> is equipped as standard with a communications port for connectivity to building automation via Modbus protocol.

Refer to the VERSA IC<sup>®</sup> Manual (241493) for further information. The heater may be equipped with protocol converter. See ProtoNode Manual (241515) and wiring diagram.

## Alarm Connection

An alarm annunciator or light may be connected to the alarm contacts on the field wiring terminal strip.

The alarm contacts are 3A rated dry contacts on a normally-open relay that close during fault or lockout conditions, and the maximum voltage across the contacts is 30 VAC or 30 VDC. See the Field Wiring as shown in **Figure 28**.

In a cascade system with an alarm condition at one or more units, all alarm contacts within the cascade will be energized indicating a fault condition. This feature can be enabled or disabled, refer to VERSA IC<sup>®</sup> Manual (241493) for further details on "Cascaded Alarm".

## Venting - General

**CAUTION:** Proper installation of flue venting is critical for the safe and efficient operation of the heater.

**NOTE:** Factory strongly recommends installing the vent system before water piping. This will ensure that the venting system and associated components will fit into the allotted space for proper operation.

## Appliance Categories

Heaters are divided into four categories based on the pressure produced in the exhaust and the likelihood of condensate production in the vent.

**Category I** – A heater which operates with a non-positive vent static pressure and with a vent gas temperature that avoids excessive condensate production in the vent.

**Category II** – A heater which operates with a non-positive vent static pressure and with a vent gas temperature that may cause excessive condensate production in the vent.

**Category III** – A heater which operates with a positive vent pressure and with a vent gas temperature that avoids excessive condensate production in the vent.

**Category IV** – A heater which operates with a positive vent pressure and with a vent gas temperature that may cause excessive condensate production in the vent.

See **Table S** for appliance category requirements.

**NOTE:** For additional information on appliance categorization, see appropriate ANSI Z21 Standard and the NFGC (U.S.), or B149.1 (Canada), or applicable provisions of local building codes.

**WARNING:** Mixing of different manufacturers venting material is not permitted as this may create an unsafe condition.

**CAUTION:** Condensate drains for the vent piping are required for installations of the heater. Follow vent manufacturer instructions for installation and location of condensate drains in the vent. Condensate drain must use a trap and the trap must be primed with water to prevent flue gas leakage and must be routed to an appropriate container for treatment before disposal, as required by local codes.

**WARNING:** Contact the manufacturer of the vent material if there is any question about the appliance categorization and suitability of a vent material for application on a Category IV vent system. Using improper venting materials can result in personal injury, death or property damage.

**NOTE:** Ensure that clearances are maintained per **Table F** and **Table I**.

Use only the special gas vent pipes listed for use with Category IV gas burning heaters as listed in **Table T** and **Table U**. Follow the vent manufacturer's installation instructions carefully.

In addition to the stainless steel and polypropylene vents listed in **Table T** and **Table U**, the heater is also certified for use with PVC, CPVC, and vent products.

## Extractors, Draft Inducers, and Motorized Combustion Air Dampers

When extractors or inducers are used in the venting system, they must be interlocked with each connected appliance, to ensure proper operation. If individual motorized combustion air dampers are used, they must be interlocked to their respective appliance. See Field Wiring Connection section of this manual for proper wiring instructions, using Fan/Damper dry contacts and external interlock.

## Support of Vent Stack

The weight of the vent stack or chimney must not rest on the heater vent connection. Support must be provided in compliance with applicable codes. The vent should also be installed to maintain proper clearances from combustible materials.

**APPROVED**

| Certified Materials   | Exhaust Configuration               | Heater Venting Category | Combustion Air Supply                        | Combustion Air Inlet Material          |
|---|-------------------------------------|-------------------------|--|--|
| PVC, CPVC,<br>Polypropylene and<br>Stainless Steel<br>UL-Listed<br>ANSI/ASTM D1785 Sch<br>40 PVC, ANSI ASTM<br>F441 Sch 40 CPVC | Vertical Venting                    | IV                      | From Inside Building<br>(Non-Direct Venting) |  |
|   | Horizontal Through-the-Wall Venting |                         |  |  |
|   | Vertical Venting                    |                         | From Outside Building<br>(Direct Venting)    | Galvanized Steel<br>PVC<br>ABS<br>CPVC |
|   | Horizontal Through-the-Wall Venting |                         |  |  |

**Table S. Venting Category Requirements**

| Centrotherm - InnoFlue   |           |                     |               |  |                                     |                 |
|--------------------------|-----------|---------------------|---------------|--|-------------------------------------|-----------------|
| Heater Size              | Vent Size | Air Intake Terminal | Vent Terminal | Vent Pipe  | Vent Pipe with Test Port            | Vent Adapter    |
| 300                      | 4         | ISELL0487           | ISTT0420      | 4" InnoFlue Vent (ISVL046x)<br>x = 1, 2, 3, 6, 10 ft | 4" Test port InnoFlue Vent (ISTP04) | ISAAL0404       |
| 400                      |           |                     |               |  |                                     |                 |
| 500                      |           |                     |               |  |                                     |                 |
| 650                      | 6         | ISEL0687            | ISTT0620      | 6" InnoFlue Vent (ISVL06X)<br>x = 1, 2, 3, 6, 10 ft  | 6" Test port InnoFlue Vent (ISTP06) | ISAAL0606       |
| 800                      |           |                     |               |  |                                     |                 |
| 1000                     |           |                     |               |  |                                     |                 |
| M&G Duravent - "PolyPro" |           |                     |               |  |                                     |                 |
| Heater Size              | Vent Size | Air Intake Terminal | Vent Terminal | Vent Pipe  | Vent Pipe with Test Port            | Vent Adapter    |
| 300                      | 4         | 90° Elbow           | 4PPS-TTBL     | 4" PolyPro (4PPS-xL),<br>x = 12, 36, 72 in           | 4PPS-TPL                            | 4PPS-04PVC-4PPF |
| 400                      |           |                     |               |  |                                     |                 |
| 500                      |           |                     |               |  |                                     |                 |
| 650                      | 6         |                     | 6PPS-TTBL     | 6" PolyPro (6PPS-xL),<br>x = 12, 36, 72 in           | 6PPS-TPL                            | 6PPS-06PVC-6PPF |
| 800                      |           |                     |               |  |                                     |                 |
| 1000                     |           |                     |               |  |                                     |                 |
| Z Flex - "Z Dens"        |           |                     |               |  |                                     |                 |
| Heater Size              | Vent Size | Air Intake Terminal | Vent Terminal | Vent Pipe  | Vent Pipe with Test Port            | Vent Adapter    |
| 300                      | 4         | 90° Elbow           | 2ZDTT4        | 4" Z Dens (2ZDP4x),<br>x = 12, 24, 36, 72 in         | 2ZDTP4                              | 2ZDCPVC-4       |
| 400                      |           |                     |               |  |                                     |                 |
| 500                      |           |                     |               |  |                                     |                 |
| 650                      | 6         |                     | 2ZDTT6        | 6" Z Dens (2ZDP6x),<br>x = 12, 24, 36, 72 in         | 2ZDTP6                              | 2ZDCPVC-6       |
| 800                      |           |                     |               |  |                                     |                 |
| 1000                     |           |                     |               |  |                                     |                 |

**Table T. Certified Polypropylene Horizontal Vent Termination and Adapter - Category IV**

**APPROVED**

| <b>M&amp;G DuraVent - "Fas-N-Seal"</b> |           |                     |                      |  |                          |               |
|--|-----------|---------------------|----------------------|--|--------------------------|---------------|
| Heater Size                            | Vent Size | Air Intake Terminal | Vent Terminal        | Vent Pipe  | Vent Pipe with Test Port | Vent Adapter  |
| 300                                    | 4         | 90° Elbow           | FSTT4 or D15 (4")    | 4" Fas-N-Seal (FSVLx04)<br>x = 6, 12, 18, 24, 36 in                | FSTP04                   | FSA-4PVC-4FNS |
| 400                                    |           |                     |                      |  |                          |               |
| 500                                    |           |                     |                      |  |                          |               |
| 650                                    | 6         |                     | FSTT6 or D15 (6")    | 6" Fas-N-Seal (FSVL3606)<br>x = 6, 12, 18, 24, 36 in               | FSTP06                   | FSA-6PVC-6FNS |
| 800                                    |           |                     |                      |  |                          |               |
| 1000                                   |           |                     |                      |  |                          |               |
| <b>Heat Fab - Saf-T Vent EZ Seal</b>   |           |                     |                      |  |                          |               |
| Heater Size                            | Vent Size | Air Intake Terminal | Vent Terminal        | Vent Pipe  | Vent Pipe with Test Port | Vent Adapter  |
| 300                                    | 4         | 90° Elbow           | 9414TERM or D15 (4") | 4" Saf-T-Vent (9402), (9405), (9408)                               | 9401PRB                  | 9401PVC       |
| 400                                    |           |                     |                      |  |                          |               |
| 500                                    |           |                     |                      |  |                          |               |
| 650                                    | 6         |                     | 9614TERM or D15 (6") | 6" Saf-T-Vent (9602-316), (9605-316), (9608-316)                   | 9601PRB                  | 9601PVC       |
| 800                                    |           |                     |                      |  |                          |               |
| 1000                                   |           |                     |                      |  |                          |               |
| <b>Z Flex - "Z Vent"</b>               |           |                     |                      |  |                          |               |
| Heater Size                            | Vent Size | Air Intake Terminal | Vent Terminal        | Vent Pipe  | Vent Pipe with Test Port | Vent Adapter  |
| 300                                    | 4         | 90° Elbow           | 2SVSTB04 or D15 (4") | 4" Z Vent (2SVEPWCF0x)<br>x = 4.5 in, 1, 1.5, 2, 3, 4, 5, 8, 10 ft | 2SVSPRTO4.5              | 2SVSTTAA04.5  |
| 400                                    |           |                     |                      |  |                          |               |
| 500                                    |           |                     |                      |  |                          |               |
| 650                                    | 6         |                     | 2SVSTB06 or D15 (6") | 6" Z Vent (2SVEP0x)<br>x = 6.5 in, 1, 1.5, 2, 3, 4 ft              | 2SVSPRTO6.5              | 2SVSTTAA06    |
| 800                                    |           |                     |                      |  |                          |               |
| 1000                                   |           |                     |                      |  |                          |               |

**Table U. Certified Stainless Steel Horizontal Vent Termination and Adapters - Category IV**

## Vent Terminal Location

**NOTE:** During winter months check the vent cap and make sure no blockage occurs from build-up of snow or ice.

1. Condensate can freeze on the vent cap. Frozen condensate on the vent cap can result in a blocked flue condition.
2. Give special attention to the location of the vent termination to avoid possibility of property damage or personal injury.
3. Gases may form a white vapor plume in winter. The plume could obstruct a window view if the termination is installed near windows.
4. Prevailing winds, in combination with below-freezing temperatures, can cause freezing of condensate and water/ice build-up on buildings, plants or roofs.
5. The bottom of the vent terminal and the air intake shall be located at least 12" (305 mm) above grade, including normal snow line.
6. Un-insulated single-wall Category IV metal vent pipe shall not be used outdoors in cold climates for venting gas-fired equipment without insulation.
7. Through-the-wall vents for Category IV appliances shall not terminate over public walkways or over an area where condensate or vapor could create a nuisance or hazard or could be detrimental to the operation of regulators, relief valves, or other equipment.
8. Locate and guard vent termination to prevent accidental contact by people or pets.
9. DO NOT terminate vent in window well, stairwell, alcove, courtyard or other recessed area.

## APPROVED

### Canadian Installations

Refer to latest edition of the B149.1 Installation Code.

A vent shall not terminate:

1. Directly above a paved sidewalk or driveway.
2. Within 6 ft. (1.8 m) of a mechanical air supply inlet to any building.
3. Above a meter/regulator assembly within 3 ft. (915 mm) horizontally of the vertical center-line of the regulator.
4. Within 6 ft. (1.8 m) of any gas service regulator vent outlet.
5. Less than 1 ft. (305 mm) above grade level.
6. Within 3 ft. (915 mm) of a window or door which can be opened in any building, any non-mechanical air supply inlet to any building or the combustion air inlet of any other appliance.
7. Underneath a veranda, porch or deck, unless the veranda, porch or deck is fully open on a minimum of two sides beneath the floor, and the distance between the top of the vent termination and the underside of the veranda, porch or deck is greater than 1 ft. (305 mm).

### Venting Installation Tips

Support piping (See vent manufacturer's instructions):

- horizontal runs—at least every 5 ft. (1.5 m)
- vertical runs—use braces at least every 10 ft. (3 m) under or near elbows

**⚠ WARNING:** Examine the venting system at least once a year. Check all joints and vent pipe connections for tightness, corrosion or deterioration.

### Venting Configurations

For heaters connected to gas vents or chimneys, vent installations shall be in accordance with the NFGC (U.S.), or B149.1 (Canada), or applicable provisions of local building codes.

**⚠ CAUTION:** This venting system may require the installation of supplemental condensate drains in the vent piping per the vent manufacturer's instructions. Failure to install these condensate drains in the venting system may cause a non-warrantable failure.

Heaters ship PVC-ready, no adapters required. An adapter will be required when venting with either polypro or stainless steel flue.

### Stainless Steel and Polypropylene - Vertical Venting (Category IV)

#### Installation

The maximum and minimum venting length for this heater is shown in **Table V**.

10. DO NOT terminate above any door, window, or gravity air intake. Condensate can freeze, causing ice formations.
11. Locate or guard vent to prevent condensate from damaging exterior finishes. Use a rust-resistant sheet metal backing plate against brick or masonry surfaces.
12. DO NOT extend exposed vent pipe outside of building beyond the minimum distance required for the vent termination. Condensate could freeze and block vent pipe.

### U.S. Installations

Refer to the latest edition of the National Fuel Gas Code.

Vent termination requirements are as follows:

1. Vent must terminate at least 4 ft. (1.2 m) below or 4 ft. (1.2 m) horizontally from, window or gravity air inlet to the building.
2. The vent for this appliance shall not terminate:
  - a. over public walkways due to slip hazard from frozen condensate; or;
  - b. near soffit vents or crawl space vents or other areas where condensate or vapor could create a nuisance or hazard or cause property damage; or;
  - c. where condensate vapor could cause damage or could be detrimental to the operation of regulators, relief valves, or other equipment.
3. Terminate vent at least 3 ft. (915 mm) above any forced air inlet located within 10 ft. (3 m).
4. Vent must terminate at least 4 ft. (1.2 m) horizontally, and in no case above or below unless 4 ft. (1.2 m) horizontal distance is maintained, from electric meters, gas meters, regulators, and relief equipment.
5. Terminate vent at least 6 ft. (1.8 m) away from adjacent walls.
6. DO NOT terminate vent closer than 5 ft. (1.5 m) below roof overhang.
7. The vent terminal requires a 1 ft. (305 mm) vent terminal clearance from the wall.
8. Terminate vent at least 1 ft. (305 mm) above grade, including normal snow line.
9. Multiple direct-vent installations require a 4 ft. (1.2 m) clearance between the ends of vent caps located on the same horizontal plane.

**⚠ WARNING:** The Commonwealth of Massachusetts requires that sidewall-vented heaters, installed in every dwelling, building or structure used in whole or in part for residential purposes, be installed using special provisions as outlined on page 73 of this manual.

The following information is related to SS and Centrotherm InnoFlue Polypropylene venting materials. See **Table T** and **Table U** for appropriate adapters.

Any horizontal sections of a vent must have an upward slope of not less than 1/4" per linear foot from the heater to the vent terminal. The horizontal portions of the vent shall also be supported for the design and weight of the material employed to maintain clearances and to prevent physical damage or separation of joints.

**NOTE:** For extractor sizing, typical CO2 levels are 8.6% for natural gas and 10.0% for propane gas and a flue temperature of 150°F (65°C), at 100% firing rate, 40°F ΔT and a return temperature of 120°F (49°C) measured at the test port, near the flue collar.

**Termination**

The vent terminal must be vertical and must terminate outside the building at least 2 ft. (0.6 m) above the highest point of the roof that is within 8 ft. (2.4 m). The vent cap must have a minimum clearance of 4 ft. (1.2 m) horizontally from and in no case above or below (unless a 4 ft. [1.2 m] horizontal distance is maintained) electric meters, gas meters, regulators and relief equipment.

The distance of the vent terminal from adjacent buildings, open windows and building openings must comply with the NFGC (U.S.) or B149.1 (Canada). Gas vents supported only by flashing and extended above the roof more than 5 ft. (1.5 m) should be securely guyed or braced to withstand snow and wind loads.

**CAUTION:** A listed vent cap terminal suitable for connection to the Cat IV vent materials in **Table T** and **Table U**, adequately sized, must be used to evacuate the flue products from the building.

**WARNING:** Vent connectors serving any other appliances shall not be connected into any portion of mechanical draft systems operating under a positive pressure. If a heater is installed to replace an existing heater, the vent system **MUST** be verified to be of the correct size and of Category IV UL-Listed stainless steel vent material construction or other approved vent materials noted in **Table U**. If it is **NOT**, it **MUST** be replaced.

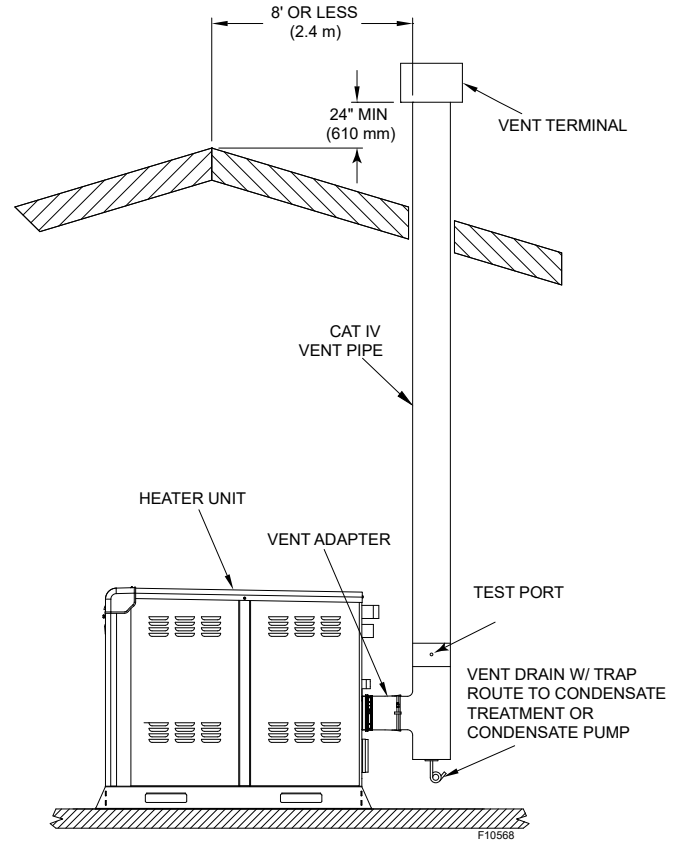

Figure 32. Vertical Venting for Stainless Steel and Polypropylene

| Heater Size | Certified Vent Material*   | Vent Size in. (mm) | Total Vent Length (eq. ft.)** (m) |          | Combustion Air Intake Pipe Material | Air Inlet Max Length** (eq. ft.) (m) |          |
|-------------|--|--------------------|-----------------------------------|----------|-------------------------------------|--------------------------------------|----------|
|             |  |                    | Min.                              | Max.     |                                     | 4" Ø                                 | 6" Ø     |
| 300         | SS Cat IV (UL-Listed), Polypropylene, PVC/CPVC<br>ANSI/ASTM D1785 Sch 40 PVC, ANSI ASTM F441 Sch 40 CPVC | 4 (100)            | 5 (1.5)                           | 100 (30) | Galvanized Steel, PVC, CPVC, ABS    | 100 (30)                             |          |
| 400         |  |                    |                                   |          |                                     |                                      |          |
| 500         |  | 6 (150)            | 5 (1.5)                           | 100 (30) |                                     |                                      | 100 (30) |
| 800         |  |                    |                                   |          |                                     |                                      |          |
| 1000        |  |                    |                                   |          |                                     |                                      |          |

\* Special vent materials are still required.  
\*\* Subtract 10 ft. (3 m) per elbow. Max. 4 elbows.

**NOTE:** Units ship PVC-ready, no adapters required. An adapter will be required when venting with either polypro or stainless steel flue.



**APPROVED**

| Heater Size | Vent Size in. (mm) | Vent Pressure (in. WC) | Volume of Flue Products (CFM) |
|-------------|--------------------|------------------------|-------------------------------|
| 300         | 4<br>(100)         | 0 to 0.2               | 90                            |
| 400         |                    |                        | 120                           |
| 500         |                    |                        | 150                           |
| 650         | 6<br>(150)         |                        | 195                           |
| 800         |                    |                        | 240                           |
| 1000        |                    | 300                    |                               |

\* NOTE: Data for 100% with range between min/max vent length.

**Table W. Typical Vent Pressure and Volume of Flue Products - Stainless Steel and Polypropylene**

## Stainless Steel and Polypropylene - Direct Vent-Vertical

### Installation

These installations utilize the heater-mounted blower to draw combustion air from outdoors and vent combustion products to the outdoors.

The total length of air supply pipe cannot exceed the distances listed in **Table V**. Each elbow used is equal to 10' (3 m) of straight pipe. This will allow installation in any arrangement that does not exceed the lengths shown in **Table V**.

The vent cap is not considered in the overall length of the venting system. See **Table T** and **Table U** for appropriate adapters.

**CAUTION:** This venting system may require the installation of condensate drains in the vent piping per the vent manufacturer's instructions. Failure to install these condensate drains in the venting system may cause a non-warrantable failure.

Care must be taken during assembly that all joints are sealed properly and are airtight.

The vent must be installed to prevent the potential accumulation of condensate in the vent pipes. It is required that:

1. The vent must be installed with a condensate drain located in proximity to the heater as directed by the vent manufacturer.
2. The vent must be installed with a slight upward slope of at least 1/4" per foot of horizontal run to the vent terminal.

### Termination

The vent cap **MUST** be mounted on the exterior of the building. The vent cap cannot be installed in a well or below grade. The vent cap must be installed at least 1' (305 mm) above ground level and above normal snow levels.

The vent cap **MUST NOT** be installed with any combustion air inlet directly above a vent cap. This vertical spacing would allow the flue products from the vent cap to be pulled into the combustion air intake installed above.

This type of installation can cause non-warrantable problems with components and poor operation of the heater due to the recirculation of flue products. Multiple vent caps installed in the same horizontal plane must have at least 4" (100 mm) clearance from the side of one vent cap to the side of the adjacent vent cap(s).

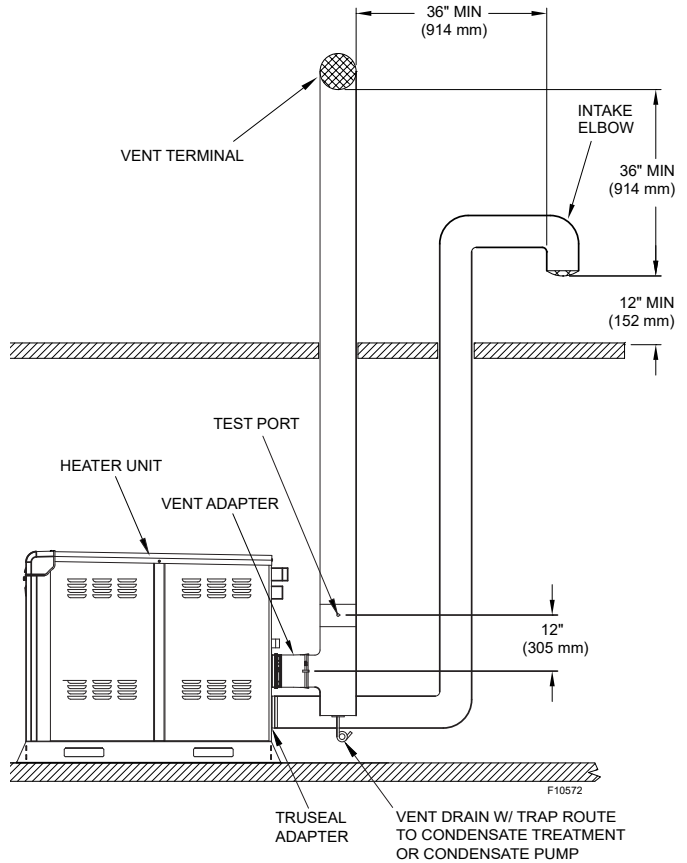

**Figure 33. Direct Vent-Vertical for Stainless Steel and Polypropylene**

**NOTE:** While a condensate drain connection for the vent system is required on all heater installations, the drain can be accomplished in several different ways. The figures in this section show the drain from the heat exchanger, however, this can also be accomplished using an additional inline collector for condensing stacks or an additional inline vertical or horizontal collector available from several of the listed vent manufacturers.

Combustion air supplied from outdoors must be free of particulate and chemical contaminants. To avoid a blocked flue condition, keep the vent cap clear of snow, ice, leaves, debris, etc.

The approved flue direct vent cap must be installed in accordance with its listing. See **Table T** and **Table U**.

**⚠ WARNING:** Mixing of different manufacturers venting material is not permitted as this may create an unsafe condition.

**⚠ CAUTION:** This venting system may require the installation of supplemental condensate drains in the vent piping per the vent manufacturer's instructions. Failure to install these condensate drains in the venting system may cause a non-warrantable failure.

## Stainless Steel and Polypropylene - Horizontal Through-the-Wall and Direct Vent - Horizontal

The heaters may be vented horizontally (either using room air for combustion or ducted air for combustion) as shown in the following figures. The air intake terminal may be located in a different pressure zone (i.e. on different walls) from the vent termination. See **Figure 35**.

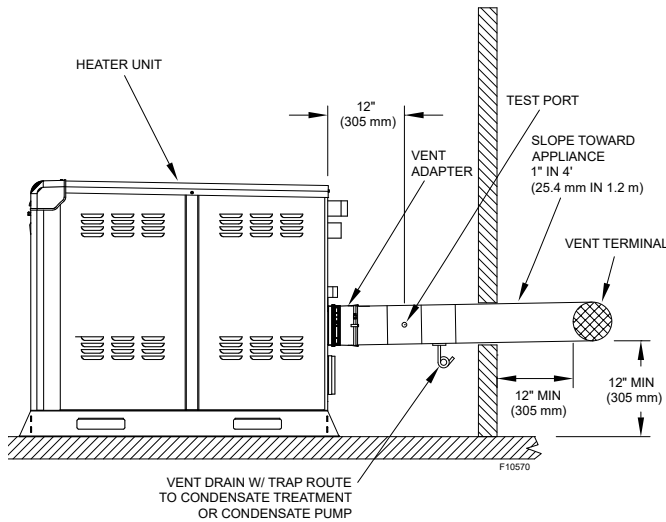

**Figure 34. Horizontal Through-the-Wall Venting for Stainless Steel and Polypropylene**

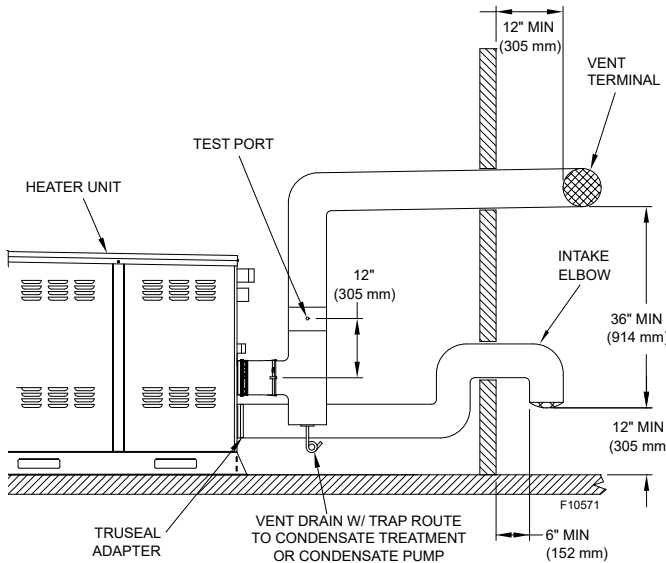

**Figure 35. Direct Vent-Horizontal for Stainless Steel and Polypropylene**

## Installation

These installations utilize the heater-mounted blower to vent the combustion products to the outdoors. Combustion air is taken from inside the room or directly from outdoors and the vent is installed horizontally through the wall to the outdoors. Adequate combustion and ventilation air must be supplied to the equipment room in accordance with the NFGC (U.S.) or B149.1 (Canada). For combustion air in different pressure zones, see **Figure 36**.

The total length of the horizontal through-the-wall flue system should not exceed the maximum equivalent ft in length. See **Table V** for maximum length. If horizontal run exceeds the maximum equivalent ft, an appropriately sized variable-speed extractor must be used. Each elbow used is equal to 10 ft. (3 m) of straight pipe. This will allow installation in one of the four following arrangements (example shown for Model 1006 with 6" vent):

- 100 ft. (30 m) of straight flue pipe
- 90 ft. (27 m) of straight flue pipe and one elbow
- 80 ft. (24 m) of straight flue pipe and two elbows
- 70 ft. (21 m) of straight pipe and three elbows

The vent cap is not considered in the overall length of the venting system.

The vent must be installed to prevent flue gas leakage. Care must be taken during assembly to ensure that all joints are sealed properly and are airtight. The vent must be installed to prevent the potential accumulation of condensate in the vent pipes. It is required that:

3. The vent must be installed with a condensate drain located in proximity to the heater as directed by the vent manufacturer.
4. The vent must be installed with a slight upward slope of not less than 1/4" per foot of horizontal run to the vent terminal.

## Termination

The flue direct vent cap **MUST** be mounted on the exterior of the building. The direct vent cap cannot be installed in a well or below grade. The direct vent cap must be installed at least 1 ft. (305 mm) above ground level and above normal snow levels. The factory approved horizontal, stainless steel flue direct vent cap must be used (see **Table T** and **Table U**). The vent terminal must be located **NO CLOSER** than 12" (305 mm) off the wall.

**⚠ WARNING: Mixing of different manufacturers venting material is not permitted as this may create an unsafe condition.**

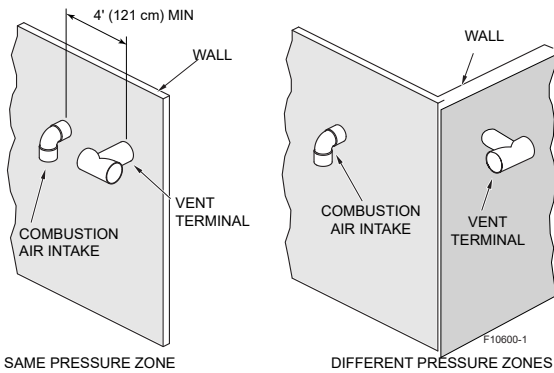

Figure 36. Air Intake Location

## PVC/CPVC - Vertical Venting (Cat IV)

### Installation

No vent adapter is required when venting the heater with PVC. The maximum and minimum venting length for this heater is shown in **Table V**.

Any horizontal sections of a vent must have an upward slope of at least 1/4" per linear foot from the heater to the vent terminal. The horizontal portions of the vent shall also be supported for the design and weight of the material employed to maintain clearances and to prevent physical damage or separation of joints.

A condensate trap and drain are required at the bottom of the PVC/CPVC tee as shown in **Figure 37**.

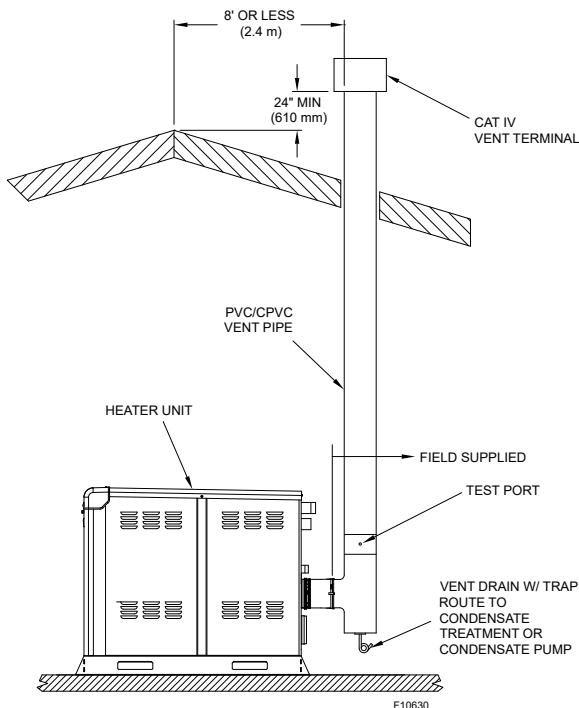

Figure 37. Vertical Venting for PVC/CPVC

### Termination

The vent terminal must be vertical and must terminate outside the building at least 2 ft. (0.6 m) above the highest point of the roof that is within 8 ft. (2.4 m). The vent cap should have a minimum clearance of 4 ft. (1.2 m) horizontally from and in no case above or below (unless a 4 ft. [1.2 m] horizontal distance is maintained) electric meters, gas meters, regulators and relief equipment.

The distance of the vent terminal from adjacent buildings, open windows and building openings must comply with the NFGC (U.S.) or B149.1 (Canada). Gas vents supported only by flashing and extended above the roof more than 5 ft. (1.5 m) should be securely guyed or braced to withstand snow and wind loads.

**⚠ CAUTION: A vent cap tee suitable for connection to the Cat IV PVC/CPVC vent materials, must be used to evacuate the flue products from the building.**

**⚠ WARNING: Vent connectors serving any other appliances shall not be connected into any portion of mechanical draft systems operating under a positive pressure. If a heater is installed to replace an existing heater, the vent system MUST be verified to be of the correct size and of Category IV vent material construction or other approved vent materials. If it is NOT, it MUST be replaced.**

**NOTE: For extractor sizing, typical CO<sub>2</sub> levels are 9.0% for natural gas and 10.3% for propane gas and flue temperature of 150°F (65°C), at 100% firing rate, 40°F ΔT and return temperature of 120°F (49°C) measured at the test port, near the flue collar.**

### PVC/CPVC - Direct Vent - Vertical

**NOTE: Use only certified vent material ANSI/ASTM D1785 Sch 40 PVC, ANSI ASTM F441 Sch 40 CPVC.**

### Installation

These installations utilize the heater-mounted blower to draw combustion air from outdoors and vent combustion products to the outdoors.

The total length of air supply pipe cannot exceed the distances listed in **Table V**. Each elbow used is equal to 10 ft. (3 m) of straight pipe. This will allow installation in any arrangement that does not exceed the lengths shown in **Table V**.

**⚠ CAUTION: This venting system requires the installation of condensate drains in the vent piping per the vent as shown in Figure 38. Failure to install these condensate drains in the venting system may cause a non-warrantable failure.**





## APPROVED

The vent must be installed with a condensate drain located in proximity to the heater as directed by the vent manufacturer.

- The vent must be installed with a slight upward slope of not less than 1/4" per foot of horizontal run to the vent terminal.

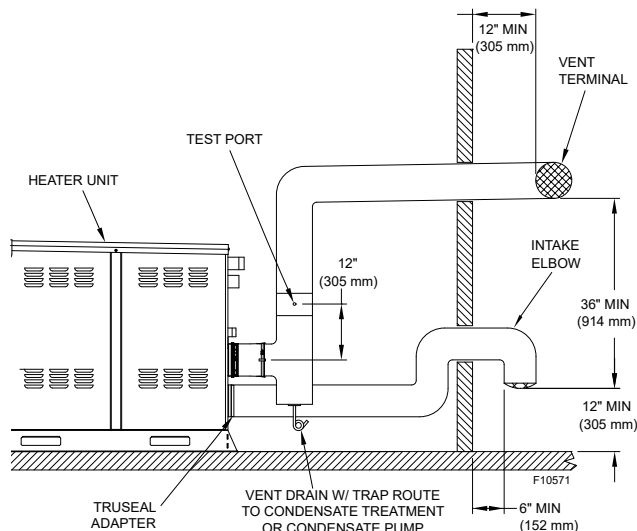

Figure 40. Direct Vent-Horizontal for PVC/CPVC

**CAUTION:** This venting system requires the installation of condensate drains in the vent piping as shown in Figure 39 or Figure 40. Failure to install these condensate drains in the venting system may cause a non-warrantable failure.

## Installation

These installations utilize the heater-mounted blower to vent the combustion products to the outdoors. Combustion air is taken from inside the room or directly from the outdoors and the vent is installed horizontally through the wall to the outdoors. Adequate combustion and ventilation air must be supplied to the equipment room in accordance with the NFGC (U.S.) or B149.1 (Canada).

A condensate trap and drain are required at the bottom of the PVC/CPVC tee as shown in Figure 39 and Figure 40.

The total length of the horizontal through-the-wall flue system should not exceed the maximum equivalent ft in length. See Table V for maximum length. If horizontal run exceeds the maximum equivalent ft, an appropriately-sized variable-speed extractor must be used. Each elbow used is equal to 10 ft. (3 m) of straight pipe. This will allow installation in one of the four following arrangements:

- 100 ft. (30 m) of straight flue pipe
- 90 ft. (27 m) of straight flue pipe and one elbow
- 80 ft. (24 m) of straight flue pipe and two elbows
- 70 ft. (21 m) of straight flue pipe and three elbows

The vent cap is not considered in the overall length of the venting system.

The vent must be installed to prevent flue gas leakage. Care must be taken during assembly to ensure that all joints are sealed properly and are airtight. The vent must be installed to prevent the potential accumulation of condensate in the vent pipes. It is required that:

## Termination

The vent cap **MUST** be mounted on the exterior of the building. The vent cap cannot be installed in a well or below grade. The vent cap must be installed at least 12" (305 mm) above ground level and above normal snow levels. The approved horizontal, PVC/CPVC vent cap that must be used is a Tee of the same size as vent pipe. See Figure 39 and Figure 40. The vent terminal must be located **NO CLOSER** than 12" (305 mm) off the wall.

## Outdoor Installation

Heaters must not be installed outdoors in freezing climates. Heaters installed outdoors must be vented with listed UV-resistant vent material per the following instructions and installed with the factory-supplied stainless steel Outdoor Vent Kit. See Table X. A special vent cap is provided in accordance with CSA requirements. This must be installed directly on the vent pipe as illustrated in Figure 41.

| Heater Size | Outdoor Kit No.                                |
|-------------|--|
| 300 - 500   | 4" Kit available. Consult factory for details. |
| 650 - 1000  | 6" Kit available. Consult factory for details. |

Table X. Outdoor Vent Kits

**NOTE:** External support of outdoor venting is required if the vent extends beyond the jacket top by more than 36" (914 mm).

The flue outlet is not designed to support the weight of the vent system beyond 36" (914 mm) above the jacket top. Supplemental support is required if the vent extend beyond 36" (914 mm).

The factory Outdoor Vent Kits contain the following components:

- SS Adapter
- SS Elbow
- 36 in. Straight SS Vent
- Termination Tee
- Installation Instructions

Care must be taken when locating the heater outdoors, because the flue gases discharged from the vent cap can condense as they leave the cap. Improper location can result in damage to adjacent structures or building finish.

**APPROVED**

For maximum efficiency and safety, the following precautions must be observed:

1. When heaters are installed outdoors, they must use the Outdoor Vent Kit that is available from the factory. Follow instructions provided with kit for installation.
2. Periodically check venting system. The heater's venting areas must never be obstructed in any way and minimum clearances must be observed to prevent restriction of combustion and ventilation air. See **Table I**. Keep area clear and free of combustible and flammable materials.
3. Do not locate adjacent to any window, door, walkway, or gravity air intake. The vent must be located a minimum of 4 ft. (1.2 m) horizontally from such areas.

**NOTE: Condensate can freeze on the vent cap. Frozen condensate on the vent cap can result in a blocked flue condition.**

4. Install above grade level.
5. Vent terminal must be at least 3 ft. (914 mm) above any forced air inlet located within 10 ft. (3 m).
6. Adjacent brick or masonry surfaces should be protected with a rust-resistant sheet metal plate to prevent staining/corrosion of the wall surfaces.

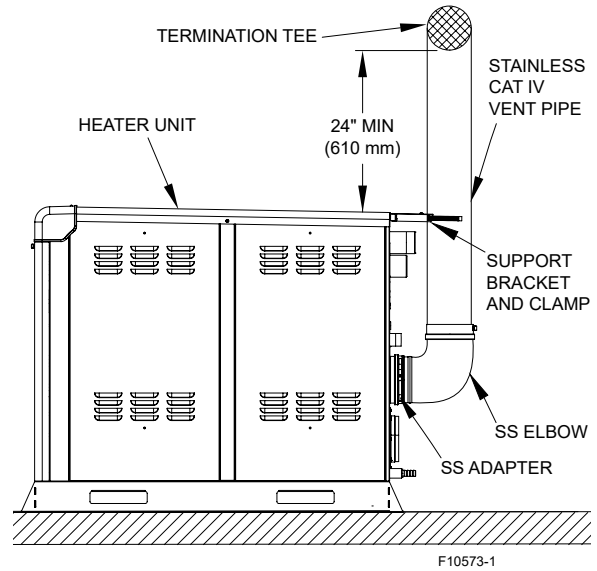

Figure 41. Outdoor Installation

### Common Venting

The NFGC does not address sizing guidelines for the common venting of multiple Category IV heaters. This is covered in the NFGC under "Engineered Vent Systems". **Table W** provides heater discharge vent pressures at vent pressure switch and volumes of flue products at full fire for the calculation of appropriate vent and extractor sizing for common venting.

Factory does not support common venting under positive-pressure conditions. Use an external variable-speed extractor to draw the stack to negative pressure. See **Figure 42**. Interlock the extractor to each connected heater at terminals #17 and #18 (See **Figure 28**) to ensure that no connected heaters will fire until the extractor is proven operational.

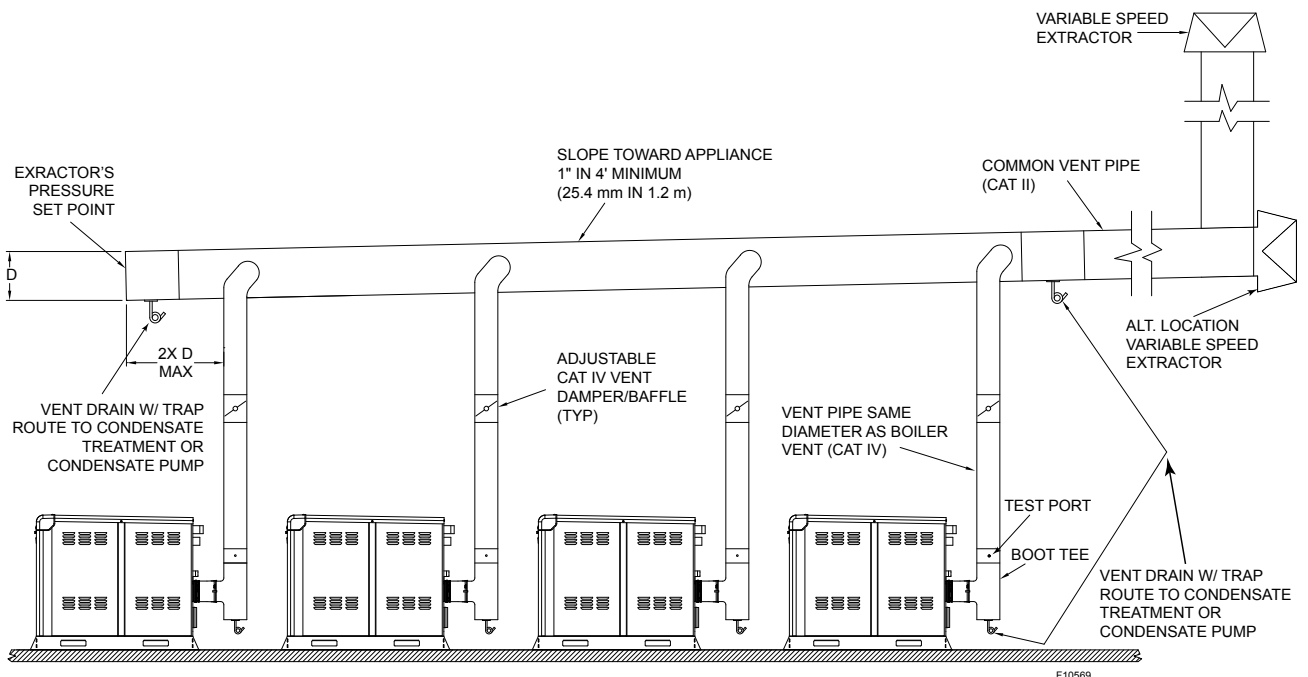

Figure 42. Typical Common Venting  
UNCONTROLLED DOCUMENT IF PRINTED

APPROVED

Figure 43 is a visual guide only. Follow the factory instructions for the installation of the Condensate Treatment Kit and condensate drains.

## Condensate Treatment

The condensate must be drained properly to protect the appliance and drainage system. The condensate from the heater condensate drain is acidic. Its pH is typically between 3.2 and 4.5.

The factory-installed Condensate Treatment Kit is connected to the condensate drain of the heater contains treatment media to raise the pH level of the condensate.

The pH of the effluent entering a sanitary drain must be 5.0 or higher.

**CAUTION:** In general, the condensate piping from the appliance must have a downward slope of 1/4" per horizontal foot. Condensate drain traps must be primed with water to prevent gas flue leaks. Treatment kits should be checked at least once per year. To ensure the pH of the effluent is 5.0 or higher, the media should be replenished as necessary. When replacing the media, the drain lines should be no smaller than 3/4" to avoid blockage in the condensate piping.

**WARNING:** Do not install the heater outdoors if freezing conditions are typical. The condensate will freeze and back up the flue system.

**CAUTION:** Condensate drain lines must not be allowed to freeze. Take appropriate measures.

Vent pipe condensate drains are also required for installation of the heater when using PVC or CPVC. Follow instructions for location of condensate drains in the vent.

## Freeze Protection

To enable freeze protection, DIP switch position 7 (on the PIM) must be turned on (UP position). This is the default position.

If the water temperature drops below 45°F (7°C) on the Outlet or Inlet sensors, the heater pump/isolation valve is enabled. The heater pump is turned off/isolation valve closed when both the Inlet and Outlet temperatures rise above 50°F (10°C).

If either the Outlet or Inlet temperature drops below 38°F (3°C), the VERSA starts the burner at the minimum firing rate. The burner cycle will terminate when both the Inlet and Outlet temperatures rise above 42°F (6°C).

**NOTE:** Failure of the optional flow meter, if present, will not initiate a heating cycle if temperatures drop below 38°F (3°C).

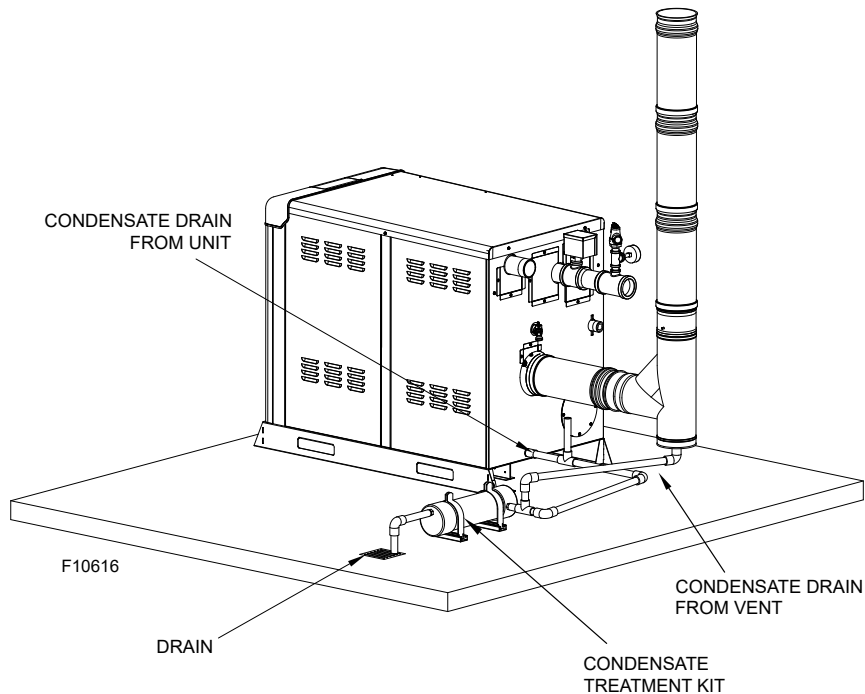

Figure 43. Visual Guide for Condensate Piping

UNCONTROLLED DOCUMENT IF PRINTED

## 5. CONTROLS

### Sequence of Operation

1. Upon initial application of 24VAC power, by toggling the rocker switch to the "IDLE" position the PIM resets with all outputs in the "OFF" state.
2. Enabling the unit by toggling the third position (RUN) of the rocker switch, allows the PIM and VERSA IC<sup>®</sup> to perform a processor and memory self-test to ensure proper operation.
3. The PIM confirms the presence of a valid ID card which matches the configuration stored in memory at the factory. If a valid ID card is NOT present, the PIM generates a diagnostic fault (ID Card Fault) and will shut down waiting for this fault to be addressed.
4. The PIM reads the DIP switch settings and configures itself for the desired operation. PIM DIP 3 = OFF indicates primary-only pipe configuration, which uses an Isolation valve, while PIM DIP 3 = ON means primary / secondary and uses a heater pump.
5. The PIM scans the Ft\_bus communications for the VERSA board and if found, system operation is controlled by the VERSA board. If the PIM does not find the VERSA board, it will enter "limp-along" mode. See Section 11 of the VERSA IC<sup>®</sup> Manual (241493).
6. Non-volatile memory is checked for any active lockout conditions. If any exist, they must be addressed before the PIM will allow a new trial for ignition to start.
7. The PIM continually monitors the flame status to ensure that no flame is present during standby. If an erroneous flame is detected, the PIM generates a False Flame error fault.
8. The PIM verifies that the vent sensor is below the vent limit temperature before burner operation. The control uses the input from this sensor to automatically reduce firing rate should the vent temperature approach the vent material temperature limits. If the vent temperature is exceeded, the PIM performs a Post-purge and proceeds to a hard lockout (manual-reset).
9. A call-for-heat is initiated by the presence of any one or more of the sources below. See **Figure 28**.
  - a. A heat demand (contact closure) on the Enable/Disable field wiring terminals (#11 and #12)
  - b. A voltage greater than 1.0 VDC on the analog 0-10 VDC EMS signal input (#13 and #14)
  - c. A heat demand present on the indirect DHW field wiring terminals (#4 and #5)
  - d. A heat demand from the VERSA board based on the DHW sensor temperature
10. The PIM initiates a trial for ignition (TFI) counter to the programmed number of trials for ignition (1 or 3) and proceeds to Pump Purge mode.
11. The VERSA board will turn on the heater pump and/or keep the Isolation Valve open, turn on the system, and/or DHW pump as necessary to address the call-for-heat. This is dependent on the Mode of operation selected and the PIM DIP #3 position. The heater will proceed through its pre-purge period before the control will move into a Trial for Ignition.

**Steps 12 and 13 are applicable if a flow meter (sales order option F-1) is installed:**

12. The PIM will only allow for ignition as long as the flow meter detects a flow higher than the minimum flow requirement for the unit. If minimum flow is not achieved within 90 seconds, the unit will broadcast a "Flow Error" condition and will hold from ignition until proper flow is observed.
  - a. An alarm will notify the user that the unit did not ignite due to insufficient flow.
  - b. If sufficient flow is present at the flow meter and can be verified by the user, it is assumed that the flow meter needs to be serviced. Under this situation the user can override the Flow Error and allow ignition and select an allowable firing rate up to 80%. NOTE: Flow Override will expire after 24 hours. Once time has expired, the unit will cycle and alarm will turn back on. If the unit cycles power within the 24-hour period, the Flow Override expiration time will be reset.
13. If the flow meter detects flow equal to or higher than the minimum flow requirement, then the unit is allowed to proceed to the trial for ignition.

14. The PIM will only allow for ignition as long as the flow meter detects a flow higher than the minimum flow requirement for the unit. If minimum flow is not achieved within 90 seconds, the unit will broadcast a "Flow Error" condition and will hold from ignition until proper flow is observed.
  - a. An alarm will notify the user that the unit did not ignite due to insufficient flow.
  - b. If sufficient flow is present at the flow meter and can be verified by the user, it is assumed that the flow meter needs to be serviced. Under this situation the user can override the Flow Error and allow ignition and select an allowable firing rate up to 80%. NOTE: Flow Override will expire after 24 hours. Once time has expired, the unit will cycle and alarm will turn back on. If the unit cycles power within the 24-hour period, the Flow Override expiration time will be reset.



## APPROVED

15. If the flow meter detects flow equal to or higher than the minimum flow requirement, then the unit is allowed to proceed to the trial for ignition.
16. The VERSA board and PIM check the safety circuit and will prevent a trial for ignition if any of the safety devices are in an error/fault condition.
17. The blower is energized and set to pre-purge speed.
18. Once the blower speed is acknowledged as operating at the prepurge speed by the tachometer output, the blower proceeds to pre-purge for the specified duration.
19. The secondary voltage level of the 24VAC supply input is confirmed to be above 18VAC – if not, a Low Voltage fault will be recorded and the heater will shut off until the voltage rises above 18VAC consistently.
20. If all checks have passed, the system proceeds to ignition.
21. The PIM re-initializes the ignition counter to the configured number of trials (1 or 3).
22. The Hi Limit sensor is confirmed to read below the Hi Limit setpoint.
23. The blower light-off RPM speed is verified.
24. The gas valve relay contacts are verified open – if closed, a fault code will be issued and the heater will post-purge and go into a hard lockout condition.
25. The heater is equipped with direct spark igniter (DSI):
  - a. The control turns on the DSI and the DSI proving current is verified to be above the threshold value (3.2A reference).
  - b. The configured heat-up delay takes place to allow the DSI element to reach ignition temperature.
  - c. The gas valve output is energized for the trial for-ignition time to light the burner.
  - d. The DSI is de-energized during the last second of the trial-for-ignition period to sense for the burner flame.
  - e. The flame sense is checked for successful lighting of the burner. If a valid flame is detected, the main gas valve, operating pumps and blower relay remain energized and the PIM proceeds to the Heating mode.
26. If flame is not detected during the trial-for-ignition period, the gas valve output is disabled immediately and the blower goes to a post-purge.
27. On single trial-for-ignition models, the PIM enters ignition lockout and the LED on the PIM indicates the fault code for ignition lockout. The VERSA IC<sup>®</sup> Display should also state Ignition Lockout. To reestablish operation after the post purge has been completed and clear the lockout error, press the reset button.
28. On multi-trial-for-ignition models, the control goes through an inter-purge delay before additional ignition attempts are started. If no flame is detected after the final trial-for-ignition, the PIM enters ignition lockout and the LED on the PIM indicates the fault code for ignition lockout. The VERSA IC<sup>®</sup> Display should also state Ignition Lockout. To reestablish operation after the post purge has been completed and clear lockout error, press the reset button.
29. When the unit is firing, the firing rate of the unit is always governed by the amount of flow sensed through the heat exchanger, and Delta T. The less flow, the less maximum allowable firing rate. However the system will still modulate based on target and supply temperature, EMS signal or Modbus Rate modes between min firing rate and maximum allowable firing rate according with the water flow across the heat exchanger.

## VERSA Integrated Control

The heater is equipped with a sophisticated set of software rules intended to protect the integrity of the equipment and at the same time guarantee the most efficient operational point of the heater.

These software rules will prevent the heater from cycling excessively, avoiding unnecessary stress on the combustion chamber elements. Additionally, the VERSA integrated control is able to anticipate required maintenance of internal parts, and diagnose common application problems that could lead to deterioration of the heater, such as sudden loss of flow, overshoot of supply temperature, excessive temperature on flue pipe, and outlet water temperature spikes, among others.

## Flow Meter (Sales Order Option F-15)

The Flow meter, located on the inlet pipe, acts a governor for the heater, and depending on the flow reading, the control allows the heater to operate up to a calculated maximum firing rate as a function of the flow rate observed. In spite of calculated maximum allowable firing rate of the unit, the system will still modulate to achieve target or obey an external rate command. See **Figure 44**.

## Flow Override (If flow meter is installed)

In the unlikely event that the flow meter reading is compromised, due to several possible external factors, the user is able to override the minimum flow requirement and permit ignition of the unit.

**⚠ CAUTION: Sufficient water flow has to be confirmed before enabling the flow override function. Severe heat exchanger damage could occur if there is insufficient flow across the heat exchanger during operation.**



## APPROVED

The flow override setting will only become visible when the heater is alarming due to an unsuccessful call-for-heat as a result of insufficient flow detection. The setting can be found under Adjust Setting within the System Settings section.

When the "Flow Override" is activated, the user is able to select the maximum firing rate at which the heater can operate. The system will still modulate up to this maximum firing rate to achieve target. The maximum firing rate is defined by the user between minimum firing rate of the unit up to 80%. The Flow Override function has an expiration time of 24 hours, and must be manually reactivated for the unit to continue operation under such conditions.

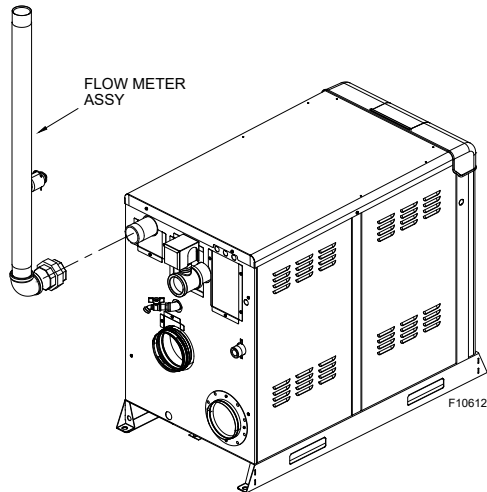

Figure 44. Flow Meter

### Under Flow Error (If a flow meter is installed)

"Under Flow Error" is only possible when the heater is already firing. It is considered an Under Flow Error when the flow reading drops below the operational criteria for the heater, or is totally lost during an active heat demand.

In this scenario, the heater will broadcast an error and alarm. However, it will not stop providing heat. Instead the unit automatically reduces firing rate to minimum firing rate. If flow is indeed null or low, the heater has other protection algorithms such as Outlet Max, and Max Delta T Protection, which will shut down the heater if these values are exceeded.

### Cascade Flow Offset (If a flow meter is installed)

In a cascade configuration, the master heater will only allow the next unit in the cascade to operate when the observed flow is double the minimum flow requirement of the next unit in the cascade. This is to overcome any pressure drop when enabling the second heater. It is expected that the flow will drop significantly when the isolation valve of the next heater in the cascade is opened.

Because pressure drop may vary depending on several specific conditions of each job site, the Cascade Flow Offset provides the ability to fine tune the minimum flow requirement in a cascade configuration. Adjusting the Cascade Flow Offset will affect the call of the next unit in the cascade (speed up or delay the call). This setting is located within the Adjustment Menu in system settings. The default value is "0" with range of -25 gpm to +15 gpm (-95 lpm to +57 lpm).

**Example:** If the cascade consists of 3 heaters where each heater has a MIN flow condition of 40 gpm (151 lpm), and the Cascade Flow Offset value is "0" (factory default), the master heater requires seeing a minimum 80 gpm (302 lpm) before attempting to open the second heater insulation valve (upon a continued call-for-heat). Adjusting the Cascade Flow Offset value to "-5" results in the master heater seeing a minimum flow equal to  $[40 - 5 = 35 \text{ gpm}]$  (132 lpm) for each heater or 70 gpm (264 lpm) total before attempting to open the second heater isolation valve.

The following functions of the VERSA IC<sup>®</sup> are applicable only if a flow meter is installed.

#### $\Delta T$ Protection Zones

The  $\Delta T$  Protection Zones are a function of the VERSA IC<sup>®</sup> which monitors flow, firing rate, and anticipated  $\Delta T$  based on the type of fluid (water or water/glycol concentration) being heated to determine if the heater is functioning properly.

The heater includes multiple checks to ensure the safe performance of the unit. If the flow meter reading is determined to be inaccurate, the unit will still find the optimum point of operation based on the  $\Delta T$ . If heater flow is indeed below what is being reported by the sensor, the  $\Delta T$  will increase in proportion to the flow discrepancy.

The heater will adjust firing rates using dynamic thresholds called " $\Delta T$  zones". These zones are (1) Flow Warning Zone, (2) Hold Firing Rate Zone, and (3) Min Firing Rate Zone, described in the following sections.

#### Flow Warning Zone

The Flow Warning Zone is considered a warning. The service light will flash, no alarm will be triggered, and a warning error will be broadcast and recorded. The flow warning indicates that the  $\Delta T$  is higher than the expected value given a specific flow and firing rate.

The Flow Warning Zone operates in conjunction with the user-defined  $\Delta T$  Offset – see Troubleshooting, **Section 9** for more details. If the  $\Delta T$  continues to increase and exceeds the Flow Warning Zone, the heater will enter the Hold Firing Rate Zone.

### Hold Firing Rate Zone

In the Hold Firing Rate Zone, the control will hold modulation regardless of the flow reading. The firing rate will be held at the current firing rate in an attempt to prevent the  $\Delta T$  from increasing further. If the  $\Delta T$  drops below this zone, heater operation will release to PID control. If the  $\Delta T$  continues to increase, the control will enter the Min Firing Rate Zone.

### Min. Firing Rate Zone

If all other attempts to prevent the  $\Delta T$  from increasing fail, the firing rate will drop to minimum firing rate as a last attempt to prevent a  $\Delta T$  fault. If this action is effective, the  $\Delta T$  will drop and the heater will attempt to find the optimum point of operation. However, if this action is not successful and the  $\Delta T$  continues to climb, and the MAX  $\Delta T$  threshold is exceeded, and the burner is forced to cycle.

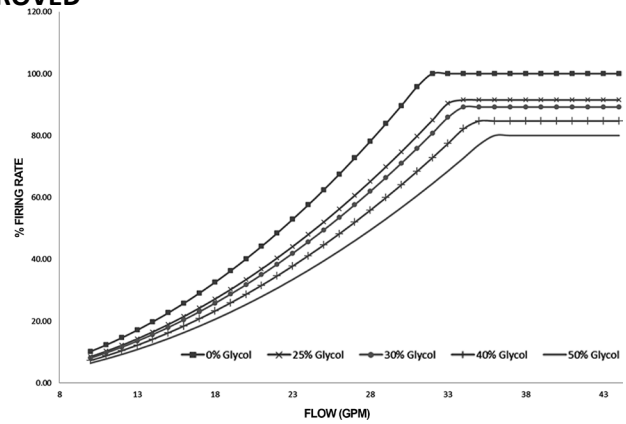

Figure 45. Glycol Operation Chart

### Glycol % Setting

The heater is equipped with algorithms that will ensure optimum operation when using different glycol concentrations as the heat media. From the VERSA IC<sup>®</sup> touchscreen, the user must select a glycol concentration.

This setting can be found within the Adjust Menu within System Settings.

**NOTE:** The factory default value is 50% glycol concentration. Restoring factory defaults WILL NOT reset this value.

When replacing the VERSA IC<sup>®</sup>, it is important to update the glycol percentage value as needed for proper system operation.

| Heater Size | Max Firing Rate % | 100                                     | 91.49 | 89.19 | 84.68 | 79.67 |
|-------------|-------------------|---|-------|-------|-------|-------|
|             | Glycol %          | 0%                                      | 25%   | 30%   | 40%   | 50%   |
|             | Input (BTUH)      | Min Flow GPM @ Max DT @ Max Firing Rate |       |       |       |       |
| 300         | 300,000           | 14.40                                   | 15.30 | 15.60 | 16.20 | 17.10 |
| 400         | 399,000           | 19.20                                   | 20.10 | 20.40 | 21.00 | 21.60 |
| 500         | 500,000           | 24.30                                   | 25.50 | 26.10 | 27.00 | 28.50 |
| 650         | 650,000           | 31.20                                   | 33.30 | 34.20 | 35.40 | 37.20 |
| 800         | 800,000           | 38.70                                   | 41.40 | 42.30 | 44.10 | 46.80 |
| 1000        | 1,000,000         | 48.30                                   | 51.00 | 52.20 | 54.00 | 56.70 |

Table Y. Performance Changes @ Various Glycol Concentrations

The glycol protection will reduce the maximum firing rate, but will also change the entire heating profile depending on the model size. See Figure 45.

### Vent Protection

The heaters are equipped with a vent temperature sensor located at the rear of the heater. See Figure 4.

The vent protection algorithm will anticipate a flue temperature overshoot and adjust the firing rate of the heater to prevent excessive flue temperatures from occurring.

**NOTE:** The factory default is set to “PVC”.

During commissioning of the heater, the vent material must be selected in the Adjust Menu (Submenu of System Settings) to indicate the vent material installed on the heater.

The settings for the Vent Protection include:

**NOTE:** Use only certified vent material ANSI/ASTM D1785 Sch 40 PVC, ANSI ASTM F441 Sch 40 CPVC.

- Vent Material.**  
 PVC (149°F/65°C),  
 CPVC (194°F/90°C),  
 PPS (Polypropylene) (230°F/110°C),  
 Stainless Steel (AL29-4C)
- Vent Differential.** Subtractive value from max vent temperature that defines when the control will take action to prevent unit from reaching the max vent temperature. Default 10°F (5.6°C) selectable from 1°F (0.6°C) - 20°F (11°C).
- Vent Rate.** This value defines the max firing rate the heater will be allowed to operate at when Vent Protection is active.

If the vent temperature exceeds the allowable limit for the vent material selected, the burner will cycle. This is an automatic reset function and as soon as the vent temperature drops to an acceptable level, the heater will return to normal operation.

**NOTE:** The use of PVC/CPVC will require the user to limit the maximum setpoint of the heater in the Adjust menu.

## Control Devices

**⚠ WARNING:** Installation, adjustment and service of heater controls, including timing of various operating functions, must be performed by a qualified installer, service agency or the gas supplier. Failure to do so may result in control damage, heater malfunction, property damage, personal injury, or death.

**⚠ WARNING:** Turn off the power to the heater before installation, adjustment or service of any heater controls. Failure to do so may result in board damage, heater malfunction, property damage, personal injury, or death.

**⚠ CAUTION:** This appliance has provisions to be connected to more than one supply source. To reduce the risk of electric shock, disconnect all such connections before servicing.

**⚠ CAUTION:** Risk of electric shock: More than one disconnect switch may be required to de-energize the equipment before servicing.

### Motorized Isolation Valve (Sales Order Option P-170)

Refer to **Figure 47**.

The heater is equipped with a relay output to control an isolation valve as follows:

- Heater output energized = Isolation valve CLOSED
- Heater output de-energized = Isolation valve OPEN

The operation above may be manually adjusted by manually inverting the operation of the isolation valve and using the opposite dry contact of the relay output.

24VAC supply voltage for the isolation valve actuation is also available at the rear of the heater in the wiring box, next to the isolation valve relay output.

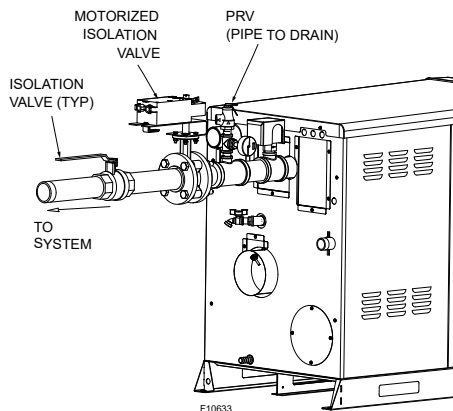

**Figure 46. Motorized Isolation Valve Installation**

**⚠ CAUTION:** Failure to set up the Isolation Valve correctly may damage the heater/system pump causing non-warrantable failures.

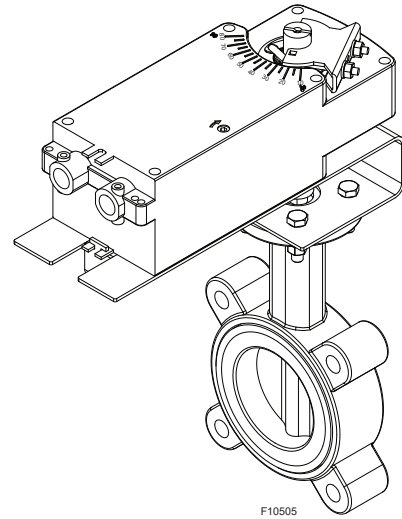

**Figure 47. Motorized Isolation Valve**

### Ignition Control Functions

When there is a call-for-heat, and all safeties are closed and minimum flow rate detected, then the combustion air blower starts to purge air from the combustion chamber. After the pre-purge, the igniter is energized. The standard ignition module will lock-out after failing to light 3 times during a call-for-heat. To reset the lock-out, press and release the RESET button located adjacent the user interface. The control will automatically reset after 1 hour. When in lock-out the control will run the blower through a post-purge cycle.

The single-try ignition module (sales order option C-6) will attempt to light only one time before lock-out occurs. To reset the lock-out, press and release the RESET button located adjacent the user interface.

**Turning off the power to the heater WILL NOT reset the single-try ignition module.**

**NOTE:** Ignition modules are common for all heater model sizes. However, model-specific operating parameters are defined by their respective ID cards.

### 3-Position Rocker Switch

This heater is equipped with a 3-position rocker switch located on the front control panel (adjacent the touchscreen display).

The 3-positions of this switch are:

- Right = OFF
- Middle = IDLE
- Left = RUN

When the switch is in the OFF position, there is power to the control and the heater is not operational.

**⚠ WARNING:** There is still live electricity inside the heater - disconnect electrical supply to the heater before servicing the heater.

When the switch is in the IDLE position, power is supplied to the control to allow for review/adjustment of settings, but the heater will not fire.

**CAUTION:** The Enable/Disable signal may be overridden when the VERSA control is configured for MODBUS "TEMP" or "RATE". Disable MODBUS prior to servicing the heater.

When the switch is in the RUN position, the heater is enabled to operate based on the water temperature and target temperature setpoint.

### High Limit - Manual-Reset

This heater is equipped with a fixed-setting manual-reset high-limit temperature device as standard. It may also have an additional optional adjustable manual-reset high temperature device.

The optional manual-reset high-limit is located inside the cabinet on the upper right corner post. See **Figure 2**.

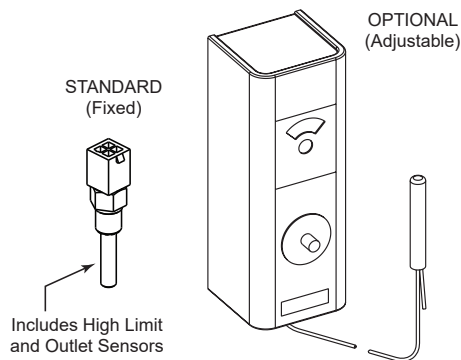

**Figure 48. High Limit (Manual-Reset) (MRHL)**

The fixed-setting manual-reset high-limit is built into the PIM, and utilizes a dual thermistor sensor located on the outlet.

Boilers: 200°F (93°C)

Water Heaters: 180°F (82°C)

To reset a high-limit lock-out, press and release the RESET button located adjacent the user interface or the RESET button located on the face of the optional MRHL.

### High Limit - Auto-Reset (Sales Order Options I-13 for boilers, I-14 for water heaters)

This heater may be equipped with an optional adjustable auto-reset high-limit temperature device.

The optional adjustable auto-reset high-limit is located inside the cabinet on the upper right corner post. See **Figure 2**. Adjust the setting to approx. 20°F (11°C) above desired outlet temperature.

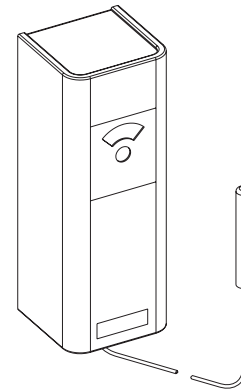
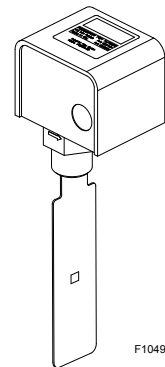

**Figure 49. Adjustable High Limit (Auto-Reset)**

### Flow Switch

This standard, dual-purpose control, mounted and wired in series with the main gas valve, shuts off the heater in case of pump failure or low water flow. See **Figure 1**.

Low flow causing the flow switch to open during operation will create a soft lockout that will automatically reset after 15 minutes. This functionality will prevent short-cycling of the burner due to marginal water flow.



**Figure 50. Flow Switch**

### Low Water Cut-Off

The low water cut-off automatically shuts down the burner whenever water level drops below the level of the sensing probe. See **Figure 1**. A 5-second time delay prevents premature lockout due to temporary conditions such as power fluctuations or air pockets. The low water cut-off control is located in the control box.

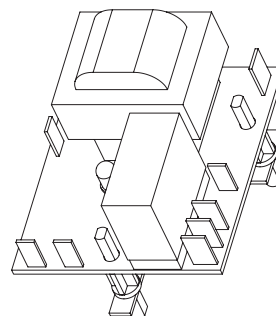

**Figure 51. Low Water Cut-Off**

**APPROVED**

### High and Low Gas Pressure Switches (Sales Order Option S-1/S-2)

The low gas pressure switch mounts upstream of the gas valve (on the inlet flange to the gas valve) and is accessible through the removable access panels on the top or front of the heater to reset the gas pressure switch, as necessary. See **Figure 1**. It is used to ensure that sufficient gas pressure is present for proper valve/regulator performance. The low gas pressure switch automatically shuts down the heater if gas supply drops below the factory setting of 3" WC for natural gas or propane gas.

The high gas pressure switch mounts downstream of the gas valve. See **Figure 1**. If the gas pressure regulator in the valve fails, the high gas pressure switch automatically shuts down the burner.

The low gas pressure switch must be set at 3" WC for either Nat or Propane Gas. The high gas pressure switch must be set at 3" WC for either Nat or Propane Gas. Scales on switches are approximate. Use manometer to set the switch settings.

Operation of either the High or Low Gas Pressure Switches will turn on an LED inside the switch housing. Push the top of the plastic switch housing as shown in **Figure 52** to reset a tripped pressure switch. The LED will go out when the switch is reset. No bleed line is required.

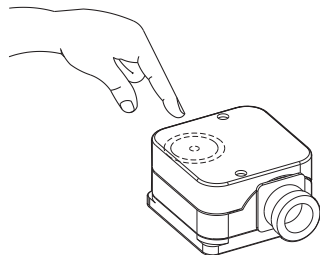

**Figure 52. High/Low Gas Pressure Switch**

### Blocked Vent Switch

This heater is equipped with a blocked vent pressure switch to prevent the operation of the heater when too much of the vent is blocked. This switch is located on the right side of the heater near the front. See **Figure 2**.

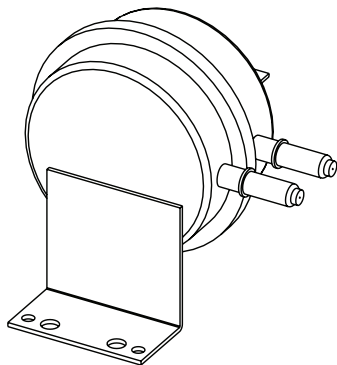

**Figure 53. Blocked Vent Switch**

### Condensate Switch

The condensate switch is located lower rear (right corner) of the heater. See **Figure 3**. Remove the lower access panel to access the condensate switch. The switch will shut the unit down in the event of excessive condensate in the condensate compartment of the heat exchanger.

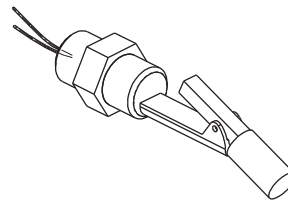

**Figure 54. Condensate Switch**

### Flow Meter (Sales Order Option F-15)

The heater can be equipped with a flow meter which measures flow through the heater and the control adjusts firing rate based on flow. See **Figure 1**.

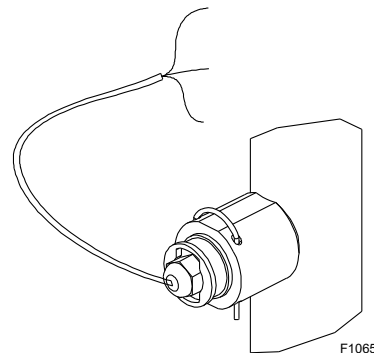
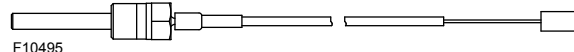

**Figure 55. Flow Meter**

### Vent Temp Sensor

The heater is equipped with a vent temperature sensor. Upon initial installation/commissioning of the heater, the vent material used for installation (PVC, CPVC, PP, or SS) must be entered into the control. See **Figure 4**. The factory default value is "PVC".

The control uses the input from this sensor to automatically reduce firing rate should the vent temperature approach the vent material temperature limits.



**Figure 56. Vent Temp Sensor**



**APPROVED**  
**View Menu**

**User Interface**

The touchscreen user interface uses a high-definition 4.3" (109 mm) capacitive screen. It includes an extensive graphical library used to represent different pipe configurations, error location, and operation of the unit. The touchscreen menu bar becomes visible at the bottom of the screen allowing navigation through additional icons (View, Adjust, Boiler, Tools, Document Viewer and Wi-Fi).

For detailed descriptions of the various screens, page flows and basic instructions, consult the Raypak Touchscreen Quick Start User Guide (241630), IBC Touchscreen Quick Start User Guide (241949) and VERSA IC<sup>®</sup> Manual (241493).

If your unit has Raymote installed, refer to the Raymote installation and operation manual (241788).

**Adjusting the Heater Setpoint**

Use the MENU button to open the menu options, select the ADJUST menu, go to System Settings page. Once in the system settings screen use the setpoint item. Adjust the setpoint using the UP and DOWN arrow.

After making the setpoint selection press SET button to apply the changes (a confirmation bar will turn green showing that value has been applied). See Table AA for details.

The VIEW menu is the default menu. See **Table Z**. It displays sensor temperatures, the modulation rate of the blower, heater cascade status, pump operation and CFH information. Some of the items displayed are mode specific and are only observable when its corresponding mode is active.

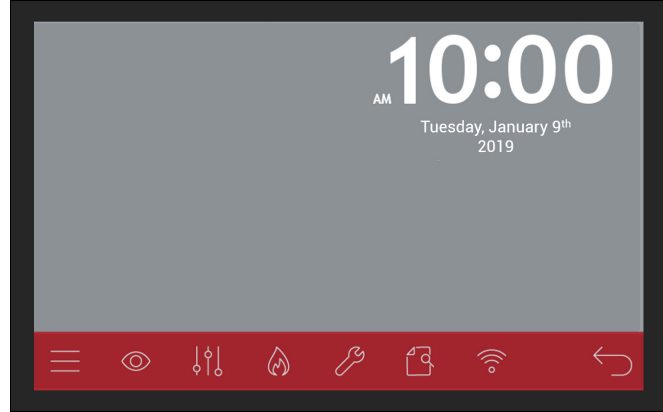

**Figure 57. User Interface (May Vary by Model)**

**Menu - Initial Adjustment**

To change settings on the touchscreen, press MENU icon, Adjust icon, System settings, System menu to open Adjust Settings menu. The ADJUST menu allows the installer to make adjustments to items shown in **Table AA**.

Refer to the VERSA IC<sup>®</sup> Manual (241493) for detailed setup instructions.

| Item          | Application       | Description   |
|---------------|-------------------|---|
| OUTDOOR       | MODE 1, 2, 3      | Outdoor air temperature, available when TARGET = RSET in ADJUST menu                                    |
| Target        | MODE 1, 2, 3      | Current target temperature, available when Target = SETP in the ADJUST menu (default), and (EMS / MODB) |
| SUPPLY        | MODE 1, 2, 3      | Current system supply temperature   |
| IND SUPPLY    | MODE 3            | Current temperature being supplied to the indirect system   |
| Boil OUTLET   | All               | Current heater outlet temperature   |
| Boil INLET    | All               | Current heater inlet temperature  |
| Boil ΔT       | All               | Current temperature difference between heater outlet and heater inlet                                   |
| FOLLOWERS     | CASCADE MASTER    | Number of followers on Cascade  |
| DHW SUPPLY    | MODE 2, 3         | Current indirect DHW supply temperature   |
| TANK          | Water Heater only | Current Tank Temperature  |
| Heater STATUS | All               | IDLE, PREPURGE, IGNITION MOD RATE %, POSTPURGE, SOFTLOCK, HARDLOCK                                      |

**Table Z. System View**



| Item                    | Application                         | Range  | Description  | Default      |
|-------------------------|-------------------------------------|--|--|--------------|
| TARGET                  | MODE 1, 2, 3                        | RSET <> SETP                                     | RSET = Outdoor Reset, SETP =Setpoint   | SETP         |
| MODE                    | MODE 1, 2, 3                        | 1, 2, 3  | Piping and application configuration   | 1            |
| SETPOINT                | MODE 1, 2, 3                        | 50°F to 192°F (10°C to 89°C)                     | Heater target temperature while a heat demand is present for setpoint operation  | 180°F (82°C) |
| TANK SETPOINT           | WATER HEATER                        | 50°F to 160°F (10°C to 71°C)                     | Water heater target temperature while a heat demand is present for setpoint operation  | 150°F (65°C) |
| OUT START               | MODE 1, 2, 3                        | 35°F to 85°F (2°C to 29°C)                       | Outdoor starting temperature - outdoor reset   | 70°F (21°C)  |
| OUT DESIGN              | MODE 1, 2, 3                        | -60°F to 45°F (-51°C to 7°C)                     | Outdoor design temperature - outdoor reset   | 10°F (-12°C) |
| Boil START              | MODE 1, 2, 3                        | 35°F to 150°F (2°C to 66°C)                      | Starting heater target temp when the outdoor temperature is at outdoor start outdoor reset   | 70°F (21°C)  |
| Boil DESIGN             | MODE 1, 2, 3                        | 70°F to 200°F (21°C to 93°C)                     | Design heater target temperature when the outdoor temperature is at outdoor design outdoor reset   | 180°F (82°C) |
| TARGET MAX              | MODE 1, 2, 3                        | 100°F (38°C) to PIM value*                       | Maximum target system temperature  | 200°F (93°C) |
| TARGET MIN              | MODE 1, 2, 3                        | OFF, 50°F to 190°F (10°C to 88°C)                | Minimum target system temperature  | 50°F (10°C)  |
| TARGET DIFF             | MODE 1, 2, 3                        | 2°F to 42°F (1°C to 23.3°C)                      | Differential for target system temperature   | 10°F (5.6°C) |
| IND SENSOR              | MODE 1, 2, 3                        | OFF <> ON  | Selects whether a DHW sensor is used for indirect DHW tank   | OFF          |
| IND SETP                | MODE 2, 3                           | OFF, 50°F (10°C) to 180°F (82°C)                 | Target Indirect DHW Temperature, requires IND SENSOR = ON  | 140°F (60°C) |
| DHW DIFF                | MODE 2, 3                           | 2°F to 10°F (1°C to 5.6°C)                       | Target indirect DHW tank temp, requires IND SENSOR = ON  | 6°F (3.4°C)  |
| GLYCOL                  | IDLE only                           | 0% - 50%   | Glycol concentration   | 50%          |
| Delta T Offset          | MODE 1, 2, 3                        | 2°F to 15°F (1°C to 8.5°C)                       | DT Offset (Flow Warning threshold)   | 10°F         |
| Isol Valve ON/OFF       | IDLE only                           | 0:CLOSE, 1:OPEN                                  | Manual Open / Close of ISOL Valve  | 1, OPEN      |
| VENT MATERIAL           | IDLE only                           | PVC, CPVC, PPS, SS                               | Defines VENT Piping material. To update value unit must be in IDLE status. (Tap 6 times on setting label to enable SET button)                       | PVC          |
| VENT DIFF               | IDLE only                           | 1°F to 20°F (1°C to 11.2°C)                      | Subtractive differential of VENT Temperature. This value sets the threshold for VENT protection to be active   | 10°F (5.6°C) |
| VENT RATE               | IDLE only                           | MAX Firing Rate to 80%                           | Forced firing rate when VENT protection is present   | 50%          |
| Cascade                 | Cascade Only                        | OFF<>5<>6<>7<>8                                  | Cascade ID only applicable to Tn_bus follower units  | OFF          |
| Cascade Type            | Cascade Master only                 | SEQ<>PAR   | Cascade operation type   | SEQ          |
| Cascade Alarm           | Cascade Master only                 | ON<>OFF  | Cascade Alarm to all units in case of any unit presents alarm using Primary Only piping  | ON           |
| Cascade MIN Flow Offset | Primary - only Piping Configuration | -25 to 15 GPM                                    | Overrides MIN flow condition for next unit in cascade to allow next unit to be called to fire sooner or later.                                       | 0            |
| Cascade Speed           | Cascade Master only                 | -10 to 10  | Cascade speed response multiplier.   | 1            |
| Flow Override           | IDLE Only                           | 0,MIN % to 80%                                   | Overrides MIN Flow condition for ignition sequence, setting expires in 24hrs.  | 0            |
| IND SUPPLY              | MODE 2, 3                           | OFF, 50°F (10°C) to PIM value*                   | Target heater temperature for the DHW heat exchanger during indirect DHW operation, requires IND SENSOR = OFF  | 180°F (82°C) |
| DHW PRIORITY            | MODE 2                              | OFF <> ON  | Selects whether or not Indirect DHW priority is active during indirect DHW operation   | OFF          |
| PRI OVR                 | MODE 2, 3                           | Au, 0:10hr to 2:00hr                             | Sets the length of the indirect DHW priority override time   | 1:00hr       |
| SYS PURGE               | All                                 | OFF, 0:20min to 20:00min                         | Sets the length of the system pump post purge  | 20 seconds   |
| MIX TYPE                | MIX                                 | Boiler (VALVE, PUMP, PLNT) Water Heater (1 <> 2) | Selects the type of control depending on pipe configuration for CWP  | H VALVE      |
| MIX TARGET              | MIX                                 | 50°F to 140°F (10°C to 60°C)                     | Inlet Target Temperature   | 120°F (49°C) |
| MIX LOCK                | MIX                                 | OFF <> ON  | The equipment will trigger a warning when "MIX Target" is not reached within 7 minutes. MIX LOCK = ON; Alarm and lockout, MIX LOCK = OFF; Alarm only | OFF          |
| MIX TRIM                | MIX                                 | -5 to 5  | This adjustment is for various types and sizes of units as well as various actuator motor speeds and types supplied by manufacturer                  | 0            |
| MIX SPEED               | MIX                                 | SLOW <> MED <> FAST                              | This setting defines speed of response   | MED          |
| MIX INV                 | MIX                                 | OFF <> ON  | Relates to the use of spring return actuators with a proportional valve  | OFF          |
| WWSD                    | MODE 1, 2, 3                        | 40°F to 100°F (4°C to 38°C)                      | The system warm weather shutdown temperature outdoor reset, requires TARGET = RSET   | 70°F (21°C)  |
| UNITS                   | All                                 | deg F <> deg C                                   | Show units using icons in display  | deg F        |
| MODBUS                  | All                                 | OFF <> MNTR <>TEMP <> RATE                       | ModBus Operating Mode: Off, Monitor, Temp Control, Rate Control  | MNTR         |
| ADDRESS                 | All                                 | 1 to 247   | ModBus slave address   | 1            |
| DATA TYPE               | All                                 | RTU <> ASCII                                     | Modbus data type   | RTU          |
| BAUD RATE               | All                                 | 2400 <> 9600 <> 19K2 <>57K6 <> 115K              |  | 19K2         |
| PARITY                  | All                                 | NONE <> EVEN <> ODD                              |  | EVEN         |

\* Maximum operator dial setting.

**Table AA. Setup/Adjust Menus  
UNCONTROLLED DOCUMENT IF PRINTED**

**APPROVED**

**Boiler Menu**

The Boiler Menu displays various items regarding ignition, temperature monitoring, and modulation rates. As well as software and hardware information. Up to 15 error codes can be reviewed in the Boiler Menu.

| Item           | Application             | Description   |
|----------------|-------------------------|---|
| Heater 1       | ALL                     | Enables Boiler for operation  |
| Heater 2       | CASCADE                 | Enables Ft-bus Boiler 2 for cascade operation   |
| Heater 3       | CASCADE                 | Enables Ft-bus Boiler 3 for cascade operation   |
| Heater 4       | CASCADE                 | Enables Ft-bu Boiler 4 for cascade operation  |
| CASCADE        | TN-bus Cascade Follower | Set Cascade ID for TN-bus follower, see VERSA IC® Manual (241493) for details.  |
| IGNITION       | ALL                     | <p>IDLE=no CFH;<br/>                     PREP=pre-purge or inter-purge between trials for ignition;<br/>                     IGN=trial for ignition;<br/>                     BURN=burner operating;<br/>                     POST=post purge;<br/>                     HARD=a hard lockout fault has occurred requiring manual-reset (Ignition Lockout or manual high-limit); and<br/>                     SOFT=a soft lockout fault has occurred which interrupts the heating cycle (any safety other than ignition or manual high-limit)</p> <p>The CFH will resume after the soft lockout fault has been corrected and a 15 min. waiting period has expired</p> |
| VENT WALL      | ALL                     | Monitors vent temperature and adjust firing rate if vent temperature approaches limit for vent material installed/selected  |
| LIMIT TEMP     | ALL                     | Current Outlet-Limit temperature  |
| EMS Vdc        | ALL                     | Current EMS signal in Volts DC  |
| FIRE RATE      | ALL                     | PIM firing rate   |
| SPEEDX 1000    | ALL                     | Blower speed in revolutions per minute (rpm) x 1000   |
| OUTLET MAX     | Mode 1, 2, 3            | Defines Max Outlet temperature offset above Target Setpoint (Press and hold up and down arrows for 3 seconds to enable adjustment). see VERSA IC® Manual (241493)   |
| OPERATOR       | ALL                     | Operator Potentiometer setting on PIM   |
| DIFF           | ALL                     | Current auto differential – Fixed by PIM  |
| Pump Post      | ALL                     | Sets the length of the heater pump purge  |
| FLAME CUR      | ALL                     | Flame current in micro-amps (µA)  |
| MASS           | ALL                     | Thermal mass recovery see VERSA IC® Manual (241493)   |
| IDENTITY       | ALL                     | Identifies the unit as heater, water heater or pool heater  |
| IGN TYPE       | ALL                     | PIM Board type  |
| ID CARD        | ALL                     | Identifies the Unit's Identity Card   |
| SW ID          | ALL                     | PIM Software identification number  |
| ERROR CODE     | ALL                     | Current Error Message   |
| MIN MOD ADJUST | ALL                     | Overrides PIM Low Fire Mod value up to 60%  |

**Table AB. Boiler Menu**

**APPROVED**

**Monitor Menu**

The Monitor Menu records and displays critical Heater information, such as, Cycle times, Run times, and Maximum/Minimum temperature readings depending on the setup.

| Item                 | Application  | Description  |
|----------------------|--------------|--|
| RUN TIME Burner 1    | All          | Burner run time (hours). Press UP/DOWN for 1 sec to clear  |
| Cycles Burner        | All          | Number of burner cycles. Press UP/DOWN for 1 sec to clear  |
| RUN TIME Heater pump | All          | Heater pump run time (hours). Press UP/DOWN for 1 sec to clear   |
| RUN TIME System pump | All          | System pump run time (hours). Press UP/DOWN for 1 sec to clear   |
| RUN TIME DHW pump    | MODE 2, 3    | DHW pump run time (hours). Press UP/DOWN for 1 sec to clear  |
| OUTLET HI            | All          | Records the highest heater outlet temperature. Press UP/DOWN for 1 sec to clear                          |
| OUTLET LO            | All          | Records the lowest heater outlet temperature. Press UP/DOWN for 1 sec to clear                           |
| INLET HI             | All          | Records the highest heater inlet temperature. Press UP/DOWN for 1 sec to clear                           |
| INLET LO             | All          | Records the lowest heater inlet temperature. Press UP/DOWN for 1 sec to clear                            |
| DELTA T              | All          | Captures the highest Delta T Temperature recorded. Press UP & DOWN buttons for 3 sec to clear this entry |
| OUTDOOR HI           | MODE 1, 2, 3 | Records the highest outdoor temperature. Press UP/DOWN for 1 sec to clear                                |
| OUTDOOR LO           | MODE 1, 2, 3 | Records the lowest outdoor temperature. Press UP/DOWN for 1 sec to clear                                 |
| SYSTEM HI            | All          | Records the highest supply temperature. Press UP/DOWN for 1 sec to clear                                 |
| SYSTEM LO            | All          | Records the lowest supply temperature. Press UP/DOWN for 1 sec to clear                                  |
| IND HI               | MODE 1, 2, 3 | Records the highest Indirect supply temperature. Press UP/DOWN for 1 sec to clear                        |
| IND LO               | MODE 1, 2, 3 | Records the lowest Indirect supply temperature. Press UP/DOWN for 1 sec to clear                         |
| TANK HI              | Water Heater | Records the highest TANK temperature. Press UP/DOWN for 1 sec to clear                                   |
| TANK LO              | Water Heater | Records the lowest TANK temperature. Press UP/DOWN for 1 sec to clear                                    |
| PIM DIP SWITCHES     |              | PIM DIP SW configuration   |
| VERSA DIP SWITCHES   |              | VERSA DIP SW Configuration   |
| PIM SW Revision      |              | Software revision number   |

**Table AC. Monitor Menu**

**Toolbox Menu**

The Toolbox Menu logs all error codes from the VERSA and PIM, as well as other functions. Up to 15 error codes can be logged.

| Item                                  | Description  |
|---------------------------------------|--|
| Lookup Active Error                   | Look up and display the active error info  |
| USER TEST                             | Select ON to start the function. The setting returns to default after the test is run  |
| MAX HEAT                              | Select ON to start the function. The setting will time out to OFF after 24 hours or can be set to OFF again by the user. See VERSA IC® Manual (241493) for details |
| P/N XXXXXX                            | Software number of the manufacturer VERSA  |
| DEFAULTS                              | Resets to factory settings. Press UP and DOWN for 1 second to show CLR and load factory defaults to all settings. This will also clear all history                 |
| HISTORY<br><i>lookup logged error</i> | Displayed when an error code is present. 1 indicates the most recent error code. Press UP and DOWN for 1 second to clear the error logs                            |

**Table AD. Toolbox Menu**

**APPROVED**

| INPUT SIGNAL VDC | BOILER °F/°C | WATER HEATER °F/°C | INPUT SIGNAL mA | EXAMPLE               |                       |
|------------------|--------------|--------------------|-----------------|-----------------------|-----------------------|
|                  |              |                    |                 | Target Min 140°F/60°C | Target Max 180°F/82°C |
| 10.0             | 192°F/ 89°C  | 160°F/ 71°C        | 20.0            | 180°F/ 82°C           |                       |
| 9.9              | 190°F/ 88°C  | 159°F/ 71°C        | 19.8            | 180°F/ 82°C           |                       |
| 9.8              | 189°F/ 87°C  | 158°F/ 70°C        | 19.7            | 180°F/ 82°C           |                       |
| 9.7              | 187°F/ 86°C  | 156°F/ 69°C        | 19.5            | 179°F/ 81°C           |                       |
| 9.6              | 186°F/ 85°C  | 155°F/ 68°C        | 19.4            | 179°F/ 81°C           |                       |
| 9.5              | 184°F/ 85°C  | 154°F/ 68°C        | 19.2            | 178°F/ 81°C           |                       |
| 9.4              | 183°F/ 84°C  | 153°F/ 67°C        | 19.0            | 178°F/ 81°C           |                       |
| 9.3              | 181°F/ 83°C  | 151°F/ 66°C        | 18.9            | 177°F/ 80°C           |                       |
| 9.2              | 179°F/ 82°C  | 150°F/ 66°C        | 18.7            | 177°F/ 80°C           |                       |
| 9.1              | 178°F/ 81°C  | 149°F/ 65°C        | 18.6            | 176°F/ 80°C           |                       |
| 9.0              | 176°F/ 80°C  | 148°F/ 64°C        | 18.4            | 176°F/ 80°C           |                       |
| 8.9              | 175°F/ 79°C  | 147°F/ 64°C        | 18.2            | 176°F/ 79°C           |                       |
| 8.8              | 173°F/ 78°C  | 145°F/ 63°C        | 18.1            | 175°F/ 79°C           |                       |
| 8.7              | 171°F/ 77°C  | 144°F/ 62°C        | 17.9            | 175°F/ 79°C           |                       |
| 8.6              | 170°F/ 77°C  | 143°F/ 62°C        | 17.8            | 174°F/ 79°C           |                       |
| 8.5              | 168°F/ 76°C  | 142°F/ 61°C        | 17.6            | 174°F/ 78°C           |                       |
| 8.4              | 167°F/ 75°C  | 140°F/ 60°C        | 17.4            | 173°F/ 78°C           |                       |
| 8.3              | 165°F/ 74°C  | 139°F/ 59°C        | 17.3            | 173°F/ 78°C           |                       |
| 8.2              | 164°F/ 73°C  | 138°F/ 59°C        | 17.1            | 172°F/ 78°C           |                       |
| 8.1              | 162°F/ 72°C  | 137°F/ 58°C        | 17.0            | 172°F/ 78°C           |                       |
| 8.0              | 160°F/ 71°C  | 136°F/ 58°C        | 16.8            | 172°F/ 77°C           |                       |
| 7.9              | 159°F/ 70°C  | 134°F/ 57°C        | 16.6            | 171°F/ 77°C           |                       |
| 7.8              | 157°F/ 70°C  | 133°F/ 56°C        | 16.5            | 171°F/ 77°C           |                       |
| 7.7              | 156°F/ 69°C  | 132°F/ 56°C        | 16.3            | 170°F/ 77°C           |                       |
| 7.6              | 154°F/ 68°C  | 131°F/ 55°C        | 16.2            | 170°F/ 76°C           |                       |
| 7.5              | 153°F/ 67°C  | 129°F/ 54°C        | 16.0            | 169°F/ 76°C           |                       |
| 7.4              | 151°F/ 66°C  | 128°F/ 53°C        | 15.8            | 169°F/ 76°C           |                       |
| 7.3              | 149°F/ 65°C  | 127°F/ 53°C        | 15.7            | 168°F/ 76°C           |                       |
| 7.2              | 148°F/ 64°C  | 126°F/ 52°C        | 15.5            | 168°F/ 75°C           |                       |
| 7.1              | 146°F/ 63°C  | 125°F/ 52°C        | 15.4            | 168°F/ 75°C           |                       |
| 7.0              | 145°F/ 63°C  | 123°F/ 51°C        | 15.2            | 167°F/ 75°C           |                       |
| 6.9              | 143°F/ 62°C  | 122°F/ 50°C        | 15.0            | 167°F/ 75°C           |                       |
| 6.8              | 142°F/ 61°C  | 121°F/ 49°C        | 14.9            | 166°F/ 74°C           |                       |
| 6.7              | 140°F/ 60°C  | 120°F/ 49°C        | 14.7            | 166°F/ 74°C           |                       |
| 6.6              | 138°F/ 59°C  | 118°F/ 48°C        | 14.6            | 165°F/ 74°C           |                       |
| 6.5              | 137°F/ 58°C  | 117°F/ 47°C        | 14.4            | 165°F/ 74°C           |                       |
| 6.4              | 135°F/ 57°C  | 116°F/ 47°C        | 14.2            | 164°F/ 73°C           |                       |
| 6.3              | 134°F/ 56°C  | 115°F/ 46°C        | 14.1            | 164°F/ 73°C           |                       |
| 6.2              | 132°F/ 56°C  | 114°F/ 46°C        | 13.9            | 164°F/ 73°C           |                       |
| 6.1              | 130°F/ 55°C  | 112°F/ 44°C        | 13.8            | 163°F/ 73°C           |                       |
| 6.0              | 129°F/ 54°C  | 111°F/ 44°C        | 13.6            | 163°F/ 72°C           |                       |
| 5.9              | 127°F/ 53°C  | 110°F/ 43°C        | 13.4            | 162°F/ 72°C           |                       |
| 5.8              | 126°F/ 52°C  | 109°F/ 43°C        | 13.3            | 162°F/ 72°C           |                       |
| 5.7              | 124°F/ 51°C  | 107°F/ 42°C        | 13.1            | 161°F/ 72°C           |                       |
| 5.6              | 123°F/ 50°C  | 106°F/ 41°C        | 13.0            | 161°F/ 71°C           |                       |
| 5.5              | 121°F/ 49°C  | 105°F/ 41°C        | 12.8            | 160°F/ 71°C           |                       |
| 5.4              | 119°F/ 49°C  | 104°F/ 40°C        | 12.6            | 160°F/ 71°C           |                       |
| 5.3              | 118°F/ 48°C  | 103°F/ 39°C        | 12.5            | 160°F/ 71°C           |                       |
| 5.2              | 116°F/ 47°C  | 101°F/ 38°C        | 12.3            | 159°F/ 70°C           |                       |
| 5.1              | 115°F/ 46°C  | 100°F/ 38°C        | 12.2            | 159°F/ 70°C           |                       |

\* Setpoints above 104°F/40°C are only available if the setpoint range has been extended in the field.

Table AE continued on next page

**UNCONTROLLED DOCUMENT IF PRINTED**

**APPROVED**

| INPUT SIGNAL VDC | BOILER °F/°C        | WATER HEATER °F/°C | INPUT SIGNAL mA | EXAMPLE               |                       |
|------------------|---------------------|--------------------|-----------------|-----------------------|-----------------------|
|                  |                     |                    |                 | Target Min 140°F/60°C | Target Max 180°F/82°C |
| 5.0              | 113°F/ 45°C         | 99°F/ 37°C         | 12.0            | 158°F/ 70°C           |                       |
| 4.9              | 112°F/ 44°C         | 98°F/ 37°C         | 11.8            | 158°F/ 70°C           |                       |
| 4.8              | 110°F/ 43°C         | 96°F/ 36°C         | 11.7            | 157°F/ 69°C           |                       |
| 4.7              | 108°F/ 42°C         | 95°F/ 35°C         | 11.5            | 157°F/ 69°C           |                       |
| 4.6              | 107°F/ 42°C         | 94°F/ 34°C         | 11.4            | 156°F/ 69°C           |                       |
| 4.5              | 105°F/ 41°C         | 93°F/ 34°C         | 11.2            | 156°F/ 69°C           |                       |
| 4.4              | 104°F/ 40°C         | 92°F/ 33°C         | 11.0            | 156°F/ 68°C           |                       |
| 4.3              | 102°F/ 39°C         | 90°F/ 32°C         | 10.9            | 155°F/ 68°C           |                       |
| 4.2              | 101°F/ 38°C         | 89°F/ 32°C         | 10.7            | 155°F/ 68°C           |                       |
| 4.1              | 99°F/ 37°C          | 88°F/ 31°C         | 10.6            | 154°F/ 68°C           |                       |
| 4.0              | 97°F/ 36°C          | 87°F/ 31°C         | 10.4            | 154°F/ 67°C           |                       |
| 3.9              | 96°F/ 35°C          | 85°F/ 29°C         | 10.2            | 153°F/ 67°C           |                       |
| 3.8              | 94°F/ 35°C          | 84°F/ 29°C         | 10.1            | 153°F/ 67°C           |                       |
| 3.7              | 93°F/ 34°C          | 83°F/ 28°C         | 9.9             | 152°F/ 67°C           |                       |
| 3.6              | 91°F/ 33°C          | 82°F/ 28°C         | 9.8             | 152°F/ 66°C           |                       |
| 3.5              | 89°F/ 32°C          | 81°F/ 27°C         | 9.6             | 152°F/ 66°C           |                       |
| 3.4              | 88°F/ 31°C          | 79°F/ 26°C         | 9.4             | 151°F/ 66°C           |                       |
| 3.3              | 86°F/ 30°C          | 78°F/ 26°C         | 9.3             | 151°F/ 66°C           |                       |
| 3.2              | 85°F/ 29°C          | 77°F/ 25°C         | 9.1             | 150°F/ 65°C           |                       |
| 3.1              | 83°F/ 28°C          | 76°F/ 24°C         | 9.0             | 150°F/ 65°C           |                       |
| 3.0              | 82°F/ 28°C          | 74°F/ 23°C         | 8.8             | 149°F/ 65°C           |                       |
| 2.9              | 80°F/ 27°C          | 73°F/ 23°C         | 8.6             | 149°F/ 65°C           |                       |
| 2.8              | 78°F/ 26°C          | 72°F/ 22°C         | 8.5             | 148°F/ 64°C           |                       |
| 2.7              | 77°F/ 25°C          | 71°F/ 22°C         | 8.3             | 148°F/ 64°C           |                       |
| 2.6              | 75°F/ 24°C          | 70°F/ 21°C         | 8.2             | 148°F/ 64°C           |                       |
| 2.5              | 74°F/ 23°C          | 68°F/ 20°C         | 8.0             | 147°F/ 64°C           |                       |
| 2.4              | 72°F/ 22°C          | 67°F/ 19°C         | 7.8             | 147°F/ 63°C           |                       |
| 2.3              | 71°F/ 21°C          | 66°F/ 19°C         | 7.7             | 146°F/ 63°C           |                       |
| 2.2              | 69°F/ 21°C          | 65°F/ 18°C         | 7.5             | 146°F/ 63°C           |                       |
| 2.1              | 67°F/ 20°C          | 63°F/ 17°C         | 7.4             | 145°F/ 63°C           |                       |
| 2.0              | 66°F/ 19°C          | 62°F/ 17°C         | 7.2             | 145°F/ 62°C           |                       |
| 1.9              | 64°F/ 18°C          | 61°F/ 16°C         | 7.0             | 144°F/ 62°C           |                       |
| 1.8              | 63°F/ 17°C          | 60°F/ 16°C         | 6.9             | 144°F/ 62°C           |                       |
| 1.7              | 61°F/ 16°C          | 59°F/ 15°C         | 6.7             | 144°F/ 62°C           |                       |
| 1.6              | 60°F/ 15°C          | 57°F/ 14°C         | 6.6             | 143°F/ 61°C           |                       |
| 1.5              | 58°F/ 14°C          | 56°F/ 13°C         | 6.4             | 143°F/ 61°C           |                       |
| 1.4              | 56°F/ 14°C          | 55°F/ 13°C         | 6.2             | 142°F/ 61°C           |                       |
| 1.3              | 55°F/ 13°C          | 54°F/ 12°C         | 6.1             | 142°F/ 61°C           |                       |
| 1.2              | 53°F/ 12°C          | 52°F/ 11°C         | 5.9             | 141°F/ 60°C           |                       |
| 1.1              | 52°F/ 11°C          | 51°F/ 11°C         | 5.8             | 141°F/ 60°C           |                       |
| 1.0              | 50°F/ 10°C          | 50°F/ 10°C         | 5.6             | 140°F/ 60°C           |                       |
| 0.9              | Heater Idle         |                    | 81°F/ 27°C      |                       |                       |
| 0.8              |                     |                    | 80°F/ 26.6°C    |                       |                       |
| 0.7              | System Pump Enable  |                    | 80°F/ 26.3°C    |                       |                       |
| 0.6              |                     | 79°F/ 25.9°C       | 5.0             |                       |                       |
| 0.5              | System Pump Disable |                    | 78°F/ 25.6°C    |                       |                       |
| 0.4              | System Offline      |                    | 78°F/ 25.3°C    |                       |                       |
| 0.3              |                     |                    | 77°F/ 24.9°C    |                       |                       |
| 0.2              |                     |                    | 77°F/ 24.6°C    |                       |                       |
| 0.1              |                     |                    | 76°F/ 24.2°C    |                       |                       |
| 0.0              |                     |                    | 75°F/ 23.9°C    |                       |                       |

**Table AE. VERSA Setpoint 0-10 VDC / 4 - 20 mA Operation  
UNCONTROLLED DOCUMENT IF PRINTED**

## APPROVED

### Outdoor Reset Concept

The Temperature controller can change the System Set Point based on outdoor temperature (Outdoor Reset). The temperature controller varies the temperature of the circulating heating water in response to changes in the outdoor temperature. The heating water temperature is controlled through the modulation and/or sequencing of the cascade. The Temperature controller can also control the system circulating pump with an adjustable Outdoor Cutoff.

When the outdoor temperature is above the Outdoor Cutoff, the pump is turned off and no heating water is circulated through the system. When the outdoor temperature drops below the Outdoor Cutoff, the system pump relay is activated and the heating water circulates through the system. The temperature of the heating water is controlled by the Reset Ratio, Water Offset, and changes with the outdoor temperature.

### Reset Ratio/Outdoor Reset

When a building is being heated, heat escapes through the walls, doors, and windows to the colder outside air. The colder the outside temperature, the more heat escapes. If you can input heat into the building at the same rate that it is lost out of the building, then the building temperatures will remain constant. The Reset Ratio is an adjustment that lets you achieve this equilibrium between heat input and heat loss. The starting point for most systems is the 1.00 (OD):1.00 (SYS) (Outdoor Temperature: Heating Water Temperature) ratio. This means that for every degree the outdoor temperature drops, the temperature of the heating water will increase one degree.

With the VERSA, both ends of the slope are adjustable. It is factory set at 70°F (21°C) water temperature (Boil START) at 70°F (21°C) outdoor air (OUT START), and 180°F (82°C) water temperature (Boil DESIGN) at 10°F (-12°C) outdoor air (OUT DESIGN).

Each building has different heat loss characteristics. A very well insulated building will not lose much heat to the outside air, and may need a Reset Ratio of 2.00 (OD):1.00 (SYS) (Outdoor: Water). This means the outdoor temperature would have to drop 2 degrees to increase the water temperature 1 degree. On the other hand, a poorly insulated building may need a Reset Ratio of 1.00 (OD):2.00 (SYS). This means that for each degree the outdoor temperature dropped the water temperature will increase 2 degrees.

The VERSA Reset Ratio allows for full customization to match any buildings heat loss characteristics. A heating curve that relies not only on Outdoor temperature but also on the type of radiation will improve heat comfort. The user can fine tune these adjustments based on the specific building need.

### Reset Ratio Settings

The controller uses the four following settings to determine the reset ratio:

1. Heater Start (**Boil START**). The Boil START temperature is the theoretical heater supply water temperature that the heating system requires when the outdoor air temperature equals the OUT START temperature setting. The Boil START is typically set to the desired building temperature.
2. Outdoor Start (**OUT START**). The OUT START temperature is the outdoor temperature at which the control provides the Boil START water temperature to the system. The OUT START is typically set to the desired building temperature.
3. Outdoor Design (**OUT DESIGN**). The OUT START is the outdoor temperature that is typical coldest annual temperature where the building is located. This temperature is used when completing heat loss calculation for the building.
4. Heater Design (**Boil DESIGN**). The Boil DESIGN temperature is the water temperature required to heat the heater zones when the outdoor air is as cold as the OUT DESIGN temperature.

### Warm Weather Shut Down (WWSD)

When the outdoor air temperature rises above the WWSD setting, the control turns on the WWSD segment in the display. When the control is in the Warm Weather Shut Down, the Dem 1 segment is displayed if there is a heat demand. However, the control does not operate the heater to satisfy this demand. The control continues to respond to DHW demands.

### Reset Ratio

The controller uses the following four settings to calculate the Reset Ratio (RR). For example, when using the default values, the RR is:

$$\text{RESET RATIO} = \frac{(\text{OUTDOOR START} - \text{OUTDOOR DESIGN})}{(\text{BOILER DESIGN} - \text{BOILER START})}$$

$$\text{RR} = (70 - 10) / (180 - 70) = 0.55$$

Therefore, the RR is 0.55:1 (Outdoor : Water).

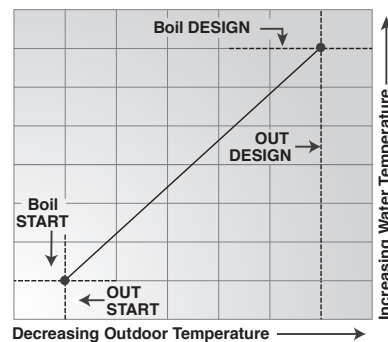

Figure 58. Reset Ratio

**NOTE:** The wiring diagrams in this manual show all standard options. Refer to the large wiring diagram provided with your heater for options installed on your specific unit(s).





## 7. START-UP

**NOTE:** The following steps must be performed by a factory-trained technician.

### Pre Start-up

#### Filling System (Heating Heaters)

Fill system with water. Purge all air from the system. Lower system pressure. Open valves for normal system operation, and fill system through feed pressure. Manually open air vent on the compression tank until water appears, then close vent.

#### Air Purge

Purge all air from system before heater operation. This can normally be accomplished by opening a down-stream valve.

**CAUTION:** An air vent valve should be field-installed at the highest point in the system for proper operation.

#### Venting System Inspection

1. Check all vent pipe connections and flue pipe material.
2. Make sure vent terminations are installed per code and are clear of all debris or blockage.
3. Ensure vent material has been inputted into the VERSA IC®.

#### Lighting Instructions/Warnings

##### For Your Safety

This appliance has a direct surface igniter. It is equipped with an ignition device which automatically lights the burners. Do not try to light the burners by hand.

**WARNING:** If you do not follow these instructions exactly, a fire or explosion may result causing property damage, personal injury or loss of life.

BEFORE OPERATING, smell all around the appliance area for gas. Be sure to smell near the floor because some gas is heavier than air and will settle on the floor.

##### WHAT TO DO IF YOU SMELL GAS:

- Do not try to light any appliance.
- Do not touch any electrical switch; do not use any telephone in your building.
- Immediately call your gas supplier from a neighbor's telephone. Follow the gas supplier's instructions.
- If you cannot reach your gas supplier, call the fire department.

##### APPROVED

- Use only your hand to turn the gas control valve handle. Never use tools. If the handle will not turn by hand, do not try to repair it; call a qualified service technician. Forced or attempted repair may result in a fire or explosion.
- Do not use this appliance if any part has been under water, immediately call a qualified service technician to inspect the appliance and to replace any part of the control system and any gas control which has been under water.
- Check around unit for debris and remove combustible products, i.e. gasoline, etc.

### Pre Start-up Check

1. Verify the heater is filled with water.
2. Check system piping for leaks. If found, repair immediately.
3. Vent air from system. Air in system can interfere with water circulation.
4. Purge air from gas line to heater.

### Initial Start-up

#### Required tools

- (1) 12-0-12 (24" scale) U-tube manometer
- (2) 6-0-6 (12" scale) U-tube manometer
- Screwdrivers (assorted sizes and shapes)
- (1) Crescent wrench (8" or 10")
- (1) Multi-meter
- (1) Flue gas analyzer

(Metric Allen wrenches will be required for servicing the gas valve, but not during start-up)

**NOTE:** Technician performing initial start-up must carry a calibrated combustion analyzer to ensure desired combustion levels are achieved.

### Preparation

#### Check Power Supply

With multimeter at incoming power, check voltage as applicable:

**WARNING:** Do not turn on gas at this time.

APPROVED

## Attach Manometers to Measure Pressures

**NOTE: Digital manometers are not recommended.**

1. Turn off main gas valve.
2. Attach (1) 12" scale manometer to an upstream bleedle valve on the gas supply pipe to the heater (Measure point "A" in **Figure 59**).
3. Attach (1) 24" scale manometer to the manifold pressure tap on the gas valve (Measure point "B" in **Figure 59**).
4. Attach (1) 12" scale manometer on the fan suction pressure hose. Pull black cap from the air pressure tee as shown in **Figure 59** and connect the manometer (Measure point "C" in **Figure 59**).

**NOTE: Retain caps for reinstallation later.**

## Check Gas Supply Pressure

1. Slowly turn on main gas shut-off valve.

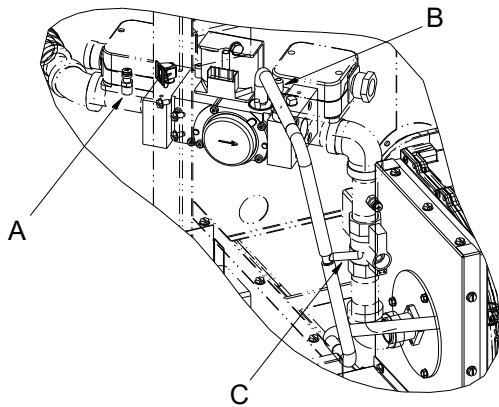

MODELS 300 - 500

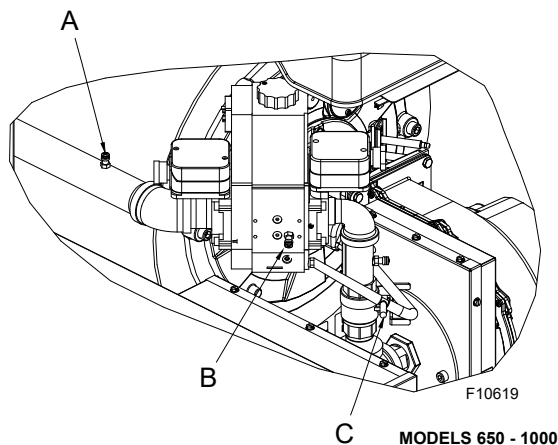

F10619

MODELS 650 - 1000

- A: Gas Supply Pressure**  
**B: Gas Manifold Pressure**  
**C: Air Pressure Tee**

Figure 59. Gas Pressure Measurement Locations

2. Read the gas supply pressure from the manometer; minimum supply pressure for natural gas is 4" WC, recommended supply is 7" WC, minimum supply pressure for propane gas is 8" WC, recommended supply is 11" WC (dynamic readings, full fire input).
3. If the gas pressure is greater than 14" WC, turn off the main gas shut-off valve, upstream of the heater.

## Start-Up

**NOTE: The values in Table AE and Table AF represent the conditions when the heater is at full firing rate at sea level.**

**NOTE: Pressure and combustion data are provided with the heater.**

1. Turn power on.
2. Turn on the heater, switch Enable/Disable rocker switch to top position to enable CFH wait approximately 15 seconds after the blower starts, the igniter should start to glow (observable through the observation port located on top of the combustion chamber). Gas valve should open in 45-60 seconds.
3. The heater ignites at 30% to 40% of full rate (as indicated on the touch screen display of the temperature controller located behind the front panel).
4. If the burner fails to light on the first 4-second trial for ignition, it will try for ignition up to three times before going into lockout with the standard ignition module. If the heater is equipped with the optional single-try ignition module, it will go into lockout.
5. Wait until the controller indicates 100% on the firing rate display screen (approximately 30 seconds).

**APPROVED**

**Blower Check**

1. Check blower suction using the manometer attached to the air pressure tee (connection “C”) as shown in **Figure 59**, with the heater firing at 100% input. The reading should be as noted in **Table AE** for both natural and propane gas.

**NOTE:** Retain the black plastic cap removed to install the manometer. It needs to be replaced when the manometer is removed.

**NOTE:** Technician performing initial start-up must carry a calibrated combustion analyzer to ensure desired combustion levels are achieved.

2. CO<sub>2</sub> and CO levels must be checked at 100% fire rate. When firing at 100%, the desired heater combustion CO<sub>2</sub> is 8.3 to 8.8% for natural gas and 9.5 to 10.0% for propane gas with CO less than 100 ppm. If this combustion cannot be achieved with the blower suction within the tolerances specified in **Table AE**, contact the factory.
3. CO<sub>2</sub> and CO levels must be checked at minimum fire. When firing at minimum fire, the desired heater combustion CO<sub>2</sub> is 7.5 to 8.5% for natural gas and 9.0 to 10.0% for propane gas with CO less than 100 ppm. If CO<sub>2</sub> values are not within the ranges specified; and if CO is above 100 ppm in either case, stop running the unit and contact your factory representative.

**⚠ WARNING:** Improper installation, adjustment, alteration, service or maintenance can cause property damage, personal injury, exposure to hazardous materials or loss of life.

**⚠ WARNING:** The unit has been factory tested and pre-certified at the reference gas pressure as shown on the unit decal. If the desired CO<sub>2</sub> and CO values are not achieved at the listed air pressure in Table AE within tolerance specified, contact your local manufacturer Representative or factory for direction. Tampering with preset values can lead to poor performance of the unit and result in personal injury, death or property damage.

4. If the CO<sub>2</sub> values and air pressure values (**Table AE**) are outside of the tolerances noted, the air shutter should be adjusted slightly to bring the values back into the nominal range. See **Figure 2** for location of the air shutter below the blower. Close the shutter slightly (clockwise) to increase the negative air pressure or raise the CO<sub>2</sub> values. Open shutter slightly (counter-clockwise) to lower the negative air pressure or lower the CO<sub>2</sub> values.

**Manifold Check**

1. Check manifold gas pressure on the gas valve pressure tap (connection “B” in **Figure 59**). Refer to **Table AF** for natural and propane gas pressure ranges and tolerances.
2. If the CO<sub>2</sub> ranges specified are not achieved with the pressure and tolerance ranges specified in **Table AF**, STOP – Call the your factory representative for directions on what to do next!

| Heater Size | Air Pressure Setting (in. WC) |             | Setting Tolerance |
|-------------|-------------------------------|-------------|-------------------|
|             | Natural Gas                   | Propane Gas |                   |
| 300         | -1.0                          | -1.1        | +/-0.2 in.WC      |
| 400         | -1.7                          | -1.9        | +/-0.2 in.WC      |
| 500         | -1.8                          | -2.1        | +/-0.2 in.WC      |
| 650         | -0.6                          | -0.7        | +/-0.1 in.WC      |
| 800         | -1.1                          | -1.1        | +/-0.2 in.WC      |
| 1000        | -1.8                          | -1.9        | +/-0.2 in.WC      |

**Table AF. Heater Air Pressure Settings**

| Heater Size | Gas Manifold Pressure (in. WC) |             | Setting Tolerance |
|-------------|--------------------------------|-------------|-------------------|
|             | Natural Gas                    | Propane Gas |                   |
| 300         | -1.0                           | -1.2        | +/-0.2 in.WC      |
| 400         | -1.7                           | -2.0        | +/-0.2 in.WC      |
| 500         | -1.8                           | -2.1        | +/-0.2 in.WC      |
| 650         | -1.0                           | -0.6        | +/-0.2 in.WC      |
| 800         | -0.8                           | -1.2        | +/-0.2 in.WC      |
| 1000        | -1.0                           | -1.6        | +/-0.2 in.WC      |

**Table AG. Heater Manifold Pressure Settings**

**⚠ CAUTION:** Special manifold and air settings may be required.

**User Test**

Set DIP switch #1 on the VERSA IC<sup>®</sup> to “ON”. On Touchscreen, click Menu icon, Tools icon, Systems Tools. Press “Start” to initiate User Test sequence.

- User Test START is displayed.
- Pressing Hold/Skip button advance through the user test.
- The Boil MIN/MAX steps for burner operation are only run for enabled heaters.
- Local Heat/DHW/EMS demands must be present for burner operation.

| Number Field | Output Action                         |
|--------------|---------------------------------------|
| SYS          | System Pump relay turns on            |
| DHW          | DHW Pump relay turns on               |
| PMP 1        | System and Heater Pump relays turn on |
| CWP          | CWP Proportional output               |
| Boil 1       | Ignite Heater Burner                  |
| Min 1        | Hold Heater at Min Fire               |
| Max 1        | Ramp Heater to Max Fire and hold      |

**Table AH. User Test Fields**

- On the first press of the Hold/Skip button, the test step is held and "HOLD" is flashed at 1Hz.
- On the second press of the Hold/Skip button, the test step is incremented.
- If heater outlet temperature reaches the PIM Hi-Limit, the heater will be ramped down to keep the temperature in a safe range.
- Press of the Hold/Skip button from Heater Max will End the User Test function.
- CWP MUST be enabled (VERSA DIP #3) VALVE must be functioning during USER TEST.

**NOTE:** If USER TEST is performed with Cold Water Protection enabled (VERSA DIP 3 = ON), allow valve or VS pump test sequence to complete uninterrupted or a fault condition may occur.

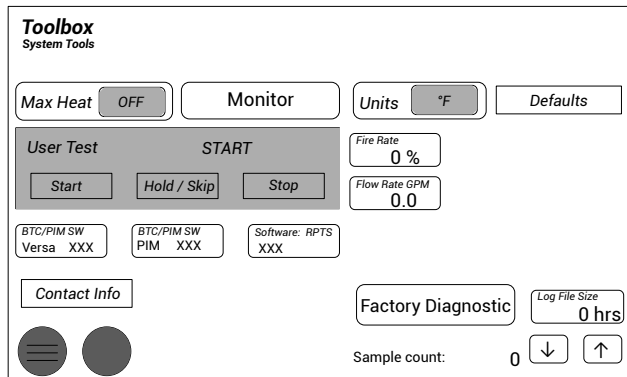

**Figure 60. Touchscreen Toolbox Menu**

### Safety Inspection

1. Check all thermostats and high-limit settings.
2. During the following safety checks leave manometers hooked up, check and record.
3. If other gas-fired appliances in the room are on the same gas main, check all pressures on the heater with all other equipment running.
4. Check thermostats for ON-OFF operation.
5. Check high-limits for ON-OFF operation.

6. While in operation, check flow switch operation.
7. Check the low gas pressure switch (if provided). (For proper adjustment, use the attached manometers, if available, to set pressure. The scales on the switch are approximate only.) Low gas pressure switch (if provided) must be set at 3" WC for natural gas and propane gas.
8. Make sure that the high gas pressure switch is set to 3" WC for both natural gas and propane gas.

### Finishing

Record all data on the "Start-up Checklist" located at the back of this manual.

Disconnect the manometers and reconnect the cap on the fan pressure tee and reinsert the sealing screws into the bleedle valves.

Start-up is complete and the heater should be operating properly.

### Follow-Up

Safety checks must be recorded as performed.

Turn heater on. After main burner ignition:

1. Check manometer for proper readings.
2. Cycle heater several times and re-check readings.
3. Remove all manometers and replace caps and screws.
4. Check for gas leaks one more time.
5. To prepare for possible "limp-along" operation (if communication is ever lost between the VERSA and the PIM), set the operator setpoint potentiometer on the PIM (Refer to VERSA IC<sup>®</sup> Manual (241493) for details.)

### Leak Test Procedure: Dual-Seat Gas Valve

Proper leak testing requires three pressure test points in the gas train. Remove the upper front panel to access the gas valve for this test. See **Figure 59**.

Test point A is a bleedle valve located upstream of the combination gas valve on the supply manifold.

Test point B is a bleedle valve located between the two automatic gas valve seats.

Test point C is a bleedle valve located downstream of both automatic gas valve seats and upstream of the manual valve. See **Figure 61**.

These tests are to be conducted with the electrical power to the heater turned OFF.

1. Manually close the downstream leak test valve.
2. Open the bleedle valve at test point A and connect a manometer to it. Verify that there is gas pressure and that it is within the proper range (NOTE: must not exceed 14" WC).



**APPROVED**

3. Open test point B and connect a rubber tube to it. Connect the other end of the tube to a manometer and look for a build-up of pressure. Increasing pressure indicates a leaking gas valve which must be replaced.
4. Next, close the upstream manual gas valve (field-supplied) and remove the manometers from the bleedle valves in test point A and test point B. Connect a rubber tube from the test point A bleedle valve to the test point B bleedle valve and open the upstream manual gas valve. Make sure that test point A and B bleedle valves have been opened so as to allow gas to flow. This will bring gas pressure to the second valve seat.
5. Open the bleedle valve at test point C and connect a second rubber tube to it. Connect the other end of the tube to a manometer and look for a build-up of pressure. Increasing pressure indicates a leaking gas valve which must be replaced.
6. Remove rubber tube and manometers. Close each bleedle valve as the tubes are removed.
7. After no leakage has been verified at all valve seats and test valve, open downstream leak test valve and restore electrical power to the heater.
6. Inspect burner to verify flame.
7. Test safety controls: test low water cut-off or additional safety controls for operation as outlined by manufacturer. Burner should be operating and should go off when controls are tested. When safety devices are restored, burners should re-ignite after pre-purge time delay.
8. To test the fixed manual-reset high-limit built into the PIM, first set DIP switch #8 on the PIM to the ON position. This will activate a Commission Test Mode which will turn on the amber Alarm/Test LED on the PIM. The fixed high-limit setting is temporarily overridden to match the setpoint potentiometer position on the PIM. The high-limit can now be adjusted by the potentiometer to assist in commission testing and verification of high-limit functionality. The VERSA IC<sup>®</sup> will allow one-time operation of the limit and then must be returned to normal operation by turning DIP switch #8 back to the OFF position. Power to the unit must then be cycled off, then on to return to normal operation.
9. Test ignition system safety device:
  - a. Close downstream manual gas valve. See **Figure 61**. Turn power on.
  - b. Close Enable/Disable circuit to call-for-heat.
  - c. The burner should attempt three trials for ignition for the standard model and then lock out. Single-try ignition modules will try only once and then lock out.
  - d. Open manual gas valve. Reset the ignition control by pressing for one second and then releasing the reset button adjacent the user interface or at the PIM to clear the ignition fault.
10. To restart system, follow lighting instructions in the Operation section.
11. Check to see that the high-limit control is set above the design temperature requirements of the system. For multiple zones: Check to make sure the flow is adjusted as required in each zone.
12. Check that the heater is cycled with the thermostat. Raise the setting on the thermostat to the highest setting and verify that the heater goes through the normal start-up cycle. Reduce to the lowest setting and verify that the heater goes off.
13. Observe several operating cycles for proper operation.
14. Set the heater thermostat to desired temperature.
15. Review all instructions shipped with this heater with owner or maintenance person, return to envelope and give to owner or place the instructions inside front panel on heater.

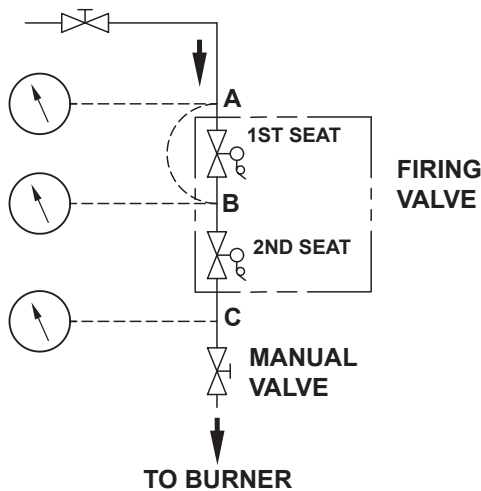

**Figure 61. Leak Test Procedure**

**Post Start-Up Check**

Check off steps as completed:

1. Verify that the heater and heat distribution units are filled with water.
2. Open the caps on automatic air vent valves during the venting procedure.
3. Verify that air has been purged from the system.
4. Verify that air has been purged from the gas piping, and that the piping has been checked for leaks.
5. Confirm that the proper start-up procedures were followed.



## 8. OPERATION

### Lighting Instructions

1. Before operation, make sure you have read all of the safety information in this manual.
2. Remove front panel.
3. Set the thermostat to the lowest setting.
4. Turn off all electrical power to the appliance.
5. This appliance is equipped with an ignition device which automatically lights the burner. Do not try to light the burner by hand.
6. Turn on main manual gas valve field-installed near gas inlet connection on back of heater.
7. Turn on all electrical power to the appliance.
8. Set thermostat to desired setting. The appliance will operate. The igniter will glow after the pre-purge time delay (15 seconds). After igniter reaches temperature (30 seconds) the main valve should open for a 4-second trial for ignition. System will try for ignition up to three times (one time on optional single-try ignition module). If flame is not sensed, lockout will commence.
9. If the appliance will not operate, follow the instructions "To Turn Off Gas To Appliance," and call your service technician or gas supplier.
10. Replace front panel.
11. If heater fails to start, verify the following:
  - a. There are no loose connections or that the service switch is off or in the powered, but disabled position.
  - b. High temperature limit switch (optional) is set above water temperature or manual-reset high-limit is not tripped.
  - c. Enable/Disable circuit is closed.
  - d. Gas is on at the meter and the heater.
  - e. Incoming dynamic gas pressure to the gas valve is NOT less than 4" WC for natural gas and 8" WC for propane gas.

### To Turn Off Gas To Appliance

1. Shut off manual gas valve field installed near gas inlet connection on back of heater.
2. Remove front panel.
3. Move 3-position rocker switch to "OFF" position.
4. Turn off all electrical power to the appliance if service is to be performed.
5. Replace access panel.

## Heater Status Light

The light operation status of the heater change as follows:

- White [Solid] - IDLE - Unit is powered on
- Blue [Pulsing] - PREPURGE/IGNITION - Call for heat
- Blue [Solid] - MODULATING - Burner is on
- White [Pulsing] - PREPURGE - Call for heat terminated
- Red [Pulsing] - ERROR - Operation error message displayed in touchscreen.

For error details please refer to the VERSA IC<sup>®</sup> Manual (241493).

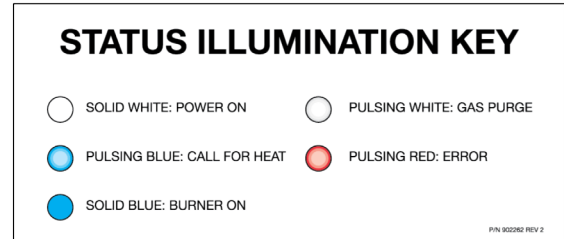

Figure 62. Touchscreen Illumination Key Screen

## 9. TROUBLESHOOTING

### Heater Error Codes

If any of the sensors detect an abnormal condition or an internal component fails during the operation of the heater, the display may show the error. This code may either be the result of a temporary condition in which case the display will revert to its normal readout when the condition is corrected, or it may be the result of a condition that the controller has evaluated as not safe to restart the unit. In this case, the unit control will be locked out, requiring the maintenance person to manually reset the control by pressing and releasing the button.

Error messages are displayed in touchscreen. For additional error details please refer to the VERSA IC<sup>®</sup> control Manual (241493).

### Heater Errors

When an error condition occurs, the controller will display an error code on the touch screen display. These error codes and several suggested corrective actions are included in the heater Fault Text section on the following page.

### Heater Faults

1. When a fault condition occurs, the controller will flash a red light on the PIM and display the error code on the user interface. The alarm output will also be activated. Most fault conditions will also cause the heater pump to run in an attempt to cool the unit.

**APPROVED**

2. Note the error code, either through the flash code on the PIM and/or from the Toolbox menu on the user interface, and reference the explanation of the fault along with troubleshooting steps in the heater fault text section.
3. Investigate and correct the cause of the fault.
4. Press and release the RESET key to clear the fault on the user interface and resume operation. Be sure to observe the operation of the unit for a period of time to ensure correct operation and no reoccurrence of fault code(s).

**NOTE:** It may be necessary to press RESET buttons on the specific safety control (e.g. optional adjustable manual-reset high-limit, low gas pressure switch, high gas pressure switch, low water cutoff, etc).

**⚠ DANGER:** When servicing or replacing components that are in direct contact with the water, be certain that:

- There is no pressure in the heater. (Pull the release on the relief valve. Do not depend on the pressure gauge reading).
- The heater water is not hot.
- The electrical power is off.

**⚠ WARNING:** When servicing or replacing any components of this unit be certain that:

- The gas is off.
- All electrical power is disconnected.

**⚠ WARNING:** Do not use this appliance if any part has been under water. Improper or dangerous operation may result. Contact a qualified service technician to inspect the heater and to repair or replace any part of the heater that has been under water prior to placing the heater back in operation.

**⚠ CAUTION:** Wiring errors can cause improper and dangerous operation. Verify proper operation after servicing. See wiring diagram.

**⚠ CAUTION:** If overheating occurs or the gas supply fails to shut off, do not turn off electrical power to the circulating pump. This may aggravate the problem and increase the likelihood of heater damage. Instead, shut off the gas supply to the heater at the gas service valve.

**Raymote Troubleshooting (Sales Order Option C-11 for XFire Models only)**

Please refer to the Raymote installation and operation Manual (241788).

**Heater Fault Text**

**Error Display**

If there is an active error, then it is displayed in multiple touchscreen views until the error is resolved. For additional error details please refer to the VERSA IC<sup>®</sup> control Manual (241493).

| Error Item   | Description and Troubleshooting   |
|--------------|---|
| OUTLET SEN   | Check the outlet water sensor and its wiring  |
| LIMIT SEN    | Check the high-limit sensor and its wiring  |
| INLET SEN    | Check the inlet sensor and its wiring   |
| GAS PRESS    | Check PIM wiring  |
| IGNITION     | Reset control, push and release RESET button  |
| LIMIT TRIP   | Heater temperature tripped the high-limit   |
| FLAME        | False flame detected. Shut off gas supply, recycle power                                    |
| ID CARD      | Identity card, check ID card and wiring   |
| IGN CTRL     | Internal control fault. Reset power, replace control  |
| DELTA T      | Temperature difference between the inlet and outlet exceeded the setpoint. Check water flow |
| LOW 24VAC    | Low 24 VAC power. Check power supply wiring and transformer                                 |
| BLOW SPEED   | Blower speed out of range. Check blower wiring and blower                                   |
| FLOW ERROR   | The unit is not detecting enough flow to allow ignition sequence to take place              |
| UNDER FLOW   | The flow reading has drop under minimum requirements to keep the current operation point    |
| FLOW WARNING | Operation conditions do not match current flow reading                                      |

Table A1. Error Display

**UNCONTROLLED DOCUMENT IF PRINTED**

**APPROVED**

**PIM LED Error Code Listing**

Active errors detected are indicated by LED lights on the PIM.

| <b>Error Mode</b>              | <b>LED Flash Code on PIM</b>              | <b>Recommended Troubleshooting</b>  |
|--------------------------------|---|---|
| Normal Operation               | Red LED OFF                               |   |
| ID Card Fault                  | Red LED Steady ON,<br>Green Power LED OFF | Check that the proper ID Card is securely connected. Perform a power and system reset   |
| Internal Control Fault         | Red LED Steady ON                         | Perform a power and system reset. If the fault remains, replace the PIM   |
| N/A                            | Red LED – 1 Flash                         |   |
| False Flame Error              | Red LED – 2 Flashes                       | Check for proper gas valve closure. Clean burner and electrodes   |
| Ignition Lockout Fault         | Red LED – 3 Flashes                       | Check the gas supply. Check transformer. Check igniters. Check wiring. Press reset button on PIM/membrane switch. Recycle power                               |
| Ignition Proving Current Fault | Red LED – 4 Flashes                       | Check DSI element. Replace as necessary   |
| Low Voltage Fault              | Red LED – 5 Flashes                       | Check the 24VAC input voltage – the voltage must be above 18.0VAC for proper operation. Replace transformer as necessary                                      |
| N/A                            | Red LED – 6 Flashes                       | N/A   |
| Hi-Limit Fault                 | Red LED – 7 Flashes                       | Check for proper water flow. Check hi-limit setting and outlet sensor   |
| Sensor Fault                   | Red LED – 8 Flashes                       | Check the VERSA IC <sup>®</sup> for fault identification. Check sensor and wiring   |
| N/A                            | Red LED – 9 Flashes                       | Check wiring at J8, pins 1 and 3 for loose or missing jumper  |
| Water Pressure Fault           | Red LED – 10 Flashes                      | Check system piping for leaks. Check water pressure switch (if equipped) and connections. Check wiring on PIM at J1, pins 6 and 7 for loose or missing jumper |
| Blower Speed Fault             | Red LED – 11 Flashes                      | Verify the tachometer signal and the connections at terminals J10 on the PIM. Confirm power to heater is at or above minimum required                         |
| N/A                            | Red LED – 12 Flashes                      | Check wiring on PIM at J1, pins 3 and 4 for loose or missing jumper   |
| Hi-Temperature Delta Fault     | Red LED – 13 Flashes                      | Check pumps operation. Confirm proper water flow across heat exchanger (Delta T)  |
| Ft_bus Communications Fault    | Red LED – 14 Flashes                      | Verify that the VERSA IC <sup>®</sup> is connected and operating properly. Check the cable between the PIM and the VERSA IC <sup>®</sup>                      |
| General limit circuit fault    | Red LED – 15 Flashes                      | Check the VERSA IC <sup>®</sup> for fault indication and troubleshooting information  |

**Table AJ. PIM LED Error Codes**

## APPROVED

### Daily

1. Check that the area where the heater is installed is free from combustible materials, gasoline, and other flammable vapors and liquids.
2. Check for and remove any obstruction to the flow of combustion or ventilation air to heater.

### Monthly

1. Check for piping leaks around pumps, mixing valves, relief valves, and other fittings. If found, repair at once. DO NOT use petroleum-based stop-leak compounds.
2. Visually inspect venting system for proper function, deterioration or leakage.
3. Visually inspect for proper operation of the condensate drain in the venting. If leaks are observed repair at once.
4. Check air vents for leakage.

### Yearly (Beginning of each Heating Season)

Schedule annual service by qualified service agency.

1. Visually check top of vent for soot. Call service person to clean. Some sediment at bottom of vent is normal.
2. Visually inspect venting system for proper function, deterioration or leakage. Ensure that condensate drain is inspected and ensure that condensate is being directed to appropriate condensate treatment system or drain, as required by local codes.
3. Check that area is free from combustible materials, gasoline, and other flammable vapors and liquids.
4. Follow pre-start-up check in the Start-up section.
5. Check flame strength signal as noted on display Remove and visually inspect the direct spark igniter and sensor for damage, cracking or debris build-up.
6. Check operation of safety devices. Refer to manufacturers' instructions.
7. Follow oil-lubricating instructions on pump (if required). Over-oiling will damage pump. Water-lubricated circulators do not need oiling.
8. To avoid potential of severe burn, DO NOT REST HANDS ON OR GRASP PIPES. Use a light touch; return piping will heat up quickly.
9. Check blower and blower motor.
10. Check for piping leaks around pumps, relief valves and other fittings. Repair, if found. DO NOT use petroleum-based stop-leak.

## Sensor Resistance Values

| Water Sensor / Outdoor Sensor |                   |
|-------------------------------|-------------------|
| Water Temperature             | Resistance (ohms) |
| 32°F (0°C)                    | 32550             |
| 41°F (5°C)                    | 25340             |
| 50°F (10°C)                   | 19870             |
| 59°F (15°C)                   | 15700             |
| 68°F (20°C)                   | 12490             |
| 77°F (25°C)                   | 10000             |
| 86°F (30°C)                   | 8059              |
| 95°F (35°C)                   | 6535              |
| 104°F (40°C)                  | 5330              |
| 113°F (45°C)                  | 4372              |
| 122°F (50°C)                  | 3605              |
| 131°F (55°C)                  | 2989              |
| 140°F (60°C)                  | 2490              |
| 149°F (65°C)                  | 2084              |
| 158°F (70°C)                  | 1753              |
| 167°F (75°C)                  | 1481              |
| 176°F (80°C)                  | 1256              |
| 185°F (85°C)                  | 1070              |
| 194°F (90°C)                  | 915               |
| 203°F (95°C)                  | 786               |
| 212°F (100°C)                 | 667               |

Table AK. Approximate Sensor Resistance Values

## 10. MAINTENANCE

### Suggested Minimum Maintenance Schedule

**▲ WARNING:** Only pH Power Pellets® can be used in JJM® treatment kits. Any other media, such as limestone or marble chips, is strictly prohibited. Failure to follow these instructions completely voids the manufacturer's limited warranty and could cause a safety hazard, severe personal injury, death or substantial property damage.

Regular service by a qualified service agency and maintenance must be performed to ensure maximum operating efficiency.

Daily and monthly maintenance as outlined below may be performed by onsite maintenance staff.

**APPROVED**

11. pH Power Pellets® must be replaced the sooner of (i) annually, or (ii) the pH level at the outlet of the neutralizer drops below 5.0 (or the minimum level of the local water authority).

**Periodically**

1. Check relief valve.
2. Test low water cut-off. (With heater in pre-purge, depress the low water cut-off test button. Appliance should shut-off and service light should come on. Depress reset button on front of junction box panel to reset).
3. Check and clean strainer in y-strainer or suction diffuser for debris, if equipped.
4. Clean the screens in the vent & air inlet terminals (as applicable)
5. Visual inspection of neutralizer (when applicable) for leaks or damage and replacement of the pH Power Pellets.

**Preventive Maintenance Schedule**

The following procedures are recommended and are good practice for all heater installations.

**Daily**

1. Check gauges, monitors and indicators.
2. Check instrument and equipment settings. See “Post Start-Up Check” on **page 60**.

**Weekly**

For low-pressure heaters, test low-water cut-off device.

**Monthly**

1. Check flue, vent, stack, or outlet dampers.
2. Test blower air pressure. See “Blower Check” on **page 58**.
3. Test high and low gas pressure interlocks, if equipped. See “Safety Inspection” on **page 59**.

**Semi-Annually**

1. Recalibrate all indicating and recording gauges.
2. Check flame failure detection system components.
3. Check firing rate control by checking the manifold pressure. See “Manifold Check” on **page 58**.
4. Check piping and wiring of all interlocks and shut-off valves.

**Annually**

1. Test flame failure detection system and pilot turndown.
2. Test high-limit and operating temperature. See “Post Start-Up Check,” **page 60**.

3. Check flame sensor.
4. Check flame signal strength. (Flame signal should be greater than 1 **microampere** as measured at the 2 pins on the bottom of the PIM).
5. Conduct a combustion test at full fire. CO<sub>2</sub> should be 8.3 to 8.8% at full fire for natural gas, and 9.5 to 10.0% for propane gas. CO should be less than 100 ppm.

**NOTE: Technician performing initial start-up must carry a calibrated combustion analyzer to ensure desired combustion levels are achieved.**

**⚠ WARNING: The unit has been factory tested and pre-certified at the reference gas pressure as shown on the unit decal. If the desired CO<sub>2</sub> and CO values are not achieved at the listed air pressure in Table AE within tolerance specified, contact your local manufacturer Representative or factory for direction. Tampering with preset values can lead to poor performance of the unit and result in personal injury, death or property damage.**

6. Check emission at minimum fire and record CO and CO<sub>2</sub> reading. CO must be less than 100 ppm for all fuels. CO<sub>2</sub> must be between 7.5 to 8.5% for natural gas, 9.0 to 10.0% for propane gas. If CO and CO<sub>2</sub> are not within these ranges, stop running the unit and contact your manufacturer representative.
7. Check valve coil for 60-cycle hum or buzz. Check for leaks at all valve fittings using a soapy water solution (while heater is operating). Test other operating parts of all safety shut-off and control valves and increase or decrease settings (depending on the type of control) until the safety circuit opens. Reset to original setting after each device is tested.
8. Perform leakage test on gas valves. See **Figure 61**.
9. Inspect and clean burner using shop air.

**⚠ CAUTION: Do not clean with water.**

10. Drain heat exchanger and inspect the water side visually for build up or debris by removing inlet stub pipe or suction diffuser inspection cover.



## As Required

1. Recondition or replace low water cut-off device.
2. Check sediment trap and gas strainers.
3. Check flame failure detection system. See "Post Start-Up Check," **page 60**.
4. Check igniter. Resistance reading should be 40-75 ohms at 77°F (25°C).
5. Check flame signal strength. (Flame signal should be greater than 1 **microampere** as measured at the 2 pins on the bottom of the PIM).
6. Check firing rate control by checking the manifold pressure. See "Manifold Check" on **page 58**.
7. Test safety relief valves in accordance with ASME Heater and Pressure Vessel Code Section IV.

## Air Filter Maintenance

- Inspect quarterly. Replace as needed. The recommended interval is once per year.

**NOTE:** Use factory replacement filters, for models 300-1000 kit number 012553F.



APPROVED

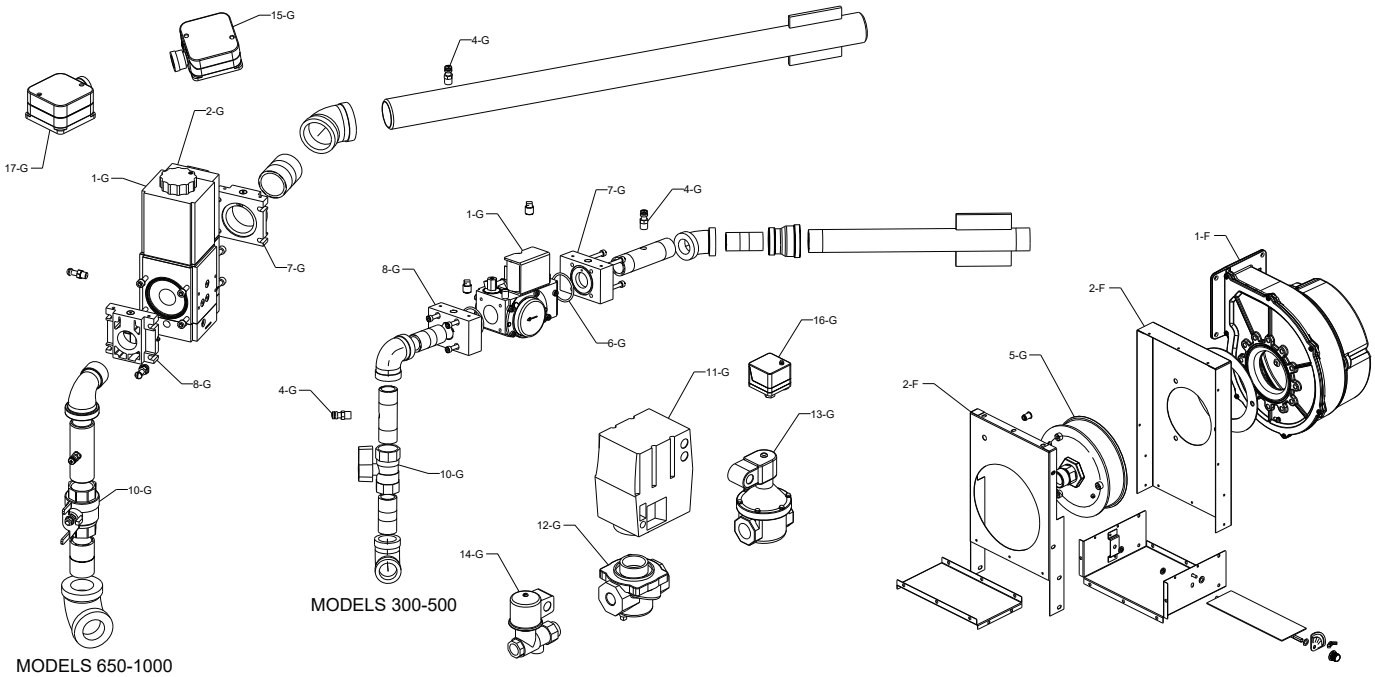
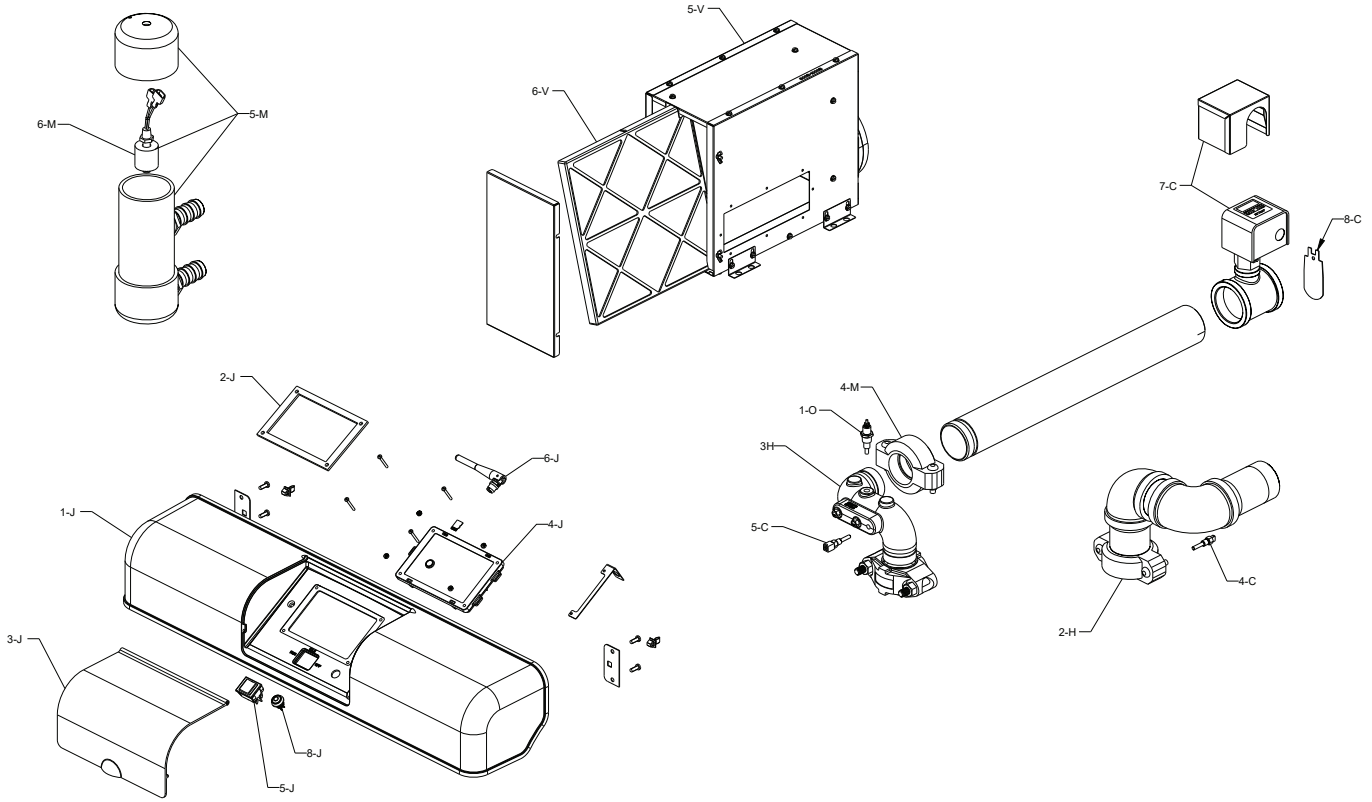

UNCONTROLLED DOCUMENT IF PRINTED

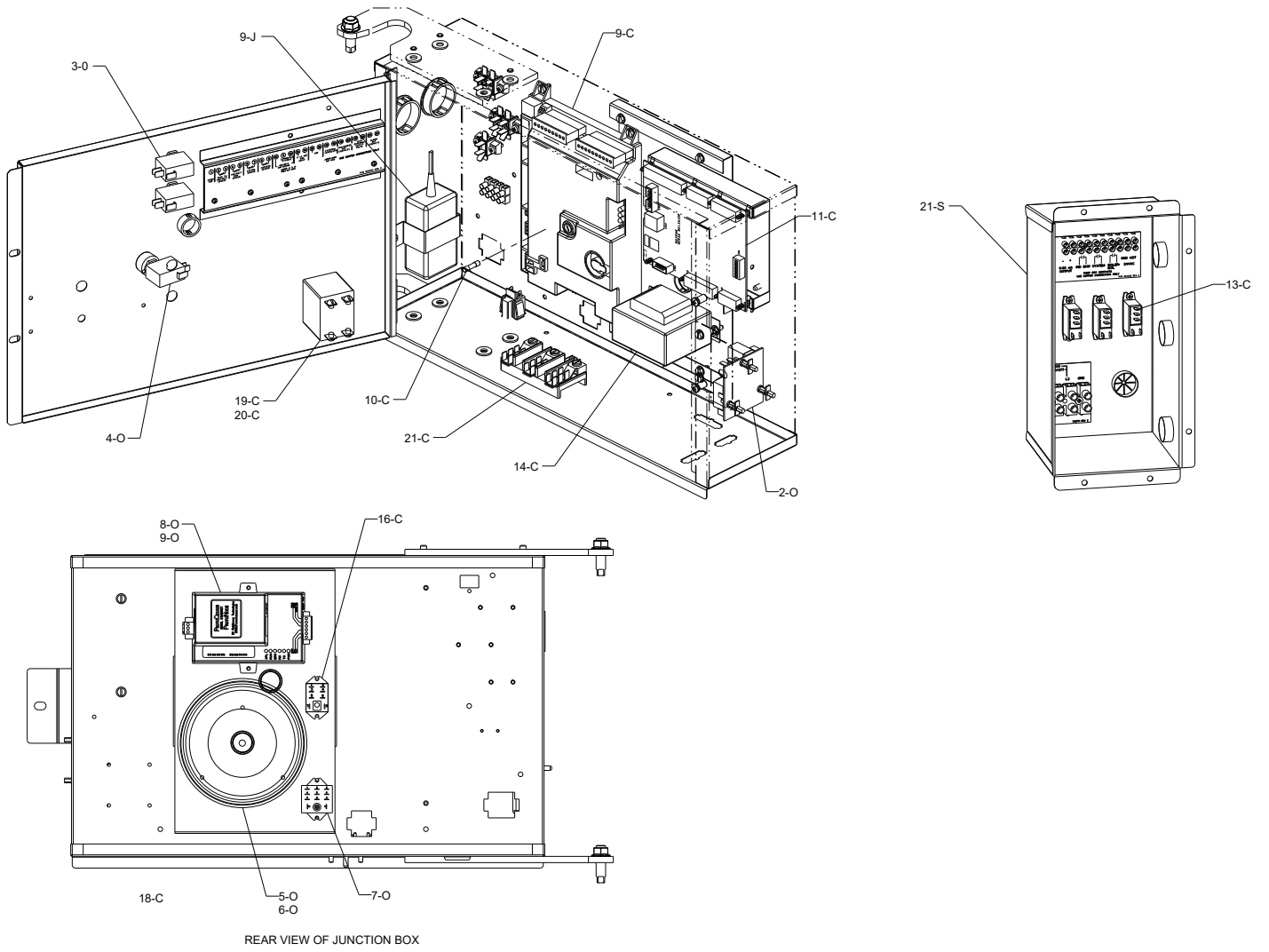

**APPROVED**

| CALL OUT | DESCRIPTION  | 300     | 400     | 500     | 650     | 800     | 1000    |
|----------|--|---------|---------|---------|---------|---------|---------|
| <b>B</b> | <b>BURNER ASSEMBLY</b>                             |         |         |         |         |         |         |
| 1-B      | Front Door Assembly                                | 017872F | 017872F | 017872F | 017872F | 017872F | 017872F |
| 2-B      | Front Door Insulation                              | 017873F | 017873F | 017873F | 017873F | 017873F | 017873F |
| 3-B      | Observation Port                                   | 017874F | 017874F | 017874F | 017874F | 017874F | 017874F |
| 4-B      | Igniter  | 017875F | 017875F | 017875F | 017875F | 017875F | 017875F |
|          | Bent Igniter (Propane Units Only)                  | 018814F | 018814F | 018814F | N/A     | N/A     | N/A     |
| 5-B      | Flame Sensor                                       | 017876F | 017876F | 017876F | 017876F | 017876F | 017876F |
| 6-B      | Burner Adapter                                     | 017877F | 017877F | 017878F | 017878F | 017879F | 017879F |
| 7-B      | Burner   | 017880F | 017880F | 017881F | 017882F | 017883F | 017884F |
| 8-B      | Flue Clamping Ring and Gasket                      | 017885F | 017885F | 017885F | 018257F | 018257F | 018257F |
| 9-B      | Insulation (Inside Rear of the Combustion Chamber) | 017887F | 017887F | 017887F | 017887F | 017887F | 017887F |
| <b>C</b> | <b>CONTROLS</b>                                    |         |         |         |         |         |         |
| 1-C      | Auto Reset Adjustable High Limit 180°F Max         | 006445F | 006445F | 006445F | 006445F | 006445F | 006445F |
|          | Auto Reset Adjustable High Limit 200°F Max         | 012546F | 012546F | 012546F | 012546F | 012546F | 012546F |
| 2-C      | Manual Reset Adjustable High Limit 180°F Max       | 009554F | 009554F | 009554F | 009554F | 009554F | 009554F |
|          | Manual Reset Adjustable High Limit 200°F Max       | 008081F | 008081F | 008081F | 008081F | 008081F | 008081F |
| 3-C      | Manual Reset Fixed High Limit 320°F                | 017899F | 017899F | 017899F | 017899F | 017899F | 017899F |
| 4-C      | Inlet Sensor (2 Wire)                              | 013175F | 013175F | 013175F | 013175F | 013175F | 013175F |
| 5-C      | Outlet Sensor (4 Wire)                             | 013932F | 013932F | 013932F | 013932F | 013932F | 013932F |
| 6-C      | Sensor Water 10K (Not Shown)                       | 010787F | 010787F | 010787F | 010787F | 010787F | 010787F |
| 7-C      | Flow Switch  | 007142F | 007142F | 007142F | 007142F | 007142F | 007142F |
| 8-C      | Flow Switch Paddle (Taco)                          | 010026F | 010026F | 010026F | 010026F | 010026F | 010026F |
| 9-C      | PIM (Platform Ignition Module) Multi-Try           | 017218F | 017218F | 017218F | 017218F | 017218F | 017218F |
|          | PIM (Platform Ignition Module) Single-Try          | 017219F | 017219F | 017219F | 017219F | 017219F | 017219F |
| 10-C     | Fuse 5 Amp (Fast Acting)                           | 013971F | 013971F | 013971F | 013971F | 013971F | 013971F |
| 11-C     | PC Board VERSA IC                                  | 013935F | 013935F | 013935F | 013935F | 013935F | 013935F |
| 12-C     | Blocked Vent Pressure Switch                       | 011760F | 011760F | 011760F | 011760F | 011760F | 011760F |
| 13-C     | Pump Relay 120Vac                                  | 017067F | 017067F | 017067F | 017067F | 017067F | 017067F |
| 14-C     | Transformer 115/24 VA                              | 007494F | 007494F | 007494F | 007494F | 007494F | 007494F |
| 15-C     | Fuse 3/4 Amp (Not Shown)                           | 017853F | 017853F | 017853F | 017853F | 017853F | 017853F |
| 16-C     | Relay DPDT 24V NO/NC                               | 011720F | 011720F | 011720F | 011720F | 011720F | 011720F |
| 17-C     | Transformer 208/120V 650VA                         | 017891F | 017891F | 017891F | 017891F | 017891F | 017891F |
| 18-C     | Contactors   | 009860F | 009860F | 009860F | 009860F | 009860F | 009860F |
| 19-C     | On/Off Circuit Breaker Switch 5.0 Amp              | 017833F | 017833F | 017833F | 017833F | N/A     | N/A     |
| 20-C     | On/Off Circuit Breaker Switch 7.5 Amp              | 017834F | 017834F | N/A     | N/A     | 017834F | 017834F |
| 21-C     | Terminal Block w/Ground Lug                        | 008523F | 008523F | 008523F | 008523F | 008523F | 008523F |
| <b>J</b> | <b>CONTROLS (Up Front)</b>                         |         |         |         |         |         |         |
| 1-J      | Control Bezel                                      | 017835F | 017835F | 017835F | 017835F | 017835F | 017835F |
| 2-J      | Gasket Touchscreen Display                         | 017837F | 017837F | 017837F | 017837F | 017837F | 017837F |
| 3-J      | Control Bezel Cover                                | 017836F | 017836F | 017836F | 017836F | 017836F | 017836F |
| 4-J      | Touchscreen Display PC Board                       | 017810F | 017810F | 017810F | 017810F | 017810F | 017810F |
| 4-J      | SD Card WiFi Disabled (XFiire) (Not Shown)         | 017811F | 017811F | 017811F | 017811F | 017811F | 017811F |
| 4-J      | SD Card WiFi Enabled (XFiire) (Not Shown)          | 018730F | 018730F | 018730F | 018730F | 018730F | 018730F |
| 4-J      | SD Card WiFi Disabled (IFire) (Not Shown)          | 019266F | 019266F | 019266F | 019266F | 019266F | 019266F |
| 5-J      | On/Off Switch                                      | 016795F | 016795F | 016795F | 016795F | 016795F | 016795F |
| 6-J      | WIFI ANTENNA                                       | 017198F | 017198F | 017198F | 017198F | 017198F | 017198F |
| 7-J      | Indicator LED Strip                                | 017812F | 017812F | 017812F | 017812F | 017812F | 017812F |
| 8-J      | Reset Switch Touchscreen                           | 015879F | 015879F | 015879F | 015879F | 015879F | 015879F |
| 9-J      | AC/DC Adapter                                      | 011719F | 011719F | 011719F | 011719F | 011719F | 011719F |
| <b>F</b> | <b>FAN</b>   |         |         |         |         |         |         |
| 1-F      | Blower Combustion Air                              | 018963F | 018963F | 018964F | 018964F | 018965F | 018965F |
| 2-F      | Plenum Assembly                                    | 017860F | 017860F | 017861F | 017862F | 017862F | 017862F |
| 3-F      | Hose Duct 4" (TruSeal)                             | 007417F | 007417F | 007417F | N/A     | N/A     | N/A     |
|          | Hose Duct 6" (TruSeal)                             | N/A     | N/A     | N/A     | 007418F | 007418F | 007418F |

**UNCONTROLLED DOCUMENT IF PRINTED**



**APPROVED**

| <b>CALL OUT</b> | <b>DESCRIPTION</b>   | <b>300</b> | <b>400</b> | <b>500</b> | <b>650</b> | <b>800</b> | <b>1000</b> |
|-----------------|--|------------|------------|------------|------------|------------|-------------|
| <b>G</b>        | <b>GAS TRAIN</b>   |            |            |            |            |            |             |
| 1-G             | Valve Gas Modulating 24V                                     | 013942F    | 013942F    | 013942F    | N/A        | N/A        | N/A         |
|                 | Valve Gas Modulating 120V                                    | N/A        | N/A        | N/A        | 016899F    | 016899F    | 016899F     |
| 2-G             | Valve Coil 120V  | N/A        | N/A        | N/A        | 013201F    | 013201F    | 013201F     |
| 3-G             | Inlet Gas Filter (Not Shown)                                 | N/A        | N/A        | N/A        | 012294F    | 012294F    | 012294F     |
| 4-G             | Bleedle Valve G1/8 BSP                                       | N/A        | N/A        | N/A        | 015400F    | 015400F    | 015400F     |
| 5-G             | Swirler  | 017971F    | 017971F    | 017972F    | 017870F    | 017871F    | 017871F     |
| 6-G             | O-rings (Includes Gas Valve and Adapter O-rings)             | 013203F    | 013203F    | 013203F    | 012440F    | 012440F    | 012440F     |
| 7-G             | Adapter Gas Valve 3/4" Inlet (Includes O-rings)              | 013204F    | 013204F    | 013204F    | N/A        | N/A        | N/A         |
|                 | Adapter Gas Valve 1-1/4" Inlet                               | N/A        | N/A        | N/A        | 011916F    | 011916F    | 011916F     |
| 8-G             | Adapter Gas Valve 3/4"Outlet (Includes O-rings)              | 013204F    | 013204F    | 013204F    | N/A        | N/A        | N/A         |
|                 | Adapter Gas Valve 1" Outlet Flow Control                     | N/A        | N/A        | N/A        | 013206F    | 013206F    | 013206F     |
| 9-G             | Nozzle Natural Gas (Not Shown)                               | 013944F    | 013944F    | N/A        | N/A        | N/A        | N/A         |
|                 | Nozzle Propane Gas (Not Shown)                               | 013944F    | 013944F    | N/A        | N/A        | N/A        | N/A         |
| 10-G            | Valve Gas Ball (WOG)   | 013208F    | 013208F    | 013208F    | 011769F    | 011769F    | 011769F     |
| 11-G            | Motorized Safety Shut Off Actuator M-1 (Optional)            | 011908F    | 011908F    | 011908F    | 011908F    | 011908F    | 011908F     |
| 12-G            | Gas Valve Body M1 (Optional)                                 | 014014F    | 014014F    | 014014F    | 014015F    | 014015F    | 014015F     |
| 13-G            | Solenoid Safety Shut Off Valve M-10 (Optional)               | 011909F    | 011909F    | 011909F    | 011909F    | 011909F    | 011909F     |
| 14-G            | Vent Valve Gas M-15 (Optional)                               | 011913F    | 011913F    | 011913F    | 011913F    | 011913F    | 011913F     |
| 15-G            | Switch Low Gas Pressure (Optional)                           | 011770F    | 011770F    | 011770F    | 011770F    | 011770F    | 011770F     |
| 16-G            | Switch Low Gas Pressure w/M-1 or M-10 (Optional) (Not Shown) | 007187F    | 007187F    | 007187F    | 007187F    | 007187F    | 007187F     |
| 17-G            | Switch High Gas Pressure (Optional)                          | 011771F    | 011771F    | 011771F    | 011771F    | 011771F    | 011771F     |
| <b>H</b>        | <b>HEAT TRANSFER</b>   |            |            |            |            |            |             |
| 1-H             | Heat Engine (Complete with Burner and Sensors)               | 017865F    | 017865F    | 017866F    | 017867F    | 017868F    | 017869F     |
| 2-H             | Plumbing Assy Inlet  | 017889F    | 017889F    | 017889F    | 017889F    | 017889F    | 017890F     |
| 3-H             | Plumbing Assy Outlet   | 017894F    | 017894F    | 017895F    | 017896F    | 017897F    | 017898F     |
| 4-H             | Drain Valve  | 006536F    | 006536F    | 006536F    | 006536F    | 006536F    | 006536F     |
| <b>M</b>        | <b>MISCELLANEOUS COMPONENTS</b>                              |            |            |            |            |            |             |
| 1-M             | T & P Gauge 0-90 PSI   | 007205F    | 007205F    | 007205F    | 007205F    | 007205F    | 007205F     |
|                 | T & P Gauge 0-200 PSI  | 007399F    | 007399F    | 007399F    | 007399F    | 007399F    | 007399F     |
| 2-M             | PRV 30 PSI   | 007470F    | 007470F    | 007217F    | 007218F    | 007218F    | 007748F     |
|                 | PRV 45 PSI   | 007220F    | 007220F    | 007220F    | 007346F    | 007346F    | 007221F     |
|                 | PRV 60 PSI   | 007222F    | 007222F    | 007222F    | 007222F    | 007222F    | 007222F     |
|                 | PRV 75 PSI   | 007223F    | 007223F    | 007223F    | 007223F    | 007223F    | 007223F     |
|                 | PRV 125 PSI  | 007224F    | 007224F    | 007224F    | 007224F    | 007224F    | 007224F     |
|                 | PRV 150 PSI  | 007225F    | 007225F    | 007225F    | 007225F    | 007225F    | 007225F     |
| 3-M             | RTV Sealant 2.8 oz (Not Shown)                               | 008924F    | 008924F    | 008924F    | 008924F    | 008924F    | 008924F     |
|                 | RTV Sealant 10 oz (Not Shown)                                | 005755F    | 005755F    | 005755F    | 005755F    | 005755F    | 005755F     |
| 4-M             | Water Connection Clamps                                      | 017900F    | 017900F    | 017900F    | 017900F    | 017900F    | 017901F     |
| 5-M             | Condensate Trap  | 017902F    | 017902F    | 017902F    | 017902F    | 017902F    | 017902F     |
| 6-M             | Condensate Float Switch NC                                   | 013947F    | 013947F    | 013947F    | 013947F    | 013947F    | 013947F     |
| 7-M             | Condensate Hose  | 013948F    | 013948F    | 013948F    | 017970F    | 017970F    | 017970F     |
| 8-M             | Condensate Management  | 017726     | 017726     | 017726     | 017726     | 017726     | 017726      |
| 9-M             | Touch-up Paint   |            |            |            |            |            |             |
|                 | Maroon   | 750265     | 750265     | 750265     | 750265     | 750265     | 750265      |
|                 | Cool Dark Gray   | 750256     | 750256     | 750256     | 750256     | 750256     | 750256      |
| 10-M            | Wire Harness Cabinet (Not Shown)                             | 017903F    | 017903F    | 017903F    | 017904F    | 017905F    | 017905F     |
| 11-M            | Spark Cable High Tension Harness (Not Shown)                 | 017864F    | 017864F    | 017864F    | 017864F    | 017864F    | 017864F     |
| 12-M            | Versa IC Communication Cable (Not Shown)                     | 015556F    | 015556F    | 015556F    | 015556F    | 015556F    | 015556F     |
| 13-M            | Identification Card Harness (Not Shown)                      | 016715F    | 016715F    | 016715F    | 016715F    | 016715F    | 016715F     |
| 14-M            | Barbed Sample Connector                                      | 017911F    | 017911F    | 017911F    | 017911F    | 017911F    | 017911F     |
| 15-M            | Plastic Handle   | 012681F    | 012681F    | 012681F    | 012681F    | 012681F    | 012681F     |
| 16-M            | Air Inlet Gasket   | 017907F    | 017907F    | 017907F    | 017908F    | 017908F    | 017908F     |

**APPROVED**

| CALL OUT | DESCRIPTION                                    | 300     | 400     | 500     | 650     | 800     | 1000    |
|----------|--|---------|---------|---------|---------|---------|---------|
| <b>O</b> | <b>OPTIONS</b>                                 |         |         |         |         |         |         |
| 1-O      | Remote Sensor (LWCO)                           | 007228F | 007228F | 007228F | 007228F | 007228F | 007228F |
| 2-O      | Control PC Board (LWCO)                        | 007157F | 007157F | 007157F | 007157F | 007157F | 007157F |
| 3-O      | Test / Reset Switch (LWCO)                     | 005641F | 005641F | 005641F | 005641F | 005641F | 005641F |
| 4-O      | Silencer/Reset Switch (Alarm)                  | 005641F | 005641F | 005641F | 005641F | 005641F | 005641F |
| 5-O      | Alarm Bell 24V (4")                            | 017963F | 017963F | 017963F | 017963F | 017963F | 017963F |
| 6-O      | Alarm Buzzer 24V                               | 017964F | 017964F | 017964F | 017964F | 017964F | 017964F |
| 7-O      | Relay 3PDT 24 VAC (Alarm)                      | 014717F | 014717F | 014717F | 014717F | 014717F | 014717F |
| 8-O      | Gateway BACnet Interface Module B-85           | 016617F | 016617F | 016617F | 016617F | 016617F | 016617F |
| 9-O      | Gateway LonWorks Interface Module B-86         | 016618F | 016618F | 016618F | 016618F | 016618F | 016618F |
| <b>P</b> | <b>PUMPS</b>                                   |         |         |         |         |         |         |
| 1-P      | Pump Inline Cast Iron Boiler                   | N/A     | N/A     | N/A     | 007232F | 007232F | 007233F |
|          | Pump Inline BR Boiler                          | N/A     | N/A     | N/A     | 007226F | 007226F | 007227F |
|          | Pump Inline SS Boiler                          | 016477F | 016477F | 016477F | N/A     | N/A     | N/A     |
|          | Pump Inline BR Soft Water Heater               | N/A     | N/A     | N/A     | 007226F | 007226F | 007227F |
|          | Pump Inline SS Soft Water Heater               | 016477F | 016477F | 016477F | N/A     | N/A     | N/A     |
|          | Pump Inline BR Medium Water Heater             | N/A     | 007226F | 007347F | 007347F | 007347F | 011845F |
|          | Pump Inline SS Medium Water Heater             | 016477F | N/A     | N/A     | N/A     | N/A     | N/A     |
| 2-P      | Pump Cartridge 0012 (Not Shown)                | 016480F | 016480F | 016480F | N/A     | N/A     | N/A     |
| 3-P      | Pump Flange Gasket 0012                        | 008747F | 008747F | 008747F | N/A     | N/A     | N/A     |
| 4-P      | Pump Flange Gasket 1611                        | N/A     | N/A     | N/A     | 008749F | 008749F | 013423F |
| <b>S</b> | <b>SHEET METAL</b>                             |         |         |         |         |         |         |
| 1-S      | Jacket Top                                     | 017912F | 017912F | 017912F | 017913F | 017913F | 017914F |
| 2-S      | Front Door Assy                                |         |         |         |         |         |         |
|          | XFire Only                                     | 017915F | 017915F | 017915F | 017915F | 017915F | 017915F |
|          | IFire Only                                     | 019041F | 019041F | 019041F | 019041F | 019041F | 019041F |
| 3-S      | Jacket Side Panel                              | 017916F | 017916F | 017916F | 017917F | 017917F | 017918F |
| 4-S      | Jacket Rear Panel                              | 017919F | 017919F | 017919F | 017920F | 017920F | 017921F |
| 5-S      | Access Panel Rear Wiring Box                   | 017922F | 017922F | 017922F | 017922F | 017922F | 017922F |
| 6-S      | Access Panel Outlet Water                      | 017923F | 017923F | 017923F | 017923F | 017923F | 017924F |
| 7-S      | Access Panel Inlet Water                       | 017925F | 017925F | 017925F | 017925F | 017925F | 017926F |
| 8-S      | Access Panel Intake Air                        | 017927F | 017927F | 017927F | 017928F | 017928F | 017928F |
| 9-S      | Access Panel Flue Sensor                       | 017929F | 017929F | 017929F | 017930F | 017930F | 017930F |
| 10-S     | Control Bezel Mtg Panel                        | 017931F | 017931F | 017931F | 017931F | 017931F | 017931F |
| 11-S     | LED Light Bar Mtg Panel                        | 017932F | 017932F | 017932F | 017932F | 017932F | 017932F |
| 12-S     | Vertical Cabinet Inner Corner Support          | 017933F | 017933F | 017933F | 017933F | 017933F | 017933F |
| 13-S     | Vertical Cabinet Middle Support                | N/A     | N/A     | N/A     | 017934F | 017934F | 017934F |
| 14-S     | Vertical Cabinet Front Corner Support          | 017935F | 017935F | 017935F | 017935F | 017935F | 017935F |
| 15-S     | Left Side Horizontal Support                   | 017936F | 017936F | 017936F | 017937F | 017937F | 017938F |
| 16-S     | Right Side Horizontal Support                  | 017939F | 017939F | 017939F | 017940F | 017940F | 017941F |
| 17-S     | Heat Engine Upper Support LT                   | 017942F | 017942F | 017942F | 017942F | 017942F | 017943F |
| 18-S     | Heat Engine Upper Support RT                   | 017944F | 017944F | 017944F | 017944F | 017944F | 017944F |
| 19-S     | Transformer Cover Assy                         | 017945F | 017945F | 017945F | 017945F | 017945F | 017945F |
| 20-S     | Intake Air Flange (TruSeal)                    | 017946F | 017946F | 017946F | 017947F | 017947F | 017947F |
| 21-S     | Rear Wiring Box                                | 017948F | 017948F | 017948F | 017948F | 017948F | 017948F |
| 22-S     | Upper Rear Support                             | 017886F | 017886F | 017886F | 017886F | 017886F | 017886F |
| 23-S     | Cascade Mtg Bracket                            | 017888F | 017888F | 017888F | 017888F | 017888F | 017888F |
| <b>V</b> | <b>VENTING</b>                                 |         |         |         |         |         |         |
| 1-V      | Outdoor Vent Termination Tee (Stainless Steel) | 017754  | 017754  | 017754  | 017755  | 017755  | 017755  |
| 2-V      | Vent Termination Screen For Plastic Vent Tee   | 013283F | 013283F | 013283F | 013284F | 013284F | 013284F |
| 3-V      | Flue Exhaust Adapter                           |         |         |         |         |         |         |
|          | Polypropylene Venting                          | 017805  | 017805  | 017805  | 017806  | 017806  | 017806  |
|          | Stainless Steel Venting                        | 017968F | 017968F | 017968F | 017969F | 017969F | 017969F |
| 4-V      | Vent Limit Switch Manual Reset                 | 016761F | 016761F | 016761F | 016761F | 016761F | 016761F |
| 5-V      | Intake Air Filter Box                          | 017949F | 017949F | 017950F | 017951F | 017952F | 017952F |
| 6-V      | Air Filter Media                               | 012553F | 012553F | 012553F | 012553F | 012553F | 012553F |
| 7-V      | Outlet Gasket 4" Flue (Not Shown)              | 017885F | 017885F | 017885F | N/A     | N/A     | N/A     |
| 8-V      | Outlet Gasket 6" Flue (Not Shown)              | N/A     | N/A     | N/A     | 018257F | 018257F | 018257F |
| 9-V      | Vertical Vent Support (Not Shown)              | 018027F | 018027F | 018027F | 018027F | 018027F | 018027F |
|          | <b>Propane Conversion Kits*</b>                |         |         |         |         |         |         |
|          | Gas Conversions                                |         |         |         |         |         |         |
|          | Nat to Pro. DSI Pilot                          | 019003F | 019003F | 019003F | 018302F | 018302F | 018302F |

## 12. IMPORTANT INSTRUCTIONS FOR THE COMMONWEALTH OF MASSACHUSETTS

The Commonwealth of Massachusetts requires compliance with regulation 248 CMR 4.00 and 5.00 for installation of through-the-wall vented gas appliances as follows:

(a) For all side wall horizontally-vented gas-fueled equipment installed in every dwelling, building or structure used in whole or in part for residential purposes, including those owned or operated by the Commonwealth and where the side wall exhaust vent termination is less than seven (7) feet above finished grade in the area of the venting, including but not limited to decks and porches, the following requirements shall be satisfied:

### 1. INSTALLATION OF CARBON MONOXIDE DETECTORS.

At the time of installation of the side wall horizontally-vented gas-fueled equipment, the installing plumber or gasfitter shall observe that a hard-wired carbon monoxide detector with an alarm and battery back-up is installed on the floor level where the gas equipment is to be installed. In addition, the installing plumber or gasfitter shall observe that a battery-operated or hard-wired carbon monoxide detector with an alarm is installed on each additional level of the dwelling, building or structure served by the side wall horizontal vented gas-fueled equipment. It shall be the responsibility of the property owner to secure the services of qualified licensed professionals for the installation of hard-wired carbon monoxide detectors

a. In the event that the side wall horizontally-vented gas-fueled equipment is installed in a crawl space or an attic, the hard-wired carbon monoxide detector with alarm and battery back-up may be installed on the next adjacent floor level.

b. In the event that the requirements of this subdivision can not be met at the time of completion of installation, the owner shall have a period of thirty (30) days to comply with the above requirements; provided, however, that during said thirty (30) day period, a battery-operated carbon monoxide detector with an alarm shall be installed.

2. APPROVED CARBON MONOXIDE DETECTORS. Each carbon monoxide detector as required in accordance with the above provisions shall comply with NFPA 720 and be ANSI/UL 2034 listed and IAS certified.

3. SIGNAGE. A metal or plastic identification plate shall be permanently mounted to the exterior of the building at a minimum height of eight (8) feet above grade directly in line with the exhaust vent terminal for the horizontally-vented gas-fueled heating appliance or equipment. The sign shall read, in print size no less than one-half (1/2) inch in size, "GAS VENT DIRECTLY BELOW. KEEP CLEAR OF ALL OBSTRUCTIONS".

4. INSPECTION. The state or local gas inspector of the side wall horizontally-vented gas-fueled equipment shall not approve the installation unless, upon inspection, the inspector observes carbon monoxide detectors and signage installed in accordance with the provisions of 248 CMR 5.08(2)(a)1 through 4.

(b) EXEMPTIONS: The following equipment is exempt from 248 CMR 5.08(2)(a)1 through 4:

1. The equipment listed in Chapter 10 entitled "Equipment Not Required To Be Vented" in the most current edition of NFPA 54 as adopted by the Board; and

2. Product Approved side wall horizontally-vented gas-fueled equipment installed in a room or structure separate from the dwelling, building or structure used in whole or in part for residential purposes.

(c) MANUFACTURER REQUIREMENTS - GAS EQUIPMENT VENTING SYSTEM PROVIDED. When the manufacturer of Product Approved side wall horizontally-vented gas equipment provides a venting system design or venting system components with the equipment, the instructions provided by the manufacturer for installation of the equipment and the venting system shall include:

1. Detailed instructions for the installation of the venting system design or the venting system components; and

2. A complete parts list for the venting system design or venting system.

(d) MANUFACTURER REQUIREMENTS - GAS EQUIPMENT VENTING SYSTEM NOT PROVIDED. When the manufacturer of a Product Approved side wall horizontally-vented gas-fueled equipment does not provide the parts for venting the flue gases, but identifies "special venting systems", the following requirements shall be satisfied by the manufacturer:

1. The referenced "special venting system" instructions shall be included with the appliance or equipment installation instructions; and

2. The "special venting systems" shall be Product Approved by the Board, and the instructions for that system shall include a parts list and detailed installation instructions.

(e) A copy of all installation instructions for all Product Approved side wall horizontally-vented gas-fueled equipment, all venting instructions, all parts lists for venting instructions, and/or all venting design instructions shall remain with the appliance or equipment at the completion of the installation.

### GAS PRESSURE SUPERVISION

The Commonwealth of Massachusetts requires listed high and low gas pressure switches (manual-reset) for any model with a maximum firing input greater than 1,000,000 Btu/Hr in accordance with 248 CMR 7.04(11)(d).

A gas pressure regulator (field-supplied) is required in the gas train ahead of the heater, for heaters having input rates greater than 1,000,000 Btu/Hr, in accordance with 248 CMR 7.04 Figure 3B requirements.

# 13. START-UP CHECKLIST

APPROVED

This start-up checklist is to be completely filled out by the service technician starting up the heaters for the first time. All information may be used for warranty purposes and to ensure that the installation is correct. Additionally this form will be used to record all equipment operation functions and required settings.

## GAS SUPPLY DATA

Regulator Model & Size \_\_\_\_\_ / \_\_\_\_\_ CFH  
 Gas Line Size (in room) \_\_\_\_\_ In. NPT  
 Length of Gas Line \_\_\_\_\_ Eq Ft  
 Low Gas Pressure Setting \_\_\_\_\_ In. WC  
 High Gas Pressure Setting \_\_\_\_\_ In. WC  
 Gas Shut-Off Valve Type \_\_\_\_\_  
 (Ball, Lube cock)  
 Port \_\_\_\_\_ Std \_\_\_\_\_ Full

## VISUAL INSPECTION OF COMPONENTS

Verify inspection was done and condition of components are in good working order with a "yes"

Wiring Harness \_\_\_\_\_ Y/N  
 Burner (flame) \_\_\_\_\_ Y/N  
 Refractory (Visual) \_\_\_\_\_ Y/N  
 Remote flame sense \_\_\_\_\_ Y/N  
 Covers in place for outdoor \_\_\_\_\_ Y/N

## VENTING

Vent Size: \_\_\_\_\_ Stack Height: \_\_\_\_\_  
 Vent Material: \_\_\_\_\_ sketch vent on reverse side \*\*\*  
 Vent Termination Type: \_\_\_\_\_  
 Combustion Air Openings: Low \_\_\_\_\_ in<sup>2</sup>  
 Ventilation Air High \_\_\_\_\_ in<sup>2</sup>

## CLEARANCES

Front Clearance \_\_\_\_\_ In.  
 Right Side Clearance \_\_\_\_\_ In.  
 Left Side Clearance \_\_\_\_\_ In.  
 Rear Clearance \_\_\_\_\_ In.  
 Overhead Clearance \_\_\_\_\_ In.

## ELECTRICAL

Voltage Supply (VAC) \_\_\_\_\_ No Load \_\_\_\_\_  
 \_\_\_\_\_ Load \_\_\_\_\_  
 Voltage -24 VAC \_\_\_\_\_ VAC  
 Voltage Com to Ground \_\_\_\_\_ VAC  
 Hot Surface Igniter \_\_\_\_\_ Ohms  
 Auto High Limit Setting \_\_\_\_\_ deg F  
 Manual Reset High-Limit Setting \_\_\_\_\_ deg F  
 Operating Control Setting \_\_\_\_\_ deg F

Sketch plumbing on reverse side

## WATER SUPPLY

Flow Rate in GPM or Delta-T \_\_\_\_\_ If Avail  
 Measure flow rate at full fire  
 Pump Purge setting \_\_\_\_\_ Minutes  
 Low Water Cutoff \_\_\_\_\_ Test  
 Plumbing Size \_\_\_\_\_  
 Pump Size: \_\_\_\_\_ (Boiler) Pump HP: \_\_\_\_\_  
 Impeller trim \_\_\_\_\_ Pump Model \_\_\_\_\_  
 Louvers \_\_\_\_\_ Screens \_\_\_\_\_

## RAYMOTE (XFiire Optional)

Wi-Fi signal available in boiler room \_\_\_\_\_  
 Boiler provisioned with valid WiFi credentials \_\_\_\_\_  
 Wi-Fi signal strength (RSSI > -80) \_\_\_\_\_

## EMISSIONS SETTINGS AND TEST INFORMATION

(AT FULL FIRE) (AT MIN. FIRE)

Blower Suction Pressure \_\_\_\_\_ In. WC \_\_\_\_\_ In. WC  
 Supply Gas Pressure \_\_\_\_\_ In. WC \_\_\_\_\_ In. WC  
 Verify stable pressure static and dynamic condition

## Nominal Factory Recommended Settings

See manual or card tag  
 See manual or card tag

The following measurements must be obtained with a calibrated combustion analyzer.

|                 |           |           |                   |
|-----------------|-----------|-----------|-------------------|
| O <sub>2</sub>  | _____ %   | _____ %   | See manual        |
| CO              | _____ PPM | _____ PPM | Less than 100 PPM |
| CO <sub>2</sub> | _____ %   | _____ %   | See manual        |

Model Number: \_\_\_\_\_  
 \*\*\* Note: draw venting with details, such as extractors, barometric dampers, blast dampers or draft inducers

Serial Number: \_\_\_\_\_  
 Site Elevation Above Sea Level \_\_\_\_\_ Ft.

Job Name \_\_\_\_\_  
 Address \_\_\_\_\_  
 Physical Location of Boiler: Indoors \_\_\_\_\_; Outdoors \_\_\_\_\_; Ground Level \_\_\_\_\_; Roof \_\_\_\_\_; Below Grade \_\_\_\_\_  
 Mechanical Contractor / Installer \_\_\_\_\_  
 Date and Time of Start-up \_\_\_\_\_ Print Name and Signature of Start-up Technician \_\_\_\_\_

# 14. WARRANTY

APPROVED

Effective 03/26/21

## LIMITED WARRANTY

### XFIIRE

**TYPES: BOILERS AND WATER HEATERS**

**Models: 300B-1000B**

### IFIRE

**Models: IBGWSF1-0300 to -1000**

**IVGWSF1-0300 to -1000**

#### SCOPE

Rheem Manufacturing Co.(Rheem) and its subsidiaries Raypak Inc. (Raypak) and IBC Technologies Inc. (IBC) warrants to the original owner that all parts of this heater which are actually manufactured by Rheem will be free from defects in materials and workmanship under normal use and service for the specified warranty periods and subject to the conditions set forth in this Limited Warranty. Labor charges and other costs for parts removal or reinstallation, shipping and transportation are not covered by this Limited Warranty, but are the owner's responsibility.

#### EFFECTIVE DATE

The Effective Date of this Limited Warranty is the date of original installation if properly documented; if you are not able to provide documentary proof of the date of original installation, the Effective Date will be the date of manufacture plus 180 days.

#### HEAT EXCHANGER WARRANTY PERIODS

##### Space Heating (Closed Loop System)

Ten (10) year limited warranty from date of heater installation. This warranty applies only to boilers utilized in closed loop heating systems that have been properly installed based upon manufacturer's installation instructions.

| <u>Year of Claim</u>  | <u>0-5</u> | <u>6</u> | <u>7</u> | <u>8</u> | <u>9</u> |
|-----------------------|------------|----------|----------|----------|----------|
| Percentage to be paid |            |          |          |          |          |
| By purchaser          | 0%         | 20%      | 40%      | 60%      | 80%      |

##### Domestic Hot Water (Open Systems)

Five (5) year limited warranty from Effective Date.

##### Thermal Shock Warranty

Twenty (20) years from date of heater installation against "Thermal Shock" (excluded, however, if caused by heater operation at large changes exceeding 150°F between the water temperature at intake and heater temperature, or operating at heater temperatures exceeding 200°F).

#### **ANY OTHER PART MANUFACTURED BY Rheem**

One (1) year warranty from date of heater installation, or eighteen (18) months from date of factory shipment based on Rheem's records, whichever comes first.

SATISFACTORY PROOF OF INSTALLATION DATE, SUCH AS INSTALLER INVOICE, IS REQUIRED. THIS WARRANTY WILL BE VOID IF THE HEATER RATING PLATE IS ALTERED OR REMOVED.

#### ADDITIONAL WARRANTY EXCLUSIONS

This warranty does **NOT** cover failures or malfunctions resulting from:

1. Failure to properly install, operate or maintain the heater in accordance with our printed instructions provided.
2. Abuse, alteration, accident, fire, flood and the like.
3. Sediment or lime build-up, freezing, or other conditions causing inadequate water circulation.
4. High velocity flow exceeding heater design rates.
5. Failure of connected system devices, such as pump or controller.
6. Use of non-factory authorized accessories or other components in conjunction with the heater system.
7. Failing to eliminate air from, or replenish water in, the connected water system.
8. Chemical contamination of combustion air or use of chemical additives to water.

**UNCONTROLLED DOCUMENT IF PRINTED**



**APPROVED**

Effective 03/26/21

**REPAIR OR REPLACEMENT**

At its option, Rheem will repair or replace a defective part(s) in accordance with the terms of this Limited Warranty, if it fails in normal use and service during its specified warranty period. The failed part must first be returned to Rheem if requested, with transportation charges prepaid, and all applicable warranty conditions found satisfied. The repair or replacement part will be warranted for only the unexpired portion of the original Limited Warranty. Rheem makes no warranty whatsoever on parts not manufactured by it, but Rheem will apply any such warranty as may be provided to it by the parts manufacturer.

**HOW TO MAKE A WARRANTY CLAIM**

You should immediately notify the original installer, supplying the model number and serial numbers of the unit, date of installation and description of the problem. The installer must then contact their distributor for instructions regarding the claim. If either is not available, please contact:

For **Raypak**: Service Manager, Raypak Inc. 2151 Eastman Avenue, Oxnard CA 93030, or call (805) 278-5300

For **IBC USA**: Technical Support, IBC Technologies USA Inc., 121 Walter A. Gaines Way, Lawnside NJ 08045 or call (856) 887-0544 or toll-free phone 1-844-HEAT-IBC.

For **IBC Canada**: Technical Support, IBC Technologies Inc., 8015 North Fraser Way, Burnaby, BC V5J 5M8, or call (604) 877-0277 or toll-free phone 1-844-HEAT-IBC

In all cases, proper authorization must first be received before repair or replacement of any part.

**EXCLUSIVE WARRANTY-LIMITATION OF LIABILITY**

The Limited Warranty is the only warranty for this product and its component parts given by Rheem. No one is authorized to make any other warranties on Rheem's behalf. **ANY IMPLIED WARRANTIES, INCLUDING MERCHANTABILITY OR FITNESS FOR A PARTICULAR PURPOSE, SHALL NOT EXTEND BEYOND THE APPLICABLE WARRANTY PERIODS SPECIFIED IN THIS LIMITED WARRANTY. RHEEM'S SOLE LIABILITY WITH RESPECT TO ANY DEFECT SHALL BE AS SET FORTH IN THIS LIMITED WARRANTY. IT IS AGREED THAT RHEEM SHALL HAVE NO LIABILITY WHETHER UNDER THIS LIMITED WARRANTY OR IN CONTRACT, TORT OR NEGLIGENCE OR OTHERWISE FOR CLAIMS FOR SPECIAL, INCIDENTAL OR CONSEQUENTIAL DAMAGES (INCLUDING NO LIABILITY FOR DAMAGE FROM WATER LEAKAGE) WHICH ARE EXPRESSLY EXCLUDED, NOTWITHSTANDING ANY FAILURE OF ESSENTIAL PURPOSE OF ANY LIMITED REMEDY.** Some states do not allow limitations on how long an implied warranty lasts, or for the exclusion of incidental or consequential damages, so the above limitation or exclusion may not apply to you.

**THIS LIMITED WARRANTY GIVES YOU SPECIFIC LEGAL RIGHTS, AND YOU MAY ALSO HAVE OTHER RIGHTS WHICH VARY FROM STATE TO STATE.**

We suggest you immediately record the model and serial number and date of original installation and retain this Limited Warranty Certificate along with your original proof of purchase and date of installation/start-up in the event warranty service is needed.

**DO NOT RETURN THIS DOCUMENT TO RHEEM OR ITS SUBSIDIARIES. KEEP IT WITH YOUR HEATER OR BUSINESS RECORDS.**

|                      |                               |
|----------------------|-------------------------------|
| Name of Owner        | Name of Installer             |
| Owners Address       | Telephone Number of Installer |
| Date of Installation | Installation Site             |
| Model Number         | Serial Number                 |

