

APPROVED

INSTALLATION AND OPERATING INSTRUCTIONS



2 & 4-Stage Temperature Controllers

For Raytherm® & Hi Delta®
Boilers & Water Heaters



FOR YOUR SAFETY: Do not store or use gasoline or other flammable vapors and liquids or other combustible materials in the vicinity of this or any other appliance. To do so may result in an explosion or fire.

NOTE: The instructions in this manual are for the use of qualified individuals specially trained and experienced in the installation and maintenance of this type of equipment and related system components. Installation and service personnel are required by some states to be licensed. Persons not qualified shall not attempt to install, service, or maintain this equipment.

This manual should be maintained in legible condition and kept adjacent to the variable-speed pump or in a safe place for future use.



Effective: 03-25-22
Replaces: 10-11-10
P/N 241177 Rev. 6

APPROVED

Revision 6 reflects the following changes:

Reformatted and rearranged to current standards. Additional metric information added. Text added to Introduction on page 5. Section Max Outlet Temp and Lead Rotation added on page 6. Extensive text edits, both major and minor, made throughout for improved clarity and precision.

UNCONTROLLED DOCUMENT IF PRINTED

APPROVED
TABLE OF CONTENTS

1. WARNINGS	4	6. TROUBLESHOOTING	15
Pay Attention to these Terms	4	Connecting the Controller	16
2. INTRODUCTION	5	Testing the Controller's Outputs	16
3. USER INTERFACE	5	Sensor Resistance	16
Menu	5	7. ELECTRICAL WIRING TROUBLESHOOTING	17
DIP Switch Settings.....	6	8. WIRING CONNECTIONS.....	18
Max Outlet Temp and Lead Rotation.....	6	9. CONTROLLER SETTINGS	20
Item	6	View Menu (Mode 2)	20
Adjust.....	6	Adjust Menu (Mode 2).....	21
Display	6	View Menu (Mode 3).....	23
4. SEQUENCE OF OPERATION.....	6	Adjust Menu (Mode 3).....	24
General	6	View Menu (Mode 5).....	26
Powering up the Controller.....	6	Adjust Menu (Mode 5).....	27
Display Backlight.....	6	View Menu (Mode 7).....	30
Modes of Operation (Mode)	7	Adjust Menu (Mode 7).....	31
Code Descriptions	9	View Menu (Mode 8).....	33
Domestic Hot Water Override, modes 2, 5, and 7 (BOIL TARGET 2)	11	Adjust Menu (Mode 8).....	33
5. INSTALLATION.....	15	Error Messages (All Modes).....	34
Electrical Connections to the Controller.....	15	10. TECHNICAL DATA	35
Powered Input Connections	15	11. QUICK START SET-UP & PROGRAMMING TIPS.....	35
Sensor and Unpowered Input Connections	15		

1. WARNINGS

Pay Attention to these Terms

▲ DANGER	Indicates the presence of immediate hazards which will cause severe personal injury, death or substantial property damage if ignored.
▲ WARNING	Indicates the presence of hazards or unsafe practices which could cause severe personal injury, death or substantial property damage if ignored.
▲ CAUTION	Indicates the presence of hazards or unsafe practices which could cause minor personal injury or product or property damage if ignored.
CAUTION	CAUTION used without the warning alert symbol indicates a potentially hazardous condition which could cause minor personal injury or product or property damage if ignored.
NOTE	Indicates special instructions on installation, operation, or maintenance which are important but not related to personal injury hazards.

This manual, as well as the pool/spa heat pump pool heater itself, contains ANSI-approved product safety signs and labels. Please read these signs and labels, as they convey important safety information about hazards that may be potentially present in and around the heat pump pool heater.

2. INTRODUCTION

NOTE: Minimum 18 AWG, 105°C, stranded wire must be used for all low voltage (less than 30 volts) external connections to the unit. Solid conductors should not be used because they can cause excessive tension on contact points. Install conduit as appropriate. All high voltage wires must be the same size (105°C, stranded wire) as the ones on the unit or larger.

The Temp-Tracker 2-stage and 4-stage temperature controllers (Controller) are designed for use with heaters with two or four stages of operation in order to provide accurate water temperature control in a variety of applications. See **Table A** for available configurations. They can also provide sequencing with lead/lag on two boilers. See **Figure 4** and **Table B**. The Controllers may be used to provide a setpoint temperature, outdoor reset with reset override, or dedicated domestic hot water (DHW) generation and several options for external heater control. An additional relay contact is included with the “shipped loose” version to provide an alarm signal in case of a sensor failure.

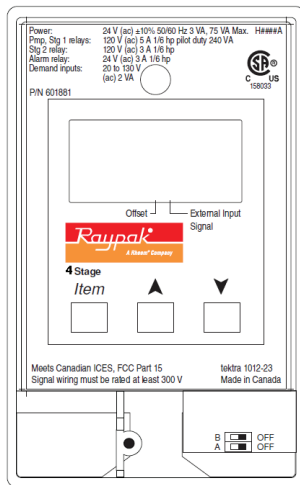


Figure 1. Temp-Tracker Controller

Item	P/N	Description
B-21	011573	4-stage, setpoint 70F°-225°F (21°C-107°C)
B-23	011574	4-stage with outdoor reset
B-26	011575	2-stage, setpoint 70F°-225°F (21°C-107°C)
B-27	011576	2-stage with outdoor reset

Table A. Available Configurations

Adding the outdoor sensor to a B-21 or B-26 will enable the outdoor reset function.

When shipped loose, this package includes:

- (1) Controller in enclosure
- (3) Water sensors
- (1) Outdoor air sensor
- (1) Well Assembly



Figure 2. Temp-Tracker Controller Kit (shipped loose)

3. USER INTERFACE

The Controller uses a Liquid Crystal Display (LCD) as a method of supplying information. Use the LCD to setup and monitor the operation of your system. The Controller uses three push buttons (Item, ▲, ▼) for selecting and adjusting the settings (see **Figure 3**). As you program your Controller, record your settings in the actual settings columns of the Adjust menu in **Table I**.



Figure 3. Controller Push Buttons

Menu

All of the items displayed by the Controller are organized into two menus. These menus are listed on the upper right-hand side of the display (Menu Field). The default menu for Controller is the View menu. While in the View menu, the View segment is displayed. To select the Adjust menu, press and hold all three buttons simultaneously for one second (see **Figure 3**). The display then advances to the Adjust menu and the Adjust segment is turned on in the display. The display will automatically revert back to the View menu after 20 seconds of keypad inactivity. Once in a menu, there will be a group of items that can be viewed within that menu.

DIP Switch Settings

(DIP package located under cover on front of PCB)

Switch	Function	Position	
		ON	OFF (Factory)
Two-Stage			
A	Heater Outlet Max	200°F (93°C)	235°F (113°C)
B	Heater Plant	(2) On/Off units	(1) 2-Stage unit
Four-Stage			
A	Heater Outlet Max	200°F (93°C)	235°F (113°C)
B	Heater Plant	(2) 2-Stage units	(1) 4-Stage unit

Table B. DIP Switch Settings



Figure 4. DIP Switches (Default shown)

Max Outlet Temp and Lead Rotation

See **Figure 4** and **Table B**. DIP switch A controls the maximum allowable outlet temperature. DIP switch B controls the lead rotation function. If DIP switch B is turned OFF, the controller is set to control a single boiler with maximum stages. If DIP switch B is turned ON, the controller is set to control a pair of boilers. The lead boiler will automatically rotate after each 12-hours of runtime; this timing is fixed.

Item

The abbreviated name of the selected item will be displayed in the item field of the display. To view the next available item in a menu, press and release the Item button. The display will return to the first item in the selected menu (see **Figure 5**).

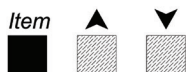


Figure 5. Item Button

Adjust

To make an adjustment to a setting in the Controller, begin by selecting the Adjust menu by pressing and holding simultaneously all three buttons for one second, and then selecting the desired item using the Item button. Finally, use the ▲ or ▼ button to make the adjustment (see **Figure 6**).

Additional information can be gained by observing the Status field of the LCD. The status field will indicate which of the Controller's outputs are currently active. Most

APPROVED

symbols in the status are only visible when the View menu is selected.



Figure 6. Adjust Buttons

Display

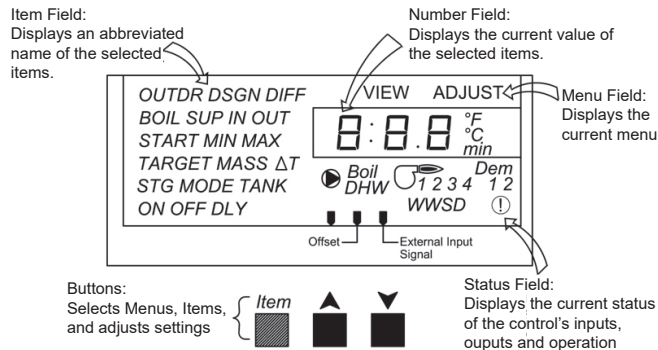


Figure 7. Display

	Pump: displays when the boiler pump is in operation	°F °C	°F, °C: Units of measurement
	Burner: displays when the stage 1 and/or 2, 3, 4 relay is turned on		Pointer: Displays the operation as indicated by the text

Figure 8. Symbol Description

4. SEQUENCE OF OPERATION

General

Powering up the Controller

When the Controller is powered up, it turns on all segments in the display for two seconds. Next, the software version is displayed for two seconds. Finally, the Controller enters into the normal operating mode.

Display Backlight

The control's display has a backlight that is permanently on while the control is powered.

Primary/Secondary Piping

In primary/secondary applications, the heater outlet temperature is typically higher than the system loop temperature. Therefore, the Controller uses an additional sensor (called the system sensor) to measure the temperature in the system. The operating sensor in primary / secondary piping applications is the system sensor. See **Figure 9**.

Modes of Operation (Mode)

NOTE: Mode of operation **MUST** be programmed into the Controller. See Figure 21 through Figure 25 on the following pages.

The Controller allows for eight modes of operation in order to define the Controller operation and piping arrangement used. The piping arrangement can be categorized into primary or primary/secondary. The mode of operation is selected using the MODE item in the adjust menu. The operating sensor measures the temperature being controlled out to the heating system.

The piping arrangement determines which sensor the Controller uses as the operating sensor. The operating sensor is either the heater outlet sensor or the system sensor.

It is up to the designer to determine the necessary components for and the configuration of the particular system being designed, including additional equipment, isolation relays (for loads greater than the Controller's specified output rating), and any safety devices which in the judgment of the designer are appropriate, in order to properly size, configure and design that system and to ensure compliance with building and safety code requirements.

Typically, Raypak recommends Mode 2 for primary/secondary hydronics, Mode 3 for domestic hot water and Mode 5 for primary/secondary hydronics using outdoor reset.

NOTE: The illustrations for each mode are only mechanical concept drawings; they are not intended to describe a complete system, nor any particular system. Consult the factory for piping arrangements not depicted here.

Two Setpoints Operation, Primary Piping Mode 1 (MODE = 1) (Not Supported)

Mode 1 is designed for setpoint operation using Primary Piping. Once a Call-for-heat (CFH) is present, the control stages the heater to maintain the heater target 1 at the heater outlet sensor. Once an indirect DHW override is present, the control stages the heater to maintain the heater target 2 at the heater outlet sensor. If both demands are present at the same time, the control operates at the higher of the two targets.

Two Setpoints with Primary/Secondary Piping Mode 2 (Mode = 2)

Mode 2 is designed for setpoint operation using Primary/Secondary piping (see Figure 9). A CFH is available to activate a setpoint for space heating. An indirect DHW override is available to activate a second setpoint for heating an indirect domestic hot water tank.

Once a CFH is present, the control stages the heater to maintain the heater target 1 at the heater supply sensor.

Once an indirect DHW override is present, the control stages the heater to maintain the heater target 2 at the heater system sensor. If both demands are present, the control operates at the higher of the two targets.

Mode 2 requires the use of three water sensors. The inlet water sensor is located in the inlet side of the in/out header. The outlet sensor is located in the outlet side of the in/out header. The system sensor (terminals 6 and 4) must be located as shown in Figure 9.

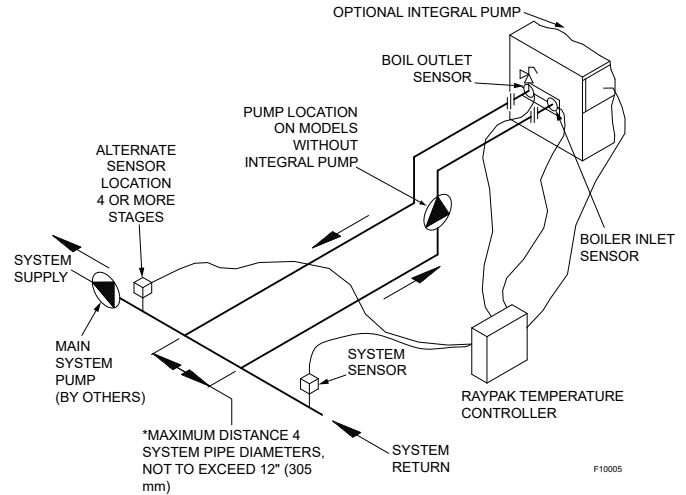


Figure 9. Primary/Secondary Piping (Mode 2)

Domestic Hot Water Operation, Uni-Temp 80 Piping (Mode 3)

Mode 3 is designed for dedicated DHW operation using Uni-Temp 80 piping. The Controller operates the heater to maintain a tank temperature at the system sensor.

Mode 3 requires the use of three water sensors. The inlet water sensor is located in the inlet side of the in/out header and the outlet sensor is located in the outlet side of the in/out header. The system sensor (terminals 6 and 4) must be located in the storage tank, as shown in Figure 10.

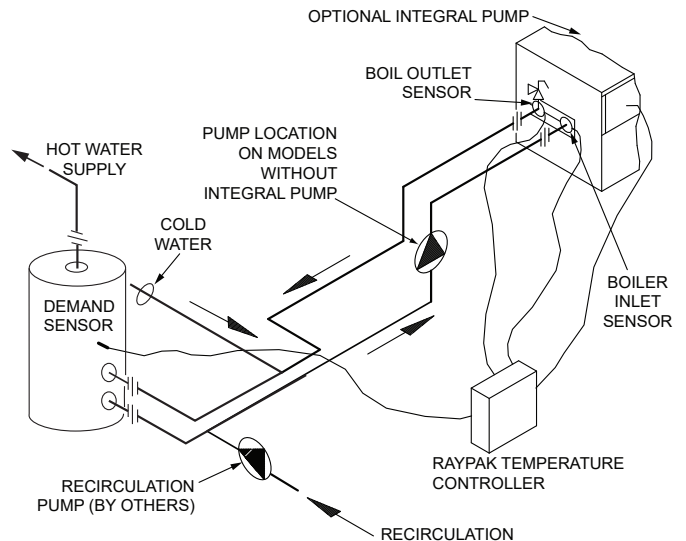


Figure 10. Uni-Temp 80 Piping (Mode 3)

APPROVED

Outdoor Reset and Override Operation with Primary Piping Mode 4 (Mode = 4) (Not Supported)

Mode 4 is designed for outdoor reset and override operation using Primary Piping. Once a CFH is present, the control stages the heater to maintain the calculated outdoor reset target at the heater outlet sensor. Once an indirect DWH override is present, the control stages the heater to maintain the heater target 2 at the heater outlet sensor. If both demands are present at the same time, the control operates at the higher of the two targets.

Outdoor Reset and Override Operation with Primary/Secondary Piping Mode 5 (Mode = 5)

Mode 5 is designed for outdoor reset and override operation using Primary /Secondary Piping. The CFH is available to provide outdoor reset for hydronic heating systems. The override can be used to heat an indirect domestic hot water tank.

Once a CFH is present, the control stages the heater to maintain the calculated outdoor reset target at the heater system sensor. Once an indirect DHW override is present, the control stages the heater to maintain the heater target 2 at the heater system sensor. If both demands are present at the same time, the control operates at the higher of the two targets.

Mode 5 requires the use of three water sensors and one air sensor. The inlet water sensor is located in the inlet side of the in/out header. The outlet sensor is located in the outlet side of the in/out header. The system sensor (terminals 6 and 4) must be located on the system supply pipe, as shown in **Figure 11**.

The outdoor air sensor must be located on the coldest side of the building in a shaded area out of direct sunlight.

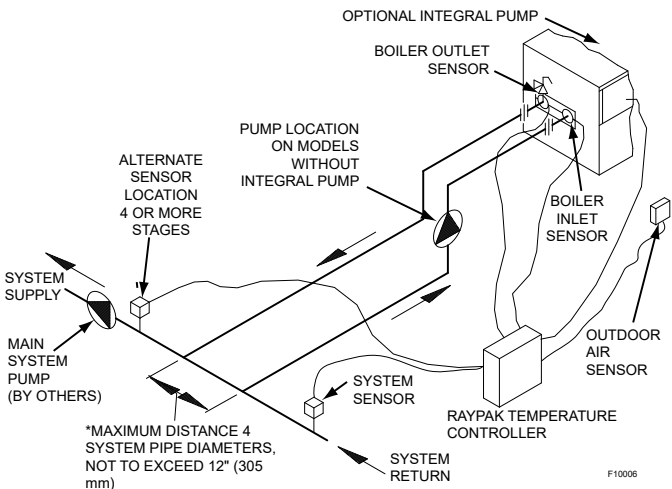


Figure 11. Primary/Secondary Piping with Outdoor Reset (Mode 5)

External Target Temperature Input and Override with Primary Piping Mode 6 (Mode = 6) (Not Supported)

Mode 6 is designed for a 0-10VDC or a 4-20 mA external input signal and override operation using Primary Piping. The external input signal creates an internal CFH and changes the heater target according to a linear scale. The control stages the heater to maintain the heater target at the heater outlet sensor.

External Target Temperature Input and Override with Primary/Secondary Piping Mode 7 (Mode = 7)

Mode 7 is designed for operation driven by an external 0-10VDC input signal and override operation using Primary/Secondary Piping. The external signal can be provided from a Building Management System. The override can be used to heat an indirect domestic hot water tank.

The external signal creates an internal CFH and changes the heater target according to a linear scale. The control stages the heater to maintain the heater target at the heater system sensor.

Once an indirect DHW override is present, the control stages the heater to maintain the heater target at the heater system sensor. If both an external input signal and an indirect DHW override are present at the same time, the control operates at the higher of the two targets.

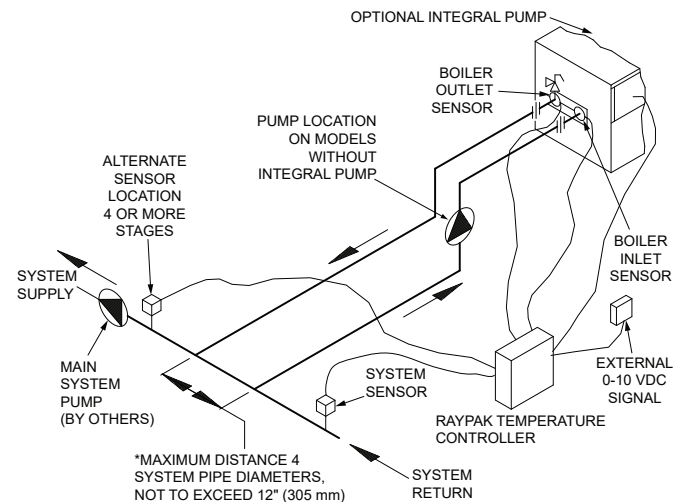


Figure 12. External Input Target Temperature and Setpoint Operation, Primary-Secondary Piping (Mode 7)

NOTE: To convert a 0-20 mA input signal to 0-10 VDC, a 500 Ω resistor must be added. See Figure 13.

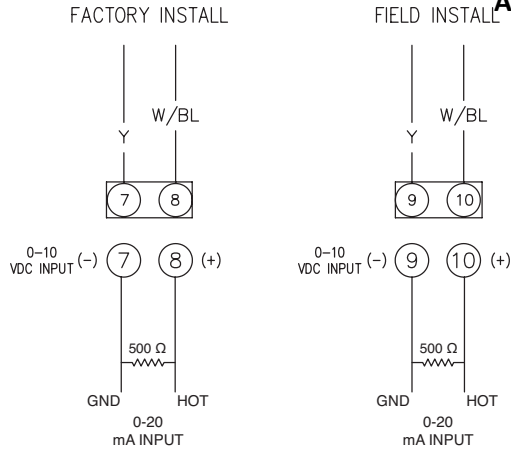


Figure 13. 500 Ω Resistor for 4-20 mA Operation

External Direct Drive Operation Mode 8 (Mode = 8)

Mode 8 is designed for operation driven by an external 0-10VDC or a 4-20 mA input signal from a building management system or external sequencer, such as the Raypak Temp-Tracker Mod+ Hybrid, to drive the staging rate directly with either Primary or Primary/Secondary piping. The indirect DHW override is disabled.

The control receives a CFH and analog signal provided from an external control. The control stages the heater according to the input signal.

The maximum outlet temperature is controlled by DIP switch “A.”

Fixed Heater Outlet Maximum:

200°F (93°C) (“A” = “ON”)

235°F (113°C) (“A” = “OFF”)

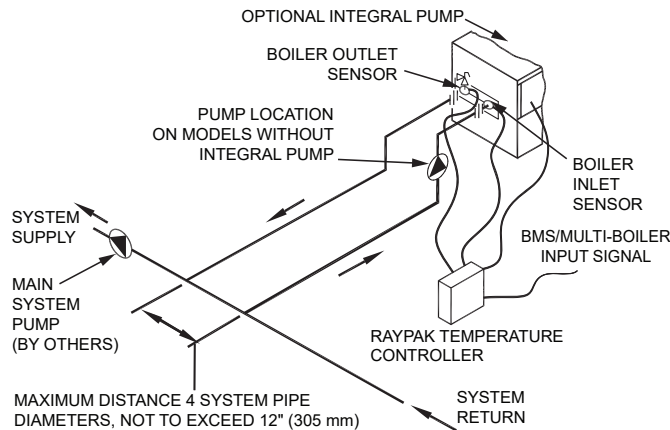


Figure 14. External Direct Drive Operation (Mode 8)

Code Descriptions

Heater Differential (DIFF)

A heat source must be operated with a differential in order to prevent short-cycling. The heater differential is divided around the heater target temperature. The first-stage contact will close when the water temperature at

the operating sensor is 1/2 of the differential setting below the heater target temperature, and will open when the water temperature at the operating sensor is 1/2 of the differential setting above the heater target temperature. The remaining stages will operate sequentially based on the staging mode selected.

Manual Differential

The differential can be manually set to a specific value in the ADJUST menu. The available range is 2°F (1°C) minimum, 42°F (23°C) maximum.

Fixed Differential

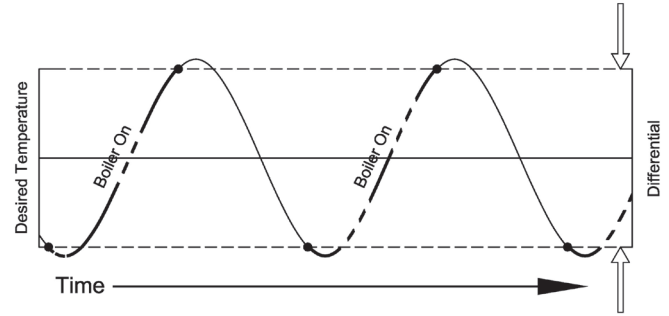


Figure 15. Manual Differential

Auto Differential

This function is only available when STGMODE is set to PID.

If Auto Differential is selected, the control automatically determines the best differential as the load changes, thereby improving efficiency. During light loads, the differential is increased to allow longer on and off times to reduce the potential for short-cycling. During large loads, the differential is narrowed, thereby improving comfort in heating spaces by reducing temperature swing.

Automatic Differential

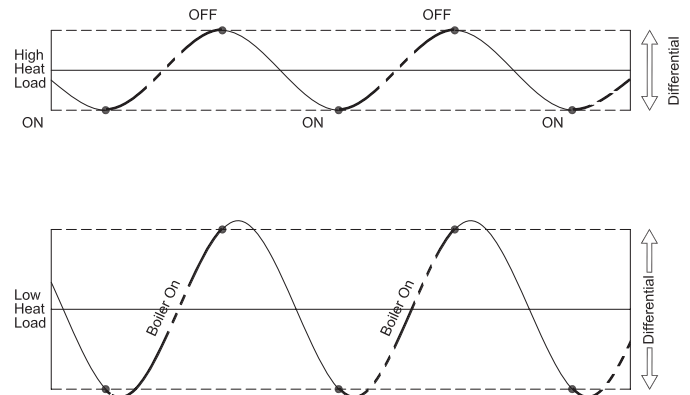


Figure 16. Auto Differential

Staging Mode (STGMODE)

The Controller can operate up to its maximum number of stages in order to supply the required target temperature. The method of staging used by the Controller is either P (proportional) or PID (proportional, integral & derivative), and is selected in the ADJUST menu.

Proportional (P)

Proportional staging is based on manually-adjusted settings that determine when the next stage is required to turn on. These manual settings are based on temperature and time. The interstage differential sets the temperature drop at which the next stage turns on. However, in order for a stage to fire, both the “interstage delay on” and “minimum off” times must first elapse.

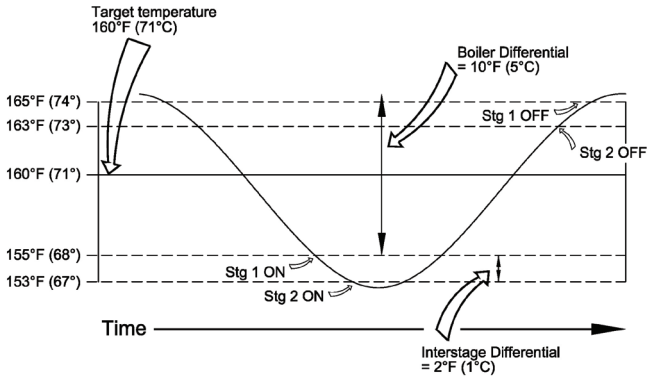


Figure 17. Proportional Staging

Proportional, Integral & Derivative (PID)

PID staging allows the Controller to determine when the next stage is required to turn on or off. The Controller automatically determines the settings that are manually selected in the proportional mode.

After each stage is turned on in the firing sequence, the Controller waits a minimum amount of time before turning on the next stage. After the minimum time delay between stages has passed, the Controller examines the control error to determine when the next stage is to fire. The control error is determined using PID logic.

Proportional compares the actual operating sensor temperature to the heater target temperature. The colder the temperature, the sooner the next stage is turned on.

Integral compares the operating sensor temperature offset (error) to the heater target temperature over a period of time.

Derivative determines how fast or slow the operating sensor temperature is changing. If the temperature is increasing slowly, the next stage is turned sooner. If the temperature is increasing quickly, the next stage is turned on later, if at all.

Interstage Differential (STG DIFF)

The “interstage differential” is the temperature drop at which the next stage will turn on. Once a stage turns on, the next stage cannot turn on until the temperature drops the “interstage differential” below the temperature at which the previous stage turned on. This variable is found in the ADJUST menu.

Interstage Delay On (ON DLY)

The “interstage delay on” is the amount of time that must elapse before turning on the next stage. Once a stage turns on, the next stage cannot turn on until the interstage delay on time elapses. This variable defaults to 1 minute. The minimum setting is 10 seconds; the maximum setting is 8 minutes. This value is found in the ADJUST menu. This setting is only available when STG MODE is set to P.

Interstage Delay Off (OFF DLY)

The “interstage delay off” is the amount of time that must elapse before turning off the next stage. Once a stage turns off, the next stage cannot turn off until the interstage delay off time elapses. This variable defaults to 30 seconds. The minimum setting is 10 seconds; the maximum setting is 4 minutes. This value is found in the ADJUST menu. This setting is only available when STG MODE is set to P.

Minimum On Time (MIN ON)

The “minimum on” time is the minimum amount of time that a stage must be on before it is allowed to turn off. Once a stage turns on, it cannot turn off until minimum on time elapses. This variable defaults to 30 seconds. The minimum setting is 10 seconds; the maximum setting is 5 minutes. It is adjustable in the ADJUST menu. This setting is only available when STG MODE is set to P.

Minimum Off Time (MIN OFF)

The “minimum off” time is the minimum amount of time that a stage must be off before it is allowed to turn on. Once a stage turns off, it cannot turn on until the minimum off time elapses. This variable defaults to 50 seconds. The minimum setting is 10 seconds; the maximum setting is 5 minutes. This value is found in the ADJUST menu. This setting is only available when STG MODE is set to P.

Heater Mass (BOIL MASS)

The heater mass setting (1, 2 or 3) allows the installer to adjust the Controller to the thermal mass of different types of heat sources used. The heater mass setting automatically determines the interstage differential, interstage delay on, interstage delay off, minimum on time and minimum off time of the stages when PID staging is used. A higher thermal mass setting provides slower staging, while a lower thermal mass provides faster staging. See **Table C**.

Setting	Definition
Mass 1	Low Volume, high Recovery (default)
Mass 2	Medium Volume, Medium Recovery
Mass 3	High Volume Low Recovery

Table C. Heater Mass Definitions

NOTE: Always use a heater mass setting of 1 for Raypak equipment. If the Controller continues to stage too rapidly, contact Raypak.

APPROVED

Heater Minimum (BOIL MIN)

This is the lowest water temperature that the Controller is allowed to use as a heater target temperature (e.g. 120°F). During mild conditions, if the Controller calculates a heater target temperature that is below the BOIL MIN setting, the heater target temperature is adjusted to at least the BOIL MIN setting.

During this condition, if the heater is operating, the MIN segment turns on in the LCD while the heater target temperature or heater operating sensor temperature is viewed.

The minimum setting is 80°F (27°C); the maximum setting is 180°F (82°C). The default setting is 125°F (52°C). This value is found in the ADJUST menu.

Additional plumbing and/or controls may be required to maintain the heater at or above its minimum inlet temperature.

NOTE: If the installed heater is designed to operate at a target temperature less than 80°F (27°C), set the BOIL MIN adjustments to OFF.

Heater Maximum (BOIL MAX)

This is the highest water temperature that the Controller is allowed to use as a heater target temperature. If the Controller does target BOIL MAX, and the heater outlet sensor is near the BOIL MAX temperature, the MAX segment turns on in the LCD while the heater target, heater inlet, heater outlet or heater supply temperature is viewed.

The minimum setting is 120°F (49°C); the maximum setting is 230°F (110°C), with a default setting of 200°F (93°C). This value is found in the ADJUST menu.

Heater Target Temperature (BOIL TARGET)

The heater target temperature is determined from the mode of operation and type of demand applied. The Controller displays the temperature that it is currently trying to maintain at the operating sensor as BOIL TARGET in the VIEW menu.

The operating sensor for modes 2, 3, 5 and 7 is the system sensor. If the Controller is not presently enabled for heat, it displays "--" in the LCD. In Mode 8, no heater target temperature is generated.

System Pump Operation

The pump contacts operate when:

- A CFH is present based on the tank sensor for dedicated DHW operation (Mode 3).
- While the heater is firing and Primary/Secondary piping (Mode 2, 5, or 7) is used. Primary/ Secondary piping reduces standby losses by isolating the heater from the system while the heater is off.
- During external direct drive operation (Mode 8), the

pump contact closes whenever there is an internal CFH.

- After the system shuts off, the pump remains on for a few minutes to purge heat from the heater to the system.

System Pump Purge (DLY)

The controller operates the system pump based on the Pump DLY setting. Once the system shuts down, the controller keeps the system pump running for the time selected.

Available values:

- **Pump DLY OFF** No purging, system pump shuts down when the system shuts down.
- **Pump DLY (number)** Minimum setting 20 seconds; maximum setting 9 minutes 55 seconds (9:55), default setting 20 seconds.
- **Pump DLY ON** System pump runs continuously. When ON is selected and the control is configured for outdoor reset, the system pump continues to run even during Warm Weather Shut Down (Mode 5).

Pump Exercising

If the system pump has not operated at least once every 70 hours, the control automatically turns on the output for 10 seconds. This minimizes the possibility of the pump seizing during a long period of inactivity. This is not a variable, and the 70-hr setting is fixed.

Setpoint Operation (BOIL TARGET)

A setpoint is a fixed water temperature target that the heater is to maintain at the system sensor. The heater maintains the heater target by operating the stages using the proportional or the PID logic together with the heater differential. The setpoint temperature is the BOIL TARGET variable, and is found in the ADJUST menu.

Enable/disable, Mode 2 (BOIL TARGET 1)

A call-for-heat (CFH) must be generated whenever heat is required for the primary heating load. This is achieved when 24VAC is applied across the enable/disable connection (terminals 1 and 2 on the terminal block). Once the voltage is applied, the control energizes wire connection Dem 1, activates the Dem 1 segment in the display, and the controller operates the heater stages as needed to maintain the given value, measured at the system sensor.

Domestic Hot Water Override, modes 2, 5, and 7 (BOIL TARGET 2)

A CFH must be generated whenever heat is required for the secondary heating load, such as an indirect domestic hot water tank. This is achieved when 24VAC is applied across the DHW contacts (terminals 1 and 3 on the terminal block). Once the voltage is applied, the control energizes

wire connection Dem 2, activates the Dem 2 segment in the display, and the controller operates the heater stages as needed to maintain the given value, measured as value, measured at the system sensor.

Dedicated Domestic Hot Water (DHW) Operation (MODE 3)

When mode 3 is selected, the Controller provides dedicated DHW operation.

⚠ WARNING: Verify closure across the Enable/Disable contacts terminals 1 and 2 on the terminal block. DO NOT use DHW override on terminal 3.

Internal DHW Demand

A sensor is required to be installed in the tank and connected to the Com and the Sys/D terminals (6 and 4). A CFH for DHW is generated when the temperature at the DHW sensor drops 1/2 of the tank differential setting below the desired DHW tank temperature. The TANK TARGET setting is used to set the desired DHW tank temperature. Once a CFH is generated, the Dem segment turns on in the LCD.

The Controller then operates the heater stages to maintain the programmed tank target temperature (TANK TARGET) at the heater system sensor located in the tank. This variable has a minimum setting of 35°F (2°C), a maximum setting of 266°F (130°C), and a default setting of 120°F (49°C). If set to OFF, the unit is disabled. This value is found in the ADJUST menu. This variable is only available in MODE 3.

Tank Differential (TANK DIFF)

A differential setting that operates 1/2 above and 1/2 below the TANK TARGET. This is only available in MODE 3, and is selectable in the ADJUST menu.

Outdoor Reset Operation (MODE 5)

When Mode 5 is selected, the Controller uses outdoor reset to control the water temperature. Outdoor reset adjusts the target temperature based on the outdoor air temperature and the reset ratio; as the outdoor air temperature rises, the need for heat drops and the setpoint is reduced. The reset ratio is determined from the Heater Start, Heater Design, Outdoor Start and Outdoor Design settings.

Enable/Disable

A CFH is generated when a voltage of 24 VAC is applied across the Enable/Disable terminals (1 and 2). Once voltage is applied, the Controller turns on the Dem 1 segment in the display. If the Controller is not in Warm Weather Shut Down (WWSD), it then operates the heater stages to maintain the heater target temperature.

NOTE: If the controller is in WWSD, the WWSD segment is shown in the display and the heater target in the view menu of the display remains " - - - " (no target).

APPROVED

Reset Ratio

The controller uses the following four settings to calculate the Reset Ratio (RR):

$$\text{RESET RATIO (RR)} = \frac{\text{BOILER DESIGN} - \text{BOILER START}}{\text{OUTDOOR START} - \text{OUTDOOR DESIGN}}$$

For example, using the Mode 5 default values, the RR would be .56:1.

Heater Start (BOIL START)

The BOIL START temperature is the theoretical supply water temperature that the system requires when the outdoor air temperature equals the OUTDR START temperature setting. The BOIL START is typically set to the desired building temperature.

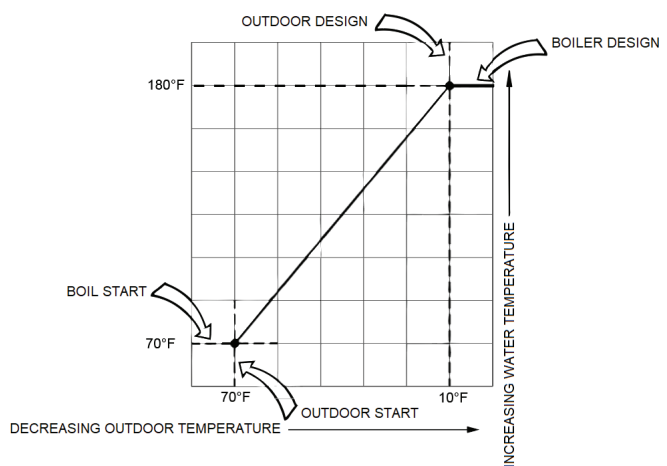


Figure 18. Heater Start

Outdoor Start (OUTDR START)

The OUTDR START temperature is the outdoor air temperature at which the Controller provides the BOIL START water temperature to the system. The OUTDR START is typically set to the desired building temperature.

Outdoor Design (OUTDR DSGN)

The OUTDR DSGN is the outdoor air temperature that is the typical coldest temperature of the year where the building is located. This temperature is used when doing heat loss calculations for the building.

Heater Design (BOIL DSGN)

The BOIL DSGN is the water temperature required to heat the zones when the outdoor air is as cold as the OUTDR DSGN temperature.

Warm Weather Shut Down (WWSD)

When the outdoor air temperature rises above the WWSD setting, the Controller turns on the WWSD segment in the display. When the Controller is in Warm Weather Shut

Down, the Dem 1 segment is displayed if there is a heat demand. However, the Controller does not operate the heating system to satisfy this demand.

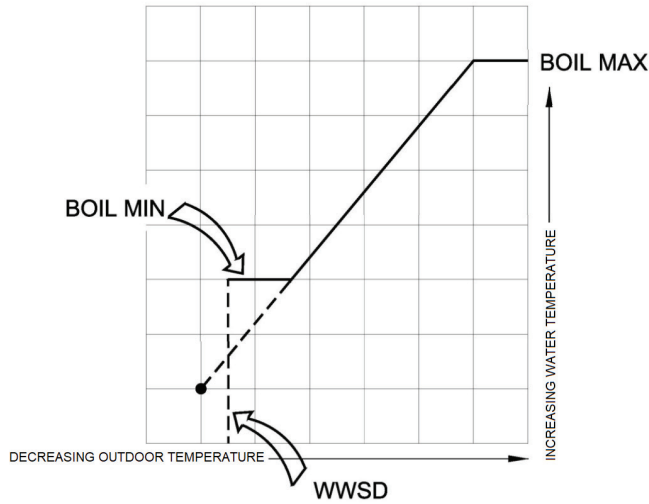


Figure 19. Warm Weather Shutdown

External Temperature Target Input

When Mode 7 is selected, the controller allows an external control to operate the heater temperature through an input signal generated by a Building Management System (BMS) or Energy Management System (EMS).

CFH

A CFH is generated when a contact closure is present at the enable/disable connection on pins 1 and 2 of the terminal block (or pins 1 and 3 for Indirect DHW), and an analog positive 0-10 VDC signal is applied to the +V (in) input (terminal 10). The negative V (DC) is applied to the Com/- input (terminal 9).

0-10 VDC or 0-20mA External Input (Mode 7)

When the 0-10VDC range is selected, an input voltage of 1VDC corresponds to a heater target temperature of 50°F (10°C). An input voltage of 10VDC corresponds to a heater target temperature of 210°F (99°C). See **Table D**. As the voltage varies linearly between 1VDC and 10 VDC, the heater target temperature varies linearly between 50°F (10°C) and 210°F (99°C). If a voltage below 0.5VDC is received, the heater target temperature is displayed as " - - - " to indicate that there is no longer an internal CFH.

A 0-20 mA signal can be converted to a 0-10VDC signal by installing a 500 Ohm resistor in parallel to the input signal on the controller's terminals (terminals 9 & 10). See **Figure 13 on page 9**.

0-10 VDC	0-20 mA*	Heater Target
0	0	- - - (OFF)
1	2	50°F (10°C)
2	4	68°F (20°C)
3	6	86°F (30°C)
4	8	103°F (39°C)
5	10	121°F (49°C)
6	12	139°F (59°C)
7	14	157°F (69°C)
8	16	174°F (79°C)
9	18	192°F (89°C)
10	20	210°F (99°C)

*Requires a 500 Ω resistor

Table D. 0-10 VDC or 0-20mA External Input (Mode 7)

2-10 VDC or 4-20 mA External Input Signal

The external input signal can be selected to be either 0-10 VDC or 2-10 VDC. When the 2-10 VDC range is selected, an input of 2 VDC corresponds to a heater target temperature of 50°F (10°C). An input voltage of 10 VDC corresponds to a heater target temperature of 210° (99°C). See **Table E**. As the voltage varies between 2 VDC and 10 VDC, the heater target temperature varies linearly between 50°F (10°C) and 210°F (99°C). If a voltage below 1.5 VDC is received the heater target temperature is displayed as " - - - " to indicate that there is no longer an internal CFH.

A 4-20 mA signal can be converted to a 2-10 VDC signal by installing a 500 ohm resistor in parallel to the input signal on the controller's terminals (terminals 9 & 10).

2-10 VDC	4-20 mA*	Heater Target
0	0	- - - (OFF)
1	2	- - - (OFF)
2	4	50°F (10°C)
3	6	70°F (21°C)
4	8	90°F (32°C)
5	10	110°F (43°C)
6	12	130°F (54°C)
7	14	150°F (66°C)
8	16	170°F (77°C)
9	18	190°F (88°C)
10	20	210°F (99°C)

*Requires a 500 Ω resistor

Table E. 2-10 VDC or 4-20mA External Input (Mode 7)

APPROVED

Offset

The offset setting allow the heater target temperature to be fine tuned to the external input signal. The controller reads the external input signal and converts this to a heater target temperature. The offset is then added to the heater target temperature.

Example	Range = 0-10 VDC	
	Input = 7 VDC	157°F (69°C)
	Offset = + 5°F (3°C)	+ 5°F (3°C)
	Heater Target =	162°F (72°C)

External Direct Drive Operation (Mode 8)

When Mode 8 is selected, the controller allows an external control to operate the heater through an analog direct drive input signal provided by a heater sequencing control, such as the Raypak Temp-Tracker Mod+ Hybrid. When in mode 8, the indirect DHW override is disabled.

Direct Drive Input Signal

An external heater sequencer provides a positive 0-10 VDC input signal to the controller +V input (terminal 10). The negative VDC signal is applied to the Com/- input (terminal 9).

The heater remains off while the direct drive input signal is between 0.0 to 0.5 VDC. The Stage 1 contact remains on as long as the direct drive input signal reaches or exceeds 0.5 VDC. The Stage 2 contact is activated once the direct drive input signal reaches or exceeds 3.0 VDC. The Stage 3 contact is activated once the direct drive input signal reaches or exceeds 5.5 VDC. The Stage 4 contact is activated once the direct drive input signal reaches or exceeds 8.0 VDC.

Pump Operation

The pump is turned on as soon as the direct drive input signal reaches 0.5 VDC. Once the direct drive input signal falls below 0.5 VDC, the pump continues to operate until the Pump DLY purge expires, then the pump shuts off.

Boiler Outlet Maximum Temperature

The external sequencer operates the heater plant to maintain the BOIL TARGET setting. However, the BOIL OUT MAX setting limits the highest temperature at the heater outlet sensor. Should the heater outlet setting exceed the BOIL OUT MAX setting, the stage contacts are opened to shut off the heater. The heater remains off for the minimum off time and the heater outlet temperature falls 2°F (1°C) below the BOIL OUT MAX setting.

NOTE: BOILER OUT MAX is set using DIP Switch "A" (see Figure 4).

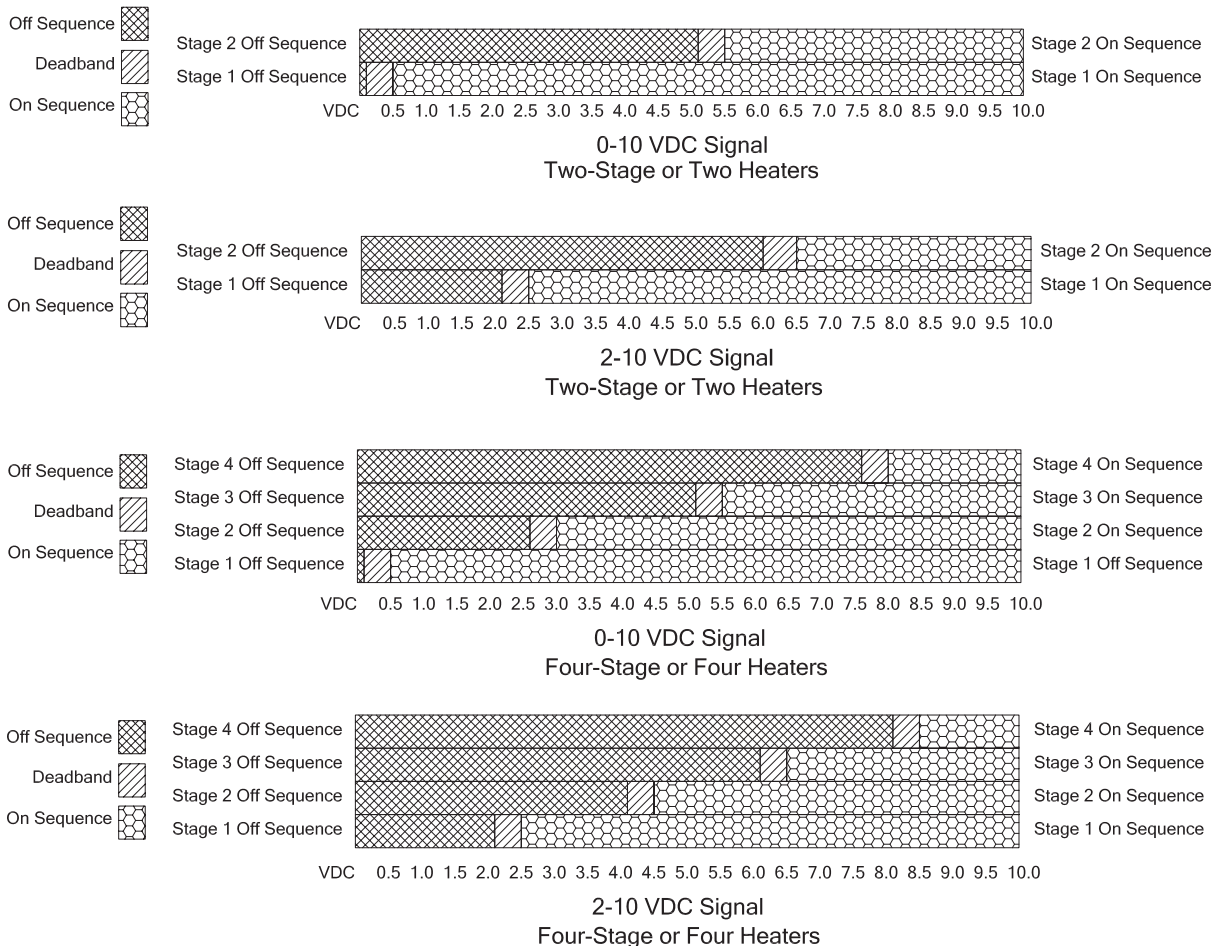


Figure 20. Stage Actuation and Dead Bands
UNCONTROLLED DOCUMENT IF PRINTED

5. INSTALLATION

The following describes field-installation:

For field-installation, this controller is shipped inside a water-resistant enclosure for wall mounting. This kit includes a built-in transformer, an alarm relay, and three terminal blocks (labeled P1, P2 and P3) with built-in decals describing the various connections. See **Figure 25** for proper wiring.

CAUTION: The 120VAC connection must be applied to Terminal Block P3 (pins 1 and 2). Pin 3 must be connected to Ground.

Electrical Connections to the Controller

The installer should test to confirm that no voltage is present at any of the wires during installation.

Powered Input Connections

System Pump Contact

The Pump terminals (13 and 14 on the controller to pins 4 and 5 on P3) are an isolated output in the controller. There is no power available on these terminals from the controller. This output is to be used as a switch to either make or break power to the system pump. Since this is an isolated contact, it may switch voltage up to 120 VAC that does not to exceed 5 amps. For larger pumps, a contactor must be used.

Heater Contacts

The Stg 1, Stg 2, Stg 3 and Stg 4 terminals (15 through 22) are isolated outputs in the Controller. There is no power available on these terminals from the Controller. These terminals are to be used as a switch to either make or break the heater circuit. When the Controller requires heater stages to fire, it closes the contact between the appropriate terminals.

Alarm Contact

For field-installations, terminals 19 and 20 provide dry contacts for an alarm. For factory-installations, the alarm is installed with a UDB diagnostic control (when available). The UDB provides the alarm dry contacts.

Sensor and Unpowered Input Connections

NOTE: Do not apply power to these terminals as this damages the Controller.

Outdoor Sensor

Connect the two wires from the optional outdoor sensor to the Com (common sensor) and Air (outdoor air sensor) terminals (4 and 5). The outdoor sensor is used by the

Controller to measure the outdoor air temperature for use in outdoor reset operation (mode 5). These contacts are disregarded in other modes. This is a potted 10 k Ω sensor inside an enclosure.

Heater Outlet Sensor (Field-Install)

Connect the two wires from the Heater Outlet Sensor to the Com (common sensor) and the Boil Out (heater outlet sensor) terminals (4 and 7). The heater outlet sensor is used by the Controller to measure the heater outlet water temperature from the heater.

NOTE: The heater outlet sensor is required for every mode of operation.

Heater Inlet Sensor (Field-Install)

Connect the two wires from the Heater Inlet Sensor to the Com (common sensor) and the Boil In (heater inlet sensor) terminals (4 and 8). The heater inlet sensor is used by the Controller to measure the heater inlet water temperature to the heater.

Heater Sys/D or DHW Sensor

Either a System Sensor or DHW Sensor may be connected to the Controller. If a sensor is used, connect the two wires from the sensor to the Com (common sensor) and the Sys/D (demand/DHW sensor) terminals (4 and 6).

6. TROUBLESHOOTING

Field-Testing the Power Supply

Verify that all exposed wires and bare terminals are not in contact with other wires or grounded surfaces. Turn on the power and measure the voltage between the 1 and 2 terminals on the P3 terminal block, using an AC voltmeter. The reading should be 120 VAC \pm 10%, and the reading between terminals 2 and 3 must be less than 1.0 VAC.

Verify the power at the transformer by using the AC voltmeter across pins 1 and 4 of terminal block P1. The reading should be between 22 VAC and 26 VAC.

CAUTION: The sensor must be disconnected in order to measure the correct ohms.

Testing the Sensors (10 k Ω)

In order to test the sensors, the actual temperature at each sensor location must be measured.

Using **Table F on page 16**, estimate the temperature measured by the sensor, based on ohm readings from various sensors to COM.

The sensor and thermometer readings should be close. If the meter reads a very high resistance, there may be a broken wire, a poor wiring connection or a defective sensor. If the resistance is very low, the wiring may be shorted, there may be moisture in the sensor or the sensor

may be defective. To test for a defective sensor, measure the resistance directly at the sensor location.

Testing the Enable/Disable and DHW Field-Install Inputs

When the Enable/Disable system calls for heat, you should measure between 22 VAC and 26 VAC at terminals 2 and 4 on P1. When the heat demand device is off, you should measure less than 1 VAC. For DHW override, use terminals 3 and 4.

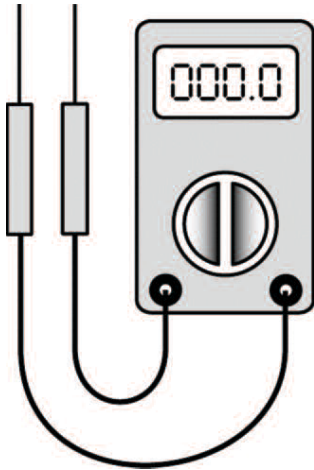


Figure 21. Multi-meter

NOTE: Make sure ALL power to the devices and wiring harness is off.

Connecting the Controller

Apply power to the Controller. The operation of the Controller on power up is described in "Sequence of Operation" on page 6 of this manual.

Testing the Controller's Outputs

The Controller has a built-in test routine, which is used to test the main control functions. The test sequence is enabled when the ▲ button is pressed and held for 3 seconds while in the View menu. The outputs are tested in the following sequence:

1. After 1 second, the pump is turned on.
2. After 4 seconds, Stage 1 is turned on.
3. After 7 seconds, Stage 2 is turned on.
4. After 10 seconds, Stage 3 is turned on.
5. After 13 seconds, Stage 4 is turned on.
6. After 16 seconds, the pump and stages 1 to 4 are shut off. The alarm contacts are closed for 10 seconds.
7. The control exits the test sequence and resumes normal operation.

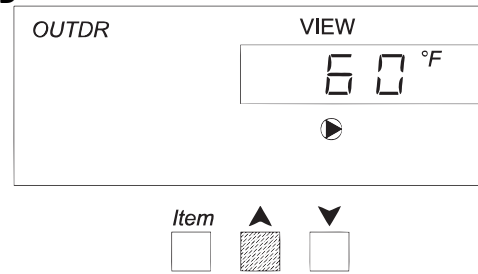


Figure 22. Testing the Controller's Outputs

Sensor Resistance

Temperature °F (°C)	Resistance (Ω)
-50 (-45.6)	490,813
-40 (-40)	336,606
-30 (-34.4)	234,196
-20 (-28.9)	165,180
-10 (-23.3)	118,018
0 (-17.8)	85,362
10 (-12.2)	62,465
20 (-6.7)	46,218
30 (-1.1)	34,558
40 (4.4)	26,099
50 (10)	19,900
60 (15.6)	15,311
70 (21.1)	11,883
77 (25)	10,000
80 (26.7)	9,299
90 (32.2)	7,334
100 (37.8)	5,828
110 (43.3)	4,665
120 (48.9)	3,760
130 (54.4)	3,050
140 (60)	2,490
150 (65.6)	2,045
160 (71.1)	1,689
170 (76.7)	1,403
180 (82.2)	1,172
190 (87.8)	983
200 (93.3)	829
210 (98.9)	703
220 (104.4)	598

Table F. Sensor Resistance

7. ELECTRICAL WIRING /TROUBLESHOOTING

Pin #	Label	Function
1	CD	24 VAC return power.
2	Dem 1	Enable/Disable - Hot 24 VAC - Incoming power for the Controller. Bring hot 24 VAC from the heater transformer.
3	Dem 2	Indirect DHW Override – Hot 24 VAC – Incoming power for the demand. Open or close contacts to supply hot 24 VAC for indirect DHW override.
4	Com	Outdoor Sensor (if used)
5	Out	Outdoor Sensor (if used)
6	Sys/D	System/Demand Sensor - This is the primary water temperature sensor.
7	Boil O	Heater Outlet Sensor
8	Boil In	Heater Inlet Sensor
9	COM/-	Common return lead for all of the sensors. If all 3 are used, connect the return leads here.
10	+V (in)	Used for modes 6, 7 or 8 for external input of 0-10 VDC or 2-10 VDC. Use terminal 9 for common lead.
11		Not used
12	C	24 VAC return power

Pin #	Label	Function
13	Pmp	Pump Contact – Not to exceed 5 amps. No power output.
14	Pmp	Pump Contact – Not to exceed 5 amps. No power output.
15	Stg 1	Stage 1, Odd-numbered pin on the stage connection plug
16	Stg 1	Stage 1, Even-numbered pin on the stage connection plug
17	Stg 2	Stage 2, Odd-numbered pin on the stage connection plug
18	Stg 2	Stage 2, Even-numbered pin on the stage connection plug
19	Stg 3	Stage 3, Odd-numbered pin on the stage connection plug
20	Stg 3	Stage 3, Even-numbered pin on the stage connection plug
21	Stg 4	Stage 4, Odd-numbered pin on the stage connection plug
22	Stg 4	Stage 4, Even-numbered pin on the stage connection plug
23	Alarm	Alarm notification circuit - may draw up to 72 VA
24	R	Hot 24 VAC - Incoming power to the Controller

Table G. Control Pin-outs

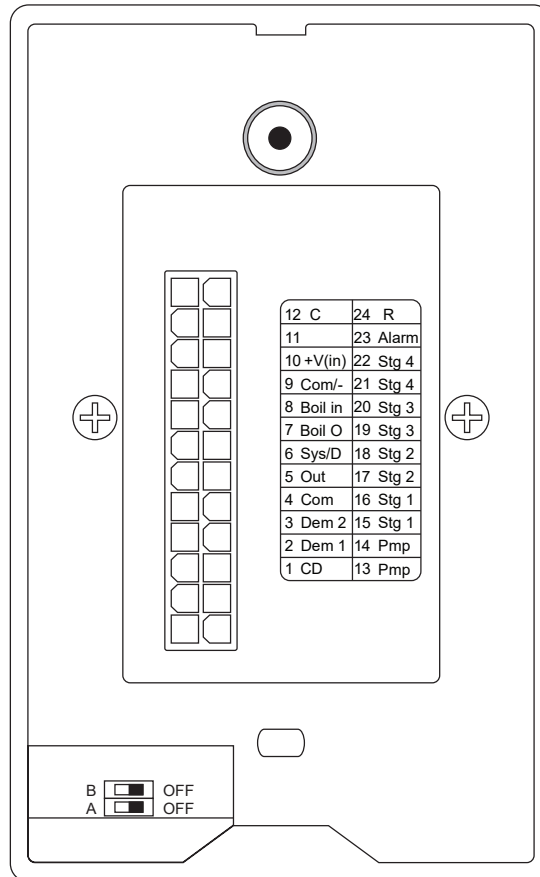


Figure 23. Electrical Connections

8. WIRING CONNECTIONS

Factory-Mounted

On Delta Limited heaters, the multi-stage Temp Tracker can be ordered factory-mounted. The controller is already powered by the heater, the inlet and outlet sensors are installed in the inlet/outlet header, and the controller alarm is connected to the UDB diagnostic board. The heater stage connections are also wired.

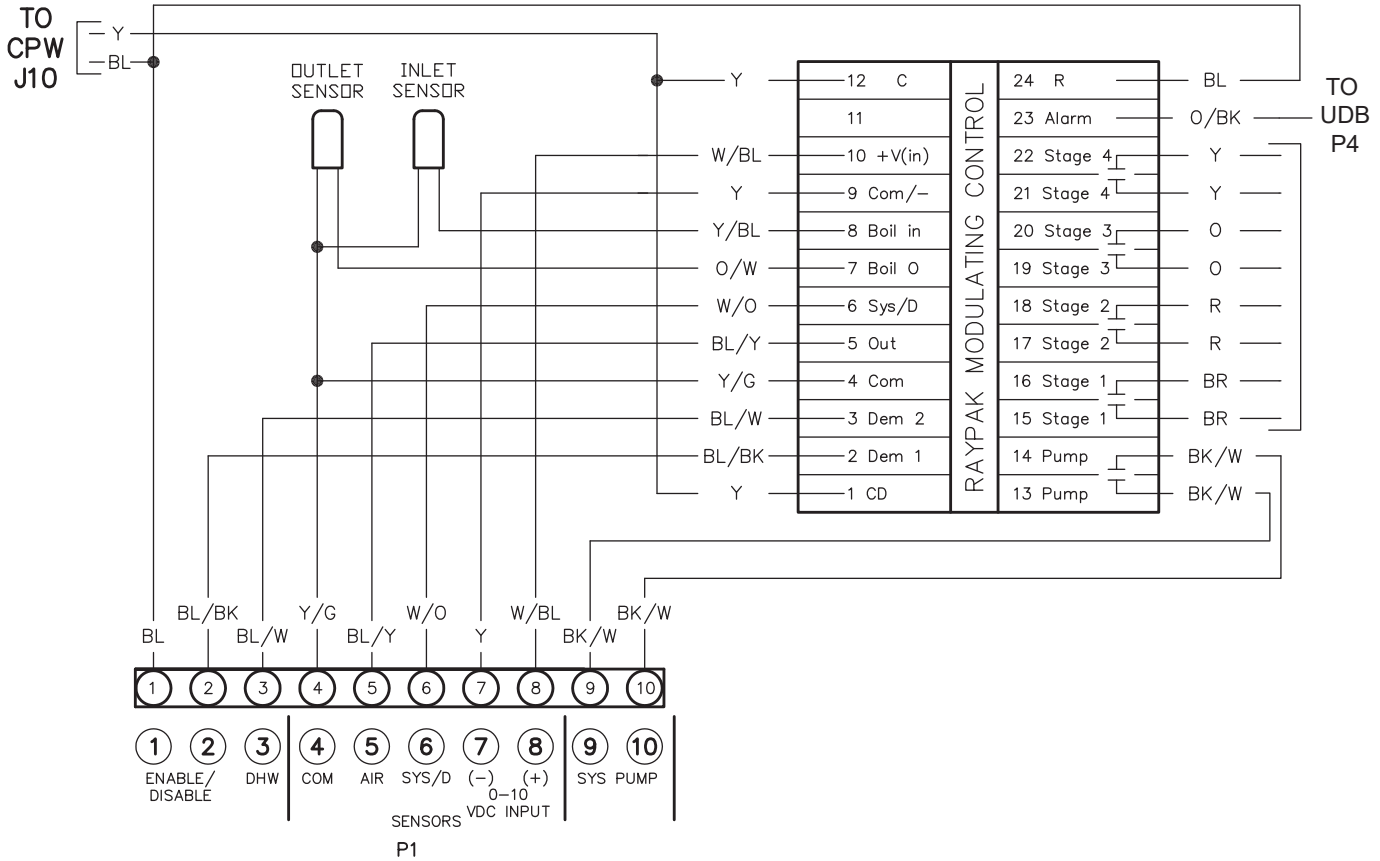


Figure 24. Wiring Diagram (Factory-Mounted)

Field-Installation

Field wiring must be connected to the terminal block on the back side of the controller mounting bracket. Follow the wiring diagram as specified in **Figure 25** below.

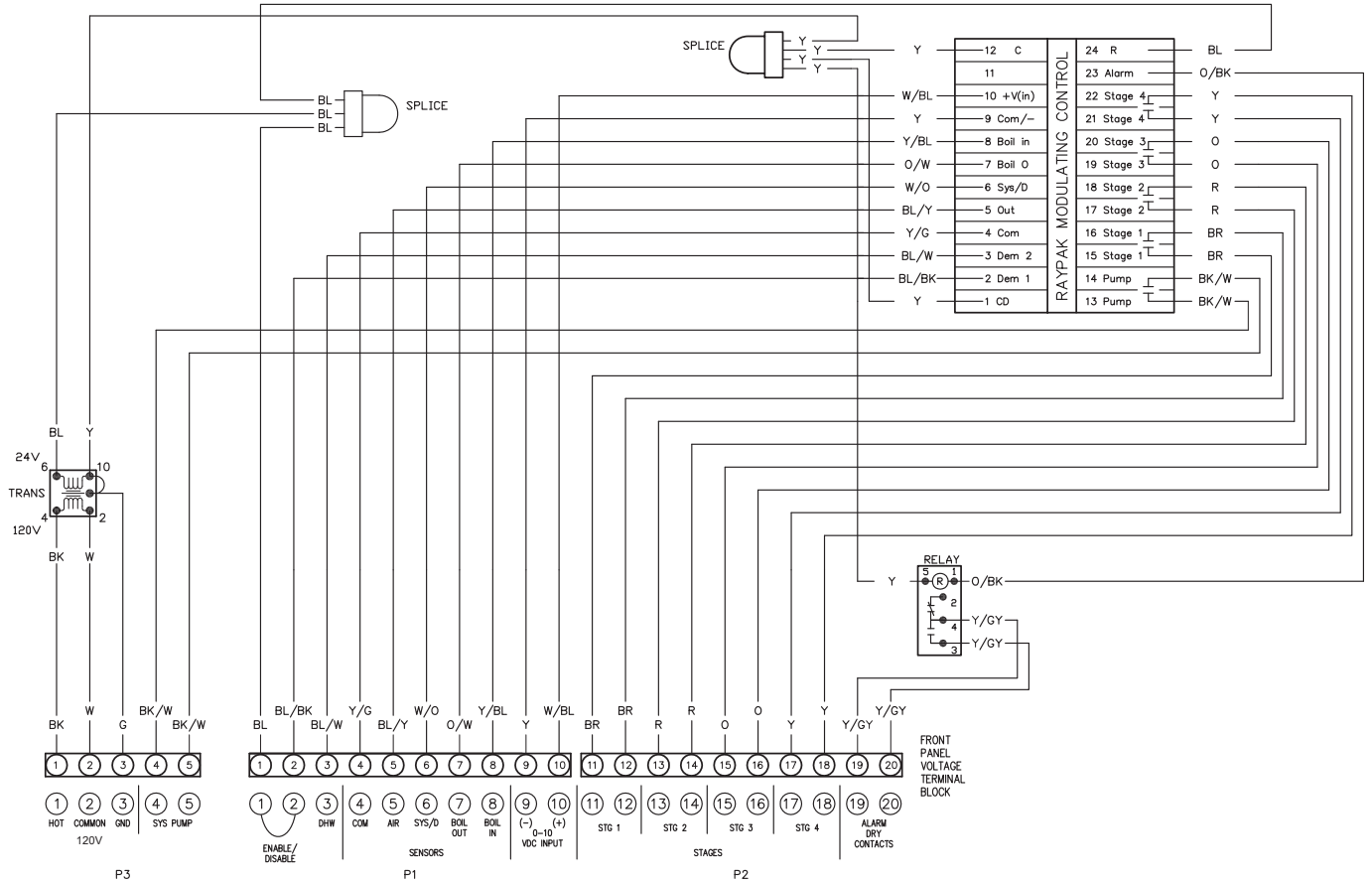


Figure 25. Wiring Diagram (Field-Installation)

9. CONTROLLER SETTINGS

Table H through Table Q describe the VIEW and ADJUST menus. They also show the default settings as well as any possible adjustment ranges.

View Menu (Mode 2)

(With Default Settings Shown)

The View menu items display current operating temperatures and system status information. Use the Item button (see Figure 5) to view items in this menu.

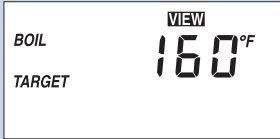

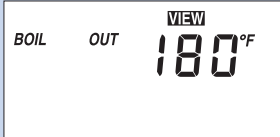
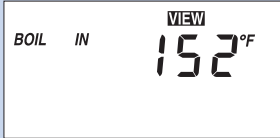
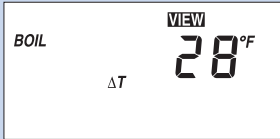
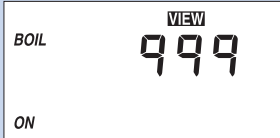
Item Field	Range	Description
	---, 35 to 266°F (2 to 130°C), OFF	BOILER TARGET The boiler target is the temperature the control is currently trying to maintain at the boiler supply sensor or the boiler outlet sensor.
	-20 to 266°F (-29 to 130°C)	BOILER SUPPLY Current boiler supply water temperature as measured by the boiler supply sensor. Note: This item is only available when MODE is set to 2.
	-20 to 266°F (-29 to 130°C)	BOILER OUTLET Current boiler outlet water temperature as measured by the boiler outlet sensor. Note: When MODE is set to 2 this item is only visible in the Factory access level.
	-20 to 266°F (-29 to 130°C)	BOILER INLET Current boiler inlet water temperature as measured by the boiler inlet sensor. Note: This item is only available when a boiler inlet sensor is installed.
	0 to 252°F (0 to 140°C)	BOILER DELTA T Current temperature difference between the boiler outlet sensor and the boiler inlet sensor. Note: This item is only available when a boiler inlet sensor is installed.
	0 to 999	BOILER ON HOURS The total number of running hours of the boiler since this item was last cleared. Clear the numbers of hours by pressing and holding the ▲ and ▼ buttons together while viewing this item.

Table H. View Menu, Mode 2
UNCONTROLLED DOCUMENT IF PRINTED

Adjust Menu (Mode 2)

(Page 1 of 2 with Default Settings Shown)

The Adjust menu items are the programmable settings used to operate the system. Press and hold all three buttons for one second to enter the Adjust menu, then select the desired item using the Item button. Finally, use the ▲ or ▼ button to make the adjustment (see **Figure 6**).

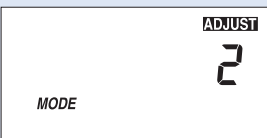

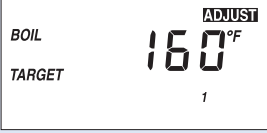
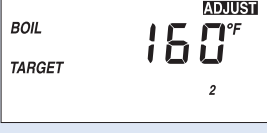




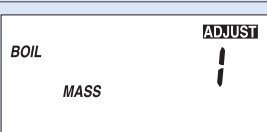
Item Field	Range	Description	Setting
 <p>MODE 2</p>	1 to 8	MODE Select the operating mode for the control.	
 <p>STGMODE Pld</p>	Pld or P	STAGE MODE Select the staging operation to be either automatic or manual. (Pld = automatic) (P = proportional)	
 <p>BOIL TARGET 160°F</p>	OFF, 70 to 230°F (21 to 110°C)	BOILER TARGET 1 Select the boiler target temperature while a heat demand is present.	
 <p>BOIL TARGET 160°F</p>	OFF, 70 to 230°F (21 to 110°C)	BOILER TARGET 2 Select the boiler target temperature while a setpoint demand is present.	
 <p>BOIL OUT MAX 200°F</p>	120 to 235°F (49 to 113°C)	BOILER OUTLET MAXIMUM Select the maximum boiler outlet temperature. Exceeding this temperature shuts off the burners.	
 <p>BOIL MAX 200°F</p>	120 to 235°F (49 to 113°C), OFF	BOILER MAXIMUM Select the maximum boiler target temperature.	
 <p>BOIL MIN 125°F</p>	OFF, 80 to 180°F (27 to 82°C)	BOILER MINIMUM Select the minimum boiler target temperature.	
 <p>DLY 0:45 min</p>	0:00 to 3:00 min (1 second increments)	FIRE DELAY Select the amount of time required for combustion pre-purging, ignition and the flame to be established. Note: This setting is only available when STAGE MODE is set to Pld.	
 <p>BOIL MASS 1</p>	1 (Lo) or 2 (Med) or 3 (Hi)	BOILER MASS Select the thermal mass of the boiler. Note: This setting is only available when STAGE MODE is set to Pld.	

Table I. Adjust Menu, Mode 2 (page 1 of 2)

APPROVED

Adjust Menu (Mode 2)

(Page 2 of 2 with default settings shown)

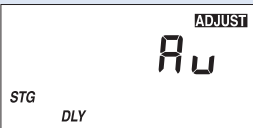


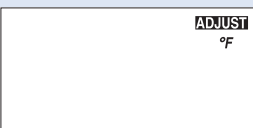

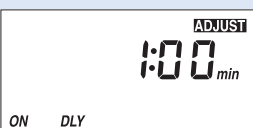



Item Field	Range	Description	Setting
	Au, 0:30 to 9:55 min	STAGE DELAY Select the minimum time delay between stages. Note: This setting is only available when STAGE MODE is set to Pld.	
	Au, 2 to 42°F (1 to 23°C)	DIFFERENTIAL Select the boiler differential. Note: The automatic setting is only available when STAGE MODE is set to Pld staging.	
	OFF, 0:20 to 9:55 min, On	PUMP DELAY Select the system pump purge time after shutting off the burner.	
	°F or °C	TEMPERATURE UNITS Select to display temperature in degrees Fahrenheit or in degrees Celsius.	
	0 to 10°F (0 to 6°C)	STAGE DIFFERENTIAL Select the interstage temperature differential between stages for proportional staging. Note: This setting is only available when STAGE MODE is set to P.	
	0:10 to 8:00 min	INTERSTAGE ON DELAY Select the amount of time that must pass once a stage has been turned on in order to allow the next stage to turn on. Note: This setting is only available when STAGE MODE is set to P.	
	0:10 to 4:00 min	INTERSTAGE OFF DELAY Select the amount of time that must pass once a stage has been turned off in order to allow the next stage to turn off. Note: This setting is only available when STAGE MODE is set to P.	
	0:10 to 5:00 min	MINIMUM ON TIME Select the minimum amount of time that the stage contact must remain on before it is allowed to turn off. Note: This setting is only available when STAGE MODE is set to P.	
	0:10 to 5:00 min	MINIMUM OFF TIME Select the minimum amount of time that the stage contact must remain off before it is allowed to turn back on. Note: This setting is only available when STAGE MODE is set to P.	

Table I. Adjust Menu, Mode 2 (page 2 of 2)

UNCONTROLLED DOCUMENT IF PRINTED

View Menu (Mode 3)

(With Default Settings Shown)

The View menu items display current operating temperatures and system status information. Use the Item button (see **Figure 5**) to view items in this menu.


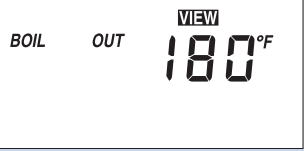
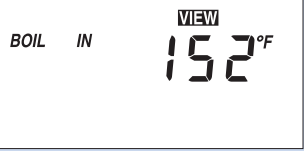
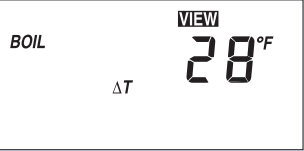

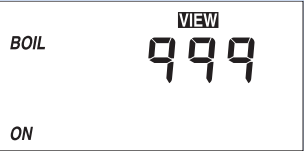
Item Field	Range	Description
	---, 35 to 266°F (2 to 130°C), OFF	TANK TARGET The temperature that the control is trying to maintain in the tank.
	-20 to 266°F (-29 to 130°C)	BOILER OUTLET Current boiler outlet water temperature as measured by the boiler outlet sensor. At an outlet temp of 180°F (82°C), a WH unit will probably trip on an outlet limit sensor.
	-20 to 266°F (-29 to 130°C)	BOILER INLET Current boiler inlet water temperature as measured by the boiler inlet sensor. Note: This item is only available when a boiler inlet sensor is installed.
	0 to 252°F (0 to 140°C)	BOILER DELTA T Current temperature difference between the boiler outlet sensor and the boiler inlet sensor. Note: This item is only available when a boiler inlet sensor is installed.
	-20 to 266°F (-29 to 130°C)	TANK Current domestic hot water tank temperature as measured by the DHW tank sensor.
	0 to 999	BOILER ON HOURS The total number of running hours of the boiler since this item was last cleared. Clear the numbers of hours by pressing and holding the ▲ and ▼ buttons together while viewing this item.

Table J. View Menu, Mode 3

Adjust Menu (Mode 3)

(Page 1 of 2 with Default Settings Shown)

The Adjust menu items are the programmable settings used to operate the system. Press and hold all three buttons for one second to enter the Adjust menu, then select the desired item using the Item button. Finally, use the ▲ or ▼ button to make the adjustment (see **Figure 6**).




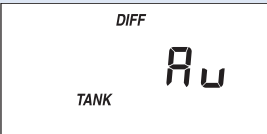


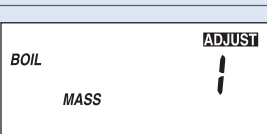
Item Field	Range	Description	Setting
 <p>MODE</p>	1 to 8	MODE Select the operating mode for the control.	
 <p>STG MODE</p>	Pld or P	STAGE MODE Select the staging operation to be either automatic or manual. (Pld = automatic) (P = proportional)	
 <p>TARGET TANK</p>	OFF, 70 to 190°F (21 to 88°C)	TANK TARGET Select the dedicated domestic hot water tank target temperature.	
 <p>DIFF TANK</p>	Au, 2 to 42°F (1 to 23°C)	TANK DIFFERENTIAL Select the dedicated domestic hot water tank differential. The DHW sensor temperature must fall below this setting before the burners will turn on.	
 <p>BOILER OUT MAX</p>	120 to 225°F (49 to 107°C)	BOILER OUTLET MAXIMUM Select the maximum boiler outlet temperature. Exceeding this temperature shuts off the burners.	
 <p>DLY</p>	0:00 to 3:00 min (1 second increments)	FIRE DELAY Select the amount of time required for combustion pre-purging, ignition and the flame to be established. Note: This setting is only available when STAGE MODE is set to Pld.	
 <p>BOILER MASS</p>	1 (Lo) or 2 (Med) or 3 (Hi)	BOILER MASS Select the thermal mass of the boiler. Note: This setting is only available when STAGE MODE is set to Pld.	

Table K. Adjust Menu, Mode 3 (page 1 of 2)

APPROVED

Adjust Menu (Mode 3)

(Page 2 of 2 with Default Settings Shown)





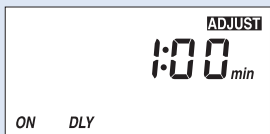

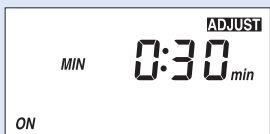
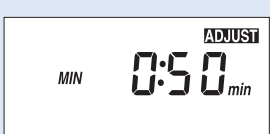
Item Field	Range	Description	Setting
	Au, 0:30 to 9:55 min	STAGE DELAY Select the minimum time delay between stages. Note: This setting is only available when STAGE MODE is set to PId.	
	OFF, 0:20 to 9:55 min, On	PUMP DELAY Select the system pump purge time after shutting off the burner.	
	°F or °C	TEMPERATURE UNITS Select to display temperature in degrees Fahrenheit or in degrees Celsius.	
	2 to 42°F (1 to 23°C)	STAGE DIFFERENTIAL Select the interstage temperature differential between stages for proportional staging. Note: This setting is only available when STAGE MODE is set to P.	
	0:10 to 8:00 min	INTERSTAGE ON DELAY Select the amount of time that must pass once a stage has been turned on in order to allow the next stage to turn on. Note: This setting is only available when STAGE MODE is set to P.	
	0:10 to 4:00 min	INTERSTAGE OFF DELAY Select the amount of time that must pass once a stage has been turned off in order to allow the next stage to turn off. Note: This setting is only available when STAGE MODE is set to P.	
	0:10 to 5:00 min	MINIMUM ON TIME Select the minimum amount of time that the stage contact must remain on before it is allowed to turn off. Note: This setting is only available when STAGE MODE is set to P.	
	0:10 to 5:00 min	MINIMUM OFF TIME Select the minimum amount of time that the stage contact must remain off before it is allowed to turn back on. Note: This setting is only available when STAGE MODE is set to P.	

Table K Adjust Menu, Mode 3 (page 2 of 2)

View Menu (Mode 5)

(With Default Settings Shown)

The View menu items display current operating temperatures and system status information. Use the Item button (see **Figure 5**) to view items in this menu.

Item Field	Range	Description
<p>OUTDR VIEW 63^{°F}</p>	-60 to 190°F (-51 to 88°C)	OUTDOOR Current outdoor air temperature as measured by the outdoor sensor.
<p>BOIL TARGET VIEW 180^{°F}</p>	---, 35 to 266°F (2 to 130°C), OFF	BOILER TARGET The boiler target is the temperature the control is currently trying to maintain at the boiler supply sensor or the boiler outlet sensor.
<p>BOILSUP VIEW 178^{°F}</p>	-20 to 266°F (-29 to 130°C)	BOILER SUPPLY Current boiler supply water temperature as measured by the boiler supply sensor. Note: This item is only available when MODE is set to 5.
<p>BOIL OUT VIEW 180^{°F}</p>	-20 to 266°F (-29 to 130°C)	BOILER OUTLET Current boiler outlet water temperature as measured by the boiler outlet sensor. Note: When MODE is set to 5 this item is only visible in the Factory access level.
<p>BOIL IN VIEW 152^{°F}</p>	-20 to 266°F (-29 to 130°C)	BOILER INLET Current boiler inlet water temperature as measured by the boiler inlet sensor. Note: This item is only available when a boiler inlet sensor is installed.
<p>BOIL ΔT VIEW 28^{°F}</p>	0 to 252°F (0 to 140°C)	BOILER DELTA T Current temperature difference between the boiler outlet sensor and the boiler inlet sensor. Note: This item is only available when a boiler inlet sensor is installed.
<p>BOIL ON VIEW 999</p>	0 to 999	BOILER ON HOURS The total number of running hours of the boiler since this item was last cleared. Clear the numbers of hours by pressing and holding the ▲ and ▼ buttons together while viewing this item.

Table L. View Menu, Mode 5
UNCONTROLLED DOCUMENT IF PRINTED

Adjust Menu (Mode 5)

(Page 1 of 3 with Default Settings Shown)

The Adjust menu items are the programmable settings used to operate the system. Press and hold all three buttons for one second to enter the Adjust menu, then select the desired item using the Item button. Finally, use the ▲ or ▼ button to make the adjustment (see **Figure 6**).



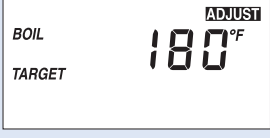
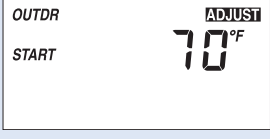
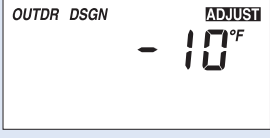
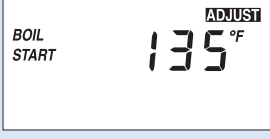


Item Field	Range	Description	Setting
	1 to 8	MODE Select the operating mode for the control.	
	Pld or P	STAGE MODE Select the staging operation to be either automatic or manual. (Pld = automatic) (P = proportional)	
	OFF, 70 to 220°F (21 to 104°C)	BOILER TARGET Select the boiler target temperature while a setpoint demand is present.	
	35 to 85°F (2 to 29°C)	OUTDOOR START Select the outdoor starting temperature used in the reset ratio for the heating system. Typically set to the desired building temperature.	
	-60 to 32°F (-51 to 0°C)	OUTDOOR DESIGN Select the outdoor design temperature used in the reset ratio for the heating system. Set to the coldest annual outdoor temperature in the local area.	
	35 to 150°F (2 to 66°C)	BOILER START Select the starting water temperature used in the reset ratio calculation for the heating system. Typically set to the desired building temperature.	
	70 to 230°F (21 to 110°C)	BOILER DESIGN Select the boiler design water temperature used in the reset ratio calculation for the heating system. Set to the boiler water temperature required to heat the building on the coldest annual outdoor temperature.	
	120 to 230°F (49 to 110°C)	BOILER OUTLET MAXIMUM Select the maximum boiler outlet temperature. Exceeding this temperature shuts off the burners.	

Table M. Adjust Menu, Mode 5 (page 1 of 3)
UNCONTROLLED DOCUMENT IF PRINTED

APPROVED

Adjust Menu (Mode 5)

(Page 2 of 3 with Default Settings Shown)

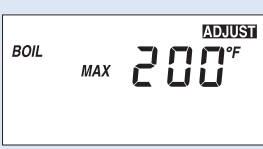


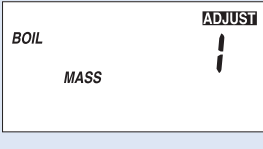
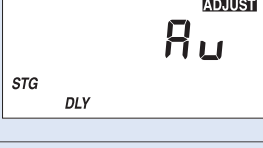
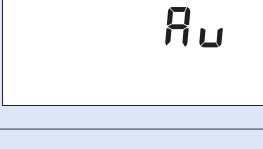
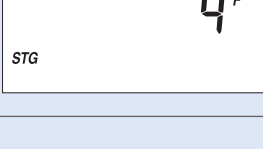

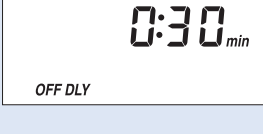
Item Field	Range	Description	Setting
	120 to 230°F (49 to 110°C), OFF	BOILER MAXIMUM Select the maximum boiler target temperature.	
	OFF, 80 to 180°F (27 to 82°C)	BOILER MINIMUM Select the minimum boiler target temperature.	
	0:00 to 3:00 min (1 second increments)	FIRE DELAY Select the amount of time required for combustion pre-purging, ignition and the flame to be established. Note: This setting is only available when STAGE MODE is set to Pld.	
	1 (Lo) or 2 (Med) or 3 (Hi)	BOILER MASS Select the thermal mass of the boiler. Note: This setting is only available when STAGE MODE is set to Pld.	
	Au, 0:30 to 9:55 min	STAGE DELAY Select the minimum time delay between stages. Note: This setting is only available when STAGE MODE is set to Pld.	
	Au, 2 to 42°F (1 to 23°C)	DIFFERENTIAL Select the boiler differential. Note: The automatic setting is only available when STAGE MODE is set to Pld staging.	
	0 to 10°F (0 to 6°C)	STAGE DIFFERENTIAL Select the interstage temperature differential between stages for proportional staging. Note: This setting is only available when STAGE MODE is set to P.	
	0:10 to 8:00 min	INTERSTAGE ON DELAY Select the amount of time that must pass once a stage has been turned on in order to allow the next stage to turn on. Note: This setting is only available when STAGE MODE is set to P.	
	0:10 to 4:00 min	INTERSTAGE OFF DELAY Select the amount of time that must pass once a stage has been turned off in order to allow the next stage to turn off. Note: This setting is only available when STAGE MODE is set to P.	

Table M. Adjust Menu, Mode 5 (page 2 of 3)

UNCONTROLLED DOCUMENT IF PRINTED

APPROVED

Adjust Menu (Mode 5)

(Page 3 of 3 with Default Settings Shown)

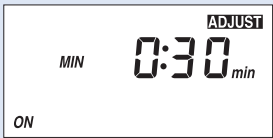
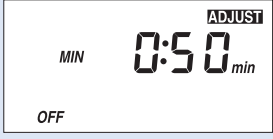

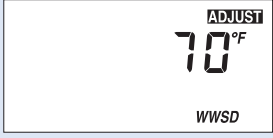
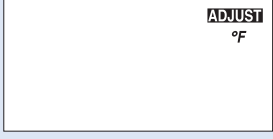
Item Field	Range	Description	Setting
	0:10 to 5:00 min	MINIMUM ON TIME Select the minimum amount of time that the stage contact must remain on before it is allowed to turn off. Note: This setting is only available when STAGE MODE is set to P.	
	0:10 to 5:00 min	MINIMUM OFF TIME Select the minimum amount of time that the stage contact must remain off before it is allowed to turn back on. Note: This setting is only available when STAGE MODE is set to P.	
	OFF, 0:20 to 9:55 min, On	PUMP DELAY Select the system pump purge time after shutting off the burner.	
	35 to 100°F (2 to 38°C), OFF	WARM WEATHER SHUT DOWN Select the heating system warm weather shut down for outdoor reset operation. Heat demands are ignored once the outdoor air temperature exceeds this setting.	
	°F or °C	TEMPERATURE UNITS Select to display temperature in degrees Fahrenheit or in degrees Celsius.	

Table M. Adjust Menu, Mode 5 (page 3 of 3)

View Menu (Mode 7)

(With Default Settings Shown)

The View menu items display current operating temperatures and system status information. Use the Item button (see **Figure 5**) to view items in this menu.

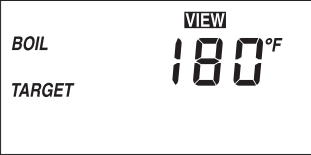

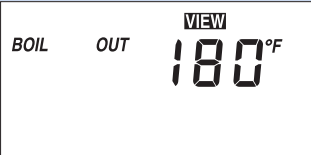
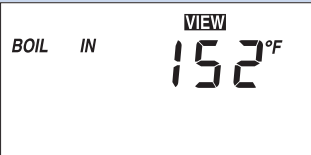
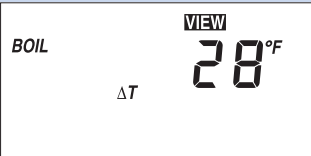
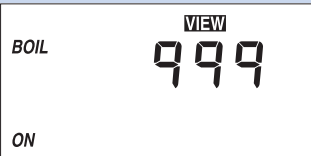
Item Field	Range	Description
 <p>BOILER TARGET</p>	<p>---, 35 to 266°F (2 to 130°C), OFF</p>	<p>BOILER TARGET The boiler target is the temperature the control is currently trying to maintain at the boiler supply sensor or the boiler outlet sensor.</p>
 <p>BOILER SUPPLY</p>	<p>-20 to 266°F (-29 to 130°C)</p>	<p>BOILER SUPPLY Current boiler supply water temperature as measured by the boiler supply sensor. Note: This item is only available when MODE is set to 7.</p>
 <p>BOILER OUTLET</p>	<p>-20 to 266°F (-29 to 130°C)</p>	<p>BOILER OUTLET Current boiler outlet water temperature as measured by the boiler outlet sensor. Note: When MODE is set to 7 this item is only visible in the Factory access level.</p>
 <p>BOILER INLET</p>	<p>-20 to 266°F (-29 to 130°C)</p>	<p>BOILER INLET Current boiler inlet water temperature as measured by the boiler inlet sensor. Note: This item is only available when a boiler inlet sensor is installed.</p>
 <p>BOILER ΔT</p>	<p>0 to 252°F (0 to 140°C)</p>	<p>BOILER DELTA T Current temperature difference between the boiler outlet sensor and the boiler inlet sensor. Note: This item is only available when a boiler inlet sensor is installed.</p>
 <p>BOILER ON</p>	<p>0 to 999</p>	<p>BOILER ON HOURS The total number of running hours of the boiler since this item was last cleared. Clear the numbers of hours by pressing and holding the ▲ and ▼ buttons together while viewing this item.</p>

Table N. View Menu, Mode 7
UNCONTROLLED DOCUMENT IF PRINTED

Adjust Menu (Mode 7)

(Page 1 of 2 with Default Settings Shown)

The Adjust menu items are the programmable settings used to operate the system. Press and hold all three buttons for one second to enter the Adjust menu, then select the desired item using the Item button. Finally, use the ▲ or ▼ button to make the adjustment (see **Figure 6**).



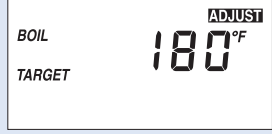



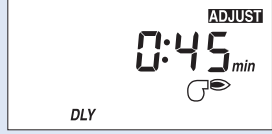
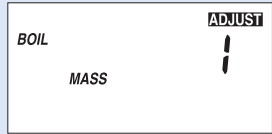


Item Field	Range	Description	Setting
 <p>MODE</p>	1 to 8	MODE Select the operating mode for the control.	
 <p>STG MODE</p>	PId or P	STAGE MODE Select the staging operation to be either automatic or manual. (PId = automatic) (P = proportional)	
 <p>BOILER TARGET</p>	OFF, 70 to 220°F (21 to 104°C)	BOILER TARGET Select the boiler target temperature while a setpoint demand is present.	
 <p>BOILER OUT MAX</p>	120 to 230°F (49 to 110°C)	BOILER OUTLET MAXIMUM Select the maximum boiler outlet temperature. Exceeding this temperature shuts off the burners.	
 <p>BOILER MAX</p>	120 to 230°F (49 to 110°C), OFF	BOILER MAXIMUM Select the maximum boiler target temperature.	
 <p>BOILER MIN</p>	OFF, 80 to 180°F (27 to 82°C)	BOILER MINIMUM Select the minimum boiler target temperature.	
 <p>DLY</p>	0:00 to 3:00 min (1 second increments)	FIRE DELAY Select the amount of time required for combustion pre-purging, ignition and the flame to be established. Note: This setting is only available when STAGE MODE is set to PId.	
 <p>BOILER MASS</p>	1 (Lo) or 2 (Med) or 3 (Hi)	BOILER MASS Select the thermal mass of the boiler. Note: This setting is only available when STAGE MODE is set to PId.	
 <p>STG DLY</p>	Au, 0:30 to 9:55 min	STAGE DELAY Select the minimum time delay between stages. Note: This setting is only available when STAGE MODE is set to PId.	
 <p>DIFF</p>	Au, 2 to 42°F (1 to 23°C)	DIFFERENTIAL Select the boiler differential. Note: The automatic setting is only available when STAGE MODE is set to PId staging.	

Table O. Adjust Menu, Mode 7 (page 1 of 2)
UNCONTROLLED DOCUMENT IF PRINTED

APPROVED

Adjust Menu (Mode 7)

(Page 1 of 2 with Default Settings Shown)

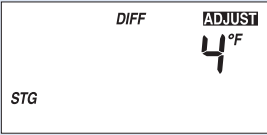



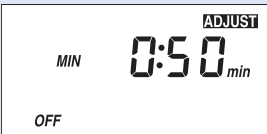
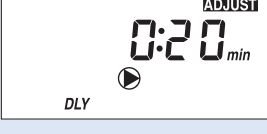
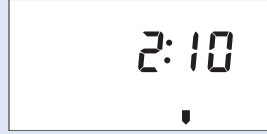


Item Field	Range	Description	Setting
 <p>STG DIFF ADJUST 4°F</p>	0 to 10°F (0 to 6°C)	STAGE DIFFERENTIAL Select the interstage temperature differential between stages for proportional staging. Note: This setting is only available when STAGE MODE is set to P.	
 <p>ON DLY ADJUST 1:00 min</p>	0:10 to 8:00 min	INTERSTAGE ON DELAY Select the amount of time that must pass once a stage has been turned on in order to allow the next stage to turn on. Note: This setting is only available when STAGE MODE is set to P.	
 <p>OFF DLY ADJUST 0:30 min</p>	0:10 to 4:00 min	INTERSTAGE OFF DELAY Select the amount of time that must pass once a stage has been turned off in order to allow the next stage to turn off. Note: This setting is only available when STAGE MODE is set to P.	
 <p>MIN ON ADJUST 0:30 min</p>	0:10 to 5:00 min	MINIMUM ON TIME Select the minimum amount of time that the stage contact must remain on before it is allowed to turn off. Note: This setting is only available when STAGE MODE is set to P.	
 <p>MIN OFF ADJUST 0:50 min</p>	0:10 to 5:00 min	MINIMUM OFF TIME Select the minimum amount of time that the stage contact must remain off before it is allowed to turn back on. Note: This setting is only available when STAGE MODE is set to P.	
 <p>DLY ADJUST 0:20 min</p>	OFF, 0:20 to 9:55 min, On	PUMP DELAY Select the system pump purge time after shutting off the burner.	
 <p>External Input Signal 2:10</p>	0:10 or 2:10	EXTERNAL INPUT SIGNAL Select the range of the external input signal.	
 <p>Offset 0°F</p>	-10 to +10°F (-6 to +6°C)	OFFSET Select the amount of offset when the boiler target is determined from an external input signal.	
 <p>TEMPERATURE UNITS ADJUST °F</p>	°F or °C	TEMPERATURE UNITS Select to display temperature in degrees Fahrenheit or in degrees Celsius.	

Table O. Adjust Menu, Mode 7 (page 2 of 2)

UNCONTROLLED DOCUMENT IF PRINTED

View Menu (Mode 8)

(With Default Settings Shown)

The View menu items display current operating temperatures and system status information. Use the Item button (see **Figure 5**) to view items in this menu.

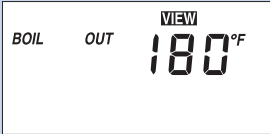
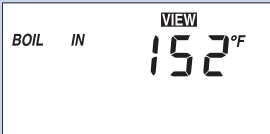
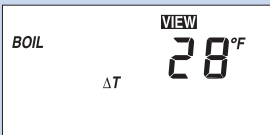
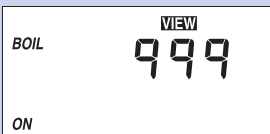
Item Field	Range	Description
	-20 to 266°F (-29 to 130°C)	BOILER OUTLET Current boiler outlet water temperature as measured by the boiler outlet sensor.
	-20 to 266°F (-29 to 130°C)	BOILER INLET Current boiler inlet water temperature as measured by the boiler inlet sensor. Note: This item is only available when a boiler inlet sensor is installed.
	0 to 252°F (0 to 140°C)	BOILER DELTA T Current temperature difference between the boiler outlet sensor and the boiler inlet sensor. Note: This item is only available when a boiler inlet sensor is installed.
	0 to 999	BOILER ON HOURS The total number of running hours of the boiler since this item was last cleared. Clear the numbers of hours by pressing and holding the ▲ and ▼ buttons together while viewing this item.

Table P. View Menu, Mode 8

Adjust Menu (Mode 8)

(With Default Settings Shown)

The Adjust menu items are the programmable settings used to operate the system. Press and hold all three buttons for one second to enter the Adjust menu, then select the desired item using the Item button. Finally, use the ▲ or ▼ button to make the adjustment (see **Figure 6**).

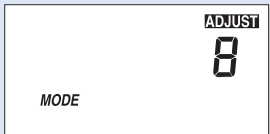
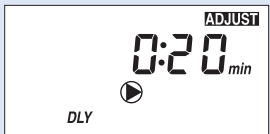
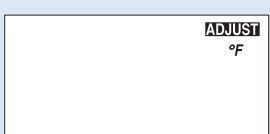
Item Field	Range	Description	Setting
	1 to 8	MODE Select the operating mode for the control.	
	OFF, 0:20 to 9:55 min, On	PUMP DELAY Select the system pump purge time after shutting off the burner.	
	°F or °C	TEMPERATURE UNITS Select to display temperature in degrees Fahrenheit or in degrees Celsius.	

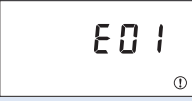


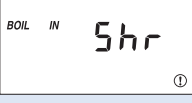

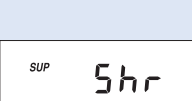
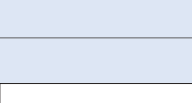
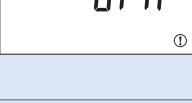
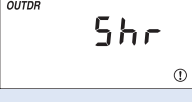

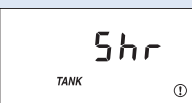
Table Q. Adjust Menu, Mode 8
UNCONTROLLED DOCUMENT IF PRINTED

Error Messages (All Modes)

Any error message energizes the alarm circuit.

For factory-mounted controllers on the Delta Limited product line, any error message is reported to the UDB as a controller alarm fault.

For field-mounted controllers, any error message energizes the alarm relay to yield continuity across pins 19 and 20 on the terminal block.

	<p>E01</p> <p>The control was unable to read a piece of information from its EEPROM memory. The control will stop operation until all settings in the Adjust menu have been checked by the user or installer. To clear the error message, set Access Level DIP Switch A to Factory (on position), then check all Adjust menu items.</p>
	<p>BOILER OUTLET SENSOR SHORT CIRCUIT</p> <p>The control is no longer able to read the boiler outlet sensor due to a short circuit. In this case, if the boiler inlet sensor is present and operational, the control will operate using the boiler inlet sensor. Otherwise, the control will not operate the burner.</p> <p>Test the boiler outlet sensor and related wiring. The error message will clear once the error condition is corrected and a button is pressed.</p>
	<p>BOILER OUTLET SENSOR OPEN CIRCUIT</p> <p>The control is no longer able to read the boiler outlet sensor due to an open circuit. In this case, if the boiler inlet sensor is present and operational, the control will operate using the boiler inlet sensor. Otherwise, the control will not operate the burner.</p> <p>Test the boiler outlet sensor and related wiring. The error message will clear once the error condition is corrected and a button is pressed.</p>
	<p>BOILER INLET SENSOR SHORT CIRCUIT</p> <p>The control is no longer able to read the boiler inlet sensor due to a short circuit. In this case, the control will continue operation.</p> <p>Test the boiler inlet sensor and related wiring. The error message will clear once the error condition is corrected and a button is pressed.</p>
	<p>BOILER INLET SENSOR OPEN CIRCUIT</p> <p>The control is no longer able to read the boiler inlet sensor due to an open circuit. In this case, the control will continue operation.</p> <p>Test the boiler inlet sensor and related wiring. The error message will clear once the error condition is corrected and a button is pressed.</p>
	<p>BOILER SUPPLY SENSOR SHORT CIRCUIT</p> <p>The control is no longer able to read the boiler supply sensor due to a short circuit. In this case, if the boiler outlet sensor is operational, the control will operate based on the boiler outlet sensor. If the boiler outlet sensor is not available and the boiler inlet sensor is present and operational, the control will operate using the boiler inlet sensor. Otherwise, the control will not operate the burner.</p> <p>Test the boiler supply sensor and related wiring. The error message will clear once the error condition is corrected and a button is pressed.</p>
	<p>BOILER SUPPLY SENSOR OPEN CIRCUIT</p> <p>The control is no longer able to read the boiler supply sensor due to an open circuit. In this case, if the boiler outlet sensor is operational, the control will operate based on the boiler outlet sensor. If the boiler outlet sensor is not available and the boiler inlet sensor is present and operational, the control will operate using the boiler inlet sensor. Otherwise, the control will not operate the burner.</p> <p>Test the boiler supply sensor and related wiring. The error message will clear once the error condition is corrected and a button is pressed.</p>
	<p>OUTDOOR SENSOR SHORT CIRCUIT</p> <p>The control is no longer able to read the outdoor sensor due to a short circuit. In this case the control assumes an outdoor temperature of 32°F (0°C) and continues operation.</p> <p>Test the outdoor sensor and related wiring. The error message will clear once the error condition is corrected and a button is pressed.</p>
	<p>OUTDOOR SENSOR OPEN CIRCUIT</p> <p>The control is no longer able to read the outdoor sensor due to an open circuit. In this case the control assumes an outdoor temperature of 32°F (0°C) and continues operation.</p> <p>Test the outdoor sensor and related wiring. The error message will clear once the error condition is corrected and a button is pressed.</p>
	<p>DHW TANK SENSOR SHORT CIRCUIT</p> <p>The control is no longer able to read the DHW tank sensor due to a short circuit. In this case, the control will not operate the burner.</p> <p>Test the DHW tank sensor and related wiring. The error message will clear once the error condition is corrected and a button is pressed.</p>
	<p>DHW TANK SENSOR OPEN CIRCUIT</p> <p>The control is no longer able to read the DHW tank sensor due to an open circuit. In this case, the control will not operate the burner.</p> <p>Test the DHW tank sensor and related wiring. The error message will clear once the error condition is corrected and a button is pressed.</p>

**Table R. Error Messages
UNCONTROLLED DOCUMENT IF PRINTED**

10. TECHNICAL DATA

(Controller only)

2-Stage Controller – Kit 009861F

4-Stage Controller – Kit 009862F

Item	Properties
Controller	Microprocessor PID control; This is not a safety (limit) control
Enclosure	Enclosure D, black Noryl plastic
Dimensions	4-3/4" H x 2-7/8" W x 1-7/8" D (120 x 74 x 48 mm)
Approvals	CSA C US, meets ICES & FCC regulations for EMI/RFI
Ambient Conditions	-40 to 140 °F (-40 to -60°C), <90% RH non-condensing
Power Supply	24 VAC ±10% 50/60 Hz
Demands	24VAC 3 VA without alarm; 24 VAC 75 VA with alarm
Pump/Stage 1 Relay	120 VAC 5 A 1/6 hp, pilot duty 240 VA
Stage 2 to 4 Relays	120 VAC 3 A 1/6 hp
Alarm Relay	24 VAC 3 A 1/6 hp
Sensors	NTC thermistor, 10kΩ @ 77 °F (25°C ±0.2°C) 3 universal water sensors - Kit 010787F 1 outdoor air sensor - Kit 010786F

Table S. Technical Data

11. QUICK START SET-UP & PROGRAMMING TIPS

- Determine piping arrangement and mode number as depicted in "Modes of Operation (Mode)" on page 7.
- Install system sensor and air sensor (for mode 5 only) as positioned in the mode arrangements located on page 8.
- Wire the sensors to the Controller as described in Figure 25 on page 19.
- Ensure that entire system is ready to start.
 - Water piping properly filled and purged.
 - Gas pipe properly installed and purged.
 - Electrical connections properly installed in conduit.
 - Vent properly installed and terminated.
 - Sensor wires properly routed in separate conduit.
- Turn on heater power to allow programming the Controller.
- After piping mode has been determined, program Controller as described on page 7 through page 9. Remember that the "Item", "▲" & "▼" buttons (all three) must be pressed simultaneously for one second to enter the program mode.
- Use mode settings as a guide to set up the Controller. Your settings may differ from the values given in the manual depending upon the temperature settings required.
- After programming Controller, the settings will be automatically saved after 20 seconds of keypad inactivity.
- If the Controller display indicates any error(s), turn to Table R on page 34 to identify and correct the error(s) that are displayed.

**APPROVED
NOTES**