

APPROVED

SUPPLEMENTAL INSTALLATION AND OPERATING INSTRUCTIONS

FlexGas®

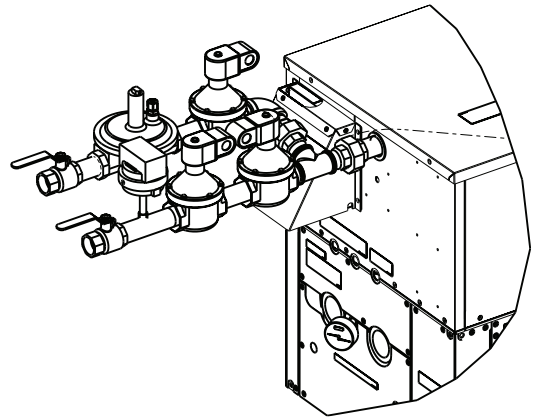

For Hi Delta Models
H 302CD-2342CD
WH 302CD-2342CD
P 992CD-2342CD



IMPORTANT SAFETY INSTRUCTIONS. READ AND FOLLOW ALL INSTRUCTION. SAVE THESE INSTRUCTIONS.

FOR YOUR SAFETY: Do not store or use gasoline or other flammable vapors and liquids or other combustible materials in the vicinity of this or any other appliance. To do so may result in an explosion or fire.

NOTE: THIS MANUAL IS SUPPLEMENTAL FOR THE FLEXGAS MODELS OF THE HI DELTA HEATERS. THIS MANUAL ADDRESSES THE SPECIFIC DIFFERENCES BETWEEN THESE HEATERS AND STANDARD HI DELTA MODELS. Please refer to the standard Installation and Operating Instruction Manuals (241663 and 241664 as appropriate) for installation requirements which are not related to the gas supply.

WHAT TO DO IF YOU SMELL GAS:

- Do not try to light any appliance.
- Do not touch any electrical switch; do not use any phone in your building.
- Immediately call your gas supplier from a neighbor's phone. Follow the gas supplier's instructions.
- If you cannot reach your gas supplier, call the fire department.

Installation and service must be performed by a qualified installer, service agency or the gas supplier.

This manual should be maintained in legible condition and kept adjacent to the variable speed pump or in a safe place for future use.



Effective: 02-26-2021
Replaces: 05-15-2017
P/N 241295 Rev. 6

APPROVED

Revision 6 reflects the following changes:

Model renaming on page 1. First paragraph text revised on page 4. "Bleeds/Vents" paragraph text revised on page 5. Revised Figure 4 on page 6. "Safety Inspection" point 7 text revised on page 8. Updated gas supply pressures from 5.0 to 5.6 and from 8.0 to 11.0.

APPROVED

CONTENTS

Model Identification.....	4	Start up.....	7
Ratings and Certifications	4	FlexGas System Start Up.....	8
Component Locations	5	FlexGas Operation	9
Installation Codes.....	5	Wiring Diagram	10
Gas Supply.....	5	Illustrated Parts List.....	11
Bleed Vents	6		

APPROVED
heater.

⚠ WARNING: Do not use this heater if any part has been under water. Immediately call a qualified service technician to inspect the heater and to replace any part of the control system and any gas control which has been under water.

⚠ WARNING: Should overheating occur or the gas supply valve fail to shut off, do not turn off or disconnect the electrical supply to the heater. Instead, shut off the gas supply at a location external to the heater.

⚠ WARNING: Risk of electrical shock. More than one disconnect switch may be required to de-energize the equipment before servicing.

⚠ WARNING: This FlexGas heater is intended for operation on Natural Gas as the primary fuel. **DO NOT** use this heater on Propane Gas as the primary fuel.

Raypak strongly recommends that this manual be reviewed thoroughly before installing your Hi Delta heater equipped with FlexGas. Raypak also recommends that the appropriate Hi Delta Installation and Operating Instruction manual (241663 for models 302C-902C, or 241664 for models 992C – 2342C) be thoroughly read before attempting to install these heaters. Factory warranty does not apply to heaters that have been improperly installed or operated. (Refer to the warranty at the back of the standard Hi Delta manuals.) Installation and service must be performed by a qualified installer, service agency or gas supplier. If, after reviewing these manuals, you still have questions which these manuals do not answer, please contact the manufacturer or your local Raypak representative.

Thank you for purchasing a Raypak product. We hope you will be satisfied with the high quality and durability of our equipment.

Model Identification

The model identification number and heater serial number are found on the heater rating plate located on the lower right outside jacket of the heater. The model number will have the form H9 1262CD or similar depending on the heater size and configuration. The letter(s) in the first group of characters identifies the application (H = Hydronic Heating, WH = Domestic Hot Water (DHW), P = Pool). The number which follows identifies the firing mode (1 or 4 = on-off, 3 = 2-stage, 8 = 3-stage and 9 = 4-stage).

NOTE: Not all these firing options are available on all heaters. Refer to the Hi Delta manual for available firing options. The second group of characters identifies the size of the heater (four numbers representing the approximate MBTUH input), and, where applicable, a letter, indicating the manufacturing series. The final character is the letter “D” which designates the heater as a FlexGas-equipped

NOTE: Not all these firing options are available on all heaters.

Model	Input (MBTUH)	Pipe Size (Nat)	Pipe Size (LP)
302CD	300	1-1/4"	3/4"
402CD	399	1-1/4"	3/4"
502CD	500	1-1/4"	3/4"
652CD	650	1-1/4"	3/4"
752CD	750	1-1/4"	1-1/4"
902CD	900	1-1/4"	1-1/4"
992CD	990	2"	1-1/4"
1262CD	1260	2"	1-1/4"
1532CD	1530	2"	1-1/4"
1802CD	1800	2"	1-1/4"
2072CD	2070	2"	1-1/4"
2342CD	2340	2"	1-1/4"

Table A. FlexGas Specifications

Ratings and Certifications

Standards

- ANSI Z21.13 · CSA 4.9 - latest edition, Gas-Fired Hot Water Boilers
- CAN 3.1 - latest edition, Industrial and Commercial Gas-Fired Package Boilers
- ANSI Z21.56 · CSA 4.7 - latest edition, Gas-Fired Pool Heaters
- ANSI Z21.10.3 · CSA 4.3 - latest edition, Gas Water Heaters

APPROVED

All Raypak heaters are National Board registered, and design-certified and tested by the Canadian Standards Association (CSA) for the U.S. and Canada. Each heater is constructed in accordance with Section IV of the American Society of Mechanical Engineers (ASME) Pressure Vessel Code, and bears either the ASME "H" stamp for boilers or "HLW" stamp for water heaters and pool heaters. The heater also complies with the latest edition of ASHRAE 90.1 Standard.

⚠ WARNING: Altering any Raypak pressure vessel by installing replacement heat exchangers, tube bundle headers, or any ASME parts not manufactured and/or approved by Raypak will instantly void the ASME and CSA ratings of the vessel and any Raypak warranty on the vessel. Altering the ASME or CSA ratings of the vessel also violates national, state, and local approval codes.

Rated inputs are suitable for up to 4,500 ft (1372 m) elevation without de-rating. Consult the factory for installations at altitudes over 4,500 ft (1372 m) above sea level.

Component Locations

NOTE: Maintain upright orientation of all components as shown in Figure 1.

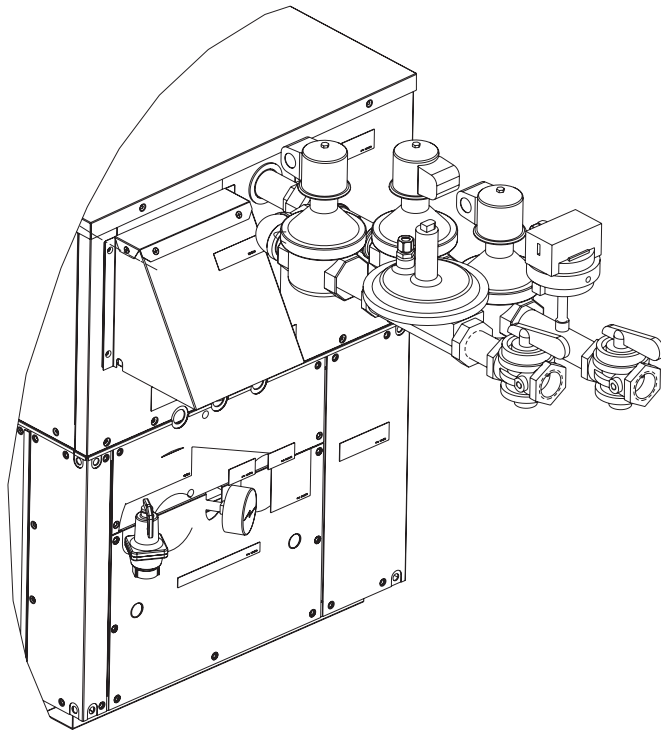

FlexGas cover not shown for clarity

Figure 1. Component Locations – Back

Installation Codes

Installations must follow these codes:

- Local, state, provincial, and national codes, laws, regulations and ordinances
- National Fuel Gas Code, ANSI Z223.1/NFPA 54 – latest edition (NFGC)
- National Electrical Code, ANSI/NFPA 70 - latest edition (NEC)

For Canada only: CAN/CGA B149 Installation Code (B149.1) and CSA C22.1 C.E.C. Part 1 (C22.1)

Gas Supply

This heater will be connected to 2 different gas supplies (Natural Gas and Propane Gas).

Each gas piping must have a separate sediment trap ahead of the gas controls. Pounds-to-inches regulators must be installed to reduce the gas supply pressure to a maximum of 10.5 in. WC for natural gas and 13.0 in. WC for propane gas. The regulator should be placed a minimum distance of 10 times the pipe diameter upstream of the heater gas controls.

⚠ CAUTION: The heater must be disconnected from the gas supply during any pressure testing of the gas supply system at test pressures in excess of 1/2 psi (3.45 kPa).

The heater must be isolated from the gas supply piping system by closing the manual shutoff valves during any pressure testing of the gas supply piping system at test pressures equal to or greater than 1/2 psi (3.45 kPa). Relieve test pressure in the gas supply line prior to reconnecting the heater and its manual shutoff valves to the gas supply lines. **FAILURE TO FOLLOW THIS PROCEDURE MAY DAMAGE THE GAS VALVES.** Over-pressurized gas valves are not covered by warranty. The heater and its gas connections shall be leak-tested before placing the appliance in operation. Use soapy water for leak test. DO NOT use an open flame.

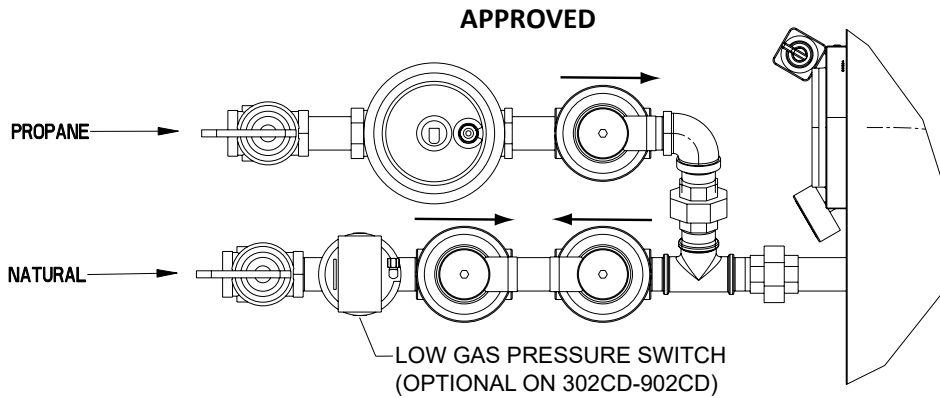

Figure 2. Gas Supply Connection - Top View

Gas Supply Pressure

A minimum of 5.6 in. WC and a maximum of 10.5 in. WC upstream gas pressure is required under load and no-load conditions for natural gas. A minimum of 11.0 in. WC and a maximum of 13.0 in. WC is required for propane gas. The gas pressure regulator(s) supplied on the heater is for low-pressure service. If upstream gas pressures exceed 14.0 in. WC, intermediate gas pressure regulators, of the lockup type, must be installed.

CAUTION: Do not use Teflon tape on gas line pipe thread. A pipe compound rated for use with natural and propane gases is recommended. Apply sparingly only on male pipe ends, leaving the two end threads bare.

CAUTION: Support gas supply piping with hangers, not by the heater or its accessories. Make sure the gas piping is protected from physical damage and freezing, where required.

When connecting additional gas utilization equipment to the gas piping system, the existing piping must be checked to determine if it has adequate capacity for the combined load.

The gas valve pressure regulator(s) on the Hi Delta heater are nominally preset at 3.5 in. WC. The pressure regulator on the FlexGas propane system is nominally set at 2.2 ± 0.1 in. WC. This can be verified by measuring the propane gas pressure at the upper manifold pressure tap shown in **Figure 4**. The pressure at the gas valve(s) outlet tap, measured with a manometer, while in operation should be 3.5 ± 0.1 in. WC for natural gas. A nominal pressure of 1.3 in. WC will be observed at the individual heater gas valve outlet taps on propane gas. See **Figure 4** for gas pressure measurement locations.

CAUTION: Do not adjust the individual heater gas valve pressure settings when firing with propane gas. Propane adjustments (if necessary) should **ONLY** be made to the FlexGas propane regulator.

NOTE: **DO NOT** adjust the FlexGas propane regulator setting without verifying proper operation including the use of a flue gas analyzer.

Bleeds/Vents

This FlexGas gas train is equipped with a propane gas regulator which may need to be vented to the outdoors as required by state and local codes. If the regulator is required to be vented, the cover must be removed and vent lines installed and ran to a suitable location outside the building in compliance with the NFGC. See **Figure 3**.

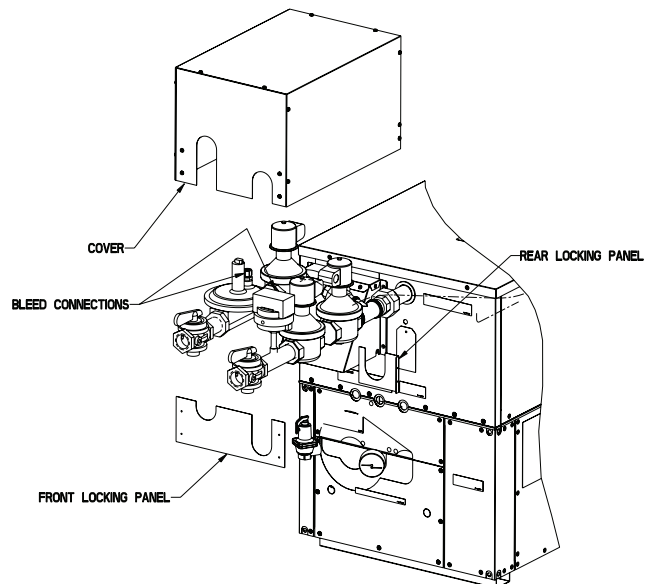

Figure 3. FlexGas Cover Removal & Vent Locations

APPROVED

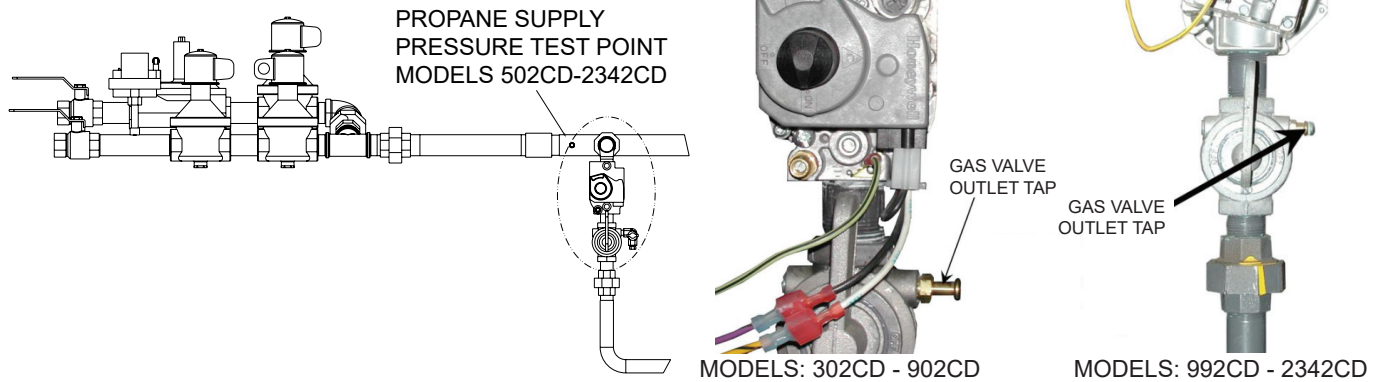

Figure 4. FlexGas Gas Pressure Measurement Locations

Start-Up

For Your Safety

⚠ WARNING: If you do not follow these instructions exactly, a fire or explosion may result causing property damage, personal injury or loss of life.

This appliance has a hot surface igniter(s). It is equipped with an ignition device(s) which automatically lights the burners. Do not try to light the burners by hand.

BEFORE OPERATING, smell all around the appliance area for gas. Be sure to smell near the floor because some gas is heavier than air and will settle on the floor.

WHAT TO DO IF YOU SMELL GAS:

- Do not try to light any appliance.
- Do not touch any electrical switch; do not use any telephone in your building.
- Immediately call your gas supplier from a neighbor's telephone. Follow the gas supplier's instructions.
- If you cannot reach your gas supplier, call the fire department.
- Use only your hand to push in or turn the gas control knob. Never use tools. If the knob will not turn by hand, do not try to repair it, call a qualified service technician. Forced or attempted repair may result in a fire or explosion.
- Do not use this appliance if any part has been under water, immediately call a qualified service technician to inspect the appliance and to replace any part of the control system and any gas control which has been under water.
- Check around unit for debris and remove combustible products, i.e. gasoline, etc.

Pre Start-up Check

1. Verify heater is filled with water.
2. Check system piping for leaks. If found, repair immediately.
3. Vent air from system. Air in system can interfere with water circulation.
4. Purge air from gas lines up to FlexGas gas train.

Initial Start-up

Tools Needed:

- (1) 12-0-12, 24" scale U-tube manometer
- (4) 6-0-6, 12" scale U-tube manometers (min.)
- (1) Screwdriver
- (1) Multi-meter
- (1) 3/16" Allen wrench

NOTE: Digital manometers are not recommended.

APPROVED

FlexGas System Start-up

Preparation

⚠ WARNING: Do not turn on gas at this time.

Check Power Supply

With multi-meter at incoming power in Hi Delta heater, check voltage between:

Hot - Common (≈ 120 VAC)

Hot - Ground (≈ 120 VAC)

Common - Ground (< 1 VAC)

⚠ WARNING: If Common - Ground is > 1 VAC, STOP: Contact electrician to correct ground failure. Failure to do this may burn out 120V-24V transformer, or may cause other safety control damage or failure.

Attach Manometers to Measure Pressures

1. Turn off main gas valves.
2. Attach 24" scale manometer to the first main gas shutoff valve pressure tapping.
3. Attach (1) 12" scale manometer to the outlet side of the second main gas shutoff valve pressure tapping.
4. Attach (1) 12" scale manometer near the fan-proving switch. Pull black cap from air pressure switch tee and connect the manometer. **NOTE:** Retain caps for reinstallation later.

NOTE: The fan(s) pressure is already factory-set to 1.4 in. \pm .1 in. WC (up to 4500 ft [11372 m] altitude). If adjustment(s) is required, consult the appropriate Hi Delta manual.

Check Gas Supply Pressure

1. Slowly turn on main gas shutoff valve.
2. Read the gas supply pressure from the manometer; minimum supply pressure for natural gas is 5.6 in. WC, recommended supply is 7.0 in. WC, minimum supply pressure for propane gas is 11.0 in. WC (dynamic readings, all stages firing).
3. If the pressure is > 14.0 in. WC, turn off the valve.
4. Check if the service regulator is installed and/or adjust the service regulator.

⚠ WARNING: This FlexGas heater is intended for operation on Natural Gas as the primary fuel. DO NOT use this heater with Propane Gas as the primary fuel.

1. Turn off unit. Ensure that the switch on the FlexGas control is in the position marked "NAT". See **Figure 5** for FlexGas control operation. Ensure the manual valve on the natural gas supply is open and the manual valve on the propane supply is closed.
2. Turn on the unit, wait 15 seconds, and the igniter should glow. Look into sight glass located at each end of the heater to check igniter operation. Gas valves should open in 45-60 seconds.
3. If burner does not light on first trial. It will retry, up to three times.
4. Main burner ignition: Check manifold gas pressure at gas valve outlet pressure tap. This should read 3.5 ± 0.1 in. WC for natural gas. If the natural gas manifold pressure is not within 3.5 ± 0.1 in. WC, follow the instructions in the Hi Delta manual for adjusting manifold pressure. If a flue gas analyzer is used, the CO₂ on natural gas should be 7.5-8.5% and CO should be less than 150 ppm.

NOTE: Do not adjust Hi Delta valve(s) or manifold settings when operating on propane. These should only be adjusted while firing natural gas.

5. When acceptable operation on Natural Gas is confirmed, turn the gas selector key on the FlexGas control to "OFF".
6. Close the manual valve on the natural gas supply then open the manual valve on the propane supply. When the heater shuts off, turn the FlexGas control key counter-clockwise to the "PRO" position.
7. Wait 15-seconds, and the igniter should glow. Look into sight glass located at each end of the heater to check igniter operation. Gas valves should open in 45-60 seconds.
8. If burner does not light on first trial. It will retry, up to three times.
9. Main burner ignition: Check upper manifold gas pressure.
10. If the pressure readings differ by more than ± 0.1 in. WC, remove screw cover from the gas pressure regulator on the FlexGas fuel train and adjust until upper manifold pressure is nominally 2.2 ± 0.1 in. WC (manifold pressure 1.3 ± 0.1 in. WC). If a flue gas analyzer is used, the CO₂ on propane should be 9.0-10.0% and CO should be less than 150 ppm.

CAUTION: Once the natural gas pressures are established, DO NOT adjust the Hi Delta gas valves to attain the required propane pressures. Adjustments must be made to the FlexGas propane regulator.

11. Replace the screw cover.

CAUTION: Special manifold and air settings may be required. Verify rating plate and blower housing.

12. Turn the gas selector key on the FlexGas control panel to "OFF".

13. Close the manual valve on the propane gas supply and open the manual valve on the natural gas supply. Turn the gas selector key on the FlexGas control clockwise to "NAT". The heater is now ready for operation.

FlexGas Operation - Changing Fuels

From NAT to PRO:

1. Turn the boiler off (power switch on front control panel).
2. Turn FlexGas key to "OFF".
3. Close NAT manual valve.
4. Open PRO manual valve.
5. Turn FlexGas key to "PRO".
6. Turn the boiler on.

NOTE: Reset Low Gas Pressure Switch (when equipped) if necessary. Refer to Figure 2 for location.

From PRO to NAT:

1. Turn the boiler off (power switch on front control panel).

2. Turn FlexGas key to "OFF".
3. Close PRO manual valve.
4. Open NAT manual valve.
5. Turn FlexGas key to "NAT".
6. Turn the boiler on.

Safety Inspection

1. Check all thermostats and high limit settings.
2. During the following safety checks leave manometers hooked up, check and record.
3. If other gas-fired appliances in the room are on the same gas main, check all pressures on the Hi Delta with all other equipment running.
4. Check thermostats for ON-OFF operation.
5. Check high limits for ON-OFF operation.
6. While in operation, check flow switch operation.
7. Check the low gas pressure switch (if so equipped). (For proper adjustment, use the attached manometers, if available, to set pressure. The scales on the switch are approximate only.) Low gas pressure switch must be set at 5.0 in. WC for natural gas.

Follow-Up

Safety checks must be recorded as performed.

Turn heater on. After main burner ignition:

1. Check manometer for proper reading.
2. Cycle heater several times and re-check readings.
3. Turn unit off.
4. Remove all manometers and replace caps and screws.
5. Replace all gas pressure caps.
6. Check for gas leaks one more time.
7. Restart unit.

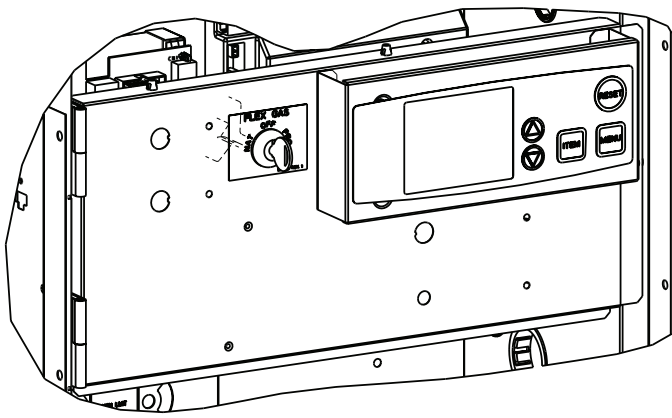

Figure 5. FlexGas Control Panel

Wiring Diagram

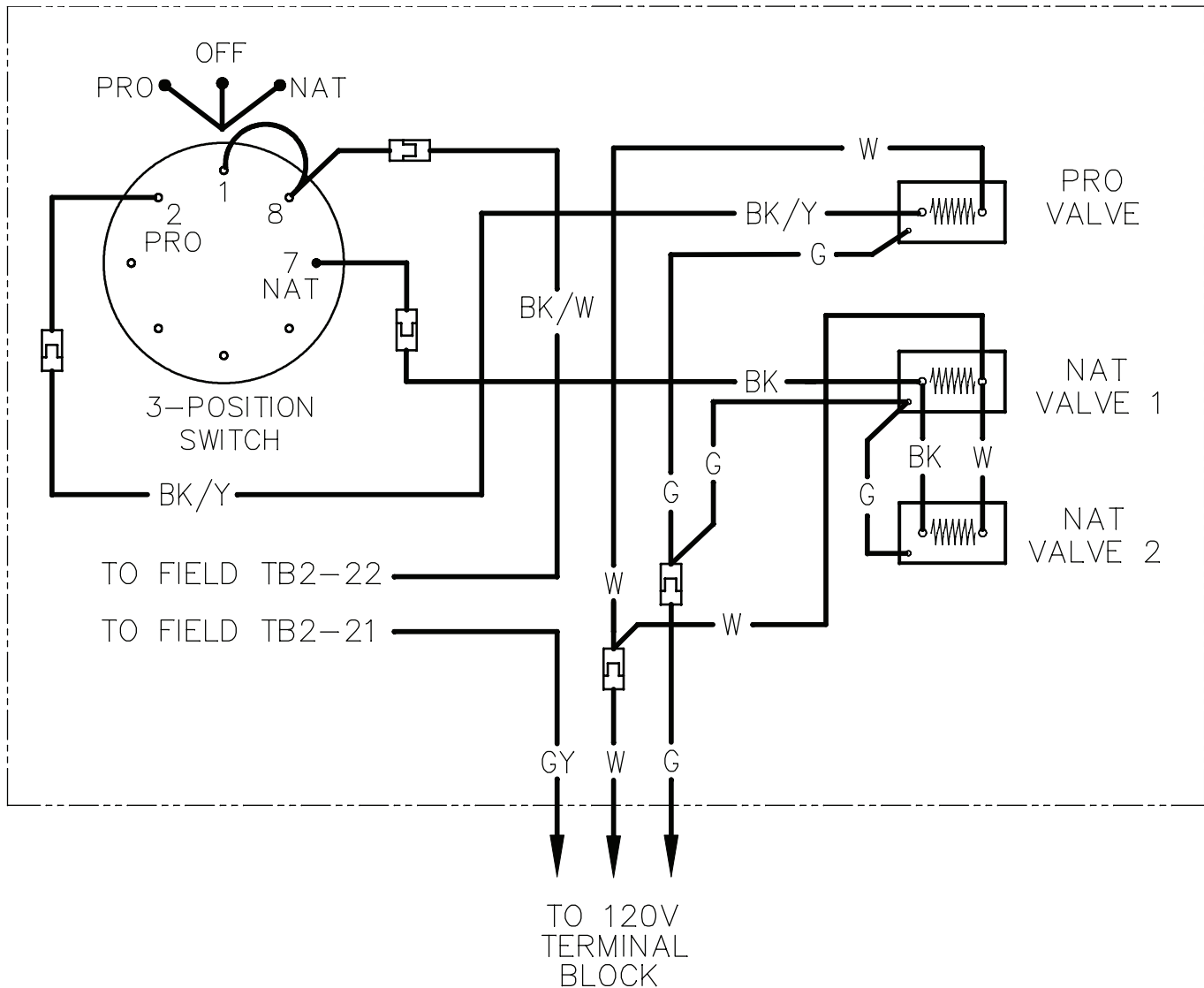
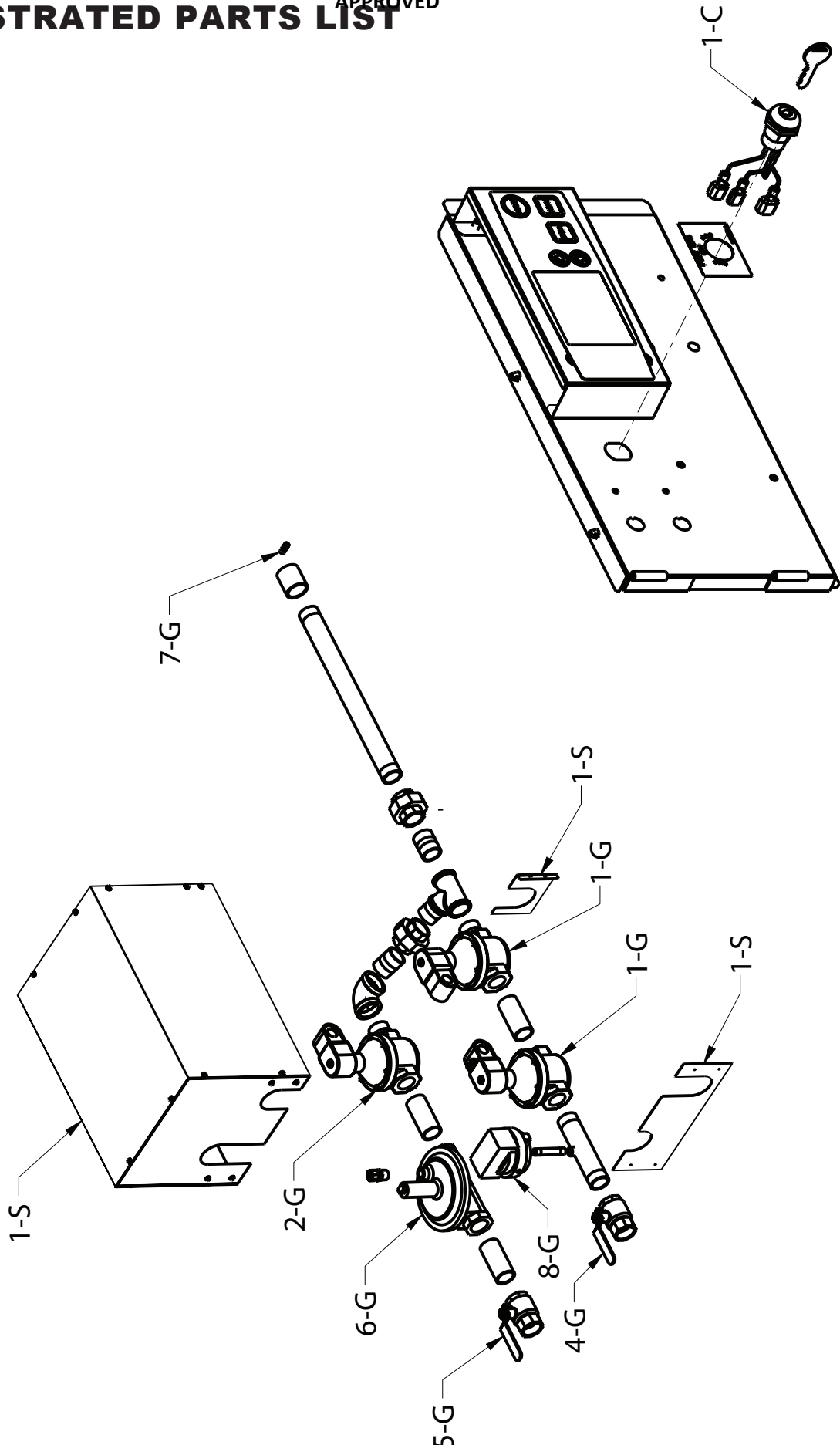

Figure 6. Wiring Diagram
UNCONTROLLED DOCUMENT IF PRINTED

ILLUSTRATED PARTS LIST APPROVED



APPROVED

CALL OUT	DESCRIPTION	302CD-652CD	752CD-902CD	992CD-1262CD	1532CD-2342CD
1-C	KEY SWITCH ASSY DECAL	011943F	011943F	011943F	011943F
1-G	GAS SOLENOID VALVE (NAT)	011910F	011910F	011911F	011911F
2-G	GAS SOLENOID VALVE (PRO)	012125F	011910F	011910F	011910F
4-G	MANUAL GAS VALVE (NAT)	011945F	011945F	007665F	007665F
5-G	MANUAL GAS VALVE (PRO)	011944F	011945F	011945F	011945F
6-G	GAS REGULATOR VALVE	011946F	011947F	011947F	011948F
7-G	BLEEDLE VALVE	007423F	007423F	007423F	007423F
8-G	LOW GAS PRESSURE SWITCH	007187F	007187F	007187F	007187F
1-S	GAS TRAIN COVER	011949F	011949F	011950F	011950F

APPROVED

