

Job: _____
 Engineer: _____
 Contractor: _____
 Prepared By: _____ Date: _____
 Model: _____ Indoor/Outdoor: _____ MBTUH Input: _____

Hi Delta[®] - Type H

Space Heating/Hot Water Boilers

Models 992B-2342B

- ◆ **100% Factory Fire Tested**
- ◆ **Efficiency: 84%**
- ◆ **Maximum Outlet Temperature: 230°F**
- ◆ **Minimum Non-Condensing Inlet Temperature: 105°F**
- ◆ **Thermal Shock Proof Heat Exchanger**
- ◆ **Limited Twenty-Year Thermal Shock Warranty**
- ◆ **Limited Ten-Year Closed-System Heat Exchanger Warranty**
- ◆ **Full Safety Diagnostics with Fault History**
- ◆ **PolyTuf Powder Coated Cabinet**
- ◆ **No Combustible Floor Shield Required**
- ◆ **Fan-Assisted**
- ◆ **Patented Burner Security Blanket**

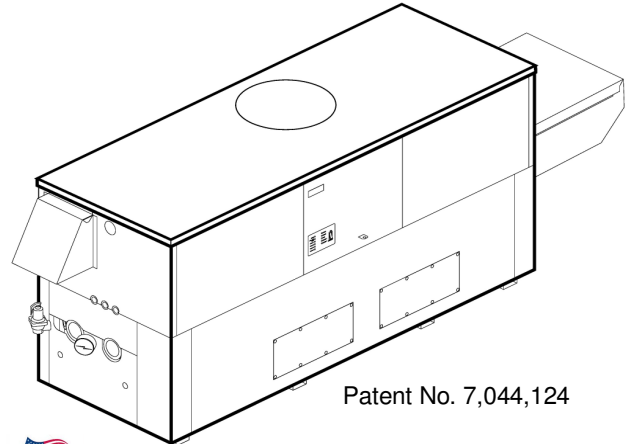

Patent No. 7,044,124



Proudly Assembled in the USA

Heat Exchanger

- H Stamp
- Headers
 - Glass-Lined Cast Iron – Standard
 - Brass – Option A-1
- ASME Inspected and Stamped 160 PSIG Working Pressure
- National Board Approved
- Fin Tubing
 - Copper – Standard
 - Cupro Nickel – Option A-3
- ASME Steel Tube Sheet
- Silicone High Temp. O-Rings
- ASME Pressure Relief Valve
 - 60 PSIG – Standard
 - _____ PSIG – Optional
- Temperature and Pressure Gauge
- Water Connections
 - Left – Standard
 - Right – Option A-6

Controls

- 120V, 60Hz, 1Ø Power Supply
- 120/24V 60Hz Transformer
- 100% Shut-Off/Lockout
- Hot Surface Ignition
- Remote Flame Sensor
- High Limit Control, Manual Reset
- On/Off Power Switch
- Manual Shut-Off, Front-Mounted
- Flow Switch
- Blocked Vent Pressure Switch
- Combustion Air Proving Switches
- Economaster Pump Time Delay
- Enable/Disable
- Diagnostics Panel with LCD Display, 2 Lines 20 Characters

Gas Train

- Manual Gas Shut-Off Valve(s)
- Combo Valve(s)
- Low Gas Pressure Switch, Manual
- Firing Mode
 - 3-Stage (H8): Model 992B
 - 4-Stage (H9): Models 1262B-2342B
- Fuel
 - Natural Gas
 - Propane Gas
 - 4" WC Gas Supply Pressure G-20
- Design Certified ANSI Z21.13/ CSA 4.9

Construction

- Indoor/Outdoor Construction
- Enclosed Front Controls
- CSA Low Lead Certified ($\leq .25\%$ Lead)

Venting

- Vent Location
 - Top – Standard
 - Rear – Option D-14
- Vent Termination Cap
 - Outdoor D-11
 - Indoor, Horizontal D-15
 - Indoor, Vertical (by others)
- Combustion Air
 - In-Line Filter Kit (TruSeal only) D-17
 - Air Intake Elbow D-16
- Extractor – Optional
 - By others
 - Not required

Burner

- Ultra-Low NOx: Less than 20 PPM

Temperature Controls

- B-__ TempTracker Digital Controller, 2-Stage
- B-__ TempTracker Digital Controller, 4-Stage
- B-__ TempTracker Mod+ Hybrid (2-16 Boilers)
- B-60 Stage Interface

Options

- C-6 Ignition Module, Manual Reset
- D-21 TruSeal[®] Direct Vent
- F-10 Low Water Cut-Off, Remote Probe
- I-1 High Limit Control, Auto Reset
- P-__ Pump: _____ HP, 120V, 1Ø, 60Hz
 - Cast Iron Bronze
 - Mounted Loose
 - Front Rear
- P-__ Cold Water Start (See 2000.49)
- S-2 High Gas Pressure Switch, Manual
- X-1 SureRack[™] Kit
- X-2 SureRack Add-on

Regulatory Agency Requirements



Raypak[®]

A Rheem[®] Company

Hi Delta – Type H Models 992B-2342B

Model _____

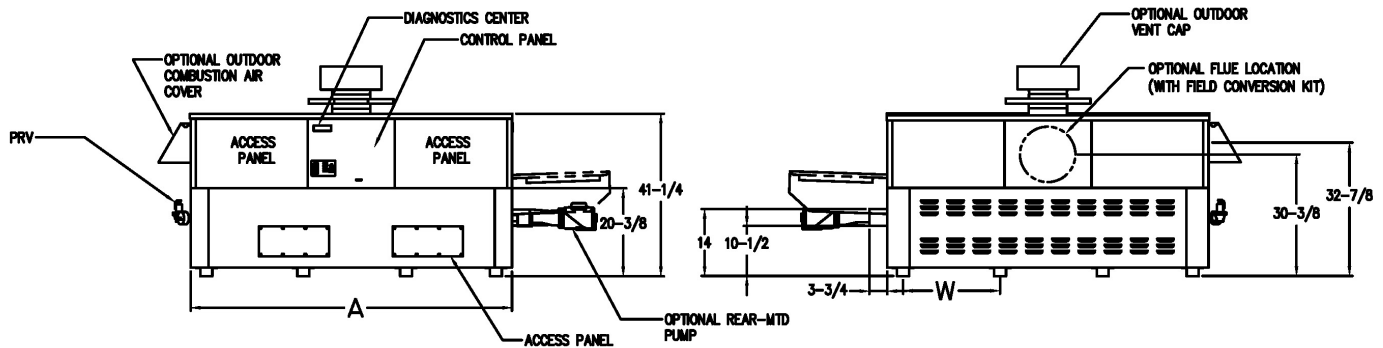

FRONT VIEW

BACK VIEW

NOTE: Pump location varies based on model and application

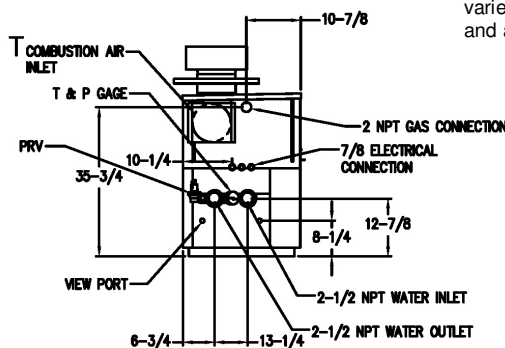

LEFT SIDE

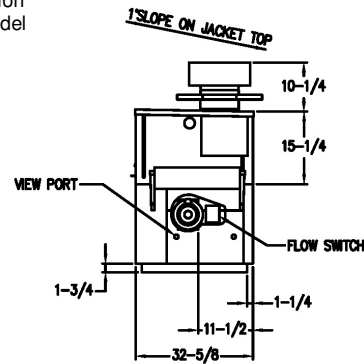

RIGHT SIDE

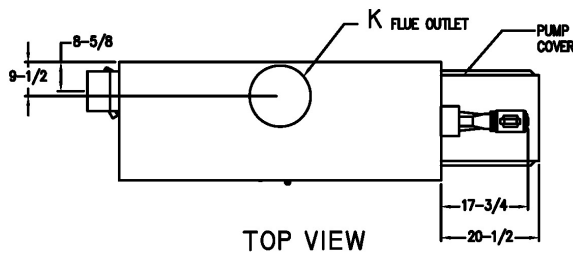

TOP VIEW

RATES OF FLOW AND PRESSURE DROPS

Model	20°F ΔT		30°F ΔT		Min. Flow			Max. Flow		
	GPM	ΔP (ft)	GPM	ΔP (ft)	GPM	ΔP (ft)	ΔT	GPM	ΔP (ft)	ΔT
992B	84	5.6	56	2.5	42	1.5	40	132	14.0	13
1262B	107	10.0	71	4.5	53	2.6	40	132	15.5	16
1532B	130	16.0	86	7.1	65	4.1	40	132	16.5	20
1802B	N/A	N/A	102	10.8	76	6.0	40	132	18.0	23
2002B	N/A	N/A	113	14.0	85	8.1	40	132	19.5	26
2072B	N/A	N/A	117	15.0	88	8.7	40	132	19.5	27
2342B	N/A	N/A	132	21.0	99	12.0	40	132	21.0	30

Basis is 30 GPM or 40°F ΔT for minimum flow, 132 GPM for maximum flow.

SPECIFICATIONS

Model	MBTUH		Firing Stages	A Width	H NPT	K	T	W	Amp. Draw*	Approx. Shipping Wt. (Lbs.)
	Input	Output								
992B	990	832	3	57-1/8	2-1/2	10	10	16-13/16	<12	900
1262B	1260	1058	4	68-1/2	2-1/2	12	10	20-9/16	<12	1010
1532B	1530	1285	4	79-7/8	2-1/2	12	10	24-3/8	<12	1225
1802B	1800	1512	4	91-1/8	2-1/2	14	10	28-1/8	<12	1350
2002B	1999	1679	4	102-1/2	2-1/2	14	10	31-15/16	<12	1450
2072B	2070	1739	4	102-1/2	2-1/2	14	10	31-15/16	<12	1450
2342B	2340	1966	4	113-7/8	2-1/2	16	10	35-11/16	<12	1520

Dimensions are in inches.

* Without pump

NOTES: 1. Rates shown are for natural or propane gas, and elevations up to 4,500 feet. For installation above 4,500 feet, please contact manufacturer.
2. Required natural gas pressure is 7 – 10.5" WC. Required propane gas pressure is 11 - 13" WC.

Raypak, Inc. ▪ 2151 Eastman Avenue, Oxnard, CA 93030 ▪ (805) 278-5300 ▪ Fax (800) 872-9725 ▪ www.raypak.com