

INSTALLATION & OPERATING INSTRUCTIONS

XFyre[™]
NINETY PLUS



**Models 300-850
Types H & WH**



WARNING: Improper installation, adjustment, alteration, service or maintenance can cause property damage, personal injury, exposure to hazardous materials* or loss of life. Review the information in this manual carefully. *This unit contains materials that have been identified as carcinogenic, or possibly carcinogenic, to humans.

FOR YOUR SAFETY: Do not store or use gasoline or other flammable vapors and liquids or other combustible materials in the vicinity of this or any other appliance. To do so may result in an explosion or fire.

WHAT TO DO IF YOU SMELL GAS:

- Do not try to light any appliance.
- Do not touch any electrical switch; do not use any phone in your building.
- Immediately call your gas supplier from a neighbor's phone. Follow the gas supplier's instructions.
- If you cannot reach your gas supplier, call the fire department.

Installation and service must be performed by a qualified installer, service agency or the gas supplier.

This manual should be maintained in legible condition and kept adjacent to the heater or in a safe place for future reference.

Raypak[®]
A Rheem[®] Company

Rev. 3 includes the following:

Changes to: Table I on page 16, Fig. 35 on page 42, Table S on page 43

Additions: None

Deletions: None

CONTENTS

WARNINGS	4	WIRING DIAGRAM	40
Pay Attention to These Terms	4	START-UP	41
BEFORE INSTALLATION	5	Pre Start-up	41
Product Receipt	5	Pre Start-up Check	41
Model Identification	5	Initial Start-up	41
Ratings and Certifications	5	Preparation	42
Installations at Elevation	5	Start-Up	42
Component Locations	6	OPERATION	44
General Information	6	Lighting Instructions	44
Time/Temperature Relationships		To Turn Off Gas to Appliance	45
in Scalds	7	XFyre Error Codes	45
GENERAL SAFETY	7	Heater Errors	45
INSTALLATION	8	Heater Faults	45
Installation Codes	8	TROUBLESHOOTING	45
Equipment Base	8	XFyre Fault Text	46
Clearances	8	Sensor Resistance Values	48
Combustion and Ventilation Air	9	MAINTENANCE	49
Conventional Combustion Air Supply	11	Suggested Minimum	
Water Piping	12	Maintenance Schedule	49
Hydronic Heating	13	Preventive Maintenance	
Gas Supply	16	Schedule	49
Electrical Power Connections	17	APPENDIX	52
Field Wiring Connection	19	Inside Air Contamination	52
Venting	23	Important Instructions for the	
Venting Installation Tips	25	Commonwealth of Massachusetts	53
Venting Configurations	26	WARRANTY	54
Outdoor Installation	31	START-UP CHECKLIST	55
Controls	32		
Operating Instructions	35		

WARNINGS

Pay Attention to These Terms

DANGER:	Indicates the presence of immediate hazards which will cause severe personal injury, death or substantial property damage if ignored.
WARNING:	Indicates the presence of hazards or unsafe practices which could cause severe personal injury, death or substantial property damage if ignored.
CAUTION:	Indicates the presence of hazards or unsafe practices which could cause minor personal injury or product or property damage if ignored.
NOTE:	Indicates special instructions on installation, operation, or maintenance which are important but not related to personal injury hazards.

DANGER: Make sure the gas on which the boiler will operate is the same type as that specified on the boiler rating plate.

WARNING: Should overheating occur or the gas supply valve fail to shut, do not turn off or disconnect the electrical supply to the boiler. Instead, shut off the gas supply at a location external to the boiler.

WARNING: Do not use this boiler if any part has been under water. Immediately call a qualified service technician to inspect the boiler and to replace any part of the control system and any gas control which has been under water.

WARNING: To minimize the possibility of improper operation, serious personal injury, fire, or damage to the boiler:

- Always keep the area around the boiler free of combustible materials, gasoline, and other flammable liquids and vapors.
- Boiler should never be covered or have any blockage to the flow of fresh air to the boiler.

WARNING: Risk of electrical shock. More than one disconnect switch may be required to de-energize the equipment before servicing.

WARNING - CALIFORNIA PROPOSITION 65: This product contains chemicals known to the State of California to cause cancer, birth defects or other reproductive harm.

CAUTION: If this boiler is to be installed above radiation level, it must be provided with a low water cut-off device at the time of boiler installation.

CAUTION: This boiler requires forced water circulation when the burner is operating. See minimum and maximum flow rates. Severe damage will occur if the boiler is operated without proper water flow circulation.

CAUTION: If this boiler is to be installed in a negative or positive pressure equipment room, there are special installation requirements. Consult factory for details.

NOTE: Minimum 18 AWG, 105°C, stranded wire must be used for all low voltage (less than 30 volts) external connections to the unit. Solid conductors should not be used because they can cause excessive tension on contact points. Install conduit as appropriate. All high voltage wires must be the same size (105°C, stranded wire) as the ones on the unit or larger.

BEFORE INSTALLATION

Raypak strongly recommends that this manual be reviewed thoroughly before installing your XFyre heater. Please review the General Safety information before installing the heater. Factory warranty does not apply to heaters that have been improperly installed or operated. (Refer to the warranty at the back of this manual.) Installation and service must be performed by a qualified installer, service agency or gas supplier. If, after reviewing this manual, you still have questions which this manual does not answer, please contact your local Raypak representative or visit our website at www.raypak.com.

Thank you for purchasing a Raypak product. We hope you will be satisfied with the high quality and durability of our equipment.

Product Receipt

WARNING: Pump motors should NOT be supported by any type of stand or support from above due to possible misalignment of pump and motor which may occur.

On receipt of your heater it is suggested that you visually check for external damage to the shipping crate. If the crate is damaged, make a note to that effect on the Bill of Lading when signing for the shipment. Next, remove the heater from the shipping packaging. Report any damage to the carrier immediately.

On occasion, items are shipped loose. Be sure that you receive the correct number of packages as indicated on the Bill of Lading.

Claims for shortages and damages must be filed with the carrier by consignee. Permission to return goods must be received from the factory prior to shipping. Goods returned to the factory without an authorized Returned Goods Receipt number will not be accepted. All returned goods are subject to a restocking charge.

When ordering parts, you must specify the model and serial number of the heater. When ordering under warranty conditions, you must also specify the date of installation.

Purchased parts are subject to replacement only under the manufacturer's warranty. Debits for defective replacement parts will not be accepted. Parts will be replaced in kind only per Raypak's standard warranties.

Model Identification

The model identification number and heater serial number are found on the heater rating plate located on the upper rear jacket panel of the heater. The model number will have the form H7-850 or similar depending on the heater size and configuration. The letter(s) in the first group of characters identifies the application (H = Hydronic Heating, WH = Domestic Hot Water). The number which follows identifies the firing mode (7 = electronic modulation). The second group of characters identifies the size of the heater (three numbers representing the approximate MBTUH input), and, where applicable, a letter, indicating the manufacturing series.

Ratings and Certifications

Standards:

- ANSI Z21.13 · CSA 4.9 - latest edition, Gas-Fired Hot Water Boilers
- ANSI Z21.10.3 · CSA 4.3 - latest edition, Gas Water Heaters
- CAN 3.1 - latest edition, Industrial and Commercial Gas-Fired Package Boilers
- SCAQMD Rule 1146.2
- CSA verified compliance with California AB1953 and Vermont Legislative Act 193 requirements.

All Raypak heaters are National Board Registered, and design-certified and tested by the Canadian Standards Association (CSA) for the U.S. and Canada. Each heater is constructed in accordance with Section IV of the American Society of Mechanical Engineers (ASME) Boiler and Pressure Vessel Code and bears the ASME "H" stamp. This heater also complies with the latest edition of the ASHRAE 90.1 Standard.

WARNING: Altering any Raypak pressure vessel by installing replacement heat exchangers or any ASME parts not manufactured and/or approved by Raypak will instantly void the ASME and CSA ratings of the vessel and any Raypak warranty on the vessel. Altering the ASME or CSA ratings of the vessel also violates national, state, and local approval codes.

Installations at Elevation

Rated inputs are suitable for up to 2000 ft elevation without de-rating. Consult your local representative or the factory for installations at altitudes over 2000 ft above sea level. No hardware changes are required to the heaters for installations up to 10,000 ft (adjustments may be required).

Component Locations

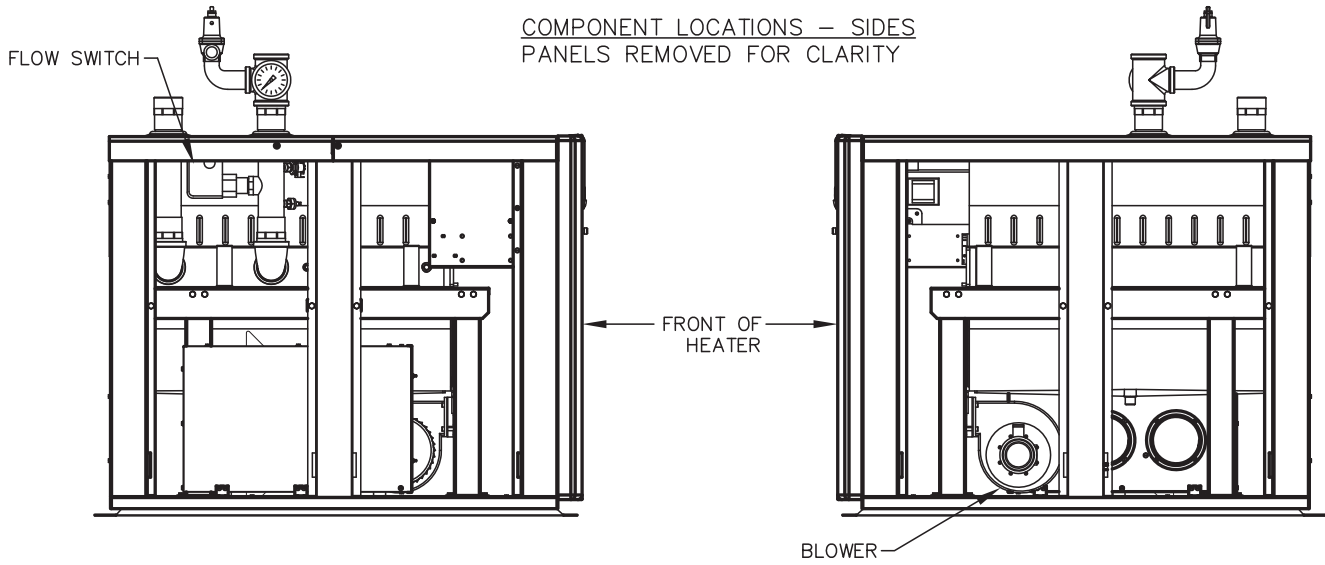

Model 300 shown. Component locations may vary slightly in larger models.

Fig. 1: Component Locations — Sides

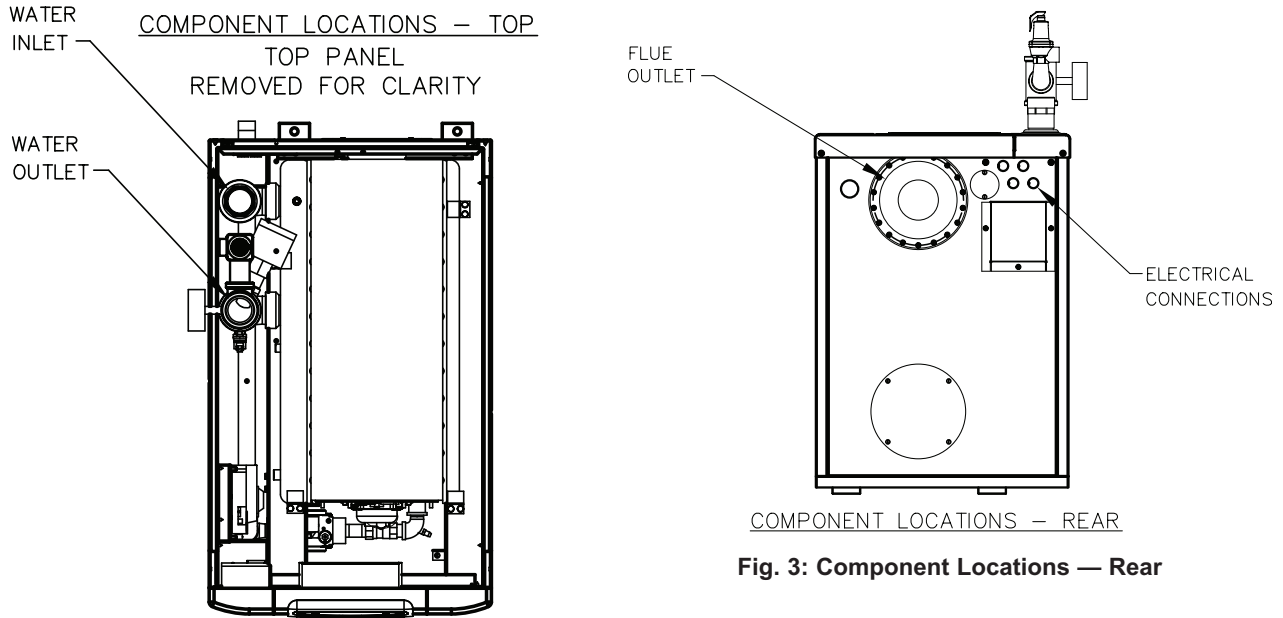

Fig. 2: Component Locations — Top

Fig. 3: Component Locations — Rear

General Information

Model No.	MBTUH Input		Water conn. (NPT)	Gas conn. (NPT)		Vent Size (inches)	
	Max.	Min.		N	P	Flue	Intake
300	300	60	1-1/2"	3/4"	3/4"	4	4
400	399	80	2"	1"	1"	4	4
500	500	100	2"	1"	1"	4	4
700	700	140	2"	1-1/4"	1-1/4"	6	6
850	850	170	2"	1-1/4"	1-1/4"	6	6

Table A: Basic Data

Model No.	Heater Water Volume (gallons)
300	2.9
400	3.6
500	4.2
700	5.0
850	5.8

Table B: Heater Water Volume

GENERAL SAFETY

To meet commercial hot water use needs, the high limit safety control on this water heater will shut off the main gas valve before the outlet temperature reaches 210°F. However, water temperatures over 125°F can cause instant severe burns or death from scalds. When supplying general purpose hot water, the recommended initial setting for the temperature control is 125°F.

Safety and energy conservation are factors to be considered when setting the water temperature on the thermostat. The most energy-efficient operation will result when the temperature setting is the lowest that satisfies the needs of the application.

Water temperature over 125°F can cause instant severe burns or death from scalds. Children, disabled and elderly are at highest risk of being scalded.

- Feel water before bathing or showering.
- Temperature limiting valves are available.

NOTE: When this heater is supplying general purpose hot water for use by individuals, a thermostatically controlled mixing valve for reducing point of use water temperature is recommended to reduce the risk of scald injury. Contact a licensed plumber or the local plumbing authority for further information.

Maximum water temperatures occur just after the heater's burner has shut off. To determine the water temperature being delivered, turn on a hot water faucet and place a thermometer in the hot water stream and read the thermometer.

CAUTION: Hotter water increases the risk of scalding! There is a hot water scald potential if the thermostat is set too high.

DANGER

Water temperature over 125°F can cause instant severe burns or death from scalds.

Children, disabled, and elderly are at highest risk of being scalded.

See instruction manual before setting temperature at water heater.

Feel water before bathing or showering.

Temperature limiting valves are available, see manual.

Time/Temperature Relationships in Scalds

The following chart details the relationship of water temperature and time with regard to scald injury and may be used as a guide in determining the safest water temperature for your applications.

Water Temp.	Time to Produce Serious Burn
120°F	More than 5 minutes
125°F	1-1/2 to 2 minutes
130°F	About 30 seconds
135°F	About 10 seconds
140°F	Less than 5 seconds
145°F	Less than 3 seconds
150°F	About 1-1/2 seconds
155°F	About 1 second

Table courtesy of The Shriners Burn Institute

Table C: Time to Produce Serious Burn

INSTALLATION

Installation Codes

Installations must follow these codes:

- Local, state, provincial, and national codes, laws, regulations and ordinances
- National Fuel Gas Code, ANSI Z223.1/NFPA 54 – latest edition (NFGC)
- National Electrical Code, ANSI/NFPA 70 - latest edition (NEC)
- Standard for Controls and Safety Devices for Automatically Fired Boilers, ANSI/ASME CSD-1, (CSD-1) when required
- For Canada only: CAN/CSA B149 Natural Gas and Propane Installation Code and CSA C22.1 C.E.C. Part 1 (C22.1)

Equipment Base

The heater must be mounted on a level, structurally sound surface. The heater is approved for installation on a combustible surface but must NEVER be installed on carpeting. Gas-fueled equipment installed in enclosed parking garages must be located at least 18 in. above the floor.

CAUTION: The boiler must be level to allow condensate to drain properly from the heat exchanger.

CAUTION: This boiler should be located in an area where water leakage will not result in damage to the area adjacent to the appliances or to the structure. When such locations cannot be avoided, it is recommended that a suitable catch pan, adequately drained, be installed under the appliance. The pan must not restrict air flow.

In addition, the heater shall be installed such that the gas ignition system components are protected from water (dripping, spraying, rain, etc.) during appliance operation or service (circulator replacement, control replacement, etc.).

If the heater needs to be secured to the ground, use the holes in the anchoring legs on the heater.

Clearances

Indoor Installations

Heater Side	Min. Clearances from Combustible Surfaces	Minimum Service Clearances
Floor*	0"	0"
Rear	24"	24"
Right Side	0"	0"
Left Side	0"	0"
Top	12"	24"
Front	Open	24"
Vent	1"	1"

*DO NOT install on carpeting.

Table D: Clearances — Indoor Installations

When installed according to the listed minimum clearances from combustible construction, these heaters can be serviced without removing permanent structural construction around the heater. However, for ease of servicing, we recommend a clearance of at least 24 in. in front, at least 24 in. on the rear and 24 in. above the top of the heater. This will allow the heater to be serviced in its installed location without movement or removal of the heater.

Service clearances less than the minimum may require removal of the heater to service either the heat exchanger or the burner components. In either case, the heater must be installed in a manner that will enable the heater to be serviced without removing any structure around the heater.

Outdoor Installations

These heaters are design-certified for outdoor installation. Heaters must not be installed under an overhang unless clearances are in accordance with local installation codes and the requirements of the gas supplier. Three sides must be open in the area under the overhang. Roof water drainage must be diverted away from heaters installed under overhangs.

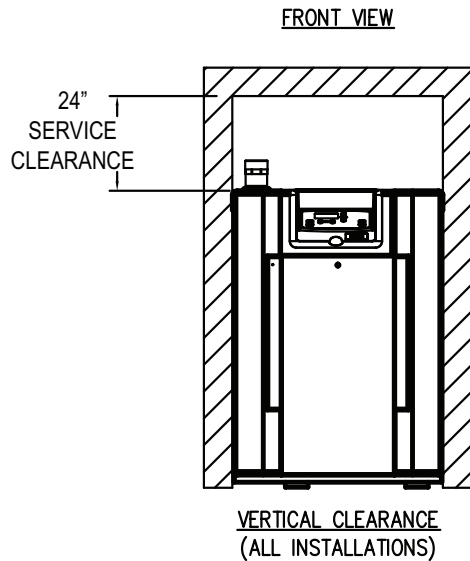
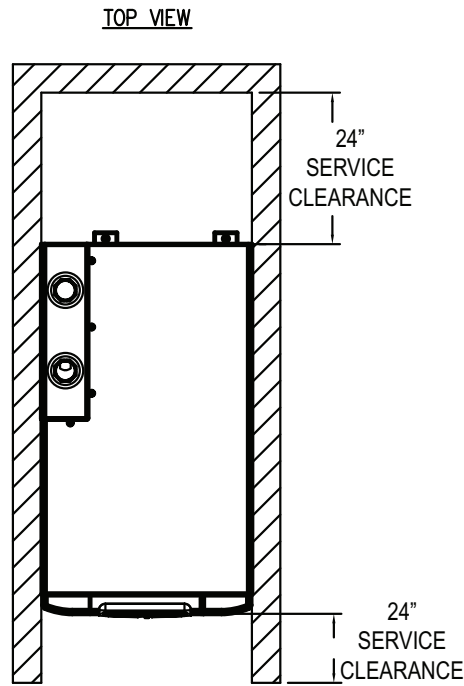

Venting not shown for clarity. Heater must be vented per instructions in this manual

Fig. 4: Minimum Clearances from Combustible Surfaces — Indoor and Outdoor Installations

Heater Side	Min. Clearances from Combustible Surfaces	Minimum Service Clearances
Rear	24"	24"
Right Side	0"	0"
Left Side	0"	0"
Top	Unobstructed	24"
Front	Open	24"
Vent Termination	12"	12"

Table E: Clearances — Outdoor Installations

Combustion and Ventilation Air

NOTE: Use of this boiler in construction areas where fine particulate matter, such as concrete or dry-wall dust, is present may result in damage to the boiler that is not covered by the warranty. If operated in a construction environment, a clean source of combustion air must be provided directly to the boiler.

Indoor Units

This heater must be supplied with sufficient quantities of non-contaminated air to support proper combustion and equipment ventilation. Combustion air can be supplied via conventional means where combustion air is drawn from the area immediately surrounding the heater, or via direct vent, where combustion air is drawn directly from outside. All installations must comply with the requirements of the NFGC (U.S.) and B149 (Canada), and all local codes.

CAUTION: Combustion air must not be contaminated by corrosive chemical fumes which can damage the boiler and void the warranty. (See the Appendix.)

NOTE: It is recommended that the intake vent be insulated in cold climates to minimize sweating.

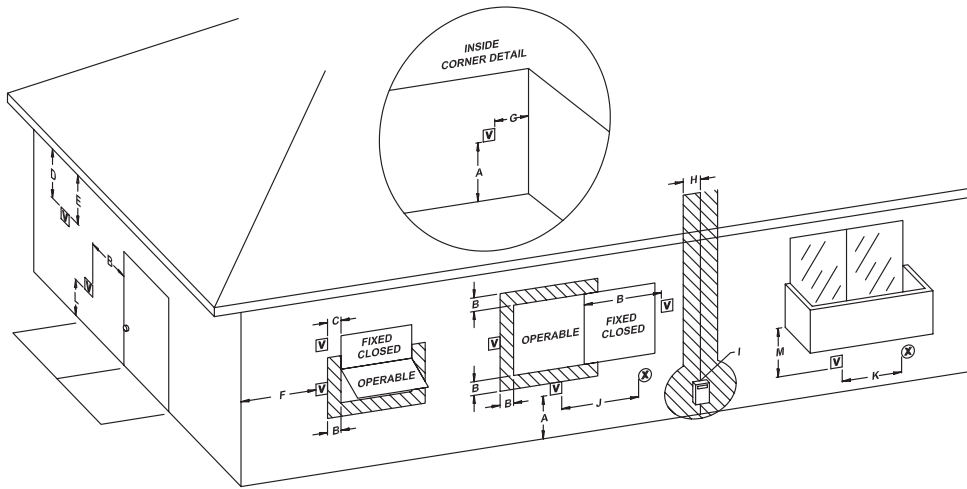

Fig. 5: Minimum Clearances from Vent/Air Inlet Terminations – Indoor and Outdoor Installations

		U.S. Installations ¹	Canadian Installations ²
A	Clearance above grade, veranda, porch, deck, or balcony	1 ft (30 cm)	1 ft (30 cm)
B	Clearance to window or door that may be opened	4 ft (1.2m) below or to side of opening; 1 foot (30 cm) above opening	3 ft (91 cm)
C	Clearance to permanently closed window	*	*
D	Vertical clearance to ventilated soffit located above the terminal within a horizontal distance of 2 ft (61cm) from the centerline of the terminal	5 ft (1.5m)	*
E	Clearance to unventilated soffit	*	*
F	Clearance to outside corner	*	*
G	Clearance to inside corner	6 ft (1.83m)	*
H	Clearance to each side of center line extended above meter/regulator assembly	*	3 ft (91 cm) within a height 15 ft above the meter/regulator assembly
I	Clearance to service regulator vent outlet	*	6 ft (1.83m)
J	Clearance to non-mechanical air supply inlet to building or the combustion air inlet to any other appliance	4 ft (1.2m) below or to side of opening; 1 ft (30 cm) above opening	3 ft (91 cm)
K	Clearance to mechanical air supply inlet	3 ft (91 cm) above if within 10 ft (3m) horizontally	6 ft (1.83m)
L	Clearance above paved sidewalk or paved driveway located on public property	7 ft (2.13m)	7 ft (2.13m) ^t
M	Clearance under veranda, porch, deck or balcony	*	12 in. (30 cm) ^{TT}

¹ In accordance with the current ANSI Z223.1/NFPA 54 National Fuel Gas Code

² In accordance with the current CAN/CGA-B149 Installation Codes

^t Vent terminal shall not terminate directly above sidewalk or paved driveway located between 2 single family dwellings that serves both dwellings

^{TT} Permitted only if veranda, porch, deck, or balcony is fully open on a minimum of two sides beneath the floor and top of terminal and underside of veranda, porch, deck or balcony is greater than 1 ft (30cm)

* Clearances in accordance with local installation codes and the requirements of the gas supplier

Table F: Vent/Air Inlet Termination Clearances

Combustion Air Filter

This heater is supplied with an integral combustion air filter. This filter will reduce the amount of particulates that pass through the combustion system and heat exchanger but will not protect against chemical inside air contamination (See Appendix). The filter must be checked periodically to verify that adequate combustion air is being supplied to the heater. See the Maintenance section of this manual for information on checking the filter and establishing service intervals.

Direct Vent

If outside air is drawn through the intake pipe directly to the unit for combustion:

1. Install the combustion air ducting kit.
2. Install combustion air direct vent in accordance with Fig. 23 (horizontal) or Fig. 24 (vertical) of this manual.
3. Provide adequate ventilation of the space occupied by the heater(s) by an opening(s) for ventilation air at the highest practical point communicating with the outdoors. The total cross-sectional area shall be at least 1 in.² of free area per 20,000 BTUH (111 mm² per kW) of total input rating of all equipment in the room when the opening is communicating directly with the outdoors or through vertical duct(s). The total cross-sectional area shall be at least 1 in.² of free area per 10,000 BTUH (222 mm² per kW) of total input rating of all equipment in the room when the opening is communicating with the outdoors through horizontal duct(s).
4. In cold climates, and to mitigate potential freeze-up, Raypak highly recommends the installation of a motorized sealed damper on the air intake to prevent the circulation of cold air through the heater during the non-operating hours.

TruSeal™ Combustion Air

In addition to the 4 previous steps, combustion air may be ducted directly to the heater by using PVC, CPVC or sealed single-wall galvanized ducting. The duct will attach directly to the air collar located on the rear of the heater when the combustion air ducting kit is installed, using three or four sheet metal screws (not supplied) equally positioned around the circumference of the duct. The screws and duct connection point must be sealed with RTV (not supplied). TruSeal is generally used when damaging contaminants are present in the

mechanical room. All ducting must be self-supported.

CAUTION: Use TruSeal combustion air if damaging airborne contaminants are or may be present in the boiler area. See the Appendix of this manual regarding air contamination.

Conventional Combustion Air Supply

U.S. Installations

All Air from Inside the Building

The confined space shall be provided with **TWO** permanent openings communicating directly with an additional room(s) of sufficient volume so that the combined volume of all spaces meets the criteria for a room large in comparison (NFGC). The total input of all gas utilization equipment installed in the combined space shall be considered in making this determination. **Each opening** shall have a minimum free area of 1 in.² per 1,000 BTUH (2,225 mm² per kW) of the total input rating of all gas utilization equipment in the confined space, but not less than 100 in.² (645 cm²). One opening shall commence within 12 in. (305 mm) of the top, and one opening shall commence within 12 in. (305 mm) of the bottom of the enclosure. The minimum dimension of air openings shall be not less than 3 in. (76 mm) in any direction.

All Air from Outdoors

The confined space shall communicate with the outdoors in accordance with one of the methods below. The minimum dimension of air openings shall not be less than 3 in. (76 mm) in any direction. Where ducts are used, they shall be of the same cross-sectional area as the net free area of the openings to which they connect.

1. **Two permanent openings**, one commencing within 12 in. (305 mm) of the top, and one commencing within 12 in. (305 mm) of the bottom of the enclosure, shall be provided. The openings shall communicate directly, or by ducts, with the outdoors or spaces (crawl or attic) that freely communicate with the outdoors.
 - a. Where directly communicating with the outdoors or where communicating to the outdoors through vertical ducts, **each opening** shall have a minimum free area of 1 in.² per 4,000 BTUH (550 mm² per kW) of total input rating of all equipment in the enclosure.

- b. Where communicating with the outdoors through horizontal ducts, each opening shall have a minimum free area of 1 in.² per 2,000 BTUH (1,100 mm² per kW) of total input rating of all equipment in the enclosure.
2. **One permanent opening**, commencing within 12 in. (305 mm) of the top of the enclosure, shall be permitted where the equipment has clearances of at least 1 in. (25 mm) from the sides and back and 6 in. (152 mm) from the front of the appliance. The opening shall directly communicate with the outdoors or shall communicate through a vertical or horizontal duct to the outdoors or spaces that freely communicate with the outdoors, and shall have a minimum free area of:
- a. 1 in.² per 3,000 BTUH (740 mm² per kW) of the total input rating of all equipment located in the enclosure, and
- b. Not less than the sum of the areas of all vent connectors in the confined space.

WARNING: Do not use the “one permanent opening” method if the equipment room is under negative pressure conditions.

Canadian Installations

CAUTION: All combustion air must be drawn from the air outside of the building; the mechanical equipment room must communicate directly with the outdoors.

1. Ventilation of the space occupied by the heater shall be provided by an opening(s) for ventilation air at the highest practical point communicating with the outdoors. The total cross-sectional area of such an opening(s) shall be at least 10% of the area required in 2. and 3. (below), but in no case shall the cross-sectional area be less than 10 in.² (65 cm²).
2. For heaters using a barometric damper in the vent system, there shall be a permanent air supply opening(s) having a cross section area of not less than 1 in.² per 7,000 BTUH (320 mm² per kW) up to and including 1 million BTUH, plus 1 in.² per 14,000 BTUH (160 mm² per kW) in excess of 1 million BTUH. This opening(s) shall be either located at or ducted to a point not more than 18 in. (450 mm) nor less than 6 in. (152 mm) above the floor level. The duct can also “goose neck” through the roof. The duct is preferred to be straight down

and terminated 18 in. (450 mm) from the floor, but not near piping. This air supply opening requirement shall be in addition to the air opening for ventilation air required in 1. (above).

WARNING: Care must be taken to ensure that the equipment room is not under negative pressure conditions.

3. For heaters when air supply is provided by natural air flow from outdoors for a power burner and there is no draft regulator, drafthood or similar flue gas dilution device installed in the same space, in addition to the opening for ventilation air required in 1., there shall be a permanent air supply opening(s) having a total cross-sectional area of not less than 1 in.² for each 30,000 BTUH (74 mm² per kW) of total rated input of the burner(s), and the location of the opening(s) shall not interfere with the intended purpose of the opening(s) for ventilation air referred to in 1. This opening(s) can be ducted to a point not more than 18 in. (450 mm) nor less than 6 in. (152 mm) above the floor level. The duct can also “goose neck” through the roof. The duct is preferred to be straight down 18 in. (450 mm) from the floor, but not near piping.
4. Refer to the B149 Installation Code for additional information.

Water Piping

General

The heater should be located so that any water leaks will not cause damage to the adjacent area or structures.

CAUTION: This boiler requires forced water circulation when the burner is operating. See Table G and Table H for minimum and maximum flow rates and water pump selection. The pump must be interlocked with the boiler to prevent heater operation without water circulation.

NOTE: Minimum pipe size for in/out connections is 1-1/2” NPT for model 300 and 2” NPT for models 400, 500, 700 and 850. Verify proper flow rates and ΔT as instructed in this manual.

NOTE: The continuous inlet water temperature must be no less than 50°F.

Relief Valve Installation and Piping

WARNING: Pressure relief valve discharge piping must be piped near the floor and close to a drain to eliminate the potential of severe burns. Do not pipe to any area where freezing could occur. Refer to local codes.

The heater is supplied with a Section IV “HV” stamped relief valve sized for the full input of the unit. The relief valve assembly is shipped loose and must be mounted directly to the heater outlet. No valve shall be installed between the heater and the relief valve. The relief valve shall be mounted with its spindle vertical (see Fig. 1, 2 and 3 on page 6). Relief valve discharge piping shall provide no less than the cross sectional area of the relief valve outlet and must be routed to a safe point of discharge. Installation must comply with all national, state and local codes.

WARNING: The pressure relief valve must be installed at the outlet of the boiler. No valve is permitted to be installed between the boiler and the relief valve.

Temperature & Pressure Gauge

The temperature and pressure gauge is shipped loose for field installation and must be installed within 12 inches of the boiler outlet (if possible) in an easily readable location. Installation must comply with ASME Section IV as well as all applicable national, state and local codes.

Hydrostatic Test

Unlike many types of heaters, this heater does not require hydrostatic testing prior to being placed in operation. The heat exchanger has already been factory-tested and is rated for 160 psi operating pressure. However, Raypak does recommend hydrostatic testing of the piping connections to the heater and the rest of the system prior to operation. This is particularly true for hydronic systems using expensive glycol-based anti-freeze. Raypak recommends conducting the hydrostatic test before connecting gas piping or electrical supply.

Leaks must be repaired at once to prevent damage to the heater. NEVER use petroleum-based stop-leak compounds.

To perform hydrostatic test:

1. Connect fill water supply. With bleed valve open, fill heater with water. When water flows from bleed valve, shut off water. Close bleed valve. Carefully fill the rest of the system, making sure to eliminate any entrapped air by using high-point vents. Close feed valve. Test at standard operating pressure for at least 24 hours.
2. Make sure constant gauge pressure has been maintained throughout test.
3. Check for leaks. Repair if found.

Hydronic Heating

Pump Selection

In order to ensure proper performance of your heater system, you must install a correctly-sized pump. Raypak recommends designing for a ΔT within the range of 20°F to 40°F (5°C to 20°C). See Table G for acceptable flow rates for each model (ΔT is the temperature difference between the inlet and outlet water when the heater is firing at full rate).

Feedwater Regulator

Raypak recommends that a feedwater regulator be installed and set at 12 psi minimum pressure at the highest point of the system. Install a check valve or back flow device upstream of the regulator, with a manual shut-off valve as required by local codes.

Piping

All high points should be vented. A heater installed above radiation level must be provided with a low water cut-off device (sales order option F-10). This heater, when used in connection with a refrigeration system, must be installed so that the chilled medium is piped in parallel with the heater with appropriate valves to prevent the chilled medium from entering the heater.

The piping system of a hot water heater connected to heating coils located in air handling units where they may be exposed to circulating refrigerated air, must be equipped with flow control valves or other automatic means to prevent gravity circulation of the heater water during the cooling cycle. It is highly recommended that the piping be insulated.

Air-Separation/Expansion Tank

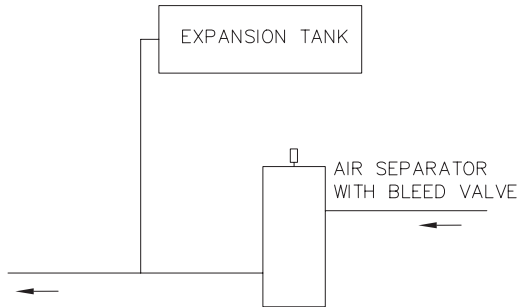
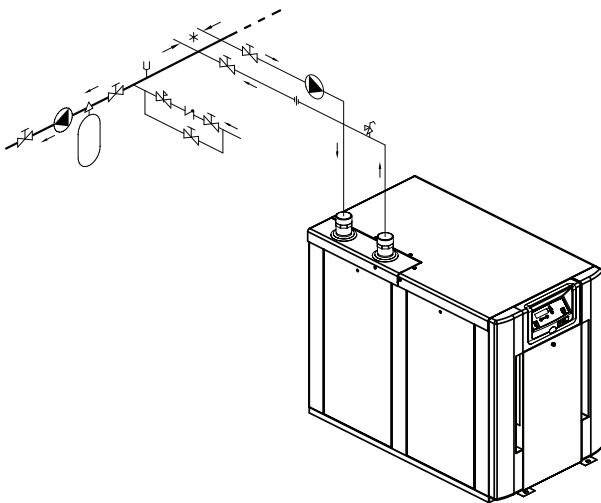

Fig. 6: Air-Separation/Expansion Tank

All heaters should be equipped with a properly sized expansion tank and air separator fitting as shown in Fig. 6 above.

Three-Way Valves

Three-way valves intended to regulate system water temperatures by reducing flow in the boiler should not be used. Raypak heaters are high-recovery, low-mass heaters which are not subject to thermal shock.



*Maximum 4 times the pipe diameter or 12", whichever is less.

Fig. 7: Single Heater — Low-Temperature (Heat Pump) Application with Primary/Secondary Piping

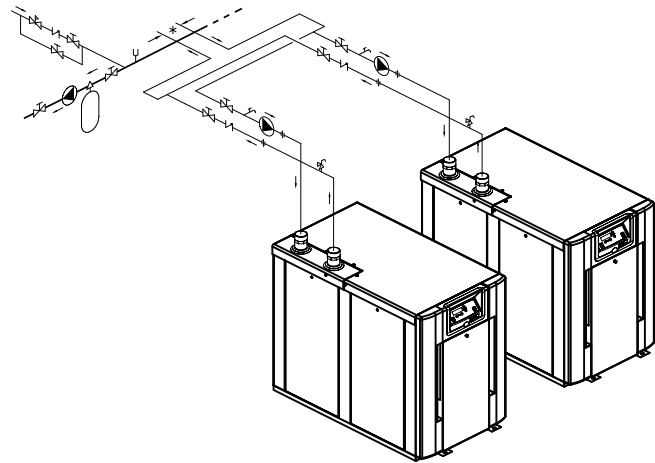

*Maximum 4 times the pipe diameter or 12", whichever is less.

Fig. 8: Dual Heaters (Reverse/Return) with Primary/Secondary Piping

Domestic Hot Water

When designing the water piping system for domestic hot water applications, water hardness should be considered. Table H indicates the suggested flow rates for soft and medium water. Hard water must be softened for direct heating with the XFyre. Water hardness is expressed in grains per gallon.

Model No.	20°F ΔT		30°F ΔT		40°F ΔT		Min. Flow			Max. Flow		
	gpm	ΔP (ft)	gpm	ΔP (ft)	gpm	ΔP (ft)	gpm	ΔP (ft)	ΔT	gpm	ΔP (ft)	ΔT
300	28	17	19	8	14	5	14	5	40	36	28	16
400	38	18	25	7	19	4	19	4	40	47	29	16
500	47	16	31	7	24	4	24	4	40	56	23	17
700	66	30	44	13	33	7	33	7	40	70	34	19
850	80	40	53	17	40	9	40	9	40	80	40	20

Notes: Basis for minimum flow is ΔT. Basis for maximum flow is gpm.

Table G: Heater Rates of Flow and Pressure Drops

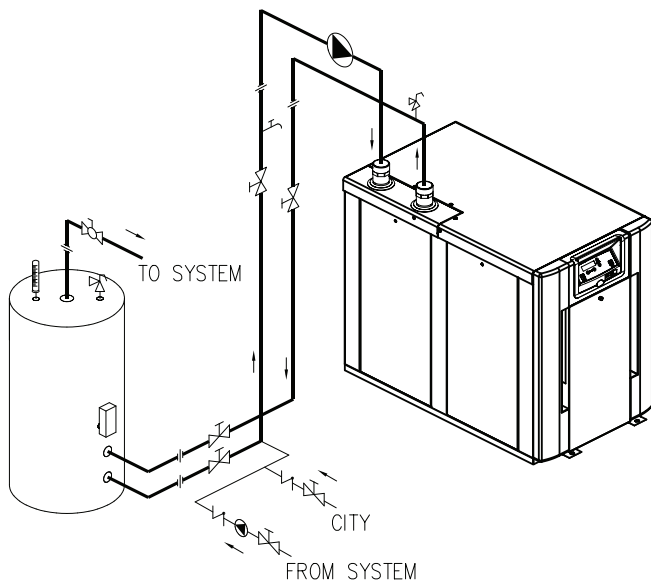

Fig. 9: Single Domestic Hot Water Heater and Storage Tank

NOTE: If local codes require a vacuum relief valve, acquire one locally and install per valve manufacturer's instructions.

Potable Water and Space Heating

CAUTION: When this heater is used for both potable water and space heating, observe the following to ensure proper operation.

1. All piping materials and components connected to the water heater for the space heating application shall be suitable for use with potable water.
2. Toxic chemicals, such as used for boiler treatment, shall not be introduced into the potable water used for space heating.
3. If the heater will be used to supply potable water, it shall not be connected to any heating system or components previously used with a non-potable water heating appliance.
4. When the system requires water for space heating at temperatures higher than 140°F (60°C), a means such as a mixing valve shall be installed to temper the water in order to reduce scald hazard potential.

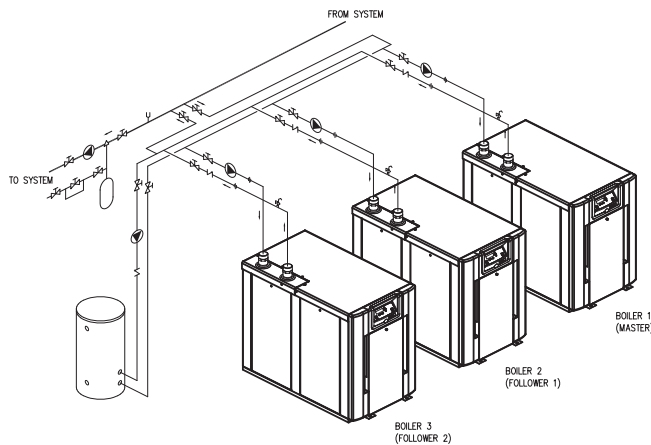

Fig. 10: Multiple Boilers — Reverse Return, Primary/Secondary Piping with Indirect DHW

Model No.	Soft (0–4 grains per gallon)					Medium (5–15 grains per gallon)				
	ΔT	gpm	ΔP	MTS	SHL	ΔT	gpm	ΔP	MTS	SHL
300	30	19	8	1-1/2	10	24	24	17	1-1/2	19
400	30	25	7	2	8	20	38	18	2	21
500	30	31	7	2	8	20	47	16	2	20
700	30	44	13	2	17	20	66	30	2	38
850	32	51	16	2	20	24	67	28	2	36

ΔT = Temperature rise, °F.

ΔP = Pressure drop through heat exchanger, ft.

SHL = System head loss, ft (based on heater and tank placed no more than 5 ft apart and equivalent length of 25 ft of tubing).

gpm = Gallons per minute, flow rate.

MTS = Minimum tubing size.

CAUTION: For scale free operation with Medium water (5–15 grains per gallon of total hardness), the operating control must NOT be set higher than 130°F. For higher than 130°F operation, or Hard water (>16 grains per gallon of total hardness), a water softener/treatment system must be utilized.

Table H: Domestic Water Heater Flow Rate Requirements

Gas Supply

DANGER: Make sure the gas on which the heater will operate is the same type as specified on the rating plate.

Gas piping **must** have a sediment trap ahead of the heater gas controls, **and** a manual shut-off valve located outside the heater jacket. It is recommended that a union be installed in the gas supply piping adjacent to the heater for servicing. The gas supply pressure to the heater must not exceed 10.5 in. WC for natural gas or 13.0 in. WC for propane gas. A pounds-to-inches regulator must be installed to reduce the gas supply pressure if it is higher than noted above. This regulator should be placed a minimum distance of 10 times the pipe diameter upstream of the heater gas controls. Refer to Table J for maximum pipe lengths.

Gas Supply Connection

CAUTION: The heater must be disconnected from the gas supply during any pressure testing of the gas supply system at test pressures in excess of 1/2 psi (3.45 kPa).

The heater must be isolated from the gas supply piping system by closing the upstream manual shut-off valve during any pressure testing of the gas supply piping system at test pressures equal to or less than 1/2 psi (3.45 kPa). Relieve test pressure in the gas supply line prior to re-connecting the heater and its manual shut-off valve to the gas supply line. **FAILURE TO FOLLOW THIS PROCEDURE MAY DAMAGE THE GAS VALVE.** Over-pressurized gas valves are not covered by warranty. The heater and its gas connections shall be leak-tested before placing the appliance in operation. Use soapy water for leak test. DO NOT use an open flame.

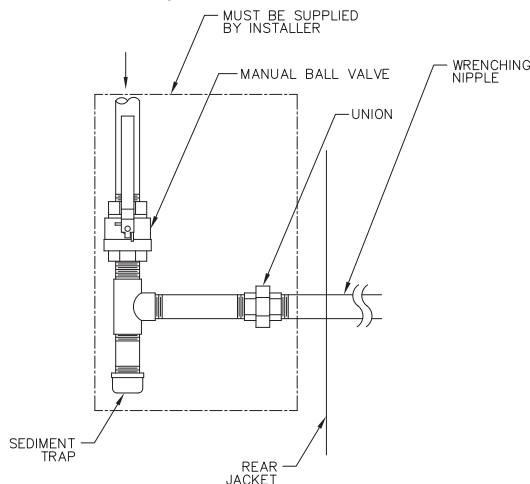

Fig. 10: Gas Supply Connection

CAUTION: Do not use Teflon tape on gas line pipe thread. A pipe compound rated for use with natural and propane gases is recommended. Apply sparingly only on male pipe ends, leaving the two end threads bare.

CAUTION: Support gas supply piping with hangers, not by the heater or its accessories. Make sure the gas piping is protected from physical damage and freezing, where required.

Gas Supply Pressure

A minimum of 4.0 in. WC and a maximum of 10.5 in. WC upstream gas pressure is required under load and no-load conditions for natural gas. A minimum of 4.0 in. WC and a maximum of 13.0 in. WC is required for propane gas. The gas pressure regulator(s) supplied on the heater is for low-pressure service. If upstream pressure exceeds these values, an intermediate gas pressure regulator, of the lockup type, must be installed.

When connecting additional gas utilization equipment to the gas piping system, the existing piping must be checked to determine if it has adequate capacity for the combined load. The gas valve pressure regulator on the heater is nominally preset as noted in Table I.

During normal operation, carbon dioxide should be 8.5 to 9.0% at full fire for natural gas and between 9.0 and 9.5% for propane gas. Carbon monoxide should be <150 ppm.

Model No.	Manifold Pressure (in. WC)			
	Natural Gas		Propane Gas	
	High	Low	High	Low
300	-0.2	-0.1	-0.2	-0.1
400	-0.2	-0.1	-0.2	-0.1
500	-0.4	-0.1	-0.4	-0.1
700	-1.5	-0.2	-2.2	-0.2
850	-2.7	-0.2	-1.6	-0.1

NOTE: Manifold pressures should be ± 0.3 in. WC.

Table I: Manifold Gas Pressure Settings

Model No.	3/4" NPT		1" NPT		1-1/4" NPT		1-1/2" NPT		2" NPT	
	N	P	N	P	N	P	N	P	N	P
300	15	30	45	100	175	400	390			
400			30	70	120	275	270	414		
500			15	40	65	150	150	350		
700					42	96	96	220	310	795
850					25	55	55	125	175	450

Natural Gas – 1,000 BTU/ft³, 0.60 specific gravity at 0.5 in. WC pressure drop
 Propane Gas – 2,500 BTU/ft³, 1.53 specific gravity at 0.6 in. WC pressure drop

Table J: Maximum Equivalent Pipe Length

Electrical Power Connections

Installations must follow these codes:

- National Electrical Code and any other national, state, provincial or local codes or regulations having jurisdiction.
- Safety wiring must be NEC Class 1.
- Heater must be electrically grounded as required by the NEC.
- In Canada, CSA C22. 1 C.E.C. Part 1.

The XFYre 300–850 heaters are wired for 120 V single-phase 60 Hz power. Consult the wiring diagram shipped with the heater. Before starting the heater, check to ensure proper voltage to the heater and pump(s). A larger circuit breaker may be needed for pumps larger than 1/4 hp.

Boiler pumps up to 1 hp and DHW pumps up to 1/4 hp get their power supply directly from the heater power supply (connections in rear wiring box). XFYre heaters

may power up to two pumps directly (1 hp max boiler pump, 3 A max DHW pump) and may control a third system pump, depending on the configuration of the controller and the installation requirements. Install a circuit breaker sized sufficiently for both the heater and the pump(s). DHW pumps larger than 1/4 hp or 3 A must use a separate power supply and run the power through an external field supplied pump contactor. Use appropriately-sized wire as defined by NEC, CSA and/or local codes. All primary wiring should be 125% of minimum rating.

If any of the original wire as supplied with the heater must be replaced, it must be replaced with 105°C wire or its equivalent.

All 120 VAC field wiring connections to the XFYre heater are made inside the rear wiring box as shown in Fig. 11a. Power to the XFYre heater should be connected to terminals 1, 2, and 3 as shown in Fig. 11a. Low voltage wiring is connected to the field wiring board at the front of the unit. Sensors, Thermostat (TT)

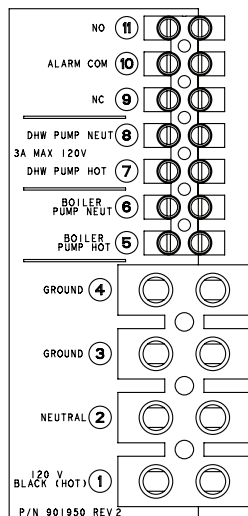

Fig. 11a: Wiring Electrical Connections

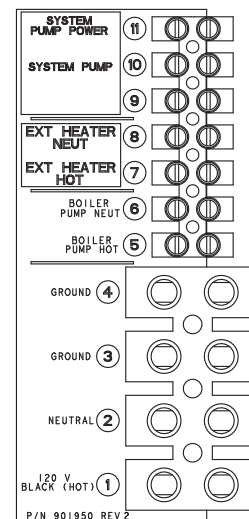

Fig. 11b: Wiring Electrical Connections Cascade Master

contacts, optional 0–10 VDC control wiring and cascade connections are wired into the front mounted field wiring board as shown in Fig. 15–19.

Field-Connected Controllers

It is strongly recommended that all individually-powered control modules and the heater should be supplied from the same power source.

NOTE: Field-supplied isolation relays should be installed when field-connected controllers are mounted more than 50 equivalent feet (18 AWG) from heater.

Check the Power Source

NOTE: Minimum 18 AWG, 105°C, stranded wire must be used for all low voltage (less than 30 volts) external connections to the unit. Solid conductors should not be used because they can cause excessive tension on contact points. Install conduit as appropriate. All high voltage wires must be the same size (105°C, stranded wire) as the ones on the unit or larger.

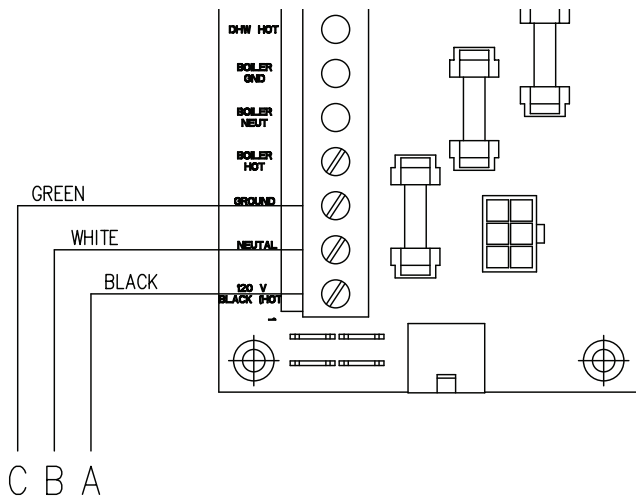

Fig. 12: Wiring Connections

WARNING: Using a multi-meter, check the following voltages at the circuit breaker panel prior to connecting any equipment. Make sure proper polarity is followed and house ground is proven. (See Fig. 13.)

Check the power source:

AC = 108 VAC Minimum, 132 VAC MAX
 AB = 108 VAC Minimum, 132 VAC MAX
 BC = <1 VAC Maximum

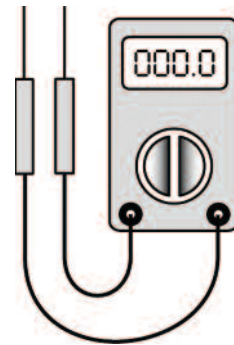

Fig. 13: Multi-meter

Making the Electrical Connections

Refer to Fig. 11a–19.

1. Verify that circuit breaker is properly sized by referring to heater rating plate. A dedicated circuit breaker should be provided and sized for the heater and all pumps powered through the heater.

NOTE: Current draw noted on rating plate does not include pump current.

2. Turn off all power to the heater. Verify that power has been turned off by testing with a multi-meter prior to working with any electrical connections or components.
3. Observe proper wire colors while making electrical connections. Many electronic controls are polarity sensitive. Components damaged by improper electrical installation are not covered by warranty.
4. Provide overload protection and a disconnect means for equipment serviceability as required by local and state code.
5. Install heater controls, thermostats, or building management systems in accordance with the applicable manufacturers' instructions.
6. Conduit should not be used as the earth ground.

NOTE: A grounding electrode conductor shall be used to connect the equipment grounding conductors, the equipment enclosures, and the grounded service conductor to the grounding electrode.

Field Wiring Connections

DANGER: SHOCK HAZARD

CAUTION: Label all wires prior to disconnection when servicing controls. Wiring errors can cause improper and dangerous operation. Verify proper operation after servicing.

Make sure electrical power to the heater is disconnected to avoid potential serious injury or damage to components.

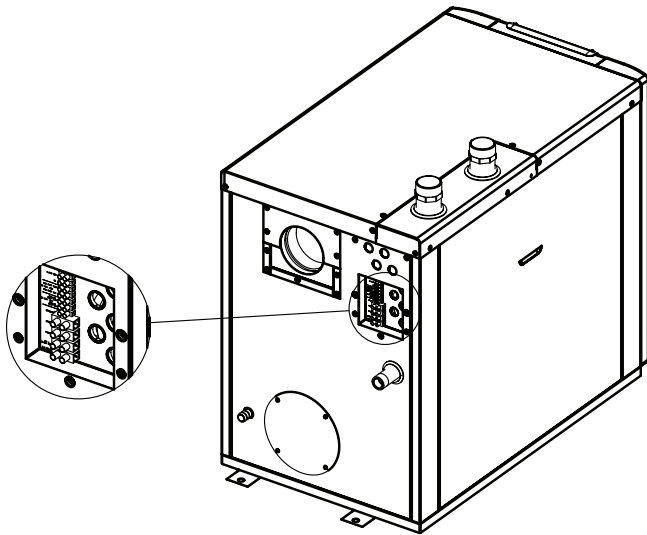

Fig. 14: Rear Wiring Location

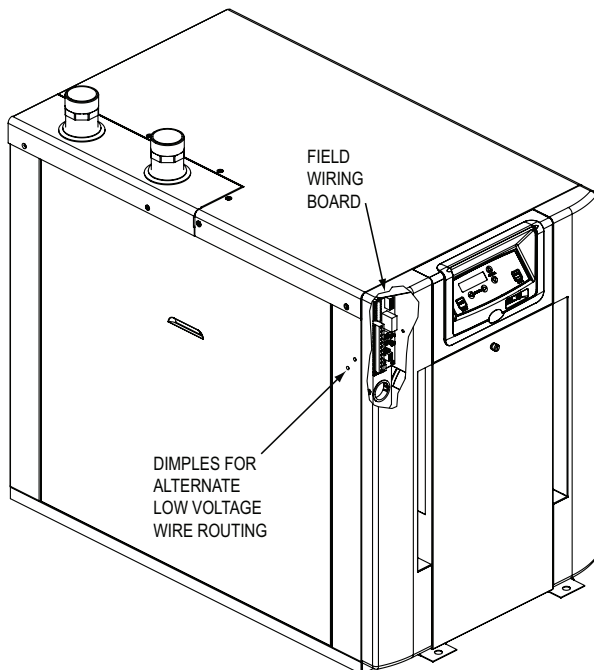

Fig. 15: Front Wiring Location

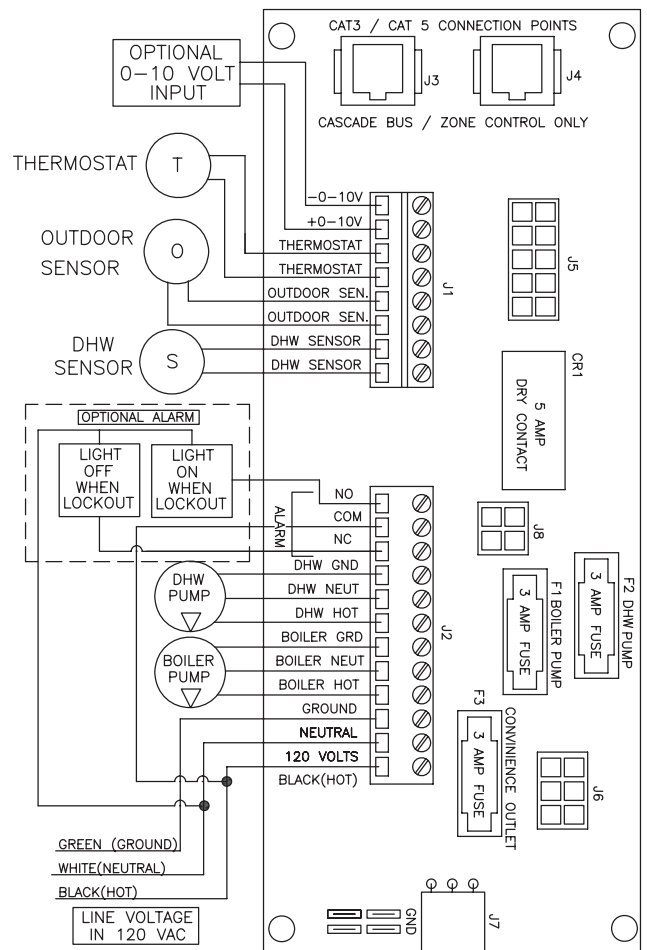

Fig. 16: XFire Single Heater Control

Wiring the Thermostat

1. Connect the room thermostat to the terminals marked THERMOSTAT in the electrical junction box (shown in Fig. 16). Alternately, any dry contact closure across these terminals will enable the XFire unit to run. Caution should be used to ensure neither of the terminals becomes connected to ground.
2. Mount the thermostat on an inside wall as central as possible to the area being heated, but away from drafts or heat producing devices, such as television sets, that could effect the ability of the thermostat to measure the room temperature accurately.
3. If the thermostat is equipped with an anticipator, and it is connected directly to the XFire boiler, the anticipator should be set at .1 amps. If the thermostat is connected to other devices, the anticipator should be set to match the power requirements of the device it is connected to. See the instruction manual for the connected devices for further information.

Wiring the Outdoor Sensor

1. There is no connection required if an outdoor sensor is not used in this installation.
2. If using an Outdoor Sensor, connect the wires for sensor to the terminals marked OUTDOOR SEN (shown in Fig. 16) in the electrical junction box. Caution should be used to ensure neither of these terminals becomes connected to ground.
3. Use a minimum 22 AWG wire for runs of 100 feet or less, and minimum 18 AWG wire for runs of up to 150 feet.
4. Mount the outdoor sensor on an exterior surface of the building, preferably on the north side in an area that will not be affected by direct sunlight and that will be exposed to varying weather conditions.

Wiring the Indirect Sensor

1. There is no indirect sensor connection required if an indirect water heater is not used in the installation.
2. The XFyre boiler will operate an indirect fired water heater with either a thermostat type aquastat installed in the indirect tank or a Raypak tank sensor. When a tank sensor is used, the XFyre control will automatically detect its presence and a demand for heat from the indirect water heater will be generated when the tank temperature falls below the user settable setpoint by more than the user selectable DHW DIFF. The demand will continue until the sensor measures that the indirect water heater temperature is above the setpoint.
3. Connect the indirect tank sensor to the terminals marked DHW SENSOR (shown in Fig. 16) in the electrical junction box. Caution should be used to ensure neither of these terminals becomes connected to ground.

Wiring the Optional 0–10 Volt Building Control Signal

1. A signal from a building management system may be connected to the XFyre boiler to enable remote control. This signal should be a 0–10 volt positive DC signal. When this input is enabled using the installer menu, a building control system can be used to control either the setpoint temperature or the heat output of the XFyre boiler. The control interprets the 0–10 volt signal as follows. When the signal is between 0 and 1 volt, the XFyre boiler will be in stand by mode, not firing. When the signal rises above 1 volt, the XFyre boiler will ignite. As the signal continues to rise towards its maximum of 10 volts, the XFyre boiler will increase either in setpoint temperature or firing rate, depending on the setting of screen 17 in the installer menu. See the Installer Menu section for details on the setting of screens 16 and 17 for this option.
2. Connect a building management system or other auxiliary control signal to the terminals marked +0–10 V and -0–10 V in the electrical junction box (shown in Fig. 16) Caution should be used to ensure that the +0–10 V connection does not become connected to ground.

Wiring the Cascade System Communication Bus

1. Use standard CAT3 or CAT5 computer network patch cables to connect the communication bus between each of the boilers. These cables are readily available at any office supply, computer, electronic, department or discount home supply store in varying lengths.
2. It is recommended that the shortest length cable possible be used to reach between the boilers and create a neat installation. Do not run unprotected cables across the floor or where they will become wet or damaged. Avoid running communication cables parallel with, or close to or against, high voltage (120 volt or greater) wiring. Raypak recommends that the total maximum length of communication bus cables not exceed 200 feet.

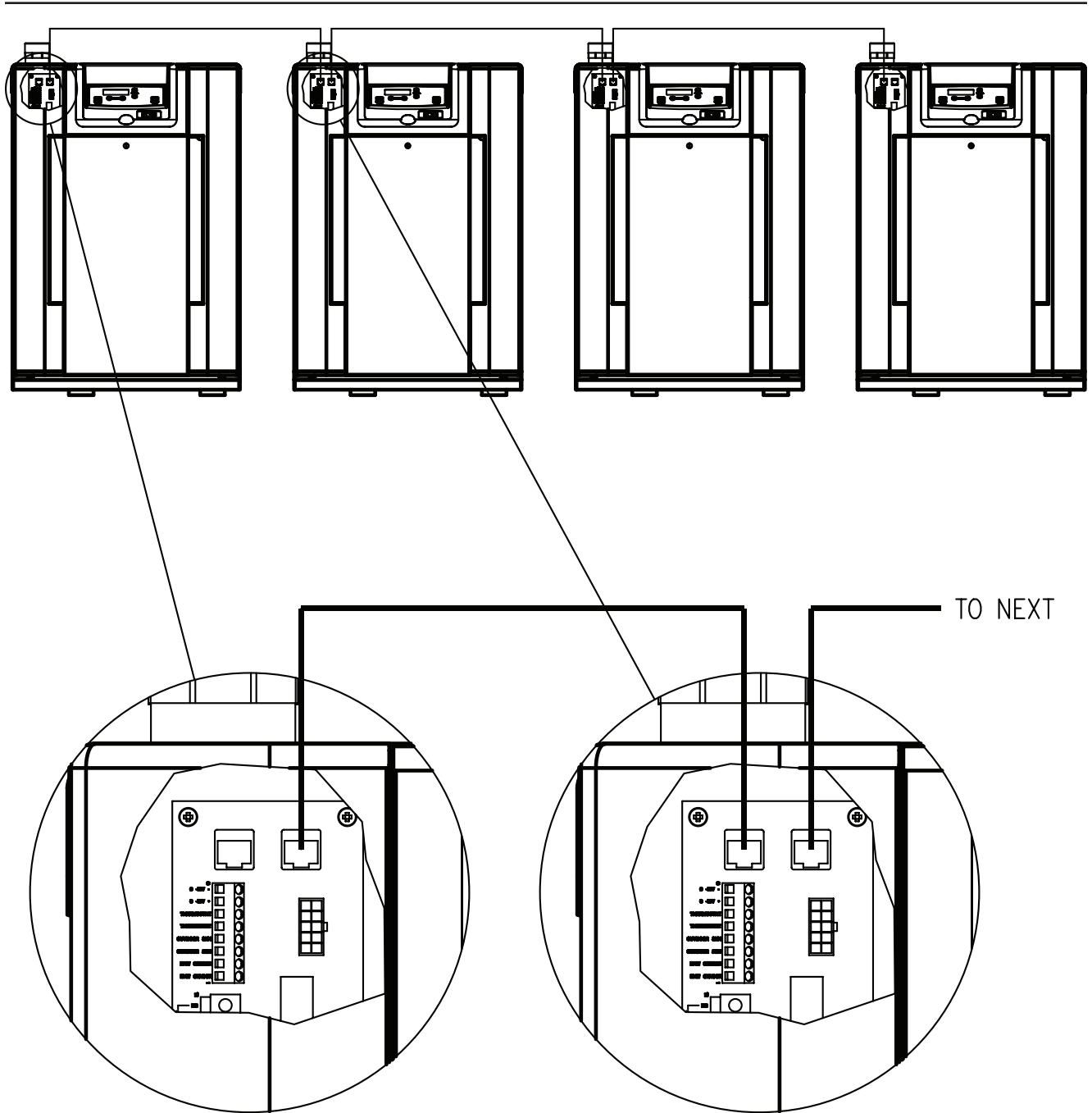
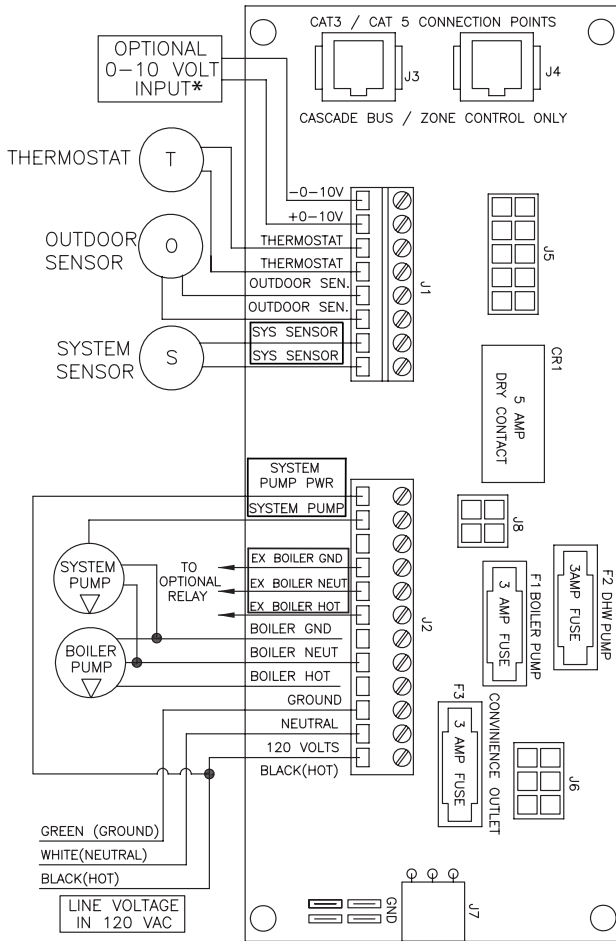

Fig. 17: XFYre Cascade System Wiring

3. Create a hole to route the communication cables through where the dimples are in the side of the cabinet (see Fig. 15), or route the wires to the rear junction box and out of the cabinet.
4. Connect the boilers in a daisy chain configuration as shown in Fig. 17 above. It is best to wire the boilers using the shortest wire runs rather than trying to wire them in the order that they are

addressed. The communication bus jacks on the customer connection panel are interchangeable so you can use either one or both in any order to connect the cable to. If you have connected the boilers to each other properly, two of the boilers will have one open connection port on them.



* - May be configured as DHW SENSOR for single boiler Cascade with Indirect

Fig. 18: XFYre Cascade Master

Cascade Master Pump and Sensor Wiring

1. On the boiler designated as the Cascade Master, apply the System Sensor and DHW Sensor decals (included) to the field wiring board as shown in Fig. 18. Apply the SYSTEM PUMP and EXT HEATER labels to the wiring electrical connections terminal strip as shown in Fig. 11b on page 17.
2. Connect the system pump hot wire to terminal #11, marked SYSTEM PUMP (see Fig 11b).
3. Connect the system pump neutral to terminal #6, marked BOILER PUMP NEUT, and the pump ground wire to terminal #3, marked GROUND, at the rear terminal strip.
4. Connect a jumper wire from terminal #1, marked 120 V BLACK (HOT), terminal #11, marked SYSTEM PUMP POWER, at the rear terminal strip.

5. Connect the boiler pump to the terminals marked BOILER PUMP NEUT (#6), BOILER PUMP HOT (#5), and GROUND (#4).
6. Connect the system pipe sensor to the terminals marked SYS SENSOR, as shown in Fig. 18.
7. Connect the outdoor sensor (if used) to the terminals marked OUTDOOR SEN.
8. Connect the signal to start the system to the terminals marked THERMOSTAT.

NOTE: This signal can come from a room thermostat or a dry contact closure. No power of any voltage should be fed into either of these terminals.

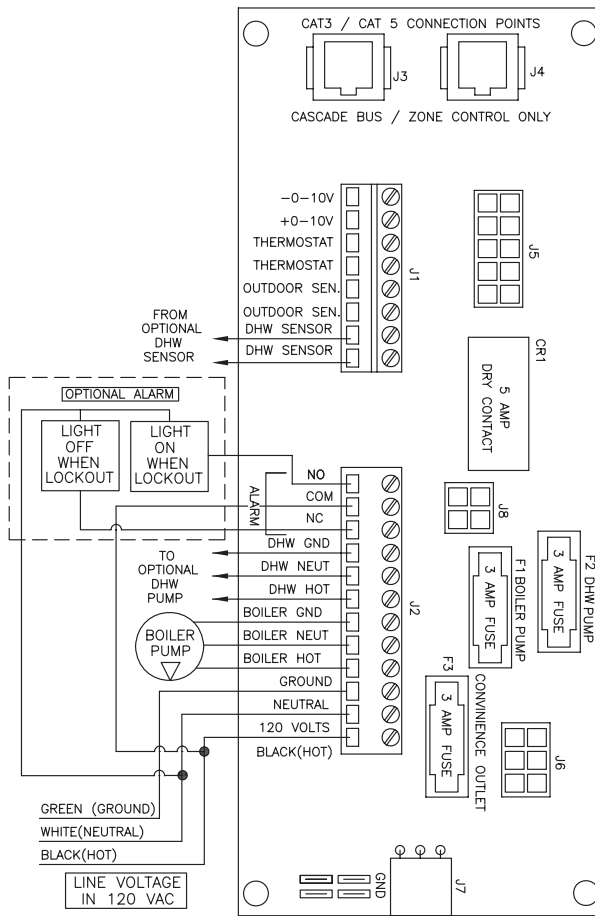

Fig. 19: XFYre Cascade Follower

Cascade Follower Pump and Sensor Wiring

1. Connect the boiler pump to the terminals marked BOILER PUMP NEUT (#6), BOILER PUMP HOT (#5), and GROUND (#4) at the rear terminal strip.
2. If you are using an indirect fired water tank connected directly to the follower boiler, connect the pump for it to the terminals marked DHW PUMP NEUT (#8), DHW PUMP HOT (#7), and GROUND (#3) at the rear terminal strip.

If you desire, an alarm bell or light can be connected to the alarm contacts of the follower boiler. Optionally, the normally-closed alarm contact may be used to turn a device off if the boiler goes into lockout mode. The alarm contacts are rated 5 amps at 120 VAC.

To connect an alarm device, connect the power for the device to the ALARM COM terminal. Connect the alarm device hot wire to the ALARM NO terminal. Connect the neutral or return of the alarm device to the neutral or return of the power for the alarm device.

To connect a device that should be powered off during a boiler lockout condition, follow the same instructions as above except use the ALARM NC terminal rather than the ALARM NO terminal.

Note that in a cascade system the alarm output of the boiler addressed as #1 will also be active if the master boiler has a lockout condition. The alarm output of boilers addressed as 2–7 will only sound if a lockout condition occurs on that specific boiler.

CAUTION: Proper installation of flue venting is critical for the safe and efficient operation of the boiler.

Venting

General

Appliance Categories

Heaters are divided into four categories based on the pressure produced in the exhaust and the likelihood of condensate production in the vent.

Category I – A heater which operates with a non-positive vent static pressure and with a vent gas temperature that avoids excessive condensate production in the vent.

Category II – A heater which operates with a non-positive vent static pressure and with a vent gas temperature that may cause excessive condensate production in the vent.

Category III – A heater which operates with a positive vent pressure and with a vent gas temperature that avoids excessive condensate production in the vent.

Category IV – A heater which operates with a positive vent pressure and with a vent gas temperature that may cause excessive condensate production in the vent.

See Table K for appliance category requirements.

NOTE: For additional information on appliance categorization, see the ANSI Z21.13 Standard and the NFGC (U.S.), or B149 (Canada), or applicable provisions of local building codes.

CAUTION: Condensate drains for the vent piping are required for installations of the XFire. Follow vent manufacturer instructions for installation and location of condensate drains in the vent. Condensate drain traps must be primed with water to prevent gas flue leak and must be routed to an appropriate container for neutralization before disposal, as required by local codes.

WARNING: Contact the manufacturer of the vent material if there is any question about the appliance categorization and suitability of a vent material for application on a Category IV vent system. Using improper venting materials can result in personal injury, death or property damage.

CAUTION: The condensate from the boiler is acidic, with a pH of 3.2 to 4.5. Raypak recommends neutralizing the condensate with a Condensate Neutralizer Kit (Z-12) that can be added to avoid long-term damage to the drainage system and to meet local code requirements. The neutralizer kit is connected to the drain system and contains limestone (Calcium Carbonate) chips that will neutralize the pH level of the condensate. The neutralizer should be checked at least once per year, and the chips should be replenished if necessary. When replacing the chips, they should be no smaller than 3/4" to avoid blockage in condensate piping.

Combustion Air Supply	Exhaust Configuration	Heater Venting Category	Certified Vent Materials	Combustion Air Inlet Material
From Inside Building (Non-Direct Venting)	Vertical Venting	IV	(Canada Only: ULC-S636 PVC and CPVC) Stainless Steel, AL29-4C, ANSI/ASTM D1785 Sch 40 PVC, ANSI/ASTM F441 Sch 40 CPVC	
	Horizontal Through-the-Wall Venting			
From Outside Building (Direct Venting)	Vertical Venting			Galvanized Steel, PVC, ABS, CPVC
	Horizontal Through-the-Wall Venting			

Table K: Venting Category Requirements

Use only approved PVC or CPVC vent materials (in Canada, ULC-S636 approved plastic materials must be used) or special gas vent pipes listed for use with Category IV gas burning heaters, such as the AL29-4C stainless steel vents offered by Heat Fab Inc. (800-772-0739), Protech System, Inc. (800-766-3473), Z-Flex (800-654-5600) or American Metal Products (800-423-4270). Pipe joints must be positively sealed. Follow the vent manufacturer's installation instructions carefully. Vent installations shall be in accordance with Part 7, Venting of Equipment, of the NFGC, ANSI Z223.1/NFPA 54, Section 7, Venting Systems and Air Supply for Appliances, of the B149 Code, or applicable provisions of the local building codes.

WARNING: Do not use foam core or cellular core pipe for venting.

Support of Vent Stack

The weight of the vent stack or chimney must not rest on the heater vent connection. Support must be provided in compliance with applicable codes. The vent should also be installed to maintain proper clearances from combustible materials. Use insulated vent pipe spacers where the vent passes through combustible roofs and walls.

When using PVC or CPVC venting on models 300, 400 and 500, insert the vent pipe 3-5 inches into the unit and provide rigid support to the vent, so that it will not shift laterally.

Vent Terminal Location

1. Condensate can freeze on the vent cap. Frozen condensate on the vent cap can result in a blocked flue condition.

NOTE: During winter months check the vent cap and make sure no blockage occurs from build-up of snow or ice.

WARNING: DO NOT insulate PVC or CPVC vent pipe.

2. Give special attention to the location of the vent termination to avoid possibility of property damage or personal injury.
3. Gases may form a white vapor plume in winter. The plume could obstruct a window view if the termination is installed near windows.
4. Prevailing winds, in combination with below-freezing temperatures, can cause freezing of condensate and water/ice build-up on buildings, plants or roofs.
5. The bottom of the vent terminal and the air intake shall be located at least 12 in. above grade, including normal snow line.
6. Single-wall Category IV metal vent pipe shall not be used outdoors in cold climates for venting gas-fired equipment without insulation.
7. Through-the-wall vents for Category IV appliances shall not terminate over public walkways or over an area where condensate or vapor could create a nuisance or hazard or could be detrimental to the operation of regulators, relief valves, or other equipment.
8. Locate and guard vent termination to prevent accidental contact by people or pets.
9. DO NOT terminate vent in window well, stairwell, alcove, courtyard or other recessed area.
10. DO NOT terminate above any door, window, or gravity air intake. Condensate can freeze, causing ice formations.

11. Locate or guard vent to prevent condensate from damaging exterior finishes. Use a rust-resistant sheet metal backing plate against brick or masonry surfaces.
12. DO NOT extend exposed vent pipe outside of building beyond the minimum distance required for the vent termination. Condensate could freeze and block vent pipe.

NOTE: When using PVC vent termination, insert the two round stainless mesh screens provided with the unit into the tee.

U.S. Installations

Refer to the latest edition of the National Fuel Gas Code.

Vent termination requirements are as follows:

1. Vent must terminate at least 4 ft below, 4 ft horizontally from or 1 ft above any door, window or gravity air inlet to the building.
2. The vent must not be less than 7 ft above grade when located adjacent to public walkways.
3. Terminate vent at least 3 ft above any forced air inlet located within 10 ft.
4. Vent must terminate at least 4 ft horizontally, and in no case above or below unless 4 ft horizontal distance is maintained, from electric meters, gas meters, regulators, and relief equipment.
5. Terminate vent at least 6 ft away from adjacent walls.
6. DO NOT terminate vent closer than 5 ft below roof overhang.
7. The vent terminal requires a 12 in. vent terminal clearance from the wall.
8. Terminate vent at least 1 ft above grade, including normal snow line.
9. Multiple direct vent installations require a 4 ft clearance between the ends of vent caps located on the same horizontal plane.

WARNING: The Commonwealth of Massachusetts requires that sidewall vented heaters, installed in every dwelling, building or structure used in whole or in part for residential purposes, be installed using special provisions as outlined on page 53 of this manual.

Installations in Canada

Refer to latest edition of the B149 Installation Code.

A vent shall not terminate:

1. Directly above a paved sidewalk or driveway which is located between two single-family dwellings and serves both dwellings.
2. Less than 7 ft (2.13 m) above a paved sidewalk or paved driveway located on public property.
3. Within 6 ft (1.8 m) of a mechanical air supply inlet to any building.
4. Above a meter/regulator assembly within 3 ft (915 mm) horizontally of the vertical centerline of the regulator.
5. Within 6 ft (1.8 m) of any gas service regulator vent outlet.
6. Less than 1 ft (305 mm) above grade level.
7. Within 3 ft (915 mm) of a window or door which can be opened in any building, any non-mechanical air supply inlet to any building or the combustion air inlet of any other appliance.
8. Underneath a verandah, porch or deck, unless the verandah, porch or deck is fully open on a minimum of two sides beneath the floor, and the distance between the top of the vent termination and the underside of the verandah, porch or deck is greater than 1 ft (305 mm).

Venting Installation Tips

Support piping:

- horizontal runs—at least every 5 ft (1.5m)
- vertical runs—use braces
- under or near elbows

WARNING: Examine the venting system at least once a year. Check all joints and vent pipe connections for tightness, corrosion or deterioration.

Model No.	Certified Vent Material	Vent and Intake Air Vent Size (in.)	Vertical Vent Height ¹ (ft)		Combustion Air Intake Pipe Material	Vertical Air Inlet Max. Length* (ft)
			Min.	Max.		
300	(Canada Only: ULC-S636 PVC and CPVC) Stainless Steel, AL29-4C, ANSI/ASTM D1785 Sch 40 PVC, ANSI/ASTM F441 Sch 40 CPVC	4	0	100	Galvanized Steel, PVC, ABS, CPVC	100
400						
500						
700		6				
850						

¹ Vent lengths are based on a lateral length of 2 ft. Refer to the latest edition of the NFGC for further details.

* Subtract 10 ft per elbow. Max. 4 elbows.

Table L: Category IV Vertical Vent & Vertical Direct Vent

Venting Configurations

For heaters connected to gas vents or chimneys, vent installations shall be in accordance with the NFGC (U.S.), or B149 (Canada), or applicable provisions of local building codes.

Vertical Venting (Category IV)

CAUTION: This venting system requires the installation of a condensate drain in the vent piping per the vent manufacturer's instructions. Failure to install a condensate drain in the venting system will void all warranties on this boiler.

Installation

The maximum and minimum venting length for this Category IV appliance shall be determined per the NFGC (U.S.) or B149 (Canada).

The diameter of vent flue pipe should be sized according to the NFGC (U.S.) and Appendix B of B149 (Canada). The minimum flue pipe diameter for conventional venting is: 4 in. (102mm) for Models 300, 400 and 500, and 6 in. (152mm) for Models 700 and 850.

The connection from the appliance vent to the stack must be as direct as possible and shall be the same diameter as the vent outlet. The horizontal breaching of a vent must have an upward slope of not less than 1/4 inch per linear foot from the heater to the vent terminal. The horizontal portions of the vent shall also be supported for the design and weight of the material employed to maintain clearances and to prevent physical damage or separation of joints.

NOTE: A vent adapter (field-supplied) may be required to connect the Category IV vent to the boiler.

Termination

The vent terminal should be vertical and should terminate outside the building at least 2 ft above the highest point of the roof that is within 10 ft. The vent cap

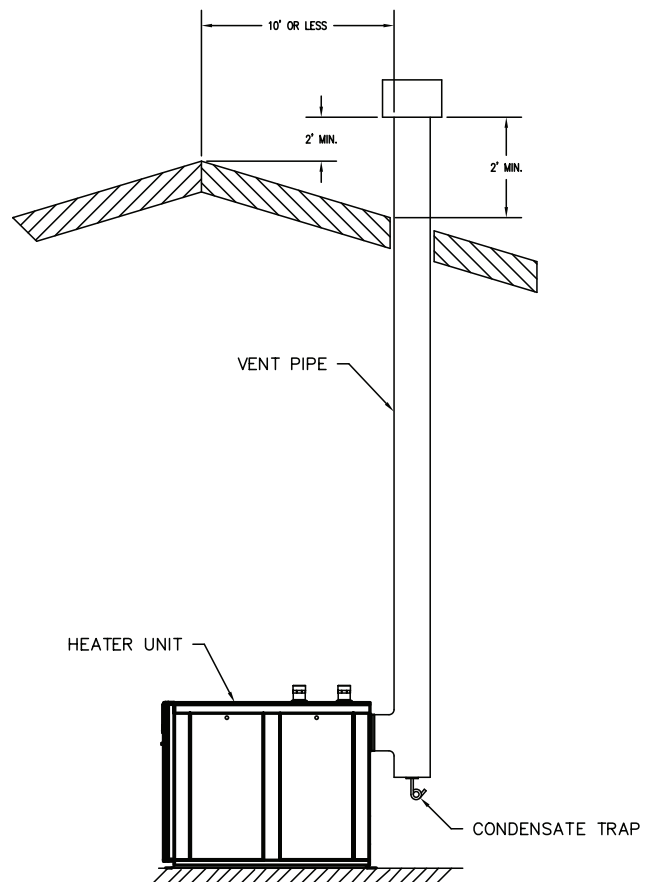

Fig. 20: Vertical Venting

should have a minimum clearance of 4 ft horizontally from and in no case above or below (unless a 4 ft horizontal distance is maintained) electric meters, gas meters, regulators and relief equipment.

The distance of the vent terminal from adjacent public walkways, adjacent buildings, open windows and building openings must be consistent with the NFGC (U.S.) or B149 (Canada). Vents supported only by flashing and extending above the roof more than 5 ft should be securely guyed or braced to withstand snow and wind loads.

NOTE: When using PVC vent termination, insert the round stainless mesh screens provided with the unit into the tee and terminals.

CAUTION: A listed vent cap terminal suitable for connection to the Cat IV vent materials, adequately sized, must be used to evacuate the flue products from the boilers.

Common Venting

The NFGC does not address sizing guidelines for the common venting of multiple Category IV heaters. This is covered in the NFGC under “Engineered Vent Systems”. Table M provides volumes of flue products at full fire for the calculation of appropriate vent and extractor sizing for common venting.

WARNING: Vent connectors serving any other appliances shall not be connected into any portion of mechanical draft systems operating under a positive pressure. If an XFire boiler is installed to replace an existing boiler, the vent system MUST be verified to be of the correct size and of Category IV AL29-4C vent material or approved PVC/CPVC construction (in Canada, ULC-S636 approved plastic materials must be used). If it is NOT, it MUST be replaced.

NOTE: For extractor sizing, typical CO₂ levels are 8.5% for natural gas and 9.5% for propane gas and flue temperatures of approximately 150°F.

At the time of removal of an existing boiler, the following steps shall be followed with each appliance remaining connected to the common venting system placed in operation, while the other appliances remaining connected to the common venting system are not in operation:

- (a) Seal any unused openings in the common venting system.

- (b) Visually inspect the venting system for proper size and horizontal pitch and make sure there is no blockage or restriction, leakage, corrosion and other deficiencies which could cause an unsafe condition.
- (c) As much as possible, close all building doors and windows and all doors between the space in which the appliances remaining connected to the common venting system are located and other spaces of the building. Turn on clothes dryers and any appliance not connected to the common venting system. Turn on any exhaust fans, such as range hoods and bathroom exhausts, so they will operate at maximum speed. Do not operate a summer exhaust fan. Close fireplace dampers.
- (d) Place in operation the appliance being inspected. Follow the lighting instructions. Adjust thermostat so appliance will operate continuously.
- (e) After it has been determined that each appliance remaining connected to the common venting system properly vents when tested as outlined above, return doors, windows, exhaust fans, fireplace dampers and any other gas burning appliance to their previous conditions of use.
- (f) Any improper operation of the common venting system should be corrected so that the installation conforms with the latest edition of the National Fuel Gas Code, ANSI Z223.1 and/or CAN/CSA B149. When re-sizing any portion of the common venting system, the common venting system should be re-sized to approach the minimum size as determined using the appropriate tables in Part 11 of the National Fuel Gas Code, ANSI Z223.1 and/or CAN/CSA B149.

Model No.	Vent Size (inches)	Volume of Flue Products (CFM)
300	4	80
400		105
500		130
700	6	180
850		220

NOTE: Data for 100% firing rate.

Table M: Volume of Flue Products Data

NOTE: Vent and intake piping must be supported so that the weight of the venting is not transferred to the unit. Horizontal runs of vent and intake piping must be supported to prevent sagging.

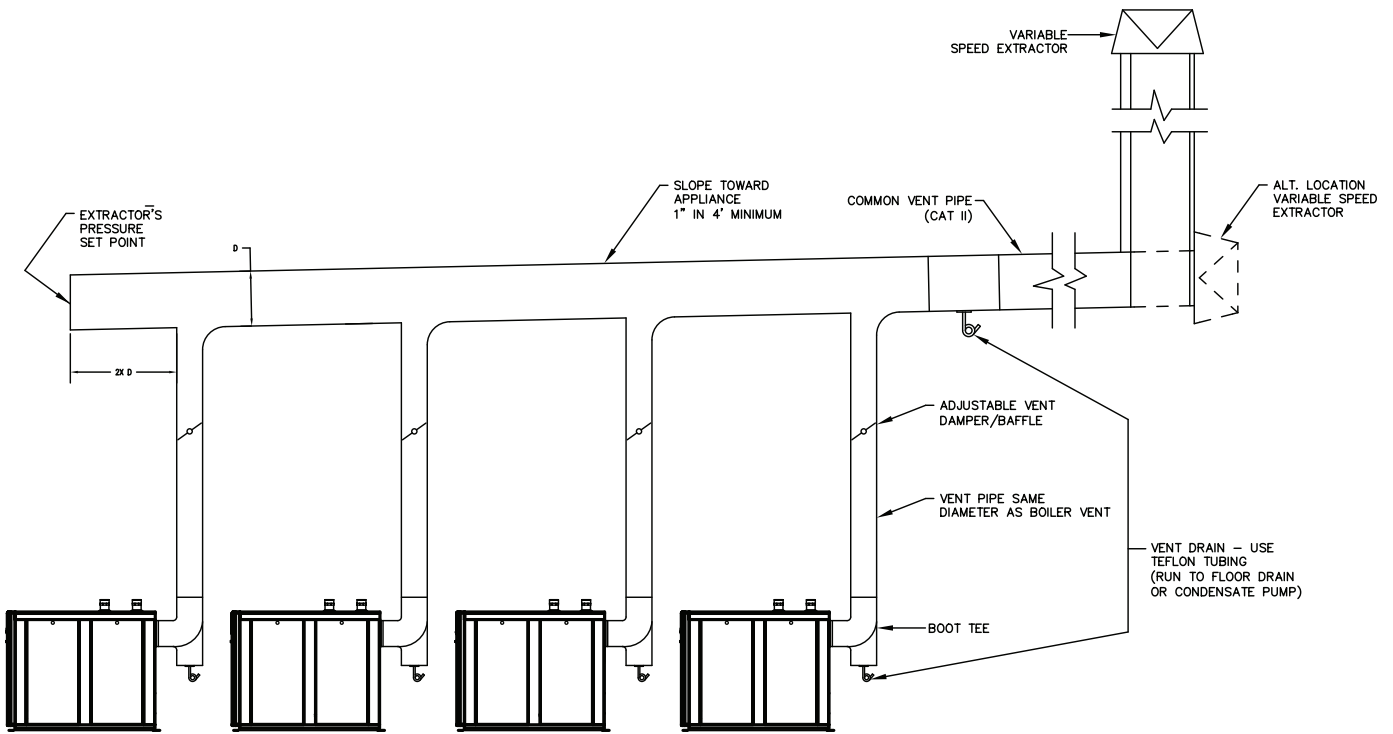

Note: Heaters rotated to show venting connections.

Fig. 21: Typical Common Venting

Horizontal Through-the-Wall Direct Venting (Category IV)

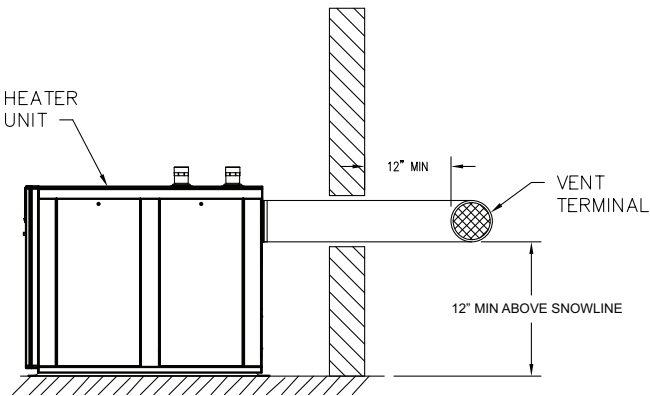

Refer to Table F and local codes.

Fig. 22: Horizontal Through-the-Wall Venting

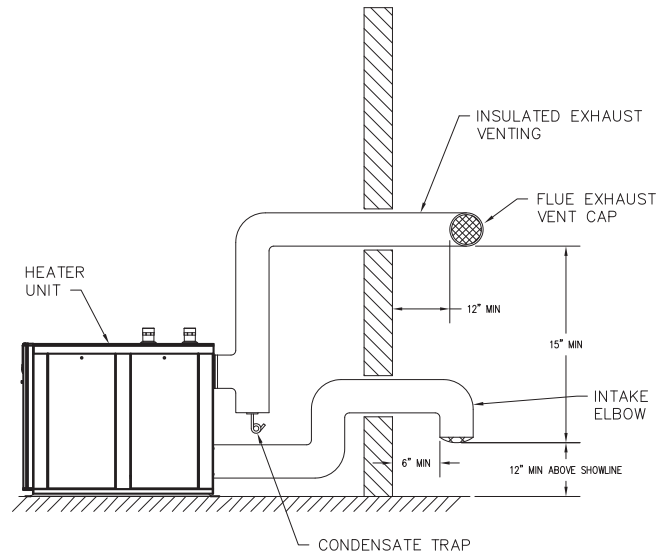

Refer to Table F and local codes.

Fig. 23: Horizontal Through-the-Wall Direct Venting

NOTE: While a drain connection is required in the vent of all XFire installations, the drain can be accomplished in several different ways. The figures in this manual show the drain in a vent tee, however, this can also be accomplished using an inline collector for condensing stacks or an inline vertical or horizontal collector available from several of the listed vent manufacturers.

CAUTION: This venting system requires the installation of a condensate drain in the vent piping per the vent manufacturer's instructions. Failure to install a condensate drain in the venting system will void all warranties on this boiler.

Installation

These installations utilize the heater-mounted blower to draw combustion air and to vent the combustion products to the outdoors. The combustion air intake and the vent are installed horizontally through the wall to the outdoors. Adequate ventilation air must be supplied to the equipment room in accordance with the NFGC (U.S.) or B149 (Canada).

The total length of the horizontal through-the-wall direct vent system should not exceed 200 equivalent ft in length. If combined vent/intake run exceeds 200

equivalent ft, an appropriately sized variable-speed extractor must be used. Each elbow used is equal to 10 ft of straight pipe with a maximum of 4 elbows each on the air intake and vent.

The vent and air intake runs should be balanced to provide approximately the same equivalent length.

The vent cap and air intake elbow are not considered in the overall length of the venting system.

The vent must be installed to prevent flue gas leakage. Care must be taken during assembly to ensure that all joints are sealed properly and are airtight. The vent must be installed to prevent the potential accumulation of condensate in the vent pipes. It is required that:

1. The vent must be installed with condensate drains as directed by the vent manufacturer.
2. The vent must be installed with a slight upward slope of not less than 1/4 inch per foot of horizontal run to the vent terminal.

Termination

The vent cap **MUST** be mounted on the exterior of the building. The vent cap cannot be installed in a well or below grade. The vent cap must be installed at least 1 ft above ground level and above normal snow levels. Only Raypak-approved vent caps may be used. The vent terminal must be located **NO CLOSER** than 12" off the wall.

WARNING: No substitutions of flue pipe or vent cap material are allowed. Such substitutions would jeopardize the safety and health of inhabitants.

Model No.	Size (in.)	Approved Intakes	Approved Plastic Terminals	Approved SS Terminals
300	4	PVC 90° Elbow, Sch 40 Galvanized 90° Elbow, SS 90° Elbow	4" PVC Tee, Sch 40*	FasNSeal FSTT4, Z-Vent 2SVSTTF04
400				
500				
700	6" PVC Tee, Sch 40*		FasNSeal FSTT6, Heat Fab 9690TEE	
850				6

*Must be ULC-S636 materials in Canada.

Table N: Horizontal Vent and Air Intake Terminals

Model No.	Certified Vent Material	Vent and Intake Air Vent Size (in.)	Horizontal Vent Height (ft)		Combustion Air Intake Pipe Material	Air Inlet Max. Length (ft)*
			Min.	Max.		
300	(Canada Only: ULC-S636 PVC and CPVC) Stainless Steel, AL29-4C, ANSI/ASTM D1785 Sch 40 PVC, ANSI/ASTM F441 Sch 40 CPVC	4	0	100	Galvanized Steel, PVC, ABS, CPVC	100
400						
500						
700		6				
850						

* Subtract 10 ft per elbow. Max. 4 elbows.

Table O: Category IV Horizontal Vent & Horizontal Direct Vent

Direct Vent—Vertical

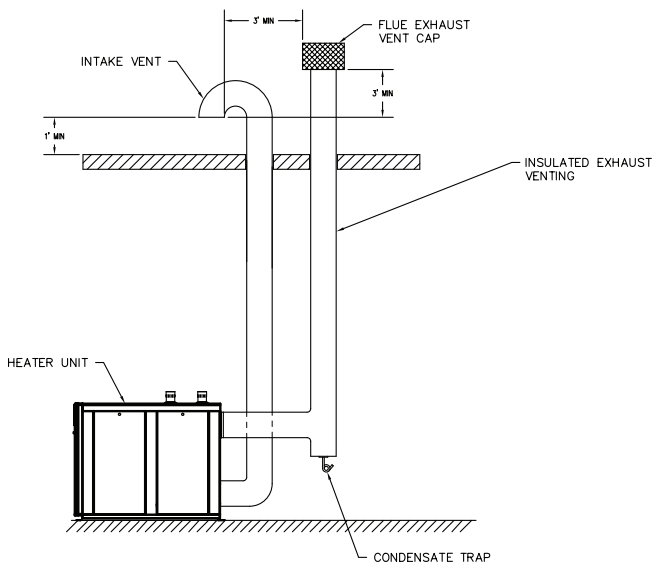

Fig. 24: Direct Vent - Vertical

CAUTION: This venting system requires the installation of a condensate drain in the vent piping per the vent manufacturer's instructions. Failure to install a condensate drain in the venting system will void all warranties on this boiler.

Installation

These installations utilize the heater-mounted blower to draw combustion air from outdoors and vent combustion products to the outdoors.

The total length of air supply pipe cannot exceed the distances listed in Table L. Each elbow used is equal to 10 ft of straight pipe. This will allow installation in any arrangement that does not exceed the lengths shown in Table L.

The vent cap is not considered in the overall length of the venting system.

Care must be taken during assembly that all joints are sealed properly and are airtight.

The vent must be installed to prevent the potential accumulation of condensate in the vent pipes. It is required that:

1. The vent must be installed with a condensate drain as directed by the vent manufacturer.
2. The vent must be installed with a slight upward slope of not more than 1/4 inch per foot of horizontal run to the vent terminal.

Termination

The vent cap **MUST** be mounted on the exterior of the building. The vent cap cannot be installed in a well or below grade. The vent cap must be installed at least 1 ft above ground level and above normal snow levels.

The vent cap **MUST NOT** be installed with any combustion air inlet directly above a vent cap. This vertical spacing would allow the flue products from the vent cap to be pulled into the combustion air intake installed above.

This type of installation can cause non-warrantable problems with components and poor operation of the boiler due to the recirculation of flue products. Multiple vent caps installed in the same horizontal plane must have a 4 ft clearance from the side of one vent cap to the side of the adjacent vent cap(s).

Combustion air supplied from outdoors must be free of particulate and chemical contaminants. To avoid a blocked flue condition, keep the vent cap clear of snow, ice, leaves, debris, etc.

WARNING: No substitutions of flue pipe or vent cap material are allowed. Such substitutions would jeopardize the safety and health of inhabitants.

The stainless steel flue direct vent cap must be furnished by the boiler manufacturer in accordance with its listing (sales order option D-15).

Outdoor Installation

Outdoor models must be vented with listed vent material per the following instructions and installed with the optional factory-supplied outdoor vent kit. A special vent terminal is provided in accordance with CSA requirements. These must be installed as illustrated in Fig. 25.

Care must be taken when locating the unit outdoors, because the flue gases discharged from the vent cap can condense as they leave the cap. Improper location can result in damage to adjacent structures or building finish. For maximum efficiency and safety, the following precautions must be observed:

1. Outdoor models must be installed outdoors and must use the outdoor vent cap available from the manufacturer (sales order option D-11).
2. Periodically check venting system. The unit's venting areas must never be obstructed in any way and minimum clearances must be observed to prevent restriction of combustion and ventilation air. Keep area clear and free of combustible and flammable materials.
3. Do not locate adjacent to any window, door, walkway, or gravity air intake. The vent must be located a minimum of 4 ft horizontally from such areas.
4. Install above grade level and above normal snow levels.

5. Vent terminal must be at least 3 ft above any forced air inlet located within 10 ft.
6. Adjacent brick or masonry surfaces must be protected with a rust-resistant sheet metal plate.

Freeze Protection

NOTE: The vent cap must be furnished by the boiler manufacturer in accordance with its listing (sales order option D-11).

NOTE: Condensate can freeze on the vent terminal. Frozen condensate on the vent terminal can result in a blocked flue condition.

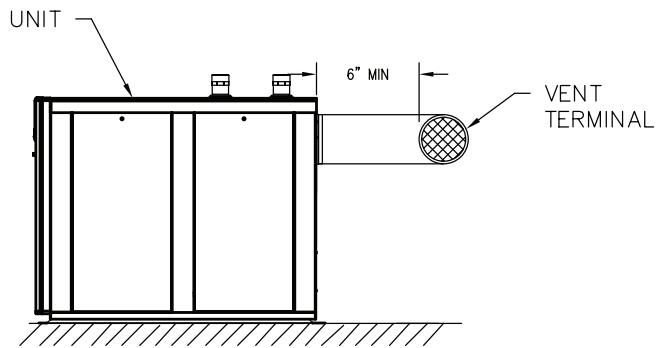

Fig. 25: Outdoor Venting

Model No.	Size (in.)	Approved Plastic Terminals	Approved SS Terminals
300	4	PVC Tee, Sch 40*	FasNSeal FSTT4, Z-Vent 2SVSTTF04
400			
500			
700	6	PVC Tee, Sch 40*	FasNSeal FSTT6, Heat Fab 9690TEE
850			

*Must be ULC-S636 materials in Canada.

Table P: Outdoor Vent Terminals

The Raypak electronic temperature control includes a freeze protection feature. In the event the temperature drops below 40°F at any of the temperature sensors, the pump is turned on and will remain on until the temperatures at all sensors rise to 45°F.

Controls

WARNING: Installation, adjustment and service of controls, including timing of various operating functions, must be performed by a qualified installer, service agency or the gas supplier. Failure to do so may result in control damage, malfunction, property damage, personal injury, or death.

WARNING: Turn off the power to the boiler before installation, adjustment or service of any controls. Failure to do so may result in board damage, malfunction, property damage, personal injury, or death.

CAUTION: This appliance has provisions to be connected to more than one supply source. To reduce the risk of electric shock, disconnect all such connections before servicing.

CAUTION: Risk of electric shock: More than one disconnect switch may be required to de-energize the equipment before servicing.

Ignition Control Functions

When there is a call for heat, the combustion air blower starts to purge air from the combustion chamber. After the pre-purge, the igniter is energized. The standard ignition module will lock out after failing to light four times or after losing flame three times during a single heat demand. To reset it, press and release the **ESC/RESET** button located on the user interface. The control will automatically reset after 1 hour. When in lock out, the control will run the blower for a 1 minute purge cycle. **Turning off the power to the heater WILL NOT reset the ignition module.**

The single-try ignition module (part of the CSD-1 option) will attempt to light only one time before locking out. To reset it, press the **ESC/RESET** button on the user interface.

NOTE: Each ignition module is specific to a single model size. Care should be taken not to use a module intended for a different model size.

High Limit — Manual Reset

This boiler is equipped with a fixed-setting manual reset high limit temperature device as standard or it may have an optional adjustable setting manual reset high limit temperature device.

The fixed-setting manual-reset high limit is located on the outlet pipe of the heat exchanger on the left side of the boiler (accessible through the front door for reset as necessary).

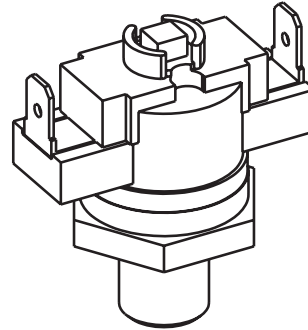

Fig. 26: High Limit (Manual Reset)

High Limit — Auto Reset (Optional)

This heater is equipped with a fixed auto-reset high limit temperature device.

The optional auto reset high limit is located on the heat exchanger header, near the outlet.

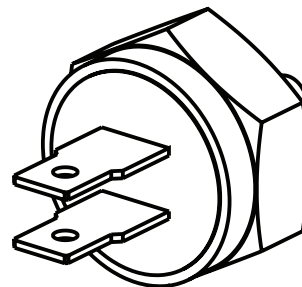

Fig. 27: High Limit (Auto Reset)

Flow Switch

This standard, dual-purpose control, mounted and wired in series with the main gas valve, shuts off the boiler in case of pump failure or low water flow.

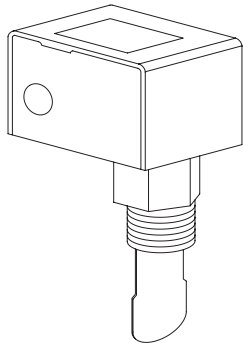

Fig. 27: Flow Switch

Low Water Cut-Off (Optional)

The optional low water cut-off automatically shuts down the burner whenever water level drops below the level of the sensing probe. A 5-second time delay prevents premature lockout due to temporary conditions such as power fluctuations or air pockets.

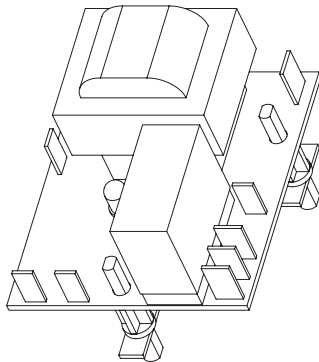

Fig. 28: Low Water Cut-Off

High & Low Gas Pressure Switches (Optional)

The optional low gas pressure switch connection mounts upstream of the gas valve (on the inlet flange to the gas valve) and is accessible through the removable access panels on the rear of the boiler to reset the gas pressure switch, as necessary. It is used to ensure that sufficient gas pressure is present for proper valve/regulator performance. The low gas pressure switch automatically shuts down the boiler if the gas supply drops below the factory setting of 3.0 in. WC for natural gas or propane gas.

The optional high gas pressure switch connection mounts down-stream of the gas valve. Special ports are located on the backside of the gas valve and accessible from the front of the boiler (to reset the gas pressure switch), as necessary. If the gas pressure regulator in the valve fails, the high gas pressure switch automatically shuts down the burner.

Operation of either the High or Low Gas Pressure Switch will turn on an LED inside the switch housing. Push the top of the plastic switch housing as shown in Fig. 29 to reset a tripped pressure switch. The LED will go out when the switch is reset.

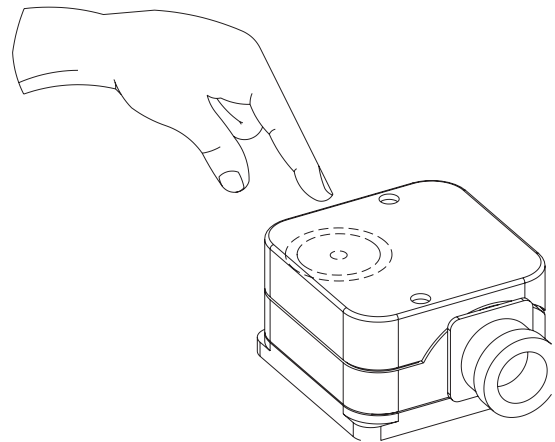

Fig. 29: High/Low Gas Pressure Switch

Blocked Vent Switch

This heater is equipped with a blocked vent pressure switch to prevent the operation of the boiler when too much of the vent is blocked. This switch is located on the left side of the heater near the left rear corner.

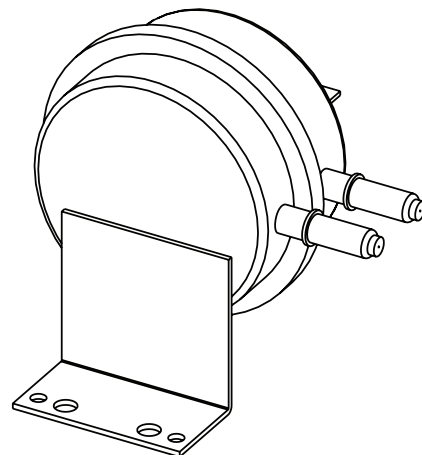

Fig. 30: Blocked Vent Switch

Blocked Condensate Drain Sensor

This boiler is equipped with a condensate sensor to prevent operation when the condensate water level is too high. The boiler shutting down from the condensate sensor is indicative of a blocked drain or problem with the condensate management system. The condensate sensor is located inside the condensate reservoir at the rear of the boiler.

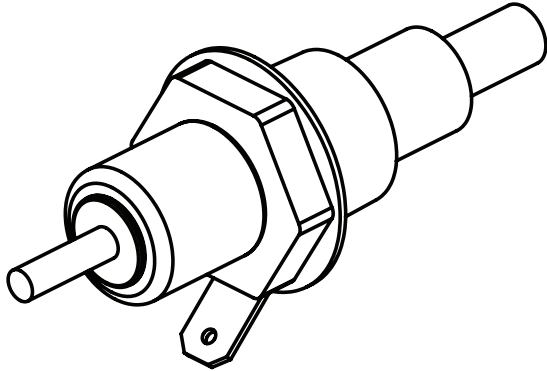

Fig. 31: Condensate Drain Sensor

Operating Instructions

Remove the front door. If you smell gas, **STOP**. Follow listed safety instructions. If you do not smell gas, follow the next steps.

1. Turn on all electric power to appliance.
2. Adjust the temperature setpoint of the XFyre as desired. The factory default setting is 160°. If changes are necessary follow "Adjusting The XFyre Setpoint" in this section.
3. On the initial start-up of units with gas pressure switches, the control user interface will display **flue/gas press**. This is a low gas pressure switch lock-out from the factory-installed low gas pressure switch. You will also see a yellow LED illuminated under the cover of the low gas pressure switch. Once the gas is turned on, reset the gas pressure switch by **FIRMLY** pressing on top of the plastic cover over the red reset button. The yellow LED will go out after the switch has been reset. Press and hold the **ESC/RESET** key on the control panel for about 4 seconds to begin normal operation.
4. Set the thermostat to the desired setting.

5. If the appliance fails to start, refer to the Troubleshooting section in the back of this manual.

NOTE: Before you can change the temperature from the factory setting of 160 degrees, you must make sure none of the thermostats are calling for heat. The controller will not memorize a program setting while in a heating cycle.

User Menu

The user menu consists of several items that can be adjusted. To access the user menu, press and hold the **ENTER/MENU** key for 5 seconds. Using the **UP** and **DOWN**, and **LEFT** and **RIGHT** arrow keys, enter **600**, then press **ENTER/MENU**. Scroll through the list of adjustable items by pressing the **LEFT** or **RIGHT** arrow keys. Once the desired item is displayed, press the **ENTER/MENU** key to select it. The screen will begin to flash. Press the **DOWN** arrow key to decrease the values, and the **UP** arrow key to increase them. To store the changes, press the **ENTER/MENU** key. The display returns to normal mode after one minute. Pressing the **ESC/RESET** key before storing changes will restore the original value. Refer to Fig. 32 for display and key locations.

Adjusting the XFyre Setpoint

To adjust the temperature on the XFyre:

- Press the **ENTER/MENU** key for 5 seconds to bring up the code menu. Enter **600** to access the user menu.
- Press the **DOWN** arrow key to decrease the temperature (minimum setpoint is 50°F).

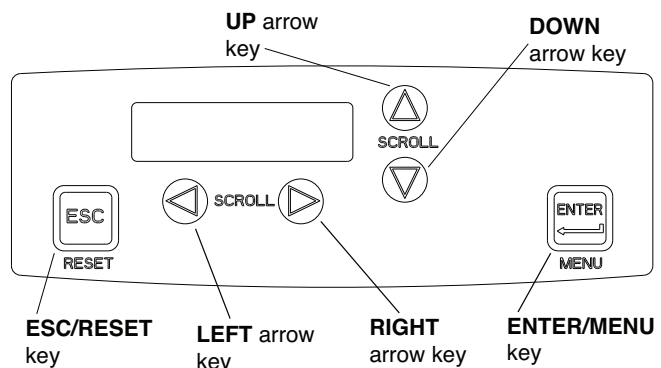

Fig. 32: Display Interface

User Menu Items

Screen No.	Default Information Displayed	Range	Description
1	Heat Loop		Cascade or heat loop setpoint
	159 °F	50-190 °F	
2	Heat Diff		Cascade or heat loop differential, below setpoint
	30 °F	1-45 °F	(Suggested setting 5° - 10°)
3	DHW Set		DHW Setpoint
	140 °F	95-180 °F	
4	DHW Diff		DHW Differential (off differential)
	5 °F	1-18 °F	
5	Temperature Unit		Temperature unit of measure
	°F	°C/F	
6	Clock Mode		Clock mode 12 or 24 hour
	MM/DD/YYYY Day 12:00:00	12/24 h	
7	Clock Hour		Set clock hour
	MM/DD/YYYY Day 12:00:00		
8	Clock Minut		Set clock minute
	MM/DD/YYYY Day 12:00:00		
9	Clock Weekday		Set day of week
	MM/DD/YYYY Day 12:00:00		
10	Clock Date Mode		Set date format
	MM/DD/YYYY Day 12:00:00		
11	Clock Year		Set date year
	MM/DD/YYYY Day 12:00:00		
12	Clock month		Set date month
	MM/DD/YYYY Day 12:00:00		
13	Clock date		Set date day
	MM/DD/YYYY Day 12:00:00		

- Press the **UP** arrow key to increase the temperature (maximum setpoint is 200°F, but should not exceed 180°F for “H” units or 160°F for “WH” units).

Status Menu

Installers are also able to check the current status of the XFyre unit parameters by pressing either the **LEFT** or **RIGHT** arrow keys during normal operation.

The status menu can have three states depending on the enabling of 0–10 VDC input and cascade master control. Each state can be selected using the **LEFT** or **RIGHT** arrow key when it is enabled.

Service Mode

This function is intended to simplify the gas valve adjustment if needed. Manifold gas pressure settings are listed in Table I on page 16. Automatic modulation does not take place when the controller is in Test Mode, only temperature limitation based on the XFyre Central Heating set point occurs. The user will be allowed to increase or decrease the fan speed by pressing either the **UP** or **DOWN** arrow keys.

To activate the service mode, press the **UP** arrow and **ENTER/MENU** keys together for 1 second. Once activated, you will see in the display **Service** and the actual fan speed. The measurement of the combustion levels should always be taken at the highest and lowest fan speed. After 10 minutes, the service mode stops automatically. To exit the service mode, press the **UP** and **DOWN** arrow keys together for 1 second.

Status Menu 1 Items

Screen No.	Default Information Displayed	Range	Description
1	Supply XXX°F	-13 to 248 °F	Heater Outlet Water Temperature
	Return XXX°F	-13 to 248 °F	Heater Inlet Water Temperature
2	CH Set 160°F	50 to 190 °F	Heater Outlet Water Setpoint for Hydronic Heating Temperature
	Supply XXX°F	-13 to 248 °F	Heater Outlet Water Temperature
3 *	Cas Set 160°F	50 to 190 °F	Cascade (System sensor) Setpoint if Master
	System XXX°F	-13 to 248 °F	System Sensor Temperature if Master and Present
4	DHW Set 140°F	95 to 180 °F	DHW Tank Setpoint
	DHW XXX°F	-13 to 248 °F	DHW Tank Temperature (if sensor present)
5	Outdoor XXX°F	-40 to 248 °F	Outdoor Air Temperature (if sensor present, otherwise off)
6	Flame 0.0 µA		Flame Ionization Signal
	Fan Speed 0 RPM		Fan RPM
7	0-10V 10.0V		Remote Setpoint or Modulation Signal
8	Bus Comm No Conn	Conn/No Conn	Cascade Bus Connection or No Connection
9	Power On 0h		Hours the Heater Has Been Powered
	CH On 0h		Hours With a Call For Heat
10	DHW On 0h		Hours With a DHW Demand
	Good Ignition 0x		Number of Successful Ignitions
11	Fault History 1/Fault Type (Last Error)		Last Fault Display Code
	MM/DD/YYYY Day 12:00:00		Time of Last Fault
12	Fault History 2/Fault Type		Fault Display Code
	MM/DD/YYYY Day 12:00:00		Time of Fault
13	Fault History 3/Fault Type		Fault Display Code
	MM/DD/YYYY Day 12:00:00		Time of Fault
14	Fault History 4/Fault Type		Fault Display Code
	MM/DD/YYYY Day 12:00:00		Time of Fault
15	Fault History 5/Fault Type		Fault Display Code
	MM/DD/YYYY Day 12:00:00		Time of Fault
16	Fault History 6/Fault Type		Fault Display Code
	MM/DD/YYYY Day 12:00:00		Time of Fault
17	Fault History 7/Fault Type		Fault Display Code
	MM/DD/YYYY Day 12:00:00		Time of Fault
18	Fault History 8/Fault Type		Fault Display Code
	MM/DD/YYYY Day 12:00:00		Time of Fault
19	Fault History 9/Fault Type		Fault Display Code
	MM/DD/YYYY Day 12:00:00		Time of Fault
20	Fault History 10/Fault Type		Fault Display Code
	MM/DD/YYYY Day 12:00:00		Time of Fault

* Screen 3 is displayed in Cascade Mode only

Status Menu 2 Items

Screen No.	Default Information Displayed	Range	Description
1	Analog DHW Temp (if active)	Temp/Fan	Analog 0-10V Input Setpoint or Fan Modulation Control
	Analog Sig. XX.X V	0-10.0V	Analog 0-10V Signal

Status Menu 3 Items

Screen No.	Default Information Displayed	Range	Description
1	Cascade Status No Follower		Cascade Status, Master or Follower, Ready or CFH (TT)
	Sys Pump Status On	On/Off	System Pump On or Off
2	Cascade Pwr XXX%	0-100%	Cascade Demand %
	Present 0XXXXXXX	0-8	Heaters Present in Cascade
3	Cascade Sys XXX °F	-13 to 248 °F	Cascade System Temperature
	Cascade Set 160 °F	50 to 190 °F	Cascade Setpoint
4	Boiler 0 XXX%	0-100%	Heater Demand %
	Boiler 1 XXX%	0-100%	Heater Demand %
5	Boiler 2 XXX%	0-100%	Heater Demand %
	Boiler 3 XXX%	0-100%	Heater Demand %
6	Boiler 4 XXX%	0-100%	Heater Demand %
	Boiler 5 XXX%	0-100%	Heater Demand %
7	Boiler 6 XXX%	0-100%	Heater Demand %
	Boiler 7 XXX%	0-100%	Heater Demand %

Installer Menu Items

Screen No.	Default Information Displayed	Range	Description
1	Operational Mode		Operational Mode of the Controller
	Hydronic		
3	DHW Tank Max (if active)		Maximum User Setting for DHW Tank Temperature
	180 °F	95 to 185 °F	Setting
6	DHW Pump Delay		DHW Pump Delay Timing
	0 Min.	0-10 Minutes	Setting
7	Outdoor Cutoff		Cutoff Temperature for Outdoor Temperature Reset Systems
	68 °F	41 to 122 °F	Setting
8	Reset Min Out		Minimum Outdoor Design Temperature
	5 °F	-49 to 32 °F	Setting
9	Reset Max Temp		Maximum Outdoor Reset Setpoint Temperature
	190 °F	77 to 190 °F	Setting
10	Reset Max Out		Maximum Outdoor Design Temperature
	68 °F	32 to 95 °F	Setting
11	Reset Min Temp		Minimum Outdoor Reset Setpoint Temperature
	95 °F	32 to 190 °F	Setting
12	Hydronic Min Temp		Hydronic Minimum Temperature
	90 °F	32 to 190 °F	Setting

Installer Menu Items (continued)

Screen No.	Default Information Displayed	Range	Description
13	Hyd Pump Delay		Heater Pump Delay Timing
	0 Min.	0-10 Minutes	Setting
14	DHW Priority		DHW Priority Timing
	30 minutes	0-60 Minutes	Setting
15	Cascade Address		Heater Cascade Address, 0 for Master, 1-7 for Followers
	0	0-8	Heater Address Setting, Do Not Use Address 8
16	0-10V		0-10V input configuration
	DHW Thermistor		Direct/DHW Thermistor/OFF/Boosterboard
17	0-10V Mode		Mode Selection for 0-10V Direct Input Operation
	Temperature		Temperature (Setpoint) or Fan Speed (Firing Rate)
18	Step Modulation		Enable or Disable Step Modulation
	ON	ON/OFF	Setting
19	Temp to Indirect		Heater Output Setpoint for Indirect Operation
	180 °F	140 to 190 °F	Setting
20	WPS Input		Factory Configured, DO NOT CHANGE
	Flow Switch		Low Water Cutoff/Flow Switch/Water Pressure/None
21	Error Outd Sensor		Enable Outdoor Sensor Error Reporting
	OFF	ON/OFF	Setting
22	Max Fan Speed		Allows Reduction of Maximum Input Rate
	100%	50-100%	Setting
23	Cascade Config		Cascade or Non-Cascade Operation
	OFF/VIS 3	All 926/OFF	All 926 for Single or Multi-Heater Cascade
24	Cascade Rotation		Lead Boiler Rotation Time
	24 Hours	0-240 Hours	Setting
25	Cascade DHW Conf		
	DHW Entire Cascade		DHW Entire Cascade/DHW Master Only
26	System Pump Freeze		Enable System Pump (if cascade master and controlling system pump) When Outdoor Temp Drops Below Setpoint
	Protect OFF	OFF to 104 °F	
27	Sys Sense Fault		Enable System Sensor Error Reporting
	ON	ON/OFF	Setting
28	Freeze Protect		Heater Freeze Protection, Enable Heater Pump at Return Temps below 44°F, Fires Heater if Temps Drop Below 37°F
	ON	ON/OFF	
29	DHW Demand Start		Max for Normal DHW Operation, Min for Low Fire Start DHW
	Maximum	Maximum/Minimum	
30	Extra Boiler		Off if No Extra Boiler, 100 for Extra On/Off Boiler
	OFF	OFF/50-100	Setting
31	Sing Boil Casc		Enable Single Boiler Cascade for Single Boiler Primary/Secondary Operation with a System Sensor
	OFF	ON/OFF	
32	Maintenance Inter		Installers Only - Enable Maintenance Mode Alarm by Date or Running Hours
	OFF	OFF/RH/Date	

Installer Menu

The installer menu consists of several items that can be adjusted. To access the installer menu, press and hold the **ENTER/MENU** key for 5 seconds. Using the **UP** and **DOWN**, and **LEFT** and **RIGHT** arrow keys, enter **925**, then press **ENTER/MENU**. Scroll through the list of adjustable items by pressing the **LEFT** or **RIGHT** arrow keys. Once the desired item is displayed, press the **ENTER/MENU** key to select it. The screen will begin to flash. Press the **DOWN** arrow key to decrease the values, and the **UP** arrow key to increase them. To store the changes, press the **ENTER/MENU** key. The display returns to normal mode after one minute. Pressing the **ESC/RESET** key before storing changes will restore the original value.

The central heating demand is detected when the room thermostat closes. When an outside sensor is also connected, the supply temperature will depend on the factory default central heating curve which is sufficient for most applications.

To set your own custom heat curve you will have to set the following parameters. Use the graphs in Figs. 33 and 34 to assist you in the design of the curve.

1. Minimum outside design temperature: **Function 8**
2. Design Supply water temperature at the minimum design outside temperature: **Function 9**
3. Maximum outside design temperature: **Function 10**
4. Design Supply Water Temperature at the maximum outside temperature: **Function 11**

NOTE: It is important to note that the user can adjust the heat curve down by adjusting the central heating temperature to a lower setting.

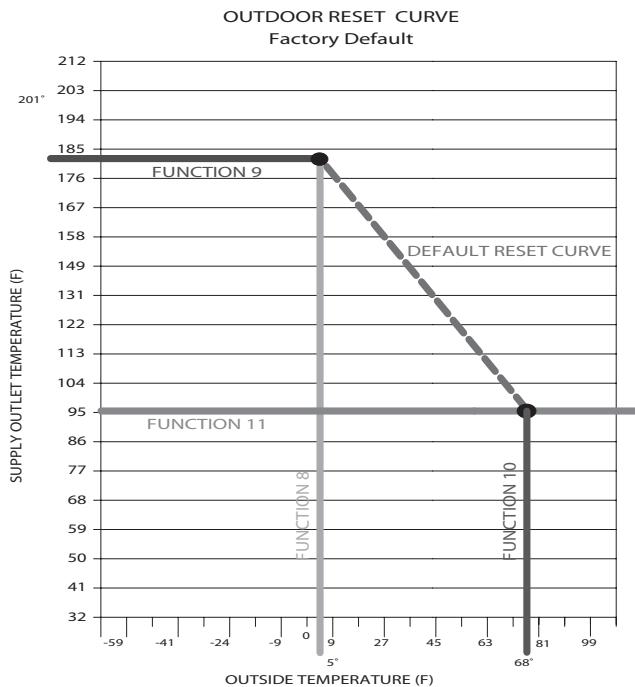

Fig. 33: Outdoor Reset Curve — Factory Default

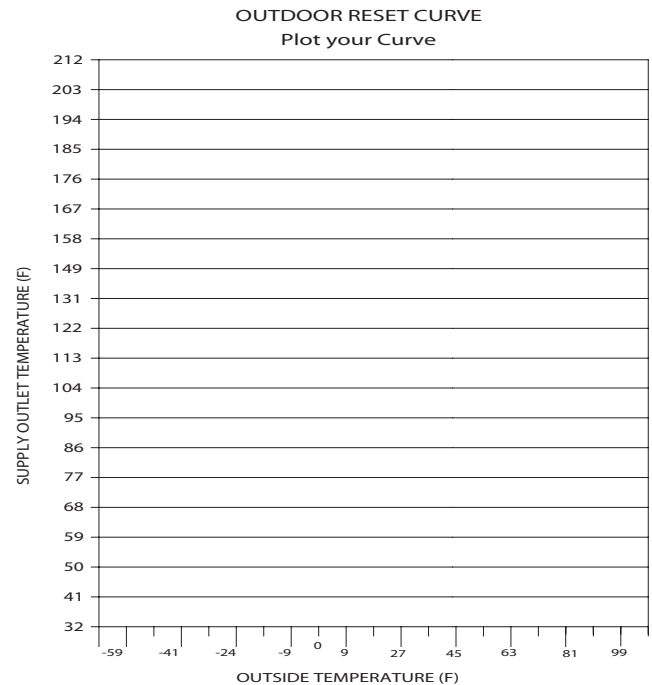

Fig. 34: Outdoor Reset Curve — Plot Your Curve

NOTE: The wiring diagrams in this manual show all standard options. Refer to the large wiring diagram provided with your boiler for options installed on your specific unit(s).

START-UP

Pre Start-up

Filling System (Heating Boilers)

Fill system with water. Purge all air from the system. Lower system pressure. Open valves for normal system operation, and fill system through feed pressure. Manually open air vent on the compression tank until water appears, then close vent.

Air Purge (Domestic Hot Water Heaters)

CAUTION: An air vent should be installed at the highest point in the system for proper operation. If water piping is located higher than the boiler, it should be relocated to the highest point in the installed system.

Purge all air from system before lighting heater. This can be normally accomplished by opening a downstream valve.

Venting System Inspection

1. Check all vent pipe connections and flue pipe material.

WARNING: If you do not follow these instructions exactly, a fire or explosion may result causing property damage, personal injury or loss of life.

2. Make sure vent terminations are installed per code and are clear of all debris or blockage.

For Your Safety

This appliance has a direct spark igniter. It is equipped with an ignition device which automatically lights the burners. Do not try to light the burners by hand.

BEFORE OPERATING, smell all around the appliance area for gas. Be sure to smell near the floor because some gas is heavier than air and will settle on the floor.

WHAT TO DO IF YOU SMELL GAS:

- Do not try to light any appliance.
- Do not touch any electrical switch; do not use any telephone in your building.
- Immediately call your gas supplier from a neighbor's telephone. Follow the gas supplier's instructions.
- If you cannot reach your gas supplier, call the fire department.
- Use only your hand to push in or turn the gas control knob. Never use tools. If the knob will not turn by hand, do not try to repair it, call a qualified service technician. Forced or attempted repair may result in a fire or explosion.
- Do not use this appliance if any part has been under water, immediately call a qualified service technician to inspect the appliance and to replace any part of the control system and any gas control which has been under water.
- Check around unit for debris and remove combustible products, i.e. gasoline, etc.

Pre Start-up Check

1. Verify the heater is filled with water.
2. Check system piping for leaks. If found, repair immediately.
3. Vent air from system. Air in system can interfere with water circulation.
4. Purge air from gas line to boiler.

Initial Start-up

Required tools

- (1) 12-0-12 (24" scale) U-tube manometer
- (2) 6-0-6 (12" scale) U-tube manometer
- Screwdrivers (assorted sizes and shapes)
- (1) Crescent wrench (8" or 10")
- (1) Multi-meter

(Metric Allen wrenches will be required for servicing the gas valve, but not during start-up)

NOTE: Digital manometers are not recommended.

Preparation

WARNING: Do not turn on gas at this time.

Check Power Supply

With multi-meter at incoming power, check voltage between:

Hot - Common (≈ 120 VAC)

Hot - Ground (≈ 120 VAC)

Common - Ground (< 1 VAC)

WARNING: If Common - Ground is > 1 VAC, STOP: Contact electrician to correct ground failure. Failure to do this may burn out 120V-24V transformer, or may cause other safety control damage or failure.

Attach Manometers to Measure Pressures

1. Turn off main gas valve.
2. On the 700 and 850 models, remove plugs "A" and "B," and install 1/8" NPT fittings to allow measurement of the gas pressure.
3. Attach (1) 12" scale manometer to the upstream fitting on the gas supply pipe to the heater (Measure point "A" in Fig. 35. Field-supplied on the 700 and 850 models).

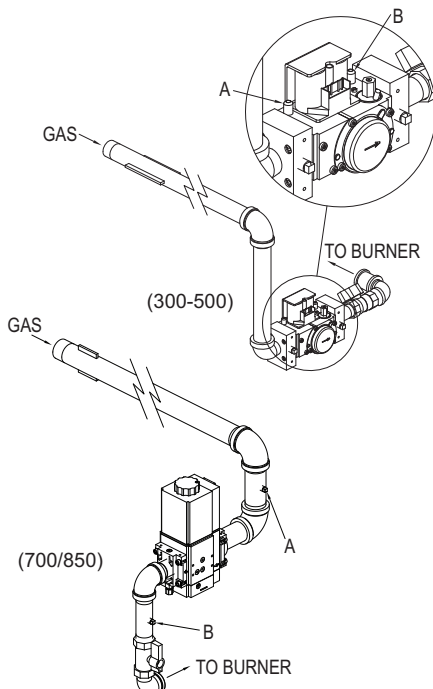

Fig. 35: Gas Pressure Measurement Locations

4. Attach (1) 12" scale manometer to the downstream fitting on the gas manifold (Measure point "B" in Fig. 35. Field-supplied on the 700 and 850 models).
5. Attach (1) 12" scale manometer to the tapping on the filter box. Pull black cap from air pressure switch tee and connect the manometer. NOTE: Retain caps for reinstallation later.

Check Gas Supply Pressure

1. Slowly turn on main gas shut-off valve.
2. Read the gas supply pressure from the manometer; minimum supply pressure for natural gas is 4.0 in. WC, recommended supply is 7.0 in. WC, minimum supply pressure for propane gas is 4.0 in. WC, recommended supply is 11.0 in. WC (dynamic readings, full fire input).
3. If the gas pressure is greater than 14.0 in. WC, turn off the main gas shut-off valve.

Start-Up

1. Turn power on.
2. Turn on the boiler, approximately 5 seconds after the blower starts, the igniter should start to spark (observable through the observation port located at the front, bottom of the boiler) and the gas valve will open. Look into the sight glass located at the bottom of the front panel to check igniter operation.
3. The boiler ignites at 3000 RPM (as indicated on the LCD display of the user interface).
4. This boiler is equipped with a standard four-try ignition module, it will try for ignition up to four times before going into lockout. If the boiler is equipped with the optional single-try ignition module, it will try for ignition one time before going into lockout.
5. Wait until the controller indicates 100% on the firing rate display screen. This will take several minutes if step modulation is enabled.

Blower Check

1. Check the high and low fire fan speed on the user-interface. Enter the service mode by pressing the **UP** arrow key and **ENTER/MENU** key simultaneously for 1 second. Verify that the min. and max. fan speeds match Table R on the following page.
2. Note the high fire air intake pressure on the filter box and compare to Table Q. Excessively high pressures indicate an obstruction in the air intake or undersized/too long air intake ducting. With a clean air filter in place, record the intake air pressure setting on the start-up checklist. Replace the filter when the intake air pressure increases by -0.5 in. WC from the reading recorded on the start-up checklist.
3. The desired combustion CO₂ is between 8.5% and 9.0% for natural gas, and between 9.0% and 9.5% for propane with CO less than 150 ppm. Combustion should be checked at high and low fire (Max. and Min. fan speed) by using the service mode. Enter the service mode by pressing the **UP** arrow key and **ENTER/MENU** key simultaneously for 1 second. Set the fan speed using the **UP** and **DOWN** arrow keys.

Manifold Check

1. Check manifold gas pressure at the manifold pressure tap (connection "B" in Fig. 35). This pressure should read per the values in Table S for natural and propane gas.
2. If the pressure reading differs by more than ± 0.2 in. WC, **STOP – Call the factory for directions on what to do next!**

Model	Air Pressure Setting (in. WC)	Setting Tolerance
300	-0.1	± 0.2 in. WC
400	-0.2	± 0.2 in. WC
500	-0.2	± 0.2 in. WC
700	-0.2	± 0.2 in. WC
850	-0.3	± 0.2 in. WC

Table Q: XFyre Intake Air Pressure Settings (High Fire)

Model	High Fire	Ignition	Low Fire
300	5000	3000	1500
400	6000	3000	1250
500	7600	3000	1750
700	4600	3000	1250
850	5500	3000	1500

Table R: XFyre Fan Speed Settings

Model No.	Manifold Pressure (in. WC)			
	Natural Gas		Propane Gas	
	High	Low	High	Low
300	-0.2	-0.1	-0.2	-0.1
400	-0.2	-0.1	-0.2	-0.1
500	-0.4	-0.1	-0.4	-0.1
700	-1.5	-0.2	-2.2	-0.2
850	-2.7	-0.2	-1.6	-0.1

NOTE: Manifold pressures should be ± 0.3 in. WC.

Table S: XFyre Manifold Pressure Settings

CAUTION: Special manifold and air settings may be required.

Finishing

1. Record all data on the "Start-up Checklist" located at the back of this manual.
2. Disconnect the manometers and reconnect the cap on the air intake and reinsert or close the sealing screws into the bleedle valves.
3. Start-up is complete and the boiler should be operating properly.

Safety Inspection

1. Check all thermostats and high limit settings.
2. During the following safety checks leave manometers hooked up, check and record.
3. If other gas-fired appliances in the room are on the same gas main, check all pressures on the XFyre with all other equipment running.
4. Check thermostats for ON-OFF operation.
5. Check high limits for ON-OFF operation.
6. While in operation, check flow switch operation.

-
7. Check the low gas pressure switch (if provided). (For proper adjustment, use the attached manometers, if available, to set pressure. The scales on the switch are approximate only.) Low gas pressure switch (if provided) must be set at 3.0 in. WC for natural gas and propane gas.
 8. Make sure that the high gas pressure switch (optional) is set to 3.0 in. WC for both natural gas and propane gas.
 8. Check to see that the high limit control is set above the design temperature requirements of the system. For multiple zones: Check to make sure the flow is adjusted as required in each zone.
 9. Check that the boiler is cycled with the thermostat. Raise the setting on the thermostat to the highest setting and verify that the boiler goes through the normal start-up cycle. Reduce to the lowest setting and verify that the boiler goes off.

Follow-Up

Safety checks must be recorded as performed.
Turn boiler on. After main burner ignition:

1. Check manometer for proper readings. Specifically note the change in air intake pressure. Replace the filter if necessary. (Refer to Table Q.)
2. Cycle unit several times and re-check readings.
3. Remove all manometers and replace caps and screws.
4. Check for gas leaks one more time.

Post Start-Up Check

Check off steps as completed:

1. Verify that the boiler and heat distribution units or storage tank are filled with water.
2. Confirm that the automatic air vent (if used) was opened two full turns during the venting procedure.
3. Verify that air has been purged from the system.
4. Verify that air has been purged from the gas piping, and that the piping has been checked for leaks.
5. Confirm that the proper start-up procedures were followed.
6. Inspect burner to verify flame.
7. Test safety controls: If boiler is equipped with a low water cut-off or additional safety controls, test for operation as outlined by manufacturer. Burner should be operating and should go off when controls are tested. When safety devices are restored, burners should re-ignite after pre-purge time delay.

10. Observe several operating cycles for proper operation.
11. Set the boiler thermostat to desired temperature.
12. Review all instructions shipped with this boiler with owner or maintenance person, return to envelope and give to owner or place the instructions inside front panel on boiler.

OPERATION

Lighting Instructions

1. Before lighting, make sure you have read all of the safety information in this manual.
2. Set the thermostat to the lowest setting.
3. Turn off all electrical power to the appliance.
4. This appliance is equipped with an ignition device which automatically lights the burner. Do not try to light the burner by hand.
5. Turn on main manual gas valve field-installed near gas inlet connection on back of boiler.
6. Wait 5 minutes to clear out any gas. Then smell for gas, especially near the floor. If you then smell gas, STOP! Follow the steps in the safety information on the front cover of this manual. If you do not smell gas, go to next step.
7. Turn on all electrical power to the appliance.
8. Set thermostat to desired setting. The appliance will operate. The igniter will spark after the pre-purge time delay (15 seconds). The main valve should open. System will try for ignition up to four times (one time on optional single-try ignition module). If flame is not sensed, lockout will commence.

-
9. If the appliance will not operate, follow the instructions “To Turn Off Gas To Appliance,” and call your service technician or gas supplier.
 10. If boiler fails to start, verify the following:
 - a. There are no loose connections or that the service switch is off.
 - b. High temperature limit switch or manual-reset high limit is not tripped.
 - c. Thermostat is set above water temperature.
 - d. Gas is on at the meter and the boiler.
 - e. Incoming dynamic gas pressure to the gas valve is NOT less than 4.0 in. WC for natural gas or propane gas.

To Turn Off Gas To Appliance

1. Shut off manual gas valve field installed near gas inlet connection on back of boiler.
2. Set the thermostat to lowest setting.
3. Turn off all electrical power to the appliance if service is to be performed.

TROUBLESHOOTING

XFyre Error Codes

If any of the sensors detect an abnormal condition or an internal component fails during the operation of the XFyre, the display may show an error code. This code may either be the result of a temporary condition in which case the display will revert to its normal readout when the condition is corrected, or it may be the result of a condition that the controller has evaluated as not safe to restart the unit. In this case, the unit control will be locked out, requiring the maintenance person to manually reset the control by pressing the **ESC/RESET** key for more than 1 second. Typically, if the display has a code beginning with F followed by 2 numbers the XFyre is locked out. If the display has a 3 letter code it is the result of a temporary condition.

Heater Errors

When an error condition occurs, the controller will display an error code on the display module. These error codes and several suggested corrective actions are included in the XFyre Fault Text section on the following page.

Heater Faults

1. When a fault condition occurs, the controller will illuminate the red “fault” indication light and display a fault code in the format. The alarm output will also be activated. Most fault conditions will also cause the boiler pump to run in an attempt to cool the unit.
2. Note the fault text and refer to the XFyre Fault Text section for an explanation of the fault along with several suggestions for corrective actions.
3. Press the **ESC/RESET** key to clear the fault and resume operation. Be sure to observe the operation of the unit for a period of time to ensure correct operation and no reoccurrence of fault codes.

DANGER: When servicing or replacing components that are in direct contact with the water, be certain that:

- There is no pressure in the boiler. (Pull the release on the relief valve. Do not depend on the pressure gauge reading).
- The boiler water is not hot.
- The electrical power is off.

WARNING: When servicing or replacing any components of this unit be certain that:

- The gas is off.
- All electrical power is disconnected.

CAUTION: Label all wires prior to disconnection when servicing controls. Wiring errors can cause improper and dangerous operation. Verify proper operation after servicing.

WARNING: Do not use this appliance if any part has been under water. Improper or dangerous operation may result. Contact a qualified service technician to inspect the boiler and to repair or replace any part of the boiler that has been under water prior to placing the boiler back in operation.

CAUTION: If overheating occurs or the gas supply fails to shut off, do not turn off electrical power to the circulating pump. This may aggravate the problem and increase the likelihood of boiler damage. Instead, shut off the gas supply to the boiler at the gas service valve.

NOTE: The onboard fault history only records faults that lock out the system (FXX faults).

XFyre Fault Text

Error Text	Remedy
OUTDOOR SENSOR FOU (Displays only if Screen 21 of the Installer Menu is ON)	Inspect wiring from outside sensor for damage or shorted connections repairing as necessary. Measure resistance of outdoor sensor and compare to resistance chart on page 48. If not within range on chart, shorted or open, replace sensor.
LINE VOLTAGE E19	Inspect power wiring to boiler and repair as necessary. If connected to line voltage, notify power company. If connected to alternate power source such as generator or inverter, make sure line voltage frequency supplied by the device is 60 Hz.
BLOCKED VENT FLU	<ol style="list-style-type: none"> 1. Ensure that the flue is not blocked. 2. Check the switch wiring by applying a jumper in place of the switch. If the code clears with the jumper in place REPLACE the flue switch and connect the wires to the new switch before running the unit. <p>WARNING: Do not use the jumper to remedy this error. A faulty switch MUST be replaced. Failure to do so could result in serious injury or death.</p>
LOW WATER LEVEL LEO	<ol style="list-style-type: none"> 1. Check boiler feed water system to be sure it is supplying make up water to boiler system. 2. Make sure all air is bled from the system. 3. Check for leaks in boiler and system piping and repair as necessary. 4. Inspect low level switch and wiring for damage and repair as necessary.
24 VOLT LOW LOU	<ol style="list-style-type: none"> 1. Check line voltage. Must be between 100–128 VAC. 2. If available, connect PC and using service software check the 24 VAC supply display in the lower left corner of the screen. The number displayed here must be greater than 128 and should be greater than 250. Use this as a troubleshooting guide as you follow the steps below. 3. Remove 10-pin Molex connector from customer connection board. If LOU code clears, then the problem is with external sensor wiring. Examine external sensor wiring for shorts to ground repairing as necessary. If LOU code is still present and the boiler is so equipped, disconnect high gas pressure switch, then low gas pressure switch, then UL 353 low water cutoff in this order one at a time to see if LOU code clears. Replace faulty part. Check low voltage wire harness in boiler for shorts. 4. If LOU only occurs when burner tries to light, check gas valve for excessive current draw. 5. If LOU is present with the low voltage harness disconnected from the control board, replace the control board.
LOW WATER FLOW PRIO (if unit is operating) or TEMPER BLOCKING (if Flow Switch is OFF)	<ol style="list-style-type: none"> 1. Check to see if boiler circulator is functioning. Repair as necessary. 2. Make sure water is flowing in the system. Check for valves that should be open, plugged filter screens, etc. 3. Check flow switch and wiring. Repair as necessary. 4. TEMPER BLOCKING can indicate a normal condition such as setpoint achieved but still within the differential.
HIGH TEMPERATURE F00	<ol style="list-style-type: none"> 1. Check circulation pump operation. 2. Ensure that there is adequate flow through the boiler by accessing the status menu. Make sure that there is less than a 50°F rise from the return sensor to the supply sensor. 3. Check sensor reading on supply sensor. Replace sensor if faulty. 4. If this is a new installation, disconnect the two TT wires from the zone control, and connect the wires together. <p>Depress the ESC/RESET button. If the fault clears, the problem is outside the boiler.</p>

Error Text	Remedy
FLUE / GAS PRESS F01	<ol style="list-style-type: none"> 1. If the boiler is equipped with high and/or low gas pressure switches, examine the switch(es) to see if the yellow LED is illuminated on the switch. If so, correct the gas supply problem associated with the switch and reset the switch by pressing on the cover of the switch over the red button. Pressing the button requires a firm push. Push the reset button on the front panel of the boiler to reset the boiler control. 2. If the boiler has a UL353 LWCO, check to see if the red LED on the LWCO control box is illuminated. If so, correct the low water condition and press the reset button on the LWCO control box to reset the LWCO. The LED should change to green. Press the reset button on the front panel of the boiler to reset the boiler control. 3. Check the flue for obstructions or any sign of damage especially signs of excessive heat. Repair as necessary. Push the red reset button on the flue temperature switch located on the flue, under the rear access panel of the boiler. NOTE: Switch temperature must be less than 90°F to reset. Run the boiler and check the flue temperature. If the flue temperature is within specs and the switch trips, replace the switch. If the flue temperature is excessive check and adjust combustion controls on the boiler. If problem persists, inspect the target wall in the combustion chamber and replace it if cracked or damaged.
SUPPLY THERMISTR F02	<ol style="list-style-type: none"> 1. Check the electrical connection to the sensor on the outlet manifold. Verify 5 VDC by checking the Molex connector. If no 5 VDC, check the harness. If the harness is OK, replace the control. Press the reset button on the front panel of the boiler to reset the boiler control. Verify sensor values by referencing chart on page 48. 2. Replace sensor if necessary.
RETURN THERMISTR F03	<ol style="list-style-type: none"> 1. Check the electrical connection to the sensor on the inlet manifold. Verify 5 VDC by checking the Molex connector. If no 5 VDC, check the harness. If the harness is OK, replace the control. Press the reset button on the front panel of the boiler to reset the boiler control. Verify sensor values by referencing chart on page 48. 2. Replace sensor if necessary.
SUPPLY HIGH F05	<ol style="list-style-type: none"> 1. Check circulation pump operation. 2. Ensure that there is adequate flow through the boiler by accessing the status menu and assuring that there is less than a 50°F rise from the return sensor to the supply sensor. 3. Troubleshoot the sensor by following steps in SUPPLY THERMISTR F02.
IGNITION FAILURE F09	<ol style="list-style-type: none"> 1. Watch the igniter through the observation port. 2. If there is no spark, check the spark electrode for the proper 1/4" gap. Use 2 quarters together as a gauge to hold igniter against to check gap distance. 3. Remove any corrosion from the electrode and flame sensing rod. 4. If there is a spark but no flame, check the gas supply to the boiler. 5. If there is a flame, check the flame sensor. 6. Check any flue blockage or condensate blocks.
FLAME FAILURE F10	<ol style="list-style-type: none"> 1. Monitor the gas pressure to the unit while in operation. 2. Ensure that the flame is stable when lit. 3. Check to see if the green light on the display module is out while the boiler is running. 4. If the green light doesn't come on or go off during operation check the flame signal on the status menu. 5. If the signal reads less than 1 microampere, clean the flame sensing rod. 6. If the flame sensing rod continues to read low, replace it. 7. Check the stability of the flame rectification signal. If the signal is unstable, you may need to replace the burner gasket.
FLAME WHEN OFF F11	<ol style="list-style-type: none"> 1. Look into viewing port. If there is a flame, turn the gas off to the unit at the service valve and replace gas valve. 2. If the flame signal is present and there is no flame, replace the flame sensing rod. 3. If the flame signal is not present after turning off the gas supply, check the gas valve electrical connection. 4. Remove the valve and check for obstruction in the valve seat or replace the gas valve. 5. Turn the gas on at the service valve after corrective action is taken. 6. Check for condensate back up. Condensate back up can damage the refractory wall, and if the wall falls against the flame rod, it may conduct the signal to ground, giving a false reading.
FAN SPEED ERROR F13	<ol style="list-style-type: none"> 1. Check the combustion air fan wiring. 2. Check the 24 VAC signal by measuring from any connected safety to ground. A low voltage situation may cause a "false" error code. 3. Replace the combustion air fan. 4. Replace the control board.
CONDENSATE FULL HIO	<ol style="list-style-type: none"> 1. Check condensate lines for obstructions. 2. Check float switch in condensate reservoir. 3. Check wiring from condensate reservoir to control board and repair as necessary.
PROGRAMMED PP	Press ESC/RESET for at least 1 second.
MEMORY ERROR F31	Control must be re-programmed. If programming does not solve problem, control must be replaced.

Sensor Resistance Values

Temperature Sensors	
Water Temperature (°F)	Resistance (ohms)
32	32550
41	25340
50	19870
59	15700
68	12490
77	10000
86	8059
95	6535
104	5330
113	4372
122	3605
131	2989
140	2490
149	2084
158	1753
167	1481
176	1256
185	1070
194	915
203	786
212	667

Outdoor Sensor	
Water Temperature (°F)	Resistance (ohms)
-22	171800
-13	129800
-4	98930
5	76020
14	58880
23	45950
32	36130
41	28600
50	22800
59	18300
68	14770
77	12000
86	9804
95	8054
104	6652
113	5522

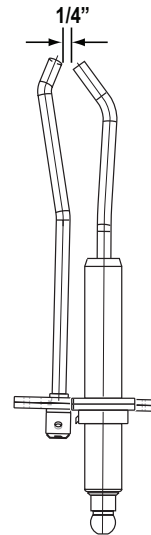

NOTE: If receiving a NO FLAME F09 fault code, check the gap spacing between points on the electrode by holding two quarters together and sliding them through the gap. There should be a slight resistance.

Fig. 36: Direct Spark Igniter

MAINTENANCE

Suggested Minimum Maintenance Schedule

Regular service by a qualified service agency and maintenance must be performed to ensure maximum operating efficiency.

Maintenance as outlined below may be performed by the owner.

Daily

1. Check that the area where the boiler is installed is free from combustible materials, gasoline, and other flammable vapors and liquids.
2. Check for and remove any obstruction to the flow of combustion or ventilation air to boiler.

Monthly

1. Check for piping leaks around pumps, mixing valves, relief valves, and other fittings. If found, repair at once. DO NOT use petroleum-based stop-leak compounds.
2. Visually inspect burner flame.
3. Visually inspect venting system for proper function, deterioration or leakage.
4. Visually inspect for proper operation of the condensate drains in the venting, and the internal condensate trap. Clean trap as necessary. If leaks are observed, repair at once.
5. Check air vents for leakage.

Yearly (Beginning Of Each Heating Season)

Schedule annual service call by qualified service agency.

1. Visually check top of vent for soot. Call service person to clean. Some sediment at bottom of vent is normal.
2. Visually inspect venting system for proper function, deterioration or leakage. Ensure that condensate drain is inspected and ensure that

condensate is being directed to appropriate condensate management system or drain, as required by local codes.

3. Check that area is free from combustible materials, gasoline, and other flammable vapors and liquids.
4. Check for and remove any obstruction to the flow of combustion or ventilation air to boiler.
5. Follow pre-start-up check in the Start-up section.
6. Visually inspect burner flame. It should be light blue at full input. Remove and visually inspect direct spark igniter and sensor for damage, cracking or debris build-up.
7. Check operation of safety devices. Refer to manufacturers' instructions.
8. Follow oil-lubricating instructions on pump (if required). Over-oiling will damage pump. Water-lubricated circulators do not need oiling.
9. To avoid potential of severe burn, DO NOT REST HANDS ON OR GRASP PIPES. Use a light touch; return piping will heat up quickly.
10. Check blower and blower motor.
11. Check for piping leaks around pumps, relief valves and other fittings. Repair, if found. DO NOT use petroleum-based stop-leak.

Periodically

1. Check relief valve. Refer to manufacturer's instructions on valve.
2. Test low water cut-off (if equipped). Refer to manufacturer's instructions.

Preventive Maintenance Schedule

The following procedures are recommended and are good practice for all XFire installations.

Daily

1. Check gauges, monitors and indicators.
2. Check instrument and equipment settings. (See "Post Start-Up Check".)

-
3. Check burner flame. (Should see light blue flame at full input rate).

Reset to original setting after each device is tested.

Weekly

For low-pressure boilers, test low-water cut-off device. (With boiler in pre-purge, depress the low water cut-off test button. Appliance should shut-off and ignition fault light should come on. Depress reset button on front of heater control panel to reset).

Monthly

1. Check flue, vent, stack, or outlet dampers.
2. Test intake air pressure. (See Table Q.) Replace the filter when the intake air pressure increases by -0.5 in. WC from the reading recorded on the start-up checklist.
3. Test high and low gas pressure interlocks (if equipped). (See "Safety Inspection".)

Semi-Annually

1. Recalibrate all indicating and recording gauges.
2. Check flame failure detection system components.
3. Check firing rate control by checking the manifold pressure. (See "Manifold Check".)
4. Check piping and wiring of all interlocks and shut-off valves.

Annually

1. Test flame failure detection system and pilot turn-down.
2. Test high limit and operating temperature. (See "Post Start-Up Check".)
3. Check flame sensor.
4. Conduct a combustion test at high and low fire. Carbon dioxide should be 8.5 to 9.0% at full fire for natural gas, and between 9.0 to 9.5% for propane gas. Carbon monoxide should be <150 ppm.
5. Check valve coil for 60 cycle hum or buzz. Check for leaks at all valve fittings using a soapy water solution (while unit is operating). Test other operating parts of all safety shut-off and control valves and increase or decrease settings (depending on the type of control) until the safety circuit opens.

6. Perform leakage test on gas valves.
7. Test air switch in accordance with manufacturer's instructions. (Turn panel switch to the "On" position until blower is proven, then turn the switch to "Off".)
8. Inspect and clean burner using shop air.
9. Clean the combustion chamber coil, using the procedure on the following page.

As Required

1. Recondition or replace low water cut-off device (if equipped).
2. Check drip leg and gas strainers.
3. Check flame failure detection system. (See "Post Start-Up Check".) Verify high and low fire flame signal, compare to start-up data,
4. Check igniter. Clean and verify spark gap (see Fig. 36).
5. Check fan speed and manifold pressure. (See "Blower Check" and "Manifold Check".)
6. Test safety/safety relief valves in accordance with ASME Heater and Pressure Vessel Code Section IV.

WARNING:

The combustion chamber insulation in this product contains ceramic fiber material. Ceramic fibers can be converted to cristobalite in very high temperature applications. The International Agency for Research on Cancer (IARC) has concluded that “Crystalline silica inhaled in the form of quartz or cristobalite from occupational sources is carcinogenic to humans (Group1).”:

- Avoid breathing dust and contact with skin and eyes.

- Use NIOSH certified dust respirator (N95). This type of respirator is based on the OSHA requirements for cristobalite at the time this document was written. Other types of respirators may be needed depending on the job site conditions. Current NIOSH recommendations can be found on the NIOSH website at

<http://www.cdc.gov/niosh/homepage.html>.

NIOSH approved respirators, manufacturers, and phone numbers are also listed on this website.

- Wear long-sleeved, loose fitting clothing, gloves, and eye protection.

- Apply enough water to the combustion chamber lining to prevent dust

- Wash potentially contaminated clothes separately from other clothing. Rinse clothes washer thoroughly.

NIOSH stated First Aid:

Eye: Irrigate immediately

Breathing: Fresh air.

Combustion Chamber Coil Cleaning Instructions

Before beginning this procedure, you must have on hand the following items:

- a nylon, stainless steel or brass brush (not steel)
- “Rydlyme” (recommended for best results) or “CLR”
- Gloves, eye protection

1. Shut down the XFyre boiler by using the following steps:

- a. Close the gas valve, shut down the unit and wait for the unit to be cool to the touch.
- b. Disconnect the condensate piping from the outside connection, (not from the XFyre boiler side), so the flow from condensate reservoir can be observed.
- c. Disconnect electrical connections from the gas valve, spark electrode and flame rectification probe and combustion blower.
- d. Remove the (4) screws on the aluminum $\frac{3}{4}$ ” NPT connector on the right side of the gas valve.
- e. Disconnect the wiring connected to the combustion blower motor.
- f. Remove the (6) 10mm nuts from the burner plate assembly.
- g. Pull the entire burner plate assembly (with blower still attached) towards you, while removing or pushing aside any wiring to allow the removal of the assembly.

2. Using a spray bottle filled with the recommended product “RYDLYME” or “CLR”, spray liberally on the coils, making sure the solution penetrates and funnels down through the condensate system. If the condensate system is blocked, let the chemical penetrate for at least 15 minutes or until it drains.

3. Use the nylon, stainless steel or brass brush (do not use steel) to scrub coils to remove any buildup, then vacuum the debris from the coils. **Be sure to follow the precautions listed for working with ceramic fibers.**

4. Spray the coils with clear water, making sure to confine the spray to the area being cleaned (**DO NOT get the back ceramic wall of the unit wet**). Flush the combustion chamber with fresh water until clear water runs from the condensate drain. At this point, the XFyre should be ready to be re-assembled.

- a. Inspect gaskets.
- b. Re-install the burner assembly.

APPENDIX

Inside Air Contamination

Combustion air can be contaminated by certain vapors in the air which raise the acidity of the condensate. Higher acidity levels attack many materials including stainless steel, which is commonly used in high efficiency systems. The boiler can be supplied with corrosion-resistant, non-metallic intake air vent material. You may, however, choose to use outside combustion air for one or more of these reasons:

1. Installation is in an area containing contaminants listed below which will induce acidic condensation.
2. You want to reduce infiltration into your building through openings around windows and doors.
3. You are using AL29-4C stainless steel vent pipe, which is more corrosion-resistant than standard metallic vent pipe. In extremely contaminated areas, this may also experience deterioration.

Products causing contaminated combustion air:

- spray cans containing chloro/fluorocarbons
- permanent wave solutions
- chlorinated waxes/cleaners
- chlorine-based swimming pool chemicals
- calcium chloride used for thawing
- sodium chloride used for water softening
- refrigerant leaks
- paint or varnish removers
- hydrochloric acid/muriatic acid
- cements and glues
- antistatic fabric softeners used in clothes dryers
- chloride-type bleaches, detergents, and cleaning solvents found in household laundry rooms
- adhesives used to fasten building products
- similar products

Areas where contaminated combustion air commonly exists:

- dry cleaning/laundry areas
- metal fabrication plants
- beauty shops
- refrigeration repair shops
- photo processing plants
- auto body shops
- plastic manufacturing plants
- furniture refinishing areas and establishments
- new building construction
- remodeling areas
- open pit skimmers

Check for areas and products listed above before installing heater. If found:

- remove products permanently, OR
- install TruSeal direct vent.

Important Instructions for the Commonwealth of Massachusetts

The Commonwealth of Massachusetts requires compliance with regulation 248 CMR 4.00 and 5.00 for installation of through – the – wall vented gas appliances as follows:

(a) For all side wall horizontally vented gas fueled equipment installed in every dwelling, building or structure used in whole or in part for residential purposes, including those owned or operated by the Commonwealth and where the side wall exhaust vent termination is less than seven (7) feet above finished grade in the area of the venting, including but not limited to decks and porches, the following requirements shall be satisfied:

1. **INSTALLATION OF CARBON MONOXIDE DETECTORS.** At the time of installation of the side wall horizontal vented gas fueled equipment, the installing plumber or gasfitter shall observe that a hard wired carbon monoxide detector with an alarm and battery back-up is installed on the floor level where the gas equipment is to be installed. In addition, the installing plumber or gasfitter shall observe that a battery operated or hard wired carbon monoxide detector with an alarm is installed on each additional level of the dwelling, building or structure served by the side wall horizontal vented gas fueled equipment. It shall be the responsibility of the property owner to secure the services of qualified licensed professionals for the installation of hard wired carbon monoxide detectors

a. In the event that the side wall horizontally vented gas fueled equipment is installed in a crawl space or an attic, the hard wired carbon monoxide detector with alarm and battery back-up may be installed on the next adjacent floor level.

b. In the event that the requirements of this subdivision can not be met at the time of completion of installation, the owner shall have a period of thirty (30) days to comply with the above requirements; provided, however, that during said thirty (30) day period, a battery operated carbon monoxide detector with an alarm shall be installed.

2. **APPROVED CARBON MONOXIDE DETECTORS.** Each carbon monoxide detector as required in accordance with the above provisions shall comply with NFPA 720 and be ANSI/UL 2034 listed and IAS certified.

3. **SIGNAGE.** A metal or plastic identification plate shall be permanently mounted to the exterior of the building at a minimum height of eight (8) feet above grade directly in line with the exhaust vent terminal for the horizontally vented gas fueled heating appliance or equipment. The sign shall read, in print size no less than one-half (1/2) inch in size, "GAS VENT DIRECTLY BELOW. KEEP CLEAR OF ALL OBSTRUCTIONS".

4. **INSPECTION.** The state or local gas inspector of the side wall horizontally vented gas fueled equipment shall not approve the installation unless, upon inspection, the inspector observes carbon monoxide detectors and signage installed in accordance with the provisions of 248 CMR 5.08(2)(a)1 through 4.

(b) **EXEMPTIONS:** The following equipment is exempt from 248 CMR 5.08(2)(a)1 through 4:

1. The equipment listed in Chapter 10 entitled "Equipment Not Required To Be Vented" in the most current edition of NFPA 54 as adopted by the Board; and

2. Product Approved side wall horizontally vented gas fueled equipment installed in a room or structure separate from the dwelling, building or structure used in whole or in part for residential purposes.

(c) **MANUFACTURER REQUIREMENTS - GAS EQUIPMENT VENTING SYSTEM PROVIDED.** When the manufacturer of Product Approved side wall horizontally vented gas equipment provides a venting system design or venting system components with the equipment, the instructions provided by the manufacturer for installation of the equipment and the venting system shall include:

1. Detailed instructions for the installation of the venting system design or the venting system components; and

2. A complete parts list for the venting system design or venting system.

(d) **MANUFACTURER REQUIREMENTS - GAS EQUIPMENT VENTING SYSTEM NOT PROVIDED.** When the manufacturer of a Product Approved side wall horizontally vented gas fueled equipment does not provide the parts for venting the flue gases, but identifies "special venting systems", the following requirements shall be satisfied by the manufacturer:

1. The referenced "special venting system" instructions shall be included with the appliance or equipment installation instructions; and

2. The "special venting systems" shall be Product Approved by the Board, and the instructions for that system shall include a parts list and detailed installation instructions.

(e) A copy of all installation instructions for all Product Approved side wall horizontally vented gas fueled equipment, all venting instructions, all parts lists for venting instructions, and/or all venting design instructions shall remain with the appliance or equipment at the completion of the installation.

GAS PRESSURE SUPERVISION

The Commonwealth of Massachusetts requires listed high and low gas pressure switches (manual reset) for any model with a maximum firing input greater than 1,000,000 Btu/Hr in accordance with 248 CMR 7.04(11)(d).

A gas pressure regulator (field supplied) is required in the gas train ahead of the heater, for heaters having input rates greater than 1,000,000 Btu/Hr, in accordance with 248 CMR 7.04 Figure 3B requirements.



**LIMITED PARTS WARRANTY
XFYRE – TYPE H and WH
MODELS 300-850**

SCOPE

Raypak, Inc. ("Raypak") warrants to the original owner that all parts of this heater which are actually manufactured by Raypak will be free from failure under normal use and service for the specified warranty periods and subject to the conditions set forth in this Warranty. Labor charges and other costs for parts removal or reinstallation, shipping and transportation are not covered by this Warranty but are the owner's responsibility.

HEAT EXCHANGER WARRANTY

Space Heating (Closed Loop System)

Ten (10) year limited warranty from date of heater installation. This warranty applies only to boilers utilized in closed loop heating systems and hot water supply boilers that have been properly installed based upon manufacturer's installation instructions.

<u>Year of Claim</u>	<u>0-5</u>	<u>6</u>	<u>7</u>	<u>8</u>	<u>9</u>
Percentage to be paid by purchaser	0 %	20%	40%	60%	80%

Thermal Shock Warranty

Twenty (20) years from date of heater installation against "Thermal Shock" (excluded, however, if caused by heater operation at large changes exceeding 150°F between the water temperature at intake and heater temperature, or operating at heater temperatures exceeding 215°F).

ANY OTHER PART MANUFACTURED BY RAYPAK

One (1) year warranty from date of heater installation, or eighteen (18) months from date of factory shipment based on Raypak's records, whichever comes first.

SATISFACTORY PROOF OF INSTALLATION DATE, SUCH AS INSTALLER INVOICE, IS REQUIRED. THIS WARRANTY WILL BE VOID IF THE HEATER RATING PLATE IS ALTERED OR REMOVED.

ADDITIONAL WARRANTY EXCLUSIONS

- This warranty does not cover failures or malfunctions resulting from:
1. Failure to properly install, operate or maintain the heater in accordance with our printed instructions provided;
 2. Abuse, alteration, accident, fire, flood and the like;
 3. Sediment or lime build-up, freezing, or other conditions causing inadequate water circulation;
 4. High velocity flow exceeding heater design rates;
 5. Failure of connected system devices, such as pump or controller;
 6. Use of non-factory authorized accessories or other components in conjunction with the heater system;
 7. Failing to eliminate air from, or replenish water in, the connected water system;
 8. Chemical contamination of combustion air or use of chemical additives to water.

PARTS REPLACEMENT

Under this Warranty, Raypak will furnish a replacement for any failed part. The failed part must first be returned to Raypak if requested, with transportation charges prepaid, and all applicable warranty conditions found satisfied. The replacement part will be warranted for only the unexpired portion of the original warranty. Raypak makes no warranty whatsoever on parts not manufactured by it, but Raypak will apply any such warranty as may be provided to it by the parts manufacturer.

TO MAKE WARRANTY CLAIM

Promptly notify the original installer, supplying the model and serial numbers of the unit, date of installation and description of the problem. The installer must then notify his Raypak distributor for instructions regarding the claim. If either is not available, contact Service Manager, Raypak, Inc., 2151 Eastman Avenue, Oxnard, CA 93030 or call (805) 278-5300. In all cases proper authorization must first be received from Raypak before replacement of any part.

EXCLUSIVE WARRANTY - LIMITATION OF LIABILITY

This is the only warranty given by Raypak. No one is authorized to make any other warranties on Raypak's behalf. THIS WARRANTY IS IN LIEU OF ALL OTHER WARRANTIES, EXPRESS OR IMPLIED, INCLUDING BUT NOT LIMITED TO IMPLIED WARRANTIES OF MERCHANTABILITY AND FITNESS FOR A PARTICULAR PURPOSE. RAYPAK'S SOLE LIABILITY AND THE SOLE REMEDY AGAINST RAYPAK WITH RESPECT TO DEFECTIVE PARTS SHALL BE AS PROVIDED IN THIS WARRANTY. IT IS AGREED THAT RAYPAK SHALL HAVE NO LIABILITY, WHETHER UNDER THIS WARRANTY, OR IN CONTRACT, TORT, NEGLIGENCE OR OTHERWISE, FOR ANY SPECIAL, CONSEQUENTIAL, OR INCIDENTAL DAMAGE, INCLUDING DAMAGE FROM WATER LEAKAGE. Some states do not allow limitations on how long an implied warranty lasts, or for the exclusion of incidental or consequential damages. So the above limitation or exclusion may not apply to you.

This Limited Warranty gives you specific legal rights. You may also have other rights which may vary from state to state. We suggest that you complete the information below and retain this certificate in the event warranty service is needed. Reasonable proof of the effective date of the warranty (date of installation) must be presented; otherwise, the effective date will be based on the date of manufacture plus thirty (30) days.

_____	_____
Original Owner	Model Number
_____	_____
	Serial Number
_____	_____
Mailing Address	Date of Installation
_____	_____
City State Zip Code	Installation Site
_____	_____
Daytime Telephone Number	Contractor/Installer

RAYPAK, INC • 2151 Eastman Avenue • Oxnard, CA 93030-9786 • (805) 278-5300 • Fax (800) 872-9725 • www.raypak.com

START-UP CHECKLIST FOR THE XFYRE

This start-up checklist is to be completely filled out by the service technician starting up the Raypak Boiler or Heater for the first time. All information may be used for warranty purposes and to ensure that the installation is correct. Additionally this form will be used to record all equipment operation functions and required settings.

GAS SUPPLY DATA

Regulator Model & Size _____ / _____ CFH
 Gas Line Size (in room) _____ In. NPT
 Length of Gas Line _____ Eq Ft
 Low Gas Pressure Setting _____ In. WC
 High Gas Pressure Setting _____ In. WC
 Gas Shut-Off Valve Type _____
 (Ball, Lube cock)
 Sediment Trap _____ Y/N
 Port _____ Std _____ Full

CLEARANCES

Front Clearance _____ In.
 Right Side Clearance _____ In.
 Left Side Clearance _____ In.
 Rear Clearance _____ In.
 Overhead Clearance _____ In.

ELECTRICAL

Voltage Supply (VAC) _____ No Load _____ Load _____
 Voltage -24 VAC _____ VAC
 Voltage Com to Ground _____ VAC
 Auto High Limit Setting _____ deg F
 Manual Reset High Limit Setting _____ deg F
 Operating Control Setting _____ deg F

VISUAL INSPECTION OF COMPONENTS

Verify inspection was done and condition of components are in good working order with a "yes"

Wiring Harness _____ Y/N
 Burner/s (flame) _____ Y/N
 Refractory (visual) _____ Y/N
 Remote flame sense _____ Y/N
 Covers in place for outdoor _____ Y/N

Sketch plumbing on reverse side

WATER SUPPLY

Flow Rate in GPM or Delta T _____ If Avail
Measure flow rate at full fire
 Pump Off Delay setting _____ Minutes
 Low Water Cutoff _____ Test
 Number of Tanks and Size _____ Qty _____ Gallons
 Plumbing Size _____
 Pump Size: _____ (boiler) _____ Pump HP: _____
 Impeller trim _____ Pump Model _____
 Louvers _____ Screens _____

VENTING

Vent Size: _____ Stack Height: _____
 Category: _____ sketch vent on reverse side ***
 Vent Material: _____
 Vent Termination Type: _____
 Combustion Air Openings: Low _____ in2
 Ventilation air High _____ in2

Nominal Factory Recommended Settings

EMISSIONS SETTINGS AND TEST INFORMATION

	High	Low	
Air Intake Pressure		N/A	In. WC
Supply Gas Pressure			In. WC
Verify stable pressure static & dynamic condition			
Manifold Gas Pressure			In. WC

See manual or card tag
 See manual or card tag
 See manual or card tag

The following measurements must be obtained with a Combustion Analyzer.

NOX	_____	PPM	Less than 20 PPM (If required by Certifying Agency)
CO	_____	PPM	Less than 150 PPM
CO2	_____	%	See manual

Model Number: _____
 *** Note: draw venting with details, such as extractors, barometric dampers, blast dampers or draft inducers

Serial Number: _____
 Site Altitude Above Sea Level _____ Ft.

Job Name _____

Address _____

Physical Location of Boiler: Indoors _____; Outdoors _____; Ground Level _____; Roof _____; Below Grade _____

Mechanical Contractor / Installer _____

Date and Time of Start-up _____ Print Name and Signature of Start-up Technician _____

Information must be faxed to: (805) 278-5471 in order to ensure warranty consideration Attn: Service Manager



www.raypak.com

Raypak, Inc., 2151 Eastman Avenue, Oxnard, CA 93030 (805) 278-5300 Fax (805) 278-5468
Litho in U.S.A.