

INSTALLATION AND OPERATION MANUAL

VERSTML

Models 406L - 856L Type H



⚠ WARNING: Improper installation, adjustment, alteration, service, or maintenance can cause property damage, personal injury, exposure to hazardous materials*, or loss of life. Review the information in this manual carefully. *This unit contains materials that have been identified as carcinogenic, or possibly carcinogenic, to humans.

FOR YOUR SAFETY: Do not store or use gasoline or other flammable vapors and liquids or other combustible materials in the vicinity of this or any other appliance. To do so may result in an explosion or fire.

WHAT TO DO IF YOU SMELL GAS:

- Do not try to light any appliance.
- Do not touch any electrical switch; do not use any phone in your building.
- Immediately call your gas supplier from a neighbor's phone. Follow the gas supplier's instructions.
- If you cannot reach your gas supplier, call the fire department.

Installation and service must be performed by a qualified installer, service agency or the gas supplier.

This manual should be maintained in legible condition and kept adjacent to the boiler or in a safe place for future reference.

Raypak[®]
A Rheem[®] Company

Effective: 04-09-2021
Replaces: 01-15-2021
P/N 241782 Rev. 5

QUICK START GUIDE

CLEARANCES

- Space required: 3 ft. x 3 ft (0.9 m x 0.9 m). See page **8**.
- Minimum and service clearances: See page **10** for clearances table. Note that local code prevails.

COMBUSTION AIR

- Air filter location: See page **12**.
- Ducting materials: PVC, CPVC, or sealed single-wall galvanized ducting, see page **12** for details.

PIPING

- Piping options: Primary/secondary piping. Note that the heater should be located so that any water leaks will not cause damage to the adjacent area.
- Pressure relief valve: See page **14** for recommended PRV orientation.
- Flow rates: See page **15** for flow values table.
- Primary/secondary piping: See pages **16-23** for recommended configurations (including single heater and cascades).
- Tanks: All heaters should be equipped with a properly-sized expansion tank and air separator fitted at the highest point in the system.

GAS

- Distance to regulator (pipe lengths) and gas inlet sizes: See page **24**.
- Required pressure for natural gas:
Min. = 4" WC, Max. = 10.5" WC
- Required pressure for propane:
Min. = 4" WC, Max. = 13" WC
- Sediment trap is required for all installations.

POWER

- Supply voltage: See page **25** for input voltage table.

VENTING - CAT IV

- Materials: PVC, CPVC, Polypropylene, stainless steel, see pages **32-33**.
- Venting diagrams:
For stainless steel and polypro, see pages **34-37**.
For PVC/CPVC see pages **38-40**.
- Outdoor venting:
Outdoor Vent Kit. See page **41**.

CONTROLS INTERFACE

- User interface:
VIEW menu is the default menu, see page **50**.
To change settings, use the SETUP/ADJUST menu, see page **52**.
- Wiring diagram: See page **57**.

OPERATION

- Boiler Status Light: See page **63**.

Revision 5 reflects the following changes:

IPL: 8-B Added "IGNITER DSI XVERS L" to title; 3-C kit number changed to "013175F" for all sizes; 4-C kit number changed to "013932F" for all sizes; Removed "15-C Gasket SS Valve" from the IPL; 1-F added "Includes 2-F" to title; 2-F revised kit to "018972F" for 406L size; 1-M separated callouts for "manufactured prior to" 016796F and "after to" 018768F for all sizes; 2-M added "(not shown)" to title; 4-M (PRV 30 psi) updated kit numbers to 007470F for 406L, 007217F for sizes 506L & 606L and 007218F for size 726L; 4-M (PRV 45 psi) updated kit numbers to 007220F for 406L & 506L, 007346F for sizes 606L & 726L and 007221F for size 856L; 4-M (PRV 60 psi) updated kit numbers 007223F for sizes 606L, 726L & 856L; 1-P added "N/A" for sizes 406L through 726L; 3-P added "N/A" for size 856L; 19-S updated kit number to 017782F for size 606L; 20-S updated kit number to 017785F for size 726L & 856L.

CONTENTS

1. WARNINGS	4	Horizontal Through-the-Wall and Direct Vent - Horizontal - PVC/CPVC.....	39
Pay Attention to These Terms	4	Outdoor Installation.....	41
2. BEFORE INSTALLATION	5	Common Venting	41
Product Receipt	5	Condensate Treatment	42
Model Identification.....	5	Freeze Protection	43
Ratings and Certifications.....	5	5. CONTROLS	43
Installations at Elevation	5	Sequence of Operation.....	43
3. WATER TREATMENT	6	VERSA Integrated Control	45
Water Quality Requirements to Prevent Scaling and Corrosion	6	Glycol % Setting	46
Fill Water Hardness	6	Vent Protection	46
Operating Water Requirement.....	6	Control Devices	47
4. INSTALLATION	6	User Interface	50
Installation Codes	6	6. WIRING DIAGRAM	57
Component Locations.....	7	7. START-UP	58
Equipment Base	8	Pre Start-up	58
Clearances.....	8	Pre Start-up Check	58
Pallet Jack/Forklifting.....	9	Initial Start-up.....	58
Outdoor Installation.....	10	Preparation	58
Combustion and Ventilation Air.....	12	Start-Up	59
Inside Air Contamination.....	12	8. OPERATION	62
Air Supply	13	Lighting Instructions.....	62
Water Piping	14	To Turn Off Gas To Appliance	63
Hydronic Heating	15	Boiler Status Light.....	63
Gas Supply Connection	24	9. TROUBLESHOOTING	63
Electrical Power Connections	25	XVersL Error Codes.....	63
Multiple Voltage Configurations	26	Heater Errors	63
Field-Connected Devices.....	26	Heater Faults	63
Venting - General.....	31	Raymote Troubleshooting.....	64
Vent Terminal Location	31	XVersL Fault Text.....	64
Venting Installation Tips	34	10. MAINTENANCE	66
Venting Configurations.....	34	Suggested Minimum Maintenance Schedule	66
Vertical Venting (Category IV) - Stainless Steel and Polypropylene	34	Preventive Maintenance Schedule	67
Direct Vent-Vertical - Stainless Steel and Polypropylene	35	Filter Maintenance	67
Horizontal Through-the-Wall and Direct Vent - Horizontal - Stainless Steel and Polypropylene....	36	11. ILLUSTRATED PARTS LIST	68
Vertical Venting (Category IV) - PVC/CPVC	37	12. IMPORTANT INSTRUCTIONS FOR THE COMMONWEALTH OF MASSACHUSETTS	74
Direct Vent - Vertical - PVC/CPVC.....	38		

NOTE: Patent-pending features utilized in XVersL construction and operation.

1. WARNINGS

Pay Attention to These Terms

▲ DANGER	Indicates the presence of immediate hazards which will cause severe personal injury, death or substantial property damage if ignored.
▲ WARNING	Indicates the presence of hazards or unsafe practices which could cause severe personal injury, death or substantial property damage if ignored.
▲ CAUTION	Indicates the presence of hazards or unsafe practices which could cause minor personal injury or product or property damage if ignored.
CAUTION	CAUTION used without the warning alert symbol indicates a potentially hazardous condition which could cause minor personal injury or product or property damage if ignored.
NOTE	Indicates special instructions on installation, operation, or maintenance which are important but not related to personal injury hazards.

▲ DANGER: Make sure the gas on which the boiler will operate is the same type as that specified on the boiler rating plate.

▲ WARNING: Risk of electrical shock. More than one disconnect switch may be required to de-energize the equipment before servicing.

▲ WARNING: A boiler model adjusted for natural gas will not function safely on propane and vice-versa, even though the parts are the same. A boiler should only use the fuel type in accordance with the listing on the rating plate. Any other fuel usage will result in death or serious personal injury from fire and/or explosion. Gas type conversion should only be made by qualified installers. The conversion is done by changing settings and making adjustments using a conversion rating plate.

NOTE: Minimum pipe size for the boiler inlet/outlet connections is dependent on the equivalent length of piping between the load loop and the boiler loop, the operating conditions and the size of the boiler. See Table I and Table J.

▲ WARNING: Should overheating occur or the gas supply valve fail to shut, do not turn off or disconnect the electrical supply to the boiler. Instead, shut off the gas supply at a location external to the boiler.

▲ WARNING: Both natural gas and propane have an odorant added to aid in detecting a gas leak. Some people may not physically be able to smell or recognize this odorant. If you are unsure or unfamiliar with the smell of natural gas or propane, ask your local gas supplier. Other conditions, such as “odorant fade,” which causes the odorant to diminish in intensity, can also hide, camouflage, or otherwise make detecting a gas leak by smell more difficult.

▲ WARNING: Do not use this boiler if any part has been under water. Immediately call a qualified service technician to inspect the boiler and to replace any part of the control system and any gas control which has been under water.

▲ CAUTION: If this boiler is to be installed in a negative- or positive-pressure equipment room, there are special installation requirements. Consult factory for details.

▲ WARNING: To minimize the possibility of improper operation, serious personal injury, fire, or damage to the boiler:

- Always keep the area around the boiler free of combustible materials, gasoline, and other flammable liquids and vapors.
- Boiler should never be covered or have any blockage to the flow of fresh air to the boiler.

▲ CAUTION: This boiler requires forced water circulation when the burner is operating. See Table G for flow rate information. Severe damage will occur if the boiler is operated without proper water flow circulation.

2. BEFORE INSTALLATION

Raypak strongly recommends that this manual be reviewed thoroughly before installing your XVersL boiler. Please review the General Safety information before installing the boiler. Factory warranty does not apply to boilers that have been improperly installed or operated. Refer to the warranty at the back of this manual.

Installation and service must be performed by a qualified installer, service agency, or gas supplier. If, after reviewing this manual, you still have questions which this manual does not answer, please contact your local Raypak representative or visit our website at www.raypak.com.

NOTE: Raypak recommends laying out and installing the vent system before installing water piping. This will ensure that the venting system and associated components will fit into the attached space for proper operation.

Thank you for purchasing a Raypak product. We hope you will be satisfied with the high quality and durability of our equipment.

Product Receipt

On receipt of your boiler visually check for external damage to the shipping crate. If the crate is damaged, make a note to that effect on the Bill of Lading when signing for the shipment. Next, remove the boiler from the shipping packaging. Report any damage to the carrier immediately. On occasion, items are shipped loose. Be sure that you receive the correct number of packages as indicated on the Bill of Lading.

Claims for shortages and damages must be filed with the carrier by consignee. Permission to return goods must be received from the factory prior to shipping. Goods returned to the factory without an authorized Returned Goods Receipt number will not be accepted. All returned goods are subject to a restocking charge. When ordering parts, you must specify the model and serial number of the boiler. When ordering under warranty conditions, you must also specify the date of installation.

Purchased parts are subject to replacement only under the manufacturer's warranty. Debits for defective replacement parts will not be accepted. Parts will be replaced in kind only per Raypak's standard warranties.

Model Identification

The model identification number and boiler serial number are found on the rating plate located on the rear jacket panel of the boiler. The model number will have the form H7-856L* or similar depending on the boiler size and configuration.

- The letter(s) in the first group of characters identifies the application (H = Hydronic Heating).
- The number which follows identifies the firing mode (7 = electronic modulation).
- The second group of characters identifies the size of the boiler (the four numbers representing the approximate MBTUH input), and, where applicable, a letter, indicating the manufacturing series.

Ratings and Certifications

Standards

- ANSI Z21.13 · CSA 4.9 - latest edition, Gas-Fired Hot Water Boilers
- CAN 3.1 - latest edition, Industrial and Commercial Gas-Fired Package Boilers

All Raypak boilers are National Board registered, and design-certified and tested by the Canadian Standards Association (CSA) for the U.S. and Canada. Each boiler is constructed in accordance with Section IV of the American Society of Mechanical Engineers (ASME) Heater Pressure Vessel Code and bears the ASME "H" stamp. This boiler also complies with the latest edition of the ASHRAE 90.1 Standard.

⚠ WARNING: Altering any Raypak pressure vessel by installing replacement heat exchangers, or any ASME parts not manufactured and/or approved by Raypak will instantly void the ASME and CSA ratings of the vessel and any Raypak warranty on the vessel. Altering the ASME or CSA ratings of the vessel also violates national, state, and local approval codes.

Installations at Elevation

Rated inputs are suitable for up to 4,500 ft (1,372 m) elevation. Consult your local representative or the factory for installations at altitudes over 4,500 ft (1,372 m) above sea level. No hardware changes are required to the boilers for installations up to 10,000 ft (3,050 m) (adjustments may be required).

3. WATER TREATMENT

Water Quality Requirements to Prevent Scaling and Corrosion

To prevent the formation of scale and sludge in a closed heating circuit through the penetration of oxygen and carbonates, follow the recommendations below:

- Before filling the system, clean it according to standard EN14336. Chemical cleaning agents can be used.
- If the circuit is in bad condition, or the cleaning operation is not efficient, or there is a large volume of water in the system (e.g. cascade), it is recommended to separate the appliance from the heating circuit using a plate-to-plate heat exchanger or an equivalent accessory. In that case, it is recommended to install a hydro-cyclone or magnetic filter on the system side.
- Limit the fill operations. To control the quantity of water added into the system, install a water meter on the filling line of the primary circuit. No more than 5% of the total content of the system is allowed annually.
- Automatic filling systems are not recommended unless the fill frequency is checked and the levels of scale and corrosion inhibitor are maintained at an appropriate level. If the system needs to be refilled frequently, check for leaks in the primary circuit.
- Inhibitors may be used according to standard EN 14868.
- An air separator (on the appliance supply circuit) combined with a dirt separator (upstream of the appliance) must be installed according to the manufacturer's instructions.
- Additives can be used to keep the oxygen in solution in the water.
- Use the additives in accordance with the instructions of the manufacturer of the water treatment product.

Fill Water Hardness

If the hardness of the fill water is higher than 200 PPM, soften it. At commissioning, the water should be soft.

Check the water hardness regularly and enter the values in the maintenance log sheet (provided at the end of the manual).

Water Hardness	PPM
Very soft	0-70
Soft	70-150
Fairly Hard	150-250
Hard	250-420
Very Hard	>420

Table A. Water Hardness

Operating Water Requirement

- In addition to the oxygen and the water hardness, other parameters of the water must be checked. Treat the water if the measured values are outside the range of the table below.
- In case the system operates at low temperature, it may be necessary to use an agent that inhibits the spread of bacteria.

Water Parameters	Range
Acidity	8.2 < pH < 9.0
Conductivity	< 400 uS/cm (at 25°C)
Chlorides	< 150 mg/l
Iron	< 0.5 mg/l
Copper	< 0.1 mg/l
TDS	< 2000 PPM

Table B. Water Hardness

4. INSTALLATION

Installation Codes

Installations must follow these codes:

- Local, state, provincial, and national codes, laws, regulations and ordinances
- National Fuel Gas Code, ANSI Z223.1/NFPA 54 – latest edition (NFGC)
- National Electrical Code, ANSI/NFPA 70 - latest edition (NEC)
- Standard for Controls and Safety Devices for Automatically Fired Boilers, ANSI/ASME CSD-1, (CSD-1) when required
- For Canada only: CAN/CSA B149 Natural Gas and Propane Installation Code and CSA C22.1 C.E.C. Part 1 (C22.1)

Model No.	Input MBTUH (Kw)		Flue Size in. (mm)	
	Max	Min	Flue	Intake
406L	399 (117)	40 (11.72)	4 (100)	4 (100)
506L	500 (147)	50 (14.65)	4 (100)	4 (100)
606L	600 (176)	85.7 (25.12)	4 (100)	4 (100)
726L	725 (213)	103.6 (30.36)	6 (150)	6 (150)
856L	850 (250)	121.4 (35.58)	6 (150)	6 (150)

Table C. Basic Product Data

Component Locations

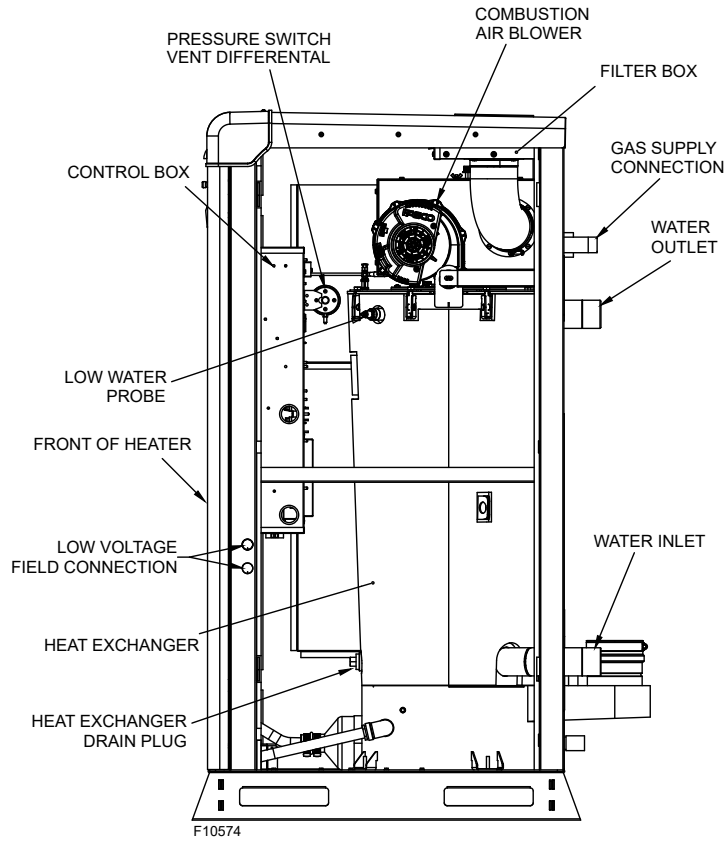

Figure 1. Component Locations – Side View

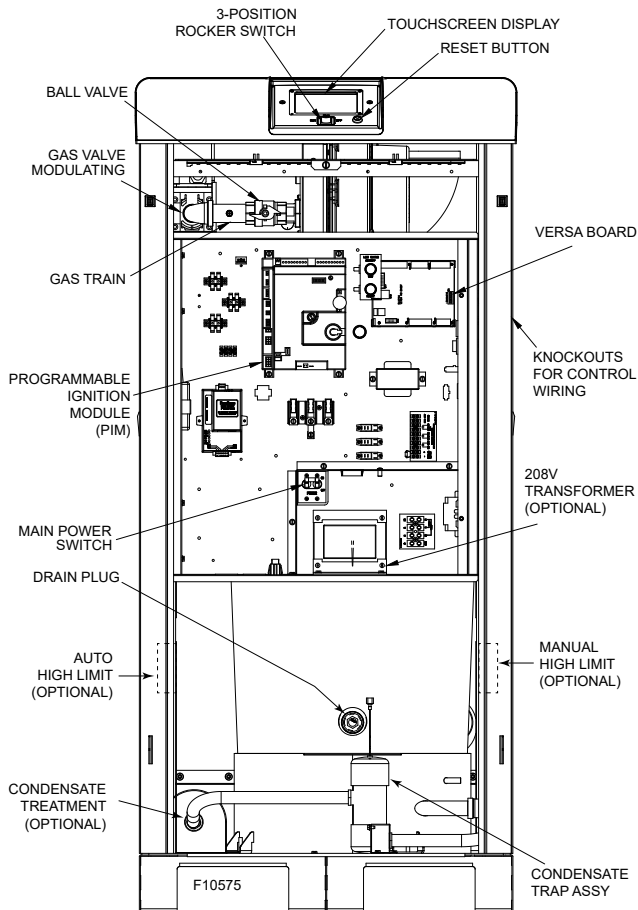

Figure 2. Component Locations - Front View

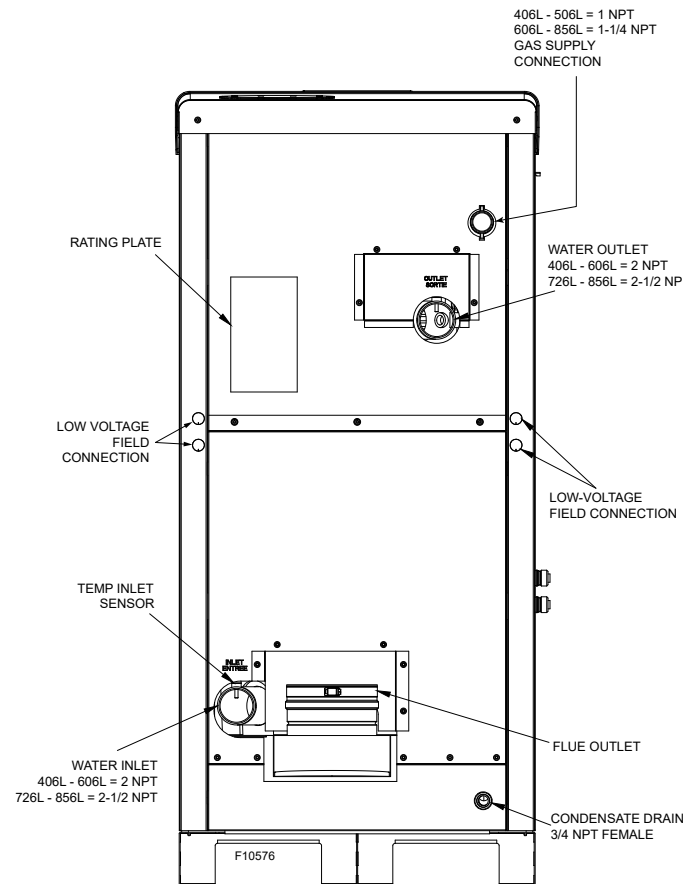

Figure 3. Component Locations - Rear View

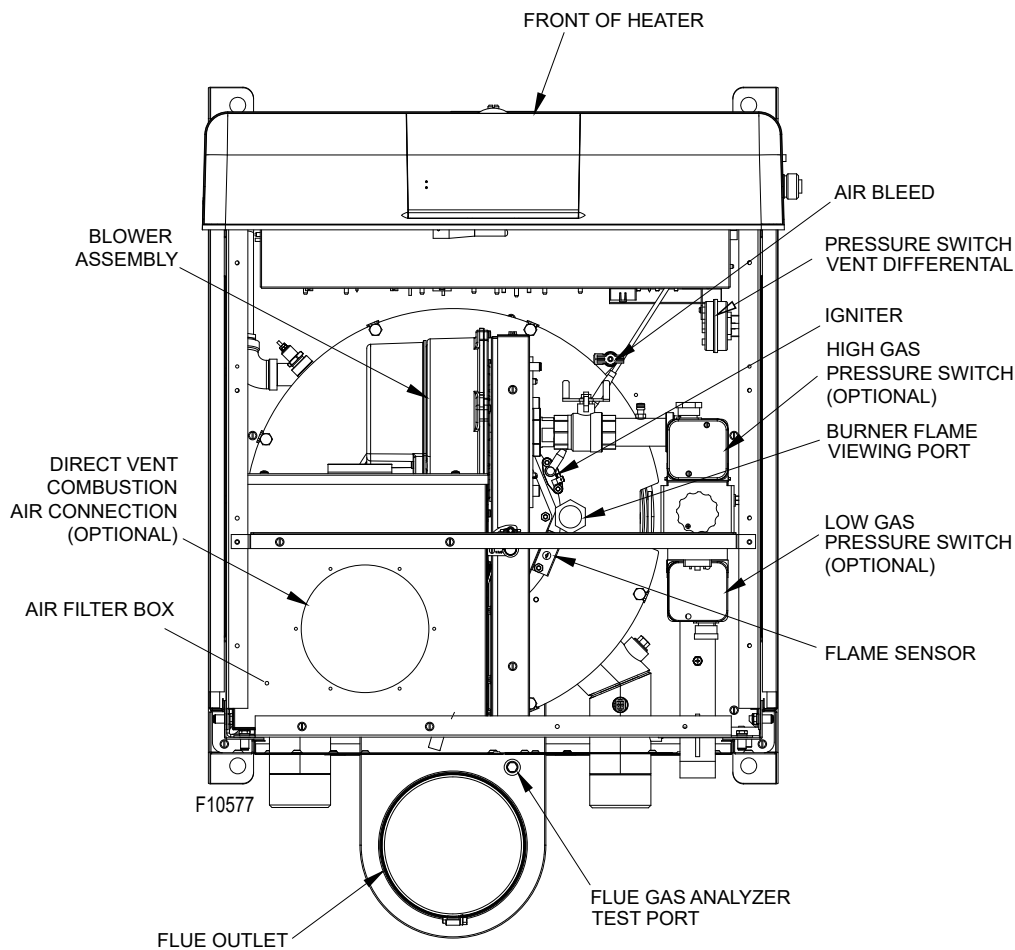

Figure 4. Component Locations - Top View

Equipment Base

The boiler should be mounted on a level, structurally sound surface. The boiler is approved for installation on a combustible surface but must NEVER be installed on carpeting. Gas-fueled equipment installed in enclosed parking garages must be located at least 18" (457 mm) above the floor.

CAUTION: This boiler should be located in an area where water leakage will not result in damage to the area adjacent to the appliances or to the structure.

In addition, the boiler shall be installed such that the gas ignition system components are protected from water (dripping, spraying, rain, etc.) during appliance operation or service (circulator replacement, control replacement, etc.).

If the boiler needs to be secured to the ground, use the hole pattern shown in **Figure 7** and **Figure 8**, following local codes.

Clearances

Indoor Installations

Heater Side	Minimum Clearances from Combustible Surfaces in. (mm)	Minimum Service Clearance in. (mm)
Floor *	0	0
Rear	24 (610)	24 (610)
Right Side	0	0
Left Side	0	0
Top	0	24 (610)
Front	Open	30 (762)
Vent	1 (25)	1 (25)

* DO NOT install on carpeting

Table D. Clearances - Indoor Installations

For ease of servicing, a clearance of at least 30" (762 mm) in front, at least 24" (610 mm) on the rear and 24" (610 mm) above the top of the boiler is required. This will allow the boiler to be serviced in its installed location without movement or removal of the boiler.

Service clearances less than the minimum may require removal of the boiler to service either the heat exchanger or the burner components. In either case, the boiler must be installed in a manner that will enable the boiler to be serviced without removing any structure around the boiler.

Pallet Jack/Forklifting

The XVersL boilers are designed to be moved by pallet jack or forklift (front side or either side). See **Figure 5** and **Figure 6**.

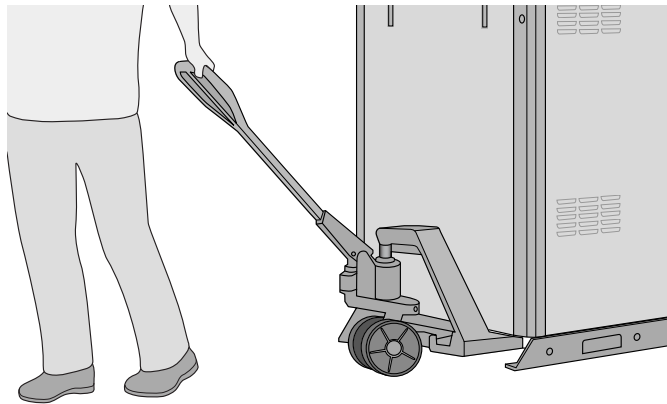

Figure 5. Pallet Jack

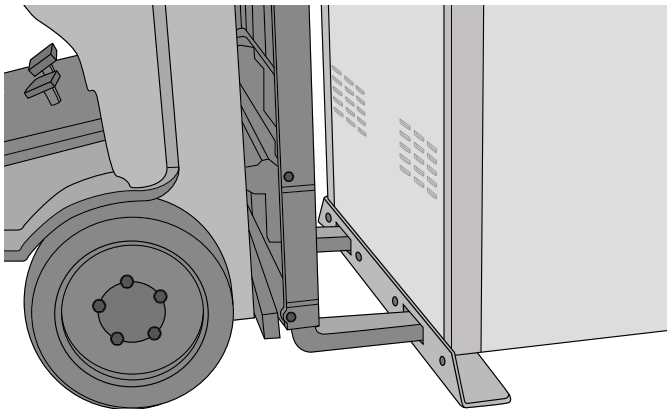

Figure 6. Forklifting

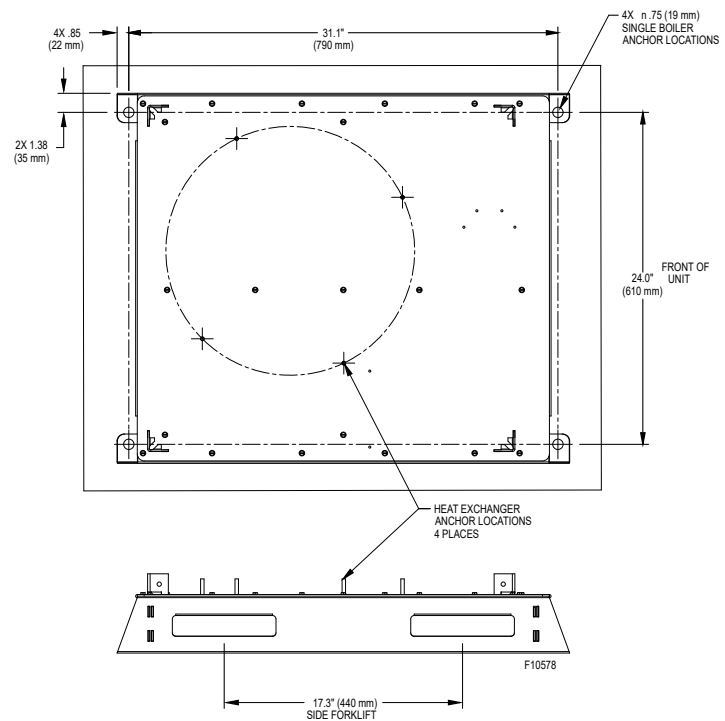

Figure 7. Single Unit Anchor Hole Locations

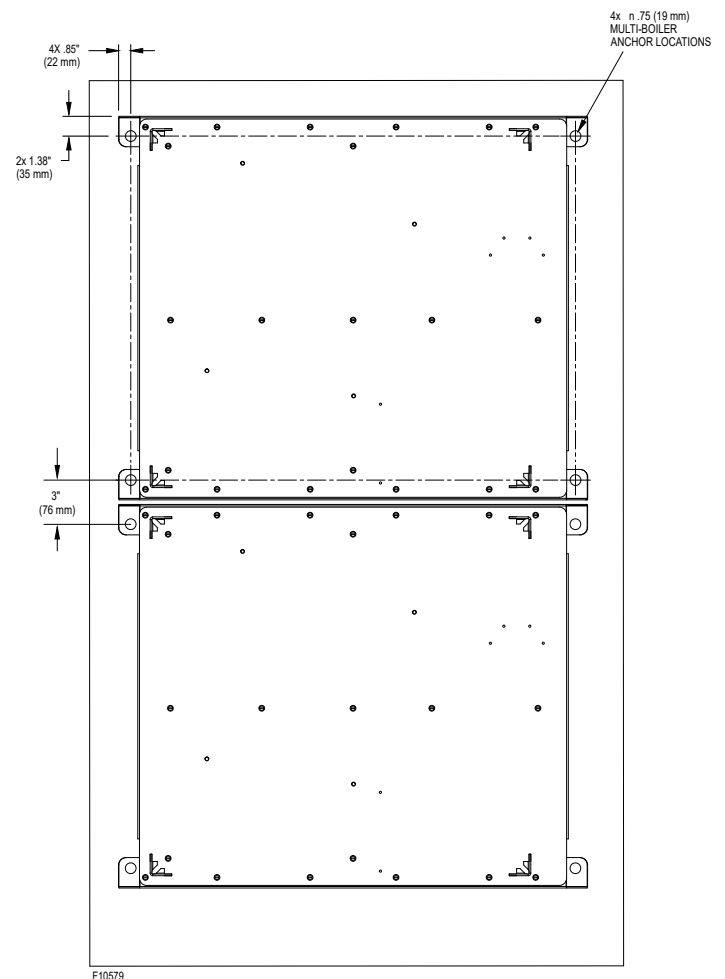

Figure 8. Multiple Unit Anchor Hole Locations

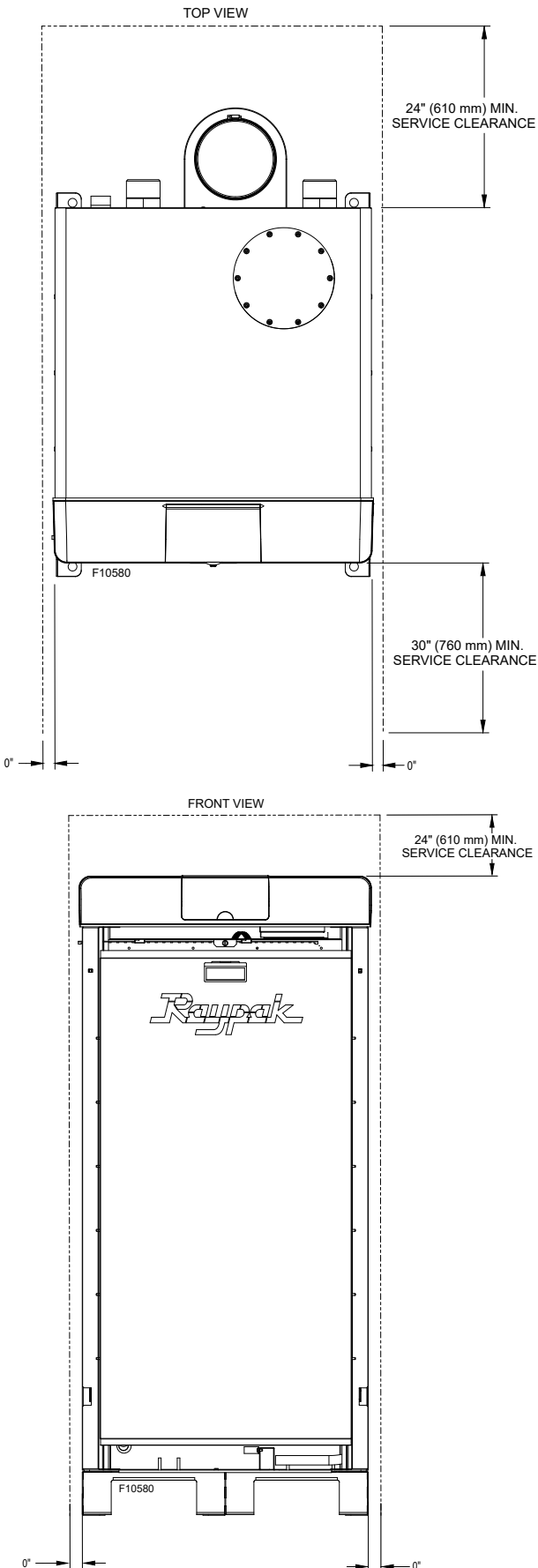

Figure 9. Minimum Clearances from Combustible Surfaces – Indoor and Outdoor Installations

Outdoor Installation

CAUTION: DO NOT install XVersL boilers outdoors in freezing climates.

NOTE: Housekeeping pad of adequate height required for outdoor units to protect boiler from standing water and to allow for proper management of condensate.

These units may be installed outdoors when provided with the factory-supplied and required outdoor trim.

Boilers must not be installed under an overhang unless clearances are in accordance with local installation codes and the requirements of the gas supplier.

Three sides must be open in the area under the overhang. Roof water drainage must be diverted away from boilers installed under overhangs.

Combustion air is drawn through the louvers in the jacket. DO NOT remove the cap as shipped from the factory.

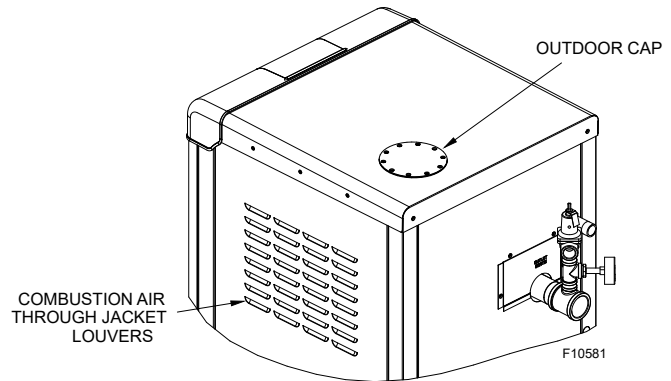

Figure 10. Outdoor Combustion Air

CAUTION: Do not install where the condensate can freeze. Take appropriate measures.

Heater Side	Minimum Clearances from Combustible Surfaces in. (mm)	Minimum Service Clearance in. (mm)
Rear	12 (305)	24 (610)
Front	Open	30 (762)
Left Side	1 (25)	1 (25)
Right Side	1 (25)	1 (25)
Top	Unobstructed	Unobstructed
Vent Termination	Open	Open

Table E. Clearances – Outdoor Installations

NOTE: Vent termination must not terminate less than 3 ft (0.9 m) below eaves, soffits, or overhangs.

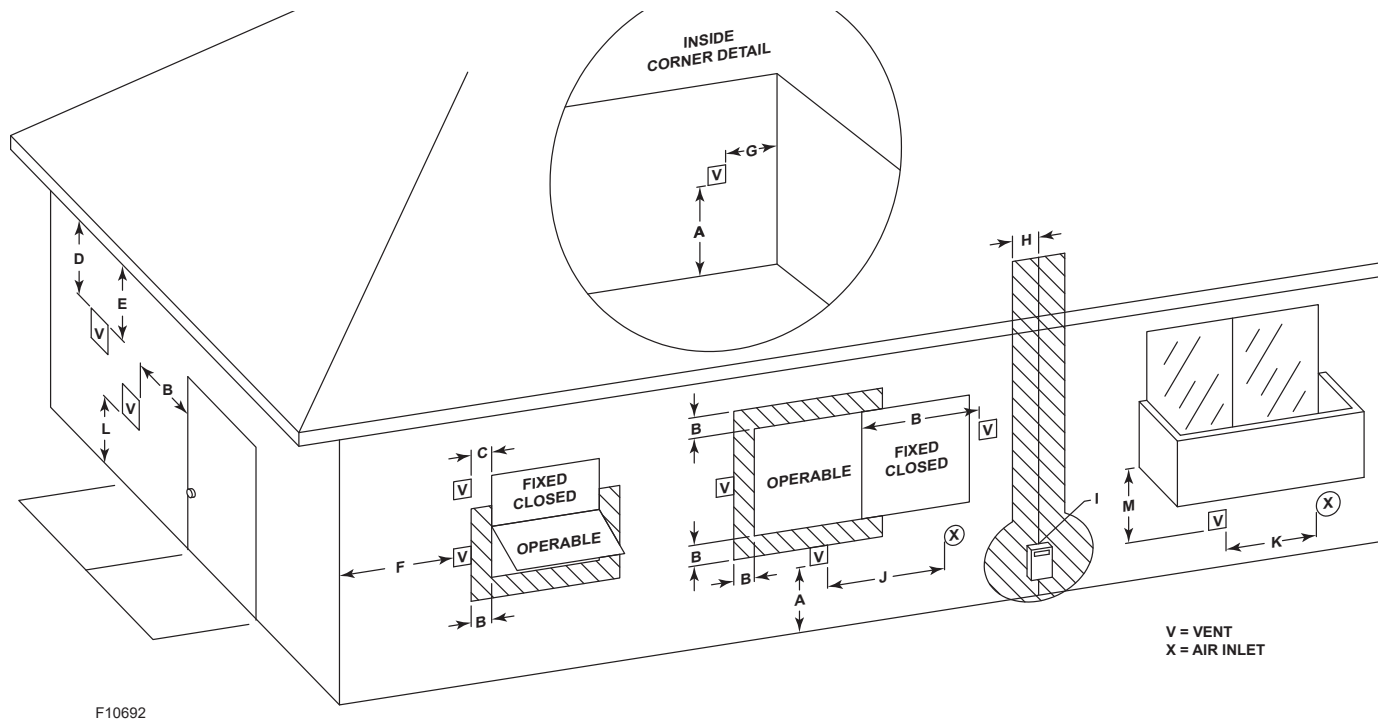

F10692

Figure 11. Minimum Clearances from Vent/Air Inlet Terminations – Indoor and Outdoor Installations

		U.S. Installations ¹	Canadian Installations ²
A	Clearance above grade, veranda, porch, deck, or balcony	1' (30 cm)	1' (30 cm)
B	Clearance to window or door that may be opened	4' (1.2 m) below or to side of opening	3' (91 cm)
C	Clearance to permanently closed window	*	*
D	Vertical clearance to ventilated soffit located above the terminal within a horizontal distance of 2' (61 cm) from the centerline of the terminal	5' (1.5 m)	*
E	Clearance to unventilated soffit	*	*
F	Clearance to outside corner	*	*
G	Clearance to inside corner	6' (1.83 m)	*
H	Clearance to each side of center line extended above meter/regulator assembly	*	3' (91 cm) within a height 15' above the meter/regulator assembly
I	Clearance to service regulator vent outlet	*	6' (1.83 m)
J	Clearance to non-mechanical air supply inlet to building or the combustion air inlet to any other appliance	4' (1.2 m) below or to side of opening; 1' (30 cm) above opening	3' (91 cm)
K	Clearance to mechanical air supply inlet	3' (91 cm) above if within 10' (3 m) horizontally	6' (1.83 m)
L	Do not terminate above paved sidewalk or paved driveway	Slip hazard due to frozen condensate	Slip hazard due to frozen condensate
M	Clearance under veranda, porch, deck or balcony	*	12" (30 cm) ³

¹ In accordance with the current ANSI Z223.1/NFPA 54 National Fuel Gas Code.

² In accordance with the current CAN/CSA-B149 Installation Codes.

³ Permitted only if veranda, porch, deck, or balcony is fully open on a minimum of two sides beneath the floor and top of terminal, and underside of veranda, porch, deck or balcony is greater than 1' (30 cm).

* Clearances in accordance with local installation codes and the requirements of the gas supplier.

Table F. Vent/Air Inlet Termination Clearances

Combustion and Ventilation Air

NOTE: Use of this boiler in construction areas where fine particulate matter, such as concrete or dry-wall dust, is present may result in damage to the boiler that is not covered by the warranty. If operated in a construction environment, a clean source of combustion air must be provided directly to the boiler.

Inside Air Contamination

All boilers experience some condensation during start-up. The XVersL product line is designed to handle this safely. The condensate from flue gas is acidic. Combustion air can be contaminated by certain vapors in the air which raise the acidity of the condensate. Higher acidity levels attack many materials including stainless steel, which is commonly used in high efficiency systems. The boiler can be supplied with corrosion-resistant, non-metallic intake air vent material. You may, however, choose to use outside combustion air for one or more of these reasons:

1. Installation is in an area containing contaminants listed below which will induce acidic condensation.
2. You want to reduce infiltration into your building through openings around windows and doors.
3. You are using AL29-4C stainless steel, PVC, CPVC or Polypropylene vent pipe, which is more corrosion-resistant than standard metallic vent pipe. In extremely contaminated areas, this may also experience deterioration.

Products causing contaminated combustion air:

- spray cans containing chloro/fluorocarbons
- permanent wave solutions
- chlorinated waxes/cleaners
- chlorine-based swimming pool chemicals
- calcium chloride used for thawing
- sodium chloride used for water softening
- refrigerant leaks
- paint or varnish removers
- hydrochloric acid/muriatic acid
- cements and glues
- antistatic fabric softeners used in clothes dryers
- chloride-type bleaches, detergents, and cleaning solvents found in household laundry rooms
- adhesives used to fasten building products
- similar products

Areas where contaminated combustion air commonly exists:

- dry cleaning/laundry areas
- metal fabrication plants
- beauty shops

- refrigeration repair shops
- photo processing plants
- auto body shops
- plastic manufacturing plants
- furniture refinishing areas and establishments
- new building construction
- remodeling areas
- open pit skimmers

Check for areas and products listed above before installing boiler. If found:

- remove products permanently, OR
- install direct Vent/Truseal option

Indoor Units

This boiler must be supplied with sufficient quantities of non-contaminated air to support proper combustion and equipment ventilation. Combustion air can be supplied via conventional means where combustion air is drawn from the area immediately surrounding the boiler, (as shipped from factory, combustion air is drawn through louvers in jacket panels) or via direct vent, where combustion air is drawn directly from outside. All installations must comply with the requirements of the NFGC (U.S.) and B149 (Canada), and all local codes.

CAUTION: Combustion air must not be contaminated by corrosive chemical fumes which can damage the boiler and cause a non-warrantable failure.

NOTE: It is recommended that the intake vent be insulated to minimize sweating in freezing climates.

Air Filter

An air filter is supplied standard with the boiler. Models 406L-606L use a 10" x 10" MERV 8 filter while models 726L-856L use a 12" x 12" MERV 8 filter. Remove top panel and filter access panel to inspect and/or replace the air filter. See **Figure 12**.

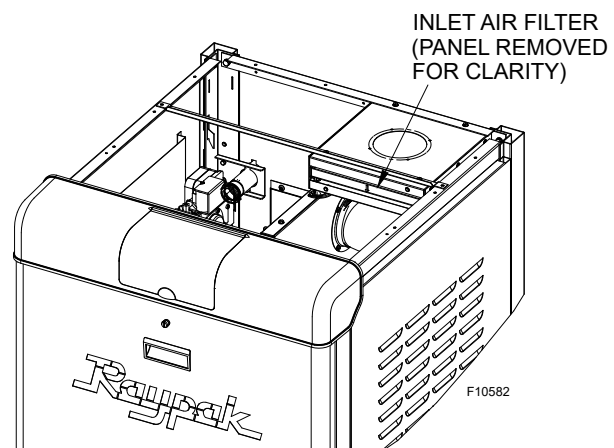

Figure 12. Air Filter Location

Direct Vent/Truseal[®] Option

Combustion air may be ducted directly to the boiler using PVC, CPVC, or sealed single-wall galvanized ducting. The resulting installation meets the requirements for a direct-vent installation. See venting section for detailed information.

1. Install combustion air duct to the Air Intake Connection. See **Figure 4** and **Figure 10**. Remove and discard the outdoor cap, retaining the gasket. Install the intake air adapter (option 9-V in the Illustrated Parts List). Connect ducting material to the adapter collar. Seal the joint and fasteners with RTV (not supplied). All ducting shall be self-supporting.
2. In cold climates, and to mitigate potential freeze-up, Raypak highly recommends the installation of a motorized sealed damper to prevent the circulation of cold air through the boiler during non-operating hours. The optional Motorized Combustion Air Damper (sales option D-37) meets these needs.
3. Ventilation of the room occupied by the boiler(s) is required and can be provided by an opening(s) for ventilation air within 12" (305 mm) of the highest practical point communicating with the outdoors. The total cross-sectional area of these openings shall be at least 1 square inch free air space per 20,000 BTUH (111 mm² per kW) of total input rating of all equipment in the room, when the opening is communicating directly with the outdoors or through vertical duct(s). The total cross-sectional area shall be at least 1 square inch of net free air space per 10,000 BTUH (222 mm² per kW) of total input rating of all equipment in the room, when the opening is communicating with the outdoors through horizontal duct(s). Damage to the equipment due to inadequate ventilation of the space is not a warrantable failure.

Motorized Combustion Air Dampers (D-37) or Louvers

When motorized dampers or louvers are used for combustion air, they must be interlocked with each appliance in the equipment room, to ensure proper operation.

See the installation instructions with the damper kit for proper wiring instructions, using Fan/Damper dry contacts and external interlock.

⚠ WARNING: When unit is installed in the freezing climates using ducted combustion air, a motorized damper must be used and must be interlocked with the boiler per NFGC requirements.

CAUTION: All ducting must be self-supported.

Air Supply

U.S. Installations

All Air from Inside the Building

The confined space shall be provided with TWO permanent openings communicating directly with an additional room(s) of sufficient volume so that the combined volume of all spaces meets the criteria for a room large in comparison (NFGC). The total input of all gas utilization equipment installed in the combined space shall be considered in making this determination. Each opening shall have a minimum free area of 1 square inch per 1,000 BTUH (2,225 mm² per kW) of the total input rating of all gas utilization equipment in the confined space, but not less than 100 square inches (645 cm²). One opening shall commence within 12" (305 mm) of the top, and one opening shall commence within 12" (305 mm) of the bottom of the enclosure. The minimum dimension of air openings shall be not less than 3" (76 mm) in any direction.

All Air from Outdoors

The confined space shall communicate with the outdoors in accordance with one of the methods below. The minimum dimension of air openings shall not be less than 3" (76 mm) in any direction. Where ducts are used, they shall be of the same cross-sectional area as the net free area of the openings to which they connect.

1. **Two permanent openings**, one commencing within 12" (305 mm) of the top, and one commencing within 12" (305 mm) of the bottom of the enclosure, shall be provided. The openings shall communicate directly, or by ducts, with the outdoors or spaces (crawl or attic) that freely communicate with the outdoors.
 - a. Where directly communicating with the outdoors or where communicating to the outdoors through vertical ducts, **each opening** shall have a minimum free area of 1 square inch per 4,000 BTUH (550 mm² per kW) of total input rating of all equipment in the enclosure.
 - b. Where communicating with the outdoors through horizontal ducts, **each opening** shall have a minimum free area of 1 square inch per 2,000 BTUH (1,100 mm² per kW) of total input rating of all equipment in the enclosure.
2. **One permanent opening**, commencing within 12" (305 mm) of the top of the enclosure, shall be permitted where the equipment has clearances of at least 1" (25.4 mm) from the sides and back and 6" (152 mm) from the front of the appliance. The opening shall directly communicate with the outdoors or shall communicate through a vertical or horizontal duct to the outdoors or spaces that freely communicate with the outdoors, and shall have a minimum free area of:

- a. 1 square inch per 3,000 BTUH (740 mm² per kW) of the total input rating of all equipment located in the enclosure, and
- b. Not less than the sum of the areas of all vent connectors in the confined space.

⚠ WARNING: Do not use the “one permanent opening” method if the equipment room is under negative-pressure conditions.

Canadian Installations

⚠ CAUTION: All combustion air must be drawn from the air outside of the building; the mechanical equipment room must communicate directly with the outdoors.

Ventilation of the space occupied by the boiler shall be provided by an opening(s) for ventilation air at the highest practical point communicating with the outdoors. The total cross-sectional area of such an opening(s) shall be at least 10% of the area required below, but in no case shall the cross-sectional area be less than 10 square inches (65 cm²).

⚠ WARNING: Make sure that the equipment room is not under negative-pressure conditions.

When air supply is provided by natural air flow from outdoors for a power burner and there is no draft regulator, draft hood or similar flue gas dilution device installed in the same space, in addition to the opening for ventilation air required above, there shall be a permanent air supply opening(s) having a total cross-sectional area of not less than 1 square inch for each 30,000 BTUH (74 mm² per kW) of total rated input of the burner(s), and the location of the opening(s) shall not interfere with the intended purpose of the opening(s) for ventilation air referred above.

This opening(s) can be ducted to a point not more than 18" (450 mm) nor less than 6" (152 mm) above the floor level. The duct can also “goose neck” through the roof. The duct is preferred to be straight down 18" (450 mm) from the floor, but not near piping. Refer to the B149 Installation Code for additional information.

Water Piping

General

The boiler should be located so that any water leaks will not cause damage to the adjacent area or structures.

NOTE: Minimum pipe size for the boiler inlet/outlet connections is dependent on the equivalent length of piping between the load loop and the boiler loop, the operating conditions and the size of the boiler. See Table I and Table J.

Low Water Cutoff

This boiler is equipped with a Low Water Cutoff as a standard feature. Some state and local codes require this as part of installation. Please be advised that some areas require both a low water cutoff and a flow switch. A flow switch is available as the F-1 sales option.

Relief Valve Piping

⚠ WARNING: Pressure relief valve discharge piping must be piped near the floor and close to a drain to eliminate the potential of severe burns. Do not pipe to any area where freezing could occur. Refer to local codes.

The pressure relief valve (PRV) is shipped loose in the Shipped Loose Items carton inside the crating.

All PRVs are shipped loose to protect them from damage during shipping/rigging into place.

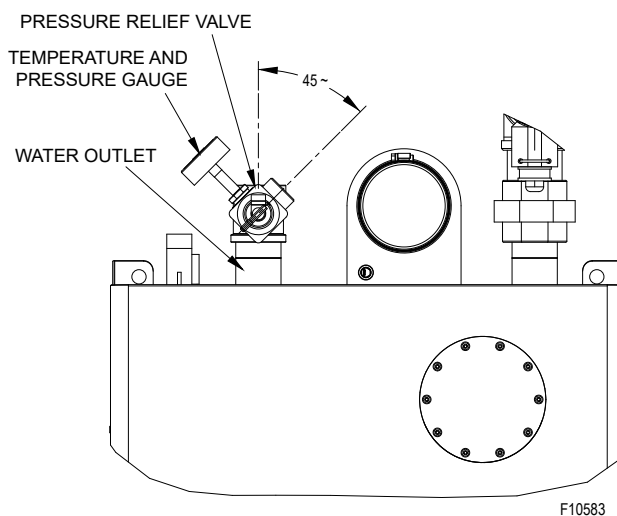

Figure 13. Recommended PRV Orientation

Temperature and Pressure Gauge

The temperature and pressure gauge is shipped loose.

Hydrostatic Test

Unlike many types of boilers, this boiler does not require hydrostatic testing prior to being placed in operation. The heat exchanger has already been factory-tested and is rated for 160 psi (1100 kPa) operating pressure. However, Raypak does recommend hydrostatic testing of the piping connections to the boiler and the rest of the system prior to operation. This is particularly true for hydronic systems using expensive glycol-based anti-freeze. Raypak recommends conducting the hydrostatic test before connecting gas piping or electrical supply. Leaks must be repaired at once to prevent damage to the boiler. NEVER use petroleum-based stop-leak compounds.

Isolate boiler water connections from the system prior to performing a hydrostatic test.

Flushing/Cleaning of System Piping

Many of the chemicals used to perform this function will harm the heat exchanger as well as some of the gaskets and seals within the unit, causing a non-warrantable failure. When required, Raypak recommends the boiler be isolated from the system piping prior to flushing or cleaning, using any cleaning agent.

System Sensor Installation

The System Sensor (S3) is required for all cascade or primary/secondary piping configurations unless the units firing rate will be controlled by an external source such as our Temp Tracker MOD+ Hybrid sequencer. Proper placement and method of installation are critical for proper operation of the system.

The sensor must be installed in a drywell in conjunction with heat conductive compound as shown in **Figure 14**. The drywell must be installed no more than 5 equivalent feet (1.52 m) of pipe/tubing downstream of the de-coupler and installed in such a way that ensures the sensor bulb is in the flow path on primary/secondary configurations or 5 equivalent feet (1.52 m) downstream of the last boiler in Primary Cascade systems.

CAUTION: Be careful when installing the drywell not to over-tighten the well as this can damage the well and may prevent the sensor from fitting properly.

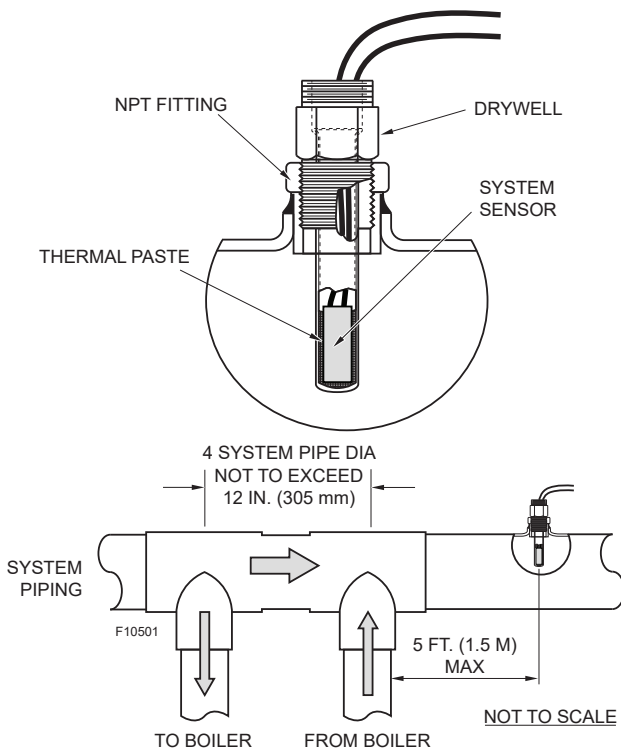

Figure 14. System Sensor Installation on Primary/Secondary Systems

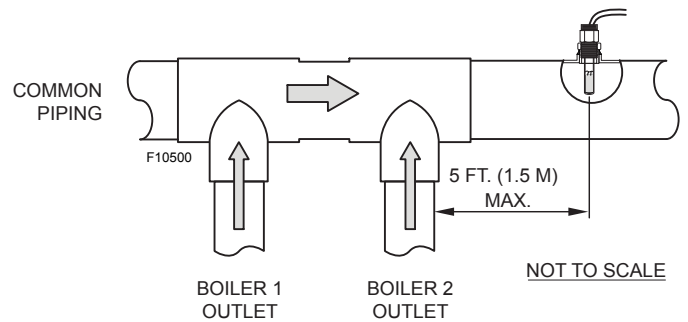

Figure 15. System Sensor Installation on Cascade Primary Systems

Hydronic Heating

Pump Selection

The boiler is designed for up to 75°F (24°C) ΔT and continuous return temperatures from 40°F to 190°F (4.4°C to 88°C).

NOTE: Higher return temperatures may limit the firing rate when the maximum water temperature of 200°F (93°C) is approached.

MODEL NO.	Flow Values GPM (lpm)			
	Max Flow**	Min Flow@ 100%*	Min Flow*	Min Flow with flow switch (optional)*
406L	73 (276)	11 (41)	6 (23)	15 (57)
506L	73 (276)	14 (53)	7 (26)	15 (57)
606L	73 (276)	16 (61)	8 (30)	15 (57)
726L	114 (431)	19 (72)	10 (38)	18 (68)
856L	114 (431)	22 (83)	11 (42)	18 (68)

* Minimum flow based on H₂O as heating media. Media other than H₂O may require higher minimum flow rates.

** Maximum flow based on 7.5 feet per second velocity.

Table G. Flow Rate Values

NOTE: For systems using glycol, see Table H below for necessary pumping requirements.

PARAMETER CORRECTION	Ethylene Glycol Concentration (%)				
	0	25	30	40	50
Capacity Factor Multiplier	1.000	0.972	0.960	0.928	0.878
GPM Correction Multiplier	1.000	1.040	1.055	1.100	1.150

Table H. Glycol Correction Factors

Feedwater Regulator

Raypak recommends that a feedwater regulator be installed and set at 12 psi (8.3 kPa) minimum pressure at the highest point of the system. Install a check valve or back flow device upstream of the regulator, with a manual shutoff valve as required by local codes.

Piping

All high points should be vented. This boiler, when used in connection with a refrigeration system, must be installed so that the chilled medium is piped in parallel with the boiler with appropriate valves to prevent the chilled medium from entering the boiler. The piping system of a hot water boiler connected to heating coils located in air-handling units where they may be exposed to circulating refrigerated air, must be equipped with flow-control valves or other automatic means to prevent gravity circulation of the boiler water during the cooling cycle. It is highly recommended that the piping be insulated.

Air-Separation/Expansion Tank

All boilers should be equipped with a properly-sized expansion tank and air separator fitted at the highest point in system.

Primary/Secondary Piping

NOTE: All hot water heating systems have unique levels of operating diversity that must be accounted for in the system design. The system should always include adequate system flow in excess of the connected boiler flow for proper operation of the primary/secondary system. Where the system flow may drop below the connected boiler flow a buffer/decoupler may be needed. Failure to design for adequate flow (i.e. bypasses, 3-way control valves, flow-limiting balance devices, buffer tanks, etc.) will result in boiler short-cycling and may reduce boiler life. Always contact your local Raypak representative for system design assistance to avoid these issues.

Applications and Modes - Primary/Secondary Piping

The VERSA IC[®] system is designed for a wide range of applications. The installer/design engineer should refer to the following Modes to determine which best fits the intended application and functionality for the unit being installed.

XVersL boilers have three modes available to them to address the various applications the units can be applied to. For detailed information on the VERSA IC[®] system, see the VERSA IC[®] Manual (241493). This manual can be found in the document library at www.raypak.com.

When installed in a primary/secondary piping system, the system flow must be at least 15% higher than the boiler flow.

Model No.	Input	Output	Min. Pipe Size Inches (mm)	20°F ΔT		30°F ΔT		40°F ΔT		60°F ΔT		Min. Flow for Full Fire (75°F ΔT)		Max. Flow	
	MBTUH (Kw/h)			GPM (L/min)	ΔP ft.hd. (kPa)	GPM (L/min)	ΔP ft.hd. (kPa)	GPM (L/min)	ΔP ft.hd. (kPa)	GPM (L/min)	ΔP ft.hd. (kPa)	GPM (L/min)	ΔP ft.hd. (kPa)	GPM (L/min)	ΔP ft.hd. (kPa)
406L	399 (117)	392 (115)	2 (50)	39 (148)	3.5 (10.5)	26 (98)	2.8 (8.4)	20 (76)	2.5 (7.5)	13 (49)	2.4 (7.2)	10 (38)	2.3 (6.9)	73 (276)	6.7 (20.0)
506L	500 (147)	489 (144)	2 (50)	49 (185)	4.8 (14.3)	33 (125)	3.4 (10.2)	24 (91)	2.9 (8.7)	16 (61)	2.5 (7.5)	13 (49)	2.4 (7.2)	73 (276)	6.7 (20.0)
606L	600 (176)	585 (172)	2 (50)	59 (223)	4.4 (13.2)	39 (148)	3.2 (9.6)	29 (110)	2.8 (8.4)	20 (76)	2.5 (7.5)	16 (61)	2.3 (6.9)	73 (276)	6.7 (20.0)
726L	725 (213)	705 (207)	2 1/2" (65)	71 (269)	4.9 (14.6)	47 (178)	3.5 (10.5)	35 (132)	3 (9.0)	24 (91)	2.7 (8.1)	19 (72)	2.6 (7.8)	114 (432)	8.7 (26.0)
856L	850 (250)	826 (243)	2 1/2" (65)	83 (314)	5.7 (17.0)	55 (208)	3.9 (11.7)	41 (155)	3.3 (9.9)	28 (106)	2.8 (8.4)	22 (83)	2.6 (7.8)	114 (432)	8.7 (26.0)

Pipe sizing based on not exceeding 7.5 feet per second velocity.
ΔP = Feet of Head.

Table I. Boiler Rates of Flow for Various System Pipe Sizes

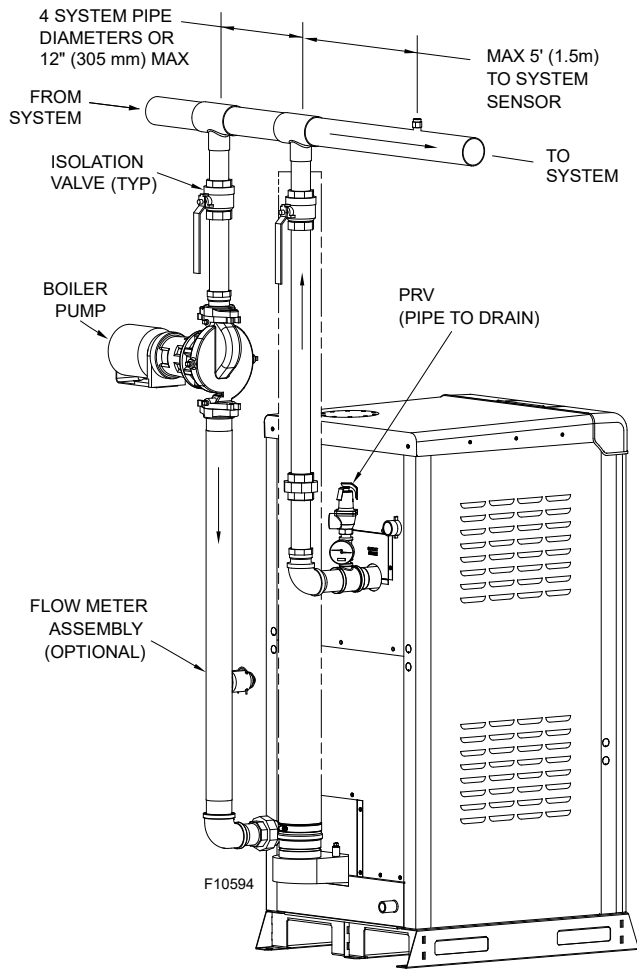

Figure 16. Hydronic Primary/Secondary Piping

Mode 1

This mode selection is for hydronic heating systems with single or multiple boilers in primary/secondary piping configuration with or without Outdoor Air Reset (S4). See **Figure 17** and **Figure 18**. (Illustration shows 4 boilers for reference only).

The system temperature is controlled by the System Sensor (S3), which must be installed less than 5 ft (1.5 m) downstream of the point where the boiler outlet rejoins the system piping. The Boiler Pump (P1) runs during any call for heat. The System Pump (P2) runs whenever the system is enabled for heating and the outdoor air temperature is lower than the warm weather shut down (WWSD) temperature setting (if utilized).

The Boiler Pump (P1) is delayed "Off" as user-defined in the BOILER menu and the System Pump (P2) is delayed "Off" in the ADJUST menu.

NOTE: See **VERSA IC® Manual (241493)** for more information on cascade systems.

NOTE: In cascade configuration, the system pump and DHW pump (if applicable) outputs from each cascade member must be connected in parallel to activate the system pump and DHW pump during "limp-along" operation respectively. See **VERSA IC® Manual (241493)** for detailed information.

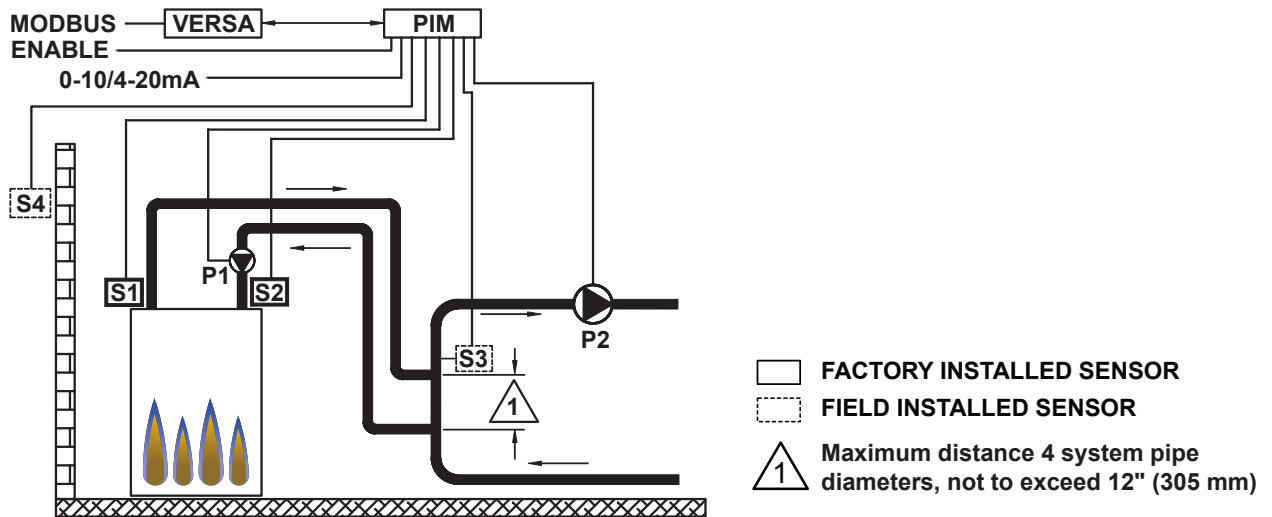

Figure 17. Mode 1 - Single Boiler with Primary/Secondary Piping

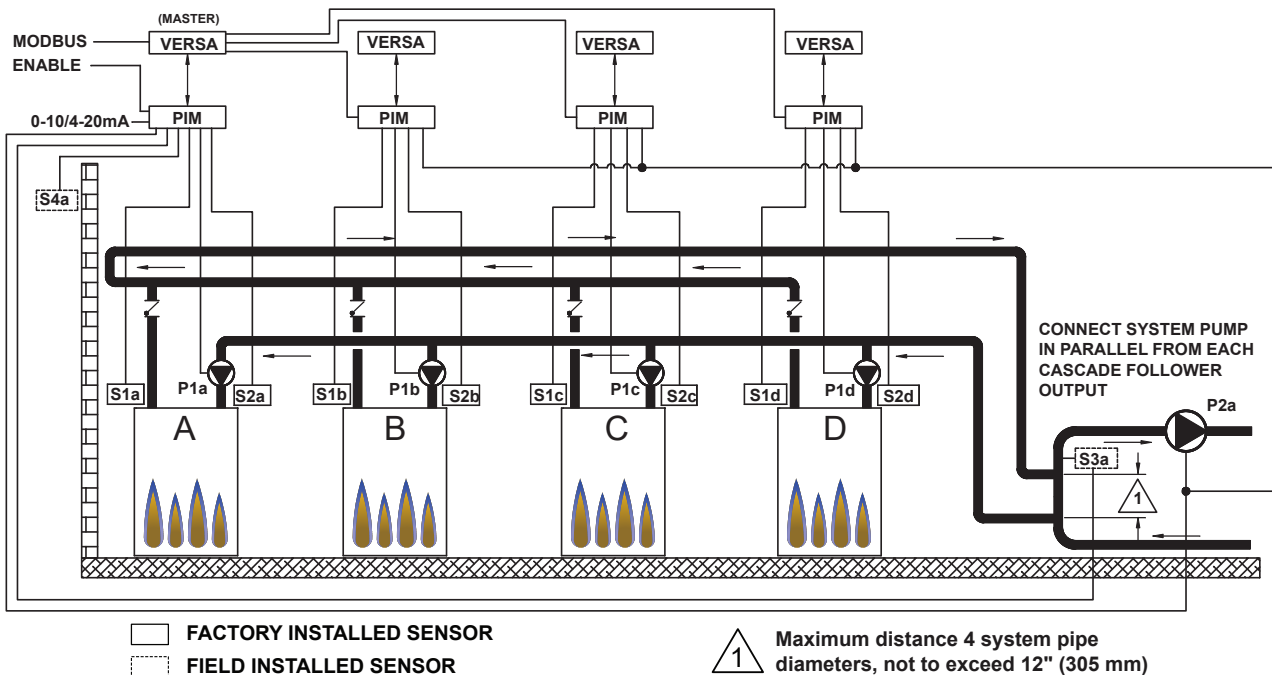

Figure 18. Mode 1 - Recommended Boiler Cascade with Primary/Secondary Piping

Mode 2

This mode selection is for hydronic heating systems with single or multiple boilers in primary/secondary piping configuration with or without Outdoor Air Reset (S4) with indirect DHW on the system loop (with or without priority). The system temperature is controlled by the System Sensor (S3), which must be installed less than 5 ft (1.5 m) downstream of the point where the boiler outlet rejoins the system piping. The Indirect DHW Sensor (S5) determines the indirect call/tank setpoint. See **Figure 19** and **Figure 20**. (Illustration shows 4 boilers for reference only).

The system temperature is boosted to Target Max when using the Indirect DHW Sensor (S5) during an indirect call for heat. Priority mode toggles off the System Pump (P2) when an indirect call for heat is present. The Boiler Pump (P1) runs during any call for heat. The Indirect DHW Pump (P3) runs during an indirect call for heat with no "Off" delay.

The Boiler Pump (P1) is delayed "Off" as user-defined in the BOILER menu and the System Pump (P2) is delayed "Off" in the ADJUST menu. The System Pump (P2) runs whenever the system is enabled for heating and the outdoor air temperature is lower than the WWSD temperature setting (if utilized) unless an indirect call for heat is present with priority.

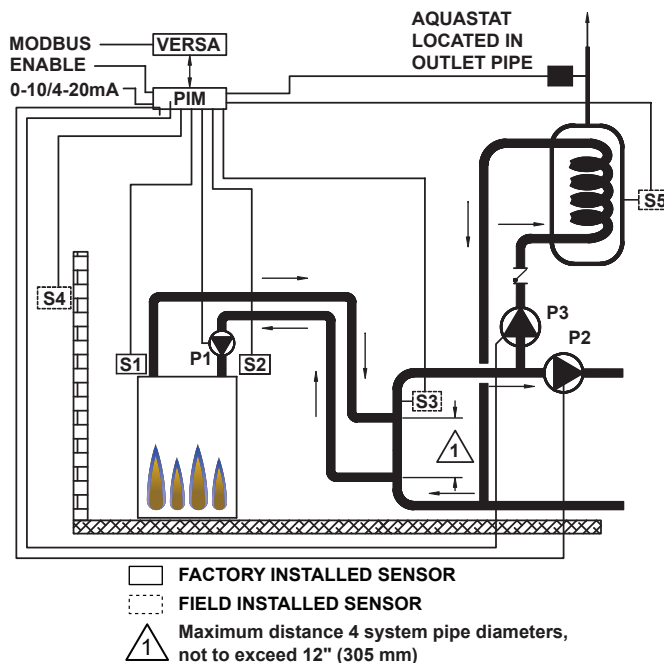

Figure 19. Mode 2 - Single Boiler with Indirect on System Loop - Primary/Secondary Piping

NOTE: See VERSA IC® Manual (241493) for more information on cascade systems.

NOTE: In cascade configuration, the system pump and DHW pump (if applicable) outputs from each cascade member must be connected in parallel to activate the system pump and DHW pump during "limp-along" operation respectively. See VERSA IC® Manual (241493) for detailed information.

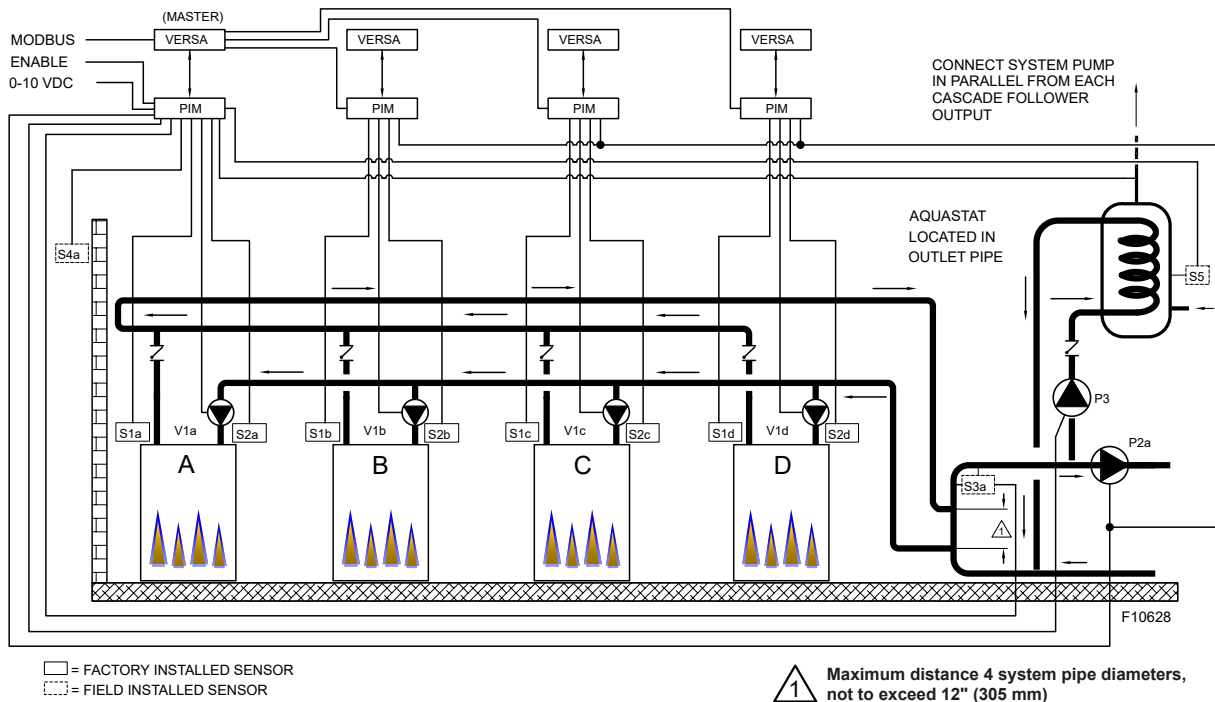

Figure 20. Mode 2 - Heater Cascade with Indirect on System Loop - Primary/Secondary Piping

Mode 3

This mode selection is for hydronic heating systems with single or multiple boilers in primary/secondary piping configuration with or without Outdoor Air Reset (S4) with indirect DHW on the boiler loop (with priority). See **Figure 21** and **Figure 22**. (Illustration shows 4 boilers for reference only). The system temperature is controlled by the Supply Sensor (S3). The S3 sensor must be installed less than 5 ft (1.5 m) downstream of the point where the boiler outlet rejoins the system piping. Whenever the

indirect call for heat is not active. The DHW Supply Sensor (S5) determines the indirect call/tank setpoint. During an indirect call for heat the boiler firing rate is determined by the water temperature at the Indirect Supply Sensor (S6) and the Target Max setting when using the Indirect DHW sensor (S5). The Boiler/Injection Pump (P1) runs during all heat calls regardless of priority. The Indirect DHW Pump (P3) runs during an indirect call for heat with no "Off" delay.

The Boiler/Injection Pump (P1) is delayed "Off" as user-defined in the BOILER menu and the System Pump (P2) is delayed "Off" in the ADJUST menu.

The System Pump (P2) runs whenever the system is enabled for heating and the outdoor air temperature is lower than the warm weather shut down (WWSD) temperature setting (if utilized) unless an indirect call for heat is present.

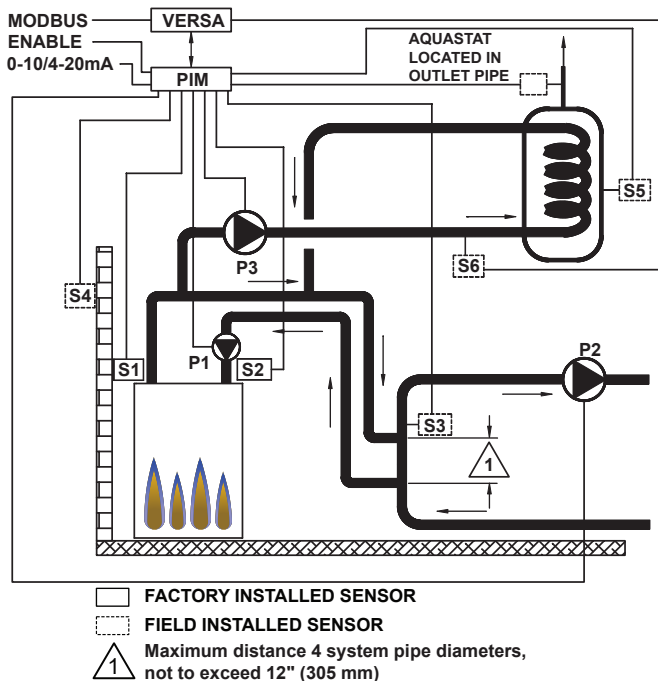

NOTE: A Tank Aquastat can be used in lieu of the Indirect DHW Sensor (S5). See VERSA IC® Manual (241493) for additional details.

NOTE: In cascade configuration, the system pump and DHW pump (if applicable) outputs from each cascade member must be connected in parallel to activate the system pump and DHW pump during "limp-along" operation respectively. See VERSA IC® Manual (241493) for detailed information.

Figure 21. Mode 3 - Single Boiler with Indirect on Boiler Loop Primary/Secondary Piping

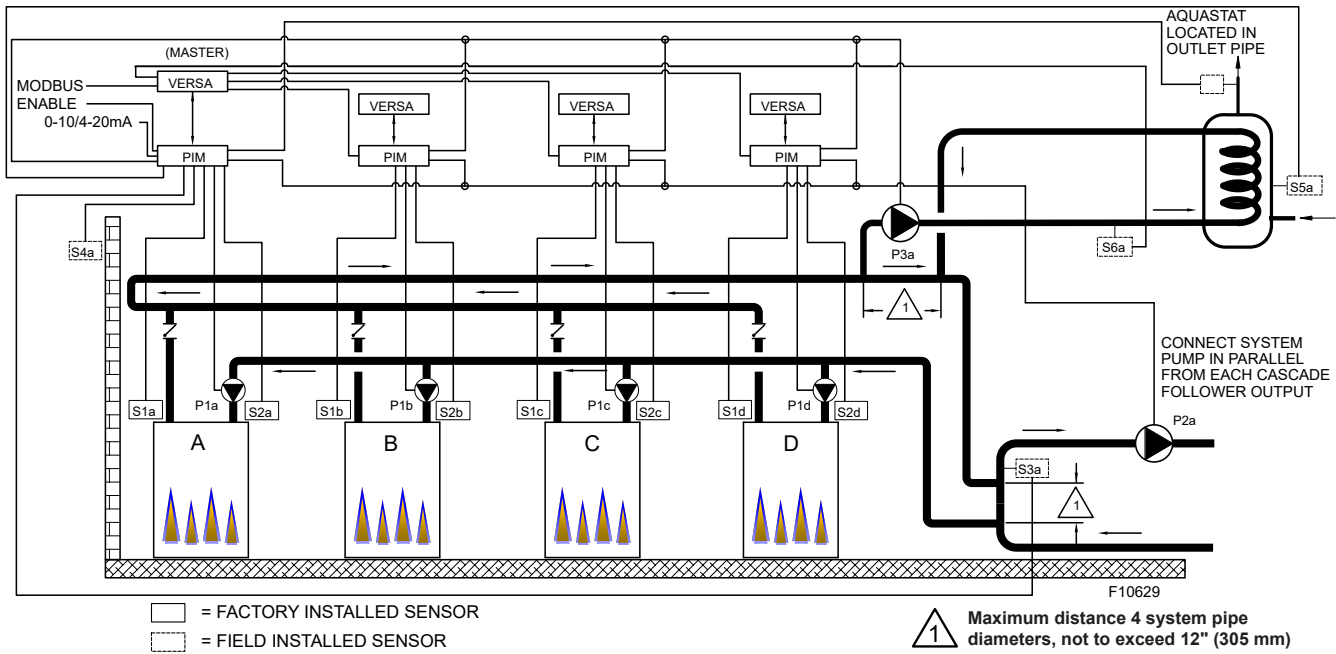

Figure 22. Mode 3 - Heater Cascade with Indirect on Heater Loop Primary/Secondary Piping

Applications and Modes - Primary Piping

The VERSA IC® system is designed for a wide range of applications. The installer/design engineer should refer to the following Modes to determine which best fits the intended application and functionality for the unit being installed. XVersL boilers have two operational modes available to them to address the various applications the units can be applied in Primary Piping configurations.

NOTE: Ensure PIM DIP#3 = OFF when isolation valves used on Primary Systems.

Mode 1

This mode selection is for hydronic heating systems with single or multiple boilers in primary piping configuration with or without Outdoor Air Reset (S4). See **Figure 24** and **Figure 25**. (Illustration shows 4 boilers for reference only).

For Single Boiler systems under primary piping configuration, the Outlet sensor (S1) can be used in lieu of the System Sensor (S3), although when S3 is connected the XVersL will use it for the system temperature. The isolation valve (V1) is expected to operate as a spring-open actuator. To close (turn OFF) the Isolation Valve (V1) the control applies power, to open (turn ON) the Isolation Valve (V1) the control will remove power to the isolation Valve (V1).

The Isolation Valve (V1) opens during any call for heat. The System Pump (P2) runs whenever the system is enabled for heating and the outdoor air temperature is lower than the warm weather shut down (WWSD) temperature setting (if utilized).

The Isolation Valve (V1) is delayed "OFF" as user-defined in the BOILER menu (Post purge) and the System Pump (P2) is delayed "OFF" in the ADJUST menu.

NOTE: In cascade configuration the system pump and DHW pump (if applicable) outputs from each cascade member must be connected in parallel to activate the system pump and DHW pump during "limp-along" operation respectively. See VERSA IC® Manual (241493) for detailed information.

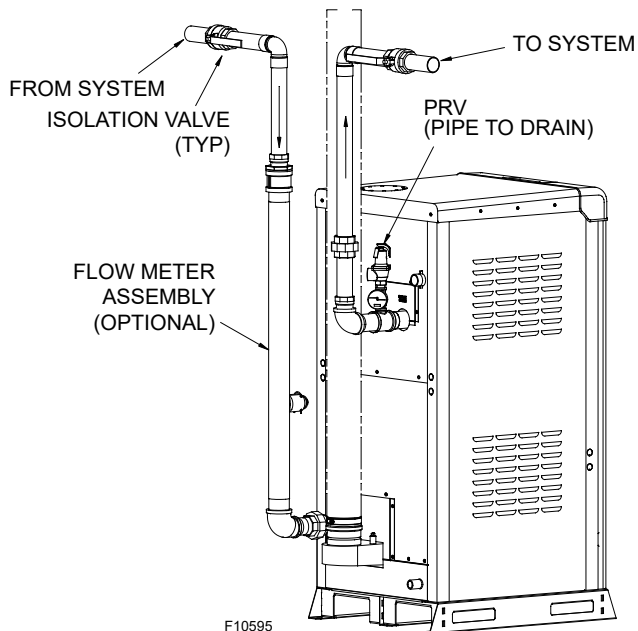

Figure 23. Hydronic Primary Piping

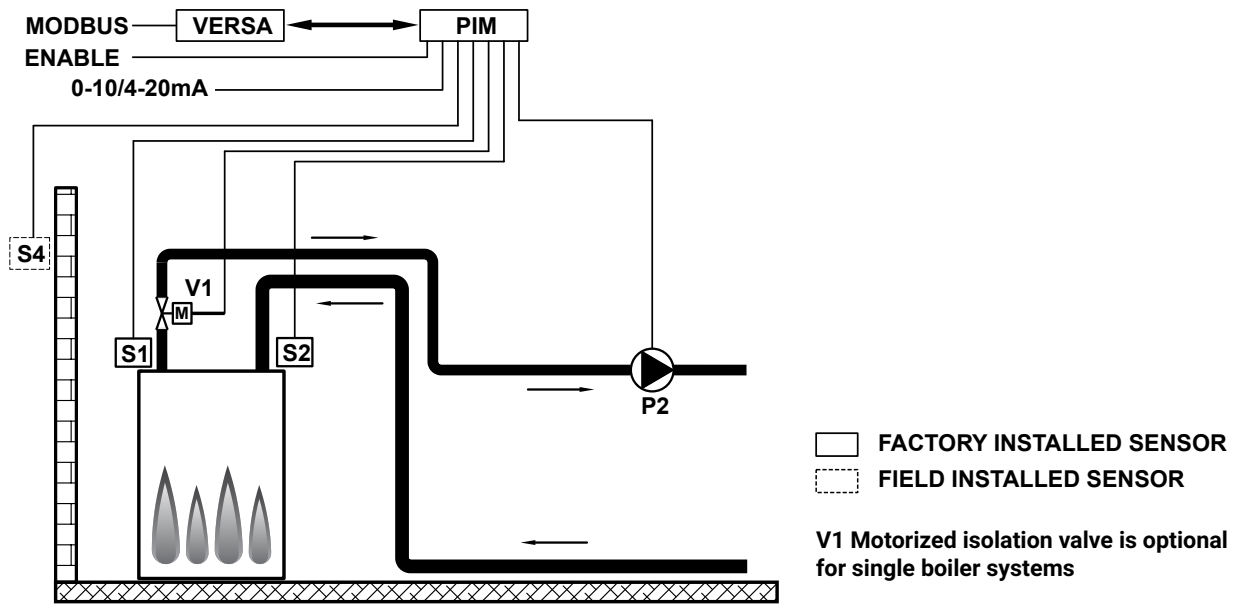

Figure 24. Mode 1 - Single Boiler with Primary Piping

NOTE: See VERSA IC[®] Manual (241493) for more information on cascade systems.

NOTE: XVersL boilers are equipped with a “pilot duty” dry contact to enable the system pump (P2a). In a cascade configuration it is recommended that all system pump outputs from each unit are connected in parallel to ensure proper operation of the system pump whenever flow path is present. Other piping arrangement and electrical configurations are suggested when it is not possible to synchronize the system pump operation with the boilers operation.

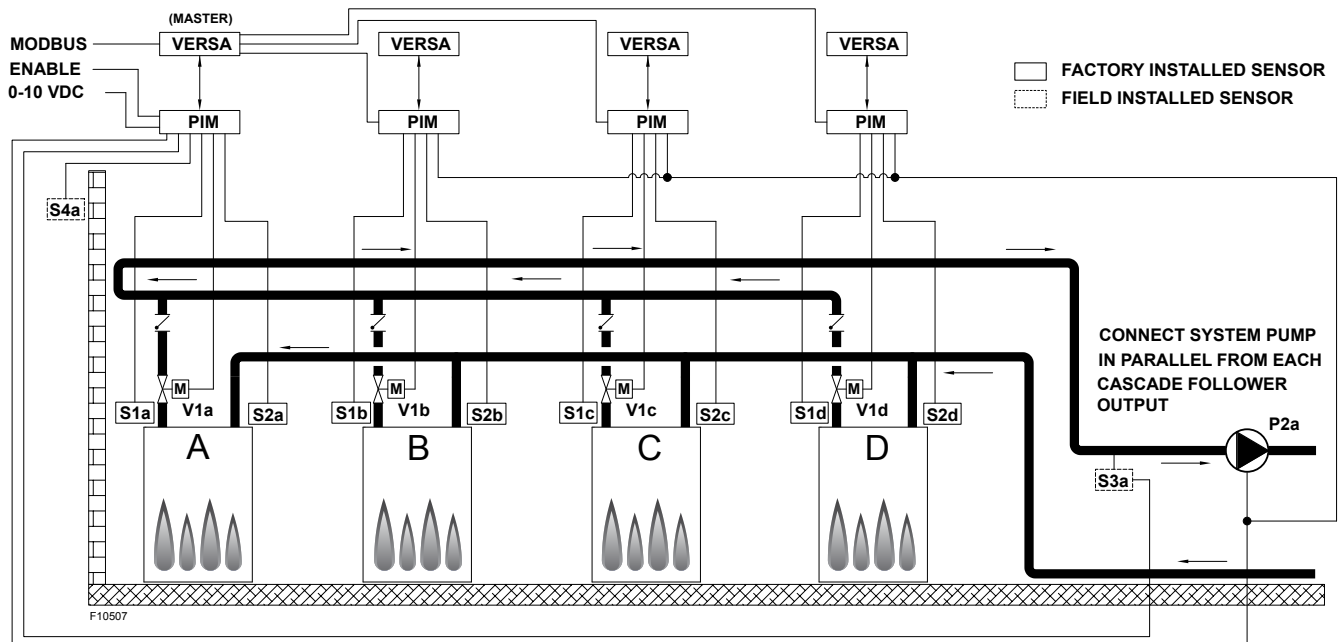

Figure 25. Mode 1 - Recommended Boiler Cascade with Primary Piping

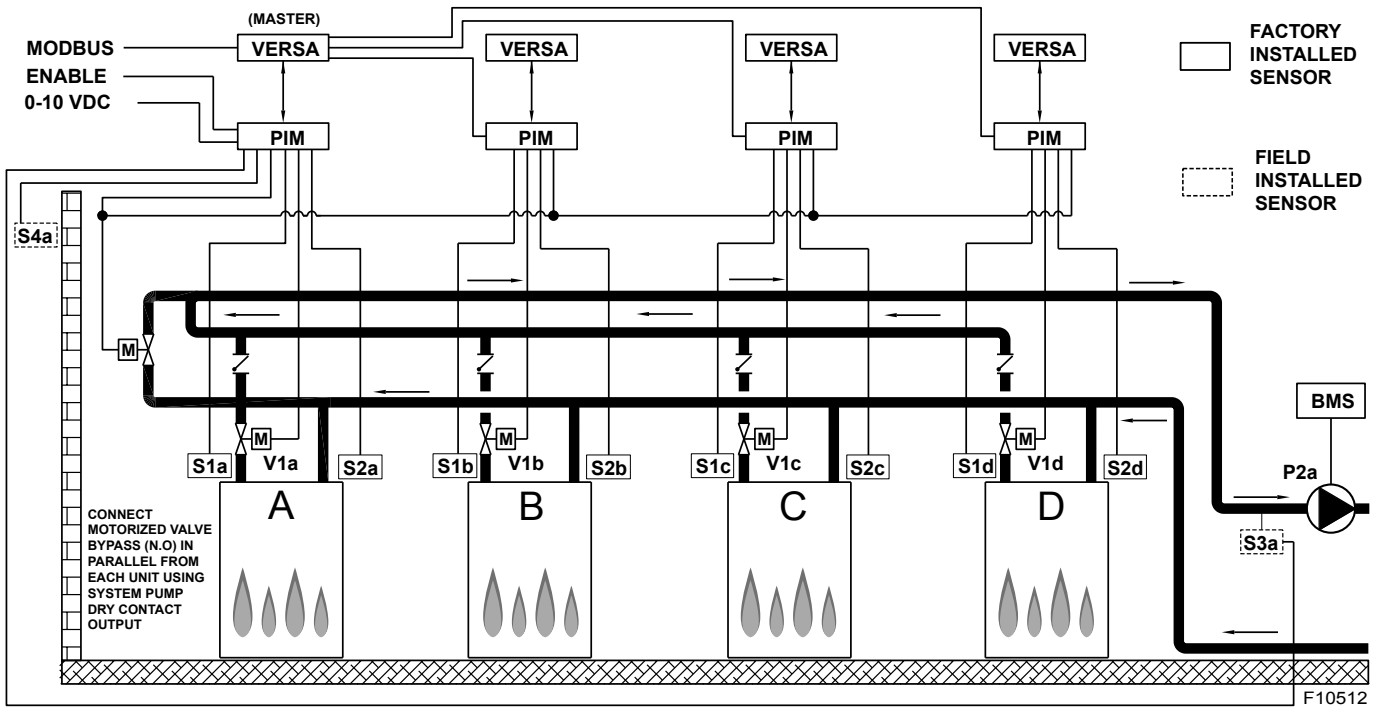

Figure 26. Boiler Cascade With Motorized Bypass Valve

NOTE: See VERSA IC® Manual (241493) for more information on cascade systems.

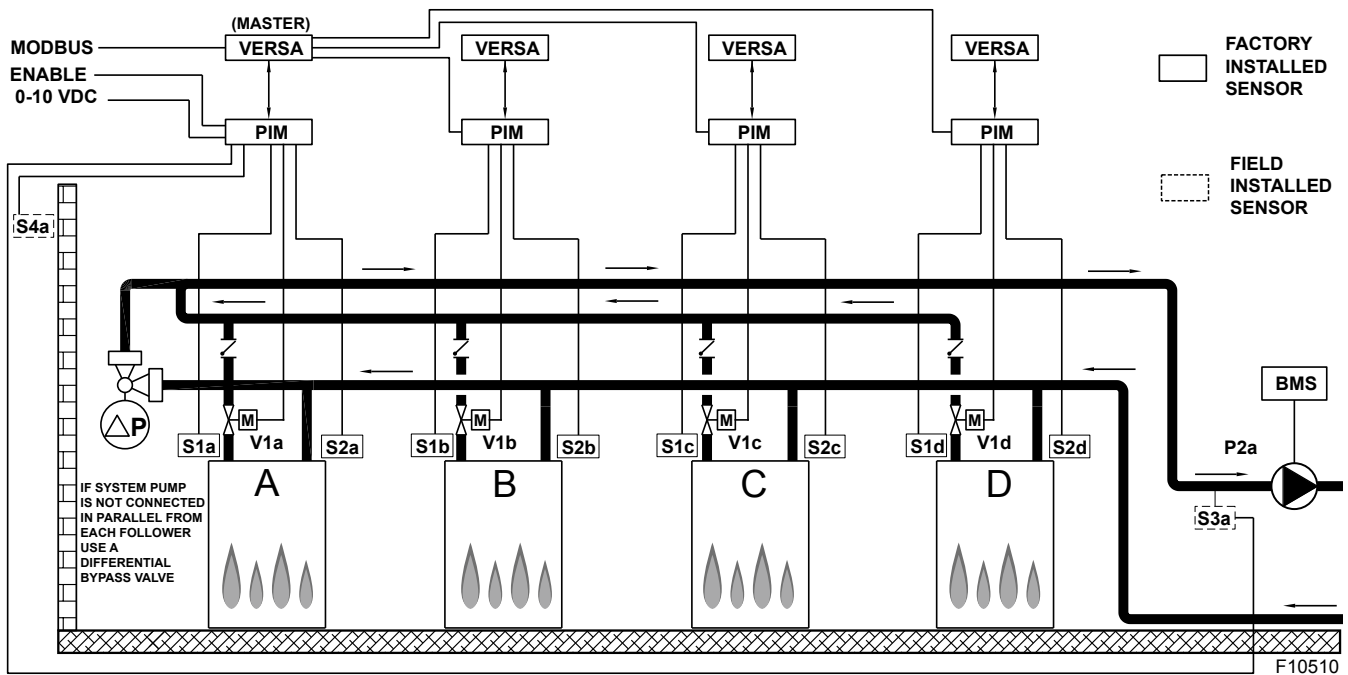

Figure 27. Boiler Cascade with Pressure Differential Bypass Valve - Primary Piping

Mode 2

This mode selection is for hydronic heating systems with single or multiple boilers in primary piping configuration with or without Outdoor Air Reset (S4) and with indirect DHW on the system loop (with or without priority). See **Figure 28**.

For Single Boiler systems under primary piping configuration, the Outlet Sensor (S1) can be used in lieu of the System Sensor (S3), although when S3 is connected the XVersL will use it for the system temperature. The Indirect DHW Sensor (S5) determines the indirect call/tank setpoint. The system temperature is boosted to Target Max when using the Indirect DHW Sensor (S5) during an indirect call for heat. Priority mode toggles off the System Pump (P2) when an indirect call for heat is present.

The Isolation Valve (V1) is expected to operate as a spring-open actuator. To close (turn OFF) the Isolation Valve (V1) the control applies power. To open (turn ON) the Isolation Valve (V1) the control will remove power to the isolation valve (V1). The Isolation Valve (V1) opens during any call for heat. The Indirect DHW Pump (P3) runs during an indirect call for heat with no "OFF" delay.

The Isolation Valve (V1) is delayed "OFF" as user-defined in the BOILER menu (Post purge) and the System Pump (P2) is delayed "OFF" in the ADJUST menu. The System Pump (P2) runs whenever the system is enabled for heating and the outdoor air temperature is lower than the WWSD temperature setting (if utilized) unless an indirect call for heat is present with priority.

NOTE: In cascade configuration, the system pump and DHW pump (if applicable) outputs from each cascade member must be connected in parallel to activate the system pump and DHW pump during "limp-along" operation respectively. See VERSA IC[®] Manual (241493) for detailed information.

Automatic Chemical Feeders

All chemicals must be completely diluted into the water before being circulated through the boiler. High chemical concentrations will result when the pump is not running (e.g. overnight).

CAUTION: Combustion air must not be contaminated by corrosive chemical fumes which can damage the boiler and void warranty.

CAUTION: High chemical concentrations from feeders that are out of adjustment will cause rapid corrosion to the heat exchanger. Such damage is not covered under the warranty.

CAUTION: Failure of a heat exchanger due to lime scale build-up on the heating surface, low pH, or other chemical imbalance is not covered under the warranty.

Gas Supply

DANGER: Make sure the gas on which the boiler will operate is the same type as specified on the boiler's rating plate.

A pounds-to-inches regulator of the lock-up type must be installed to reduce the gas supply pressure if it is higher than 10.5" WC for natural gas or 13" WC for propane gas. This regulator should be installed following the regulator manufacturers instructions refer to **Table J** for maximum pipe lengths.

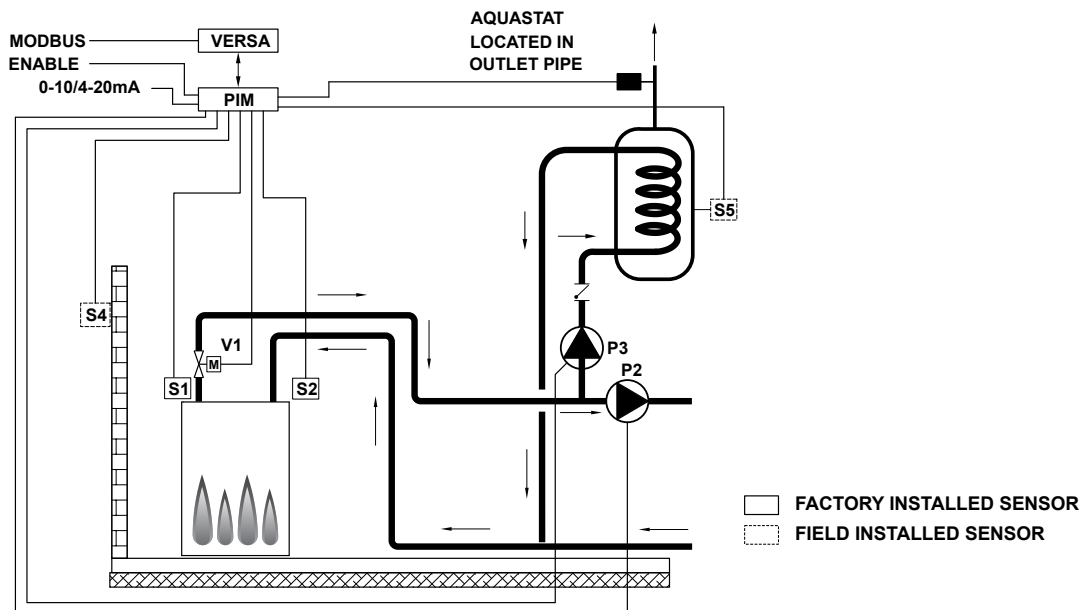

Figure 28. Mode 2 - Single Boiler with Indirect - Primary Piping

Gas Supply Connection

A manual shutoff valve located outside the boiler jacket is required to be field supplied.

CAUTION: The boiler must be disconnected from the gas supply during any pressure testing of the gas supply system at test pressures in excess of 1/2 psi (3.45 kPa).

The boiler must be isolated from the gas supply piping system by closing the upstream manual shutoff valve during any pressure testing of the gas supply piping system at test pressures equal to or less than 1/2 psi (3.45 kPa). Relieve test pressure in the gas supply line prior to re-connecting the boiler and its manual shutoff valve to the gas supply line. **FAILURE TO FOLLOW THIS PROCEDURE MAY DAMAGE THE GAS VALVE.** Over-pressurized gas valves are not covered by warranty. The boiler and its gas connections shall be leak-tested before placing the appliance in operation. Use soapy water for leak test. DO NOT use an open flame.

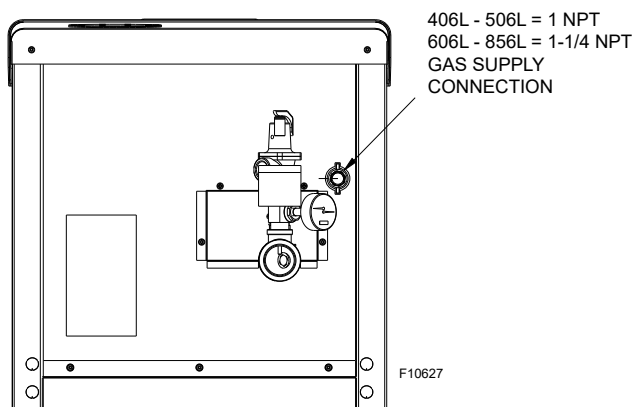

Figure 29. Gas Supply Connection

CAUTION: Only sealant tape or a pipe compound rated for use with natural and propane gases is recommended. Apply sparingly only on male pipe ends, leaving the two end threads bare.

CAUTION: Support gas supply piping with hangers, not by the boiler or its accessories. Make sure the gas piping is protected from physical damage and freezing, where required.

NOTE: Install proper dripleg per National Fuel Gas Code.

Gas Supply Pressure

A minimum of 4" WC and a maximum of 10.5" WC gas pressure is required under load and no-load conditions for natural gas at the boiler. A minimum of 4" WC and a maximum of 13" WC is required for propane gas at the boiler. The gas pressure regulator(s) supplied on the boiler is for low-pressure service. If upstream pressure exceeds these values, an intermediate gas pressure regulator, of the lockup type, must be installed.

When connecting additional gas utilization equipment to the gas piping system, the existing piping must be checked to determine if it has adequate capacity for the combined load.

CAUTION: For proper operation, no more than a 30% drop in gas supply pressure from no-load to full-load conditions is acceptable. Under no circumstances should the pressure be outside the listed operational range.

Model No.	1" NPT (ft./m)		1-1/4" NPT (ft./m)		1-1/2" NPT (ft./m)		2" NPT (ft./m)	
	Nat	Pro	Nat	Pro	Nat	Pro	Nat	Pro
406L	25 (8)	80 (24)	100 (30)	375 (114)	200 (61)	650 (198)		
506L	15 (5)	40 (12)	65 (20)	250 (76)	150 (46)	450 (137)		
606L			45 (14)	175 (53)	100 (30)	350 (107)	325 (99)	975 (297)
726L			35 (11)	100 (30)	70 (21)	275 (84)	250 (76)	725 (221)
856L			25 (8)	70 (21)	50 (15)	175 (53)	175 (53)	550 (168)

Natural gas - 1,000 btu/ft³, 0.60 specific gravity at 0.5" W.C. pressure drop
 Propane gas - 2,500 btu/ft³, 1.53 specific gravity at 0.6" W.C. pressure drop
 Lengths based on Sched 40 BIP - for other materials consult local codes
 Each elbow counts as 10 ft equivalent pipe length

Table J. Gas Supply Piping - Max. Equivalent Length

Electrical Power Connections

⚠ WARNING: Boiler is designed for factory installed 120V or factory installed 208V. See details in "Multiple Voltage Configurations" on page 26.

⚠ WARNING: Electrical power connection must be performed by qualified licensed electrician(s) for the voltage being applied.

Installations must follow these codes:

- National Electrical Code and any other national, state, provincial or local codes or regulations having jurisdiction.
- Safety wiring must be NEC Class 1.
- Heater must be electrically grounded as required by the NEC.
- In Canada, CSA C22. 1 C.E.C. Part 1.

NOTE: A 120VAC (0.75A Max.) outlet is provided on the bottom of the Junction Box for general use.

Before starting the boiler, check to ensure proper voltage to the boiler.

Pumps (if used) must use a separate power supply and run the power through a field-supplied contactor. Use appropriately-sized wire as defined by NEC, CSA and/or local codes. All primary wiring should be 125% of minimum rating.

If any of the original wire as supplied with the boiler must be replaced, it must be replaced with 105°C wire or its equivalent.

All high voltage wiring connections to the XVersL boiler are made inside the wiring box as shown in **Figure 30** and **Figure 31**. There are three factory-supplied interlock relays in the rear wiring box to provide an enable signal via dry contacts (pilot duty) for the Boiler Pump/Isolation Valve, System Pump, and Indirect DHW Pump as required for the system depending on the mode selected within the VERSA IC® system.

Model No.	Boiler Current Draw	
	120VAC	208VAC
406L	<7.5 A	<5.0 A
506L	<5.0 A	<5.0 A
606L	<5.0 A	<5.0 A
726L	<5.0 A	<5.0 A
856L	<7.5 A	<7.5 A

Single phase power. Current draw is for boiler only (supply breaker must have delayed trip).

Table K. Expected Boiler Amp Draw

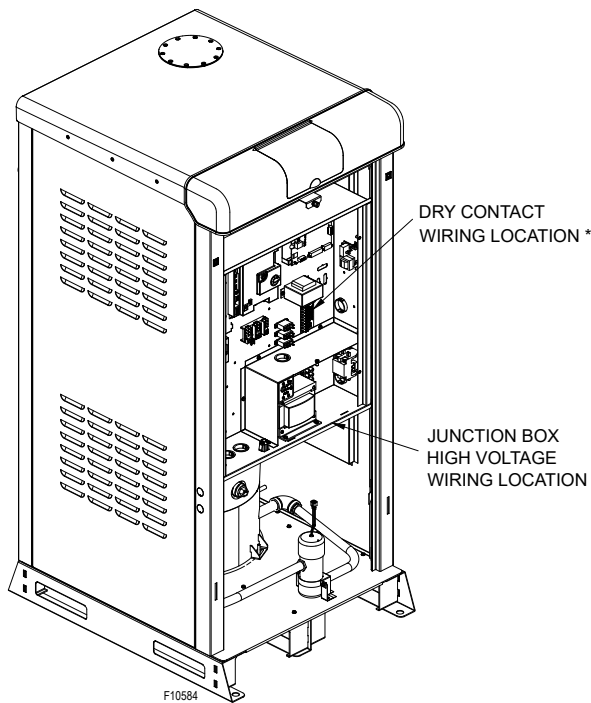

* See Figure 31.

Figure 30. Wiring Box Location

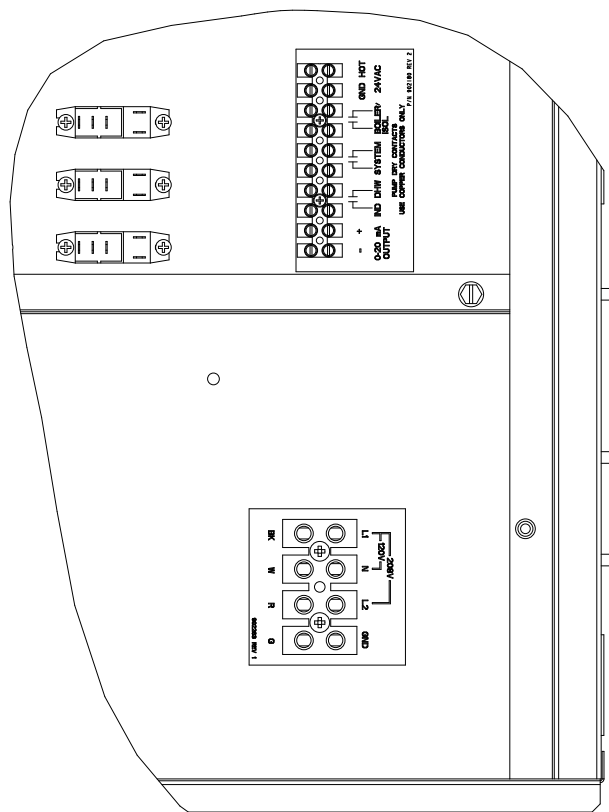

Figure 31. Wiring Electrical Connections

Multiple Voltage Configurations

The XVersL product can be configured to operate on either 120VAC or 208VAC power.

Unit Size	Input Voltage	See "WIRING DIAGRAM" on page 57.
All models	120V, No transformer	
	208V, Has transformer	

Table L. Voltage Configurations

NOTE: 24VAC is available at the wiring box to be used for the Isolation valve actuation.

Check Power Source

WARNING: Using a multimeter, check the following voltages at the circuit breaker panel prior to connecting any equipment. Make sure measurement is performed between proper hot lines and/or neutral lines.

Figure 32 represents the most common WYE configuration at the main power supply from the building circuit breaker for 120 or 208 VAC.

Making the Electrical Connections

1. Verify that circuit breaker is properly sized by referring to boiler rating plate. A dedicated circuit breaker shall be provided.
2. Observe proper wire colors while making electrical connections. Many electronic controls are polarity sensitive. Components damaged by improper electrical installation are not covered by warranty.
3. Provide overload protection and a disconnect means for equipment serviceability as required by local and state code.
4. Conduit shall not be used as the earth ground.

NOTE: A grounding electrode conductor shall be used to connect the equipment grounding conductors, the equipment enclosures, and the grounded service conductor to the grounding electrode.

Field-Connected Devices

Field Wiring Connection

Field-Connected Devices

It is strongly recommended that all individually-powered control modules and the boiler should be supplied from the same power source.

Install boiler controls, thermostats, or building management systems in accordance with the applicable manufacturers' instructions.

DANGER: SHOCK HAZARD

CAUTION: Label all wires prior to disconnection when servicing controls. Wiring errors can cause improper and dangerous operation. Verify proper operation after servicing.

NOTE: Minimum 18 AWG, 105°C, stranded wire must be used for all low voltage (less than 30 volts) external connections to the boiler. Solid conductors should not be used because they can cause excessive tension on contact points. Install conduit as appropriate. All high voltage wires must be the same size (105°C, stranded wire) as the ones on the unit or larger.

Make sure electrical power to the boiler is disconnected to avoid potential serious injury or damage to components.

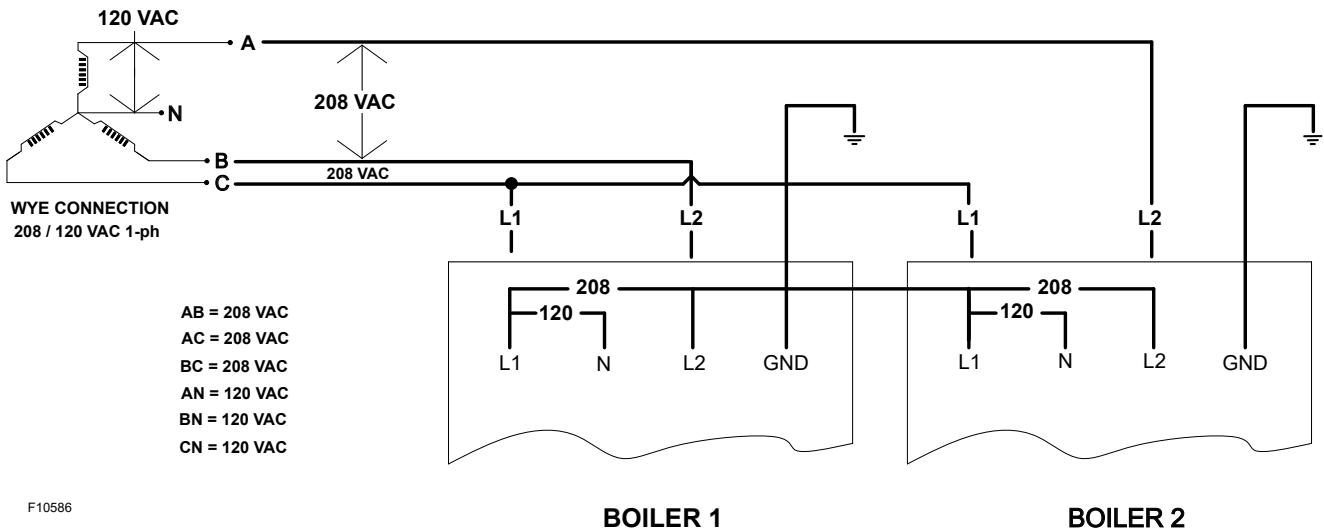

Figure 32. WYE Electrical Connections for 120/208 VAC

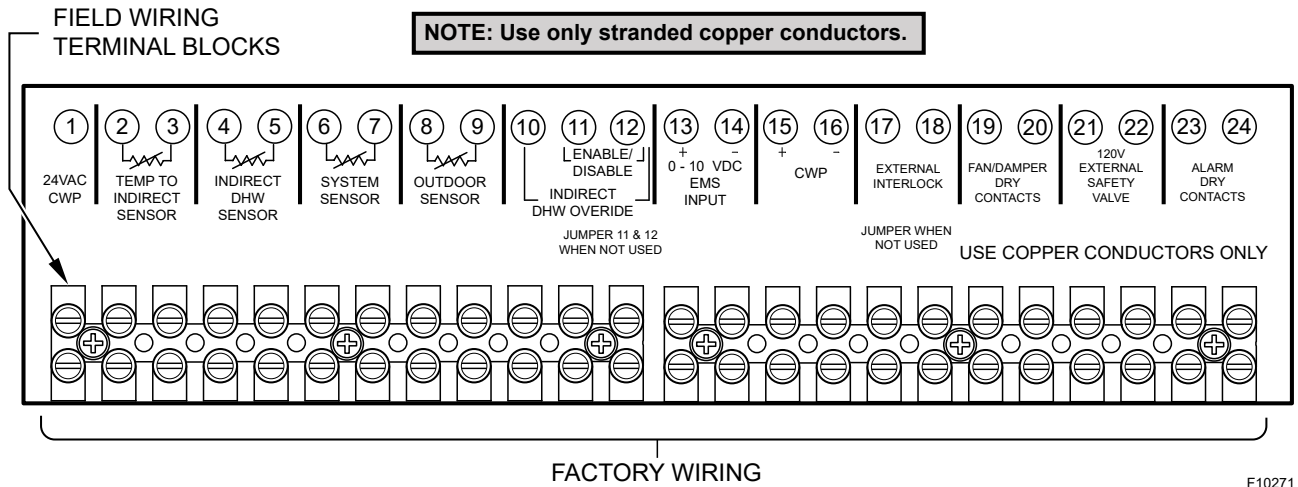

Figure 33. Low-Voltage Field Wiring

F10271

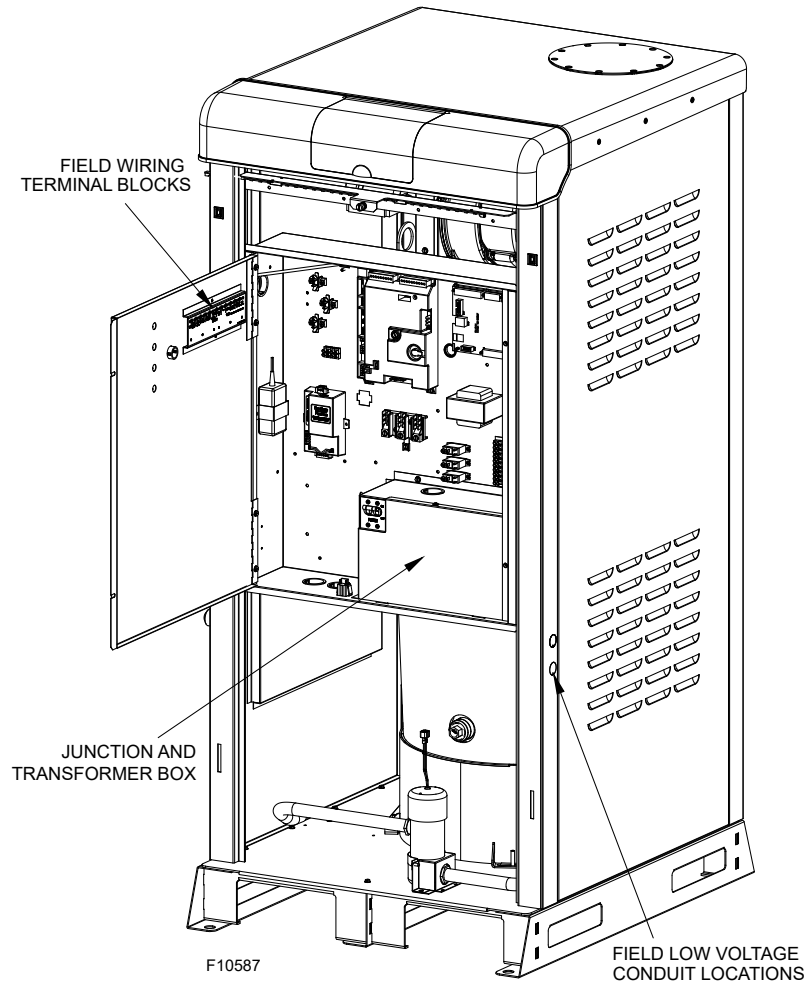

Figure 34. Low-Voltage Wiring/Transformer Box

Wiring the Optional 0–10 Volt Building Control Signal

1. A signal from an energy management system may be connected to the XVersL boiler. This signal should be a 0-10 volt positive DC signal. The energy management system can be used to control either the setpoint temperature of a single XVersL or a cascade configuration (refer to the VERSA IC® Manual 241493 for details), or the firing rate of a single XVersL boiler.
2. To enable this remote control function, set DIP switch 5 to the UP position on the PIM. DIP switch 5 Toggles between an EMS (UP) signal or a demand signal from the VERSA (DOWN). DIP switch 2 on the PIM toggles between a Direct Drive (UP) input and a Target Temperature (DOWN) setpoint.
3. For a 4-20mA application, refer to the VERSA IC® Manual (241493).
4. Connect an Energy Management system or other auxiliary control signal to the terminals marked 0-10V (+/-) on the field wiring terminals. See **Figure 33**. Caution should be used to ensure that the +0-10V connection does not create a short to ground.
5. Contact closure across the Enable/Disable connection is required for boiler operation in this configuration.

CAUTION: Ensure that the +0-10V connection does not create a short to ground. +0-10V signal is polarity sensitivity and must not be reversed. +0-10VDC signal must not exceed 10VDC.

Wiring the Enable/Disable

Connect the Enable/Disable (terminals 11, 12) wiring to the field wiring terminals as shown in **Figure 33** and in place of the factory installed jumper. Alternately, any dry contact closure (including a remote thermostat) across these terminals will enable the XVersL boiler to run.

CAUTION: Ensure neither of the terminals are shorted to ground.

The 3-position rocker switch (adjacent to the touchscreen user interface) must be in the "RUN" position for the boiler to operate when enabled.

CAUTION: The Enable/Disable signal may be overridden when the VERSA control is configured for MODBUS "TEMP" or "RATE". Disable MODBUS prior to servicing the boiler.

Wiring the System Sensor (S3)

NOTE: The System Sensor (S3) is not required for single unit Primary piping configuration.

The System Sensor is required for all Primary/Secondary and all cascade configurations for all selectable modes unless the unit's firing rate will be controlled by an external source, such as our TempTracker MOD+ Hybrid sequencer. Proper placement and method of installation are critical for proper operation of the system. See "Applications and Modes".

1. When using a System Sensor, connect the sensor wires to the terminals marked (6, 7) SYSTEM SENSOR. See **Figure 33**.
2. Use a minimum of 18 AWG stranded wire for runs up to 150' (46 m).
3. Install the system sensor in a drywell (option B-31) within 5 feet (1.5 m) downstream of the de-coupler (primary/secondary system) or last boiler (primary). See **Figure 14** or **Figure 15** as appropriate.

Wiring the Outdoor Sensor (S4)

1. If using an Outdoor Sensor, connect the sensor wires to the terminals (8 and 9) marked OUTDOOR SENSOR. See **Figure 33**.

CAUTION: Ensure sensor wiring is not shorted to ground.

2. Use a minimum 18 AWG stranded wire for runs of up to 150 feet (46 m).
3. Mount the outdoor sensor on an exterior surface of the building, preferably on the north or west facing side in an area that will not be affected by direct sunlight.

Wiring a Boiler Pump

When applicable, connect the boiler pump enable wiring to the field-wiring terminal block inside the junction box. The connections are dry contacts rated for pilot duty only (5A maximum). See **Figure 35** for details.

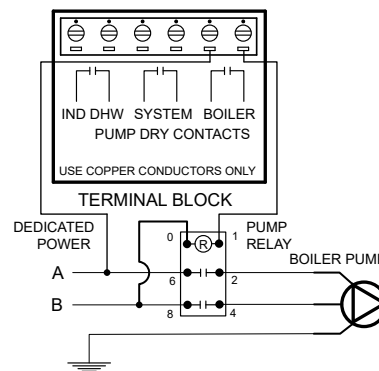

Figure 35. Boiler Pump Wiring

NOTE: Follow same wiring for single boiler and standalone system pump operation using "system pump dry contacts"

Variable-Speed Pump Signal

The XVersL products are equipped with an analog output that is proportional to the firing rate of the boiler. This 0-20mA signal is intended to be used for an external Variable-Speed pump as part of a Primary/Secondary piping system. See **Figure 36**.

This output can also be configured for 0-10 VDC using an appropriate resistor connected in parallel between the output terminals. Easy access to the terminals can be found in the wiring box. See **Figure 3**.

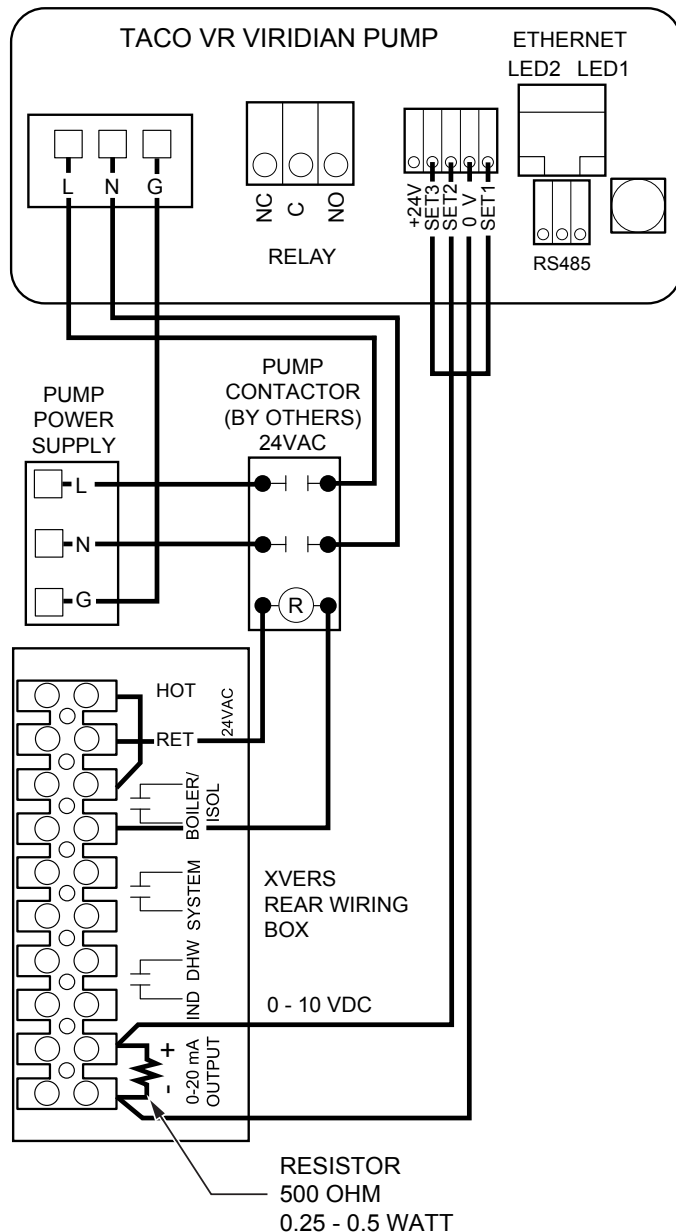

Figure 36. Variable Speed Pump Wiring Diagram

Wiring the Indirect DHW Sensor (S5) (Optional)

Connect the indirect tank sensor to the terminals (4 and 5) marked INDIRECT DHW SENSOR. See **Figure 33**. Caution should be used to ensure neither of these terminals becomes connected to ground. When using an indirect DHW Sensor to control tank temperature, contact closure is required across the indirect override connections for proper operation.

NOTE: Alternately, a thermostat contact closure can be used in lieu of the sensor for indirect operation. Connect the thermostat to the terminals (10 and 12) marked INDIRECT DHW OVERRIDE.

When the Indirect DHW call for heat is active, the PIM communicates this to the VERSA. The VERSA calculates the optimal operation and sends the firing rate and pump output requests to the PIM so it can activate the Indirect DHW Pump and Boiler Pump as needed.

If optional Indirect DHW Sensor is connected, the PIM will pass this signal to the VERSA. This allows the VERSA to optimize the Indirect DHW demand to maintain the Indirect DHW setpoint. The Indirect DHW thermostat switch closure is still required when using the Indirect DHW Sensor. If a VERSA is not present, the PIM shall activate the Indirect DHW pump whenever the Indirect DHW call is active. The Boiler pump will also be activated based on the Indirect DHW piping configuration setting.

CAUTION: To prevent an over-temperature condition from occurring in the indirect DHW system during "limp-along" operation, set PIM operator dial to be equal to DHW Target temperature. See VERSA IC® Manual (241493) for more information on "limp-along" operation.

CAUTION: Sensor and control wiring must NOT be run in chases with line voltage.

Wiring the Temp to Indirect Sensor (S6)

Connect the temp to indirect sensor to the terminals (2 and 3) marked INDIRECT DHW SENSOR. Refer to the VERSA IC® Manual. Caution should be used to ensure neither of these terminals becomes connected to ground. When using the Temp to Indirect Sensor to control the temperature of the Indirect DHW tank, contact closure is required across the indirect override connections for proper operation.

NOTE: Alternately, a thermostat contact closure can be used in lieu of the sensor for indirect operation. Connect the thermostat to the terminals (10 and 12) marked INDIRECT DHW OVERRIDE.

When the Indirect DHW call for heat is active, the PIM communicates this to the VERSA. The VERSA calculates the optimal operation and sends the firing rate and pump output requests to the PIM so it can activate the Indirect DHW Pump and Boiler Pump as needed. If optional Indirect DHW Sensor is connected, the PIM will pass this signal to the VERSA. This allows the VERSA to optimize the Indirect DHW demand to maintain the Indirect DHW setpoint. The Indirect DHW thermostat switch closure is still required when using the Temp to Indirect Sensor. If a VERSA is not present, the PIM shall activate the Indirect DHW pump whenever the Indirect DHW call is active. The Boiler pump will also be activated based on the Indirect DHW piping configuration setting.

CAUTION: Sensor and control wiring must NOT be run in chases with line voltage.

CAUTION: To prevent an over-temperature condition from occurring in the indirect DHW system during "limp-along" operation, set PIM operator dial to be equal to DHW Target temperature. See VERSA IC® Manual (241493) for more information on "limp-along" operation.

Wiring the Cascade System - Communication Bus

Refer to VERSA IC® Manual (241493) for details on Cascade wiring and communication setup.

Cascade System Pump and Sensor Wiring

1. On the boiler designated as the Master, connect the system pump enable wiring to the field-wiring terminal block inside the junction box. The connections are dry contacts rated for pilot duty only (5A maximum).
2. Connect the system supply sensor to terminals 6 and 7 on the field wiring strip located on the Master boiler. See **Figure 33**.
3. Connect the Outdoor sensor (if used) to terminals 8 and 9 on the field wiring strip located on the Master boiler. See **Figure 33**.
4. Connect the Enable/Disable wiring to terminals 11 and 12 on the field wiring strip located on the Master boiler. This connection must be provided through dry contacts closure. See **Figure 33**. Applying 24VAC to these terminals will result in blowing the fuse on PIM.

NOTE: The dry contacts closure can come from a room thermostat or a remote relay. No power of any kind should be applied to either of these terminals.

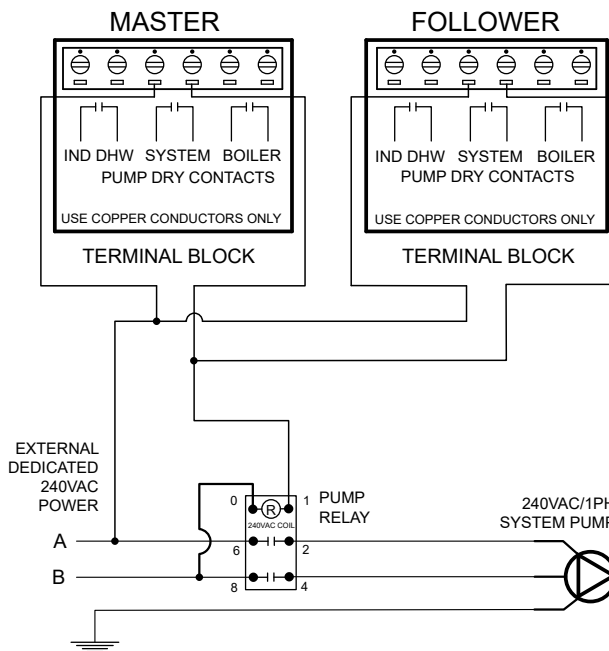

Figure 37. XVersL Cascade System Pumps (240VAC Shown)

Cascade Follower Pump and Sensor Wiring

1. Once the primary boiler has been identified, additional boilers will be designated as follower boilers. Ensure DIP switch 2 on each follower VERSA is set to the OFF/Down position.
2. For Cascade configurations System pump and DHW pump, Follower outputs must be connected in parallel respectively in order to support operation during "limp-along" operation.

Modbus BMS Communication

The VERSA IC® is equipped as standard with a communications port for connectivity to building automation via Modbus protocol.

Refer to the VERSA IC® Manual (241493) for further information. The XVersL may be equipped with protocol converter. See ProtoNode Manual (241515) and wiring diagram.

Alarm Connection

An alarm annunciator or light may be connected to the alarm contacts on the field wiring terminal strip.

The Alarm Contacts are 3A rated dry contacts on a normally-open relay that close during fault or lockout conditions, and the maximum voltage across the contacts is 30 VAC or 30 VDC. See the Field Wiring as shown in **Figure 33**.

In a cascade system with an alarm condition at one or more units, alarm contacts of the rest of the units within the cascade can be energized indicating a fault condition. This feature can be enabled or disabled, refer to VERSA IC® Manual (241493) for further details on "Cascade Alarm".

Venting - General

▲ CAUTION: Proper installation of flue venting is critical for the safe and efficient operation of the boiler.

NOTE: Raypak strongly recommends installing the vent system before water piping. This will ensure that the venting system and associated components will fit into the allotted space for proper operation.

Appliance Categories

Heaters are divided into four categories based on the pressure produced in the exhaust and the likelihood of condensate production in the vent.

Category I – A heater which operates with a non-positive vent static pressure and with a vent gas temperature that avoids excessive condensate production in the vent.

Category II – A heater which operates with a non-positive vent static pressure and with a vent gas temperature that may cause excessive condensate production in the vent.

Category III – A heater which operates with a positive vent pressure and with a vent gas temperature that avoids excessive condensate production in the vent.

Category IV – A heater which operates with a positive vent pressure and with a vent gas temperature that may cause excessive condensate production in the vent.

See **Table M** for appliance category requirements.

NOTE: For additional information on appliance categorization, see appropriate ANSI Z21 Standard and the NFGC (U.S.), or B149 (Canada), or applicable provisions of local building codes.

▲ WARNING: Mixing of different manufacturers venting material is not permitted as this may create an unsafe condition.

CAUTION: Condensate drains for the vent piping are required for installations of the XVersL. Follow vent manufacturer instructions for installation and location of condensate drains in the vent. Condensate drain must use a trap and the trap must be primed with water to prevent flue gas leakage and must be routed to an appropriate container for treatment before disposal, as required by local codes.

▲ WARNING: Contact the manufacturer of the vent material if there is any question about the appliance categorization and suitability of a vent material for application on a Category IV vent system. Using improper venting materials can result in personal injury, death or property damage.

NOTE: Ensure that clearances are maintained per **Table D** and **Table E**.

Use only the special gas vent pipes listed for use with Category IV gas burning boilers as listed in **Table N** and **Table O**. Follow the vent manufacturer's installation instructions carefully.

In addition to the stainless steel vents listed in **Table O**, the XVersL product is also certified for use with PVC, CPVC, and Polypropylene vent products. See **Table N**, for information on Polypropylene venting.

Extractors, Draft Inducers, and Motorized Combustion Air Dampers

When extractors or inducers are used in the venting system, they must be interlocked with each connected appliance, to ensure proper operation. If individual motorized combustion air dampers are used, they must be interlocked to their respective appliance. See Field Wiring Connection section of this manual for proper wiring instructions, using Fan/Damper dry contacts and external interlock.

Support of Vent Stack

The weight of the vent stack or chimney must not rest on the boiler vent connection. Support must be provided in compliance with applicable codes. The vent should also be installed to maintain proper clearances from combustible materials.

Vent Terminal Location

NOTE: During winter months check the vent cap and make sure no blockage occurs from build-up of snow or ice.

1. Condensate can freeze on the vent cap. Frozen condensate on the vent cap can result in a blocked flue condition.
2. Give special attention to the location of the vent termination to avoid possibility of property damage or personal injury.
3. Gases may form a white vapor plume in winter. The plume could obstruct a window view if the termination is installed near windows.
4. Prevailing winds, in combination with below-freezing temperatures, can cause freezing of condensate and water/ice build-up on buildings, plants or roofs.
5. The bottom of the vent terminal and the air intake shall be located at least 12" (305 mm) above grade, including normal snow line.
6. Un-insulated single-wall Category IV metal vent pipe shall not be used outdoors in cold climates for venting gas-fired equipment without insulation.

Certified Materials	Exhaust Configuration	Heater Venting Category	Combustion Air Supply	Combustion Air Inlet Material
PVC, CPVC, Polypropylene and Stainless Steel UL listed ANSI/ASTM D1785 Sch 40 PVC, ANSI ASTM F441 Sch 40 CPVC	Vertical Venting	IV	From Inside Building (Non-Direct Venting)	Galvanized Steel PVC ABS CPVC
	Horizontal Through-the-Wall Venting			
	Vertical Venting		From Outside Building (Direct Venting)	
	Horizontal Through-the-Wall Venting			

Table M. Venting Category Requirements

Centrotherm - InnoFlue						
Model No.	Vent Size	Air Intake Terminal	Vent Terminal	Vent Pipe	Vent Pipe with Test Port	Vent Adapter
406L	4	ISELL0487	ISTT0420	4" InnoFlue Vent (ISVL046x) x = 1, 2, 3, 6, 10 ft	4" Test port InnoFlue Vent (ISTP04)	ISAAL0404
506L						
606L						
726L	6	ISEL0687	ISTT0620	6" InnoFlue Vent (ISVL06X) x = 1, 2, 3, 6, 10 ft	6" Test port InnoFlue Vent (ISTP06)	ISAAL0606
856L						
M&G DuraVent - "PolyPro"						
Model No.	Vent Size	Air Intake Terminal	Vent Terminal	Vent Pipe	Vent Pipe with Test Port	Vent Adapter
406L	4	90 Elbow	4PPS-TTBL	4" PolyPro (4PPS-xL), x = 12, 36, 72 in	4PPS-TPL	4PPS-04PVCM-4PPF
506L						
606L						
726L	6	90 Elbow	6PPS-TTBL	6" PolyPro (6PPS-xL), x = 12, 36, 72 in	6PPS-TPL	6PPS-06PVCM-6PPF
856L						
Z Flex - "Z Vent"						
Model No.	Vent Size	Air Intake Terminal	Vent Terminal	Vent Pipe	Vent Pipe with Test Port	Vent Adapter
406L	4	90 Elbow	2ZDTT4	4" Z Vent (2ZDP4x), x = 12, 24, 36, 72 in	2ZDTP4	2ZDCPVCG4
506L						
606L						
726L	6	90 Elbow	2ZDTT6	6" Z Vent (2ZDP6x), x = 12, 24, 36, 72 in	2ZDTP6	2ZDCPVCG6
856L						

Table N. Certified Polypropylene Horizontal Vent Termination and Adapter - Category IV

M&G Duravent - "Fas-N-Seal"						
Model No.	Vent Size	Air Intake Terminal	Vent Terminal	Vent Pipe	Vent Pipe with Test Port	Vent Adapter
406L	4	90 Elbow	FSTT4 or Raypak D15 (4")	4" Fas-N-Seal (FSVLx04) x = 6, 12, 18, 24, 36 in	FSTP04	FSA-4PVC-4FNS
506L						
606L						
726L	6	90 Elbow	FSTT6 or Raypak D15 (6")	6" Fas-N-Seal (FSVL3606) x = 6, 12, 18, 24, 36 in	FSTP06	FSA-6PVC-6FNS
856L						
Heat Fab - Saf-T Vent EZ Seal						
Model No.	Vent Size	Air Intake Terminal	Vent Terminal	Vent Pipe	Vent Pipe with Test Port	Vent Adapter
406L	4	90 Elbow	9414TERM or Raypak D15 (4")	4" Saf-T-Vent (9402), (9405), (9408)	9401PRB	9401PVC
506L						
606L						
726L	6	90 Elbow	9614TERM or Raypak D15 (6")	6" Saf-T-Vent (9602-316), (9605-316), (9608-316)	9601PRB	9601PVC
856L						
Z Flex - "Z Vent"						
Model No.	Vent Size	Air Intake Terminal	Vent Terminal	Vent Pipe	Vent Pipe with Test Port	Vent Adapter
406L	4	90 Elbow	2SVSTB04 or Raypak D15 (4")	4" Z Vent (2SVEPWCF0x) x = 4.5 in, 1, 1.5, 2, 3, 4, 5, 8, 10 ft	2SVSPRTO4.5	2SVSTTAO4.5
506L						
606L						
726L	6	90 Elbow	2SVSRTX06 or Raypak D15 (6")	6" Z Vent (2SVEP0x) x = 6.5 in, 1, 1.5, 2, 3, 4 ft	2SVSPRTO6.5	2SVSTTAO6
856L						

Table O. Certified Stainless Steel Horizontal Vent Termination and Adapters - Category IV

7. Through-the-wall vents for Category IV appliances shall not terminate over public walkways or over an area where condensate or vapor could create a nuisance or hazard or could be detrimental to the operation of regulators, relief valves, or other equipment.
8. Locate and guard vent termination to prevent accidental contact by people or pets.
9. DO NOT terminate vent in window well, stairwell, alcove, courtyard or other recessed area.
10. DO NOT terminate above any door, window, or gravity air intake. Condensate can freeze, causing ice formations.
11. Locate or guard vent to prevent condensate from damaging exterior finishes. Use a rust-resistant sheet metal backing plate against brick or masonry surfaces.
12. DO NOT extend exposed vent pipe outside of building beyond the minimum distance required for the vent termination. Condensate could freeze and block vent pipe.

U.S. Installations

Refer to the latest edition of the National Fuel Gas Code.

Vent termination requirements are as follows:

1. Vent must terminate at least 4' (1.2 m) below or 4' (1.2 m) horizontally from, window or gravity air inlet to the building.
2. The vent must not terminate above public walkways due to slip hazard from frozen condensate.
3. Terminate vent at least 3' (915 mm) above any forced air inlet located within 10' (3 m).
4. Vent must terminate at least 4' (1.2 m) horizontally, and in no case above or below unless 4' (1.2 m) horizontal distance is maintained, from electric meters, gas meters, regulators, and relief equipment.
5. Terminate vent at least 6' (1.8 m) away from adjacent walls.
6. DO NOT terminate vent closer than 5' (1.5 m) below roof overhang.

7. The vent terminal requires a 12" (305 mm) vent terminal clearance from the wall.
8. Terminate vent at least 12" (305 mm) above grade, including normal snow line.
9. Multiple direct-vent installations require a 4' (1.2 m) clearance between the ends of vent caps located on the same horizontal plane.

⚠ WARNING: The Commonwealth of Massachusetts requires that sidewall vented boilers, installed in every dwelling, building or structure used in whole or in part for residential purposes, be installed using special provisions as outlined on 74 of this manual.

Canadian Installations

Refer to latest edition of the B149 Installation Code.

A vent shall not terminate:

1. Directly above a paved sidewalk or driveway.
2. Within 6' (1.8 m) of a mechanical air supply inlet to any building.
3. Above a meter/regulator assembly within 3' (915 mm) horizontally of the vertical center-line of the regulator.
4. Within 6' (1.8 m) of any gas service regulator vent outlet.
5. Less than 1' (305 mm) above grade level.
6. Within 3' (915 mm) of a window or door which can be opened in any building, any non-mechanical air supply inlet to any building or the combustion air inlet of any other appliance.
7. Underneath a veranda, porch or deck, unless the veranda, porch or deck is fully open on a minimum of two sides beneath the floor, and the distance between the top of the vent termination and the underside of the veranda, porch or deck is greater than 1' (305 mm).

Venting Installation Tips

Support piping (See vent manufacturer's instructions):

- horizontal runs—at least every 5' (1.5 m)
- vertical runs—use braces at least every 10' (3 m)
- under or near elbows

⚠ WARNING: Examine the venting system at least once a year. Check all joints and vent pipe connections for tightness, corrosion or deterioration.

Venting Configurations

For boilers connected to gas vents or chimneys, vent installations shall be in accordance with the NFGC (U.S.), or B149 (Canada), or applicable provisions of local building codes.

⚠ CAUTION: This venting system may require the installation of supplemental condensate drains in the vent piping per the vent manufacturer's instructions. Failure to install these condensate drains in the venting system may cause a non-warrantable failure.

Vertical Venting (Category IV) - Stainless Steel and Polypropylene Installation

The maximum and minimum venting length for this boiler is shown in **Table P**.

The following information is related to stainless steel and Polypropylene venting materials. See **Table N** and **Table O** for appropriate adapters.

Any horizontal sections of a vent must have an upward slope of not less than 1/4" per linear foot from the boiler to the vent terminal. The horizontal portions of the vent shall also be supported for the design and weight of the material employed to maintain clearances and to prevent physical damage or separation of joints.

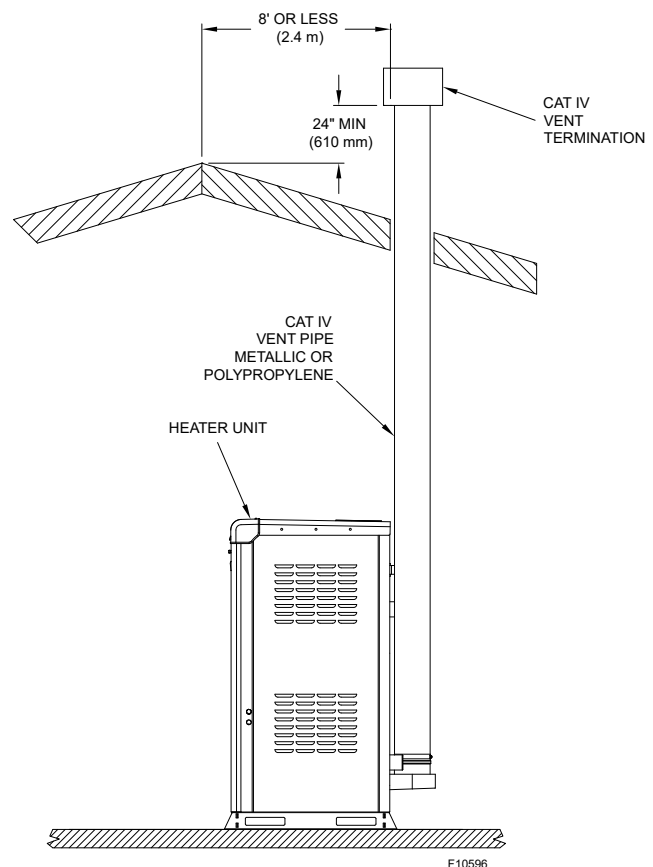

Figure 38. Vertical Venting for Stainless Steel and Polypropylene

Model No.	Certified Vent Material*	Vent Size in. (mm)	Total Vent Length (eq. ft.)** (m)		Combustion Air Intake Pipe Material	Air Inlet Max Length** (eq. ft.) (m)	
			Min.	Max.		4" Ø	6" Ø
406L	SS Cat IV (UL Listed), Polypropylene, PVC/CPVC	4 (100)	5 (1.5)	100 (30)	Galvanized Steel, PVC, CPVC, ABS	100 (30)	
506L							
606L	ANSI/ASTM D1785 Sch 40 PVC, ANSI ASTM F441 Sch 40 CPVC	6 (150)	5 (1.5)	100 (30)			
726L						100 (30)	
856L						100 (30)	

* Special vent materials are still required.

** Subtract 10 ft (3 m) per elbow. Max. 4 elbows.

Table P. Category IV Vertical and Horizontal Venting

Termination

The vent terminal must be vertical and must terminate outside the building at least 2' (0.6 m) above the highest point of the roof that is within 8' (2.4 m). The vent cap must have a minimum clearance of 4' (1.2 m) horizontally from and in no case above or below (unless a 4' [1.2 m] horizontal distance is maintained) electric meters, gas meters, regulators and relief equipment. See **Figure 38**.

The distance of the vent terminal from adjacent buildings, open windows and building openings must comply with the NFGC (U.S.) or B149 (Canada). Gas vents supported only by flashing and extended above the roof more than 5' (1.5 m) should be securely guyed or braced to withstand snow and wind loads.

CAUTION: A listed vent cap terminal suitable for connection to the Cat IV vent materials in **Table N** and **Table O**, adequately sized, must be used to evacuate the flue products from the building.

WARNING: Vent connectors serving any other appliances shall not be connected into any portion of mechanical draft systems operating under a positive pressure. If an XVersL boiler is installed to replace an existing boiler, the vent system **MUST** be verified to be of the correct size and of Category IV UL Listed stainless steel vent material construction or other approved vent materials noted in **Table M**. If it is **NOT**, it **MUST** be replaced.

NOTE: For extractor sizing, typical CO₂ levels are 9.0% for natural gas and 10.3% for propane gas and flue temperature of 150°F (65°C), at 100% firing rate, 40°F ΔT and return temperature of 120°F (49°C) measured at the test port, near the flue collar.

Model No.	Vent Size in. (mm)	Vent Pressure (in. WC)	Volume of Flue Products (CFM)
406L	4 (100)	0 to 0.2	120
506L			150
606L			180
726L	220		
856L	6 (150)		260

* NOTE: Data for 100% firing rate with range between min/max vent length.

Table Q. Typical Vent Pressure and Volume of Flue Products

Direct Vent-Vertical - Stainless Steel and Polypropylene Installation

These installations utilize the boiler-mounted blower to draw combustion air from outdoors and vent combustion products to the outdoors. To meet direct vent requirements, the combustion air ducting must be sealed.

The total length of air supply pipe cannot exceed the distances listed in **Table P**. Each elbow used is equal to 10' (3 m) of straight pipe. This will allow installation in any arrangement that does not exceed the lengths shown in **Table P**.

The vent cap is not considered in the overall length of the venting system. See **Table N** and **Table O** for appropriate adapters.

CAUTION: This venting system may require the installation of condensate drains in the vent piping per the vent manufacturer's instructions. Failure to install these condensate drains in the venting system may cause a non-warrantable failure.

Care must be taken during assembly that all joints are sealed properly and are airtight.

The vent must be installed to prevent the potential accumulation of condensate in the vent pipes. It is required that:

1. The vent must be installed with a condensate drain located in proximity to the boiler as directed by the vent manufacturer.
2. The vent must be installed with a slight upward slope of at least 1/4" per foot of horizontal run to the vent terminal.

Termination

The vent cap MUST be mounted on the exterior of the building. The vent cap cannot be installed in a well or below grade. The vent cap must be installed at least 12" (305 mm) above ground level and above normal snow levels.

The vent cap MUST NOT be installed with any combustion air inlet directly above a vent cap. This vertical spacing would allow the flue products from the vent cap to be pulled into the combustion air intake installed above.

This type of installation can cause non-warrantable problems with components and poor operation of the boiler due to the recirculation of flue products. Multiple vent caps installed in the same horizontal plane must have at least 4" (100 mm) clearance from the side of one vent cap to the side of the adjacent vent cap(s).

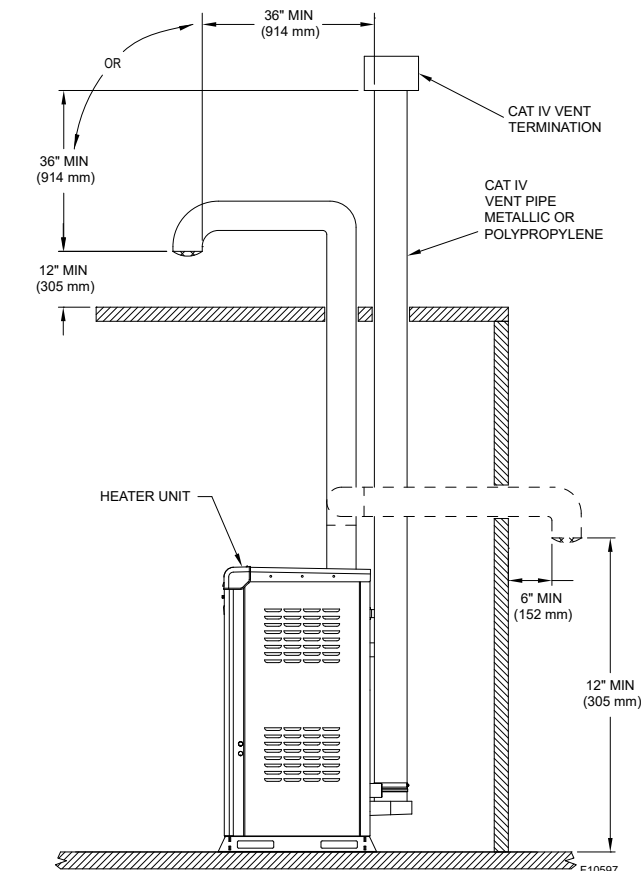

Figure 39. Direct Vent-Vertical for Stainless Steel and Polypropylene

NOTE: While a condensate drain connection for the vent system is required on all XVersL installations, the drain can be accomplished in several different ways. The figures in this section show the drain from the heat exchanger, however, this can also be accomplished using an additional inline collector for condensing stacks or an additional inline vertical or horizontal collector available from several of the listed vent manufacturers.

Combustion air supplied from outdoors must be free of particulate and chemical contaminants. To avoid a blocked flue condition, keep the vent cap clear of snow, ice, leaves, debris, etc.

The approved flue direct vent cap must be installed in accordance with its listing. See **Table N** and **Table O**.

⚠ WARNING: Mixing of different manufacturers venting material is not permitted as this may create an unsafe condition.

Horizontal Through-the-Wall and Direct Vent - Horizontal - Stainless Steel and Polypropylene

The XVersL boilers may be vented horizontally (either using room air for combustion or ducted air for combustion) as shown in the following figures. The air intake terminal may be located in a different pressure zone (i.e. on different walls) from the vent termination. See **Figure 40** and **Figure 41**.

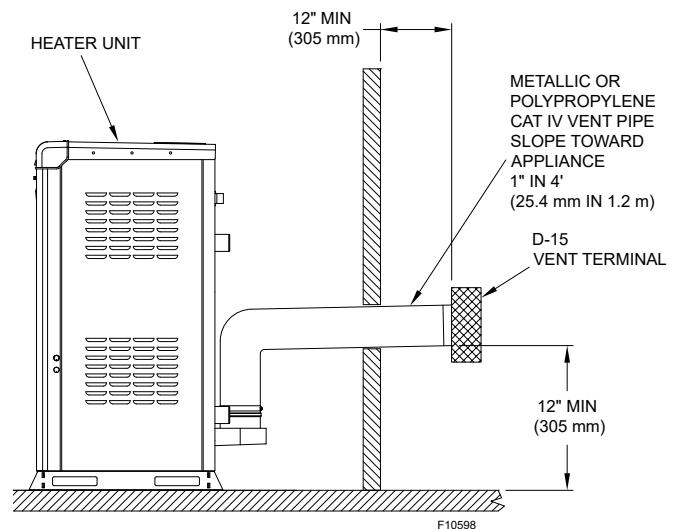

Figure 40. Horizontal Through-the-Wall Venting for Stainless Steel and Polypropylene

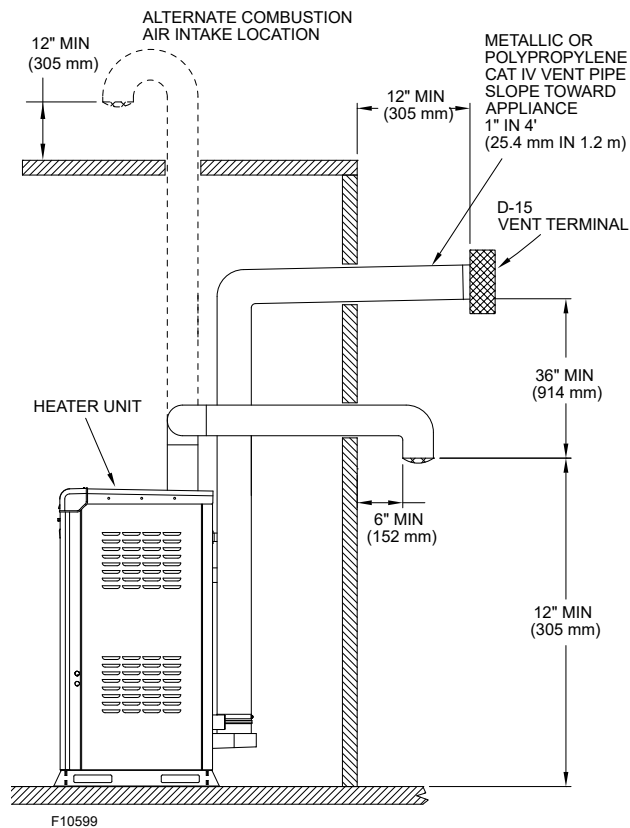

Figure 41. Direct Vent-Horizontal for Stainless Steel and Polypropylene

CAUTION: This venting system may require the installation of supplemental condensate drains in the vent piping per the vent manufacturer's instructions. Failure to install these condensate drains in the venting system may cause a non-warrantable failure.

Installation

These installations utilize the boiler-mounted blower to vent the combustion products to the outdoors. Combustion air is taken from inside the room or directly from outdoors and the vent is installed horizontally through the wall to the outdoors. Adequate combustion and ventilation air must be supplied to the equipment room in accordance with the NFGC (U.S.) or B149 (Canada). The vent termination placement may interfere with the placement of the combustion air intake, see **Figure 42**. To meet direct vent requirements, the combustion air ducting must be sealed.

The total length of the horizontal through-the-wall flue system should not exceed the maximum equivalent ft in length. See **Table P** for maximum length. If horizontal run exceeds the maximum equivalent ft, an appropriately sized variable-speed extractor must be used. Each elbow used is equal to 10' (3 m) of straight pipe. This will allow installation in one of the four following arrangements (example shown for Model 856L with 6" vent):

- 100 ft (30 m) of straight flue pipe
- 90 ft (27 m) of straight flue pipe and one elbow

- 80 ft (24 m) of straight flue pipe and two elbows
- 70 ft (21 m) of straight pipe and three elbows

The vent cap is not considered in the overall length of the venting system.

The vent must be installed to prevent flue gas leakage. Care must be taken during assembly to ensure that all joints are sealed properly and are airtight. The vent must be installed to prevent the potential accumulation of condensate in the vent pipes. It is required that:

1. The vent must be installed with a condensate drain located in proximity to the boiler as directed by the vent manufacturer.
2. The vent must be installed with a slight upward slope of not less than 1/4" per foot of horizontal run to the vent terminal.

Termination

The sidewall vent termination **MUST** be mounted on the exterior of the building. The vent termination cannot be installed in a well or below grade. The vent termination must be installed at least 12" (305 mm) above ground level and at least 12" (305 mm) above normal snow levels. The Raypak approved horizontal, stainless steel flue vent termination must be used (see **Table N** and **Table O**). The vent termination must be located **NO CLOSER** than 12" (305 mm) off the wall.

WARNING: Mixing of different manufacturers venting material is not permitted as this may create an unsafe condition.

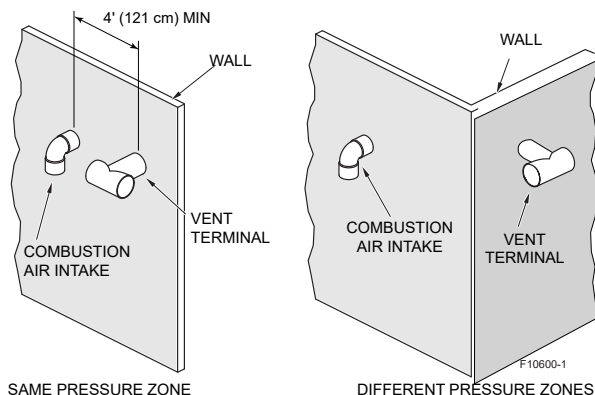

Figure 42. Air Intake Location

Vertical Venting (Category IV) - PVC/CPVC

Installation

The maximum and minimum venting length for this boiler is shown in **Table P**.

The following information is related to PVC and CPVC venting materials. PVC/CPVC venting requires the vent to be offset from the flue connection of the boiler as shown in **Figure 45**. The vent must be offset (field-supplied) to

prevent chlorides from the vent material draining back into the boiler drain pan, causing a non-warrantable failure of the heat exchanger.

NOTE: Use only certified vent material ANSI/ASTM D1785 Sch 40 PVC, ANSI ASTM F441 Sch 40 CPVC.

Any horizontal sections of a vent must have an upward slope of at least 1/4" per linear foot from the boiler to the vent terminal. The horizontal portions of the vent shall also be supported for the design and weight of the material employed to maintain clearances and to prevent physical damage or separation of joints. A condensate trap and drain are required at the bottom of the PVC/CPVC tee as shown in **Figure 43**.

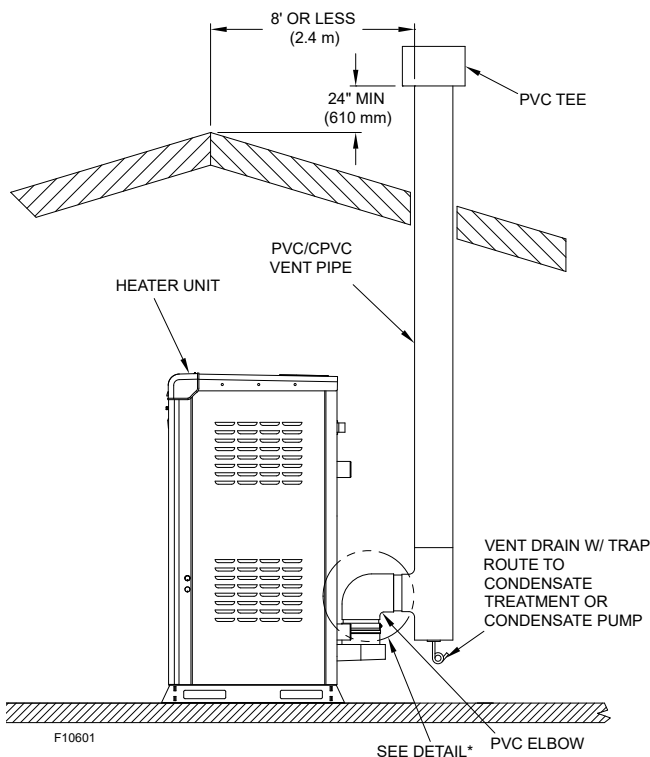

* See "Figure 46. PVC Assembly Detail - Field Installed" on page 40

Figure 43. Vertical Venting for PVC/CPVC

Termination

The vent cap must be vertical and must terminate outside the building at least 2' (0.6 m) above the highest point of the roof that is within 8' (2.4 m). The vent cap should have a minimum clearance of 4' (1.2 m) horizontally from and in no case above or below (unless a 4' [1.2 m] horizontal distance is maintained) electric meters, gas meters, regulators and relief equipment.

The distance of the vent terminal from adjacent buildings, open windows and building openings must comply with the NFGC (U.S.) or B149 (Canada). Gas vents supported only by flashing and extended above the roof more than 5' (1.5 m) should be securely guyed or braced to withstand snow and wind loads.

CAUTION: A vent cap tee, suitable for connection to the Cat IV PVC/CPVC vent materials, must be used to evacuate the flue products from the building.

WARNING: Vent connectors serving any other appliances shall not be connected into any portion of mechanical draft systems operating under a positive pressure. If an XVersL boiler is installed to replace an existing boiler, the vent system **MUST** be verified to be of the correct size and of Category IV vent material construction or other approved vent materials. If it is **NOT**, it **MUST** be replaced.

NOTE: For extractor sizing, typical CO₂ levels are 9.0% for natural gas and 10.3% for propane gas and flue temperature of 150°F (65°C), at 100% firing rate, 40°F ΔT and return temperature of 120°F (49°C) measured at the test port, near the flue collar.

WARNING: DO NOT insulate PVC/CPVC vent.

WARNING: DO NOT use foam core or cellular core PVC/CPVC for venting.

Direct Vent - Vertical - PVC/CPVC

NOTE: Use only certified vent material ANSI/ASTM D1785 Sch 40 PVC, ANSI ASTM F441 Sch 40 CPVC.

Installation

These installations utilize the boiler-mounted blower to draw combustion air from outdoors and vent combustion products to the outdoors. The total length of air supply pipe cannot exceed the distances listed in **Table P**. Each elbow used is equal to 10' (3 m) of straight pipe. This will allow installation in any arrangement that does not exceed the lengths shown in **Table P**. To meet direct vent requirements, the combustion air ducting must be sealed.

PVC/CPVC venting requires the vent to be offset (field-supplied) from the flue connection of the boiler as shown in **Figure 43-47**, including the detail in **Figure 46**. The vent must be offset to prevent chlorides from the vent material draining back into the boiler drain pan causing a non-warrantable failure of the heat exchanger.

The height of the offset must allow adequate height for the condensate to drain from the vent tee.

The vent cap is not considered in the overall length of the venting system.

CAUTION: This venting system requires the installation of condensate drains in the vent piping per the vent as shown in **Figure 44**. Failure to install these condensate drains in the venting system may cause a non-warrantable failure.

Care must be taken during assembly that all joints are sealed properly and are airtight.

The vent must be installed to prevent the potential accumulation of condensate in the vent pipes. It is required that:

1. The vent must be installed with a condensate drain located in proximity to the boiler as directed by the vent manufacturer.
2. The vent must be installed with a slight upward slope of at least 1/4" per foot of horizontal run to the vent terminal.

Termination

The vent cap **MUST** be mounted on the exterior of the building. The vent cap cannot be installed in a well or below grade. The vent cap must be installed at least 1' (305 mm) above ground level and at least 1' (305 mm) above normal snow levels.

The vent cap **MUST NOT** be installed with any combustion air inlet directly above a vent cap. This vertical spacing would allow the flue products from the vent cap to be pulled into the combustion air intake installed above. This type of installation can cause non-warrantable problems with components and poor operation of the boiler due to the recirculation of flue products.

Multiple vent caps installed in the same horizontal plane must have a 4' (1.2 m) clearance from the side of one vent cap to the side of the adjacent vent cap(s). Combustion air supplied from outdoors must be free of particulate and chemical contaminants. To avoid a blocked flue condition, keep the vent cap clear of snow, ice, leaves, debris, etc.

The approved vent cap for PVC/CPVC is a tee and it must be installed in accordance with **Figure 44** and **Figure 45**.

⚠ WARNING: Mixing of PVC and CPVC venting materials is not permitted as this may create an unsafe condition.

Horizontal Through-the-Wall and Direct Vent - Horizontal - PVC/CPVC

NOTE: Use only certified vent material ANSI/ASTM D1785 Sch 40 PVC, ANSI ASTM F441 Sch 40 CPVC.

The XVersL boilers may be vented horizontally (either using room air for combustion or ducted air for combustion) as shown in the following figures. The air intake terminal may be located in a different pressure zone (i.e. on different walls) from the venting termination. See **Figure 44**.

⚠ CAUTION: This venting system requires the installation of condensate drains in the vent piping as shown in Figure 45 or Figure 47. Failure to install these condensate drains in the venting system may cause a non-warrantable failure.

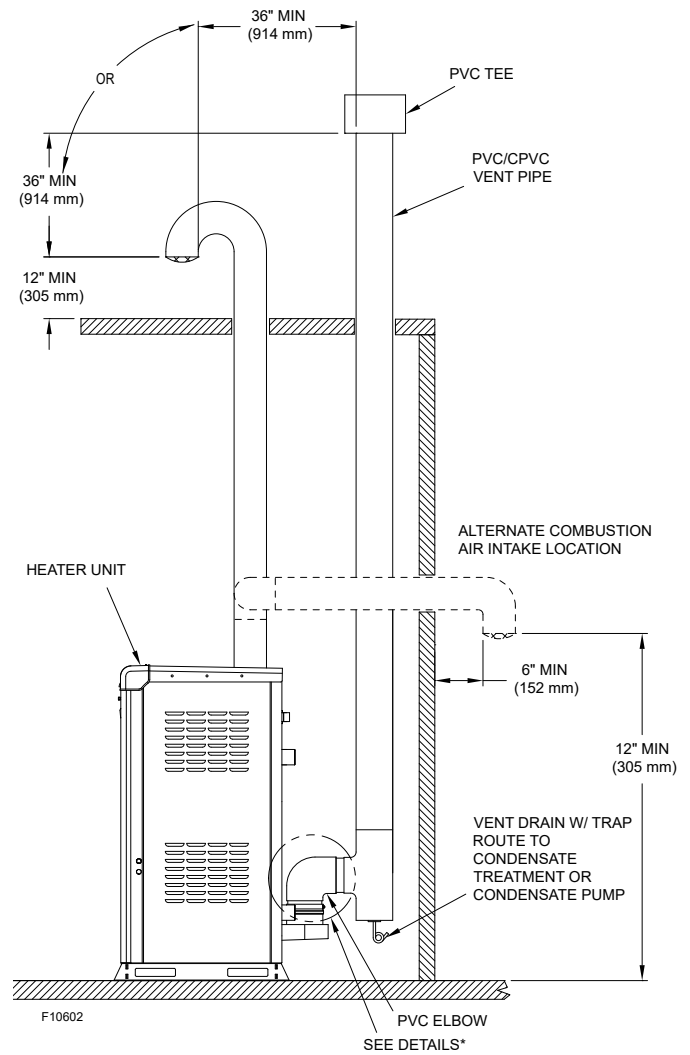

* See "Figure 46. PVC Assembly Detail - Field Installed" on page 40

Figure 44. Direct Vent-Vertical for PVC/CPVC

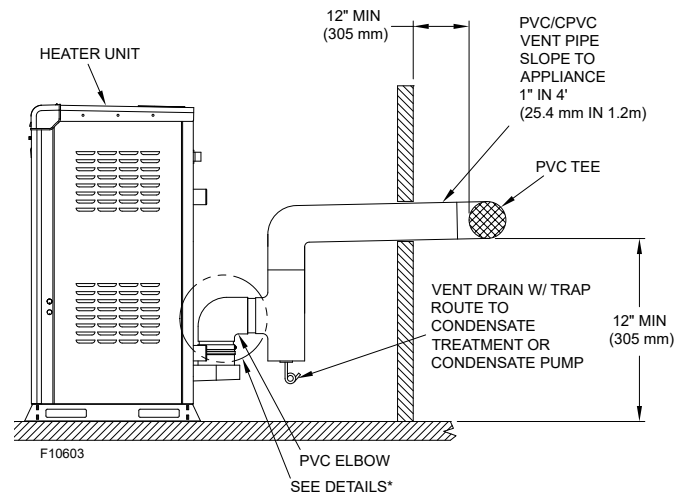

* See "Figure 46. PVC Assembly Detail - Field Installed" on page 40

Figure 45. Horizontal Through-the-Wall Venting for PVC/CPVC

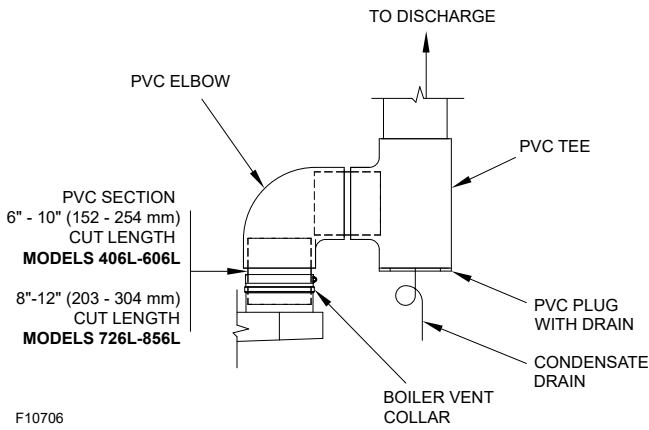
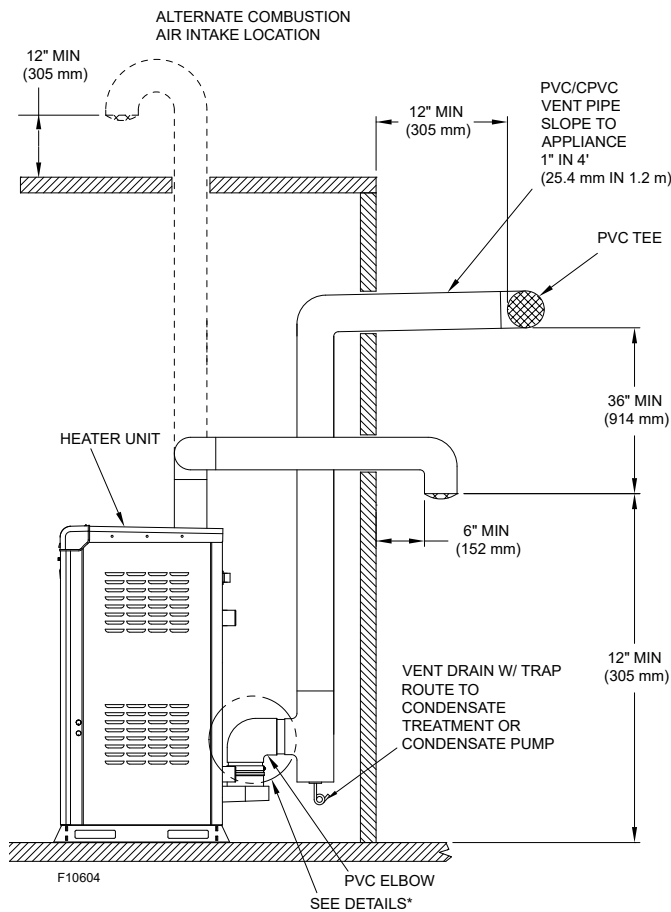

Figure 46. PVC Assembly Detail - Field Installed



* See "Figure 46. PVC Assembly Detail - Field Installed" on page 40

Figure 47. Direct Vent-Horizontal for PVC/CPVC

Installation

These installations utilize the boiler-mounted blower to vent the combustion products to the outdoors. For direct-vent installations, the blower also draws combustion air through a sealed intake duct from elsewhere. Otherwise, combustion air is taken from inside the room. Adequate

ventilation air (and combustion air, if into direct-venting) must be **supplied** to the equipment room in accordance with the NFGC (U.S.) or B149 (Canada).

PVC/CPVC venting requires the vent to be offset (field-supplied) from the flue connection of the boiler as in **Figure 45** and **Figure 47**. The vent must be offset to prevent chlorides from the vent material draining back into the boiler drain pan causing a non-warrantable failure of the heat exchanger.

A condensate trap and drain are required at the bottom of the PVC/ CPVC tee as shown in **Figure 45** and **Figure 47**. The total length of the horizontal through-the-wall flue system should not exceed the maximum equivalent ft in length. See **Table P** for maximum length. If horizontal run exceeds the maximum equivalent ft, an appropriately-sized variable-speed extractor must be used. Each elbow used is equal to 10' (3 m) of straight pipe. This will allow installation in one of the four following arrangements (example shown for Model 856L with 6" vent):

- 100 ft. (30 m) of straight flue pipe
- 90 ft. (27 m) of straight flue pipe and one elbow
- 80 ft. (24 m) of straight flue pipe and two elbows
- 70 ft. (21 m) of straight flue pipe and three elbows

The vent termination is not considered in the overall length of the venting system. The vent must be installed to prevent flue gas leakage. Care must be taken during assembly to ensure that all joints are sealed properly and are airtight. The vent must be installed to prevent the potential accumulation of condensate in the vent pipes. It is required that:

- The vent must be installed with a condensate drain located in proximity to the boiler as directed by the vent manufacturer.
- The vent must be installed with a slight upward slope of not less than 1/4" per foot of horizontal run to the vent terminal.

Termination

The vent termination **MUST** be mounted on the exterior of the building. The vent termination cannot be installed in a well or below grade. The vent termination must be installed at least 12" (305 mm) above ground level and at least 12" (305 mm) above normal snow levels. The approved horizontal, PVC/CPVC vent termination is a Tee of the same size as the vent pipe. See **Figure 45** and **Figure 47**. The vent terminal must be located **NO CLOSER** than 12" (305 mm) off the wall.

Outdoor Installation

Boilers must not be installed outdoors in freezing climates. Boilers installed outdoors must be vented with listed UV-resistant vent material per the following instructions and installed with the factory-supplied Outdoor Vent Kit sales option D-11. See **Table R**. A special vent cap is provided in accordance with CSA requirements. This must be installed directly on the vent pipe as illustrated in **Figure 48**.

Model No.	Outdoor Kit No.
406L-606L	017730
726L-856L	016729

Table R. Outdoor Vent Kits

NOTE: External support of outdoor venting is required if the vent extends beyond the jacket top by more than 36" (914 mm).

The flue outlet is not designed to support the weight of the vent system beyond 36" (914 mm) above the jacket top. Supplemental support is required if the vent extend beyond 36" (914 mm).

The Raypak Outdoor Vent Kits contain the following components:

- PVC to Polypropylene Adapter
- 40" Vent Sections
- Vent Termination Tee
- Installation Instructions

Care must be taken when locating the boiler outdoors, because the flue gases discharged from the vent cap can condense as they leave the cap. Improper location can result in damage to adjacent structures or building finish.

For maximum efficiency and safety, the following precautions must be observed:

1. When boilers are installed outdoors, they must use the Outdoor Vent Kit that is available from the manufacturer (See **Table R** or sales order option D-11). Follow instructions provided with kit for installation.
2. Periodically check venting system. The boiler's venting areas must never be obstructed in any way and minimum clearances must be observed to prevent restriction of combustion and ventilation air. See **Table E**. Keep area clear and free of combustible and flammable materials.
3. Do not locate adjacent to any window, door, walkway, or gravity air intake. The vent must be located a minimum of 4' (1.2 m) horizontally from such areas.

NOTE: Condensate can freeze on the vent cap. Frozen condensate on the vent cap can result in a blocked flue condition.

4. Install above grade level.
5. Vent terminal must be at least 3' (914 mm) above any forced air inlet located within 10' (3 m).
6. Adjacent brick or masonry surfaces should be protected with a rust-resistant sheet metal plate to prevent staining/corrosion of the wall surfaces.

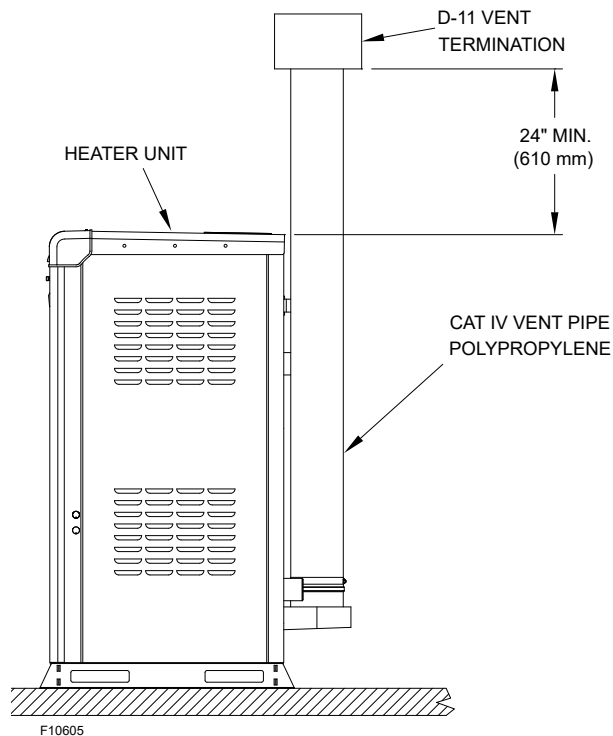

Figure 48. Outdoor Installation

Common Venting

The NFGC does not address sizing guidelines for the common venting of multiple Category IV boilers. This is covered in the NFGC under "Engineered Vent Systems". **Table Q** provides boiler discharge vent pressures at vent pressure switch and volumes of flue products at full fire for the calculation of appropriate vent and extractor sizing for common venting.

Raypak does not support common venting under positive-pressure conditions. Use an external variable-speed extractor to draw the stack to negative pressure. See **Figure 49**. Interlock the extractor to each connected boiler at terminals #17 and #18 (See **Figure 33**) to ensure that no connected boilers will fire until the extractor is proven operational.

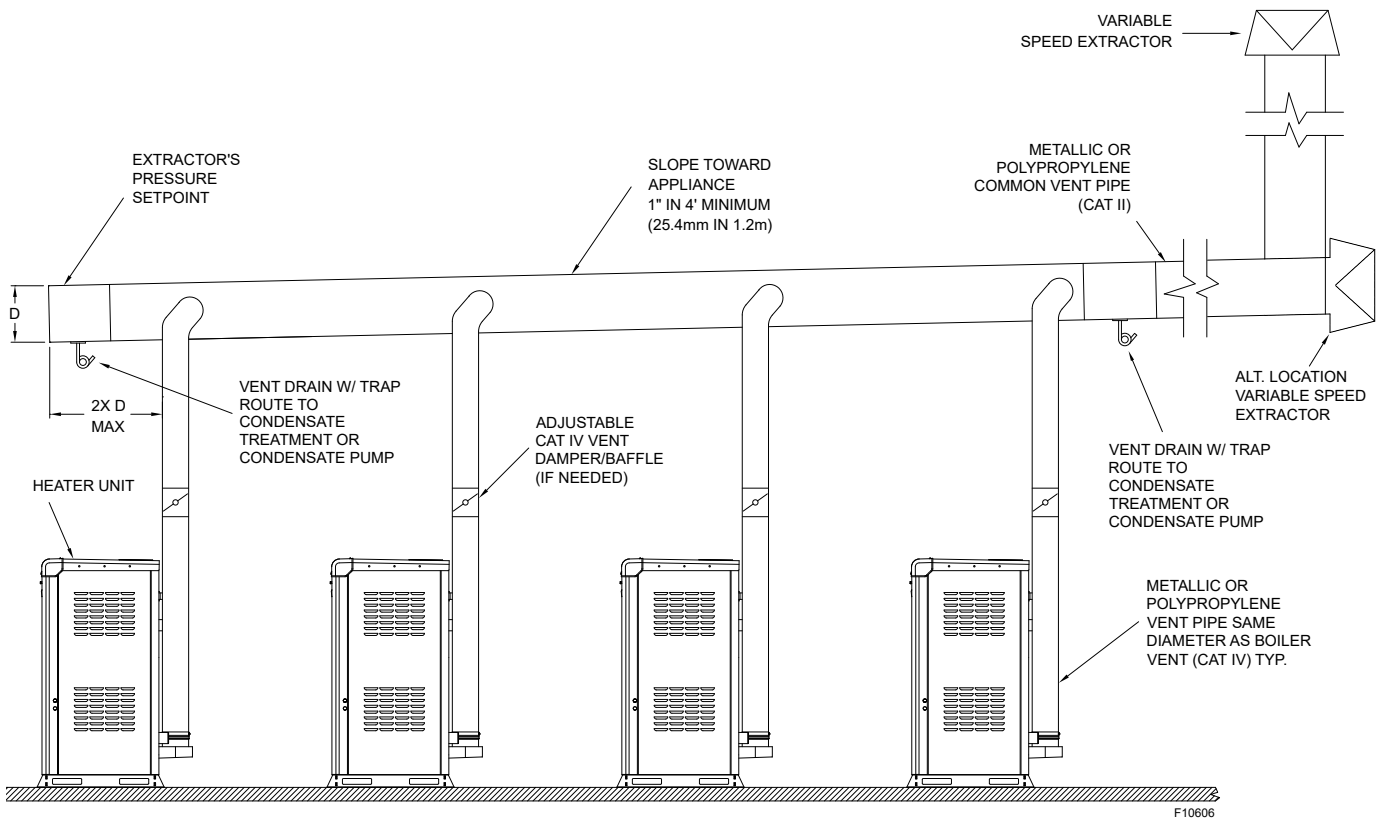

Figure 49. Typical Common Venting (Stainless Steel or Polypropylene)

Condensate Treatment

The condensate must be drained properly to protect the appliance and drainage system. The condensate from the boiler condensate drain is acidic. Its pH is typically between 3.2 and 4.5.

The factory-installed option of the Condensate Treatment Kit Z-12 is connected to the condensate drain of the boiler and contains treatment media to raise the pH level of the condensate.

The pH of the effluent entering a sanitary drain must be 5.0 or higher.

CAUTION: Condensate drain lines must not be allowed to freeze. Take appropriate measures.

WARNING: Do not install the heater outdoors if freezing conditions are typical. The condensate will freeze and back up the flue system.

CAUTION: In general, the condensate piping from the appliance must have a downward slope of 1/4" per horizontal foot. Condensate drain traps must be primed with water to prevent gas flue leaks. Treatment kits should be checked at least once per year. To ensure the pH of the effluent is 5.0 or higher, the media should be replenished as necessary. When replacing the media, they should be no smaller than 3/4" to avoid blockage in the condensate piping.

Vent pipe condensate drains are also required for installation of the XVersL when using PVC or CPVC. Follow instructions for location of condensate drains in the vent as noted in "Venting Configurations" on page 34 as appropriate.

CAUTION: In general, the condensate piping from the appliance must have a downward slope of 1/4" per horizontal foot. Condensate drain traps must be primed with water to prevent flue gas leaks. Condensate Treatment Kits should be checked at least once per year. To ensure the pH of the effluent is 5.0 or higher, the media should be replenished as necessary. Contact a Raypak representative.

Figure 50 is a visual guide only. Follow the manufacturer's instructions for the installation of the Condensate Treatment Kit and condensate drains.

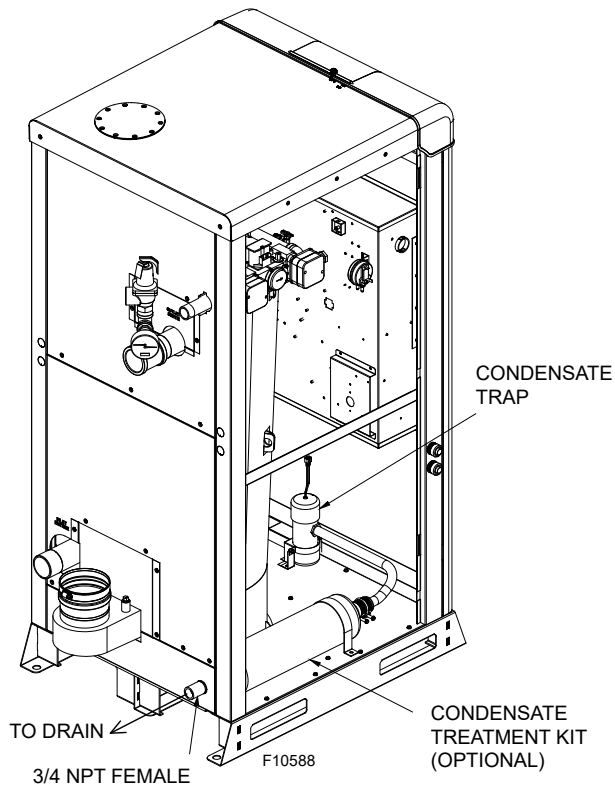

Figure 50. Visual Guide for Condensate Piping

Freeze Protection

To enable freeze protection, DIP switch position 7 (on the PIM) must be turned ON (UP position). This is the default position.

If the water temperature drops below 45°F (7°C) on the Outlet or Inlet sensors, the boiler pump/isolation valve is enabled. The boiler pump is turned off/isolation valve closed when both the Inlet and Outlet temperatures rise above 50°F (10°C).

If either the Outlet or Inlet temperature drops below 38°F (3°C), the VERSA starts the burner at the minimum firing rate. The burner cycle will terminate when both the Inlet and Outlet temperatures rise above 42°F (6°C).

NOTE: Failure of the optional flow meter, if present, will block a heating cycle even if temperatures drop below 38°F (3°C).

5. CONTROLS

Sequence of Operation

1. Upon initial application of 24VAC power, by toggling the rocker switch to the "IDLE" position the PIM resets with all outputs in the "OFF" state.
2. Enabling the unit by toggling the third position (RUN) of the rocker switch, allows the PIM and VERSA IC® to perform a processor and memory self-test to ensure proper operation.
3. The PIM confirms the presence of a valid ID card which matches the configuration stored in memory at the factory. If a valid ID card is NOT present, the PIM generates a diagnostic fault (ID Card Fault) and will shut down waiting for this fault to be addressed.
4. The PIM reads the DIP switch settings and configures itself for the desired operation. PIM DIP 3 = OFF indicates primary-only pipe configuration, which uses an Isolation valve, while PIM DIP 3 = ON means primary / secondary and uses a boiler pump.
5. The PIM scans the Ft_bus communications for the VERSA board and if found, system operation is controlled by the VERSA board. If the PIM does not find the VERSA board, it will enter "limp-along" mode. See Section 11 of the VERSA IC® Manual (241493).
6. Non-volatile memory is checked for any active lockout conditions. If any exist, they must be addressed before the PIM will allow a new trial for ignition to start.
7. The PIM continually monitors the flame status to ensure that no flame is present during standby. If an erroneous flame is detected, the PIM generates a False Flame error fault.
8. The PIM verifies that the vent sensor is below the vent limit temperature before burner operation. The control uses the input from this sensor to automatically reduce firing rate should the vent temperature approach the vent material temperature limits. If the vent temperature is exceeded, the PIM performs a Post-purge and proceeds to a hard lockout (manual-reset).
9. A call-for-heat is initiated by the presence of any one or more of the sources below. See **Figure 33**.
 - a. A heat demand (contact closure) on the Enable/Disable field wiring terminals (#11 and #12).
 - b. A voltage greater than 1.0 VDC on the analog 0-10 VDC EMS signal input (#13 and #14).
 - c. A heat demand present on the indirect DHW field wiring terminals (#4 and #5).
 - d. A heat demand from the VERSA board based on the DHW sensor temperature.

10. The PIM initiates a trial-for-ignition (TFI) counter to the programmed number of trials for ignition (1 or 3) and proceeds to Pump Purge mode.
11. The VERSA board will turn on the boiler pump and/or keep the Isolation Valve open, turn on the system, and/or DHW pump as necessary to address the call-for-heat. This is dependent on the Mode of operation selected and the PIM DIP #3 position. The boiler will proceed through its pre-purge period before the control will move into a Trial-for-Ignition.
21. The blower light-off RPM speed is verified.
22. The gas valve relay contacts are verified open – if closed, a fault code will be issued and the boiler will post-purge and go into a hard lockout condition.
23. The XVersL boilers are equipped with direct spark igniter (DSI):
 - a. The control turns on the DSI and the DSI proving current is verified to be above the threshold value (3.2A reference).
 - b. The configured heat-up delay takes place to allow the DSI element to reach ignition temperature.
 - c. The gas valve output is energized for the trial for-ignition time to light the burner.
 - d. The DSI is de-energized during the last second of the trial-for-ignition period to sense for the burner flame.
 - e. The flame sense is checked for successful lighting of the burner. If a valid flame is detected, the main gas valve, operating pumps and blower relay remain energized and the PIM proceeds to the Heating mode.

Steps 12 and 13 are applicable if optional flow meter is installed:

12. The PIM will only allow for ignition as long as the flow meter detects a flow higher than the minimum flow requirement for the unit. If minimum flow is not achieved within 90 seconds, the unit will broadcast a “Flow Error” condition and will hold from ignition until proper flow is observed.
 - a. An alarm will notify the user that the unit did not ignite due to insufficient flow.
 - b. If sufficient flow is present at the flow meter and can be verified by the user, it is assumed that the flow meter needs to be serviced. Under this situation the user can override the Flow Error and allow ignition and select an allowable firing rate up to 80%. NOTE: Flow Override will expire after 24 hours. Once time has expired, the unit will cycle and alarm will turn back on. If the unit cycles power within the 24-hour period, the Flow Override expiration time will be reset.
13. If the flow meter detects flow equal to or higher than the minimum flow requirement, then the unit is allowed to proceed to the trial for ignition.

14. The VERSA board and PIM check the safety circuit and will prevent a trial for ignition if any of the safety devices are in an error/fault condition.
15. The blower is energized and set to pre-purge speed.
16. Once the blower speed is acknowledged as operating at the pre-purge speed by the tachometer output, the blower proceeds to pre-purge for the specified duration.
17. The secondary voltage level of the 24VAC supply input is confirmed to be above 18VAC – if not, a Low Voltage fault will be recorded and the boiler will shut off until the voltage rises above 18VAC consistently.
18. If all checks have passed, the system proceeds to ignition.
19. The PIM re-initializes the ignition counter to the configured number of trials (1 or 3).
20. The Hi Limit sensor is confirmed to read below the Hi Limit setpoint.
24. If flame is not detected during the trial-for-ignition period, the gas valve output is disabled immediately and the blower goes to a post-purge.
25. On single trial-for-ignition models, the PIM enters ignition lockout and the LED on the PIM indicates the fault code for ignition lockout. The VERSA IC® Display should also state Ignition Lockout. To reestablish operation after the post purge has been completed and clear the lockout error, press the reset button.
26. On multi-trial-for-ignition models, the control goes through an inter-purge delay before additional ignition attempts are started. If no flame is detected after the final trial-for-ignition, the PIM enters ignition lockout and the LED on the PIM indicates the fault code for ignition lockout. The VERSA IC® Display should also state Ignition Lockout. To reestablish operation after the post purge has been completed and clear lockout error, press the reset button.
27. When the unit is firing, the firing rate of the unit is always governed by the amount of flow sensed through the heat exchanger, and Delta T. The less flow, the less maximum allowable firing rate. However the system will still modulate based on target and supply temperature, EMS signal or Modbus Rate modes between min firing rate and maximum allowable firing rate according with the water flow across the heat exchanger.

VERSA Integrated Control

The XVersL product family is equipped with a sophisticated set of software rules intended to protect the integrity of the equipment and at the same time guarantee the most efficient operational point of the boiler.

These software rules will prevent the boiler from cycling excessively, avoiding unnecessary stress on the combustion chamber elements. Additionally, the VERSA integrated control is able to anticipate required maintenance of internal parts, and diagnose common application problems that could lead to deterioration of the boiler, such as sudden loss of flow, overshoot of supply temperature, excessive temperature on flue pipe, and outlet water temperature spikes, among others.

Flow Meter F-15 (Optional)

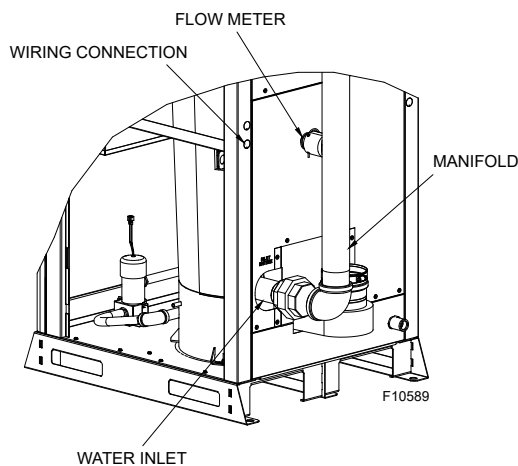

Figure 51. Flow Meter

The Flow sensor acts as a governor for the boiler, and depending on the flow reading, the control allows the boiler to operate up to a calculated maximum firing rate as a function of the flow rate observed. In spite of calculated maximum allowable firing rate of the unit, the system will still modulate to achieve target or obey an external rate command.

Flow Override (if optional flow meter is installed)

In the unlikely event that the optional flow meter reading is compromised, due to several possible external factors, the user is able to override the minimum flow requirement and permit ignition of the unit.

CAUTION: Sufficient water flow has to be confirmed before enabling the flow override function. Severe heat exchanger damage could occur if there is insufficient flow across the heat exchanger during operation.

The flow override setting will only become visible when the boiler is alarming due to an unsuccessful call for heat as a result of insufficient flow detection. The setting can be found under Adjust Setting within the System Settings section.

When the "Flow Override" is activated, the user is able to select the maximum firing rate at which the boiler can operate. The system will still modulate up to this maximum firing rate to achieve target. The maximum firing rate is defined by the user between minimum firing rate of the unit up to 80%. The Flow Override function has an expiration time of 24 hours, and must be manually reactivated for the unit to continue operation under such conditions.

Under Flow Error (if optional flow meter is installed)

"Under Flow Error" is only possible when the boiler is already firing. It is considered an Under Flow Error when the flow reading drops below the operational criteria for the boiler, or is totally lost during an active heat demand. In this scenario, the boiler will broadcast an error and alarm. However, it will not stop providing heat. Instead, the unit automatically reduces firing rate to minimum firing rate. If flow is indeed null or low, the boiler has other protection algorithms such as Outlet Max, and Max Delta T Protection, which will shut down the boiler if these values are exceeded.

Cascade Flow Offset (if optional flow meter is installed)

In a cascade configuration, the master XVersL boiler will only allow the next unit in the cascade to operate when the observed flow is double the minimum flow requirement of the next unit in the cascade. This is to overcome any pressure drop when enabling the second boiler. It is expected that the flow will drop significantly when the isolation valve of the next boiler in the cascade is opened. Because pressure drop may vary depending on several specific conditions of each job site, the Cascade Flow Offset provides the ability to fine tune the minimum flow requirement in a cascade configuration. Adjusting the Cascade Flow Offset will affect the call of the next unit in the cascade (speed up or delay the call). This setting is located within the Adjustment Menu in system settings. The default value is "0" with a range of -25 gpm to +15 gpm (-95 lpm to +57 lpm).

Example: If the cascade consists of 3 boilers where each boiler has a MIN flow condition of 40 gpm (151 lpm), and the Cascade Flow Offset value is "0" (factory default), the master boiler requires seeing a minimum 80 gpm (302 lpm) before attempting to open the second boiler isolation valve (upon a continued call for heat). Adjusting the Cascade Flow Offset value to "-5" results in the master boiler seeing a minimum flow equal to $[40 - 5 = 35 \text{ gpm} (132 \text{ lpm})]$ for each boiler or 70 gpm (264 lpm) total before attempting to open the second boiler isolation valve.

The following functions of the VERSA IC® are applicable only if an optional flow meter is installed.

ΔT Protection Zones

The ΔT Protection Zones are a function of the VERSA IC® which monitors flow, firing rate, and anticipated ΔT based on the type of fluid (water or water/glycol concentration) being heated to determine if the heater is functioning properly.

The XVersL product includes multiple checks to ensure the safe performance of the unit. If the flow meter reading is determined to be inaccurate, the unit will still find the optimum point of operation based on the ΔT. If heater flow is indeed below what is being reported by the sensor, the ΔT will increase in proportion to the flow discrepancy.

The XVersL will adjust firing rates using dynamic thresholds called “ΔT zones”. These zones are (1) Flow Warning Zone, (2) Hold Firing Rate Zone, and (3) Min Firing Rate Zone, described in the following sections.

Flow Warning Zone

The Flow Warning Zone is considered a warning. The service light will flash, no alarm will be triggered, and a warning error will be broadcast and recorded. The flow warning indicates that the ΔT is higher than the expected value given a specific flow and firing rate.

The Flow Warning Zone operates in conjunction with the user-defined ΔT Offset – see Troubleshooting, **Section 9** for more details. If the ΔT continues to increase and exceeds the Flow Warning Zone, the heater will enter the Hold Firing Rate Zone.

Hold Firing Rate Zone

In the Hold Firing Rate Zone, the control will hold modulation regardless of the flow reading. The firing rate will be held at the current firing rate in an attempt to prevent the ΔT from increasing further. If the ΔT drops below this zone, heater operation will release to PID control. If the ΔT continues to increase, the control will enter the Min Firing Rate Zone.

Min Firing Rate Zone

If all other attempts to prevent the ΔT from increasing fail, the firing rate will drop to minimum firing rate as a last attempt to prevent a ΔT fault. If this action is effective, the ΔT will drop and the heater will attempt to find the optimum point of operation. However, if this action is not successful and the ΔT continues to climb, and the MAX ΔT threshold is exceeded, and the burner is forced to cycle.

Glycol % Setting

The XVersL product is equipped with algorithms that will ensure optimum operation when using different glycol concentrations as the heat media. From the VERSA IC® touchscreen, the user must select a glycol concentration. See **Table S**.

This setting can be found within the Adjust Menu within System Settings.

NOTE: The factory default value is 50% glycol concentration. Restoring factory defaults WILL NOT reset this value.

When replacing the VERSA IC®, it is important to update the glycol percentage value as needed for proper system operation.

Model No.	Max Firing Rate %	100	91.49	89.19	84.68	79.67
		Glycol %	0%	25%	30%	40%
Model No.	Min Flow GPM @ Max DT @ Max Firing Rate					
406L	399000	10.44	10.90	10.99	11.30	11.80
506L	500000	13.00	13.80	14.10	14.70	15.30
606L	600000	15.70	16.80	17.40	18.00	19.50
726L	725000	18.60	20.10	20.70	21.60	22.80
856L	850000	22.00	23.70	24.30	25.50	27.30

Table S. Max Allowed Firing Rate @ Various Glycol Concentrations

The glycol protection will reduce the maximum firing rate, but will also change the entire heating profile depending on the model size. See **Figure 52**.

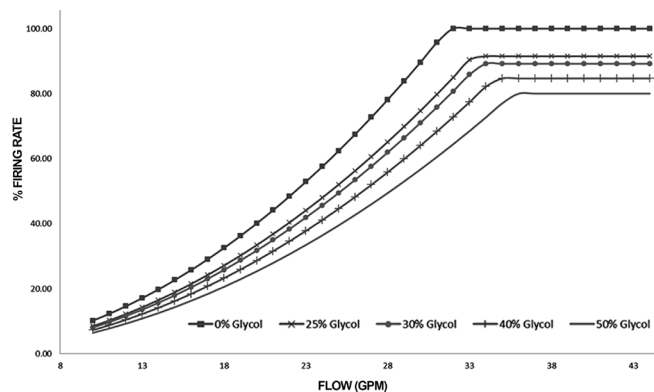

Figure 52. Glycol Operation Chart

Vent Protection

The XVersL boilers are equipped with a vent temperature sensor located at the rear of the boiler. See **Figure 4**.

The vent protection algorithm will anticipate a flue temperature overshoot and adjust the firing rate of the boiler to prevent excessive flue temperatures from occurring.

NOTE: The factory default is set to “PVC”.

During commissioning of the boiler, the vent material must be selected in the Adjust Menu (Submenu of System Settings) to indicate the vent material installed on the boiler.

The settings for the Vent Protection include:

NOTE: Use only certified vent material ANSI/ASTM D1785 Sch 40 PVC, ANSI ASTM F441 Sch 40 CPVC.

- **Vent Material.**
PVC (149°F/65°C), ASTM/ANSI
CPVC (194°F/90°C), ASTM/ANSI
PPS (Polypropylene) (230°F/110°C),
Stainless Steel (AL29-4C)
- **Vent Differential.** Subtractive value from max vent temperature that defines when the control will take action to prevent unit from reaching the max vent temperature. Default 10°F (5.6°C) selectable from 1°F (0.6°C) - 20°F (11°C).
- **Vent Rate.** This value defines the max firing rate the boiler will be allowed to operate at when Vent Protection is active.

If the vent temperature exceeds the allowable limit for the vent material selected, the burner will cycle. This is an automatic reset function and as soon as the vent temperature drops to an acceptable level, the boiler will return to normal operation.

NOTE: The use of PVC/CPVC will require the user to limit the maximum setpoint of the boiler in the Adjust menu.

Control Devices

WARNING: Installation, adjustment and service of boiler controls, including timing of various operating functions, must be performed by a qualified installer, service agency or the gas supplier. Failure to do so may result in control damage, boiler malfunction, property damage, personal injury, or death.

WARNING: Turn off the power to the boiler before installation, adjustment or service of any boiler controls. Failure to do so may result in board damage, boiler malfunction, property damage, personal injury, or death.

CAUTION: This appliance has provisions to be connected to more than one supply source. To reduce the risk of electric shock, disconnect all such connections before servicing.

CAUTION: Risk of electric shock: More than one disconnect switch may be required to de-energize the equipment before servicing.

Motorized Isolation Valve (Shipped Loose)

The boiler is equipped with a relay output to control an isolation valve as follows:

- Boiler output energized = Isolation valve CLOSED
- Boiler output de-energized = Isolation valve OPEN

The operation above may be manually adjusted by manually inverting the operation of the isolation valve and using the opposite dry contact of the relay output.

24VAC supply voltage for the isolation valve actuation is also available at the rear of the boiler in the wiring box, next to the isolation valve relay output.

When running a primary piping system configuration or any cascade system, at least one isolation valve should be open at all times to allow the system to flow freely.

CAUTION: Failure to set up the Isolation Valve correctly may damage the boiler/system pump causing non-warrantable failures.

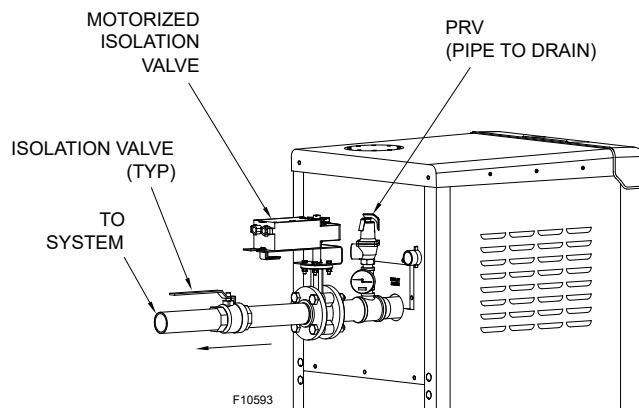

Figure 53. Motorized Isolation Valve Installation

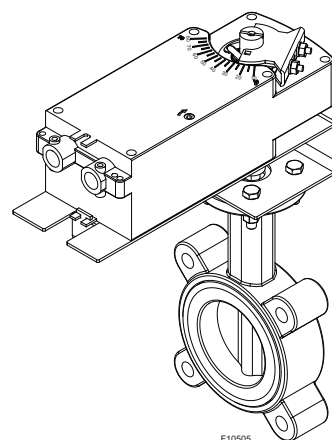

Figure 54. Motorized Isolation Valve

Ignition Control Functions

When there is a call for heat, and all safeties are closed and minimum flow rate detected, then the combustion air blower starts to purge air from the combustion chamber. After the pre-purge, the igniter is energized.

The standard ignition module will lock-out after failing to light 3 times during a call for heat. To reset the lock-out, press and release the RESET button located adjacent the user interface. The control will automatically reset after 1 hour. When in lock-out the control will run the blower through a post-purge cycle.

The single-try ignition module (part of the CSD-1 option) will attempt to light only one time before lock-out occurs. To reset the lock-out, press and release the RESET button located adjacent the user interface.

Turning off the power to the boiler WILL NOT reset the single-try ignition module.

NOTE: Ignition modules are common for all XVersL model sizes. However, model-specific operating parameters are defined by their respective ID cards.

3-Position Rocker Switch

This boiler is equipped with a 3-position rocker switch located on the front control panel (adjacent the touchscreen display).

The 3-positions of this switch are:

- Right = OFF
- Middle = IDLE
- Left = RUN

When the switch is in the OFF position, there is power to the control and the boiler is not operational.

WARNING: There is still live electricity inside the boiler - disconnect electrical supply to the boiler before servicing the boiler.

When the switch is in the IDLE position, power is supplied to the control to allow for review/adjustment of settings, but the boiler will not fire.

CAUTION: The Enable/Disable signal may be overridden when the VERSA control is configured for MODBUS "TEMP" or "RATE". Disable MODBUS prior to servicing the boiler.

When the switch is in the RUN position, the boiler is enabled to operate based on the water temperature and target temperature setpoint.

High Limit - Manual-Reset

This boiler is equipped with a fixed-setting manual-reset high limit temperature device as standard. This sensor includes both high limit and outlet sensing elements. The boiler may also have an additional optional adjustable manual-reset high temperature device.

The optional manual-reset high limit is located inside the cabinet on the upper right corner post.

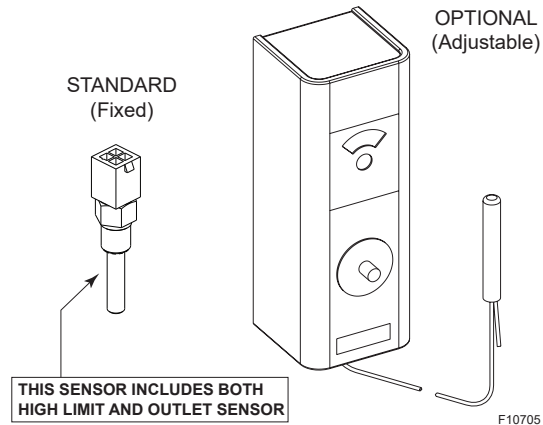

Figure 55. High Limit (Manual-Reset) (MRHL)

The fixed-setting manual-reset high limit is built into the PIM, and utilizes a dual thermistor sensor located on the outlet. See **Figure 2**.

H 200°F (93°C)

To reset a high limit lock-out, press and release the RESET button located adjacent the user interface or the RESET button located on the face of the optional MRHL.

High Limit - Auto-Reset (Optional)

This boiler may be equipped with an optional adjustable auto-reset high limit temperature device.

The optional adjustable auto-reset high limit is located inside the cabinet on the upper right corner post. See **Figure 2**. Adjust the setting to approx. 20°F (11°C) above desired outlet temperature.

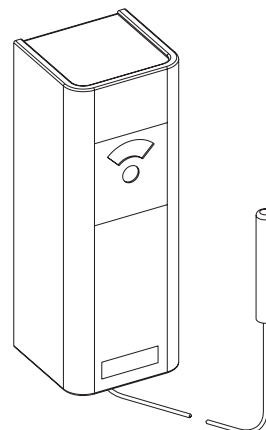

Figure 56. Adjustable High Limit (Auto-Reset)

Flow Switch (Optional)

This optional device, dual-purpose control, mounted and wired in series with the main gas valve, shuts off the boiler in case of pump failure or low water flow. See **Figure 1**.

Low flow causing the flow switch to open during operation will create a soft lockout that will automatically reset after 15 minutes. This functionality will prevent short-cycling of the burner due to marginal water flow.

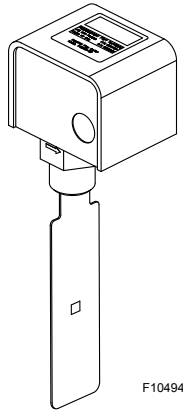

Figure 57. Flow Switch

Low Water Cut-Off

The low water cut-off automatically shuts down the burner whenever water level drops below the level of the sensing probe. See **Figure 1**. A 5-second time delay prevents premature lockout due to temporary conditions such as power fluctuations or air pockets. The low water cut-off control is located in the control box.

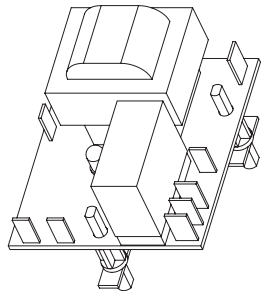

Figure 58. Low Water Cut-Off

High and Low Gas Pressure Switches (Optional)

The optional low gas pressure switch mounts upstream of the gas valve (on the inlet flange to the gas valve) and is accessible through the removable access panels on the top or front of the boiler to reset the gas pressure switch, as necessary. See **Figure 1**. It is used to ensure that sufficient gas pressure is present for proper valve/regulator performance. The low gas pressure switch automatically shuts down the boiler if gas supply drops below the factory setting of 3" WC for natural gas or propane gas.

The high gas pressure switch is standard, and is mounted downstream of the gas valve. See **Figure 1**. If the gas pressure regulator in the valve fails, the high gas pressure switch automatically shuts down the burner.

The low gas pressure switch must be set at 3" WC for either Nat or Propane Gas. The high gas pressure switch must be set at 3" WC for either Nat or Propane Gas. Scales on switches are approximate. Use manometer to set the switch settings.

Operation of either the High or Low Gas Pressure Switch will turn on an LED inside the switch housing. Push the top of the plastic switch housing as shown in **Figure 59** to reset a tripped pressure switch. The LED will go out when the switch is reset. No bleed line is required.

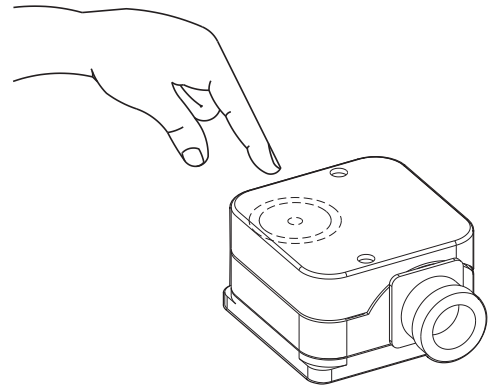

Figure 59. High/Low Gas Pressure Switch

Blocked Vent Switch

This boiler is equipped with a blocked vent pressure switch to prevent the operation of the boiler when too much of the vent is blocked. This switch is located on the right side of the boiler near the front. See **Figure 2**.

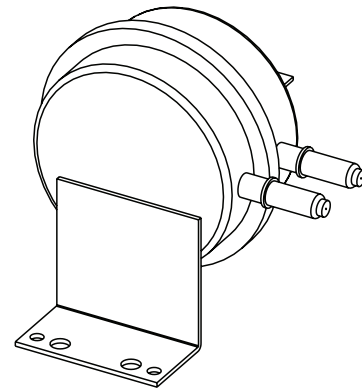

Figure 60. Blocked Vent Switch

Condensate Switch

The condensate switch is located lower rear (right corner) of the boiler. See **Figure 3**. Remove the lower access panel to access the condensate switch. The switch will shut the unit down in the event of excessive condensate in the condensate compartment of the heat exchanger.

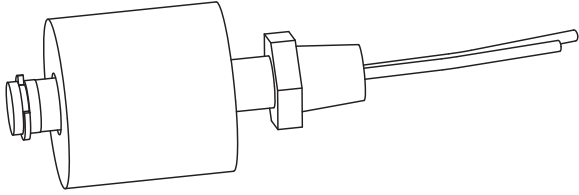

Figure 61. Condensate Switch

Flow Meter (Optional)

The boiler may be equipped with an optional flow meter which measures flow through the boiler and the control adjusts firing rate based on flow. See **Figure 51**.

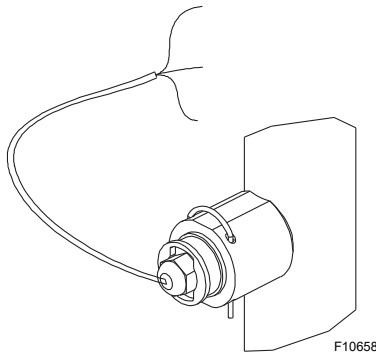

Figure 62. Flow Meter

Vent Temp Sensor

The boiler is equipped with a vent temperature sensor. Upon initial installation/commissioning of the boiler, the vent material used for installation (PVC, CPVC, PP, or SS) must be entered into the control. See **Figure 4**. The factory default value is "PVC".

The control uses the input from this sensor to automatically reduce firing rate should the vent temperature approach the vent material temperature limits.

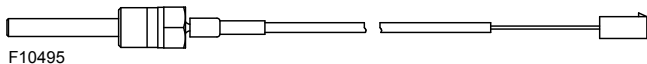

Figure 63. Vent Temp Sensor

User Interface

The touchscreen user interface uses a high definition 4.3" (109 mm) capacitive screen. It includes an extensive graphical library used to represent different pipe configurations, error location, and operation of the unit.

The touchscreen menu bar becomes visible at the bottom of the screen allowing navigation through additional icons (View, Adjust, Boiler, Tools, Document Viewer and Wi-Fi).

For detailed descriptions of the various screens, page flows and basic instructions, consult the Touchscreen Quick Start User Guide (241630) and VERSA IC® Manual (241493).

If your unit has Raymote installed, refer to the Raymote installation and operation manual (241788).

Adjusting the XVersL Setpoint

Use the MENU button to open the menu options, select the ADJUST menu, go to System Settings page. Once in the system settings screen use the Setpoint item. Adjust the setpoint using the UP and DOWN arrow.

After making the setpoint selection press SET button to apply the changes (a confirmation bar will turn green showing that value has been applied). Minimum setpoint is 50°F (10°C); maximum is 200°F (93°C) for XVersL models. The default setpoint is 180°F (82°C).

View Menu

The VIEW menu is the default menu. See **Table T**. It displays sensor temperatures, the modulation rate of the blower, boiler cascade status, pump operation and CFH information. Some of the items displayed are mode specific and are only observable when its corresponding mode is active.



Figure 64. Use Interface

Menu - Initial Adjustment

To change settings on the touchscreen, press MENU icon, Adjust icon, System settings, System menu to open Adjust Settings menu. The ADJUST menu allows the installer to make adjustments to items shown in **Table U**.

Refer to the VERSA IC® Manual (241493) for detailed setup instructions.

Item	Application	Description
OUTDOOR	H MODE 1, 2, 3	Outdoor air temperature, available when TARGET = RSET in ADJUST menu
Target	H MODE 1, 2, 3	Current target temperature, available when Target = SETP in the ADJUST menu (default), and (EMS / MODB)
SUPPLY	H MODE 1, 2, 3	Current system supply temperature
IND SUPPLY	H MODE 3	Current temperature being supplied to the indirect system
Boil OUTLET	All	Current boiler outlet temperature
Boil INLET	All	Current boiler inlet temperature
Boil ΔT	All	Current temperature difference between boiler outlet and boiler inlet
DHW SUPPLY	H MODE 2, 3	Current indirect DHW supply temperature
TANK	WH	Current Tank Temperature
FOLLOWERS	CASCADE MASTER	Number of followers on CASCADE
BOILER STATUS	All	IDLE, PREPURGE, IGNITION MOD RATE %, POSTPURGE, SOFTLOCK, HARDLOCK

Table T. View Menu

Item	Application	Range	Description	Default
TARGET	H MODE 1, 2, 3	RSET <> SETP	RSET = Outdoor Reset, SETP =Setpoint	SETP
MODE	H MODE 1, 2, 3	1,2,3	Piping and application configuration	1
SETPPOINT	H MODE 1, 2, 3	50°F to 200°F (10°C to 93°C)	Boiler target temperature while a heat demand is present for setpoint operation	180°F (82°C)
OUT START	H MODE 1, 2, 3	35°F to 85°F (2°C to 29°C)	Outdoor starting temperature - outdoor reset	70°F (21°C)
OUT DESIGN	H MODE 1, 2, 3	-60°F to 45°F (-51°C to 7°C)	Outdoor design temperature - outdoor reset	10°F (-12°C)
Boil START	H MODE 1, 2, 3	35°F to 150°F (2°C to 66°C)	Starting boiler target temp when the outdoor temperature is at outdoor start outdoor reset	70°F (21°C)
Boil DESIGN	H MODE 1, 2, 3	70°F to 200°F (21°C to 93°C)	Design boiler target temperature when the outdoor temperature is at outdoor design outdoor reset	180°F (82°C)
TARGET MAX	H MODE 1, 2, 3	100°F (38°C) to PIM value*	Maximum target system temperature	200°F (93°C)
TARGET MIN	H MODE 1, 2, 3	OFF, 50°F to 190°F (10°C to 88°C)	Minimum target system temperature	50°F (10°C)
TARGET DIFF	H MODE 1, 2, 3	2°F to 42°F (1°C to 23.3°C)	Differential for target system temperature	10°F (5.6°C)
IND SENSOR	H MODE 1, 2, 3	OFF <> ON	Selects whether a DHW sensor is used for indirect DHW tank	OFF
IND SETP	H MODE 2, 3	OFF, 50°F (10°C) to 180°F (82°C)	Target Indirect DHW Temperature, requires IND SENSOR = ON	140°F (60°C)
DHW DIFF	H MODE 2, 3	2°F to 10°F (1°C to 5.6°C)	Target indirect DHW tank temp, requires IND SENSOR = ON	6°F (3.4°C)
GLYCOL	IDLE only	0% - 50%	Glycol concentration	50%
Delta T Offset	H MODE 1,2,3	2°F to 15°F (1°C to 8.5°C)	DT Offset (Flow Warning threshold)	10°F
Isol Valve ON/OFF	IDLE only	0:CLOSE, 1:OPEN	Manual Open / Close of ISOL Valve	1, OPEN
VENT MATERIAL	IDLE only	PVC, CPVC, PPS, SS	Defines VENT Piping material. To update value unit must be in IDLE status. (Tap 6 times on setting label to enable SET button)	PVC
VENT DIFF	IDLE only	1°F to 20°F (1°C to 11.2°C)	Subtractive differential of VENT Temperature. This value sets the threshold for VENT protection to be active	10°F (5.6°C)
VENT RATE	IDLE only	MIN Firing Rate to 80%	Forced firing rate when VENT protection is present	50%
# ISOL Valves Open	Cascade Master Only	1, 2, 3, 4	Number of ISOL Valves open in a cascade configuration	1
Cascade	Cascade Only	OFF<>5<>6<>7<>8	Cascade ID only applicable to Tn_bus follower units	OFF
Cascade Type	Cascade Master Only	SEQ, PAR	Cascade operation type	SEQ
Cascade MIN Flow Offset	Cascade Master Only	-25 to 15 GPM	Overrides MIN flow condition for next unit in cascade to allow next unit to be called to fire sooner or later.	0
Cascade Alarm	Cascade Master Only	ON<>OFF	Cascade Alarm to all units in case of any unit presents alarm.	ON
Flow Override	IDLE only	0,MIN % to 80%	Overrides MIN Flow condition for ignition sequence, setting expires in 24hrs.	0
IND SUPPLY	H MODE 2, 3	OFF, 50°F (10°C) to PIM value*	Target boiler temperature for the DHW heat exchanger during indirect DHW operation, requires IND SENSOR = OFF	180°F (82°C)
DHW PRIORITY	H MODE 2	OFF <> ON	Selects whether or not Indirect DHW priority is active during indirect DHW operation	OFF
PRI OVR	H MODE 2, 3	Au, 0:10hr to 2:00hr	Sets the length of the indirect DHW priority override time	1:00hr
SYS PURGE	All	OFF, 0:20min to 20:00min	Sets the length of the system pump post purge	20 seconds
MIX TYPE	H MIX	H (VALVE, PUMP, PLNT) WH (1 <> 2)	Selects the type of control depending on pipe configuration for CWP	H VALVE
MIX TARGET	H MIX	50°F to 140°F (10°C to 60°C)	Inlet Target Temperature	120°F (49°C)
MIX LOCK	H MIX	OFF <> ON	The equipment will trigger a warning when "MIX Target" is not reached within 7 minutes. MIX LOCK = ON; Alarm and lockout, MIX LOCK = OFF; Alarm only	OFF
MIX TRIM	H MIX	-5 to 5	This adjustment is for various types and sizes of units as well as various actuator motor speeds and types supplied by Raypak	0
MIX SPEED	H MIX	SLOW <> MED <> FAST	This setting defines speed of response	MED
MIX INV	H MIX	OFF <> ON	Relates to the use of spring return actuators with a proportional valve	OFF
WWSD	H MODE 1, 2, 3	40°F to 100°F (4°C to 38°C)	The system warm weather shutdown temperature outdoor reset, requires TARGET = RSET	70°F (21°C)
UNITS	All	deg F <> deg C	Show units using icons in display	deg F
MODBUS	All	OFF <> MNTR <>TEMP <> RATE	ModBus Operating Mode: Off, Monitor, Temp Control, Rate Control	MNTR
ADDRESS	All	1 to 247	ModBus slave address	1
DATA TYPE	All	RTU <> ASCI	Modbus data type	RTU
BAUD RATE	All	2400 <> 9600 <> 19K2 <>57K6 <> 115K		19K2
PARITY	All	NONE <> EVEN <> ODD		EVEN

* Maximum operator dial setting.

Table U. Setup/Adjust Menu

Boiler Menu

The Boiler Menu displays various items regarding ignition, temperature monitoring, and modulation rates. As well as software and hardware information. Up to 15 error codes can be reviewed in the Boiler Menu.

Item	Application	Description
BOILER 1	ALL	Displays Boiler for operation
BOILER 2	CASCADE	Displays Ft_bus Boiler for cascade operation
BOILER 3	CASCADE	Displays Ft_bus Boiler for cascade operation
BOILER 4	CASCADE	Displays Ft_bus Boiler for cascade operation
CASCADE	TN-BUS CASCADE FOLLOWER	Set Cascade ID for TN-bus follower, see VERSA IC® Manual (241493).
IGNITION	ALL	<p>IDLE=no CFH; PREP=pre-purge or inter-purge between trials for ignition; IGN=trial for ignition; BURN=burner operating; POST=post purge; HARD=a hard lockout fault has occurred requiring manual-reset (Ignition Lockout or manual high limit); and SOFT=a soft lockout fault has occurred which interrupts the heating cycle (any safety other than ignition or manual high limit)</p> <p>The CFH will resume after the soft lockout fault has been corrected and a 15 min. waiting period has expired</p>
VENT WALL	ALL	Monitors vent temperature and adjust firing rate if vent temperature approaches limit for vent material installed/selected
LIMIT TEMP	ALL	Current Outlet-Limit temperature
EMS Vdc	ALL	Current EMS signal in Volts DC
FIRE RATE	ALL	PIM firing rate
SPEEDX 1000	ALL	Blower speed in revolutions per minute (rpm) x 1000
OUTLET MAX	H Mode 1, 2, 3	Defines Max Outlet temperature offset above Target Setpoint (Press and hold up and down arrows for 3 seconds to enable adjustment). See VERSA IC® Manual (241493)
OPERATOR	ALL	Operator Potentiometer setting on PIM
DIFF	ALL	Current auto differential – Fixed by PIM
Pump Post	ALL	Sets the length of the boiler pump purge
FLAME CUR	ALL	Flame current in micro-amps (µA)
MASS	ALL	Thermal mass recovery see VERSA IC® Manual (241493)
IDENTITY	ALL	Identifies the unit as boiler, water boiler or pool boiler
IGN TYPE	ALL	PIM Board type
ID CARD	ALL	Identifies Raypak Identity Card
SW ID	ALL	PIM Software identification number
ERROR MESSAGE	ALL	Current Error Message
MIN MOD ADJUST	ALL	Overrides PIM Low Fire Mod value up to 60%

Table V. Boiler Menu

Monitor View

The Monitor View displays critical Boiler information, such as, Cycle times, Run times, and Maximum/Minimum temperature readings depending on the setup.

Item	Application	Description
RUN TIME Burner 1	All	Burner run time (hours). Press UP/DOWN for 1 sec to clear
Cycles Burner	All	Number of burner cycles. Press UP/DOWN for 1 sec to clear
RUN TIME Boiler pump	All	Boiler pump run time (hours). Press UP/DOWN for 1 sec to clear
RUN TIME System pump	All	System pump run time (hours). Press UP/DOWN for 1 sec to clear
RUN TIME DHW pump	H MODE 2, 3	DHW pump run time (hours). Press UP/DOWN for 1 sec to clear
OUTLET HI	All	Records the highest boiler outlet temperature. Press UP/DOWN for 1 sec to clear
OUTLET LO	All	Records the lowest boiler outlet temperature. Press UP/DOWN for 1 sec to clear
INLET HI	All	Records the highest boiler inlet temperature. Press UP/DOWN for 1 sec to clear
INLET LO	All	Records the lowest boiler inlet temperature. Press UP/DOWN for 1 sec to clear
DELTA T	All	Captures the highest Delta T Temperature recorded. Press UP & DOWN buttons for 3 sec to clear this entry
OUTDOOR HI	H MODE 1, 2, 3	Records the highest outdoor temperature. Press UP/DOWN for 1 sec to clear
OUTDOOR LO	H MODE 1, 2, 3	Records the lowest outdoor temperature. Press UP/DOWN for 1 sec to clear
SYSTEM HI	All	Records the highest supply temperature. Press UP/DOWN for 1 sec to clear
SYSTEM LO	All	Records the lowest supply temperature. Press UP/DOWN for 1 sec to clear
IND HI	H MODE 1, 2, 3	Records the highest Indirect supply temperature. Press UP/DOWN for 1 sec to clear
IND LO	H MODE 1, 2, 3	Records the lowest Indirect supply temperature. Press UP/DOWN for 1 sec to clear
TANK HI	WH	Records the highest TANK temperature. Press UP/DOWN for 1 sec to clear
TANK LO	WH	Records the lowest TANK temperature. Press UP/DOWN for 1 sec to clear
PIM DIP SWITCHES		PIM DIP SW configuration
VERSA DIP SWITCHES		VERSA DIP SW Configuration
PIM SW Revision		Software revision number

Table W. Monitor View

Toolbox Menu

The Toolbox Menu logs all error codes from the VERSA and PIM, as well as other functions. For detailed descriptions of the various screens, page flows and basic instructions, consult the Touchscreen Quick Start User Guide (241630) and VERSA IC[®] Manual (241493).

Item	Description
Lookup Active Error	Look up and display the active error info
USER TEST	Select ON to start the function. The setting returns to default after the test is run
MAX HEAT	Select ON to start the function. The setting will time out to OFF after 24 hours or can be set to OFF again by the user. See VERSA IC [®] Manual (241493) for details
P/N XXXXXX	Software number of the Raypak VERSA
DEFAULTS	Resets to factory settings. Press UP and DOWN for 1 second to show CLR and load factory defaults to all settings. This will also clear all history
HISTORY <i>lookup logged error</i>	Displayed when an error code is present. 1 indicates the most recent error code. Press UP and DOWN for 1 second to clear the error logs

Table X. Toolbox Menu

Outdoor Reset Concept

The Temperature controller can change the System Setpoint based on outdoor temperature (Outdoor Reset). The temperature controller varies the temperature of the circulating heating water in response to changes in the outdoor temperature. The heating water temperature is controlled through the modulation and/or sequencing of the cascade. The Temperature controller can also control the system circulating pump with an adjustable Outdoor Cutoff.

When the outdoor temperature is above the Outdoor Cutoff, the pump is turned off and no heating water is circulated through the system. When the outdoor temperature drops below the Outdoor Cutoff, the system pump relay is activated and the heating water circulates through the system. The temperature of the heating water is controlled by the Reset Ratio, Water Offset, and changes with the outdoor temperature.

Reset Ratio/Outdoor Reset

When a building is being heated, heat escapes through the walls, doors, and windows to the colder outside air. The colder the outside temperature, the more heat escapes. If you can input heat into the building at the same rate that it is lost out of the building, then the building temperatures will remain constant. The Reset Ratio is an adjustment that lets you achieve this equilibrium between heat input and

heat loss. The starting point for most systems is the 1.00 (OD):1.00 (SYS) (Outdoor Temperature: Heating Water Temperature) ratio. This means that for every degree the outdoor temperature drops, the temperature of the heating water will increase one degree.

With the VERSA, both ends of the slope are adjustable. It is factory set at 70°F (21°C) water temperature (Boil START) at 70°F (21°C) outdoor air (OUT START), and 180°F (82°C) water temperature (Boil DESIGN) at 10°F (-12°C) outdoor air (OUT DESIGN).

Each building has different heat loss characteristics. A very well insulated building will not lose much heat to the outside air, and may need a Reset Ratio of 2.00 (OD):1.00 (SYS) (Outdoor: Water). This means the outdoor temperature would have to drop 2 degrees to increase the water temperature 1 degree. On the other hand, a poorly insulated building may need a Reset Ratio of 1.00 (OD):2.00 (SYS). This means that for each degree the outdoor temperature dropped the water temperature will increase 2 degrees.

The VERSA Reset Ratio allows for full customization to match any buildings heat loss characteristics. A heating curve that relies not only on Outdoor temperature but also on the type of radiation will improve heat comfort. The user can fine tune these adjustments based on the specific building need.

Reset Ratio Settings

The controller uses the four following settings to determine the reset ratio:

1. Boiler Start (**Boil START**). The Boil START temperature is the theoretical boiler supply water temperature that the heating system requires when the outdoor air temperature equals the OUT START temperature setting. The Boil START is typically set to the desired building temperature.
2. Outdoor Start (**OUT START**). The OUT START temperature is the outdoor temperature at which the control provides the Boil START water temperature to the system. The OUT START is typically set to the desired building temperature.
3. Outdoor Design (**OUT DESIGN**). The OUT DESIGN is the outdoor temperature that is typical coldest annual temperature where the building is located. This temperature is used when completing heat loss calculation for the building.
4. Boiler Design (**Boil DESIGN**). The Boil DESIGN temperature is the water temperature required to heat the boiler zones when the outdoor air is as cold as the OUT DESIGN temperature.

Warm Weather Shut Down (WWSD)

When the outdoor air temperature rises above the WWSD setting, the control turns on the WWSD segment in the display. When the control is in the Warm Weather Shut Down, the Dem 1 segment is displayed if there is a heat demand. However, the control does not operate the boiler to satisfy this demand. The control continues to respond to DHW demands.

Reset Ratio

The controller uses the following four settings to calculate the Reset Ratio (RR). For example, when using the default values, the RR is:

$$\text{RESET RATIO} = \frac{(\text{OUTDOOR START} - \text{OUTDOOR DESIGN})}{(\text{BOILER DESIGN} - \text{BOILER START})}$$

$$\text{RR} = (70 - 10) / (180 - 70) = 0.55$$

Therefore, the RR is 0.55:1 (Outdoor : Water).

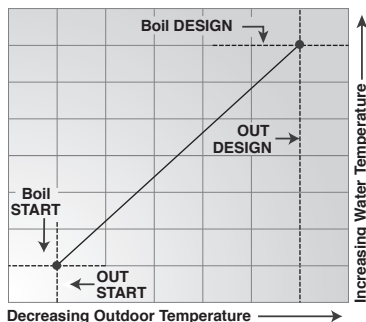

Figure 65. Reset Ratio

NOTE: The wiring diagrams in this manual show all standard options. Refer to the large wiring diagram provided with your boiler for options installed on your specific unit(s).

7. START-UP

NOTE: The following steps must be performed by a factory-trained technician.

Pre Start-up

Filling System (Heating Boilers)

Fill system with water. Purge all air from the system. Lower system pressure. Open valves for normal system operation, and fill system through feed pressure. Manually open air vent on the compression tank until water appears, then close vent.

Air Purge

Purge all air from system before boiler operation. This can normally be accomplished by opening a down-stream valve.

▲ CAUTION: An air vent valve should be field-installed at the highest point in the system for proper operation.

Venting System Inspection

1. Check all vent pipe connections and flue pipe material.
2. Make sure vent terminations are installed per code and are clear of all debris or blockage.
3. Ensure vent material has been inputted into the VERSA IC®.

Lighting Instructions/Warnings

For Your Safety

This appliance has a direct spark igniter. It is equipped with an ignition device which automatically lights the burners. Do not try to light the burners by hand.

▲ WARNING: If you do not follow these instructions exactly, a fire or explosion may result causing property damage, personal injury or loss of life.

BEFORE OPERATING, smell all around the appliance area for gas. Be sure to smell near the floor because some gas is heavier than air and will settle on the floor.

WHAT TO DO IF YOU SMELL GAS:

- Do not try to light any appliance.
- Do not touch any electrical switch; do not use any telephone in your building.
- Immediately call your gas supplier from a neighbor's telephone. Follow the gas supplier's instructions.
- If you cannot reach your gas supplier, call the fire department.

- Use only your hand to turn the gas control valve handle. Never use tools. If the handle will not turn by hand, do not try to repair it; call a qualified service technician. Forced or attempted repair may result in a fire or explosion.
- Do not use this appliance if any part has been under water, immediately call a qualified service technician to inspect the appliance and to replace any part of the control system and any gas control which has been under water.
- Check around unit for debris and remove combustible products, i.e. gasoline, etc.

Pre Start-up Check

1. Verify the boiler is filled with water.
2. Check system piping for leaks. If found, repair immediately.
3. Vent air from system. Air in system can interfere with water circulation.
4. Purge air from gas line to boiler.

Initial Start-up

Required tools

- (1) 12-0-12 (24" scale) U-tube manometer
- (2) 6-0-6 (12" scale) U-tube manometer
- Screwdrivers (assorted sizes and shapes)
- (1) Crescent wrench (8" or 10")
- (1) Multi-meter
- (1) Flue gas analyzer

(Metric Allen wrenches will be required for servicing the gas valve, but not during start-up)

NOTE: Technician performing initial start-up must carry a calibrated combustion analyzer to ensure desired combustion levels are achieved.

Preparation

Check Power Supply

With multimeter at incoming power, check voltage as applicable:

▲ WARNING: Do not turn on gas at this time.

Attach Manometers to Measure Pressures

NOTE: Digital manometers are not recommended.

1. Turn off main gas valve.
2. Attach (1) 12" scale manometer to an upstream bleedle valve on the gas supply pipe to the boiler (Measure point "A" in **Figure 66**).
3. Attach (1) 24" scale manometer to the manifold pressure tap on the gas valve (Measure point "B" in **Figure 66**).
4. Attach (1) 12" scale manometer on the fan suction pressure hose. Pull black cap from the air pressure tee as shown in **Figure 66** and connect the manometer (Measure point "C" in **Figure 66**).

NOTE: Retain caps for reinstallation later.

Check Gas Supply Pressure

1. Slowly turn on main gas shutoff valve.

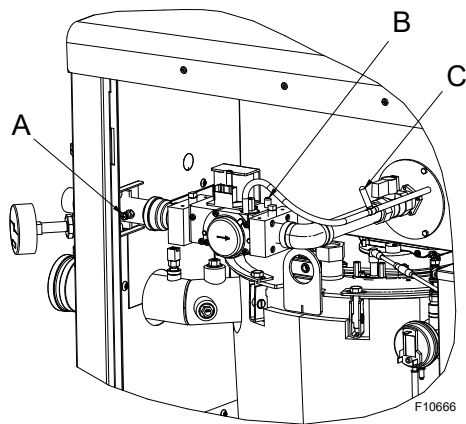

MODELS 406L-506L

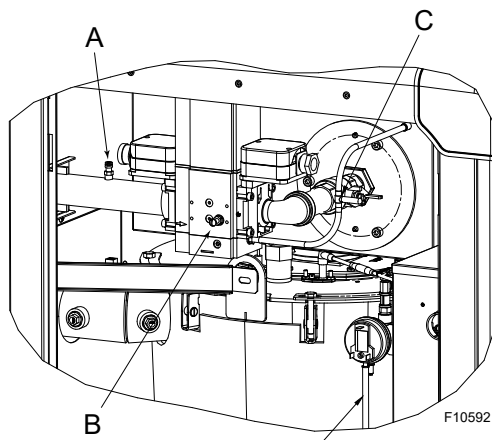

MODELS 606L-856L

FROM BLOCKED VENT

A = Gas Supply Pressure
B = Gas Manifold Pressure
C = Air Pressure Tee

Figure 66. Gas Pressure Measurement Locations

2. Read the gas supply pressure from the manometer; minimum supply pressure for natural gas is 4" WC, recommended supply is 7" WC, minimum supply pressure for propane gas is 4" WC, recommended supply is 11" WC (dynamic readings, full fire input).
3. If the gas pressure is greater than 14" WC, turn off the main gas shutoff valve, upstream of the boiler.

Start-Up

NOTE: The values in **Table Y** and **Table Z** represent the conditions when the boiler is at full firing rate at sea level.

NOTE: Pressure and combustion data are provided with the boiler.

1. Turn power on.
2. Turn on the boiler, switch Enable/Disable rocker switch to top position to enable CFH wait approximately 15 seconds after the blower starts, the igniter should start to glow (observable through the observation port located on top of the combustion chamber. Gas valve should open in 45-60 seconds.
3. The boiler ignites at 30% to 40% of full rate (as indicated on the touch screen display of the temperature controller located behind the front panel).
4. If the burner fails to light on the first 4-second trial for ignition, it will try for ignition up to three times before going into lockout with the standard ignition module. If the boiler is equipped with the optional single-try ignition module, it will go into lockout.
5. Wait until the controller indicates 100% on the firing rate display screen (approximately 30 seconds).

Blower Check

1. Check blower suction using the manometer attached to the air pressure tee (connection C) as shown in **Figure 66**, with the boiler firing at 100% input. The reading should be as noted in **Table Y** for both natural and propane gas.

NOTE: Retain the black plastic cap removed to install the manometer. It needs to be replaced when the manometer is removed.

NOTE: Technician performing initial start-up must carry a calibrated combustion analyzer to ensure desired combustion levels are achieved.

2. CO₂ and CO levels must be checked at 100% fire rate. When firing at 100%, the desired boiler combustion CO₂ is 8.6 to 9.4% for natural gas and 10.0 to 10.8% for propane gas with CO less than 100 ppm. If this combustion cannot be achieved with the blower suction within the tolerances specified in **Table Y**, contact the factory.

- CO₂ and CO levels must be checked at minimum fire. When firing at minimum fire, the desired boiler combustion CO₂ is 7.5 to 9.5% for natural gas and 9.0 to 11.0% for propane gas with CO less than 100 ppm. If CO₂ values are not within the ranges specified; and if CO is above 100 ppm in either case, stop running the unit and contact your Raypak representative. Visit www.raypak.com for contact information.

⚠ WARNING: Improper installation, adjustment, alteration, service or maintenance can cause property damage, personal injury, exposure to hazardous materials or loss of life.

⚠ WARNING: The unit has been factory tested and pre-certified at the reference gas pressure as shown on the unit decal. If the desired CO₂ and CO values are not achieved at the listed air pressure in Table X within tolerance specified, contact your local Raypak Representative or Raypak factory for direction. Tampering with preset values can lead to poor performance of the unit and result in personal injury, death or property damage.

- If the CO₂ values and air pressure values (Table Y) are outside of the tolerances noted, the air shutter should be adjusted slightly to bring the values back into the nominal range. Close the shutter slightly (clockwise) to increase the negative air pressure or raise the CO₂ values. Open shutter slightly (counterclockwise) to lower the negative air pressure or lower the CO₂ values.

Manifold Check

- Check manifold gas pressure at the gas valve pressure tap (connection “B” in Figure 66). Refer to Table Z for natural and propane gas pressure ranges and tolerances.
- If the CO₂ ranges specified are not achieved with the pressure and tolerance ranges specified in Table Z, STOP – Call the your Raypak representative for directions on what to do next! Visit www.raypak.com for contact information.

Model No.	Air Pressure Setting ("WC)		Setting Tolerance
	Natural Gas	Propane Gas	
406L	-1.5	-1.6	+/-0.2 in.WC
506L	-2.9	-3.0	+/-0.2 in.WC
606L	-1.0	-1.0	+/-0.2 in.WC
726L	-0.5	-0.5	+/-0.1 in.WC
856L	-0.7	-0.7	+/-0.1 in.WC

Table Y. XVersL Air Pressure Settings

Model No.	Gas Manifold Pressure Setting ("WC)		Setting Tolerance
	Natural Gas	Propane Gas	
406L	-1.5	-1.6	+/-0.2 in.WC
506L	-2.9	-3.1	+/-0.2 in.WC
606L	-1.1	-1.2	+/-0.2 in.WC
726L	-0.6	-0.8	+/-0.1 in.WC
856L	-0.7	-0.9	+/-0.1 in.WC

Table Z. XVersL Manifold Pressure Settings

⚠ CAUTION: Special manifold and air settings may be required.

User Test

Set DIP switch #1 on the VERSA IC® to “ON”. On Touchscreen, click Menu icon, Tools icon, Systems Tools, Press “Start” to initiate User Test sequence.

- User Test START is displayed.
- Pressing Hold/Skip button advance through the user test.
- Ignition will occur for units that are enabled and there is a call for heat.

Number Field	Output Action
SYS	System Pump relay turns on
DHW	DHW Pump relay turns on
PMP 1	System and Boiler Pump relays turn on
CWP	CWP Proportional output
Boil 1	Ignite Boiler Burner
Min 1	Hold Boiler at Min Fire
Max 1	Ramp Boiler to Max Fire and hold

Table AA. User Test Fields

- On the first press of the Hold/Skip button, the test step is held and “HOLD” is flashed at 1Hz.
- On the second press of the Hold/Skip button, the test step is incremented.
- If boiler outlet temperature reaches the PIM Hi-Limit, the boiler will be ramped down to keep the temperature in a safe range.
- Press of the Hold/Skip button from Boiler Max will End the User Test function.
- CWP MUST be enabled (VERSA DIP #3) VALVE must be functioning during USER TEST.

NOTE: If USER TEST is performed with Cold Water Protection enabled (VERSA DIP 3 = ON), allow valve or VS pump test sequence to complete uninterrupted or a fault condition may occur.

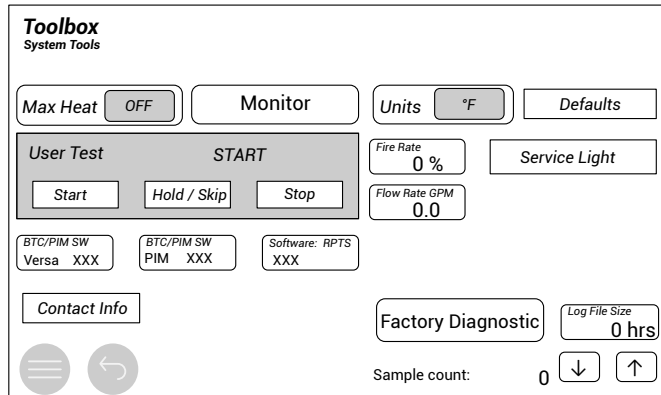

Figure 67. Touchscreen Toolbox Menu

Safety Inspection

1. Check all thermostats and high limit settings.
2. During the following safety checks leave manometers hooked up, check and record.
3. If other gas-fired appliances in the room are on the same gas main, check all pressures on the XVersL with all other equipment running.
4. Check thermostats for ON-OFF operation.
5. Check high limits for ON-OFF operation.
6. While in operation, check flow switch operation.
7. Check the low gas pressure switch (if provided). (For proper adjustment, use the attached manometers, if available, to set pressure. The scales on the switch are approximate only.) Low gas pressure switch (if provided) must be set at 3" WC for natural gas and propane gas.
8. Make sure that the high gas pressure switch is set to 3" WC for both natural gas and propane gas.

Finishing

Record all data on the "Start-up Checklist" located at the back of this manual.

Disconnect the manometers and reconnect the cap on the fan pressure tee and reinsert the sealing screws into the bleedle valves.

Start-up is complete and the boiler should be operating properly.

Follow-Up

Safety checks must be recorded as performed.

Turn boiler on. After main burner ignition:

1. Check manometer for proper readings.
2. Cycle boiler several times and re-check readings.
3. Remove all manometers and replace caps and screws.
4. Check for gas leaks one more time.
5. To prepare for possible "limp-along" operation (if communication is ever lost between the VERSA and the PIM), set the operator Setpoint potentiometer on the PIM to the desired target setpoint. (Refer to the VERSA IC[®] Manual.)

Leak Test Procedure: Dual-Seat Gas Valve

Proper leak testing requires three pressure test points in the gas train. Remove the top panel to access the gas valve for this test. See **Figure 66**.

Test point A is a bleedle valve located upstream of the combination gas valve on the supply manifold.

Test point B is a bleedle valve located between the two automatic gas valve seats.

Test point C is a bleedle valve located downstream of both automatic gas valve seats and upstream of the manual valve. See **Figure 68**.

These tests are to be conducted with the electrical power to the boiler turned OFF.

1. Manually close the downstream leak test valve.
2. Open the bleedle valve at test point A and connect a manometer to it. Verify that there is gas pressure and that it is within the proper range (NOTE: must not exceed 14" WC).
3. Open test point B and connect a rubber tube to it. Connect the other end of the tube to a manometer and look for a build-up of pressure. Increasing pressure indicates a leaking gas valve which must be replaced.
4. Next, close the upstream manual gas valve (field supplied) and remove the manometers from the bleedle valves in test point A and test point B. Connect a rubber tube from the test point A bleedle valve to the test point B bleedle valve and open the upstream manual gas valve. Make sure that test point A and B bleedle valves have been opened so as to allow gas to flow. This will bring gas pressure to the second valve seat.
5. Open the bleedle valve at test point C and connect a second rubber tube to it. Connect the other end of the tube to a manometer and look for a build-up of pressure. Increasing pressure indicates a leaking gas valve which must be replaced.

6. Remove rubber tube and manometers. Close each bleedle valve as the tubes are removed.
7. After no leakage has been verified at all valve seats and test valve, open downstream leak test valve and restore electrical power to the boiler.

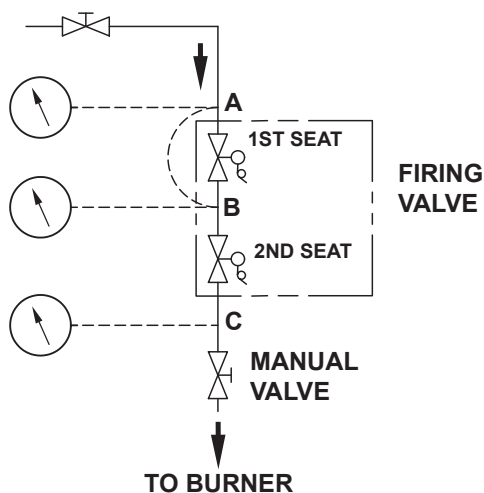

Figure 68. Leak Test Procedure

Post Start-Up Check

Check off steps as completed:

1. Verify that the boiler and heat distribution units are filled with water.
2. Open the caps on automatic air vent valves during the venting procedure.
3. Verify that air has been purged from the system.
4. Verify that air has been purged from the gas piping, and that the piping has been checked for leaks.
5. Confirm that the proper start-up procedures were followed.
6. Inspect burner to verify flame.
7. Test safety controls: test low water cut-off or additional safety controls for operation as outlined by manufacturer. Burner should be operating and should go off when controls are tested. When safety devices are restored, burners should re-ignite after pre-purge time delay.
8. To test the fixed manual-reset high limit built into the PIM, first set DIP switch #8 on the PIM to the ON position. This will activate a Commission Test Mode which will turn on the amber Alarm/Test LED on the PIM. The fixed high limit setting is temporarily overridden to match the setpoint potentiometer position on the PIM. The high limit can now be adjusted by the potentiometer to assist in commission testing and verification of high limit functionality. The VERSA IC® will allow one-time operation of the limit and then must be returned to normal operation by

turning DIP switch #8 back to the OFF position. Power to the unit must then be cycled off, then on to return to normal operation.

9. Test ignition system safety device:
 - a. Close downstream manual gas valve. See **Figure 68**. Turn power on.
 - b. Close Enable/Disable circuit to call for heat.
 - c. The burner should attempt three trials for ignition for the standard model and then lock out. Single-try ignition modules will try only once and then lock out.
 - d. Open manual gas valve. Reset the ignition control by pressing for one second and then releasing the reset button adjacent the user interface or at the PIM to clear the ignition fault.
10. To restart system, follow lighting instructions in the Operation section.
11. Check to see that the high limit control is set above the design temperature requirements of the system. For multiple zones: Check to make sure the flow is adjusted as required in each zone.
12. Check that the boiler is cycled with the thermostat. Raise the setting on the thermostat to the highest setting and verify that the boiler goes through the normal start-up cycle. Reduce to the lowest setting and verify that the boiler goes off.
13. Observe several operating cycles for proper operation.
14. Set the boiler thermostat to desired temperature.
15. Review all instructions shipped with this boiler with owner or maintenance person, return to envelope and give to owner or place the instructions inside front panel on boiler.

8. OPERATION

Lighting Instructions

1. Before operation, make sure you have read all of the safety information in this manual.
2. Remove front panel.
3. Set the thermostat to the lowest setting.
4. Turn off all electrical power to the appliance.
5. This appliance is equipped with an ignition device which automatically lights the burner. Do not try to light the burner by hand.
6. Turn on main manual gas valve field-installed near gas inlet connection on back of boiler.
7. Turn on all electrical power to the appliance.

8. Set thermostat to desired setting. The appliance will operate. The igniter will activate after the pre-purge time delay (15 seconds). After igniter reaches temperature (30 seconds) the main valve should open for a 4-second trial for ignition. System will try for ignition up to three times (one time on optional single-try ignition module). If flame is not sensed, lockout will commence.
9. If the appliance will not operate, follow the instructions "To Turn Off Gas To Appliance," and call your service technician or gas supplier.
10. Replace front panel.
11. If boiler fails to start, verify the following:
 - a. There are no loose connections or that the service switch is off or in the powered, but disabled position.
 - b. High temperature limit switch (optional) is set above water temperature or manual-reset high limit is not tripped.
 - c. Enable/Disable circuit is closed.
 - d. Gas is on at the meter and the boiler.
 - e. Incoming dynamic gas pressure to the gas valve is NOT less than 4" WC for natural gas or propane gas.

To Turn Off Gas To Appliance

1. Shut off manual gas valve field installed near gas inlet connection on back of boiler.
2. Remove front panel.
3. Move 3-position rocker switch to "OFF" position.
4. Turn off all electrical power to the appliance if service is to be performed.
5. Replace access panel.

Boiler Status Light

The light operation status of the boiler change as follows:

- White [Solid] - IDLE - Unit is powered on
- Blue [Pulsing] - PREPURGE/IGNITION - Call for heat
- Blue [Solid] - MODULATING - Burner is on
- White [Pulsing] - PREPURGE - Call for heat terminated
- Red [Pulsing] - ERROR - Operation error message displayed in touchscreen.

For error details please refer to the VERSA IC® control Manual (241493).

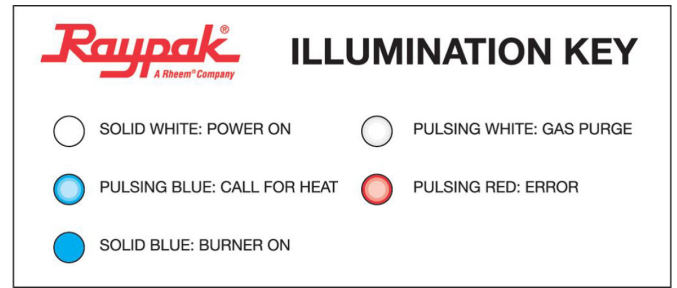

Figure 69. Touchscreen Illumination Key Screen

9. TROUBLESHOOTING

XVersL Error Codes

If any of the sensors detect an abnormal condition or an internal component fails during the operation of the XVersL, the display may show the error. This code may either be the result of a temporary condition in which case the display will revert to its normal readout when the condition is corrected, or it may be the result of a condition that the controller has evaluated as not safe to restart the unit. In this case, the unit control will be locked out, requiring the maintenance person to manually reset the control by pressing and releasing the RESET button.

Error messages are displayed in touchscreen. For additional error details please refer to the VERSA IC® control Manual (241493).

Heater Errors

When an error condition occurs, the touchscreen will display an error message. These error codes and several suggested corrective actions are included in the XVersL Fault Text section on the following page.

Heater Faults

1. When a fault condition occurs, the touchscreen will flash a red light on the PIM and display the error on the user interface. The alarm output will also be activated. Most fault conditions will also cause the boiler pump (if equipped) to run in an attempt to cool the unit.
2. Note the error code, either through the flash code on the PIM and/or from the Boiler menu on the user interface, and reference the explanation of the fault along with troubleshooting steps in the XVersL fault text section.
3. Investigate and correct the cause of the fault.
4. Press and release the RESET key to clear the fault on the user interface and resume operation. Be sure to observe the operation of the unit for a period of time to ensure correct operation and no re-occurrence of fault code(s).

NOTE: It may be necessary to press RESET buttons on the specific safety control (eg. optional adjustable manual-reset high limit, low gas pressure switch, high gas pressure switch, low water cutoff, etc.)

⚠ DANGER: When servicing or replacing components that are in direct contact with the water, be certain that:

- There is no pressure in the boiler. (Pull the release on the relief valve. Do not depend on the pressure gauge reading).
- The boiler water is not hot.
- The electrical power is off.

⚠ WARNING: When servicing or replacing any components of this unit be certain that:

- The gas is off.
- All electrical power is disconnected.

⚠ WARNING: Do not use this appliance if any part has been under water. Improper or dangerous operation may result. Contact a qualified service technician to inspect the boiler and to repair or replace any part of the boiler that has been under water prior to placing the boiler back in operation.

⚠ CAUTION: Wiring errors can cause improper and dangerous operation. Verify proper operation after servicing. See wiring diagram.

⚠ CAUTION: If overheating occurs or the gas supply fails to shut off, do not turn off electrical power to the circulating pump. This may aggravate the problem and increase the likelihood of boiler damage. Instead, shut off the gas supply to the boiler at the gas service valve.

Raymote Troubleshooting

Please refer to the Raymote installation and operation manual (241788).

XVersL Fault Text

Error Display

If there is an active error, then it is displayed in multiple touchscreen views until the error is resolved. For additional error details please refer to the VERSA IC® control Manual (241493).

Error Item	Description and Troubleshooting
OUTLET SEN	Check the outlet water sensor and its wiring
LIMIT SEN	Check the high limit sensor and its wiring
INLET SEN	Check the inlet sensor and its wiring
GAS PRESS	Check PIM wiring
IGNITION	Reset control, push and release RESET button
LIMIT TRIP	Boiler temperature tripped the high limit
FLAME	False flame detected. Shut off gas supply, recycle power
ID CARD	Identity card, check ID card and wiring
IGN CTRL	Internal control fault. Reset power, replace control
DELTA T	Temperature difference between the inlet and outlet exceeded the setpoint. Check water flow
LOW 24VAC	Low 24 VAC power. Check power supply wiring and transformer
BLOW SPEED	Blower speed out of range. Check blower wiring and blower
FLOW ERROR	The unit is not detecting enough flow to allow ignition sequence to take place
UNDER FLOW	The flow reading has drop under minimum requirements to keep the current operation point
FLOW WARNING	Operating conditions do not match current flow reading

Table AB. Error Display

PIM LED Error Code Listing

Active errors detected are indicated by LED lights on the PIM.

Error Mode	LED Flash Code on PIM	Recommended Troubleshooting
Normal Operation	Red LED OFF	
ID Card Fault	Red LED Steady ON, Green Power LED OFF	Check that the proper ID Card is securely connected. Perform a power and system reset.
Internal Control Fault	Red LED Steady ON	Perform a power and system reset. If the fault remains, replace the PIM
N/A	Red LED – 1 Flash	N/A
False Flame Error	Red LED – 2 Flashes	Check for proper gas valve closure. Clean burner and electrodes
Ignition Lockout Fault	Red LED – 3 Flashes	Check the gas supply. Check transformer. Check igniters. Check wiring. Press reset button on PIM/membrane switch. Recycle power
Ignition Proving Current Fault	Red LED – 4 Flashes	Check DSI element. Replace as necessary
Low Voltage Fault	Red LED – 5 Flashes	Check the 24VAC input voltage – the voltage must be above 18.0VAC for proper operation. Replace transformer as necessary
N/A	Red LED – 6 Flashes	N/A
Hi-Limit Fault	Red LED – 7 Flashes	Check for proper water flow. Check hi-limit setting and outlet sensor
Sensor Fault	Red LED – 8 Flashes	Check the VERSA IC [®] for fault identification. Check sensor and wiring
N/A	Red LED – 9 Flashes	Check wiring at J8, pins 1 and 3 for loose or missing jumper
Water Pressure Fault	Red LED – 10 Flashes	Check system piping for leaks. Check water pressure switch (if equipped) and connections. Check wiring on PIM at J1, pins 6 and 7 for loose or missing jumper
Blower Speed Fault	Red LED – 11 Flashes	Verify the tachometer signal and the connections at terminals J10 on the PIM. Confirm power to boiler is at or above minimum required
N/A	Red LED – 12 Flashes	Check wiring on PIM at J1, pins 3 and 4 for loose or missing jumper
Hi-Temperature Delta Fault	Red LED – 13 Flashes	Check pumps operation. Confirm proper water flow across heat exchanger (Delta T)
Ft_bus Communications Fault	Red LED – 14 Flashes	Verify that the VERSA IC [®] is connected and operating properly. Check the cable between the PIM and the VERSA IC [®]
General limit circuit fault	Red LED – 15 Flashes	Check the VERSA IC [®] for fault indication and troubleshooting information

Table AC. PIM LED Error Codes

Sensor Resistance Values

Water Sensor / Outdoor Sensor	
Water Temperature	Resistance (ohms)
32°F (0°C)	32550
41°F (5°C)	25340
50°F (10°C)	19870
59°F (15°C)	15700
68°F (20°C)	12490
77°F (25°C)	10000
86°F (30°C)	8059
95°F (35°C)	6535
104°F (40°C)	5330
113°F (45°C)	4372
122°F (50°C)	3605
131°F (55°C)	2989
140°F (60°C)	2490
149°F (65°C)	2084
158°F (70°C)	1753
167°F (75°C)	1481
176°F (80°C)	1256
185°F (85°C)	1070
194°F (90°C)	915
203°F (95°C)	786
212°F (100°C)	667

Table AD. Approximate Sensor Resistance Values

10. MAINTENANCE

Suggested Minimum Maintenance Schedule

Regular service by a qualified service agency and maintenance must be performed to ensure maximum operating efficiency.

Daily and monthly maintenance as outlined below may be performed by onsite maintenance staff.

Daily

1. Check that the area where the boiler is installed is free from combustible materials, gasoline, and other flammable vapors and liquids.
2. Check for and remove any obstruction to the flow of combustion or ventilation air to boiler.

Monthly

1. Check for piping leaks around pumps, mixing valves, relief valves, and other fittings. If found, repair at once. DO NOT use petroleum-based stop-leak compounds.
2. Visually inspect venting system for proper function, deterioration or leakage.
3. Visually inspect for proper operation of the condensate drain in the venting. If leaks are observed repair at once.
4. Check air vents for leakage.

Yearly (Beginning of each Heating Season)

Schedule annual service by qualified service agency.

1. Visually check top of vent for soot. Call service person to clean. Some sediment at bottom of vent is normal.
2. Visually inspect venting system for proper function, deterioration or leakage. Ensure that condensate drain is inspected and ensure that condensate is being directed to appropriate condensate treatment system or drain, as required by local codes.
3. Check that area is free from combustible materials, gasoline, and other flammable vapors and liquids.
4. Follow pre-start-up check in the Start-up section.
5. Check flame strength signal as noted on display. Remove and visually inspect the direct spark igniter and sensor for damage, cracking or debris build-up.
6. Check operation of safety devices. Refer to manufacturers' instructions.
7. Follow oil-lubricating instructions on pump (if required). Over-oiling will damage pump. Water-lubricated circulators do not need oiling.
8. To avoid potential of severe burn, DO NOT REST HANDS ON OR GRASP PIPES. Use a light touch; return piping will heat up quickly.
9. Check blower and blower motor.
10. Check for piping leaks around pumps, relief valves and other fittings. Repair, if found. DO NOT use petroleum-based stop-leak.

Periodically

1. Check relief valve.
2. Test low water cut-off. (With boiler in pre-purge, depress the low water cut-off test button. Appliance should shutoff and service light should come on. Depress reset button on front of junction box panel to reset).
3. Check and clean strainer in y-strainer or suction diffuser for debris, if equipped.

Preventive Maintenance Schedule

The following procedures are recommended and are good practice for all XVersL installations.

Daily

1. Check gauges, monitors and indicators.
2. Check instrument and equipment settings. See "Post Start-Up Check" on **62**.

Weekly

For low-pressure boilers, test low-water cut-off device.

Monthly

1. Check flue, vent, stack, or outlet dampers.
2. Test blower air pressure. See "Blower Check" on **59**.
3. Test high and low gas pressure interlocks, if equipped. See "Safety Inspection" on **61**.

Semi-Annually

1. Recalibrate all indicating and recording gauges.
2. Check flame failure detection system components.
3. Check firing rate control by checking the manifold pressure. See "Manifold Check" on **60**.
4. Check piping and wiring of all interlocks and shutoff valves.

Annually

1. Test flame failure detection system and pilot turnaround.
2. Test high limit and operating temperature. See "Post Start-Up Check," **62**.
3. Check flame sensor.
4. Check flame signal strength. (Flame signal should be greater than 1 **microampere** as measured at the 2 pins on the bottom of the PIM).
5. Conduct a combustion test at full fire.

NOTE: Technician performing initial start-up must carry a calibrated combustion analyzer to ensure desired combustion levels are achieved.

⚠ WARNING: The unit has been factory tested and pre-certified at the reference gas pressure as shown on the unit decal. If the desired CO₂ and CO values are not achieved at the listed air pressure in Table X within tolerance specified, contact your local Raypak Representative or Raypak factory for direction. Tampering with preset values can lead to poor performance of the unit and result in personal injury, death or property damage.

6. Check emission at minimum fire and record CO and CO₂ reading. See start-up for CO and CO₂ readings. If CO and CO₂ are not within these ranges, stop running the unit and contact your Raypak representative.
7. Check valve coil for 60-cycle hum or buzz. Check for leaks at all valve fittings using a soapy water solution (while boiler is operating). Test other operating parts of all safety shutoff and control valves and increase or decrease settings (depending on the type of control) until the safety circuit opens. Reset to original setting after each device is tested.
8. Perform leakage test on gas valves. See **Figure 68**.
9. Inspect and clean burner using shop air.

CAUTION: Do not clean with water.

10. Drain heat exchanger and inspect the water side visually for build up or debris by removing inlet stub pipe or suction diffuser inspection cover.

As Required

1. Recondition or replace low water cut-off device.
2. Check sediment trap and gas strainers.
3. Check flame failure detection system. See "Post Start-Up Check," **62**.
4. Check igniter. Resistance reading should be 40-75 ohms at 77°F (25°C).
5. Check flame signal strength. (Flame signal should be greater than 1 **microampere** as measured at the 2 pins on the bottom of the PIM).
6. Check firing rate control by checking the manifold pressure. See "Manifold Check" on **60**.
7. Test safety/safety relief valves in accordance with ASME Heater and Pressure Vessel Code Section IV.

Filter Maintenance

- Inspect quarterly. Replace as needed. The recommended interval is once per year.

NOTE: Use Raypak replacement filters:
For models 406L - 606L (10" x 10") kit number 013290F.
For models 726L - 856L (12" x 12") kit number 012553F.

11. ILLUSTRATED PARTS LIST

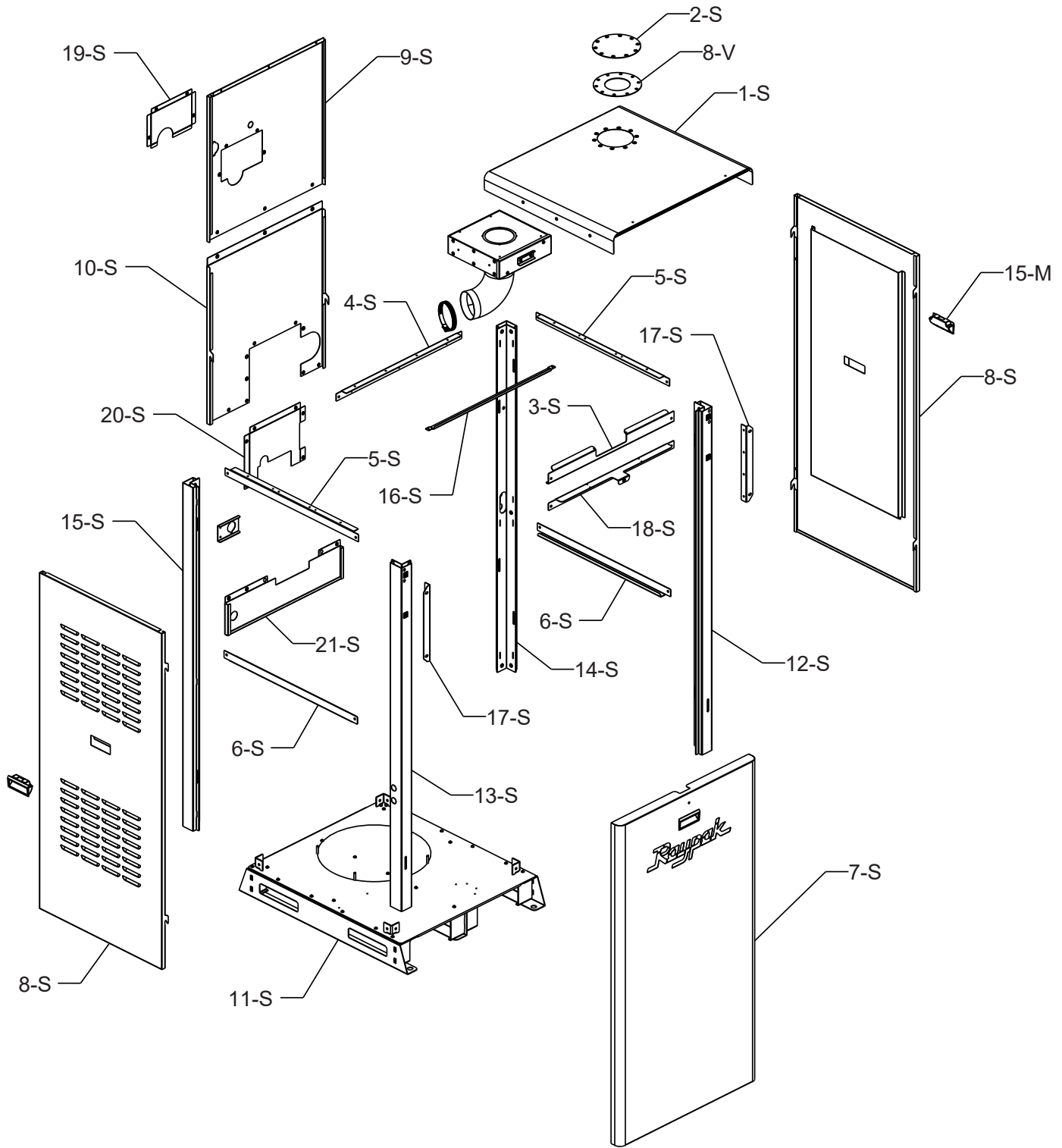

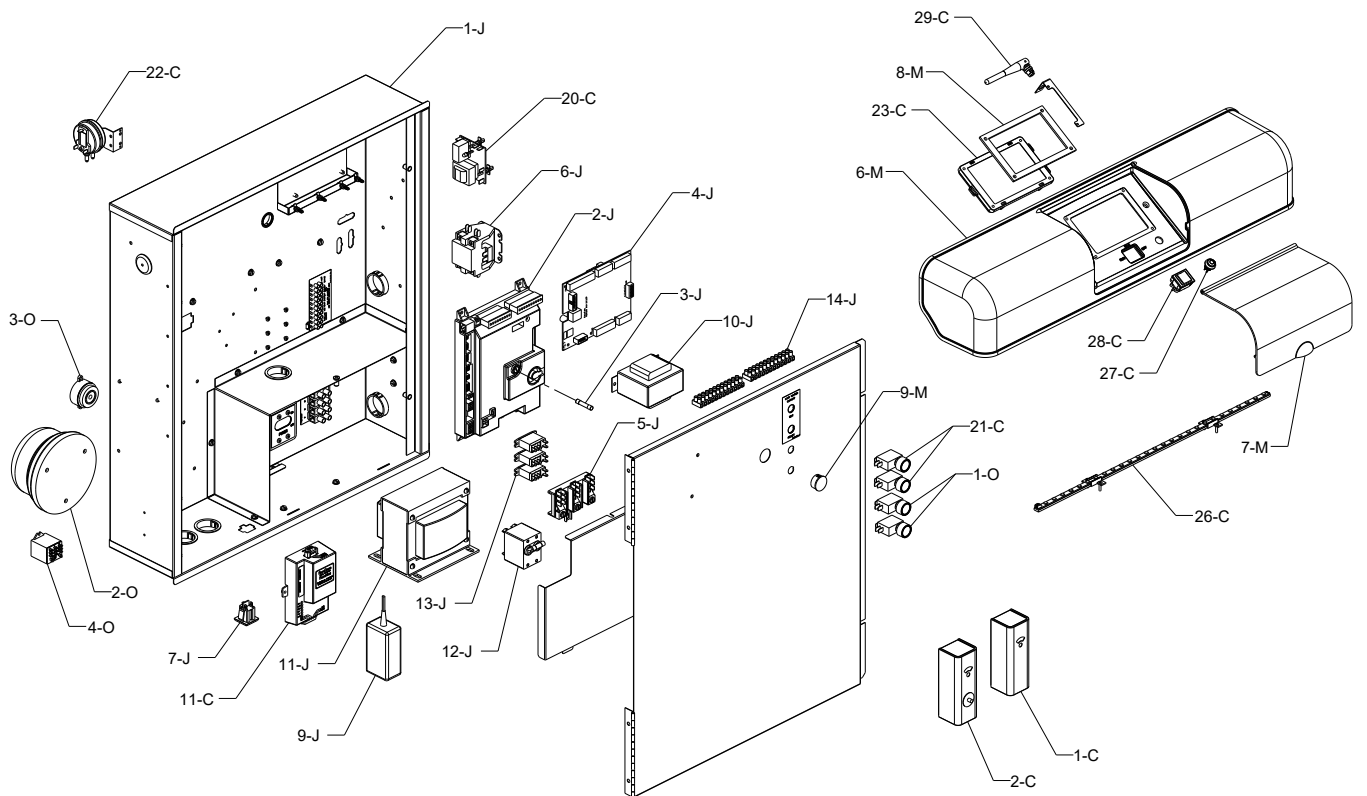
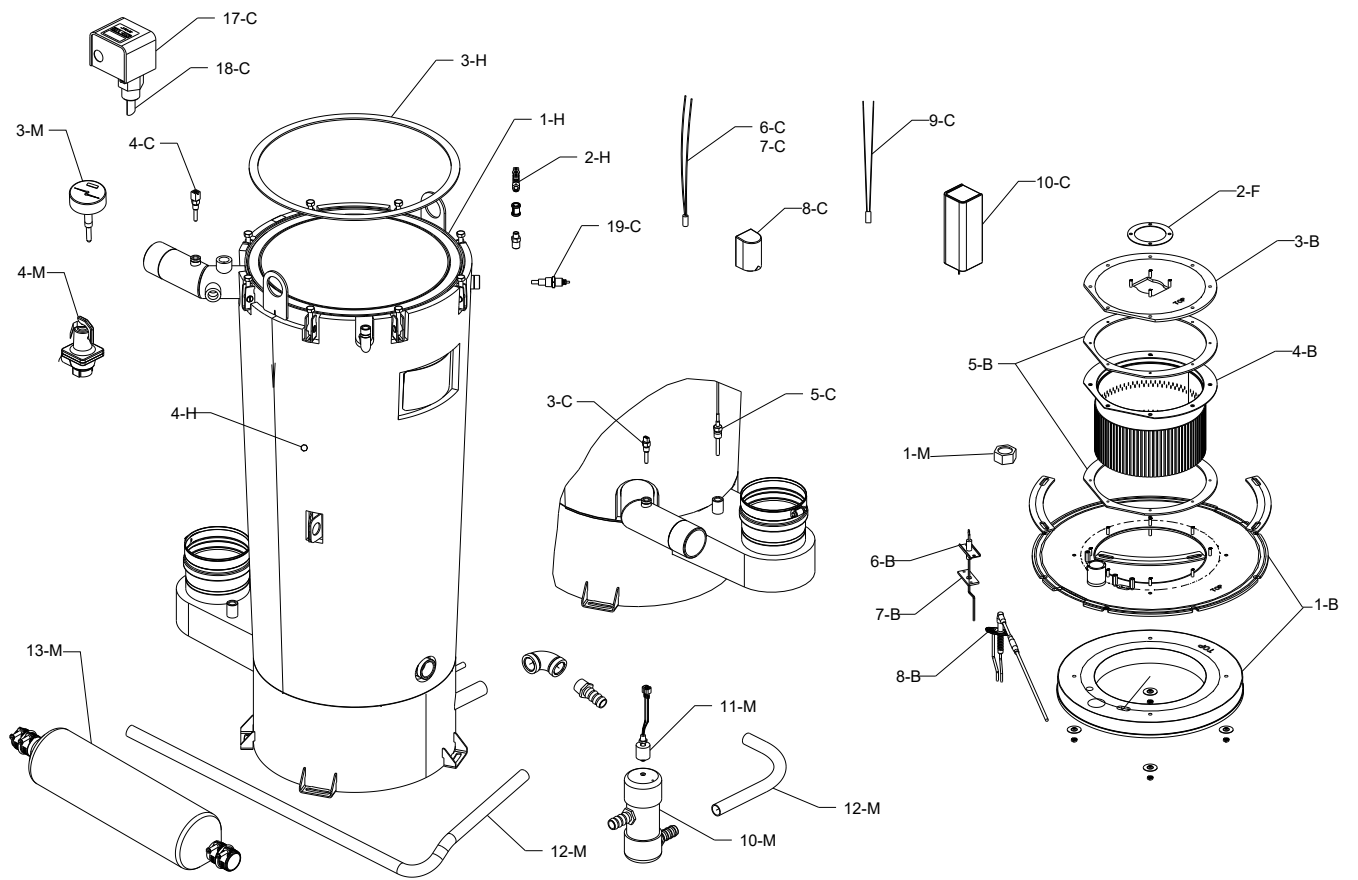

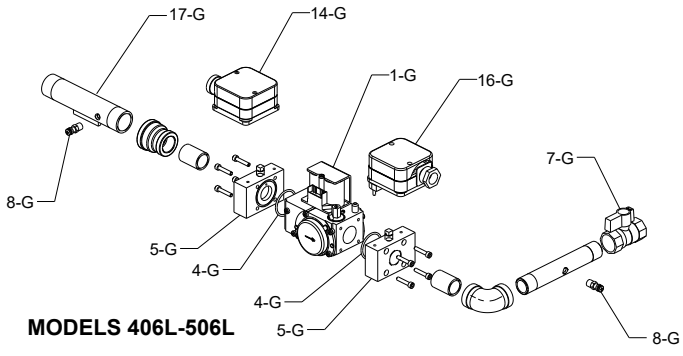

MODELS 406L-506L

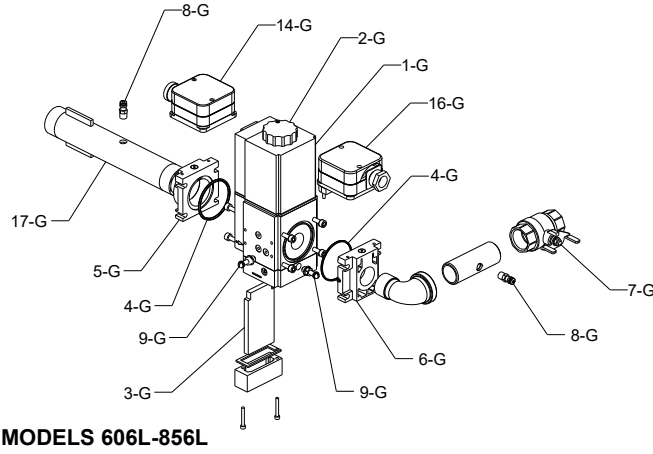
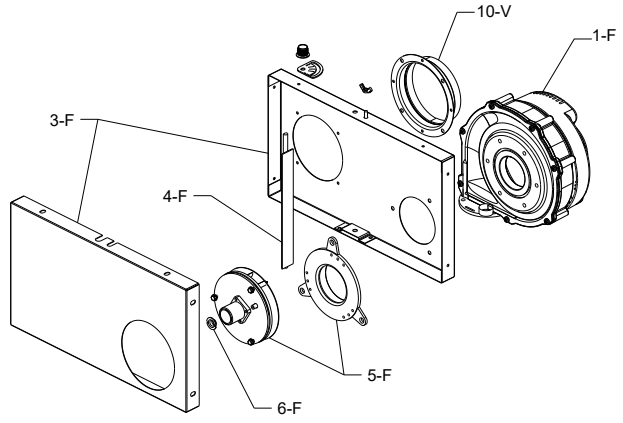

MODELS 606L-856L

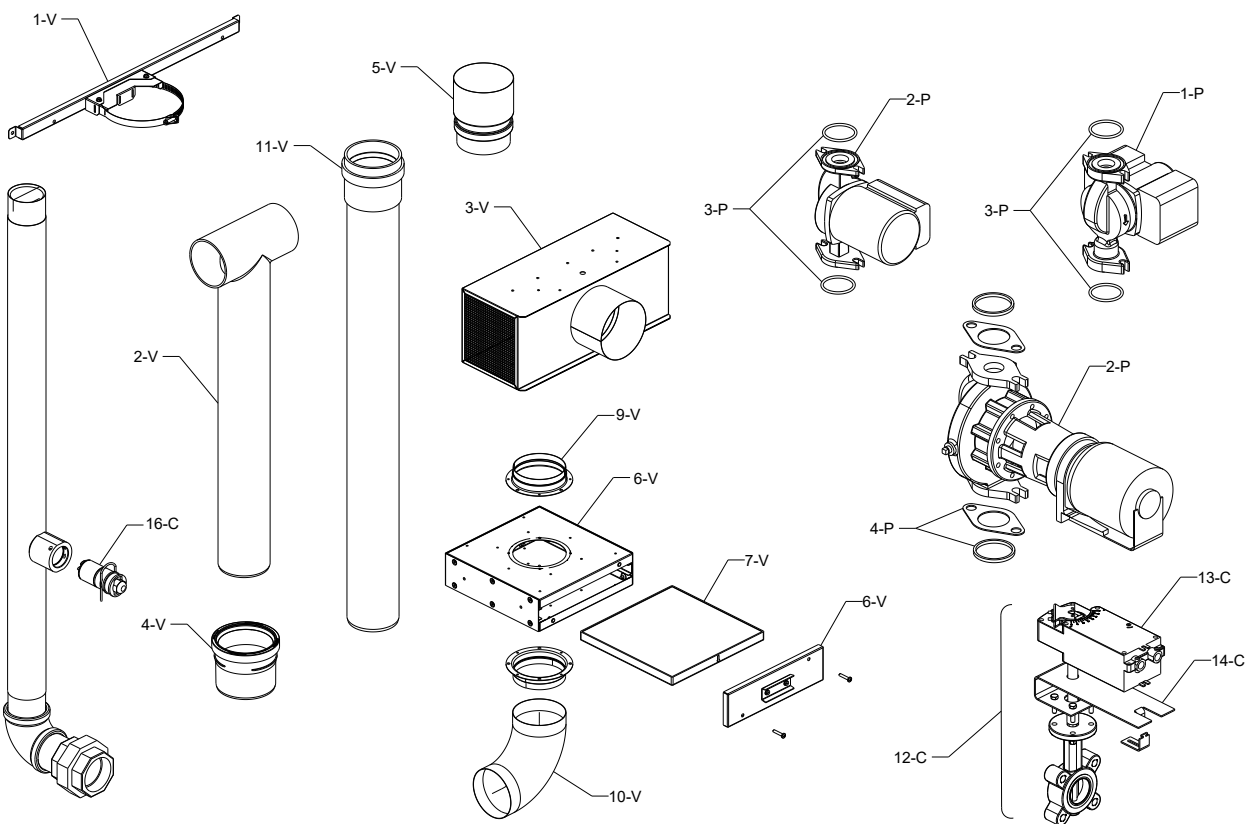
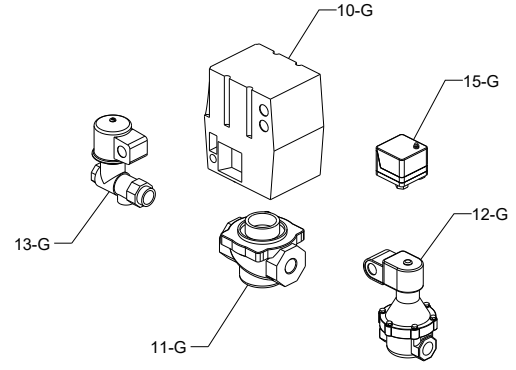

CALL OUT	DESCRIPTION	406L	506L	606L	726L	856L
B	BURNER ASSEMBLY					
1-B	Combustion Chamber Top/Refractory	018916F	018916F	018916F	018917F	018917F
2-B	Refractory Combustion Chamber	N/A	N/A	N/A	N/A	N/A
3-B	Blower Plate (Includes 5-B)	017794F	017795F	017795F	017795F	017796F
4-B	Burner (Includes 5-B)	017797F	017797F	017797F	017798F	017798F
5-B	Burner Gaskets	017799F	017799F	017799F	017799F	017799F
6-B	Flame Sensor Probe (Includes 7-B)	017954F	017954F	017954F	017954F	017954F
7-B	Sensor Gasket	016749F	016749F	016749F	016749F	016749F
8-B	Igniters DSI XVers L (Includes 40" Cable)	017800F	017800F	017800F	017800F	017800F
C	CONTROLS					
1-C	Auto Reset Adjustable High Limit 200F (Optional)	012546F	012546F	012546F	012546F	012546F
2-C	Manual Reset Adjustable High Limit 200F (Optional)	008081F	008081F	008081F	008081F	008081F
3-C	Inlet Sensor (2 Wire)	013175F	013175F	013175F	013175F	013175F
4-C	Outlet Sensor (4 Wire)	013932F	013932F	013932F	013932F	013932F
5-C	Flue Temperature Sensor 10K	016761F	016761F	016761F	016761F	016761F
6-C	System Water Sensor 10K	010787F	010787F	010787F	010787F	010787F
7-C	Indirect DHW Sensor 10K	010787F	010787F	010787F	010787F	010787F
8-C	Sensor Outdoor Air	010786F	010786F	010786F	010786F	010786F
9-C	Sensor Water (Temp Tracker) (Optional)	012187F	012187F	012187F	012187F	012187F
10-C	Indirect Tank Aquastat Control (Optional)	007148F	007148F	007148F	007148F	007148F
11-C	Gateway BACnet Interface Module (Optional)	016617F	016617F	016617F	016617F	016617F
	Gateway LonWorks Interface Module (Optional)	016618F	016618F	016618F	016618F	016618F
12-C	2-Way Motorized Stainless Steel Isolation Valve	017845F	017845F	017845F	017846F	017846F
13-C	Actuator 2-Way Valve	016763F	016763F	016763F	016763F	016763F
14-C	Mounting Bracket Kit	015551F	015551F	015551F	015551F	015551F
16-C	Flow Meter (Optional)	017809F	017809F	017809F	017809F	017809F
17-C	Flow Switch (Optional)	007142F	007142F	007142F	007142F	007142F
18-C	Flow Switch Paddle (Taco)	010026F	010026F	010026F	010026F	010026F
19-C	Remote Sensor (LWCO)	007228F	007228F	007228F	007228F	007228F
20-C	Control PC Board (LWCO)	007157F	007157F	007157F	007157F	007157F
21-C	Test / Reset Switch (LWCO)	005641F	005641F	005641F	005641F	005641F
22-C	Switch Air Pressure (Blocked Vent)	011760F	011760F	011760F	011760F	011760F
23-C	Touchscreen Display (Includes 8-M)	017810F	017810F	017810F	017810F	017810F
24-C	SD Card Programmed (Not Shown)	017811F	017811F	017811F	017811F	017811F
25-C	Lithium Battery 3V (Not Shown)	015888F	015888F	015888F	015888F	015888F
26-C	Indicator strip LED	017812F	017812F	017812F	017812F	017812F
27-C	Display Reset Button	015879F	015879F	015879F	015879F	015879F
28-C	Rocker Switch (3) Position	016795F	016795F	016795F	016795F	016795F
29-C	Wifi Antenna	017198F	017198F	017198F	017198F	017198F
F	FAN / BLOWER					
1-F	Blower Combustion Air (Includes 2-F)	017813F	017814F	017814F	017814F	017815F
2-F	Blower Gasket	018972F	017816F	017816F	017816F	011886F
3-F	Plenum Assembly	017817F	017818F	017819F	017820F	017820F
4-F	Air Shutter	017821F	017821F	017822F	017822F	017822F
5-F	Swirler	017971F	017972F	017870F	017871F	017871F
6-F	Nozzle 9.0mm	013944F	N/A	N/A	N/A	N/A
G	GAS TRAIN					
1-G	Gas Valve Modulating Natural Gas	013942F	013942F	016899F	016899F	016899F
	Gas Valve Modulating Propane Gas	013942F	013942F	016899F	016899F	016899F
2-G	Valve Coil 120V	N/A	N/A	013201F	013201F	013201F
3-G	Inlet Gas Filter	N/A	N/A	012294F	012294F	012294F
4-G	O-Rings (Includes Gas Valve O-Rings)	013203F	013203F	012440F	012440F	012440F
5-G	Adapter Gas Valve 3/4" Inlet (Includes O-Rings)	013204F	013204F	N/A	N/A	N/A
	Adapter Gas Valve 1-1/4" Inlet (Includes O-Rings)	N/A	N/A	011916F	011916F	011916F
6-G	Adapter Gas Valve Outlet 1" w/Shutter (Includes O-Ring)	N/A	N/A	013206F	013206F	013206F
7-G	Valve Gas Ball (WOG)	013208F	013208F	011769F	011769F	011769F
8-G	Bleedle Valve 1/8 MPT	007423F	007423F	007423F	007423F	007423F
9-G	Bleedle Valve G-1/8 BST	015400F	015400F	015400F	015400F	015400F
10-G	Motorized Safety Shut Off Actuator	011908F	011908F	011908F	011908F	011908F
11-G	Gas Valve Body M-1 (Optional)	014014F	014014F	014015F	014015F	014015F
12-G	Solenoid Safety Shut Off Valve	011909F	011909F	011910F	011910F	011910F
13-G	Vent Valve Gas M-15 (Optional)	011913F	011913F	011913F	011913F	011913F
14-G	Switch Low Gas Pressure	011770F	011770F	011770F	011770F	011770F
15-G	Switch Low Gas Pressure	007187F	007187F	007187F	007187F	007187F
16-G	Switch High Gas Pressure	011771F	011771F	011771F	011771F	011771F
17-G	Wrenching Inlet Assembly	017788F	017788F	017789F	017789F	017789F
H	HEAT EXCHANGER					
1-H	Heat Exchanger Stainless Steel	017825F	017826F	017826F	017827F	017828F
2-H	Air Vent Valve	016970F	016970F	016970F	016970F	016970F
3-H	Heat Exchanger gasket	017829F	017829F	017829F	017830F	017830F
4-H	Heat Exchanger Insulation Jacket	017849F	017849F	017849F	017850F	017850F

CALL OUT	DESCRIPTION	406L	506L	606L	726L	856L
J	CONTROL BOX					
1-J	Control Box Complete	N/A	N/A	N/A	N/A	N/A
2-J	PIM (Platform Ignition Module) Multi Try	017218F	017218F	017218F	017218F	017218F
	PIM (Platform Ignition Module) Single Try (Optional)	017219F	017219F	017219F	017219F	017219F
3-J	Fuse 5 Amp (Fast Acting)	013971F	013971F	013971F	013971F	013971F
4-J	PC Board VERSA IC	013935F	013935F	013935F	013935F	013935F
5-J	Terminal Block w/Ground Lug	008523F	008523F	008523F	008523F	008523F
6-J	Blower Contactor DPST 24 VAC	N/A	N/A	N/A	N/A	009860F
7-J	Power Receptacle	016805F	016805F	016805F	016805F	016805F
8-J	Fuse 3/4 Amp (Not Shown)	017853F	017853F	017853F	017853F	017853F
9-J	AC/DC Adapter	011719F	011719F	011719F	011719F	011719F
10-J	Transformer 115/24V 100VA	007494F	007494F	007494F	007494F	007494F
11-J	Transformer 208/120V 650VA	017891F	017891F	017891F	017891F	017891F
12-J	On/Off Circuit Breaker Switch 5.0 Amp	017833F(208V)	017833F	017833F	017833F	N/A
	On/Off Circuit Breaker Switch 7.5 Amp	017834F(120V)	N/A	N/A	N/A	017834F
13-J	Pump Relay SPDT 120 VAC	012126F	012126F	012126F	012126F	012126F
14-J	Terminal Block 12 Space	017857F	017857F	017857F	017857F	017857F
M	MISCELLANEOUS COMPONENTS					
1-M	Sight Glass Combustion Chamber (Units Manufactured prior to 12/21/20)	016796F	016796F	016796F	016796F	016796F
	(Units Manufactured after 12/21/20)	018768F	018768F	018768F	018768F	018768F
2-M	Sight Glass Seal Combustion Chamber (Not Shown)	016797F	016797F	016797F	016797F	016797F
3-M	T & P Gauge 0-90 PSI	007205F	007205F	007205F	007205F	007205F
	T & P Gauge 0-200 PSI	007399F	007399F	007399F	007399F	007399F
4-M	PRV 30 PSI	007470F	007217F	007217F	007218F	007748F
	PRV 45 PSI	007220F	007220F	007346F	007346F	007221F
	PRV 60 PSI	007222F	007222F	007222F	007222F	007222F
	PRV 75 PSI	007223F	007223F	007223F	007223F	007223F
	PRV 150 PSI	007225F	007225F	007225F	007225F	007225F
5-M	RTV Sealant 2.8 oz. (Not Shown)	008924F	008924F	008924F	008924F	008924F
	RTV Sealant 10 oz. (Not Shown)	005755F	005755F	005755F	005755F	005755F
6-M	Control Bezel	017835F	017835F	017835F	017835F	017835F
7-M	Control Bezel Cover	017836F	017836F	017836F	017836F	017836F
8-M	Touchscreen Gasket	017837F	017837F	017837F	017837F	017837F
9-M	Sight Window Plug	008474F	008474F	008474F	008474F	008474F
10-M	Condensate Trap	015473F	015473F	015473F	015473F	015473F
11-M	Condensate Float Switch	013947F	013947F	013947F	013947F	013947F
12-M	Condensate Hose	017851F	017851F	017851F	017851F	017851F
13-M	Condensate Management	017852F	017852F	017852F	017852F	017852F
14-M	Touch-up Paint (Not Shown) Cool Dark Gray	750256	750256	750256	750256	750256
15-M	Flush Mount Handle	016804F	016804F	016804F	016804F	016804F
16-M	Rain Shield Side	018298F	018298F	018298F	018298F	018298F
17-M	Seal Grommet Inlet/Outlet	013234F	013234F	013234F	013235F	013235F
O	OPTIONS					
1-O	Silencer/Reset Switch (Alarm/Buzzer)	005641F	005641F	005641F	005641F	005641F
2-O	Alarm Bell 4" 24V	005643F	005643F	005643F	005643F	005643F
3-O	Alarm Buzzer 24V	005640F	005640F	005640F	005640F	005640F
4-O	Relay 3PDT 24 VAC (Alarm/Buzzer)	014717F	014717F	014717F	014717F	014717F
P	PUMPS*					
1-P	Variable Speed Pump Cast Iron	N/A	N/A	N/A	N/A	018022F
	Variable Speed Pump Stainless Steel	016926F	016926F	016926F	016926F	N/A
2-P	Fixed Speed Pump Cast Iron	N/A	N/A	N/A	N/A	007233F
	Fixed Speed Pump Stainless Steel	016477F	016477F	016477F	016477F	N/A
	Fixed Speed Pump Bronze	N/A	N/A	N/A	N/A	007227F
3-P	Pump Flange Gasket	008747F	008747F	008747F	008747F	N/A
4-P	Pump Flange Gasket (2 Bolt)	N/A	N/A	N/A	N/A	013423F
S	SHEETMETAL/CABINET					
1-S	Jacket Top	017756F	017756F	017756F	017757F	017757F
2-S	Intake Air Cap	017758F	017758F	017758F	017759F	017759F
3-S	Upper Cabinet Support Front	017760F	017760F	017760F	017760F	017760F
4-S	Upper Cabinet Support Rear	017761F	017761F	017761F	017761F	017761F
5-S	Upper Cabinet Supports Left/Right	017762F	017762F	017762F	017762F	017762F
6-S	Side Cabinet Supports Left/Right	017763F	017763F	017763F	017763F	017763F
7-S	Door Assy	017764F	017764F	017764F	017764F	017764F
8-S	Jacket Side Panels Left/Right	017765F	017765F	017765F	017765F	017765F
9-S	Jacket Upper Rear Panel	017766F	17767F	017768F	017769F	017769F
10-S	Jacket Lower Rear Panel	017770F	017770F	017770F	017770F	017770F
11-S	Base Assembly	017771F	017771F	017771F	017772F	017772F
12-S	Vertical Cabinet Support Assy Right/Front	017773F	017773F	017773F	017773F	017773F
13-S	Vertical Cabinet Support Assy Left/Front	017774F	017774F	017774F	017774F	017774F
14-S	Vertical Cabinet Support Assy Right/Rear	017775F	017775F	017775F	017775F	017775F
15-S	Vertical Cabinet Support Assy Left/Rear	017776F	017776F	017776F	017776F	017776F
16-S	Filter Box Support	017779F	017779F	017779F	017779F	017779F
17-S	Control Box Mtg Bracket	017780F	017780F	017780F	017780F	017780F
18-S	Cabinet Door Support	017781F	017781F	017781F	017781F	017781F
19-S	Access Panel Outlet Water	017782F	017782F	017782F	017783F	017783F
20-S	Access Panel Inlet Water	017784F	017784F	017784F	017785F	017785F
21-S	Access Panel Lower Rear	017786F	017786F	017786F	017786F	017786F
22-S	Rain Shield Corner LT/RT	018299F	018299F	018299F	018299F	018299F

* For individual TACO 1600 series pump parts see separate pump parts IPL 9300.100

CALL OUT	DESCRIPTION	406L	506L	606L	726L	856L
V	VENTING					
1-V	Vertical Vent Support	018026	018026	018026	018026	018026
2-V	Outdoor Stack Termination Tee (Polypropylene)	017838F	017838F	017838F	016882F	016882F
3-V	Vent Cap Horizontal Thru-the-Wall for Indoor Units	017839F	017839F	017839F	016720	016720
4-V	Flue Exhaust Adapter for Polypropylene Venting	017840F	017840F	017840F	016855F	016855F
5-V	Flue Exhaust Adapter for PVC to SS	018030	018030	018030	018031	018031
6-V	Filter Box Assembly	017777F	017777F	017777F	017778F	017778F
7-V	Air Filter Media	013290F	013290F	013290F	012553F	012553F
8-V	Intake Air Gasket	017842F	017842F	017842F	017843F	017843F
9-V	Intake Air Adapter	018120F	018120F	018121F	018121F	018121F
10-V	Intake Air Connection Duct	016864F	016864F	016864F	017844F	017844F
11-V	Straight Vent Pipe	017728	017728	017728	016893	016893
12-V	Common Venting On/Off Damper	018339F	018339F	018339F	018340F	018340F
W	WIRING					
1-W	Control Box Wire Harnesses (Not Shown)	017854F	017854F	017854F	017854F	017854F
	Cabinet Wire Harnesses (Not Shown)	017855F	017855F	017855F	017855F	017855F
	Bell & Buzzer Alarm Harness (Not Shown)	017856F	017856F	017856F	017856F	017856F
	VERSA IC Communication Cable (Not Shown)	015556F	015556F	015556F	015556F	015556F
	Boiler ID Harness (Not Shown)	016715F	016715F	016715F	016715F	016715F
	Propane Conversion Kits*					
	Gas Conversions					
	Nat to Pro. DSI Pilot	018303F	018303F	018303F	018303F	018303F

*Gas Conversions to be done only by a qualified agency

12. IMPORTANT INSTRUCTIONS FOR THE COMMONWEALTH OF MASSACHUSETTS

The Commonwealth of Massachusetts requires compliance with regulation 248 CMR 4.00 and 5.00 for installation of through – the – wall vented gas appliances as follows:

(a) For all side wall horizontally vented gas fueled equipment installed in every dwelling, building or structure used in whole or in part for residential purposes, including those owned or operated by the Commonwealth and where the side wall exhaust vent termination is less than seven (7) feet above finished grade in the area of the venting, including but not limited to decks and porches, the following requirements shall be satisfied:

1. INSTALLATION OF CARBON MONOXIDE DETECTORS.

At the time of installation of the side wall horizontal vented gas fueled equipment, the installing plumber or gasfitter shall observe that a hard wired carbon monoxide detector with an alarm and battery back-up is installed on the floor level where the gas equipment is to be installed. In addition, the installing plumber or gasfitter shall observe that a battery operated or hard wired carbon monoxide detector with an alarm is installed on each additional level of the dwelling, building or structure served by the side wall horizontal vented gas fueled equipment. It shall be the responsibility of the property owner to secure the services of qualified licensed professionals for the installation of hard wired carbon monoxide detectors

a. In the event that the side wall horizontally vented gas fueled equipment is installed in a crawl space or an attic, the hard wired carbon monoxide detector with alarm and battery back-up may be installed on the next adjacent floor level.

b. In the event that the requirements of this subdivision can not be met at the time of completion of installation, the owner shall have a period of thirty (30) days to comply with the above requirements; provided, however, that during said thirty (30) day period, a battery operated carbon monoxide detector with an alarm shall be installed.

2. APPROVED CARBON MONOXIDE DETECTORS. Each carbon monoxide detector as required in accordance with the above provisions shall comply with NFPA 720 and be ANSI/UL 2034 listed and IAS certified.

3. SIGNAGE. A metal or plastic identification plate shall be permanently mounted to the exterior of the building at a minimum height of eight (8) feet above grade directly in line with the exhaust vent terminal for the horizontally vented gas fueled heating appliance or equipment. The sign shall read, in print size no less than one-half (1/2) inch in size, "GAS VENT DIRECTLY BELOW. KEEP CLEAR OF ALL OBSTRUCTIONS".

4. INSPECTION. The state or local gas inspector of the side wall horizontally vented gas fueled equipment shall not approve the installation unless, upon inspection, the inspector observes carbon monoxide detectors and signage installed in accordance with the provisions of 248 CMR 5.08(2)(a)1 through 4.

(b) EXEMPTIONS: The following equipment is exempt from 248 CMR 5.08(2)(a)1 through 4:

1. The equipment listed in Chapter 10 entitled "Equipment Not Required To Be Vented" in the most current edition of NFPA 54 as adopted by the Board; and

2. Product Approved side wall horizontally vented gas fueled equipment installed in a room or structure separate from the dwelling, building or structure used in whole or in part for residential purposes.

(c) MANUFACTURER REQUIREMENTS - GAS EQUIPMENT VENTING SYSTEM PROVIDED. When the manufacturer of Product Approved side wall horizontally vented gas equipment provides a venting system design or venting system components with the equipment, the instructions provided by the manufacturer for installation of the equipment and the venting system shall include:

1. Detailed instructions for the installation of the venting system design or the venting system components; and

2. A complete parts list for the venting system design or venting system.

(d) MANUFACTURER REQUIREMENTS - GAS EQUIPMENT VENTING SYSTEM NOT PROVIDED. When the manufacturer of a Product Approved side wall horizontally vented gas fueled equipment does not provide the parts for venting the flue gases, but identifies "special venting systems", the following requirements shall be satisfied by the manufacturer:

1. The referenced "special venting system" instructions shall be included with the appliance or equipment installation instructions; and

2. The "special venting systems" shall be Product Approved by the Board, and the instructions for that system shall include a parts list and detailed installation instructions.

(e) A copy of all installation instructions for all Product Approved side wall horizontally vented gas fueled equipment, all venting instructions, all parts lists for venting instructions, and/or all venting design instructions shall remain with the appliance or equipment at the completion of the installation.

GAS PRESSURE SUPERVISION

The Commonwealth of Massachusetts requires listed high and low gas pressure switches (manual-reset) for any model with a maximum firing input greater than 1,000,000 Btu/Hr in accordance with 248 CMR 7.04(11)(d).

A gas pressure regulator (field supplied) is required in the gas train ahead of the boiler, for boilers having input rates greater than 1,000,000 Btu/Hr, in accordance with 248 CMR 7.04 Figure 3B requirements.

START-UP CHECKLIST FOR XVERS L BOILERS

This start-up checklist is to be completely filled out by the service technician starting up the XVersL Boiler for the first time. All information may be used for warranty purposes and to ensure that the installation is correct. Additionally this form will be used to record all equipment operation functions and required settings.

GAS SUPPLY DATA

Regulator Model & Size _____ / _____ CFH
 Gas Line Size (in room) _____ In. NPT
 Length of Gas Line _____ Eq Ft
 Low Gas Pressure Setting _____ In. WC
 High Gas Pressure Setting _____ In. WC
 Gas Shutoff Valve Type _____
 (Ball, Lube cock)
 Port _____ Std _____ Full

VISUAL INSPECTION OF COMPONENTS

Verify inspection was done and condition of components are in good working order with a "yes"

Wiring Harness _____ Y/N
 Burner (flame) _____ Y/N
 Refractory (Visual) _____ Y/N
 Remote flame sense _____ Y/N
 Covers in place for outdoor _____ Y/N

VENTING

Vent Size: _____ Stack Height: _____
 Vent Material: _____ sketch vent on reverse side ***
 Vent Termination Type: _____
 Combustion Air Openings: Low _____ in²
 Ventilation Air High _____ in²

CLEARANCES

Front Clearance _____ In.
 Right Side Clearance _____ In.
 Left Side Clearance _____ In.
 Rear Clearance _____ In.
 Overhead Clearance _____ In.

ELECTRICAL

Voltage Supply (VAC) _____ No Load _____
 _____ Load _____
 Voltage -24 VAC _____ VAC
 Voltage Com to Ground _____ VAC
 Hot Surface Igniter _____ Ohms
 Auto High Limit Setting _____ deg F
 Manual Reset High-Limit Setting _____ deg F
 Operating Control Setting _____ deg F

Sketch plumbing on reverse side

WATER SUPPLY

Flow Rate in GPM or Delta T _____ If Avail
 Measure flow rate at full fire
 Pump Purge setting _____ Minutes
 Low Water Cutoff _____ Test
 Plumbing Size _____
 Pump Size: _____ (Boiler) Pump HP: _____
 Impeller trim _____ Pump Model _____
 Louvers _____ Screens _____

RAYMOTE (If equipped)

Wi-Fi signal available in boiler room _____
 Boiler provisioned with valid WiFi credentials _____
 Wi-Fi signal strength (RSSI > -80) _____

EMISSIONS SETTINGS AND TEST INFORMATION

	(AT FULL FIRE)	(AT MIN. FIRE)
Blower Suction Pressure	_____ In. WC	_____ In. WC
Supply Gas Pressure	_____ In. WC	_____ In. WC
Verify stable pressure static and dynamic condition		
Manifold Gas Pressure	_____ In. WC	_____ In. WC

Nominal Factory Recommended Settings

See manual or card tag
 See manual or card tag
 See manual or card tag

The following measurements must be obtained with a Combustion Analyzer.

O ₂	_____ %	_____ %	See manual
CO	_____ PPM	_____ PPM	Less than 100 PPM
CO ₂	_____ %	_____ %	See manual

Model Number: _____

Serial Number: _____

*** Note: draw venting with details, such as extractors, barometric dampers, blast dampers or draft inducers

Site Elevation Above Sea Level _____ Ft.

Job Name _____
 Address _____
 Physical Location of Boiler: Indoors _____; Outdoors _____; Ground Level _____; Roof _____; Below Grade _____
 Mechanical Contractor / Installer _____
 Date and Time of Start-up _____ Print Name and Signature of Start-up Technician _____

Information must be faxed to: (805) 278-5496 in order to ensure warranty consideration Attn: Service Manager

LIMITED WARRANTY XVERSL - TYPE H

Models: 406L - 856L

SCOPE

Raypak, Inc. ("Raypak") warrants to the original owner that all parts of this heater which are actually manufactured by Raypak will be free from failure under normal use and service for the specified warranty periods and subject to the conditions set forth in this Warranty. Labor charges and other costs for parts removal or reinstallation, shipping and transportation are not covered by this Warranty but are the owner's responsibility.

EFFECTIVE DATE

The Effective Date of this Limited Warranty is the date of original installation if properly documented; if you are not able to provide documentary proof of the date of original installation, the Effective Date will be the date of manufacture plus 180 days.

HEAT EXCHANGER WARRANTY PERIODS

Space Heating (Closed Loop System ONLY) Ten (10) years from date of heater installation. Thermal Shock Warranty

Twenty five (25) years from date of heater installation against "Thermal Shock"; excluded, however, if caused by heater operation at large changes exceeding 150°F (66°C) between the water temperature at intake and heater temperature, or operating at heater temperatures exceeding 200°F (96°C).

ANY OTHER PART MANUFACTURED BY RAYPAK

One (1) year warranty from date of heater installation, or eighteen (18) months from date of factory shipment based on Raypak's records, whichever comes first.

SATISFACTORY PROOF OF INSTALLATION DATE, SUCH AS INSTALLER INVOICE, IS REQUIRED. THIS WARRANTY WILL BE VOID IF THE HEATER RATING PLATE IS ALTERED OR REMOVED.

ADDITIONAL WARRANTY EXCLUSIONS

This warranty does **NOT** cover failures or malfunctions resulting from:

1. Failure to properly install, operate or maintain the heater in accordance with our printed instructions provided;
2. Abuse, alteration, accident, fire, flood and the like;
3. Sediment or lime build-up, freezing, or other conditions causing inadequate water circulation;
4. High velocity flow exceeding heater design rates;
5. Failure of connected system devices, such as pump or controller;
6. Use of non-factory authorized accessories or other components in conjunction with the heater system;
7. Failing to eliminate air from, or replenish water in, the connected water system;
8. Chemical contamination of combustion air or use of chemical additives to water.

PARTS REPLACEMENT

Under this Warranty, Raypak will furnish a replacement for any failed part. The failed part must first be returned to Raypak if requested, with transportation charges prepaid, and all applicable warranty conditions found satisfied. The replacement part will be warranted for only the unexpired portion of the original warranty. Raypak makes no warranty whatsoever on parts not manufactured by it, but Raypak will apply any such warranty as may be provided to it by the parts manufacturer.

HOW TO MAKE A WARRANTY CLAIM

Promptly notify the original installer, supplying the model and serial numbers of the unit, date of installation and description of the problem. The installer must then notify their Raypak distributor for instructions regarding the claim. If either is not available, contact Service Manager, Raypak, Inc., 2151 Eastman Avenue, Oxnard, CA 93030 or call (805) 278-5300. In all cases, proper authorization must first be received from Raypak before replacement of any part.

EXCLUSIVE WARRANTY-LIMITATION OF LIABILITY

The Limited Warranty is the only warranty for this product and its component parts given by Raypak. No one is authorized to make any other warranties on Raypak’s behalf. **ANY IMPLIED WARRANTIES, INCLUDING MERCHANTABILITY OR FITNESS FOR A PARTICULAR PURPOSE, SHALL NOT EXTEND BEYOND THE APPLICABLE WARRANTY PERIODS SPECIFIED IN THIS LIMITED WARRANTY. RAYPAK’S SOLE LIABILITY WITH RESPECT TO ANY DEFECT SHALL BE AS SET FORTH IN THIS LIMITED WARRANTY. IT IS AGREED THAT RAYPAK SHALL HAVE NO LIABILITY WHETHER UNDER THIS LIMITED WARRANTY OR IN CONTRACT, TORT OR NEGLIGENCE OR OTHERWISE FOR CLAIMS FOR SPECIAL, INCIDENTAL OR CONSEQUENTIAL DAMAGES (INCLUDING NO LIABILITY FOR DAMAGE FROM WATER LEAKAGE) WHICH ARE EXPRESSLY EXCLUDED, NOTWITHSTANDING ANY FAILURE OF ESSENTIAL PURPOSE OF ANY LIMITED REMEDY.** Some states do not allow limitations on how long an implied warranty lasts, or for the exclusion of incidental or consequential damages, so the above limitation or exclusion may not apply to you.

THIS LIMITED WARRANTY GIVES YOU SPECIFIC LEGAL RIGHTS, AND YOU MAY ALSO HAVE OTHER RIGHTS WHICH VARY FROM STATE TO STATE.

We suggest you immediately record the model and serial number and date of original installation and retain this Limited Warranty Certificate along with your original proof of purchase and date of installation/start-up in the event warranty service is needed.

DO NOT RETURN THIS DOCUMENT TO RAYPAK. KEEP IT WITH YOUR HEATER OR BUSINESS RECORDS.

Name of Owner	Name of Installer
Owners Address	Installers Address
Date of Heater Installation	Telephone Number of Installer
Model Number of Your Heater	Serial Number of Your Heater

RAYPAK, INC., 2151 Eastman Avenue, Oxnard, CA 93030 • (805) 278-5300 FAX (800) 872-9725 www.raypak.com



www.raypak.com

Raypak, Inc., 2151 Eastman Avenue, Oxnard, CA 93030 (805) 278-5300 Fax (805) 278-5468
Litho in U.S.A.