

Job: _____
 Engineer: _____
 Contractor: _____
 Prepared By: _____ Date: _____
 Model: _____ Indoor/Outdoor: _____ MBTUH Input: _____

Hi Delta[®] - Type WH

Water Heaters
 Models 992B-2342B

- 100% Factory Fire Tested**
- Efficiency: 85%**
- Maximum Outlet Temperature: 210°F**
- Minimum Non-Condensing Inlet Temperature: 105°F**
- Thermal Shock Proof Heat Exchanger**
- Limited Twenty-Year Thermal Shock Warranty**
- Limited Five-Year Heat Exchanger Warranty**
- Full Safety Diagnostics with Fault History**
- PolyTuf Powder Coated Cabinet**
- No Combustible Floor Shield Required**
- Fan-Assisted**
- Patented Burner Security Blanket**

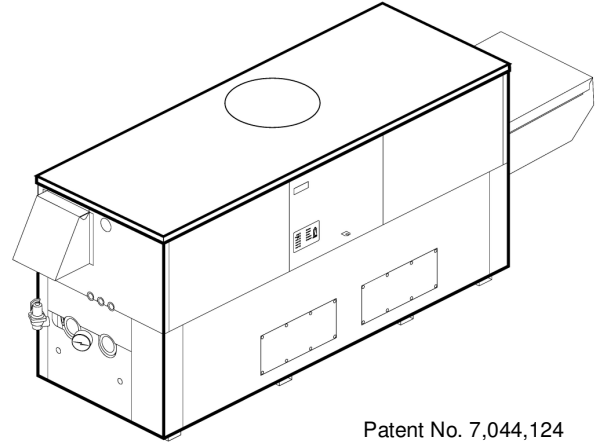

Patent No. 7,044,124



Proudly Assembled in the USA

Heat Exchanger

- HLW Stamp
- Headers
 - Brass – Standard
 - Glass-Lined Cast Iron – Option A-2
- ASME Inspected and Stamped 160 PSIG Working Pressure
- National Board Approved
- Fin Tubing
 - Copper – Standard
 - Cupro Nickel – Option A-3
- ASME Steel Tube Sheet
- Silicone High Temp. O-Rings
- ASME Pressure Relief Valve
 - 125 PSIG – Standard
 - _____ PSIG – Optional
- Temperature and Pressure Gauge
- Water Connections
 - Left – Standard
 - Right – Option A-6

Controls

- 120V, 60Hz, 1Ø Power Supply
- 120/24V 60Hz Transformer
- 100% Shut-Off/Lockout
- Hot Surface Ignition
- Remote Flame Sensor
- High Limit Control, Manual Reset
- On/Off Power Switch
- Manual Shut-Off, Front-Mounted
- Flow Switch
- Blocked Vent Pressure Switch
- Combustion Air Proving Switches
- Economaster Pump Time Delay
- Enable/Disable
- Diagnostics Panel with LCD Display
2 Lines, 20 Characters

Gas Train

- Manual Gas Shut-Off Valve(s)
- Combo Valve(s)
- Firing Mode
 - 3-Stage: Model 992B
 - 4-Stage: Models 1262B-2342B
- Fuel
 - Natural Gas
 - Propane Gas
 - 4" WC Gas Supply Pressure G-20
- Design Certified - ANSI Z21.10.3/CSA 4.3

Construction

- Indoor/Outdoor Construction
- Enclosed Front Controls
- CSA Low Lead Certified ≤ .25% Lead

Venting

- Vent Location
 - Top – Standard
 - Rear – Option D-14
- Vent Termination Cap
 - Outdoor D-11
 - Indoor, Horizontal D-15
 - Indoor, Vertical (by others)
- Combustion Air
 - In-Line Filter Kit (TruSeal only) D-17
 - Air Intake Elbow D-16
- Extractor – Optional
 - By others
 - Not required

Burner

- Ultra-Low NOx: Less than 20 PPM

Temperature Controls

- B-2 Tankstat, Single-Stage (100-200°F)
- B-3 Tankstat, 2-Stage (100-200°F)
- B-21 TempTracker Digital Controller, 4-Stage
- B-__ TempTracker Mod+ (loose) up to 16
- B-60 Stage Interface

Options

- C-6 Ignition Module, Manual Reset
- D-21 TruSeal[®] Direct Vent
- F-10 Low Water Cut-Off, Remote Probe
- I-1 High Limit Control, Auto Reset
- P-__ Pump: _____ HP, 120V, 1Ø, 60Hz
Water Hardness: _____ GPG
 - Bronze
 - Mounted Loose
 - Front Rear
- P-__ Cold Water Run (See 1000.19)
- S-2 High Gas Pressure Switch, Manual
- X-1 SureRack[™] Kit
- X-2 SureRack Add-on

Regulatory Agency Requirements

- _____



Raypak[®]
 A Rheem[®] Company

Hi Delta – Type WH Models 992B-2342B

Model _____

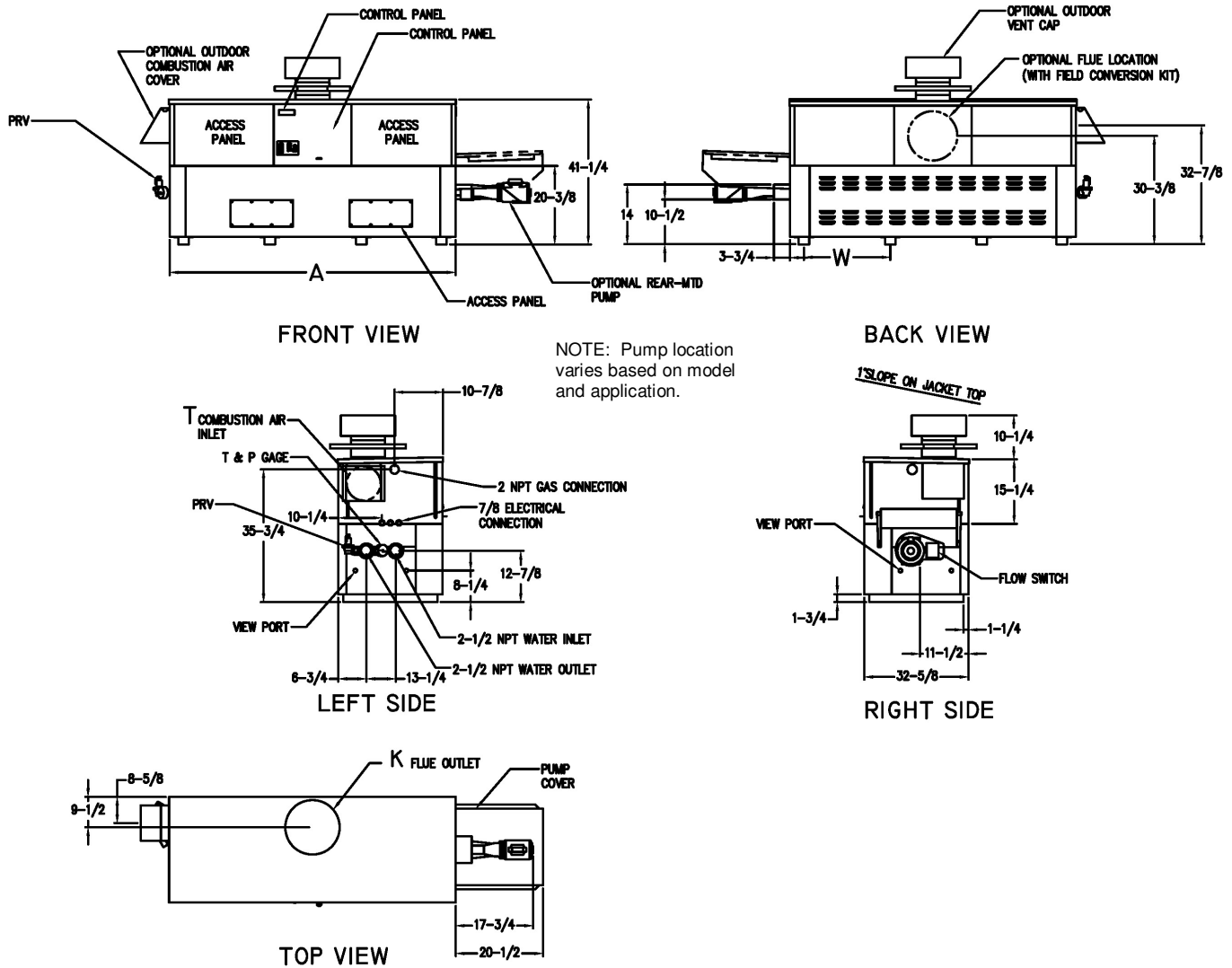

SPECIFICATIONS

Model	MBTUH Input	MBTUH Output	Firing Stages	A Width	H NPT	K	T	W	Amp. Draw*	Approx. Shipping Wt. (Lbs.)
992B	990	842	3	57-1/8	2-1/2	10	10	16-13/16	<12	900
1262B	1260	1071	4	68-1/2	2-1/2	12	10	20-9/16	<12	1010
1532B	1530	1301	4	79-7/8	2-1/2	12	10	24-3/8	<12	1225
1802B	1800	1530	4	91-1/8	2-1/2	14	10	28-1/8	<12	1350
2002B	1999	1699	4	102-1/2	2-1/2	14	10	31-15/16	<12	1450
2072B	2070	1760	4	102-1/2	2-1/2	14	10	31-15/16	<12	1450
2342B	2340	1989	4	113-7/8	2-1/2	16	10	35-11/16	<12	1520

Dimensions are in inches.

* Without pump

RECOVERY RATES (GPH)

Model	Temperature Rise in °F								
	20°	30°	40°	50°	60°	70°	80°	90°	100°
992B	5100	3400	2550	2040	1700	1457	1275	1133	1020
1262B	6491	4327	3245	2596	2164	1855	1623	1442	1298
1532B	7882	5255	3941	3153	2627	2252	1970	1752	1576
1802B	9273	6182	4636	3709	3091	2649	2318	2061	1855
2002B	10298	6865	5149	4119	3433	2942	2574	2288	2060
2072B	10664	7109	5332	4265	3555	3047	2666	2370	2133
2342B	12055	8036	6027	4822	4018	3444	3014	2679	2411

NOTES: 1. Rates shown are for natural or propane gas, and elevations up to 5,000 feet. For installation above 5,000 feet, please contact manufacturer.
2. Required natural gas pressure is 7 - 10.5" WC. Required propane gas pressure is 11 - 13" WC.

Raypak, Inc. ▪ 2151 Eastman Avenue, Oxnard, CA 93030 ▪ (805) 278-5300 ▪ Fax (800) 872-9725 ▪ www.raypak.com