

HEAT PUMPS

Equipped with the Award Winning **Comfort Control System™**



- Increased Reliability
- On-Board Diagnostics
- Fault Recall
- *Active Protection™*

RUUD ULTRA Series

UPNL- JEZ **R-410A**

13 SEER Models
Nominal Sizes 2 to 5 Tons
[7.03 kW] to [17.6 kW]

Six Models

Cooling Capacities
23,200 to 60,500 BTU/HR
[6.80 kW] to [17.73 kW]



The Ruud *Ultra Series™* UPNL- JEZ Heat Pump Outdoor units can provide year-round heating and cooling comfort for residential, multi-family and light commercial applications. They are designed to operate with Ruud indoor units with cooling and heating capacities certified under the AHRI Certification program.

The following additional features, plus its energy-saving characteristics, make the UPNL- JEZ Heat Pump outdoor unit an excellent choice for new construction or upgrading your present system.

The Ruud *Ultra Series™* UPNL- JEZ Heat Pumps are the result of an ongoing development program for improved efficiencies.

- The *Comfort Control System™* provides on-board diagnostics and fault history for heat pumps with single-phase compressors by detecting system and electrical problems without adding sensors. It can also communicate "fault codes" to enabled "L terminal" thermostats. The integrated diagnostics with *Active Protection* prevents compressor operation when potentially harmful conditions are detected.
- 7-Segment LED Display is exclusive only to Ruud products. The information-display quickly and accurately shows technicians the source of malfunctions.
- Features a five-year conditional unit replacement warranty when properly installed with a new Ruud Air Handler OR Ruud Indoor Coil with a Ruud Gas Furnace.
- Compressor sound blanket is standard to provide quiet operation.
- Attractive, louvered wrap around jacket protects coil from weather extremes and yard hazards. Top grille is steel reinforced for extra strength. Cabinet is powder painted for all weather protection.
- Four sided outdoor coil design allows compressor operation with access panel removed.
- Air is discharged upward away from bushes and shrubs. The discharge pattern of the top grille provides minimum air restriction, resulting in quiet fan operation.
- Combination Grille/Motor Mount secures the fan motor to the underside of the discharge grille.
- Removable top grille provides access to the outdoor fan motor and outdoor coil.
- Compressor compartment offers additional protection from the elements and reduces operating noise.
- Single speed, 8-pole fan motor is designed for quieter, energy-saving operation.
- Non-cycling reversing valve and demand defrost.
- All models meet or exceed a 1000-hour salt spray test per ASTM B117 Standard Practice for Operating Salt Spray Testing Apparatus.

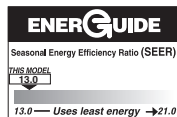

(IN CERTAIN MATCHED SYSTEMS)

"Proper sizing and installation of equipment is critical to achieve optimal performance. Split system air conditioners and heat pumps must be matched with appropriate coil components to meet ENERGY STAR criteria. Ask your Contractor for details or visit www.energystar.gov."

FEATURES & BENEFITS OF THE *COMFORT CONTROL SYSTEM*™

- The Ruud exclusive 7-Segment LED Display easily shows system operating status codes and diagnostic codes.

- A Sealed Switch replaces the standard



contactor and features optical control and latching mechanism. The sealed switch prevents infiltration of insects and dust. A minimal switching arc, by the optical control, offers greater reliability. The latching mechanism consumes less power while reducing chatter.



- The Status Indication and System Diagnostics feature thermostat communication capability, built-in diagnostics, high & low voltage monitoring and high & low pressure switch monitoring. The thermostat communication capability alerts the homeowner to any necessary service requirements. Faster, more accurate service is provided by the built-in diagnostics, by providing the HVAC professional with dependable information. With the high and low voltage monitoring feature, the control provides alerts for out-of-range conditions. In addition, high and low pressure-switch monitoring prevents the system from operating outside of its normal parameters.



- The fault recall feature will allow for the last six fault-codes to be displayed, and will retain these codes even if power failure occurs.
- Built-in short-cycle protection allows the compressor to restart easily without oil removal.
- A 30-second minimum run-time for every compressor call enables oil to return to the compressor.
- *Active Protection* monitors the system to prevent nuisance lockouts and prevents compressor operation when potentially harmful conditions are detected.
- The compressor and fan are controlled independently, which reduces the starting load and light dimming.
- A manual push-button is offered to operate the compressor and fan for 5 seconds to allow for an operation check.
- In order to save time and money, replacement automotive fuses can be utilized instead of replacing the entire control board.

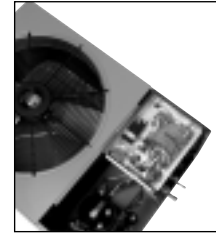

STANDARD FEATURES

UPNL- JEZ Heat Pump Outdoor Units

1. Scroll compressor is hermetically sealed and incorporates internal high temperature motor overload protection, and durable insulation on the motor windings. It is externally mounted on rubber grommets to reduce vibration and noise.
2. **Enhanced Compressor Protection**—Features an **enhanced defrost control, auto-reset high pressure control, and auto-reset low pressure control** to provide compressor protection under abnormally high head pressure conditions (outdoor fan failure, restriction, dirty coil, etc.) or abnormally low suction pressure conditions (restrictions, TEV failure, loss of charge, indoor blower failure, etc.) while eliminating nuisance tripping sometimes experienced with conventional control systems.
3. Compressors have an internal pressure relief assembly to protect against excessive pressure differential.
4. All refrigerant connections are on the exterior of the unit, located close to the ground for neat appearing installations.
5. Cabinet is constructed of powder painted galvanized steel. The full wrap-around louvered grille protects the coil from damage.
6. Enhanced compressor sound blanket is standard.
7. **Demand Defrost Control**—Provides complete defrost when defrost is required.
8. **Non-Cycling Reversing Valve**—Eliminates discharge noises on each heating cycle.
9. **Hot Gas Muffler**—Reduces noise in heating cycle.
10. **Bi-Directional Filter Drier**—Standard on UPNL- JEZ models (shipped – not installed).
11. **Service valves** are standard on all models.
12. **Refrigerant Metering**—TEV accurately meters refrigerant into indoor and outdoor coils.
13. Copper tube—aluminum fin coils are used on all models.
14. The control box is located in the top corner of the cabinet providing for easy access through a service panel.
15. Service valves are standard on all models.
16. Field connections for power and control wiring are kept separate.
17. Every unit is factory charged and run-tested.
18. Separate compressor compartment for easy service access.
19. Drawn, painted basepan for extra corrosion resistance and sound reduction.
20. The **UPNL- JEZ** has a 10 year limited compressor warranty, plus a 5 year conditional unit replacement warranty. See General Terms of Limited Warranty for more details.
21. **Hard Start Kits**—Standard on all JEZ models.
22. Control Box Cover.

Problem-Solving Accuracy

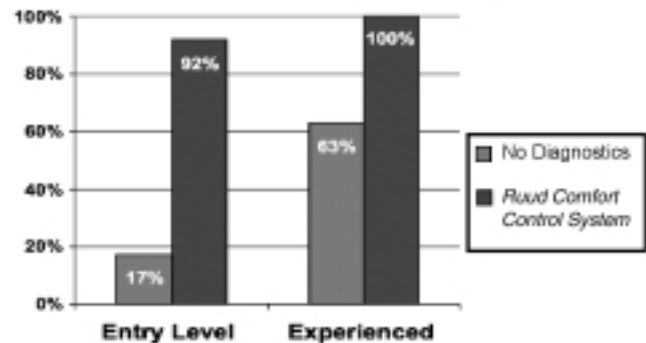

SCROLL® COMPRESSOR

The scroll compressor is the key to efficiency for this Ruud model. It's the latest in high-efficiency compressor technology. The advanced scroll compressor offers low noise and vibration characteristics and features tolerance to liquid refrigerant and system contamination. The scroll compressor also has low start torque, eliminating start problems in the field. And its unique design enables the UPNL- JEZ Heat Pump to perform efficiently, quietly and dependably.

Model Number Identification

<u>U</u>	<u>P</u>	<u>N</u>	<u>L</u>	—	<u>024</u>		<u>J</u>		<u>E</u>		<u>Z</u>
RUUD	REMOTE HEAT PUMP	N = 13 SEER	DESIGN SERIES		COOLING CAPACITY		ELECTRICAL DESIGNATION		VARIATIONS		COOLING CONNECTION FITTING
			L = R-410A		024 = 24,000 BTU/HR [7.03 kW] 031 = 30,000 BTU/HR [8.79 kW] 036/037 = 36,000 BTU/HR [10.55 kW] 043 = 42,000 BTU/HR [12.31 kW] 049 = 48,000 BTU/HR [14.07 kW] 060 = 60,000 BTU/HR [17.58 kW]		J = 208/230V-1-60		E = EQUIPPED WITH THE <i>COMFORT CONTROL SYSTEM™</i>		Z = SWEAT W/SCROLL

[] Designates Metric Conversions

Field Installed Accessories

- **Low Ambient Control**—Allows low temperature operation in the cooling cycle down to 0°F [-17.8°C] outdoor temperature. It is recommended that this control be installed in units to be operated for cooling at outdoor ambient temperatures under 70°F [21°C]. (Model No. RXAD-A08)
- **Thermostats**
 - **Compressor Crankcase Heater**—Available through PROSTOCK®.
 - **Thermostats and Subbases**—Available through PROSTOCK®.
 - **Blower Time Delay Control**—RXMD-C04.
 - **Fossil Fuel Kits**—RXPF-01
RXPF-02



Brand	Unique Model Number Prefix	Descriptor (3 Characters)	Series (3 Characters)	System (2 Characters)	Type (2 Characters)
UHC	-	TST	101	GE	MS
UHC=Ruud		TST=Thermostat	100=Non-Programmable 200=Programmable 300=Deluxe Programmable 400=Special Applications/Programmable 500=Communicating/Programmable	GE=Gas/Oil/Electric HP=Heat Pump MD=Modulating Furnace DF=Dual Fuel UN=Universal AC/HP/GE CM=Communicating	SS=Single-Stage MS=Multi-Stage

* Photos are representative. Actual models may vary.
For detailed thermostat match-up information, see specification sheet form number T22-001.

Ruud Heat Pump System

More than a reverse cycle air conditioner, it's a specially designed combination Winter/Summer comfort system using a single indoor coil for heating and cooling.

For all season home comfort, performance and energy conservation, choose a Ruud UPNL- JEZ Heat Pump and a RHSL, RHLL, or RHKL Series Air Handler.

To choose an Air Handler designed for use with the UPNL- JEZ Heat Pump, refer to the Performance Data Tables and/or the air handler specification sheet.

Performance Data AHRI Standard Conditions—UPNL- JEZ

Note: Only these combinations of indoor/outdoor units are approved and any other combinations should not be used.

Model Numbers		AHRI Cooling Performance							AHRI Heating Performance (70°F [21°C] Indoor)				
		80°F [26.5°C] DB/67°F [19.5°C] WB Indoor Air 95°F [35°C] DB Outdoor Air							Outdoor Air 47°F [8.5°C] DB/ 43°F [6°C] WB DOE High Temp.		Outdoor Air 17°F [-8.5°C] DB/ 15°F [-9.5°C] WB DOE Low Temp.		DOE Region IV HSPF
Outdoor Unit UPNL-	Indoor Coil and/or Air Handler	Total Capacity BTU/H [kW]	Net Sens. BTU/H [kW]	Net Latent BTU/H [kW]	EER	SEER	Snd. Rate dB	Indoor CFM [L/s]	DOE High Temp.		DOE Low Temp.		
									BTU/H [kW]	COP	BTU/H [kW]	COP	
Rev. 6/30/10	-HSL-HM2417 (RCSL-H*2417) ①	23,400 [6.9]	17,350 [5.1]	6,050 [1.8]	11.00	13.00	70	825 [389]	22,800 [6.7]	3.56	14,100 [4.1]	2.34	8.50
	RCFL-H*2414+RXMD-C04	23,200 [6.8]	17,150 [5.0]	6,050 [1.8]	10.60	13.00	70	825 [389]	23,000 [6.7]	3.46	14,300 [4.2]	2.30	8.15
024JEZ	RCFL-H*2417 (-GFD-06?MCK?)	23,400 [6.9]	17,400 [5.1]	6,000 [1.8]	11.30	13.50	70	800 [378]	22,000 [6.4]	3.92	13,300 [3.9]	2.56	9.20
	RCFL-H*2417 (-GFD-07?MCK?)	23,600 [6.9]	17,450 [5.1]	6,150 [1.8]	11.40	13.50	70	800 [378]	22,000 [6.4]	3.92	13,300 [3.9]	2.56	9.20
	RCFL-H*2417 (-GFE-06?MCK?)	23,600 [6.9]	17,500 [5.1]	6,100 [1.8]	11.55	14.00	70	800 [378]	22,400 [6.6]	3.68	13,800 [4.0]	2.42	9.00
	RCFL-H*2417 (-GFE-07?MCK?)	23,600 [6.9]	17,500 [5.1]	6,100 [1.8]	11.50	14.00	70	825 [389]	22,400 [6.6]	3.66	13,800 [4.0]	2.42	9.00
	RCFL-H*2417 (-GGD-06?MCK?)	23,600 [6.9]	17,500 [5.1]	6,100 [1.8]	11.60	14.00	70	800 [378]	22,000 [6.4]	3.92	13,300 [3.9]	2.56	9.20
	RCFL-H*2417 (-GGD-07?MCK?)	23,600 [6.9]	17,450 [5.1]	6,150 [1.8]	11.50	14.00	70	800 [378]	22,000 [6.4]	3.92	13,300 [3.9]	2.56	9.20
	RCFL-H*2417 (-GGE-06?MCK?)	23,600 [6.9]	17,500 [5.1]	6,100 [1.8]	11.60	14.00	70	825 [389]	22,400 [6.6]	3.70	13,700 [4.0]	2.44	9.00
	RCFL-H*2417 (-GGE-07?MCK?)	23,600 [6.9]	17,500 [5.1]	6,100 [1.8]	11.60	14.00	70	800 [378]	22,400 [6.6]	3.68	13,800 [4.0]	2.42	9.00
	RCFL-H*2417 (-GJD-06?MCK?)	23,600 [6.9]	17,500 [5.1]	6,100 [1.8]	11.60	14.00	70	800 [378]	22,000 [6.4]	3.92	13,300 [3.9]	2.56	9.20
	RCFL-H*2417 (-GJD-07?MCK?)	23,600 [6.9]	17,450 [5.1]	6,150 [1.8]	11.50	14.00	70	800 [378]	22,000 [6.4]	3.92	13,300 [3.9]	2.56	9.20
	RCFL-H*2417 (-GJF-06?MCK?)	23,200 [6.8]	16,800 [4.9]	6,400 [1.9]	11.55	14.00	70	725 [342]	22,400 [6.6]	3.72	13,700 [4.0]	2.46	9.00
	RCFL-H*2417 (-GJF-07?MCK?)	23,600 [6.9]	17,500 [5.1]	6,100 [1.8]	11.60	14.00	70	800 [378]	22,400 [6.6]	3.70	13,800 [4.0]	2.44	9.00
	RCFL-H*2417 (-GLE-07?AMK?)	23,600 [6.9]	17,500 [5.1]	6,100 [1.8]	11.75	14.00	70	800 [378]	22,400 [6.6]	3.72	13,700 [4.0]	2.44	9.00
	RCFL-H*2417 (-GLR-07?AMK?)	23,600 [6.9]	17,550 [5.1]	6,050 [1.8]	11.75	14.00	70	800 [378]	22,000 [6.4]	3.92	13,300 [3.9]	2.56	9.20
	RCFL-H*2417 (RGLT-07?AME?)	23,600 [6.9]	17,500 [5.1]	6,100 [1.8]	11.50	14.00	70	850 [401]	22,400 [6.6]	3.68	13,800 [4.0]	2.42	8.50
	RCFL-H*2417 (-GPE-05?BMK?)	23,600 [6.9]	17,500 [5.1]	6,100 [1.8]	11.65	14.00	70	800 [378]	22,400 [6.6]	3.70	13,700 [4.0]	2.44	9.00
	RCFL-H*2417 (-GPE-07?AMK?)	23,600 [6.9]	17,500 [5.1]	6,100 [1.8]	11.65	14.00	70	825 [389]	22,400 [6.6]	3.70	13,700 [4.0]	2.44	9.00
	RCFL-H*2417 (-GPR-05?BMK?)	23,200 [6.8]	17,250 [5.1]	5,950 [1.7]	11.30	13.50	70	775 [366]	22,600 [6.6]	3.64	13,800 [4.0]	2.40	8.45
	RCFL-H*2417 (-GPR-07?AMK?)	23,600 [6.9]	17,500 [5.1]	6,100 [1.8]	11.65	14.00	70	800 [378]	22,600 [6.6]	3.64	13,800 [4.0]	2.40	8.45
	RCFL-H*2417 (RGPT-05?BMK?)	23,600 [6.9]	17,500 [5.1]	6,100 [1.8]	11.00	13.50	70	850 [401]	22,600 [6.6]	3.64	13,900 [4.1]	2.40	8.50
	RCFL-H*2417 (RGPT-07?AME?)	23,600 [6.9]	17,500 [5.1]	6,100 [1.8]	11.50	14.00	70	850 [401]	22,600 [6.6]	3.66	13,800 [4.0]	2.42	8.50
	RCFL-H*2417 (-GRM-04?MAE?)	23,400 [6.9]	17,400 [5.1]	6,000 [1.8]	11.35	13.50	70	800 [378]	22,600 [6.6]	3.64	13,900 [4.1]	2.40	8.50
	RCFL-H*2417 (-GRM-06?MAE?)	23,600 [6.9]	17,450 [5.1]	6,150 [1.8]	11.40	13.50	70	825 [389]	22,600 [6.6]	3.64	13,800 [4.0]	2.40	8.50
	RCFL-H*2417 (-GRM-07?MAE?)	23,400 [6.9]	17,300 [5.1]	6,100 [1.8]	11.05	13.00	70	850 [401]	22,600 [6.6]	3.58	14,000 [4.1]	2.38	8.50
	RCFL-H*2417 (-GTM-06?MAE?)	23,400 [6.9]	17,100 [5.0]	6,300 [1.8]	11.65	14.00	70	750 [354]	22,400 [6.6]	3.74	13,600 [4.0]	2.46	9.00
	ROCA-070E03 (RCFL-H*2417)	23,600 [6.9]	17,500 [5.1]	6,100 [1.8]	11.50	14.00	70	800 [378]	22,400 [6.6]	3.72	13,700 [4.0]	2.44	9.00

① Highest sales volume tested combination required by DOE test procedures.

[] Designates Metric Conversions

Performance Data AHRI Standard Conditions—UPNL- JEZ (Con't.)

Note: Only these combinations of indoor/outdoor units are approved and any other combinations should not be used.

Model Numbers		AHRI Cooling Performance							AHRI Heating Performance (70°F [21°C] Indoor)				
		80°F [26.5°C] DB/67°F [19.5°C] WB Indoor Air 95°F [35°C] DB Outdoor Air							Outdoor Air 47°F [8.5°C] DB/ 43°F [6°C] WB DOE High Temp.		Outdoor Air 17°F [-8.5°C] DB/ 15°F [-9.5°C] WB DOE Low Temp.		DOE Region IV HSPF
Outdoor Unit UPNL-	Indoor Coil and/or Air Handler	Total Capacity BTU/H [kW]	Net Sens. BTU/H [kW]	Net Latent BTU/H [kW]	EER	SEER	Snd. Rate dB	Indoor CFM [L/s]	BTU/H [kW]	COP	BTU/H [kW]	COP	
Rev. 6/30/10 024JEZ	ROCA-070E04 (RCFL-H*2417)	23,600 [6.9]	17,500 [5.1]	6,100 [1.8]	11.50	14.00	70	800 [378]	22,400 [6.6]	3.72	13,700 [4.0]	2.44	9.00
	ROLA-070E03 (RCFL-H*2417)	23,600 [6.9]	17,500 [5.1]	6,100 [1.8]	11.50	14.00	70	800 [378]	22,400 [6.6]	3.72	13,700 [4.0]	2.44	9.00
	ROLA-070E04 (RCFL-H*2417)	23,600 [6.9]	17,500 [5.1]	6,100 [1.8]	11.50	14.00	70	800 [378]	22,400 [6.6]	3.72	13,700 [4.0]	2.44	9.00
	RCFL-H*2417+RXMD-C04	23,200 [6.8]	17,150 [5.0]	6,050 [1.8]	10.60	13.00	70	825 [389]	23,000 [6.7]	3.46	14,300 [4.2]	2.30	8.15
	-BHP-17 (RCHL-24A*)	23,000 [6.7]	16,600 [4.9]	6,400 [1.9]	11.30	13.50	70	800 [378]	23,200 [6.8]	3.52	14,500 [4.2]	2.34	8.50
	-HKL-HM2417 (RCSL-H*2417)	23,600 [6.9]	17,500 [5.1]	6,100 [1.8]	11.60	14.00	70	850 [401]	22,000 [6.4]	3.92	13,300 [3.9]	2.56	9.20
	-HLL-HM2417 (RCSL-H*2417)	23,600 [6.9]	17,450 [5.1]	6,150 [1.8]	12.00	14.00	70	775 [366]	22,400 [6.6]	3.76	13,600 [4.0]	2.46	8.90
030JEZ	RCFL-H*3621 (-GPR-07?AMK?)	29,600 [8.7]	22,050 [6.5]	7,550 [2.2]	12.25	14.00	71	1,000 [472]	31,000 [9.1]	4.00	19,200 [5.6]	2.64	9.25
031JEZ	-HSL-HM3017 (RCSL-H*3617) ①	28,400 [8.3]	20,950 [6.1]	7,450 [2.2]	11.00	13.00	73	1,000 [472]	26,800 [7.9]	3.60	17,500 [5.1]	2.50	9.00
	RCFL-H*3617	28,200 [8.3]	20,750 [6.1]	7,450 [2.2]	10.50	13.00	73	1,000 [472]	27,000 [7.9]	3.52	17,700 [5.2]	2.46	9.00
	RCFL-H*3617 (-GFD-07?MCK?)	28,400 [8.3]	20,900 [6.1]	7,500 [2.2]	11.00	13.50	73	1,000 [472]	26,600 [7.8]	3.62	17,400 [5.1]	2.52	9.00
	RCFL-H*3617 (-GFE-06?MCK?)	28,600 [8.4]	21,100 [6.2]	7,500 [2.2]	11.45	13.50	73	1,000 [472]	26,600 [7.8]	3.62	17,400 [5.1]	2.52	9.00
	RCFL-H*3617 (-GFE-07?MCK?)	28,400 [8.3]	20,950 [6.1]	7,450 [2.2]	11.35	13.50	73	1,025 [484]	26,800 [7.9]	3.62	17,400 [5.1]	2.50	9.00
	RCFL-H*3617 (-GGD-06?MCK?)	28,600 [8.4]	21,100 [6.2]	7,500 [2.2]	11.00	13.50	73	1,000 [472]	26,600 [7.8]	3.64	17,300 [5.1]	2.52	9.00
	RCFL-H*3617 (-GGD-07?MCK?)	28,400 [8.3]	20,950 [6.1]	7,450 [2.2]	11.00	13.50	73	1,025 [484]	26,600 [7.8]	3.62	17,400 [5.1]	2.52	9.00
	RCFL-H*3617 (-GGE-06?MCK?)	28,600 [8.4]	21,100 [6.2]	7,500 [2.2]	11.55	13.50	73	1,025 [484]	26,600 [7.8]	3.66	17,300 [5.1]	2.54	9.00
	RCFL-H*3617 (-GGE-07?MCK?)	28,600 [8.4]	21,100 [6.2]	7,500 [2.2]	11.50	13.50	73	1,025 [484]	26,600 [7.8]	3.64	17,300 [5.1]	2.52	9.00
	RCFL-H*3617 (-GJD-06?MCK?)	28,600 [8.4]	21,100 [6.2]	7,500 [2.2]	11.00	13.50	73	1,000 [472]	26,600 [7.8]	3.64	17,300 [5.1]	2.52	9.00
	RCFL-H*3617 (-GJD-07?MCK?)	28,400 [8.3]	20,950 [6.1]	7,450 [2.2]	11.00	13.50	73	1,025 [484]	26,600 [7.8]	3.62	17,400 [5.1]	2.52	9.00
	RCFL-H*3617 (-GJF-06?MCK?)	28,600 [8.4]	21,100 [6.2]	7,500 [2.2]	11.55	13.50	73	1,025 [484]	26,600 [7.8]	3.66	17,300 [5.1]	2.54	9.00
	RCFL-H*3617 (-GJF-07?MCK?)	28,600 [8.4]	21,100 [6.2]	7,500 [2.2]	11.50	13.50	73	1,025 [484]	26,600 [7.8]	3.64	17,300 [5.1]	2.52	9.00
	RCFL-H*3617 (-GLE-07?AMK?)	28,600 [8.4]	21,100 [6.2]	7,500 [2.2]	11.75	14.00	73	1,025 [484]	26,400 [7.7]	3.70	17,200 [5.0]	2.56	9.00
	RCFL-H*3617 (-GLR-07?AMK?)	28,600 [8.4]	21,100 [6.2]	7,500 [2.2]	11.50	14.00	73	1,025 [484]	26,600 [7.8]	3.68	17,200 [5.0]	2.56	9.00
	RCFL-H*3617 (RGLT-07?AME?)	28,800 [8.4]	21,450 [6.3]	7,350 [2.2]	11.50	14.00	73	1,050 [495]	26,600 [7.8]	3.66	17,300 [5.1]	2.54	9.00
	RCFL-H*3617 (-GPE-05?BMK?)	28,600 [8.4]	21,100 [6.2]	7,500 [2.2]	11.65	13.50	73	975 [460]	26,600 [7.8]	3.68	17,200 [5.0]	2.54	9.00
	RCFL-H*3617 (-GPE-07?AMK?)	28,600 [8.4]	21,100 [6.2]	7,500 [2.2]	11.70	14.00	73	1,000 [472]	26,600 [7.8]	3.68	17,200 [5.0]	2.54	9.00
	RCFL-H*3617 (-GPR-05?BMK?)	28,400 [8.3]	20,950 [6.1]	7,450 [2.2]	11.00	13.50	73	1,000 [472]	26,800 [7.9]	2.62	17,400 [5.1]	2.52	9.00
	RCFL-H*3617 (-GPR-07?AMK?)	28,600 [8.4]	21,100 [6.2]	7,500 [2.2]	11.50	13.50	73	1,000 [472]	26,600 [7.8]	3.68	17,200 [5.0]	2.56	9.00

① Highest sales volume tested combination required by DOE test procedures.

[] Designates Metric Conversions

Performance Data AHRI Standard Conditions—UPNL- JEZ (Con't.)

Note: Only these combinations of indoor/outdoor units are approved and any other combinations should not be used.

Model Numbers		AHRI Cooling Performance							AHRI Heating Performance (70°F [21°C] Indoor)				
		80°F [26.5°C] DB/67°F [19.5°C] WB Indoor Air 95°F [35°C] DB Outdoor Air							Outdoor Air 47°F [8.5°C] DB/ 43°F [6°C] WB DOE High Temp.		Outdoor Air 17°F [-8.5°C] DB/ 15°F [-9.5°C] WB DOE Low Temp.		DOE Region IV HSPF
Outdoor Unit UPNL-	Indoor Coil and/or Air Handler	Total Capacity BTU/H [kW]	Net Sens. BTU/H [kW]	Net Latent BTU/H [kW]	EER	SEER	Snd. Rate dB	Indoor CFM [L/s]	BTU/H [kW]	COP	BTU/H [kW]	COP	
031JEZ	Rev. 6/30/10 RCFL-H*3617 (RGPT-05?BMK?)	28,800 [8.4]	21,500 [6.3]	7,300 [2.1]	11.00	13.50	73	1,050 [495]	26,800 [7.9]	3.60	17,400 [5.1]	2.50	9.00
	RCFL-H*3617 (RGPT-07?AME?)	28,800 [8.4]	21,500 [6.3]	7,300 [2.1]	11.00	13.50	73	1,050 [495]	26,600 [7.8]	3.64	17,300 [5.1]	2.52	9.00
	RCFL-H*3617 (-GRM-04?MAE?)	28,400 [8.3]	20,950 [6.1]	7,450 [2.2]	11.20	13.00	73	1,025 [484]	26,800 [7.9]	3.58	17,500 [5.1]	2.48	9.00
	RCFL-H*3617 (-GRM-06?MAE?)	28,400 [8.3]	20,950 [6.1]	7,450 [2.2]	11.35	13.00	73	1,000 [472]	26,800 [7.9]	3.60	17,400 [5.1]	2.50	9.00
	RCFL-H*3617 (-GRM-07?MAE?)	28,200 [8.3]	20,800 [6.1]	7,400 [2.2]	10.95	13.00	73	1,025 [484]	27,000 [7.9]	3.52	17,700 [5.2]	2.46	9.00
	RCFL-H*3617 (-GRM-07?YBG?)	28,000 [8.2]	20,400 [6.0]	7,600 [2.2]	11.05	13.00	73	975 [460]	26,800 [7.9]	3.58	17,500 [5.1]	2.48	9.00
	RCFL-H*3617 (-GTM-06?MAE?)	28,400 [8.3]	20,950 [6.1]	7,450 [2.2]	11.40	13.50	73	1,025 [484]	26,600 [7.8]	3.64	17,400 [5.1]	2.52	9.00
	ROCA-070E03 (RCFL-H*3617)	28,600 [8.4]	21,100 [6.2]	7,500 [2.2]	11.50	14.00	73	1,000 [472]	26,400 [7.7]	3.70	17,200 [5.0]	2.56	9.00
	ROCA-070E04 (RCFL-H*3617)	28,600 [8.4]	21,100 [6.2]	7,500 [2.2]	11.50	14.00	73	1,000 [472]	26,400 [7.7]	3.70	17,200 [5.0]	2.56	9.00
	ROLA-070E03 (RCFL-H*3617)	28,400 [8.3]	20,500 [6.0]	7,900 [2.3]	11.50	14.00	73	900 [425]	26,400 [7.7]	3.78	17,000 [5.0]	2.60	9.00
	ROLA-070E04 (RCFL-H*3617)	28,600 [8.4]	21,100 [6.2]	7,500 [2.2]	11.50	14.00	73	1,025 [484]	26,400 [7.7]	3.70	17,200 [5.0]	2.56	9.00
	RCFL-H*3621	28,200 [8.3]	20,750 [6.1]	7,450 [2.2]	10.50	13.00	73	1,000 [472]	27,000 [7.9]	3.52	17,700 [5.2]	2.46	9.00
	RCFL-H*3621 (-GFD-07?MCK?)	28,600 [8.4]	21,100 [6.2]	7,500 [2.2]	11.00	13.50	73	1,000 [472]	26,600 [7.8]	3.64	17,300 [5.1]	2.52	9.00
	RCFL-H*3621 (-GFE-06?MCK?)	28,600 [8.4]	21,100 [6.2]	7,500 [2.2]	11.50	13.50	73	1,000 [472]	26,600 [7.8]	3.64	17,300 [5.1]	2.52	9.00
	RCFL-H*3621 (-GFE-07?MCK?)	28,400 [8.3]	20,950 [6.1]	7,450 [2.2]	11.40	13.50	73	1,025 [484]	26,600 [7.8]	3.62	17,400 [5.1]	2.52	9.00
	RCFL-H*3621 (-GFE-09?ZCM?)	28,800 [8.4]	21,250 [6.2]	7,550 [2.2]	11.90	14.00	73	975 [460]	26,400 [7.7]	3.72	17,100 [5.0]	2.58	9.00
	RCFL-H*3621 (-GFE-10?ZCM?)	28,800 [8.4]	21,250 [6.2]	7,550 [2.2]	11.80	14.00	73	1,000 [472]	26,400 [7.7]	3.72	17,100 [5.0]	2.56	9.00
	RCFL-H*3621 (-GGD-06?MCK?)	28,600 [8.4]	21,100 [6.2]	7,500 [2.2]	11.50	13.50	73	1,000 [472]	26,600 [7.8]	2.66	17,300 [5.1]	2.54	9.00
	RCFL-H*3621 (-GGD-07?MCK?)	28,600 [8.4]	21,100 [6.2]	7,500 [2.2]	11.00	13.50	73	1,025 [484]	26,600 [7.8]	3.64	17,300 [5.1]	2.52	9.00
	RCFL-H*3621 (-GGE-06?MCK?)	28,600 [8.4]	21,100 [6.2]	7,500 [2.2]	11.60	13.50	73	1,025 [484]	26,600 [7.8]	3.68	17,200 [5.0]	2.54	9.00
	RCFL-H*3621 (-GGE-07?MCK?)	28,600 [8.4]	21,100 [6.2]	7,500 [2.2]	11.55	13.50	73	1,025 [484]	26,600 [7.8]	3.66	17,300 [5.1]	2.54	9.00
	RCFL-H*3621 (-GGE-09?ZCM?)	28,800 [8.4]	21,250 [6.2]	7,550 [2.2]	11.90	14.00	73	1,000 [472]	26,400 [7.7]	3.74	17,100 [5.0]	2.58	9.00
	RCFL-H*3621 (-GGE-10?ZCM?)	28,800 [8.4]	21,250 [6.2]	7,550 [2.2]	11.85	14.00	73	1,000 [472]	26,400 [7.7]	3.72	17,100 [5.0]	2.58	9.00
	RCFL-H*3621 (-GJD-06?MCK?)	28,600 [8.4]	21,100 [6.2]	7,500 [2.2]	11.50	13.50	73	1,000 [472]	26,600 [7.8]	2.66	17,300 [5.1]	2.54	9.00
	RCFL-H*3621 (-GJD-07?MCK?)	28,600 [8.4]	21,100 [6.2]	7,500 [2.2]	11.00	13.50	73	1,025 [484]	26,600 [7.8]	3.64	17,300 [5.1]	2.52	9.00
	RCFL-H*3621 (-GJF-06?MCK?)	28,600 [8.4]	21,100 [6.2]	7,500 [2.2]	11.60	13.50	73	1,025 [484]	26,600 [7.8]	3.68	17,200 [5.0]	2.54	9.00
	RCFL-H*3621 (-GJF-07?MCK?)	28,600 [8.4]	21,100 [6.2]	7,500 [2.2]	11.55	13.50	73	1,025 [484]	26,600 [7.8]	3.66	17,300 [5.1]	2.54	9.00
	RCFL-H*3621 (-GJF-09?ZCM?)	28,800 [8.4]	21,250 [6.2]	7,550 [2.2]	11.90	14.00	73	1,000 [472]	26,400 [7.7]	3.74	17,100 [5.0]	2.58	9.00

① Highest sales volume tested combination required by DOE test procedures.

[] Designates Metric Conversions

Performance Data AHRI Standard Conditions—UPNL- JEZ (Con't.)

Note: Only these combinations of indoor/outdoor units are approved and any other combinations should not be used.

Model Numbers		AHRI Cooling Performance							AHRI Heating Performance (70°F [21°C] Indoor)				
		80°F [26.5°C] DB/67°F [19.5°C] WB Indoor Air 95°F [35°C] DB Outdoor Air							Outdoor Air 47°F [8.5°C] DB/ 43°F [6°C] WB DOE High Temp.		Outdoor Air 17°F [-8.5°C] DB/ 15°F [-9.5°C] WB DOE Low Temp.		DOE Region IV HSPF
Outdoor Unit UPNL-	Indoor Coil and/or Air Handler	Total Capacity BTU/H [kW]	Net Sens. BTU/H [kW]	Net Latent BTU/H [kW]	EER	SEER	Snd. Rate dB	Indoor CFM [L/s]	BTU/H [kW]	COP	BTU/H [kW]	COP	
Rev. 6/30/10	-HKL-HM3617 (RCSL-H*3617)	28,800 [8.4]	21,250 [6.2]	7,550 [2.2]	11.50	14.00	73	1,025 [484]	26,400 [7.7]	3.74	17,100 [5.0]	2.58	9.50
031JEZ	-HLL-HM3617 (RCSL-H*3617)	28,800 [8.4]	21,250 [6.2]	7,550 [2.2]	12.00	14.50	73	1,000 [472]	26,400 [7.7]	3.76	17,000 [5.0]	2.60	9.50
036JEZ	-HSL-HM3617 (RCSL-H*3617) ①	38,000 [11.1]	26,850 [7.9]	11,150 [3.3]	11.45	13.00	74	1,200 [566]	39,500 [11.6]	3.54	26,400 [7.7]	2.60	9.00
	RCFL-H*3617	37,600 [11.0]	26,550 [7.8]	11,050 [3.2]	11.20	13.00	74	1,100 [519]	39,000 [11.4]	3.50	26,000 [7.6]	2.64	9.00
	RCFL-H*3617 (-GGE-06?MCK?)	39,000 [11.4]	28,350 [8.3]	10,650 [3.1]	11.55	13.00	74	1,200 [566]	42,500 [12.5]	3.56	28,000 [8.2]	2.60	9.00
	RCFL-H*3617 (-GGE-07?MCK?)	39,000 [11.4]	28,400 [8.3]	10,600 [3.1]	11.50	13.00	74	1,200 [566]	42,500 [12.5]	3.54	28,000 [8.2]	2.58	9.00
	RCFL-H*3617 (-GJF-06?MCK?)	39,000 [11.4]	28,350 [8.3]	10,650 [3.1]	11.55	13.00	74	1,200 [566]	42,500 [12.5]	3.56	28,000 [8.2]	2.60	9.00
	RCFL-H*3617 (-GJF-07?MCK?)	39,000 [11.4]	28,400 [8.3]	10,600 [3.1]	11.50	13.00	74	1,200 [566]	42,500 [12.5]	3.54	28,000 [8.2]	2.60	9.00
	RCFL-H*3617 (-GLE-07?AMK?)	39,000 [11.4]	28,350 [8.3]	10,650 [3.1]	11.75	13.50	74	1,200 [566]	42,500 [12.5]	3.60	27,800 [8.1]	2.62	9.00
	RCFL-H*3617 (-GLR-07?AMK?)	39,000 [11.4]	28,350 [8.3]	10,650 [3.1]	11.70	13.50	74	1,200 [566]	42,500 [12.5]	3.58	27,800 [8.1]	2.62	9.00
	RCFL-H*3617 (RGLT-07?AME?)	39,000 [11.4]	28,300 [8.3]	10,700 [3.1]	11.50	13.50	74	1,200 [566]	42,500 [12.5]	3.58	27,800 [8.1]	2.62	9.00
	RCFL-H*3617 (-GPE-05?BMK?)	39,000 [11.4]	28,350 [8.3]	10,650 [3.1]	11.55	13.00	74	1,200 [566]	42,500 [12.5]	3.56	28,000 [8.2]	2.60	9.00
	RCFL-H*3617 (-GPE-07?AMK?)	39,000 [11.4]	28,500 [8.4]	10,500 [3.1]	11.60	13.00	74	1,225 [578]	42,500 [12.5]	3.56	28,000 [8.2]	2.60	9.00
	RCFL-H*3617 (RGPT-05?BMK?)	39,000 [11.4]	28,250 [8.3]	10,750 [3.1]	11.00	13.00	74	1,175 [554]	42,500 [12.5]	3.54	28,000 [8.2]	2.58	9.00
	RCFL-H*3617 (RGPT-07?AME?)	39,000 [11.4]	28,250 [8.3]	10,750 [3.1]	11.00	13.50	74	1,175 [554]	42,500 [12.5]	3.56	28,000 [8.2]	2.60	9.00
	RCFL-H*3617 (-GRM-04?MAE?)	39,000 [11.4]	28,450 [8.3]	10,550 [3.1]	11.25	13.00	74	1,200 [566]	43,000 [12.6]	3.50	28,200 [8.3]	2.66	9.00
	RCFL-H*3617 (-GRM-06?MAE?)	38,500 [11.3]	27,800 [8.1]	10,700 [3.1]	11.30	13.00	74	1,175 [554]	42,500 [12.5]	3.50	28,200 [8.3]	2.66	9.00
	RCFL-H*3617 (-GRM-09?ZAJ?)	39,000 [11.4]	28,450 [8.3]	10,550 [3.1]	11.65	13.50	74	1,225 [578]	42,500 [12.5]	3.56	28,000 [8.2]	2.72	9.00
	RCFL-H*3617 (-GRM-10?ZAJ?)	39,000 [11.4]	28,100 [8.2]	10,900 [3.2]	11.75	13.50	74	1,150 [543]	42,500 [12.5]	3.60	27,800 [8.1]	2.74	9.00
	ROCA-070E03 (RCFL-H*3617)	39,000 [11.4]	28,350 [8.3]	10,650 [3.1]	11.50	13.50	74	1,200 [566]	42,500 [12.5]	3.58	27,800 [8.1]	2.62	9.00
	ROCA-070E04 (RCFL-H*3617)	39,000 [11.4]	28,350 [8.3]	10,650 [3.1]	11.50	13.50	74	1,200 [566]	42,500 [12.5]	3.58	27,800 [8.1]	2.62	9.00
	ROLA-070E03 (RCFL-H*3617)	39,000 [11.4]	28,150 [8.2]	10,850 [3.2]	11.50	13.50	74	1,175 [554]	42,000 [12.3]	3.64	27,600 [8.1]	2.66	9.00
	ROLA-070E04 (RCFL-H*3617)	39,000 [11.4]	28,150 [8.2]	10,850 [3.2]	11.50	13.50	74	1,175 [554]	42,000 [12.3]	3.64	27,600 [8.1]	2.66	9.00
	RCFL-H*3621	38,000 [11.1]	26,850 [7.9]	11,150 [3.3]	11.25	13.00	74	1,200 [566]	39,000 [11.4]	3.52	26,000 [7.6]	2.68	9.00
	RCFL-H*3621 (-GFE-09?ZCM?)	39,000 [11.4]	28,300 [8.3]	10,700 [3.1]	11.85	13.50	74	1,200 [566]	42,500 [12.5]	3.60	27,800 [8.1]	2.64	9.00
	RCFL-H*3621 (-GFE-10?ZCM?)	39,500 [11.6]	28,950 [8.5]	10,550 [3.1]	11.75	13.50	74	1,225 [578]	42,500 [12.5]	3.60	27,800 [8.1]	2.62	9.00
	RCFL-H*3621 (-GGD-09?ZCM?)	38,500 [11.3]	27,250 [8.0]	11,250 [3.3]	11.85	13.50	74	1,175 [554]	38,500 [11.3]	3.88	25,600 [7.5]	2.96	9.00
	RCFL-H*3621 (-GGD-10?ZCM?)	38,500 [11.3]	27,250 [8.0]	11,250 [3.3]	11.85	13.50	74	1,175 [554]	38,500 [11.3]	3.88	25,600 [7.5]	2.96	9.00

① Highest sales volume tested combination required by DOE test procedures.

[] Designates Metric Conversions

Performance Data AHRI Standard Conditions—UPNL- JEZ (Con't.)

Note: Only these combinations of indoor/outdoor units are approved and any other combinations should not be used.

Model Numbers		AHRI Cooling Performance							AHRI Heating Performance (70°F [21°C] Indoor)				
		80°F [26.5°C] DB/67°F [19.5°C] WB Indoor Air 95°F [35°C] DB Outdoor Air							Outdoor Air 47°F [8.5°C] DB/ 43°F [6°C] WB DOE High Temp.		Outdoor Air 17°F [-8.5°C] DB/ 15°F [-9.5°C] WB DOE Low Temp.		DOE Region IV HSPF
Outdoor Unit UPNL-	Indoor Coil and/or Air Handler	Total Capacity BTU/H [kW]	Net Sens. BTU/H [kW]	Net Latent BTU/H [kW]	EER	SEER	Snd. Rate dB	Indoor CFM [L/s]	BTU/H [kW]	COP	BTU/H [kW]	COP	
Rev. 6/30/10	RCFL-H*3621 (-GRM-06?MAE?)	38,500 [11.3]	27,800 [8.1]	10,700 [3.1]	11.30	13.00	74	1,175 [554]	42,500 [12.5]	3.50	28,200 [8.3]	2.66	9.00
	RCFL-H*3621 (-GRM-09?ZAJ?)	39,500 [11.6]	28,950 [8.5]	10,550 [3.1]	11.70	13.50	74	1,225 [578]	42,500 [12.5]	3.58	27,800 [8.1]	2.72	9.00
	RCFL-H*3621 (-GRM-10?ZAJ?)	39,000 [11.4]	28,050 [8.2]	10,950 [3.2]	11.80	13.50	74	1,150 [543]	42,500 [12.5]	3.60	27,800 [8.1]	2.74	9.00
	RCFL-H*3621 (-GRM-12?RAJ?)	39,500 [11.6]	28,900 [8.5]	10,600 [3.1]	11.90	13.50	74	1,225 [578]	42,000 [12.3]	3.62	27,800 [8.1]	2.74	9.00
	RCFL-H*3621 (-GTM-07?RBG?)	39,000 [11.4]	27,900 [8.2]	11,100 [3.3]	12.15	14.00	74	1,125 [531]	42,000 [12.3]	3.68	27,400 [8.0]	2.68	9.00
	RCFL-H*3621 (-GTM-09?ZAJ?)	39,500 [11.6]	28,900 [8.5]	10,600 [3.1]	11.90	13.50	74	1,225 [578]	42,000 [12.3]	3.62	27,600 [8.1]	2.64	9.00
	ROCA-070E03 (RCFL-H*3621)	39,000 [11.4]	28,350 [8.3]	10,650 [3.1]	11.50	13.50	74	1,200 [566]	42,500 [12.5]	3.60	27,800 [8.1]	2.62	9.00
	ROCA-070E04 (RCFL-H*3621)	39,000 [11.4]	28,350 [8.3]	10,650 [3.1]	11.50	13.50	74	1,200 [566]	42,500 [12.5]	3.60	27,800 [8.1]	2.62	9.00
	ROLA-070E03 (RCFL-H*3621)	39,000 [11.4]	28,150 [8.2]	10,850 [3.2]	11.50	14.00	74	1,175 [554]	42,000 [12.3]	3.64	27,600 [8.1]	2.66	9.00
	ROLA-070E04 (RCFL-H*3621)	39,000 [11.4]	28,150 [8.2]	10,850 [3.2]	11.50	14.00	74	1,175 [554]	42,000 [12.3]	3.64	27,600 [8.1]	2.66	9.00
	ROLA-115E05 (RCFL-H*3621)	39,500 [11.6]	28,750 [8.4]	10,750 [3.1]	11.50	14.00	74	1,200 [566]	42,000 [12.3]	3.66	27,600 [8.1]	2.66	9.00
	-BHP-21 (RCHL-36A*)	37,600 [11.0]	27,150 [8.0]	10,450 [3.1]	11.75	14.00	74	1,175 [554]	41,000 [12.0]	3.30	26,000 [7.6]	2.30	8.50
	-HKL-HM3617 (RCSL-H*3617)	38,500 [11.3]	27,250 [8.0]	11,250 [3.3]	11.85	13.50	74	1,225 [578]	38,500 [11.3]	3.88	25,800 [7.6]	2.96	9.00
	-HLL-HM3617 (RCSL-H*3617)	38,500 [11.3]	27,350 [8.0]	11,150 [3.3]	12.05	14.00	74	1,200 [566]	38,500 [11.3]	3.88	25,600 [7.5]	2.96	9.00
	-HSL-HM3621 (RCSL-H*3621)	38,000 [11.1]	26,850 [7.9]	11,150 [3.3]	11.45	13.00	74	1,200 [566]	39,500 [11.6]	3.54	26,400 [7.7]	2.60	9.00
037JEZ	-HSL-HM3617 (RCSL-H*3617) ①	35,200 [10.3]	25,550 [7.5]	9,650 [2.8]	11.00	13.00	76	1,175 [554]	37,200 [10.9]	3.58	23,800 [7.0]	2.46	9.00
	RCFL-H*3617	34,400 [10.1]	24,750 [7.3]	9,650 [2.8]	11.00	13.00	76	1,075 [507]	36,400 [10.7]	3.60	23,600 [6.9]	2.46	8.50
	RCFL-H*3617 (-GGE-06?MCK?)	36,000 [10.5]	26,900 [7.9]	9,100 [2.7]	11.50	13.50	76	1,200 [566]	37,200 [10.9]	3.62	23,600 [6.9]	2.48	9.00
	RCFL-H*3617 (-GGE-07?MCK?)	36,000 [10.5]	26,900 [7.9]	9,100 [2.7]	11.00	13.50	76	1,200 [566]	37,200 [10.9]	3.60	23,800 [7.0]	2.46	9.00
	RCFL-H*3617 (-GJF-06?MCK?)	36,000 [10.5]	26,900 [7.9]	9,100 [2.7]	11.50	13.50	76	1,200 [566]	37,200 [10.9]	3.62	23,600 [6.9]	2.48	9.00
	RCFL-H*3617 (-GJF-07?MCK?)	36,000 [10.5]	26,900 [7.9]	9,100 [2.7]	11.00	13.50	76	1,200 [566]	37,200 [10.9]	3.60	23,800 [7.0]	2.46	9.00
	RCFL-H*3617 (-GLE-07?AMK?)	36,200 [10.6]	27,050 [7.9]	9,150 [2.7]	11.50	13.50	76	1,200 [566]	37,000 [10.8]	3.64	23,600 [6.9]	2.50	9.00
	RCFL-H*3617 (-GLR-07?AMK?)	36,200 [10.6]	27,050 [7.9]	9,150 [2.7]	11.50	13.50	76	1,200 [566]	37,000 [10.8]	3.64	23,600 [6.9]	2.48	9.00
	RCFL-H*3617 (RGLT-07?AME?)	36,200 [10.6]	27,050 [7.9]	9,150 [2.7]	11.50	14.00	76	1,200 [566]	37,000 [10.8]	3.64	23,600 [6.9]	2.48	9.00
	RCFL-H*3617 (-GPE-05?BMK?)	36,000 [10.5]	26,900 [7.9]	9,100 [2.7]	11.50	13.50	76	1,200 [566]	37,200 [10.9]	3.60	23,800 [7.0]	2.46	9.00
	RCFL-H*3617 (-GPE-07?AMK?)	36,200 [10.6]	27,200 [8.0]	9,000 [2.6]	11.50	13.50	76	1,225 [578]	37,000 [10.8]	3.62	23,600 [6.9]	2.48	9.00
	RCFL-H*3617 (-GPR-07?AMK?)	36,000 [10.5]	26,850 [7.9]	9,150 [2.7]	11.50	13.50	76	1,200 [566]	37,000 [10.8]	3.62	23,600 [6.9]	2.48	9.00
	RCFL-H*3617 (RGPT-07?AME?)	36,000 [10.5]	26,750 [7.8]	9,250 [2.7]	11.50	13.50	76	1,175 [554]	37,000 [10.8]	3.62	23,600 [6.9]	2.48	9.00

① Highest sales volume tested combination required by DOE test procedures.

[] Designates Metric Conversions

Performance Data AHRI Standard Conditions—UPNL- JEZ (Con't.)

Note: Only these combinations of indoor/outdoor units are approved and any other combinations should not be used.

Model Numbers		AHRI Cooling Performance							AHRI Heating Performance (70°F [21°C] Indoor)				DOE Region IV HSPF
		80°F [26.5°C] DB/67°F [19.5°C] WB Indoor Air 95°F [35°C] DB Outdoor Air							Outdoor Air 47°F [8.5°C] DB/ 43°F [6°C] WB DOE High Temp.		Outdoor Air 17°F [-8.5°C] DB/ 15°F [-9.5°C] WB DOE Low Temp.		
Outdoor Unit UPNL-	Indoor Coil and/or Air Handler	Total Capacity BTU/H [kW]	Net Sens. BTU/H [kW]	Net Latent BTU/H [kW]	EER	SEER	Snd. Rate dB	Indoor CFM [L/s]	DOE High Temp.		DOE Low Temp.		
									BTU/H [kW]	COP	BTU/H [kW]	COP	
Rev. 6/30/10 037JEZ	RCFL-H*3621 (-GPR-07?AMK?)	36,200 [10.6]	27,050 [7.9]	9,150 [2.7]	11.50	13.50	76	1,200 [566]	37,000 [10.8]	3.64	23,600 [6.9]	2.48	9.00
	RCFL-H*3621 (-GPR-07?BRQ?)	36,600 [10.7]	27,450 [8.0]	9,150 [2.7]	12.00	14.50	76	1,225 [578]	36,600 [10.7]	3.74	23,200 [6.8]	2.54	9.00
	RCFL-H*3621 (-GPR-10?BRM?)	36,400 [10.7]	27,300 [8.0]	9,100 [2.7]	12.00	14.00	76	1,225 [578]	36,800 [10.8]	3.70	23,400 [6.9]	2.52	9.00
	RCFL-H*3621 (RGPT-05?BMK?)	36,000 [10.5]	26,900 [7.9]	9,100 [2.7]	11.50	13.50	76	1,200 [566]	37,200 [10.9]	3.58	23,800 [7.0]	2.46	9.00
	RCFL-H*3621 (RGPT-07?AME?)	36,000 [10.5]	26,850 [7.9]	9,150 [2.7]	11.50	13.50	76	1,200 [566]	37,000 [10.8]	3.62	23,600 [6.9]	2.48	9.00
	RCFL-H*3621 (RGPT-10?BRM?)	36,400 [10.7]	27,050 [7.9]	9,350 [2.7]	12.00	14.50	76	1,175 [554]	36,600 [10.7]	3.74	23,200 [6.8]	2.54	9.00
	RCFL-H*3621 (-GRM-07?YBG?)	35,400 [10.4]	25,700 [7.5]	9,700 [2.8]	11.50	13.50	76	1,050 [495]	36,400 [10.7]	3.66	23,200 [6.8]	2.50	9.00
	RCFL-H*3621 (-GRM-09?ZAJ?)	36,200 [10.6]	27,150 [8.0]	9,050 [2.7]	11.50	13.50	76	1,225 [578]	37,000 [10.8]	3.62	23,600 [6.9]	2.48	9.00
	RCFL-H*3621 (-GRM-10?ZAJ?)	36,000 [10.5]	26,600 [7.8]	9,400 [2.8]	11.50	14.00	76	1,150 [543]	37,000 [10.8]	3.66	23,400 [6.9]	2.50	9.00
	RCFL-H*3621 (-GTM-07?RBG?)	36,000 [10.5]	26,400 [7.7]	9,600 [2.8]	12.00	14.50	76	1,125 [531]	36,600 [10.7]	3.74	23,200 [6.8]	2.56	9.00
	RCFL-H*3621 (-GTM-09?ZAJ?)	35,800 [10.5]	26,000 [7.6]	9,800 [2.9]	12.00	14.50	76	1,100 [519]	36,600 [10.7]	3.76	23,200 [6.8]	2.56	9.00
	ROCA-070E03 (RCFL-H*3621)	36,200 [10.6]	27,050 [7.9]	9,150 [2.7]	11.50	13.50	76	1,200 [566]	37,000 [10.8]	3.66	23,600 [6.9]	2.50	9.00
	ROCA-070E04 (RCFL-H*3621)	36,200 [10.6]	27,050 [7.9]	9,150 [2.7]	11.50	13.50	76	1,200 [566]	37,000 [10.8]	3.66	23,600 [6.9]	2.50	9.00
	ROLA-070E03 (RCFL-H*3621)	36,200 [10.6]	26,850 [7.9]	9,350 [2.7]	11.50	14.00	76	1,175 [554]	36,800 [10.8]	3.70	23,400 [6.9]	2.54	9.00
	ROLA-070E04 (RCFL-H*3621)	36,200 [10.6]	26,850 [7.9]	9,350 [2.7]	11.50	14.00	76	1,175 [554]	36,800 [10.8]	3.70	23,400 [6.9]	2.54	9.00
	ROLA-115E05 (RCFL-H*3621)	36,400 [10.7]	27,200 [8.0]	9,200 [2.7]	11.50	14.00	76	1,200 [566]	36,600 [10.7]	3.72	23,200 [6.8]	2.54	9.00
	-BHP-21 (RCHL-36A1)	35,600 [10.4]	26,150 [7.7]	9,450 [2.8]	12.00	14.50	76	1,200 [566]	36,200 [10.6]	3.66	23,200 [6.8]	2.50	9.00
	-HKL-HM3617 (RCSL-H*3617)	36,600 [10.7]	27,500 [8.1]	9,100 [2.7]	12.00	14.00	76	1,225 [578]	36,800 [10.8]	3.70	23,400 [6.9]	2.52	9.00
	-HLL-HM3617 (RCSL-H*3617)	36,600 [10.7]	27,350 [8.0]	9,250 [2.7]	12.00	14.50	76	1,200 [566]	36,600 [10.7]	3.72	23,200 [6.8]	2.54	9.00
	042JEZ	-HSL-HM4221 (RCSL-H*4821) ①	43,000 [12.6]	30,800 [9.0]	12,200 [3.6]	11.60	13.00	74	1,400 [661]	42,500 [12.5]	3.64	28,600 [8.4]	2.66
RCFL-H*4821		42,500 [12.5]	30,300 [8.9]	12,200 [3.6]	11.50	13.00	74	1,400 [661]	42,500 [12.5]	3.62	28,600 [8.4]	2.64	9.55
RCFL-H*4821 (-GLR-07?BRQ?)		43,000 [12.6]	30,750 [9.0]	12,250 [3.6]	11.95	14.00	74	1,425 [672]	42,000 [12.3]	3.74	28,200 [8.3]	2.72	9.85
RCFL-H*4821 (-GLR-10?BRM?)		43,500 [12.7]	31,000 [9.1]	12,500 [3.7]	12.10	14.00	74	1,375 [649]	42,000 [12.3]	3.72	28,200 [8.3]	2.70	9.00
RCFL-H*4821 (-GPR-07?BRQ?)		43,000 [12.6]	30,950 [9.1]	12,050 [3.5]	12.05	14.00	74	1,400 [661]	42,500 [12.5]	3.68	28,400 [8.3]	2.68	9.00
RCFL-H*4821 (-GPR-10?BRM?)		43,000 [12.6]	30,800 [9.0]	12,200 [3.6]	11.80	14.00	74	1,425 [672]	42,500 [12.5]	3.68	28,400 [8.3]	2.68	9.00
RCFL-H*4824		42,500 [12.5]	30,300 [8.9]	12,200 [3.6]	11.50	13.00	74	1,400 [661]	42,500 [12.5]	3.62	28,600 [8.4]	2.64	9.55
RCFL-H*4824 (-GGD-12?RCM?)		43,500 [12.7]	31,050 [9.1]	12,450 [3.6]	11.95	14.00	74	1,450 [684]	42,000 [12.3]	3.72	28,200 [8.3]	2.70	9.00
RCFL-H*4824 (-GJD-12?RCM?)		43,500 [12.7]	31,050 [9.1]	12,450 [3.6]	11.95	14.00	74	1,450 [684]	42,000 [12.3]	3.72	28,200 [8.3]	2.70	9.00

① Highest sales volume tested combination required by DOE test procedures.

[] Designates Metric Conversions

Performance Data AHRI Standard Conditions—UPNL- JEZ (Con't.)

Note: Only these combinations of indoor/outdoor units are approved and any other combinations should not be used.

Model Numbers		AHRI Cooling Performance							AHRI Heating Performance (70°F [21°C] Indoor)				
		80°F [26.5°C] DB/67°F [19.5°C] WB Indoor Air 95°F [35°C] DB Outdoor Air							Outdoor Air 47°F [8.5°C] DB/ 43°F [6°C] WB DOE High Temp.		Outdoor Air 17°F [-8.5°C] DB/ 15°F [-9.5°C] WB DOE Low Temp.		DOE Region IV HSPF
Outdoor Unit UPNL-	Indoor Coil and/or Air Handler	Total Capacity BTU/H [kW]	Net Sens. BTU/H [kW]	Net Latent BTU/H [kW]	EER	SEER	Snd. Rate dB	Indoor CFM [L/s]	BTU/H [kW]	COP	BTU/H [kW]	COP	
Rev. 6/30/10	RCFL-H*4824 (-GLR-07?BRQ?)	43,000 [12.6]	30,750 [9.0]	12,250 [3.6]	11.95	14.00	74	1,425 [672]	42,000 [12.3]	3.74	28,200 [8.3]	2.72	9.00
	RCFL-H*4824 (-GLR-10?BRM?)	43,500 [12.7]	31,000 [9.1]	12,500 [3.7]	12.10	14.00	74	1,375 [649]	42,000 [12.3]	3.72	28,200 [8.3]	2.70	9.00
	RCFL-H*4824 (-GLR-12?ARM?)	43,000 [12.6]	30,950 [9.1]	12,050 [3.5]	12.05	14.00	74	1,425 [672]	42,000 [12.3]	3.72	28,200 [8.3]	2.70	9.00
	RCFL-H*4824 (-GPR-07?BRQ?)	43,000 [12.6]	30,950 [9.1]	12,050 [3.5]	12.05	14.00	74	1,400 [661]	42,500 [12.5]	3.68	28,400 [8.3]	2.68	9.00
	RCFL-H*4824 (-GPR-10?BRM?)	43,000 [12.6]	30,800 [9.0]	12,200 [3.6]	11.80	14.00	74	1,425 [672]	42,500 [12.5]	3.68	28,400 [8.3]	2.68	9.00
	RCFL-H*4824 (-GPR-12?ARM?)	43,000 [12.6]	30,950 [9.1]	12,050 [3.5]	12.05	14.00	74	1,400 [661]	42,500 [12.5]	3.68	28,400 [8.3]	2.68	9.00
	-HKL-HM4821 (RCSL-H*4821)	43,500 [12.7]	31,050 [9.1]	12,450 [3.6]	12.25	14.00	74	1,400 [661]	41,000 [12.0]	4.08	27,000 [7.9]	2.96	9.50
	-HLL-HM4821 (RCSL-H*4821)	43,500 [12.7]	31,100 [9.1]	12,400 [3.6]	12.35	14.00	74	1,400 [661]	41,000 [12.0]	4.08	27,000 [7.9]	2.96	9.50
043JEZ	-HSL-HM4221 (RCSL-H*4821) ①	42,500 [12.5]	30,250 [8.9]	12,250 [3.6]	11.50	13.00	74	1,400 [661]	43,500 [12.7]	3.68	28,600 [8.4]	2.64	9.00
	-HSL-HM4821 (RCSL-H*4821) ①	42,500 [12.5]	30,250 [8.9]	12,250 [3.6]	11.15	13.00	74	1,400 [661]	43,500 [12.7]	3.66	28,600 [8.4]	2.64	9.55
	RCFL-H*4821	42,000 [12.3]	29,750 [8.7]	12,250 [3.6]	10.50	13.00	74	1,400 [661]	43,500 [12.7]	3.60	28,800 [8.4]	2.64	9.00
	RCFL-H*4821 (-GFE-09?ZCM?)	42,500 [12.5]	30,300 [8.9]	12,200 [3.6]	11.10	13.00	74	1,400 [661]	43,500 [12.7]	3.70	28,400 [8.3]	2.66	9.50
	RCFL-H*4821 (-GGE-09?ZCM?)	42,500 [12.5]	30,300 [8.9]	12,200 [3.6]	11.20	13.50	74	1,400 [661]	43,000 [12.6]	3.70	28,400 [8.3]	2.68	9.50
	RCFL-H*4821 (-GGE-10?ZCM?)	42,500 [12.5]	30,300 [8.9]	12,200 [3.6]	11.10	13.00	74	1,400 [661]	43,500 [12.7]	3.70	28,400 [8.3]	2.66	9.50
	RCFL-H*4821 (-GJF-09?ZCM?)	42,500 [12.5]	30,300 [8.9]	12,200 [3.6]	11.25	13.50	74	1,400 [661]	43,000 [12.6]	3.70	28,200 [8.3]	2.68	9.50
	RCFL-H*4821 (-GJF-10?ZCM?)	42,500 [12.5]	30,300 [8.9]	12,200 [3.6]	11.15	13.00	74	1,400 [661]	43,500 [12.7]	3.70	28,400 [8.3]	2.68	9.50
	RCFL-H*4821 (-GLE-10?BRM?)	42,500 [12.5]	30,200 [8.8]	12,300 [3.6]	11.60	14.00	74	1,400 [661]	43,000 [12.6]	3.74	28,000 [8.2]	2.74	9.50
	RCFL-H*4821 (-GLR-07?BRQ?)	42,000 [12.3]	29,850 [8.7]	12,150 [3.6]	11.00	13.50	74	1,425 [672]	43,000 [12.6]	3.80	28,200 [8.3]	2.72	9.50
	RCFL-H*4821 (-GLR-10?BRM?)	42,000 [12.3]	29,850 [8.7]	12,150 [3.6]	11.00	13.50	74	1,375 [649]	43,000 [12.6]	3.80	28,000 [8.2]	2.74	9.50
	RCFL-H*4821 (RGLT-07?AME?)	42,000 [12.3]	29,550 [8.7]	12,450 [3.6]	11.00	13.00	74	1,350 [637]	43,500 [12.7]	3.72	28,400 [8.3]	2.66	9.50
	RCFL-H*4821 (RGLT-07?BRQ?)	43,000 [12.6]	31,050 [9.1]	11,950 [3.5]	11.00	13.50	74	1,450 [684]	43,000 [12.6]	3.76	28,200 [8.3]	2.70	9.50
	RCFL-H*4821 (RGLT-10?BRM?)	42,500 [12.5]	30,250 [8.9]	12,250 [3.6]	11.00	13.50	74	1,425 [672]	43,000 [12.6]	3.78	28,200 [8.3]	2.70	9.50
	RCFL-H*4821 (-GPE-07?BRQ?)	42,500 [12.5]	30,200 [8.8]	12,300 [3.6]	11.50	13.50	74	1,400 [661]	43,000 [12.6]	3.70	28,200 [8.3]	2.72	9.50
	RCFL-H*4821 (-GPE-10?BRM?)	42,500 [12.5]	30,200 [8.8]	12,300 [3.6]	11.50	13.50	74	1,400 [661]	43,000 [12.6]	3.70	28,200 [8.3]	2.72	9.50
	RCFL-H*4821 (-GPR-07?BRQ?)	42,000 [12.3]	29,850 [8.7]	12,150 [3.6]	11.00	13.50	74	1,400 [661]	43,000 [12.6]	3.80	28,200 [8.3]	2.72	9.50
	RCFL-H*4821 (-GPR-10?BRM?)	42,000 [12.3]	29,900 [8.8]	12,100 [3.5]	11.00	13.50	74	1,425 [672]	43,000 [12.6]	3.74	28,400 [8.3]	2.70	9.50
	RCFL-H*4821 (RGPT-07?AME?)	42,000 [12.3]	29,550 [8.7]	12,450 [3.6]	11.00	13.00	74	1,350 [637]	43,500 [12.7]	3.70	28,600 [8.4]	2.66	9.50
	RCFL-H*4821 (RGPT-07?BRQ?)	43,000 [12.6]	31,000 [9.1]	12,000 [3.5]	11.50	13.50	74	1,450 [684]	43,000 [12.6]	3.78	28,200 [8.3]	2.72	9.50

① Highest sales volume tested combination required by DOE test procedures.

[] Designates Metric Conversions

Performance Data AHRI Standard Conditions—UPNL- JEZ (Con't.)

Note: Only these combinations of indoor/outdoor units are approved and any other combinations should not be used.

Model Numbers		AHRI Cooling Performance							AHRI Heating Performance (70°F [21°C] Indoor)				
		80°F [26.5°C] DB/67°F [19.5°C] WB Indoor Air 95°F [35°C] DB Outdoor Air							Outdoor Air 47°F [8.5°C] DB/ 43°F [6°C] WB DOE High Temp.		Outdoor Air 17°F [-8.5°C] DB/ 15°F [-9.5°C] WB DOE Low Temp.		DOE Region IV HSPF
Outdoor Unit UPNL-	Indoor Coil and/or Air Handler	Total Capacity BTU/H [kW]	Net Sens. BTU/H [kW]	Net Latent BTU/H [kW]	EER	SEER	Snd. Rate dB	Indoor CFM [L/s]	DOE High Temp.		DOE Low Temp.		
									BTU/H [kW]	COP	BTU/H [kW]	COP	
Rev. 6/30/10	RCFL-H*4821 (RGPT-10?BRM?)	42,500 [12.5]	30,200 [8.8]	12,300 [3.6]	11.50	13.50	74	1,425 [672]	43,000 [12.6]	3.78	28,200 [8.3]	2.72	9.50
	RCFL-H*4821 (-GRM-09?ZAJ?)	41,500 [12.2]	29,500 [8.6]	12,000 [3.5]	10.80	13.00	74	1,400 [661]	43,500 [12.7]	3.60	28,600 [8.4]	2.64	9.00
043JEZ	RCFL-H*4821 (-GRM-10?ZAJ?)	41,500 [12.2]	29,500 [8.6]	12,000 [3.5]	10.70	13.00	74	1,425 [672]	43,500 [12.7]	3.60	28,800 [8.4]	2.62	9.00
	RCFL-H*4821 (-GRM-12?RAJ?)	42,000 [12.3]	29,900 [8.8]	12,100 [3.5]	11.05	13.00	74	1,425 [672]	43,500 [12.7]	3.60	28,400 [8.3]	2.66	9.00
	RCFL-H*4821 (-GTM-07?RBG?)	42,500 [12.5]	30,750 [9.0]	11,750 [3.4]	11.15	13.00	74	1,475 [696]	43,500 [12.7]	3.72	28,400 [8.3]	2.66	9.50
	RCFL-H*4821 (-GTM-09?ZAJ?)	42,500 [12.5]	30,300 [8.9]	12,200 [3.6]	11.20	13.50	74	1,400 [661]	43,500 [12.7]	3.74	28,400 [8.3]	2.68	9.50
	ROLA-070E04 (RCFL-H*4821)	42,500 [12.5]	30,250 [8.9]	12,250 [3.6]	11.00	13.50	74	1,375 [649]	43,000 [12.6]	3.78	28,200 [8.3]	2.72	9.50
	ROLA-115E05 (RCFL-H*4821)	42,500 [12.5]	30,250 [8.9]	12,250 [3.6]	11.00	13.50	74	1,400 [661]	43,000 [12.6]	3.78	28,200 [8.3]	2.72	9.50
	RCFL-H*4824	42,000 [12.3]	29,750 [8.7]	12,250 [3.6]	10.50	13.00	74	1,400 [661]	43,500 [12.7]	3.60	28,800 [8.4]	2.64	9.00
	RCFL-H*4824 (-GFE-09?ZCM?)	42,000 [12.3]	29,850 [8.7]	12,150 [3.6]	11.05	13.00	74	1,400 [661]	43,500 [12.7]	3.70	28,400 [8.3]	2.64	9.50
	RCFL-H*4824 (-GFE-12?RCM?)	42,500 [12.5]	30,550 [9.0]	11,950 [3.5]	11.25	13.50	74	1,450 [684]	43,000 [12.6]	3.70	28,400 [8.3]	2.68	9.50
	RCFL-H*4824 (-GGD-12?RCM?)	42,500 [12.5]	30,650 [9.0]	11,850 [3.5]	11.00	13.50	74	1,450 [684]	43,000 [12.6]	3.60	28,200 [8.3]	2.70	9.00
	RCFL-H*4824 (-GGE-09?ZCM?)	42,500 [12.5]	30,300 [8.9]	12,200 [3.6]	11.20	13.50	74	1,400 [661]	43,000 [12.6]	3.74	28,400 [8.3]	2.68	9.50
	RCFL-H*4824 (-GGE-10?ZCM?)	42,500 [12.5]	30,300 [8.9]	12,200 [3.6]	11.10	13.00	74	1,400 [661]	43,500 [12.7]	3.70	28,400 [8.3]	2.66	9.50
	RCFL-H*4824 (-GGE-12?RCM?)	42,500 [12.5]	30,200 [8.8]	12,300 [3.6]	11.50	13.50	74	1,375 [649]	43,000 [12.6]	3.74	28,000 [8.2]	2.72	9.50
	RCFL-H*4824 (-GJD-12?RCM?)	42,500 [12.5]	30,650 [9.0]	11,850 [3.5]	11.00	13.50	74	1,450 [684]	43,000 [12.6]	3.60	28,200 [8.3]	2.70	9.50
	RCFL-H*4824 (-GJF-09?ZCM?)	42,500 [12.5]	30,300 [8.9]	12,200 [3.6]	11.25	13.50	74	1,400 [661]	43,000 [12.6]	3.74	28,200 [8.3]	2.68	9.50
	RCFL-H*4824 (-GJF-10?ZCM?)	42,500 [12.5]	30,300 [8.9]	12,200 [3.6]	11.15	13.00	74	1,400 [661]	43,500 [12.7]	3.70	28,400 [8.3]	2.68	9.50
	RCFL-H*4824 (-GJF-12?RCM?)	42,500 [12.5]	30,200 [8.8]	12,300 [3.6]	11.55	13.50	74	1,375 [649]	43,000 [12.6]	3.80	28,000 [8.2]	2.72	9.50
	RCFL-H*4824 (-GLE-10?BRM?)	42,500 [12.5]	30,200 [8.8]	12,300 [3.6]	11.60	14.00	74	1,400 [661]	43,000 [12.6]	3.80	28,000 [8.2]	2.74	9.50
	RCFL-H*4824 (-GLE-12?ARM?)	42,500 [12.5]	30,200 [8.8]	12,300 [3.6]	11.60	14.00	74	1,425 [672]	43,000 [12.6]	3.80	28,000 [8.2]	2.74	9.50
	RCFL-H*4824 (-GLR-07?BRQ?)	42,000 [12.3]	29,850 [8.7]	12,150 [3.6]	11.00	13.50	74	1,425 [672]	43,000 [12.6]	3.80	28,200 [8.3]	2.72	9.50
	RCFL-H*4824 (-GLR-10?BRM?)	42,000 [12.3]	29,850 [8.7]	12,150 [3.6]	11.00	13.50	74	1,375 [649]	43,000 [12.6]	3.80	28,000 [8.2]	2.74	9.50
	RCFL-H*4824 (-GLR-12?ARM?)	42,000 [12.3]	29,850 [8.7]	12,150 [3.6]	11.00	13.50	74	1,425 [672]	43,000 [12.6]	3.80	28,200 [8.3]	2.72	9.50
	RCFL-H*4824 (RGLT-07?BRQ?)	43,000 [12.6]	31,050 [9.1]	11,950 [3.5]	11.00	13.50	74	1,450 [684]	43,000 [12.6]	3.76	28,200 [8.3]	2.70	9.50
	RCFL-H*4824 (RGLT-10?BRM?)	42,500 [12.5]	30,250 [8.9]	12,250 [3.6]	11.00	13.50	74	1,425 [672]	43,000 [12.6]	3.78	28,200 [8.3]	2.70	9.50
	RCFL-H*4824 (RGLT-12?ARM?)	43,000 [12.6]	30,650 [9.0]	12,350 [3.6]	11.50	14.00	74	1,375 [649]	43,000 [12.6]	3.82	28,000 [8.2]	2.74	9.50
	RCFL-H*4824 (-GPE-07?BRQ?)	42,500 [12.5]	30,250 [8.9]	12,250 [3.6]	11.45	13.50	74	1,400 [661]	43,000 [12.6]	3.74	28,200 [8.3]	2.72	9.50

① Highest sales volume tested combination required by DOE test procedures.

[] Designates Metric Conversions

Performance Data AHRI Standard Conditions—UPNL- JEZ (Con't.)

Note: Only these combinations of indoor/outdoor units are approved and any other combinations should not be used.

Model Numbers		AHRI Cooling Performance							AHRI Heating Performance (70°F [21°C] Indoor)				
		80°F [26.5°C] DB/67°F [19.5°C] WB Indoor Air 95°F [35°C] DB Outdoor Air							Outdoor Air 47°F [8.5°C] DB/ 43°F [6°C] WB DOE High Temp.		Outdoor Air 17°F [-8.5°C] DB/ 15°F [-9.5°C] WB DOE Low Temp.		DOE Region IV HSPF
		Total Capacity BTU/H [kW]	Net Sens. BTU/H [kW]	Net Latent BTU/H [kW]	EER	SEER	Snd. Rate dB	Indoor CFM [L/s]	BTU/H [kW]	COP	BTU/H [kW]	COP	
Outdoor Unit UPNL-	Indoor Coil and/or Air Handler												
043JEZ	Rev. 6/30/10 RCFL-H*4824 (-GPE-10?BRM?)	42,500 [12.5]	30,200 [8.8]	12,300 [3.6]	11.50	13.50	74	1,400 [661]	43,000 [12.6]	3.74	28,200 [8.3]	2.72	9.50
	RCFL-H*4824 (-GPE-12?ARM?)	42,500 [12.5]	30,200 [8.8]	12,300 [3.6]	11.60	14.00	74	1,425 [672]	43,000 [12.6]	3.80	28,000 [8.2]	2.74	9.50
	RCFL-H*4824 (-GPR-07?BRQ?)	42,000 [12.3]	29,850 [8.7]	12,150 [3.6]	11.00	13.50	74	1,400 [661]	43,000 [12.6]	3.80	28,200 [8.3]	2.72	9.50
	RCFL-H*4824 (-GPR-10?BRM?)	42,000 [12.3]	29,900 [8.8]	12,100 [3.5]	11.00	13.50	74	1,425 [672]	43,500 [12.7]	3.74	28,400 [8.3]	2.70	9.50
	RCFL-H*4824 (-GPR-12?ARM?)	42,000 [12.3]	29,850 [8.7]	12,150 [3.6]	11.00	13.50	74	1,400 [661]	43,000 [12.6]	3.80	28,200 [8.3]	2.72	9.50
	RCFL-H*4824 (RGPT-07?BRQ?)	43,000 [12.6]	31,000 [9.1]	12,000 [3.5]	11.50	13.50	74	1,450 [684]	43,000 [12.6]	3.78	28,200 [8.3]	2.72	9.50
	RCFL-H*4824 (RGPT-10?BRM?)	42,500 [12.5]	30,200 [8.8]	12,300 [3.6]	11.50	13.50	74	1,425 [672]	43,000 [12.6]	3.78	28,200 [8.3]	2.72	9.50
	RCFL-H*4824 (RGPT-12?ARM?)	43,000 [12.6]	30,650 [9.0]	12,350 [3.6]	11.50	14.00	74	1,375 [649]	43,000 [12.6]	3.84	28,000 [8.2]	2.74	9.50
	RCFL-H*4824 (-GRM-09?ZAJ?)	41,500 [12.2]	29,500 [8.6]	12,000 [3.5]	10.75	13.00	74	1,400 [661]	43,500 [12.7]	3.80	28,600 [8.4]	2.62	9.00
	RCFL-H*4824 (-GRM-10?ZAJ?)	41,500 [12.2]	29,500 [8.6]	12,000 [3.5]	10.70	13.00	74	1,425 [672]	43,500 [12.7]	3.60	28,800 [8.4]	2.62	9.00
	RCFL-H*4824 (-GRM-12?RAJ?)	42,000 [12.3]	29,900 [8.8]	12,100 [3.5]	11.05	13.00	74	1,425 [672]	43,500 [12.7]	3.60	28,400 [8.3]	2.66	9.00
	RCFL-H*4824 (-GTM-07?RBG?)	42,500 [12.5]	30,750 [9.0]	11,750 [3.4]	11.15	13.00	74	1,475 [696]	43,500 [12.7]	3.72	28,400 [8.3]	2.66	9.50
	RCFL-H*4824 (-GTM-09?ZAJ?)	42,500 [12.5]	30,300 [8.9]	12,200 [3.6]	11.20	13.50	74	1,400 [661]	43,500 [12.7]	3.74	28,400 [8.3]	2.68	9.50
	RCFL-H*4824 (-GTM-10?RBJ?)	42,500 [12.5]	30,250 [8.9]	12,250 [3.6]	11.35	13.50	74	1,425 [672]	43,000 [12.6]	3.78	28,200 [8.3]	2.70	9.50
	ROLA-070E04 (RCFL-H*4824)	42,500 [12.5]	30,250 [8.9]	12,250 [3.6]	11.00	13.50	74	1,375 [649]	43,000 [12.6]	3.78	28,200 [8.3]	2.72	9.50
	ROLA-115E05 (RCFL-H*4824)	42,500 [12.5]	30,250 [8.9]	12,250 [3.6]	11.00	13.50	74	1,400 [661]	43,000 [12.6]	3.78	28,200 [8.3]	2.70	9.50
	-BHP-24 (RCHL-48A1)	40,500 [11.9]	28,000 [8.2]	12,500 [3.7]	11.50	14.00	74	1,400 [661]	44,500 [13.0]	3.60	28,800 [8.4]	2.66	9.00
	-HKL-HM4821 (RCSL-H*4821)	42,500 [12.5]	30,300 [8.9]	12,200 [3.6]	11.50	14.00	74	1,400 [661]	43,000 [12.6]	3.50	28,000 [8.2]	2.74	9.50
	-HLL-HM4821 (RCSL-H*4821)	42,500 [12.5]	30,250 [8.9]	12,250 [3.6]	11.50	14.00	74	1,400 [661]	43,000 [12.6]	3.50	28,000 [8.2]	2.74	9.50
	049JEZ	-HSL-HM4821 (RCSL-H*4821) ①	46,500 [13.6]	32,850 [9.6]	13,650 [4.0]	10.50	13.00	76	1,600 [755]	47,500 [13.9]	3.64	31,600 [9.3]	2.66
RCFL-H*4821		45,000 [13.2]	31,350 [9.2]	13,650 [4.0]	10.50	13.00	76	1,475 [696]	47,500 [13.9]	3.64	31,600 [9.3]	2.68	9.00
RCFL-H*4821 (-GLE-10?BRM?)		47,000 [13.8]	34,050 [10.0]	12,950 [3.8]	11.15	13.00	76	1,600 [755]	47,000 [13.8]	3.70	31,200 [9.1]	2.72	9.00
RCFL-H*4821 (-GPE-07?BRQ?)		47,000 [13.8]	34,100 [10.0]	12,900 [3.8]	10.90	13.00	76	1,600 [755]	47,500 [13.9]	3.66	31,400 [9.2]	2.70	9.00
RCFL-H*4821 (-GPE-10?BRM?)		47,000 [13.8]	34,250 [10.0]	12,750 [3.7]	11.00	13.00	76	1,625 [767]	47,500 [13.9]	3.66	31,400 [9.2]	2.68	9.00
RCFL-H*4821 (RGPT-07?BRQ?)		47,500 [13.9]	34,100 [10.0]	13,400 [3.9]	11.50	13.50	76	1,550 [731]	47,000 [13.8]	3.78	31,000 [9.1]	2.76	9.00
RCFL-H*4821 (RGPT-10?BRM?)		47,000 [13.8]	34,400 [10.1]	12,600 [3.7]	10.90	13.00	76	1,650 [779]	47,500 [13.9]	3.64	31,600 [9.3]	2.66	9.00
RCFL-H*4821 (-GTM-07?RBG?)		46,500 [13.6]	32,750 [9.6]	13,750 [4.0]	11.05	13.00	76	1,475 [696]	47,000 [13.8]	3.70	31,200 [9.1]	2.72	9.00
ROLA-115E05 (RCFL-H*4821)		46,500 [13.6]	32,800 [9.6]	13,700 [4.0]	10.90	13.00	76	1,500 [708]	47,000 [13.8]	3.68	31,400 [9.2]	2.70	9.00

① Highest sales volume tested combination required by DOE test procedures.

[] Designates Metric Conversions

Performance Data AHRI Standard Conditions—UPNL- JEZ (Con't.)

Note: Only these combinations of indoor/outdoor units are approved and any other combinations should not be used.

Model Numbers		AHRI Cooling Performance							AHRI Heating Performance (70°F [21°C] Indoor)					
		80°F [26.5°C] DB/67°F [19.5°C] WB Indoor Air 95°F [35°C] DB Outdoor Air							Outdoor Air 47°F [8.5°C] DB/ 43°F [6°C] WB DOE High Temp.		Outdoor Air 17°F [-8.5°C] DB/ 15°F [-9.5°C] WB DOE Low Temp.		DOE Region IV HSPF	
		Total Capacity BTU/H [kW]	Net Sens. BTU/H [kW]	Net Latent BTU/H [kW]	EER	SEER	Snd. Rate dB	Indoor CFM [L/s]	BTU/H [kW]	COP	BTU/H [kW]	COP		
Outdoor Unit UPNL-	Indoor Coil and/or Air Handler													
Rev. 6/30/10	RCFL-H*4824	45,000 [13.2]	31,350 [9.2]	13,650 [4.0]	10.50	13.00	76	1,475 [696]	47,500 [13.9]	3.64	31,600 [9.3]	2.68	9.00	
	RCFL-H*4824 (-GGE-12?RCM?)	47,000 [13.8]	33,900 [9.9]	13,100 [3.8]	10.95	13.00	76	1,575 [743]	47,500 [13.9]	3.68	31,400 [9.2]	2.70	9.00	
049JEZ	RCFL-H*4824 (-GLE-10?BRM?)	47,000 [13.8]	34,050 [10.0]	12,950 [3.8]	11.15	13.00	76	1,600 [755]	47,000 [13.8]	3.70	31,200 [9.1]	2.72	9.00	
	RCFL-H*4824 (-GLE-12?ARM?)	47,000 [13.8]	34,050 [10.0]	12,950 [3.8]	11.10	13.00	76	1,600 [755]	47,000 [13.8]	3.70	31,200 [9.1]	2.72	9.00	
	RCFL-H*4824 (RGLT-12?ARM?)	47,500 [13.9]	34,900 [10.2]	12,600 [3.7]	11.00	13.00	76	1,650 [779]	47,500 [13.9]	3.66	31,600 [9.3]	2.68	9.00	
	RCFL-H*4824 (-GPE-07?BRQ?)	47,000 [13.8]	34,100 [10.0]	12,900 [3.8]	10.90	13.00	76	1,600 [755]	47,500 [13.9]	3.66	31,400 [9.2]	2.70	9.00	
	RCFL-H*4824 (-GPE-10?BRM?)	47,000 [13.8]	34,250 [10.0]	12,750 [3.7]	11.00	13.00	76	1,625 [767]	47,500 [13.9]	3.66	31,400 [9.2]	2.68	9.00	
	RCFL-H*4824 (-GPE-12?ARM?)	47,500 [13.9]	34,700 [10.2]	12,800 [3.8]	11.15	13.00	76	1,625 [767]	47,000 [13.8]	3.70	31,200 [9.1]	2.70	9.00	
	RCFL-H*4824 (-GPR-07?BRQ?)	47,000 [13.8]	34,200 [10.0]	12,800 [3.8]	11.05	13.00	76	1,625 [767]	47,000 [13.8]	3.68	31,400 [9.2]	2.70	9.00	
	RCFL-H*4824 (RGPT-07?BRQ?)	47,500 [13.9]	34,100 [10.0]	13,400 [3.9]	11.50	13.50	76	1,550 [731]	47,000 [13.8]	3.78	31,000 [9.1]	2.76	9.00	
	RCFL-H*4824 (RGPT-10?BRM?)	47,000 [13.8]	34,400 [10.1]	12,600 [3.7]	10.90	13.00	76	1,650 [779]	47,500 [13.9]	3.64	31,600 [9.3]	2.66	9.00	
	RCFL-H*4824 (RGPT-12?ARM?)	47,500 [13.9]	34,900 [10.2]	12,600 [3.7]	11.00	13.00	76	1,650 [779]	47,500 [13.9]	3.64	31,600 [9.3]	2.68	9.00	
	RCFL-H*4824 (-GTM-07?RBG?)	46,500 [13.6]	32,750 [9.6]	13,750 [4.0]	11.05	13.00	76	1,475 [696]	47,000 [13.8]	3.70	31,200 [9.1]	2.72	9.00	
	ROLA-115E05 (RCFL-H*4824)	46,500 [13.6]	32,800 [9.6]	13,700 [4.0]	10.85	13.00	76	1,500 [708]	47,500 [13.9]	3.68	31,400 [9.2]	2.70	9.00	
	-BHP-24 (RCHL-48A1)	44,500 [13.0]	31,100 [9.1]	13,400 [3.9]	11.00	13.00	76	1,575 [743]	48,500 [14.2]	3.68	31,800 [9.3]	2.60	9.00	
	-HKL-HM4821 (RCSL-H*4821)	47,500 [13.9]	34,350 [10.1]	13,150 [3.9]	11.00	13.50	76	1,575 [743]	47,000 [13.8]	3.74	31,000 [9.1]	2.74	9.50	
	-HLL-HM4821 (RCSL-H*4821)	47,500 [13.9]	34,500 [10.1]	13,000 [3.8]	11.00	13.50	76	1,600 [755]	47,000 [13.8]	3.74	31,000 [9.1]	2.74	9.50	
	-HSL-HM4824 (RCSL-H*4821)	46,500 [13.6]	32,850 [9.6]	13,650 [4.0]	10.50	13.00	76	1,600 [755]	47,500 [13.9]	3.64	31,600 [9.3]	2.66	9.00	
	-HKL-HM4824 (RCSL-H*4824)	48,000 [14.1]	35,100 [10.3]	12,900 [3.8]	11.50	14.00	76	1,625 [767]	46,500 [13.6]	3.80	30,800 [9.0]	2.78	9.50	
	-HLL-HM4824 (RCSL-H*4824)	48,000 [14.1]	35,100 [10.3]	12,900 [3.8]	11.50	14.00	76	1,625 [767]	46,500 [13.6]	3.80	30,800 [9.0]	2.78	9.50	
	060JEZ	-HLL-HM6024 (RCSL-H*6024) ①	60,500 [17.7]	43,100 [12.6]	17,400 [5.1]	11.15	13.00	74	1,800 [849]	58,500 [17.1]	3.66	38,000 [11.1]	2.72	9.00
		-HKL-HM6024 (RCSL-H*6024)	60,500 [17.7]	43,100 [12.6]	17,400 [5.1]	11.15	13.00	74	1,800 [849]	58,500 [17.1]	3.66	38,000 [11.1]	2.72	9.00

① Highest sales volume tested combination required by DOE test procedures.

[] Designates Metric Conversions

Electrical and Physical Data: UPNL- JEZ

Model Number UPNL-	ELECTRICAL							PHYSICAL					
	Phase Frequency (Hz) Voltage (Volts)	Compressor		Fan Motor Full Load Amperes (FLA)	Minimum Circuit Capacity Amperes	Fuse or HACR Circuit Breaker		Outdoor Coil			Refrig. Per Circuit Oz. [g]	Weight	
		Rated Load Amperes (RLA)	Locked Rotor Amperes (LRA)			Minimum Amperes	Maximum Amperes	Face Area Sq. Ft. [m ²]	No. Rows	CFM [L/s]		Net Lbs. [kg]	Shipping Lbs. [kg]
Rev. 6/30/10													
024JEZ	1-60-208/230	12.8/12.8	58.3	0.6	17/17	20/20	25/25	8.18 [0.76]	1	1925 [908]	86 [2438]	163 [73.9]	173 [78.5]
030JEZ	1-60-208/230	14.1/14.1	73	0.8	19/19	25/25	30/30	20.13 [1.87]	1	2650 [1251]	133 [3771]	208 [94.3]	218 [98.9]
031JEZ	1-60-208/230	14.1/14.1	73	0.6	20/20	25/25	30/30	13 [1.21]	1	1925 [908]	101 [2863]	164.5 [74.6]	174.5 [79.2]
036JEZ	1-60-208/230	17.9/17.9	112	1.2	24/24	30/30	40/40	23.01 [2.14]	1	3575 [1687]	145 [4111]	254.5 [115.4]	264.5 [120]
037JEZ	1-60-208/230	16.7/16.7	79	1.3	23/23	30/30	35/35	20.1 [1.87]	1	3575 [1687]	149 [4224]	229 [103.9]	239 [108.4]
042JEZ	1-60-208/230	20.5/20.5	109	1.2	27/27	35/35	45/45	23.01 [2.14]	1	3575 [1687]	160 [4536]	265 [120.2]	275 [124.7]
043JEZ	1-60-208/230	20.5/20.5	109	1.2	27/27	35/35	45/45	20.1 [1.87]	1	2650 [1251]	168 [4763]	227 [103]	237 [107.5]
049JEZ	1-60-208/230	21.8/21.8	117	1.2	29/29	35/35	50/50	20.1 [1.87]	1	3575 [1687]	157 [4451]	229 [103.9]	239 [108.4]
060JEZ	1-60-208/230	26.3/26.3	134	1.2	35/35	45/45	60/60	23.01 [2.14]	1	3350 [1581]	242 [6861]	268 [121.6]	278 [126.1]

Unit Dimensions

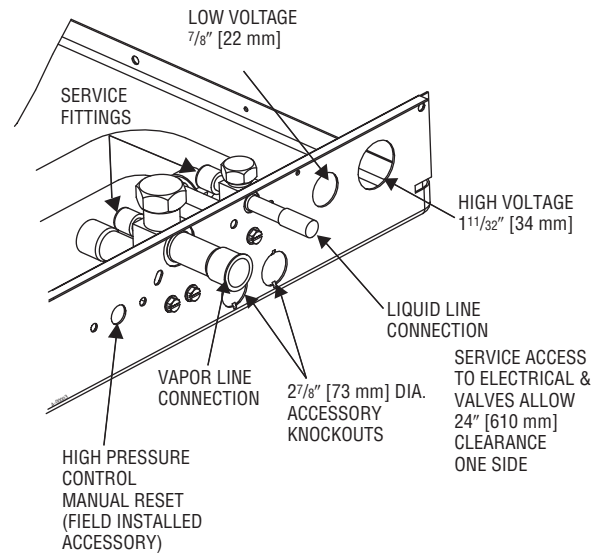
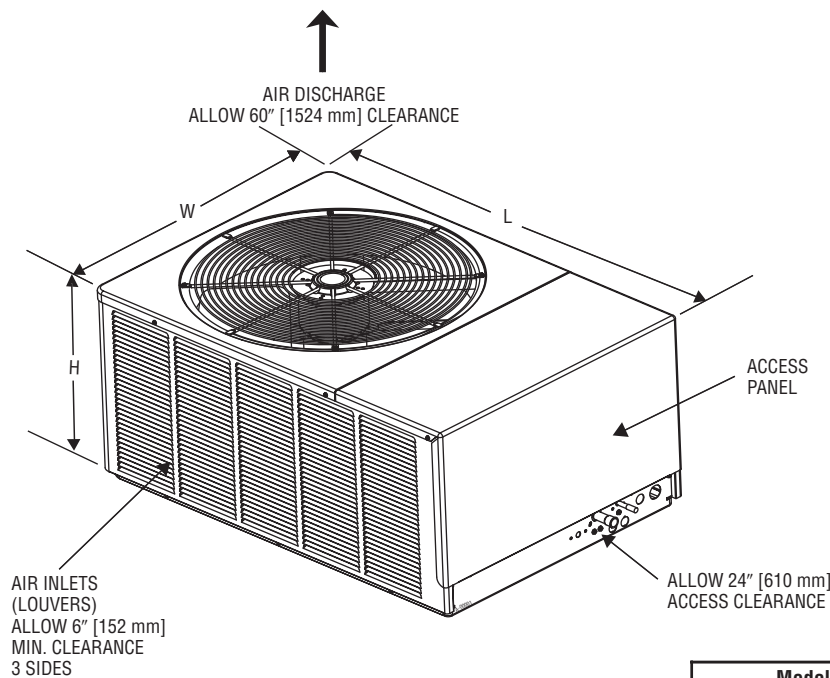

Model Number UPNL-	Height "H" (Inches) [mm]	Length "L" (Inches) [mm]	Width "W" (Inches) [mm]
024JEZ/030JEZ/031JEZ	19 [482]	40 ¹ / ₂ [1028]	27 ⁵ / ₈ [701]
036JEZ/037JEZ/043JEZ/049JEZ	29 [736]	44 ³ / ₈ [1127]	31 ¹ / ₂ [800]
060JEZ	33 [838]	44 ³ / ₈ [1127]	31 ¹ / ₂ [800]

[] Designates Metric Conversions

NOTES

NOTES

Heat Pump Refrigerant Line Size Information

System Capacity	Line Size Connection Size (Inch I.D.) [mm]	Line Size (Inch O.D.) [mm]	Liquid Line Sizing (R-410A)					
			Outdoor Unit Above or Below Indoor Coil (Heat Pumps Only)					
			Total Equivalent Length—Feet [m]					
			25 [7.62]	50 [15.24]	75 [22.86]	100 [30.48]	125 [38.10]	150 [45.72]
Maximum Vertical Separation—Feet [m]								
2 Ton	3/8" [9.53]	1/4 [6.35]	23 [7.01]	N/A	N/A	N/A	N/A	N/A
		5/16 [7.94]	25 [7.62]	36 [10.97]	29 [8.84]	23 [7.01]	16 [4.88]	9 [2.74]
		3/8* [9.53]	25 [7.62]	50 [15.24]	72 [21.95]	70 [21.34]	68 [20.73]	65 [19.81]
2 1/2 Ton	3/8" [9.53]	1/4 [6.35]	25 [7.62]	N/A	N/A	N/A	N/A	N/A
		5/16 [7.94]	25 [7.62]	49 [14.94]	38 [11.58]	27 [8.23]	17 [5.18]	6 [1.83]
		3/8* [9.53]	25 [7.62]	50 [15.24]	68 [20.73]	65 [19.81]	62 [18.90]	58 [17.68]
3 Ton	3/8" [9.53]	5/16 [7.94]	25 [7.62]	50 [15.24]	37 [11.28]	22 [6.71]	7 [2.13]	N/A
		3/8* [9.53]	25 [7.62]	50 [15.24]	68 [20.73]	63 [19.20]	58 [17.68]	53 [16.15]
3 1/2 Ton	3/8" [9.53]	5/16 [7.94]	25 [7.62]	23 [7.01]	4 [1.22]	N/A	N/A	N/A
		3/8* [9.53]	25 [7.62]	50 [15.24]	43 [13.11]	36 [10.97]	30 [9.14]	24 [7.32]
4 Ton	3/8" [9.53]	3/8* [9.53]	25 [7.62]	46 [14.02]	38 [11.58]	30 [9.14]	22 [6.71]	15 [4.57]
		1/2 [12.7]	25 [7.62]	50 [15.24]	56 [17.07]	55 [16.76]	53 [16.15]	52 [15.85]
5 Ton	3/8" [9.53]	3/8* [9.53]	25 [7.62]	50 [15.24]	56 [17.07]	44 [13.41]	32 [9.75]	20 [6.10]
		1/2 [12.7]	25 [7.62]	50 [15.24]	75 [22.86]	81 [24.69]	79 [24.08]	76 [23.16]

NOTES: *Standard line size
N/A = Application not recommended.

Suction Line Length/Size versus Capacity Multiplier (R-410A)							
Unit Size		2 Ton	2 1/2 Ton	3 Ton	3 1/2 Ton	4 Ton	5 Ton
Suction Line Connection Size		3/4" [19.05] I.D.			7/8" [22.23] I.D.		
Suction Line Run—Feet [m]		5/8" [15.88 mm] O.D. Opt. 3/4" [19.05 mm] O.D. Std.*	5/8" [15.88 mm] O.D. Opt. 3/4" [19.05 mm] O.D. Std.* 7/8" [22.23 mm] O.D. Opt.	3/4" [19.05 mm] O.D. Opt. 7/8" [22.23 mm] O.D. Std.*		7/8" [22.23 mm] O.D. Opt. 1 1/8" [28.58 mm] O.D. Std.*	
25' [7.62]	Optional Standard Optional	1.00 1.00 —	1.00 1.00 1.00	1.00 1.00 —	1.00 1.00 —	1.00 1.00 —	1.00 1.00 —
50' [15.24]	Optional Standard Optional	0.98 0.99 —	0.96 0.98 0.99	0.98 0.99 —	0.99 0.99 —	0.99 0.99 —	0.99 0.99 —
100' [30.48]	Optional Standard Optional	0.95 0.96 —	0.94 0.96 0.97	0.96 0.97 —	0.96 0.98 —	0.96 0.98 —	0.97 0.98 —
150' [45.72]	Optional Standard Optional	0.92 0.94 —	0.91 0.93 0.95	0.94 0.95 —	0.94 0.96 —	0.95 0.96 —	0.94 0.97 —

NOTES: *Standard line size [] Designates Metric Conversions
Note: Using suction line larger than shown in chart will result in poor oil return and is not recommended.

BEFORE PURCHASING THIS APPLIANCE, READ IMPORTANT ENERGY COST AND EFFICIENCY INFORMATION AVAILABLE FROM YOUR RETAILER.

GENERAL TERMS OF LIMITED WARRANTY

Ruud will furnish a replacement for any part of this product which fails in normal use and service within the applicable period stated, in accordance with the terms of the limited warranty.

For Complete Details of the Limited Warranty, Including Applicable Terms and Conditions, See Your Local Installer or Contact the Manufacturer for a Copy.

Compressor
JEZ Models Ten (10) Years
Any Other Part Ten (10) Years

UPNL- JEZ Conditional Replacement Warranty:

Ruud will provide a replacement model (if an exact replacement is not available, an equivalent product will be provided) to the original purchaser if the compressor fails within 5 years (providing the unit is installed with a new Ruud Air Handler OR Ruud Indoor Coil with a Ruud Gas Furnace, and is properly matched as specified by Ruud as listed in the Air Conditioning Institute (AHRI) published rating, and if additional conditions are satisfied. See product warranty card for additional information.

Before proceeding with installation, refer to installation instructions packaged with each model, as well as complying with all Federal, State, Provincial, and Local codes, regulations, and practices.

**Ruud Heating,
Cooling and
Water Heating**

P.O. Box 17010, Fort Smith, AR 72917



"In keeping with its policy of continuous progress and product improvement, Ruud reserves the right to make changes without notice."