

Commercial Air Handler

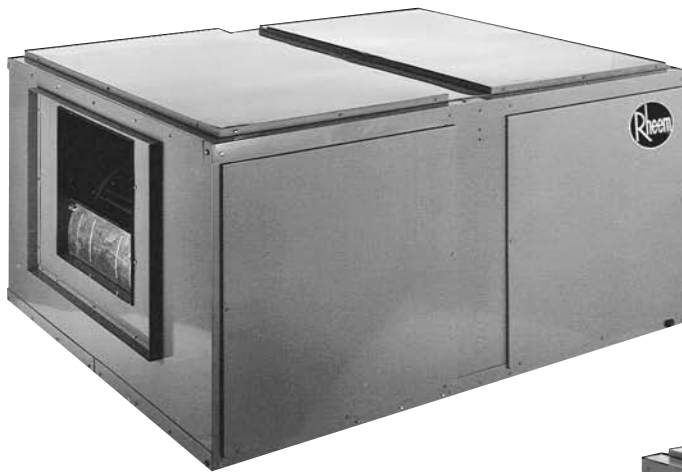

**7.5 & 10 TON MODEL
[26 & 35 kW]**

**15 & 20 TON MODEL
[53 & 70 kW]**



7.5 THROUGH 20 NOMINAL TON UNITS
[26 THROUGH 70 kW]
RHGG-090, 120, 180, 240



TABLE OF CONTENTS

Standard Unit Features	2	Component Air Resistance	11
Model Identification	2	Blower Performance Curves	11-14
Component Location	3	Evaporator Performance Data	15 & 16
Unit Dimensions	4	Electrical Data Table	17
Physical Data Table	5	Typical Wiring Connections	18
Drive Package Data	6	Accessories	18-23
Performance Data—Dual Straight Cool Condensing Units with Air Handler	7	Piping	24
Indoor Blower Performance Data	8-10	Guide Specifications	25
		Limited Warranty	25

MODEL NUMBER IDENTIFICATION

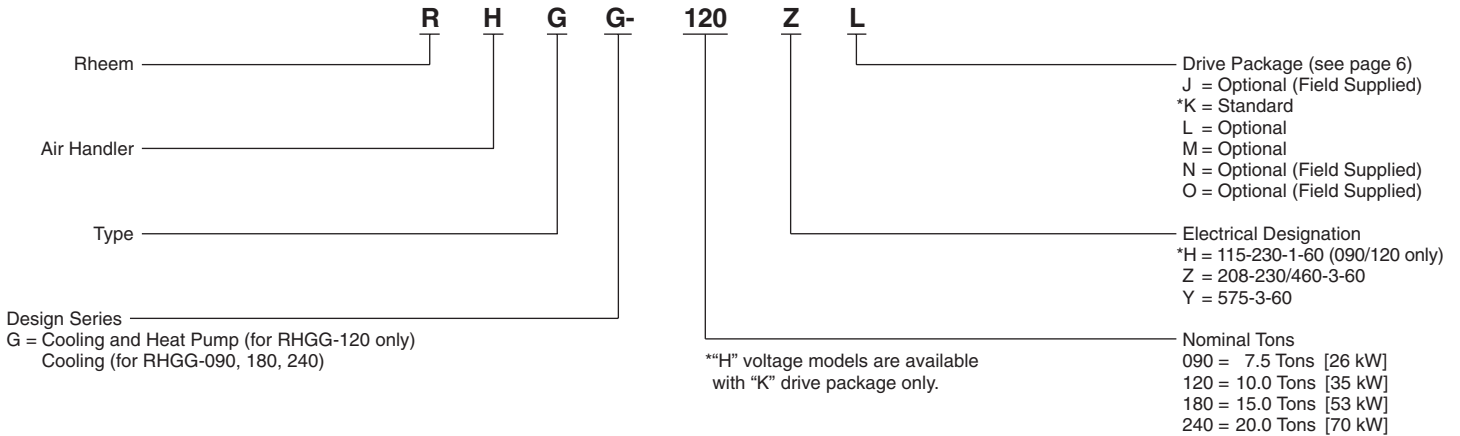

UNIT FEATURES

CABINET—Powder coat painted. Matching discharge plenums and decorative supply and return air grilles are available for use when units are to be installed within conditioned space.

MOTOR—Inherently protected motors are mounted inside of insulated cabinet to reduce motor noise and provide a neat looking installation. A choice of motor horsepower and drive combinations are available to allow you to meet specified CFM at various static pressures up to 2" [.498 kPa] external static pressure. Motors and mounts in 15 ton [53 kW] and 20 ton [70 kW] units may be relocated in field to opposite side of blower scroll for accessibility.

LOW PROFILE—Allows for horizontal installation in most standard drop ceiling applications, and the movement of units through most standard doorways for addition or replacement work.

THERMAL EXPANSION VALVES—Standard all models.

FILTERS—One inch [25 mm] throwaway filters are standard, but filter racks are designed to accept either one inch [25 mm] or two inch [51 mm] filters.

EVAPORATOR COIL—Two circuit, interlaced row split coils are constructed with copper tubes and aluminum fins mechanically bonded to the tubes for maximum heat transfer capabilities. All coil assemblies are leak tested up to 450 PSIG [3100 kPa] internal pressure prior to installation into units.

REFRIGERANT CONNECTIONS—Field piping connections are made through a fixed post between two side access panels on either side of the unit. Allows flexibility to meet most field

conditions as well as full accessibility after the installation is complete. Units may be used with two straight cool condensing units or single circuit manifolded in the field using the copper fittings shipped with each unit. The RHGG Air Handler has not been tested, rated or certified to operate with dual remote heat pumps.

DRAIN PAN—The galvanized steel drain pan is designed to trap condensate in either vertical or horizontal installations. Condensate drain connections are located on both sides of the unit allowing complete flexibility to meet most field conditions.

SERVICE ACCESS—Two removable panels on top and each side of the unit are easily removed for access to motors, blowers, sheaves, and filters.

HORIZONTAL OR VERTICAL—All models are designed for either application and can be installed in either position as supplied from the factory.

TESTING—All units are run tested at the factory prior to shipment. Units are shipped with a holding charge of nitrogen.

HEAT PUMP—The RHGG-120 Air Handler is designed for heat pump and air conditioning applications. It has two TX valves with internal check valves that allow reverse flow to occur, providing superior control during heating and cooling cycles. RHGG-120 Air Handler has been rated and certified to operate with 7.5 ton [26 kW] and 10 ton [35 kW] condensing units and 7.5 ton [26 kW] and 10 ton [35 kW] remote heat pumps. A 7.5 ton [26 kW] heat pump air handler is **NOT** available.

COMPONENT LOCATION

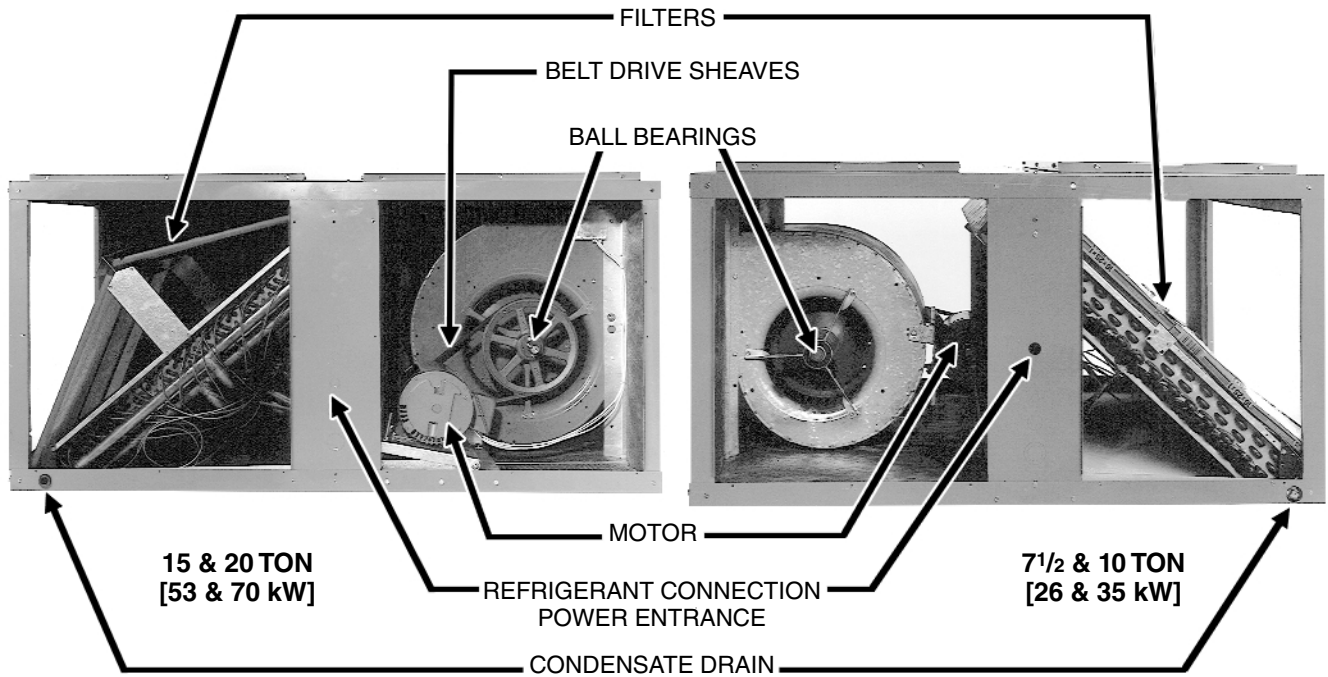

15 ton [53 kW] & 20 ton [70 kW] unit with side panel removed for blower and air filter access.

7 1/2 ton [26 kW] & 10 ton [35 kW] unit with side panel removed for coil connections and air filter access.

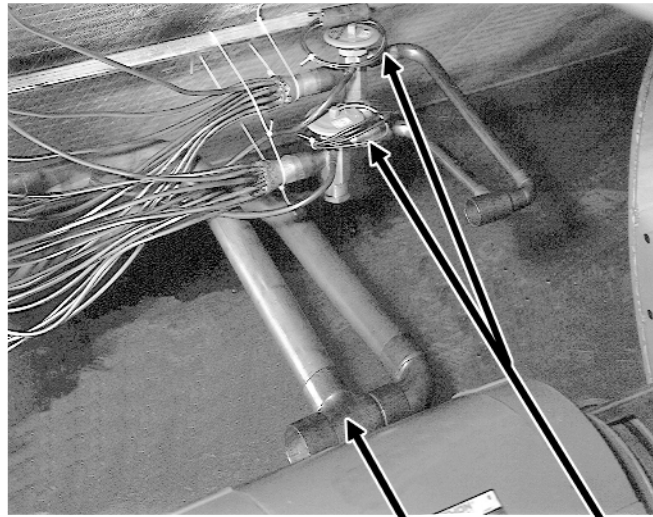

RHGG-
7 1/2-20 TON
[26-70 kW]

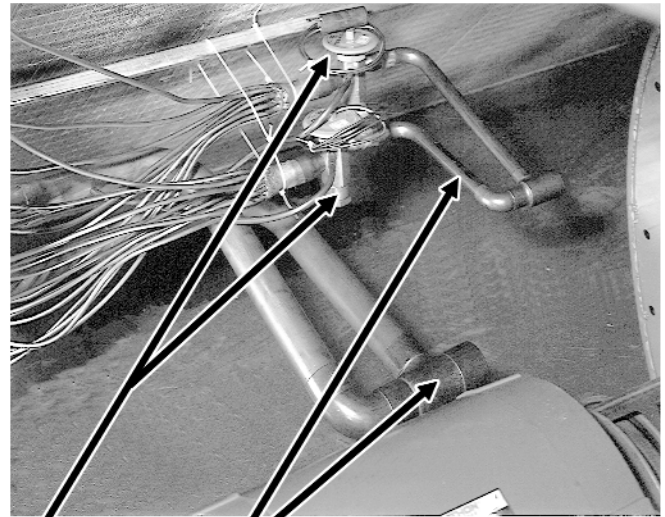

RHGG-
7 1/2-20 TON
[26-70 kW]

TX VALVES
SINGLE CIRCUIT MANIFOLD
REFRIGERANT CONNECTION
EITHER SIDE

[] Designates Metric Conversions

UNIT DIMENSIONS

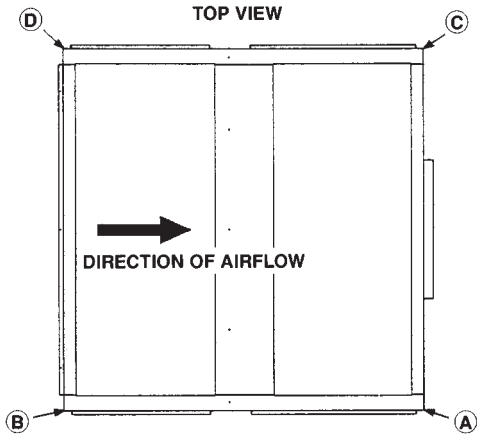

RETURN AIR OPENINGS = 47³/₈" [1203] WIDTH x 19⁷/₈" [505] HEIGHT

7 1/2 AND 10 NOMINAL TONS [26 AND 35 kW]

MODEL	REFRIGERANT STUB SIZES, IN. [mm]			
	DUAL LIQ.	DUAL SUC.	SINGLE LIQ.	SINGLE SUC.
090	1/2, 1/2 [13, 13]	7/8, 7/8 [22, 22]	1/2 [13]	1 1/8 [29]
120	1/2, 1/2 [13, 13]	7/8, 7/8 [22, 22]	5/8 [16]	1 3/8 [35]

MODEL	CORNER WEIGHTS, LBS. [kg]				TOTAL WEIGHT
	A	B	C	D	
090	88 [40]	78 [35]	87 [39]	77 [35]	330 [150]
120	93 [42]	82 [37]	92 [42]	80 [36]	347 [157]

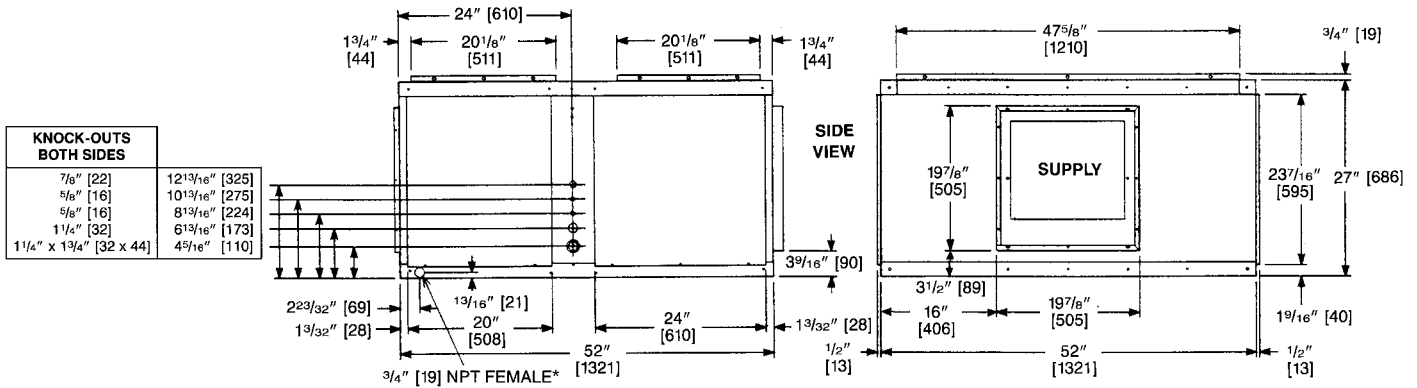

*Drain connections are provided on both sides of the drain pan. The drain can be connected to either side of the drain pan, but not both. The drain must be trapped.

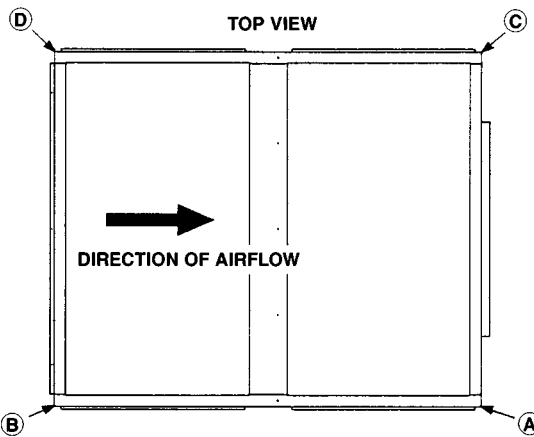

RETURN AIR OPENINGS = 55 1/2" [1410] WIDTH x 30 9/16" [776] HEIGHT

15 AND 20 NOMINAL TONS [53 & 70 kW]

MODEL	REFRIGERANT STUB SIZES, IN. [mm]			
	DUAL LIQ.	DUAL SUC.	SINGLE LIQ.	SINGLE SUC.
180	1/2, 1/2 [13, 13]	1 1/8, 1 1/8 [29, 29]	5/8 [16]	1 5/8 [41]
240	5/8, 5/8 [16, 16]	1 3/8, 1 3/8 [35, 35]	7/8 [22]	1 5/8 [41]

MODEL	CORNER WEIGHTS, LBS. [kg]				TOTAL WEIGHT
	A	B	C	D	
180	144 [65]	127 [58]	117 [53]	105 [48]	495 [225]
240	159 [72]	142 [64]	129 [59]	115 [52]	545 [247]

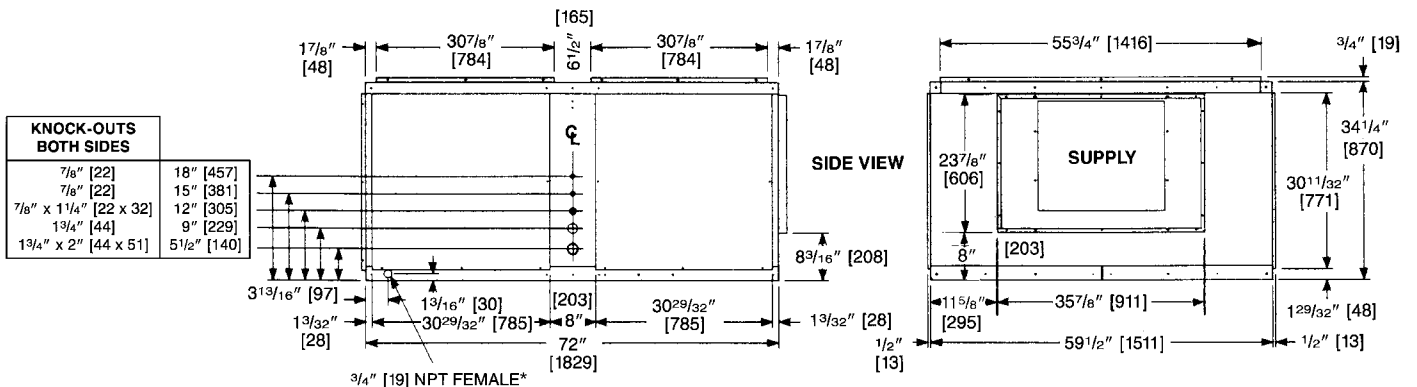

*Drain connections are provided on both sides of the drain pan. The drain can be connected to either side of the drain pan, but not both. The drain must be trapped.

PHYSICAL DATA TABLE

ITEM		MODEL NO. RHGG-			
		090	120	180	240
Nominal Size tons [kW]		7.5 [26]	10 [35]	15 [53]	20 [70]
Nominal CFM [L/s] @ Rated E.S.P., in. [kPa] of water		3000 @ .25 [1416 @ .062]	3000 @ .25 [1416 @ .062] 4000 @ .30 [1888 @ .075]	6000 @ .35 [2832 @ .087]	8000 @ .40 [3776 @ .099]
MOTOR	Standard— 3450 RPM [W] 1 Ø 1725 RPM [W] 3 Ø	1 HP [766] 1 HP [766]	2 HP [1491] 1½ HP [1119]	— 2 HP [1491]	— 5 HP [3729]
	Optional— 1725 RPM [W] 3 Ø	1½ HP [1119]	2 HP, 3 HP [1491, 2237]	3 HP, 5 HP [2237, 3729]	7½ HP [5593]
Blower Size—diameter & width, in. [mm]		12 x 12 [305 x 305]	12 x 12 [305 x 305]	18 x 15 [457 x 381]	18 x 18 [457 x 457]
Blower Shaft Size (diameter) in. [mm]		¾ [19]	¾ [19]	1 [25]	1 [25]
Motor Sheave Size 3450 RPM 1 Ø Adjustment (std.) in. [mm] 1725 RPM 3		1.9-2.9 [48-74] 3.4-4.4 [86-112]	2.4-3.2 [61-81] 4.0-5.0 [102-127]	— 3.1-4.1 [79-104]	— 4.3-5.5 [109-140]
Coil Face Area, sq. feet [m²]		10.2 [.95]	10.2 [.95]	16.5 [1.53]	16.5 [1.53]
Coil Tube Diameter in. [mm]		¾ [10]	¾ [10]	¾ [10]	¾ [10]
Coil, Rows Deep—Fins Per Inch [mm]		3/15 [.51]	4/15 [.59]	3/15 [.51]	4/15 [.59]
Refrigerant Control—Thermal Expansion Valves (Quantity)		BIVE-3-GA-1616-8-¾/16-3-30"S (2)	CBIVE-5-GA-D236-8-¾/16-30"S	BIVE-6-GA-1113-11-¾/16-5-30"S	XVE-10-GA-D147-14-¾/16-10-30"S
Filter Size, in. [mm] (Number Required) Disposable*		16 x 25 x 1 (4) [406 x 635 x 25]	16 x 25 x 1 (4) [406 x 635 x 25]	20 x 25 x 1 (6) [508 x 635 x 25]	20 x 25 x 1 (6) [508 x 635 x 25]
CABINET:					
Finish		Powder Paint	Powder Paint	Powder Paint	Powder Paint
Sheet Metal		Galvanized	Galvanized	Galvanized	Galvanized
Gauge (nominal)					
Top		18	18	18	18
Sides		16	16	16	16
Bottom		18	18	16	16
Doors and Covers		20 min.	20 min.	20 min.	20 min.
UNIT WEIGHTS:					
Operating (lbs.) [kg]		330 [150]	347 [157]	495 [225]	545 [247]
Shipping (lbs.) [kg]		350 [159]	367 [166]	530 [240]	580 [263]
PACKAGED DIMENSIONS:					
(H x W x L) [mm]		31½" x 56" x 57¼" [800 x 1422 x 1454]	31½" x 56" x 57¼" [800 x 1422 x 1454]	39" x 63" x 76½" [991 x 1600 x 1943]	39" x 63" x 76½" [991 x 1600 x 1943]

*Unit will accept 2" [51 mm] filters.

NOTE: If a factory accessory heater kit is not used, a field supplied fan contactor is required and should have a 24 volt coil with contacts rated to handle the evaporator motor FLA at desired voltage. A factory supplied 30 Amp 3 Pole (Part #42-17810-83) or 30 Amp 2 Pole (Part #42-17759-03) contactor may be purchased from the Parts Department.

[] Designates Metric Conversions

DRIVE PACKAGE DATA

NOMINAL TONS [kW]	DRIVE PACKAGE	BELT	SHEAVE SELECTIONS*, IN. [mm]		MOTOR HP [W]/PHASE	APPROX. BLOWER RPM @ MOTOR SHEAVE TURNS OPEN								
			MOTOR/BORE	BLOWER		0	1	2	2.5	3	4	5	6	
7.5 [26]	K	4L530	3.4-4.4-5/8	[86-112-16]	9.75 [248]	1 [746]/30	790	760	730	715	700	665	630	—
	K	4L480	1.9-2.9	[48-74]	9.75 [248]	1 [746]/10	1025	965	900	—	830	760	695	—
	L	4L530	4.2-5.2-5/8	[107-132-16]	9.75 [248]	1.5 [1119]/30	925	895	860	845	825	790	750	—
	M	4L550	5.2-6.2-5/8	[132-157-16]	9.75 [248]	1.5 [1119]/30	1125	1090	1055	—	1020	985	945	—
	◇N	4L550	5.7-6.7-7/8	[145-170-22]	9.75 [248]	2 [1491]/30	1195	1165	1130	—	1100	1065	1030	—
10 [35]	J+	4L530	3.4-4.4	[86-112]	9.75 [248]	1.5 [1119]/30	790	760	725	—	690	660	630	—
	K	4L530	4.0-5.0-5/8	[102-127-16]	9.75 [248]	1.5 [1119]/30	885	855	825	—	795	760	730	—
	K	4L480	1.9-2.9	[48-74]	8.75 [222]	2 [1491]/10	1140	1070	995	—	920	845	770	—
	L	4L540	4.6-5.6-7/8	[117-142-22]	9.75 [248]	2 [1491]/30	995	960	930	—	895	860	825	—
	M	4L550	5.2-6.2-7/8	[132-157-22]	9.75 [248]	3 [2237]/30	1125	1090	1055	—	1020	985	945	—
	△N	4L530	4.7-5.7-7/8	[119-145-22]	7.75 [197]	3 [2237]/30	1225	1190	1150	—	1110	1070	1030	—
	□O	4L540	5.7-6.7-7/8	[145-170-22]	8.75 [222]	3 [2237]/30	1280	1250	1220	—	1185	1150	1115	—
15 [53]	K	BP-52	3.1-4.1-7/8	[79-104-22]	11.4 [290]	2 [1491]/30	645	620	590	—	565	535	510	480
	L	BP-52	3.7-4.7-7/8	[94-119-22]	11.4 [290]	3 [2237]/30	730	705	680	—	655	630	600	570
	M	BP-45	3.7-4.7-1 1/8	[94-119-29]	9.4 [239]	5 [3729]/30	870	840	810	—	780	750	715	680
	#N	BP-50	4.8-6.0-1 1/8	[122-152-29]	10.4 [264]	5 [3729]/30	985	960	935	—	910	885	860	835
20 [70]	K	BP-50	4.3-5.5-1 1/8	[109-140-29]	11.4 [290]	5 [3729]/30	850	825	800	—	775	745	715	685
	L	BP-48(2)	4.3-5.5-1 3/8	[109-140-35]	10.4 [264]	7.5 [5593]/30	955	925	895	—	865	835	805	780
	M	BP-47(2)	4.3-5.5-1 3/8	[109-140-35]	9.4 [239]	7.5 [5593]/30	1030	995	960	—	925	890	855	815

*Actual pitch diameter in inches. Minimum and maximum pitch diameter shown for adjustable motor sheave. ◇ Field Supplied (Motor Sheave: Browning IVP75, Blower Sheave: Browning AZ100, Motor: 2HP [1491 W], 4 Pole, 30). △ Field Supplied (Motor Sheave: Browning IVP65, Blower Sheave: Browning AZ80). □ Field Supplied (Motor Sheave: Browning IVP75, Blower Sheave: Browning AZ90). # Field Supplied (Motor Sheave: Browning IVP65, Blower Sheave: Browning BK110). + Field Supplied (Motor Sheave: Browning IVP50, Blower Sheave: Browning AZ100). Factory sheave settings are shown in bold print. The K, L, and M drives are available from the factory. The J, N, and O drives are not available from the factory and these sheaves and belts must be field supplied. A motor change is not required. The field supplied sheaves and belts are standard shelf items that are readily available from local equipment supply houses. The chart above gives the necessary specifications for these field supplied sheaves and belts.

[] Designates Metric Conversions

PERFORMANCE DATA @ ARI STANDARD CONDITIONS—COOLING

Dual Straight Cool Condensing Unit with Air Handler

MODEL NUMBERS		80°F [26.5°C] DB/67°F [19.5°C] WB INDOOR AIR 95°F [35°C] DB OUTDOOR AIR				SOUND RATING	INDOOR CFM [L/s]
OUTDOOR UNIT 2-RAKB-	INDOOR COIL AND/OR AIR HANDLER	NET TOTAL CAPACITY BTU/H [kW]	NET SENSIBLE BTU/H [kW]	NET LATENT BTU/H [kW]	EER		
036CA	(RHGG-090Z)	75,000 [22.0]	55,000 [16.1]	20,000 [5.9]	10.60	7.8	2,400 [1133]
036DA	(RHGG-090Z)	75,000 [22.0]	55,000 [16.1]	20,000 [5.9]	10.60	7.8	2,400 [1133]
042CA	(RHGG-090Z)	85,000 [24.9]	64,000 [18.8]	21,000 [6.2]	9.85	7.8	2,800 [1321]
	(RHGG-120Z)	88,000 [25.8]	66,000 [19.3]	22,000 [6.4]	10.00	7.8	2,800 [1321]
042CA	(RHGG-090H)	84,000 [24.6]	63,000 [18.5]	21,000 [6.2]	9.45	7.8	2,800 [1321]
	(RHGG-120H)	87,000 [25.5]	65,000 [19.0]	22,000 [6.4]	9.60	7.8	2,800 [1321]
048CA	(RHGG-090Z)	95,000 [27.8]	71,000 [20.8]	24,000 [7.0]	10.00	8.0	3,200 [1510]
	(RHGG-120Z)	98,000 [28.7]	74,000 [21.7]	24,000 [7.0]	10.20	8.0	3,200 [1510]
048DA	(RHGG-090Z)	95,000 [27.8]	71,000 [20.8]	24,000 [7.0]	10.00	8.0	3,200 [1510]
	(RHGG-120Z)	98,000 [28.7]	74,000 [21.7]	24,000 [7.0]	10.20	8.0	3,200 [1510]
060CA	(RHGG-090Z)	116,000 [34.0]	82,000 [24.0]	34,000 [10.0]	9.10	8.2	3,600 [1699]
	(RHGG-120Z)	120,000 [35.2]	90,000 [26.4]	30,000 [8.8]	9.00	8.2	4,000 [1888]
060DA	(RHGG-090Z)	116,000 [34.0]	82,000 [24.0]	34,000 [10.0]	9.10	8.2	3,600 [1699]
	(RHGG-120Z)	120,000 [35.2]	90,000 [26.4]	30,000 [8.8]	9.00	8.2	4,000 [1888]

PERFORMANCE DATA @ ARI STANDARD CONDITIONS—COOLING

MODEL NUMBERS		80°F [26.5°C] DB/67°F [19.5°C] WB INDOOR AIR 95°F [35°C] DB OUTDOOR AIR				SOUND RATING	INDOOR CFM [L/s]
OUTDOOR UNIT 2-RAND-	INDOOR COIL AND/OR AIR HANDLER	NET TOTAL CAPACITY BTU/H [kW]	NET SENSIBLE BTU/H [kW]	NET LATENT BTU/H [kW]	EER		
036C*	(RHGG-090Z)	71,000 [20.8]	54,000 [15.8]	17,000 [5.0]	12.20	7.6	2,400 [1133]
036D*	(RHGG-090Z)	71,000 [20.8]	54,000 [15.8]	17,000 [5.0]	12.20	7.6	2,400 [1133]
036J*	(RHGG-090H)	70,000 [20.5]	53,000 [15.5]	17,000 [5.0]	11.45	7.6	2,400 [1133]
042C*	(RHGG-090Z)	80,000 [23.4]	62,000 [18.2]	18,000 [5.3]	11.40	7.6	2,800 [1321]
	(RHGG-120Z)	83,000 [24.3]	67,000 [19.6]	16,000 [4.7]	11.80	7.6	2,800 [1321]
042D*	(RHGG-090Z)	80,000 [23.4]	62,000 [18.2]	18,000 [5.3]	11.40	7.6	2,800 [1321]
	(RHGG-120Z)	83,000 [24.3]	67,000 [19.6]	16,000 [4.7]	11.80	7.6	2,800 [1321]
042J*	(RHGG-090H)	79,000 [23.1]	61,000 [17.9]	18,000 [5.3]	10.90	7.6	2,800 [1321]
	(RHGG-120H)	82,000 [24.0]	66,000 [19.3]	16,000 [4.7]	11.25	7.6	2,800 [1321]
048C*	(RHGG-090Z)	92,000 [27.0]	70,000 [20.5]	22,000 [6.4]	11.30	7.6	3,200 [1510]
	(RHGG-120Z)	96,000 [28.1]	72,000 [21.1]	24,000 [7.0]	11.70	7.6	3,200 [1510]
048D*	(RHGG-090Z)	92,000 [27.0]	70,000 [20.5]	22,000 [6.4]	11.30	7.6	3,200 [1510]
	(RHGG-120Z)	96,000 [28.1]	72,000 [21.1]	24,000 [7.0]	11.70	7.6	3,200 [1510]
048J*	(RHGG-090H)	91,000 [26.7]	69,000 [20.2]	22,000 [6.4]	10.90	7.6	3,200 [1510]
	(RHGG-120H)	95,000 [27.8]	71,000 [20.8]	24,000 [7.0]	11.30	7.6	3,200 [1510]
060C*	(RHGG-090Z)	107,000 [31.4]	79,000 [23.1]	28,000 [8.2]	10.20	7.6	3,600 [1699]
	(RHGG-120Z)	112,000 [32.8]	86,000 [25.2]	26,000 [7.6]	10.10	7.6	4,000 [1888]
060D*	(RHGG-090Z)	107,000 [31.4]	79,000 [23.1]	28,000 [8.2]	10.20	7.6	3,600 [1699]
	(RHGG-120Z)	112,000 [32.8]	86,000 [25.2]	26,000 [7.6]	10.10	7.6	4,000 [1888]
060J*	(RHGG-090H)	106,000 [31.1]	78,000 [22.9]	28,000 [8.2]	10.10	7.6	3,400 [1604]
	(RHGG-120H)	111,000 [32.5]	85,000 [24.9]	26,000 [7.6]	9.80	7.6	4,000 [1888]

[] Designates Metric Conversions

INDOOR BLOWER PERFORMANCE (DRY COIL) RHGG-090 Z/Y

E.S.P.—INCHES OF WATER [kPa]

DRIVE PKG	STD CFM	E.S.P.—INCHES OF WATER [kPa]																																						
		.1 [0.02]	.2 [0.05]	.3 [0.07]	.4 [0.10]	.5 [0.12]	.6 [0.15]	.7 [0.17]	.8 [0.20]	.9 [0.22]	1.0 [0.25]	1.1 [0.27]	1.2 [0.30]	1.3 [0.32]	1.4 [0.35]	1.5 [0.37]	1.6 [0.40]	1.7 [0.42]	1.8 [0.45]	1.9 [0.47]	2.0 [0.50]																			
		RPM	W	RPM	W	RPM	W	RPM	W	RPM	W	RPM	W	RPM	W	RPM	W	RPM	W	RPM	W																			
	1800 [850 L/s]	—	—	—	—	—	—	—	—	—	—	—	—	—	—	—	—	—	—	—	—																			
	2000 [944 L/s]	—	—	—	—	—	—	—	—	—	—	—	—	—	—	—	—	—	—	—	—																			
	2200 [1038 L/s]	—	—	—	—	—	—	—	—	—	—	—	—	—	—	—	—	—	—	—	—																			
K	2400 [1133 L/s]	—	—	—	—	—	—	—	—	—	—	—	—	—	—	—	—	—	—	—	—																			
L	2600 [1227 L/s]	—	—	—	—	—	—	—	—	—	—	—	—	—	—	—	—	—	—	—	—																			
M	2800 [1321 L/s]	—	—	—	—	—	—	—	—	—	—	—	—	—	—	—	—	—	—	—	—																			
N	3000 [1416 L/s]	630	660	730	695	775	730	840	770	920	800	995	830	1060	860	1145	890	1220	935	1230	965	1285	995	1345	1020	1405	1050	1505	1080	1560	1110	1640	1115	1650	1140	1740	1170	1815	1195	1885
	3200 [1510 L/s]	660	810	695	860	725	920	765	1000	795	1070	825	1140	855	1225	890	1315	920	1370	960	1385	985	1445	1015	1530	1040	1620	1070	1685	1085	1695	1115	1780	1135	1875	—	—	—	—	
	3400 [1605 L/s]	690	940	725	1000	760	1090	790	1155	820	1225	850	1325	885	1410	915	1460	950	1485	980	1570	1010	1660	1030	1680	1045	1745	1075	1830	—	—	—	—	—	—	—	—	—	—	
	3600 [1699 L/s]	720	1120	750	1185	790	1250	820	1315	850	1430	885	1520	915	1590	945	1605	975	1695	—	—	—	—	—	—	—	—	—	—	—	—	—	—	—	—	—	—	—	—	—

K = IVP50, AZ100, 1 HP [766 W] L = IVP60, AZ100, 1 1/2 HP [1119 W] M = IVP68, AZ100, 1 1/2 [1119 W] HP N = IVP75, AZ100, 2 HP [1491 W] [Field Supplied]

NOTE: Bold lines separate K, L, M and N drives respectively.

RHGG-090 HK

E.S.P.—INCHES OF WATER [kPa]

DRIVE PKG	STD CFM	E.S.P.—INCHES OF WATER [kPa]																			
		.1 [0.02]	.2 [0.05]	.3 [0.07]	.4 [0.10]	.5 [0.12]	.6 [0.15]	.7 [0.17]	.8 [0.20]	.9 [0.22]	1.0 [0.25]	1.1 [0.27]	1.2 [0.30]	1.3 [0.32]	1.4 [0.35]	1.5 [0.37]	1.6 [0.40]	1.7 [0.42]	1.8 [0.45]	1.9 [0.47]	2.0 [0.50]
		RPM	W	RPM	W	RPM	W	RPM	W	RPM	W	RPM	W	RPM	W	RPM	W	RPM	W	RPM	W
	2200 [1038 L/s]	—	—	—	—	—	—	—	—	—	—	—	—	—	—	—	—	—	—	—	—
	2400 [1133 L/s]	—	—	—	—	—	—	—	—	—	—	—	—	—	—	—	—	—	—	—	—
	2600 [1227 L/s]	—	—	—	—	—	—	—	—	—	—	—	—	—	—	—	—	—	—	—	—
K	2800 [1321 L/s]	—	—	—	—	—	—	—	—	—	—	—	—	—	—	—	—	—	—	—	—
	3000 [1416 L/s]	—	—	—	—	—	—	—	—	—	—	—	—	—	—	—	—	—	—	—	—
	3200 [1510 L/s]	—	—	—	—	—	—	—	—	—	—	—	—	—	—	—	—	—	—	—	—
	3400 [1605 L/s]	—	—	—	—	—	—	—	—	—	—	—	—	—	—	—	—	—	—	—	—
	3600 [1699 L/s]	710	1180	750	1290	—	—	—	—	—	—	—	—	—	—	—	—	—	—	—	—

K = IVP34, AZ100, 1 HP [746 W] 10
 NOTES: T.O. = Turns Open
 1. Standard air @ .075 lbs/ft³
 2. Operation below heavy lines require optional drives.
 3. Motor efficiency = .70
 4. BHP = WATTS x MOTOR EFFICIENCY
 746
 5. BHP = Brake Horsepower
 RPM = Blower Speed

[] Designates Metric Conversions

INDOOR BLOWER PERFORMANCE RHGG-15 TON [53 kW] & 20 TON [70 kW] (DRY COIL)

RHGG-180 Z/Y

DRIVE PKG	STD CFM	E.S.P.—INCHES OF WATER [kPa]																								
		.1 [0.02]	.2 [0.05]	.3 [0.07]	.4 [0.10]	.5 [0.12]	.6 [0.15]	.7 [0.17]	.8 [0.20]	.9 [0.22]	1.0 [0.25]	1.1 [0.27]	1.2 [0.30]	1.3 [0.32]	1.4 [0.35]	1.5 [0.37]	1.6 [0.40]	1.7 [0.42]	1.8 [0.45]	1.9 [0.47]	2.0 [0.50]					
		RPM	W	RPM	W	RPM	W	RPM	W	RPM	W	RPM	W	RPM	W	RPM	W	RPM	W	RPM	W	RPM	W			
K	4000 [1888 L/s]	—	—	—	480	950	510	1020	540	1090	565	1165	595	1250	620	1320	645	1400	665	1575	690	1740	710	1860		
	4400 [2077 L/s]	—	—	—	505	1090	530	1175	560	1250	585	1325	610	1385	635	1485	655	1650	680	1770	700	1945	725	2035		
	4800 [2265 L/s]	—	—	—	495	1185	520	1275	550	1355	575	1440	595	1520	620	1600	645	1700	665	1880	690	2015	710	2170	730	2290
	5200 [2454 L/s]	—	—	—	490	1300	515	1385	545	1485	565	1550	590	1660	615	1760	635	1850	660	2050	685	2170	705	2320	725	2460
L	5600 [2643 L/s]	490	1420	515	1505	540	1620	560	1700	590	1820	610	1905	635	2080	660	2240	680	2365	700	2510	720	2665	740	2740	
	6000 [2832 L/s]	510	1640	530	1750	560	1860	590	1950	610	2165	630	2270	660	2450	675	2570	695	2725	720	2905	740	2975	765	3100	
M-N	6400 [3020 L/s]	530	1900	555	1980	590	2255	610	2370	630	2470	655	2660	675	2800	695	2965	720	3180	735	3255	760	3360	775	3485	
	6800 [3209 L/s]	570	2370	590	2455	610	2575	625	2670	655	2870	675	3030	700	3055	720	3175	740	3350	760	3485	780	3620	800	3750	
	7200 [3398 L/s]	590	2885	610	2800	630	2945	650	3100	680	3195	700	3310	720	3450	745	3610	720	3745	780	3910	800	4040	820	4230	

K = IVP44, BK120, 2 HP [1491 W]
 L = IVP50, BK120, 3 HP [2237 W]
 M = IVP50, BK100, 5 HP [3729 W]
 N = IVP65, BK110, 5 HP [3729 W] [Field Supplied]
 NOTE: Bold lines separate K, L, M and N drives respectively.

RHGG-240 Z/Y

DRIVE PKG	STD CFM	E.S.P.—INCHES OF WATER [kPa]																					
		.1 [0.02]	.2 [0.05]	.3 [0.07]	.4 [0.10]	.5 [0.12]	.6 [0.15]	.7 [0.17]	.8 [0.20]	.9 [0.22]	1.0 [0.25]	1.1 [0.27]	1.2 [0.30]	1.3 [0.32]	1.4 [0.35]	1.5 [0.37]	1.6 [0.40]	1.7 [0.42]	1.8 [0.45]	1.9 [0.47]	2.0 [0.50]		
		RPM	W	RPM	W	RPM	W	RPM	W	RPM	W	RPM	W	RPM	W	RPM	W	RPM	W	RPM	W	RPM	W
K	6000 [2832 L/s]	—	—	—	—	—	—	—	—	—	—	—	—	—	—	—	—	—	—	—	—	—	—
	6500 [3068 L/s]	—	—	—	—	—	—	—	—	—	—	—	—	—	—	—	—	—	—	—	—	—	—
	7000 [3304 L/s]	—	—	—	—	—	—	—	—	—	—	—	—	—	—	—	—	—	—	—	—	—	—
	7500 [3540 L/s]	—	—	—	—	—	—	—	—	—	—	—	—	—	—	—	—	—	—	—	—	—	—
L-M	8000 [3776 L/s]	—	—	—	—	—	—	—	—	—	—	—	—	—	—	—	—	—	—	—	—	—	—
	8500 [4012 L/s]	—	—	—	—	—	—	—	—	—	—	—	—	—	—	—	—	—	—	—	—	—	—
	9000 [4248 L/s]	685	4070	700	4240	720	4440	735	4615	760	4790	780	4995	815	5165	830	5300	850	5435	865	5570	880	5720
	9500 [4484 L/s]	700	4730	720	4940	785	5325	800	5500	820	5670	835	5790	850	5920	865	6060	880	6210	895	6370	905	6530
	10000 [4719 L/s]	805	6080	815	6145	830	6470	840	6615	860	6720	870	6890	885	7040	900	7220	915	7430	925	7600	—	—

K = IVP60, BK120, 5 HP [3729 W]
 L = 2VP60, 2BK110, 7 1/2 HP [5593 W]
 M = 2VP60, 2BK100, 7 1/2 HP [5593 W]
 NOTES: 1. Bold lines separate K, L and M drives respectively.
 2. Standard air @ .075 lbs/ft³ [m³]
 3. Operation below heavy lines require optional drives.
 4. Motor efficiency = .85
 5. BHP = WATTS x MOTOR EFFICIENCY
 746
 6. BHP = Brake Horsepower
 RPM = Blower Speed

[] Designates Metric Conversions

COMPONENT AIR RESISTANCE

RHGG 7.5 TON [26 kW] & 10 TON [35 kW]

CFM [L/s]	1800 [850]	2200 [1038]	2600 [1227]	3000 [1416]	3400 [1605]	3800 [1793]	4200 [1982]	4600 [2171]	5000 [2360]
Electric Heater 20KW, 30KW	.060 [.015]	.100 [.025]	.140 [.034]	.160 [.040]	.230 [.057]	.320 [.080]	.410 [.102]	.500 [.124]	.600 [.150]
Electric Heater 40KW	.070 [.017]	.110 [.027]	.140 [.034]	.240 [.060]	.350 [.090]	.480 [.119]	.600 [.150]	.730 [.181]	.860 [.214]
Mixing Box (R/A Damper Open)	.006 [.001]	.008 [.002]	.012 [.003]	.024 [.006]	.038 [.009]	.053 [.013]	.068 [.017]	.080 [.020]	.095 [.024]
Discharge Grille (Set Max. Open)	.008 [.002]	.011 [.003]	.015 [.004]	.020 [.005]	.025 [.006]	.031 [.008]	.039 [.010]	.046 [.012]	.055 [.014]
Inlet Grille	.008 [.002]	.010 [.002]	.014 [.003]	.020 [.005]	.026 [.006]	.032 [.008]	.039 [.010]	.049 [.012]	.058 [.014]
Discharge Plenum	.02 [.005]	.04 [.010]	.05 [.012]	.065 [.016]	.085 [.021]	.100 [.025]	.120 [.030]	.150 [.037]	.180 [.045]

RHGG 15 TON [53 kW]

CFM [L/s]	4000 [1888]	4400 [2077]	4800 [2265]	5200 [2454]	5600 [2643]	6000 [2832]	6400 [3020]	6800 [3209]	7200 [3398]
Electric Heater 20KW, 30KW	.175 [.040]	.187 [.050]	.200 [.049]	.215 [.053]	.230 [.057]	.250 [.062]	.275 [.068]	.305 [.076]	.350 [.087]
Electric Heater 40KW, 60KW	.290 [.070]	.320 [.080]	.350 [.087]	.380 [.095]	.410 [.102]	.450 [.112]	.495 [.123]	.550 [.137]	.600 [.149]
Mixing Box (R/A Damper Open)	.030 [.007]	.037 [.009]	.044 [.011]	.052 [.013]	.061 [.015]	.071 [.018]	.091 [.023]	.102 [.025]	.110 [.027]
Discharge Grille (Set Max. Open)	.010 [.003]	.012 [.003]	.014 [.004]	.017 [.004]	.019 [.005]	.022 [.006]	.025 [.006]	.029 [.007]	.032 [.008]
Inlet Grille	.010 [.002]	.014 [.003]	.020 [.005]	.027 [.007]	.035 [.009]	.044 [.011]	.054 [.013]	.065 [.016]	.077 [.019]
Discharge Plenum	.02 [.005]	.04 [.010]	.05 [.012]	.065 [.016]	.085 [.021]	.100 [.025]	.120 [.030]	.150 [.037]	.180 [.045]

RHGG 20 TON [70 kW]

CFM [L/s]	6400 [3020]	6800 [3209]	7200 [3398]	7600 [3586]	8000 [3776]	8400 [3964]	8800 [4153]	9200 [4342]	9600 [4531]
Electric Heater 20KW, 30KW	.220 [.055]	.230 [.057]	.240 [.060]	.260 [.065]	.280 [.070]	.300 [.075]	.320 [.080]	.340 [.085]	.370 [.092]
Electric Heater 40KW, 60KW	.360 [.090]	.390 [.097]	.420 [.104]	.450 [.112]	.490 [.122]	.530 [.132]	.570 [.142]	.610 [.152]	.650 [.162]
Mixing Box (R/A Damper Open)	.095 [.023]	.102 [.025]	.110 [.027]	.115 [.030]	.121 [.030]	.126 [.031]	.128 [.032]	.135 [.034]	.142 [.035]
Discharge Grille (Set Max. Open)	.025 [.006]	.029 [.007]	.032 [.008]	.036 [.009]	.040 [.010]	.044 [.011]	.048 [.012]	.053 [.013]	.057 [.014]
Inlet Grille	.054 [.013]	.065 [.016]	.077 [.019]	.090 [.022]	.104 [.026]	.120 [.030]	.150 [.037]	.190 [.047]	.240 [.060]
Discharge Plenum	.120 [.030]	.150 [.037]	.180 [.045]	.210 [.052]	.250 [.062]	.290 [.072]	.340 [.085]	.400 [.010]	.470 [.117]

NOTE: Add component resistance to duct resistance to determine total E.S.P.

BLOWER PERFORMANCE CURVES—7.5 TON [26 kW] (WET COIL)

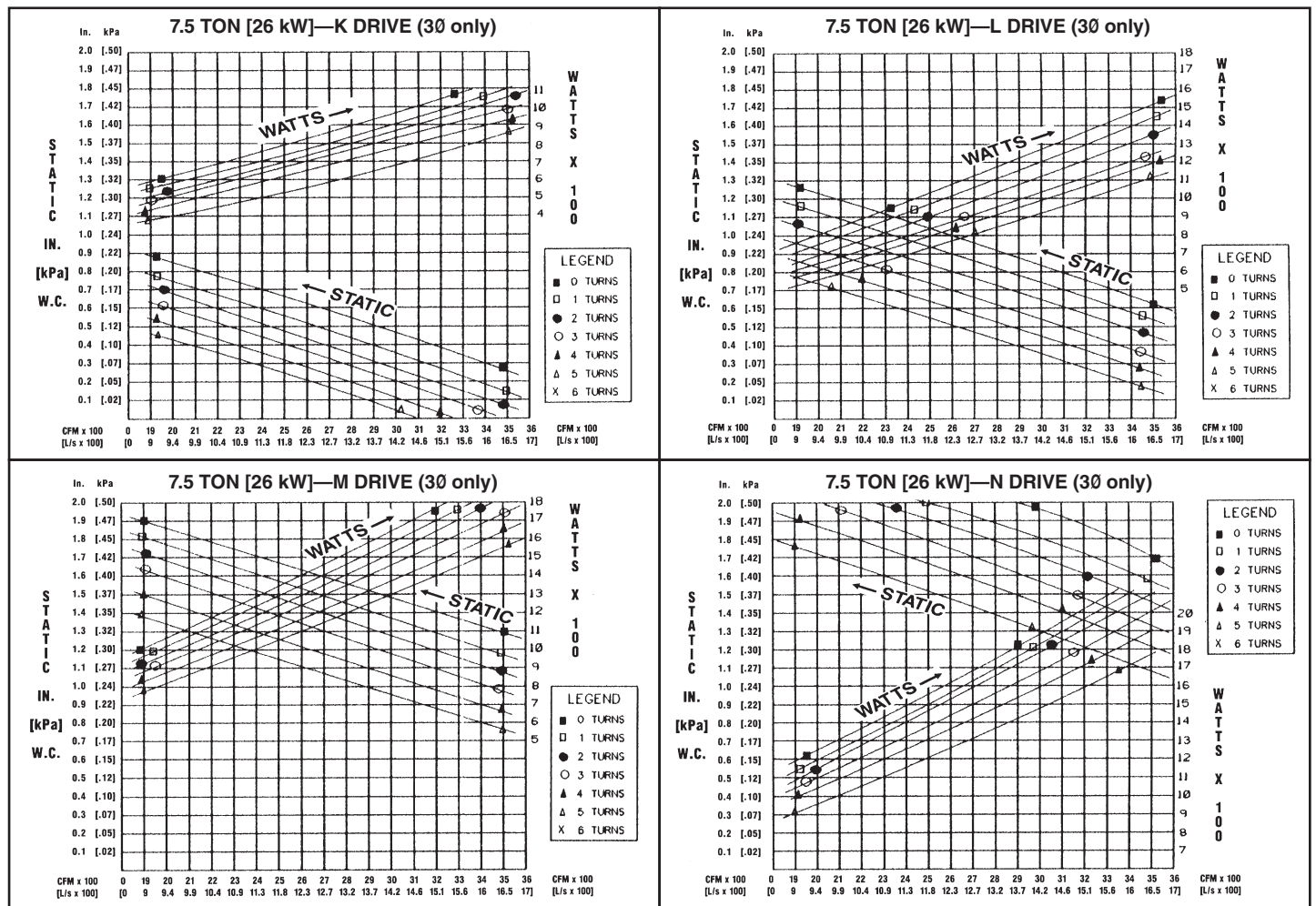

BLOWER PERFORMANCE CURVES—10 TON [35 kW] (WET COIL)

10 TON [35 kW] (RHGG-120 ONLY)
J DRIVE (3Ø only)

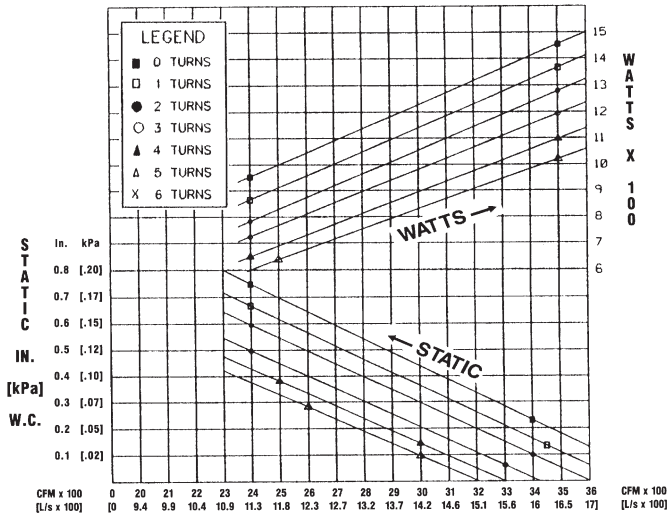

10 TON [35 kW]
K DRIVE (3Ø only)

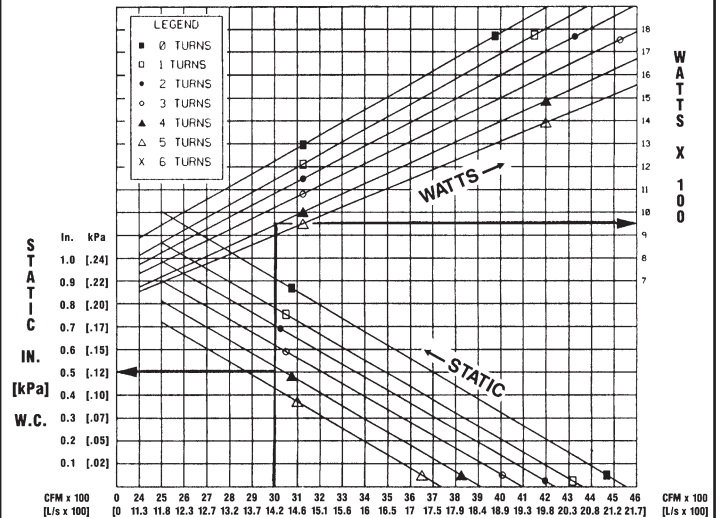

10 TON [35 kW]
L DRIVE (3Ø only)

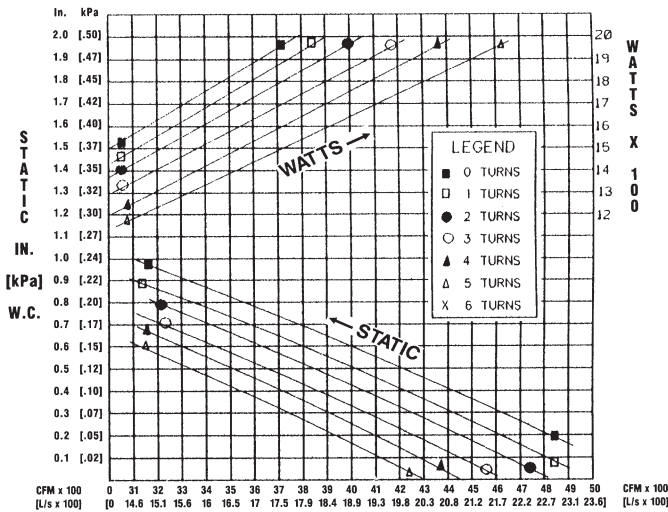

10 TON [35 kW]
M DRIVE (3Ø only)

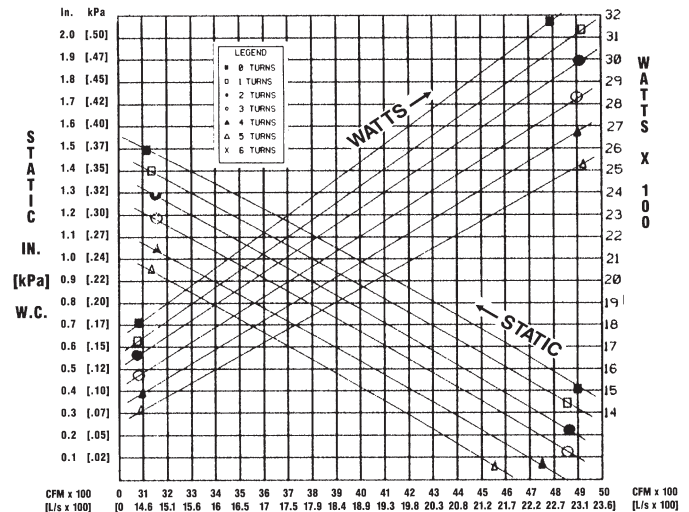

10 TON [35 kW]
N DRIVE (3Ø only)

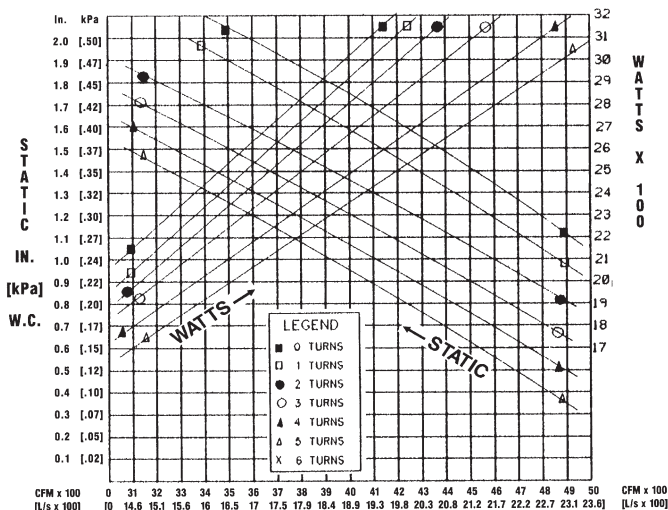

10 TON [35 kW]
O DRIVE (3Ø only)

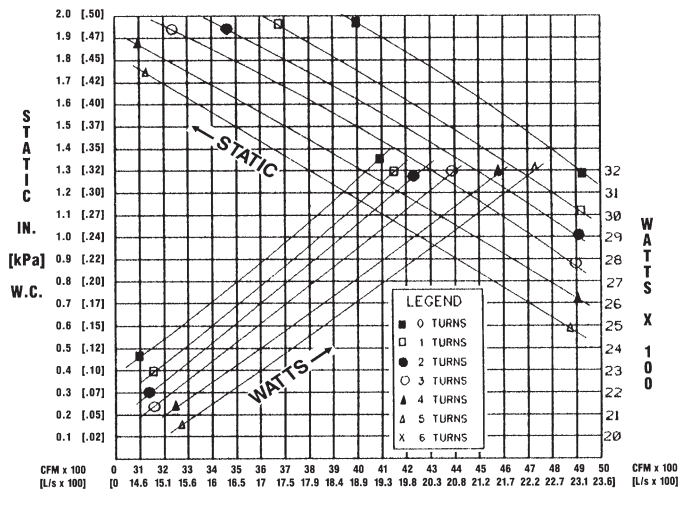

BLOWER PERFORMANCE CURVES—15 TON [53 kW] (WET COIL)

15 TON [53 kW]
M DRIVE

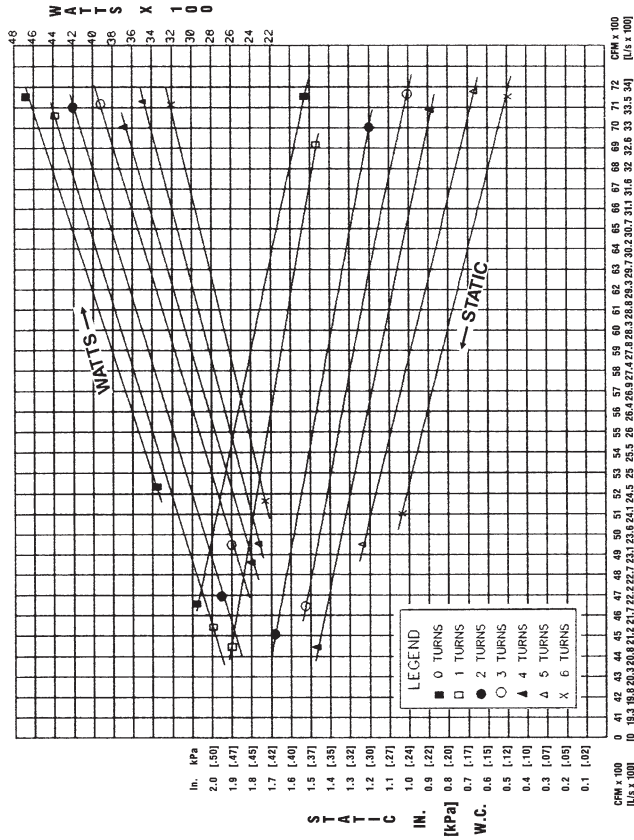

15 TON [53 kW]
N DRIVE

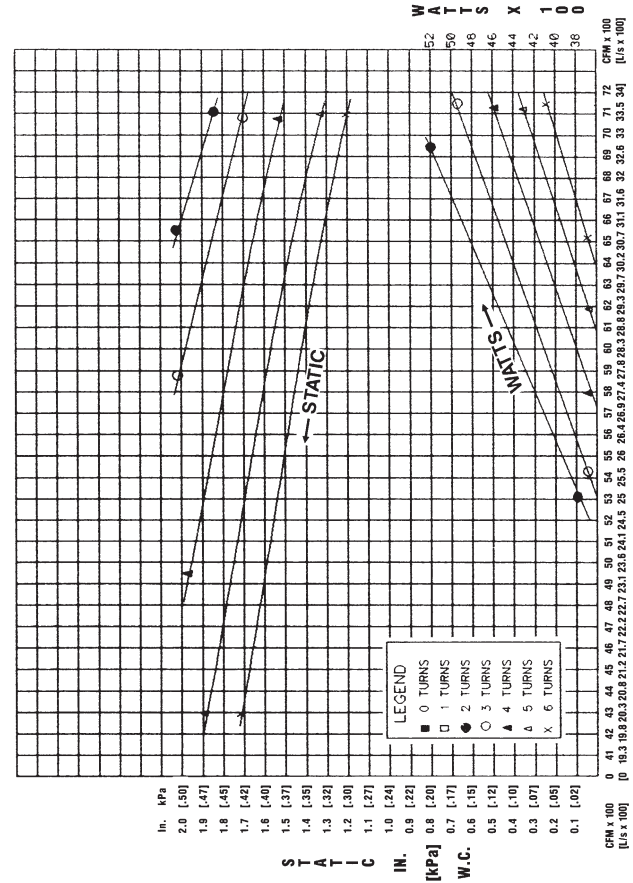

15 TON [53 kW]
K DRIVE

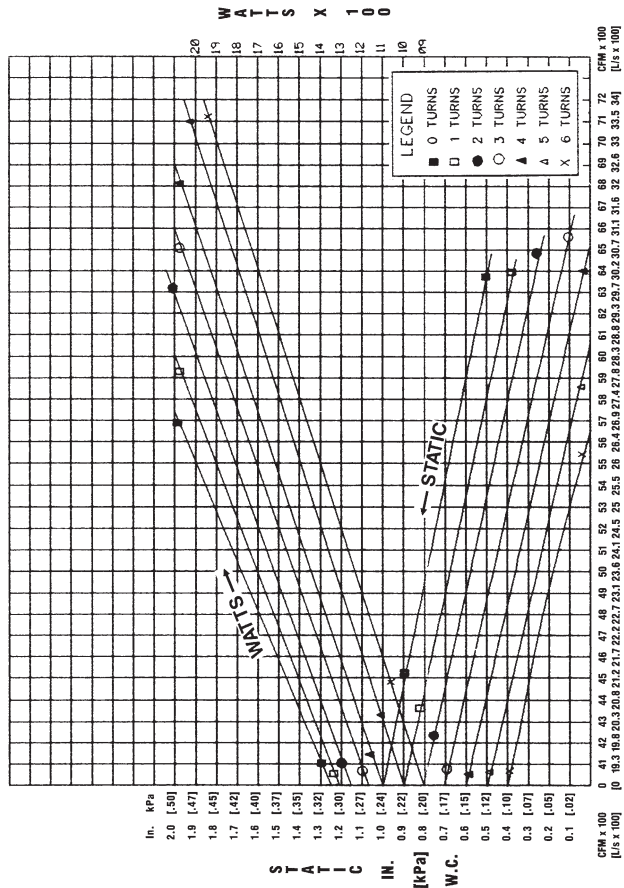

15 TON [53 kW]
L DRIVE

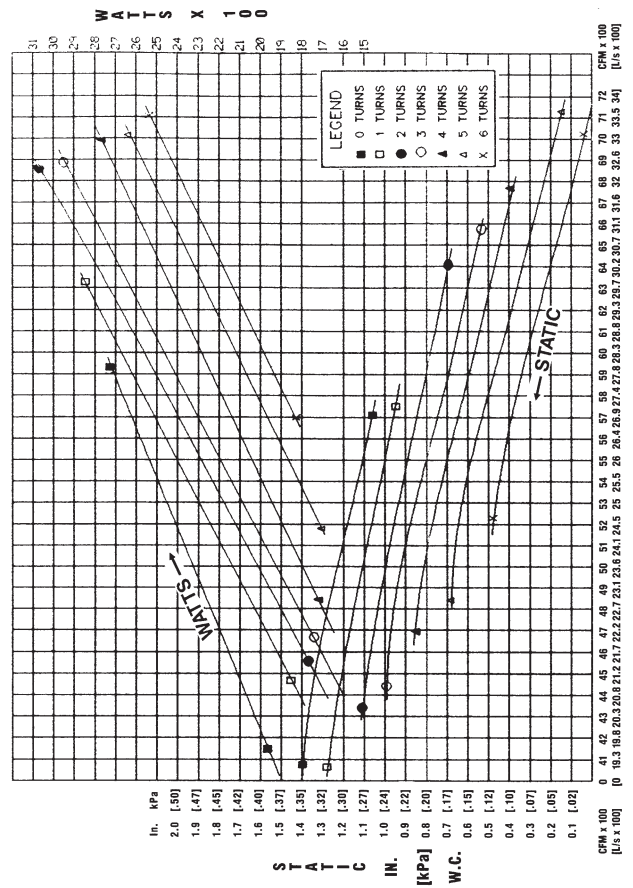

BLOWER PERFORMANCE CURVES—20 TON [70 kW] (WET COIL)

20 TON [70 kW]
K DRIVE

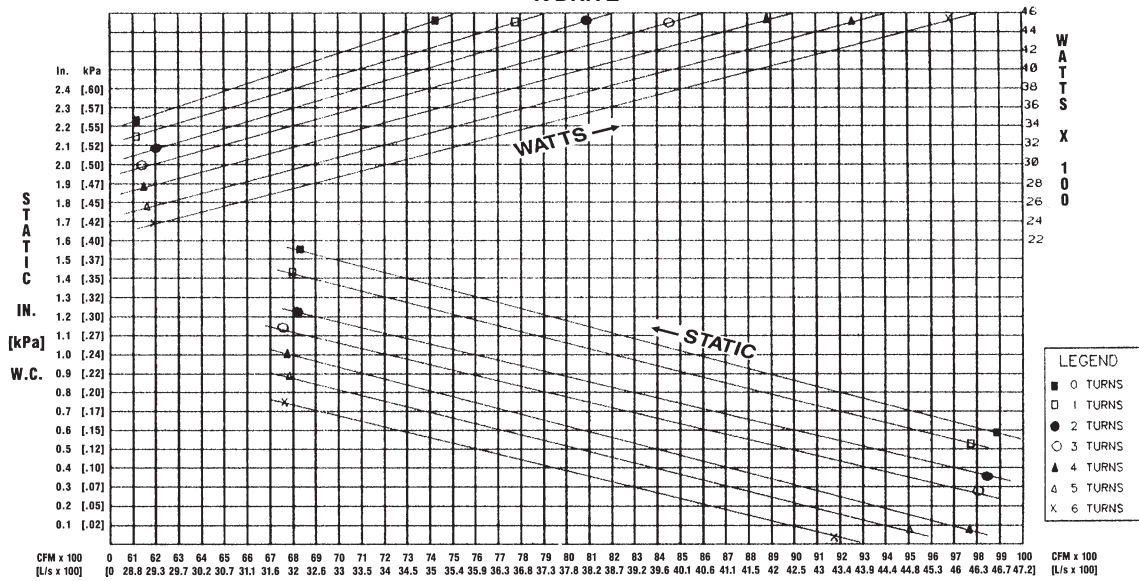

20 TON [70 kW]
L DRIVE

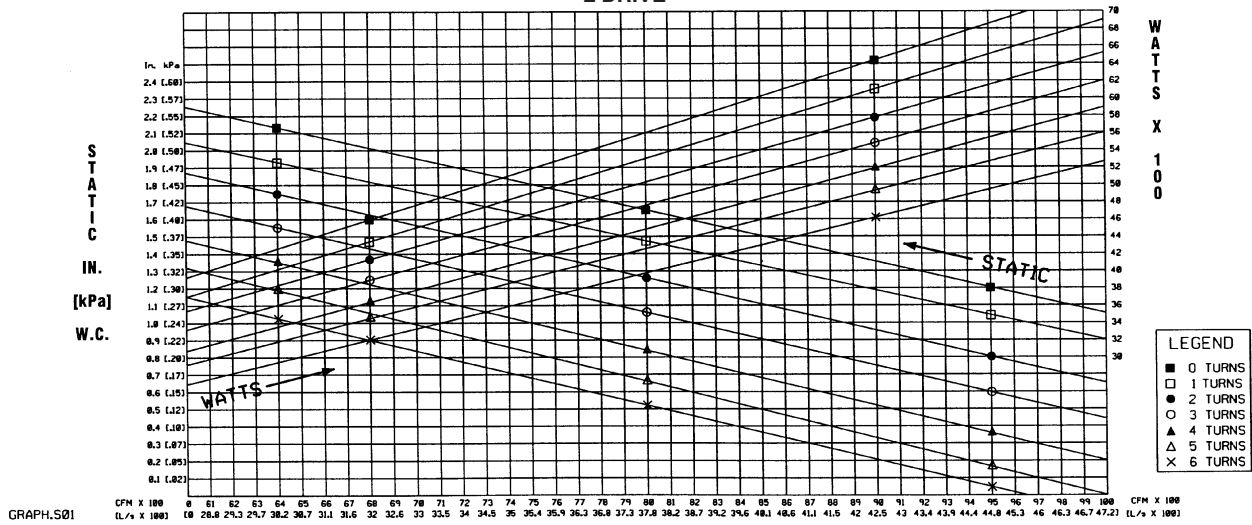

20 TON [70 kW]
M DRIVE

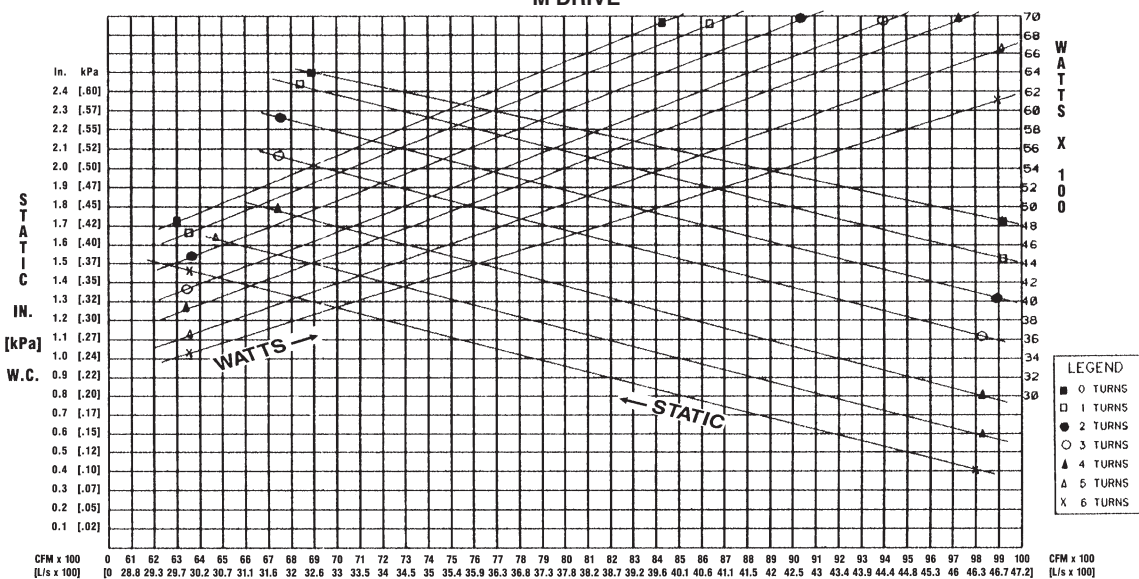

EVAPORATOR PERFORMANCE DATA

EVAPORATOR/AIR HANDLER RHGG-090 @ 3000 CFM [1416 L/s] 105°F (40.6°C) LIQUID TEMPERATURE AT TXV									
EVAP TEMP °F [°C]	EVAP INLET AIR WB °F [°C]	TOTAL CAPAC MBH [kW]	EVAP LVG AIR WB °F [°C]	EVAPORATOR ENTERING AIR DB—°F [°C]					
				70 [21]	75 [24]	80 [27]	85 [29]	90 [32]	95 [35]
				SENSIBLE CAPACITY					
				MBH [kW]	MBH [kW]	MBH [kW]	MBH [kW]	MBH [kW]	MBH [kW]
35 [1.5]	59 [15]	108.7 [31.8]	44.9 [7.2]	78.9 [23.1]	93.9 [27.5]	108.3 [31.7]	108.3 [31.7]	108.7 [31.8]	107.7 [31.8]
	63 [17]	127.6 [37.4]	47.6 [8.7]	73.2 [21.4]	88.0 [25.8]	102.9 [30.1]	117.8 [34.5]	127.6 [37.4]	127.6 [37.4]
	67 [19]	146.3 [42.9]	50.7 [10.4]	63.4 [18.6]	81.5 [23.9]	96.2 [28.2]	111.0 [32.5]	125.9 [36.9]	140.8 [41.3]
	71 [21.5]	168.6 [49.4]	53.3 [11.8]	—	70.4 [20.6]	89.0 [26.1]	103.7 [30.4]	118.3 [34.7]	133.0 [39.0]
	75 [24]	186.8 [54.7]	57.3 [14.1]	—	58.0 [17.0]	76.6 [22.4]	94.7 [27.7]	110.1 [32.3]	124.6 [36.5]
40 [4.5]	59 [15]	90.0 [26.4]	47.5 [8.6]	69.6 [20.4]	84.2 [24.7]	90.0 [26.4]	90.0 [26.4]	90.0 [26.4]	90.0 [26.4]
	63 [17]	109.8 [32.2]	50.0 [10.0]	64.4 [18.9]	79.5 [23.3]	94.5 [27.7]	109.0 [31.9]	109.8 [32.2]	109.8 [32.2]
	67 [19]	129.3 [37.9]	52.9 [11.6]	56.3 [16.5]	73.7 [21.6]	88.6 [26.0]	103.5 [30.3]	118.5 [34.7]	129.3 [37.9]
	71 [21.5]	143.6 [42.1]	55.2 [12.9]	—	64.3 [18.8]	82.1 [24.1]	96.8 [28.4]	111.8 [32.8]	126.7 [37.1]
	75 [24]	172.7 [50.6]	58.9 [14.9]	—	52.8 [15.5]	71.4 [20.9]	89.7 [26.3]	104.3 [30.6]	119.0 [34.9]
45 [7]	59 [15]	68.8 [20.2]	50.4 [10.2]	59.6 [17.5]	68.8 [20.2]	68.8 [20.2]	68.8 [20.2]	68.8 [20.2]	68.8 [20.2]
	63 [17]	89.3 [26.2]	52.7 [11.5]	54.9 [16.1]	70.1 [20.5]	84.8 [24.8]	89.3 [26.2]	89.3 [26.2]	89.3 [26.2]
	67 [19]	109.4 [32.1]	55.3 [12.9]	48.3 [14.2]	64.8 [19.0]	79.9 [23.4]	95.0 [27.8]	109.4 [32.1]	109.4 [32.1]
	71 [21.5]	124.1 [36.4]	57.6 [14.2]	—	57.1 [16.7]	74.1 [21.7]	89.1 [26.1]	104.1 [30.5]	119.1 [34.9]
	75 [24]	155.0 [45.4]	60.9 [16.1]	—	46.5 [13.6]	60.9 [17.8]	82.5 [24.2]	97.3 [28.5]	112.3 [32.9]
50 [10]	59 [15]	49.1 [14.4]	53.0 [11.7]	49.1 [14.4]	49.1 [14.4]	49.1 [14.4]	49.1 [14.4]	49.1 [14.4]	49.1 [14.4]
	63 [17]	65.8 [19.3]	55.6 [13.1]	44.6 [13.1]	59.7 [17.5]	65.8 [19.3]	65.8 [19.3]	65.8 [19.3]	65.8 [19.3]
	67 [19]	86.1 [25.2]	58.1 [14.5]	39.8 [11.7]	55.3 [16.2]	70.6 [20.7]	85.3 [25.0]	86.1 [25.2]	86.1 [25.2]
	71 [21.5]	100.7 [29.5]	60.2 [15.7]	—	49.2 [14.4]	65.2 [19.1]	80.4 [23.6]	95.6 [28.0]	100.7 [29.5]
	75 [24]	133.5 [39.1]	63.1 [17.3]	—	39.2 [11.5]	58.0 [17.0]	74.5 [21.8]	89.5 [26.2]	104.6 [30.6]

EVAPORATOR/AIR HANDLER RHGG-120 @ 3800 CFM [1793 L/s] 105°F (40.6°C) LIQUID TEMPERATURE AT TXV									
EVAP TEMP °F [°C]	EVAP INLET AIR WB °F [°C]	TOTAL CAPAC MBH [kW]	EVAP LVG AIR WB °F [°C]	EVAPORATOR ENTERING AIR DB—°F [°C]					
				70 [21]	75 [24]	80 [27]	85 [29]	90 [32]	95 [35]
				SENSIBLE CAPACITY					
				MBH [kW]	MBH [kW]	MBH [kW]	MBH [kW]	MBH [kW]	MBH [kW]
35 [1.5]	59 [15]	128.3 [37.6]	46.1 [7.8]	90.8 [26.6]	108.6 [31.8]	125.6 [36.8]	128.3 [37.6]	128.3 [37.6]	128.3 [37.6]
	63 [17]	147.4 [43.2]	49.2 [9.6]	82.0 [24.0]	99.4 [29.1]	117.3 [34.4]	134.8 [39.5]	147.4 [43.2]	147.4 [43.2]
	67 [19]	166.9 [48.9]	52.6 [11.4]	69.4 [20.3]	89.8 [26.3]	107.1 [31.4]	124.6 [36.5]	142.1 [41.6]	159.7 [46.8]
	71 [21.5]	185.0 [54.2]	56.3 [13.5]	—	75.8 [22.2]	96.3 [28.2]	113.2 [33.2]	130.7 [38.3]	147.9 [43.3]
	75 [24]	201.6 [59.1]	60.2 [15.7]	—	59.3 [17.4]	81.2 [23.8]	101.6 [29.8]	118.2 [34.6]	135.2 [39.6]
40 [4.5]	59 [15]	122.9 [36.0]	46.7 [8.2]	81.8 [24.0]	99.6 [29.2]	122.9 [36.0]	122.9 [36.0]	122.9 [36.0]	122.9 [36.0]
	63 [17]	130.5 [38.2]	48.2 [9.0]	74.2 [21.7]	92.1 [27.0]	109.9 [32.2]	127.2 [37.3]	130.5 [38.2]	130.5 [38.2]
	67 [19]	152.3 [44.6]	54.0 [12.2]	63.3 [18.6]	83.2 [24.4]	101.0 [29.6]	118.7 [34.8]	136.6 [40.0]	152.3 [44.6]
	71 [21.5]	173.1 [50.7]	57.5 [14.2]	—	71.1 [20.8]	91.2 [26.7]	108.6 [31.8]	126.3 [37.0]	143.9 [42.2]
	75 [24]	191.9 [56.2]	61.1 [16.2]	—	55.9 [16.4]	77.7 [22.8]	97.9 [28.7]	118.2 [34.6]	132.2 [38.7]
45 [7]	59 [15]	108.8 [31.9]	48.2 [9.0]	71.2 [20.9]	93.2 [27.3]	108.8 [31.9]	108.8 [31.9]	108.8 [31.9]	108.8 [31.9]
	63 [17]	119.0 [34.9]	52.1 [11.2]	64.6 [18.9]	83.0 [24.3]	100.8 [29.5]	119.0 [34.9]	119.0 [34.9]	119.0 [34.9]
	67 [19]	133.4 [39.1]	55.8 [13.2]	55.7 [16.3]	75.2 [22.0]	93.2 [27.3]	111.2 [32.6]	129.0 [37.8]	133.4 [39.1]
	71 [21.5]	156.4 [45.8]	58.9 [14.9]	—	64.9 [19.0]	84.5 [24.8]	102.2 [29.9]	120.2 [35.2]	138.2 [40.5]
	75 [24]	177.6 [52.0]	62.3 [16.8]	—	51.0 [14.9]	72.8 [21.3]	92.5 [27.1]	110.1 [32.3]	127.7 [37.4]
50 [10]	59 [15]	93.8 [27.5]	49.8 [9.9]	61.8 [18.1]	77.9 [22.8]	93.8 [27.5]	93.8 [27.5]	93.8 [27.5]	93.8 [27.5]
	63 [17]	103.1 [30.2]	53.7 [12.1]	53.8 [15.8]	72.2 [21.1]	103.1 [30.2]	103.1 [30.2]	103.1 [30.2]	103.1 [30.2]
	67 [19]	110.0 [32.2]	57.9 [14.4]	55.6 [16.3]	65.6 [19.2]	84.0 [24.6]	101.9 [29.9]	110.0 [32.2]	110.0 [32.2]
	71 [21.5]	135.0 [39.6]	60.8 [16.0]	—	57.2 [16.8]	76.3 [22.3]	94.4 [27.7]	112.5 [33.0]	130.3 [38.2]
	75 [24]	158.9 [46.6]	63.8 [17.7]	—	44.5 [13.0]	66.5 [19.5]	85.6 [25.1]	103.6 [30.4]	121.6 [35.6]

NOTES: 1. Total and sensible capacity is gross with no deduction for indoor blower motor heat. 2. Interpolation is permissible. Do not extrapolate.
3. Capacities are based on 105°F (40.6°C) liquid temperature at the TXV or about 95°F (35°C) dry bulb outdoor ambient.

AIRFLOW CORRECTION FACTORS

RHGG-090 @ 3000 CFM [1416 L/s]							
ACTUAL—CFM [L/s]	2400 [1133]	2600 [1227]	2800 [1321]	3000 [1416]	3200 [1510]	3400 [1605]	3600 [1699]
TOTAL MBH	0.85	0.90	0.95	1.00	1.04	1.09	1.13
SENSIBLE MBH	0.83	0.88	0.94	1.00	1.06	1.11	1.16

NOTES: 1. Multiply correction factor times gross performance data.
2. Resulting sensible capacity cannot exceed total capacity.

RHGG-120 @ 3800 CFM [1793 L/s]													
ACTUAL—CFM [L/s]	2400 [1133]	2600 [1227]	2800 [1321]	3000 [1416]	3200 [1510]	3400 [1605]	3600 [1699]	3800 [1793]	4000 [1888]	4200 [1982]	4400 [2077]	4600 [2171]	4800 [2265]
TOTAL MBH	0.76	0.79	0.82	0.85	0.89	0.93	0.97	1.00	1.03	1.06	1.10	1.12	1.15
SENSIBLE MBH	0.68	0.73	0.78	0.82	0.87	0.91	0.96	1.00	1.04	1.08	1.13	1.17	1.21

NOTES: 1. Multiply correction factor times gross performance data.
2. Resulting sensible capacity cannot exceed total capacity.

EVAPORATOR PERFORMANCE DATA

EVAPORATOR/AIR HANDLER RHGG-180 @ 6000 CFM [2832 L/s] 105°F (40.6°C) LIQUID TEMPERATURE AT TXV									
EVAP TEMP °F [°C]	EVAP INLET AIR WB °F [°C]	TOTAL CAPAC MBH [kW]	EVAP LVG AIR WB °F [°C]	EVAPORATOR ENTERING AIR DB—°F [°C]					
				70 [21]	75 [24]	80 [27]	85 [29]	90 [32]	95 [35]
				SENSIBLE CAPACITY					
				MBH [kW]	MBH [kW]	MBH [kW]	MBH [kW]	MBH [kW]	MBH [kW]
35 [1.5]	59 [15]	200.3 [58.7]	46.2 [7.9]	146.7 [43.0]	175.6 [51.5]	200.3 [59.8]	200.3 [72.7]	200.3 [79.0]	200.3 [85.2]
	63 [17]	223.8 [65.6]	49.8 [9.9]	130.4 [38.2]	159.4 [46.7]	188.8 [55.3]	217.3 [63.7]	223.8 [71.7]	223.8 [85.2]
	67 [19]	252.2 [73.9]	53.3 [11.8]	109.2 [32.0]	141.4 [41.4]	170.1 [49.8]	199.1 [58.3]	228.3 [66.9]	252.2 [75.1]
	71 [21.5]	278.3 [81.5]	56.8 [13.8]	—	118.1 [34.6]	150.3 [44.0]	178.7 [52.3]	207.2 [60.7]	236.2 [69.2]
	75 [24]	301.0 [88.2]	60.6 [15.9]	—	91.5 [26.8]	125.6 [36.8]	157.0 [46.0]	184.8 [54.2]	213.2 [62.5]
40 [4.5]	59 [15]	197.9 [58.0]	46.4 [8.0]	134.1 [39.3]	163.6 [47.9]	197.9 [59.9]	197.9 [67.1]	197.9 [74.0]	197.9 [80.8]
	63 [17]	200.6 [58.8]	51.3 [10.7]	119.8 [35.1]	149.5 [43.8]	178.6 [52.3]	200.6 [60.8]	200.6 [74.0]	200.6 [80.8]
	67 [19]	232.8 [68.2]	54.4 [12.4]	100.9 [29.6]	133.0 [39.0]	162.6 [47.6]	191.9 [56.2]	220.9 [64.7]	232.8 [73.1]
	71 [21.5]	262.6 [76.9]	57.7 [14.3]	—	112.2 [32.9]	144.3 [42.3]	173.1 [50.7]	202.4 [59.3]	232.1 [68.0]
	75 [24]	289.6 [84.9]	61.3 [16.3]	—	87.4 [25.6]	121.5 [35.6]	153.5 [45.0]	181.8 [53.3]	210.8 [61.8]
45 [7]	59 [15]	175.8 [51.5]	48.0 [8.9]	117.9 [34.5]	156.1 [45.7]	175.8 [53.2]	175.8 [60.6]	175.8 [67.9]	175.8 [75.1]
	63 [17]	172.2 [50.5]	53.1 [11.7]	106.2 [31.1]	136.2 [39.9]	165.9 [48.6]	172.2 [60.6]	172.2 [67.9]	172.2 [75.1]
	67 [19]	205.6 [60.2]	56.1 [13.4]	90.2 [26.4]	122.0 [35.7]	151.8 [44.5]	181.1 [53.0]	205.6 [61.8]	205.6 [75.1]
	71 [21.5]	240.3 [70.4]	59.1 [15.1]	—	103.6 [30.4]	135.7 [39.8]	165.2 [48.4]	194.8 [57.1]	223.8 [65.6]
	75 [24]	271.5 [79.5]	62.3 [16.8]	—	81.2 [23.8]	115.0 [33.7]	147.1 [43.1]	176.0 [51.6]	205.8 [60.3]
50 [10]	59 [15]	152.2 [44.6]	49.6 [9.8]	104.5 [30.6]	131.1 [38.4]	152.2 [46.1]	152.2 [53.7]	152.2 [61.2]	152.2 [68.7]
	63 [17]	152.2 [44.6]	49.6 [9.8]	89.8 [26.3]	119.8 [35.1]	152.2 [46.1]	152.2 [53.7]	152.2 [61.2]	152.2 [68.7]
	67 [19]	170.9 [50.1]	58.2 [14.6]	77.8 [22.8]	108.1 [31.7]	168.1 [40.5]	168.1 [49.2]	170.9 [61.2]	170.9 [68.7]
	71 [21.5]	209.9 [61.5]	60.8 [16.0]	—	92.3 [27.0]	154.2 [36.4]	154.2 [45.2]	183.5 [53.8]	209.9 [62.7]
	75 [24]	245.9 [72.1]	63.6 [17.6]	—	72.3 [21.2]	138.0 [31.1]	138.0 [40.4]	167.6 [49.1]	197.6 [57.9]

EVAPORATOR/AIR HANDLER RHGG-240 @ 8000 CFM [3776 L/s] 105°F (40.6°C) LIQUID TEMPERATURE AT TXV									
EVAP TEMP °F [°C]	EVAP INLET AIR WB °F [°C]	TOTAL CAPAC MBH [kW]	EVAP LVG AIR WB °F [°C]	EVAPORATOR ENTERING AIR DB—°F [°C]					
				70 [21]	75 [24]	80 [27]	85 [29]	90 [32]	95 [35]
				SENSIBLE CAPACITY					
				MBH [kW]	MBH [kW]	MBH [kW]	MBH [kW]	MBH [kW]	MBH [kW]
35 [1.5]	59 [15]	262.0 [76.8]	46.4 [8]	183.9 [53.9]	223.1 [65.4]	262.0 [76.8]	262.0 [76.8]	262.0 [76.8]	262.0 [76.8]
	63 [17]	292.7 [85.8]	49.9 [10]	161.1 [47.2]	200.3 [58.7]	239.5 [70.2]	278.7 [81.7]	292.7 [85.8]	292.7 [85.8]
	67 [19]	333.5 [97.7]	53.3 [12]	145.0 [42.5]	184.2 [54.0]	223.4 [65.4]	262.6 [76.9]	301.8 [88.4]	333.5 [97.7]
	71 [21.5]	354.0 [103.7]	57.5 [14]	—	154.6 [45.3]	193.8 [56.9]	233.0 [68.3]	272.2 [79.8]	311.4 [91.3]
	75 [24]	384.7 [112.7]	61.8 [16.5]	—	131.7 [38.6]	170.9 [50.1]	210.1 [61.6]	249.4 [73.1]	288.6 [84.6]
40 [4.5]	59 [15]	217.7 [63.8]	48.7 [9]	165.3 [48.4]	204.5 [59.9]	217.7 [63.8]	217.7 [63.8]	217.7 [63.8]	217.7 [63.8]
	63 [17]	252.8 [74.1]	51.9 [11]	144.6 [42.4]	183.8 [53.9]	223.0 [65.4]	252.8 [74.1]	252.8 [74.1]	252.8 [74.1]
	67 [19]	298.2 [87.4]	54.9 [13]	130.7 [38.3]	170.0 [49.8]	209.2 [61.3]	248.4 [72.8]	287.6 [84.3]	298.2 [87.4]
	71 [21.5]	322.8 [94.6]	59.0 [15]	—	142.5 [41.8]	181.7 [53.3]	220.9 [64.7]	260.1 [76.2]	299.3 [87.7]
	75 [24]	357.8 [104.9]	62.9 [17]	—	121.9 [35.7]	161.1 [47.2]	200.3 [58.7]	239.5 [70.2]	278.7 [81.7]
45 [7]	59 [15]	166.0 [48.6]	51.3 [11]	143.5 [42.1]	166.0 [48.6]	166.0 [48.6]	166.0 [48.6]	166.0 [48.6]	166.0 [48.6]
	63 [17]	204.9 [60.1]	54.2 [12]	125.1 [36.7]	164.3 [48.2]	203.5 [59.6]	204.9 [60.1]	204.9 [60.1]	204.9 [60.1]
	67 [19]	254.1 [74.5]	56.9 [14]	113.4 [33.2]	152.6 [44.7]	191.8 [56.2]	231.0 [67.7]	254.1 [74.5]	254.1 [74.5]
	71 [21.5]	282.7 [82.9]	60.7 [16]	—	127.4 [37.3]	166.6 [48.8]	205.8 [60.3]	245.0 [71.8]	282.7 [82.9]
	75 [24]	321.6 [94.3]	64.3 [18]	—	109.0 [31.9]	148.2 [43.4]	187.4 [54.9]	226.6 [66.4]	265.8 [77.9]
50 [10]	59 [15]	105.6 [30.9]	54.2 [12]	105.6 [30.9]	105.6 [30.9]	105.6 [30.9]	105.6 [30.9]	105.6 [30.9]	105.6 [30.9]
	63 [17]	148.1 [43.4]	56.8 [14]	102.8 [30.1]	142.0 [41.6]	148.1 [43.4]	148.1 [43.4]	148.1 [43.4]	148.1 [43.4]
	67 [19]	200.7 [58.8]	59.2 [15]	93.2 [27.3]	132.4 [38.8]	171.6 [50.3]	200.7 [58.8]	200.7 [58.8]	200.7 [58.8]
	71 [21.5]	233.1 [68.3]	62.7 [17]	—	109.4 [32.1]	148.6 [43.6]	187.8 [55.0]	227.0 [66.5]	233.1 [68.3]
	75 [24]	275.5 [80.7]	66.0 [19]	—	93.0 [27.3]	132.2 [38.8]	171.4 [50.2]	210.6 [61.7]	249.8 [73.2]

NOTES: 1. Total and sensible capacity is gross with no deduction for indoor blower motor heat. 2. Interpolation is permissible. Do not extrapolate.
3. Capacities are based on 105°F (40.6°C) liquid temperature at the TXV or about 95°F (35°C) dry bulb outdoor ambient.

AIRFLOW CORRECTION FACTORS

	RHGG-180 @ 6000 CFM [2832 L/s]										RHGG-240 @ 8000 CFM [3776 L/s]								
ACTUAL—CFM [L/s]	4400 [2077]	4800 [2265]	5200 [2454]	5600 [2643]	6000 [2832]	6400 [3020]	6800 [3209]	7200 [3398]	7600 [3587]	6400 [3020]	6800 [3209]	7200 [3398]	7600 [3587]	8000 [3776]	8400 [3964]	8800 [4153]	9200 [4342]	9600 [4531]	
TOTAL MBH	0.83	0.88	0.92	0.96	1.00	1.04	1.07	1.10	1.13	0.88	0.91	0.94	0.97	1.00	1.03	1.05	1.07	1.09	
SENSIBLE MBH	0.78	0.84	0.89	0.95	1.00	1.05	1.10	1.15	1.20	0.84	0.88	0.92	0.96	1.00	1.04	1.08	1.11	1.15	

NOTES: 1. Multiply correction factor times gross performance data.
2. Resulting sensible capacity cannot exceed total capacity.

[] Designates Metric Conversions

ELECTRICAL HEATER KIT CHARACTERISTICS

208/240 VOLT MODELS					
AIR HANDLER NOM. TONNAGE [kW]/HEATER NOM. 240V K.W. 1ST STAGE/TOTAL	AMPS HEATER ONLY	HEATER KIT CAPACITY KW INPUT	HEATING CAPACITY— MBH [kW]	MINIMUM CIRCUIT AMPACITY	MAXIMUM FUSE OR HACR BREAKER SIZE
7.5 [26], 10 [35]/20 [70]	42/48	15/20	51,200/68,300 [15/20]	66/72	70/80
7.5 [26], 15 [53]/30 [106]	60/70	21.6/28.8	73,700/98,300 [22/29]	88/100	90/100
7.5 [26], 20 [70]/40 [141]	83/96	30/40	102,400/136,500 [30/40]	117/132	125/150
15 [53], 10 [35]/20 [70]	42/48	15/20	51,200/68,300 [15/20]	83/88	90/90
15 [53], 15 [53]/30 [106]	60/70	21.6/28.8	73,700/98,300 [22/29]	105/115	110/125
15 [53], 20 [70]/40 [141]	83/96	30/40	102,400/136,500 [30/40]	134/148	150/150
480 VOLT MODELS					
7.5 [26], 10 [35]/20 [70]	24	20	68,300 [20]	36	40
7.5 [26], 15 [53]/30 [106]	35	28.8	98,300 [29]	50	50
7.5 [26], 20 [70]/40 [141]	48	40	136,500 [40]	66	70
15 [53], 10 [35]/20 [70]	24	20	68,300 [20]	44	45
15 [53], 15 [53]/30 [106]	35	28.8	98,300 [29]	58	60
15 [53], 20 [70]/40 [141]	48	40	136,500 [40]	74	80

NOTE: All kits have two stages of capacity, first stage heating is 50% of total capacity.

ELECTRICAL DATA TABLE

AIR HANDLER MOTOR			RATING PLATE AMPS	MOTOR LRA	MINIMUM CIRCUIT AMPACITY	RECOMMENDED MINIMUM Cu WIRE SIZE (3% VOLTAGE 75°C DROP) MAX. RUN IN FEET	MAX. FUSES BREAKERS
HP [W]	VOLTS	PHASE					
1 [746]	208-230	3Ø	4.0/3.6	23.9/21.6	15	#14/240	15
1 [746]	460	3Ø	1.8	10.8	15	#14/400	15
1 [746]	575	3Ø	1.4	8.4	15	#14/425	15
1 [746]	115-230	1Ø	16/8	96/48	20/15	#12/120 #14/180	20/15
1 1/2 [1119]	208-230	3Ø	5.7/5.2	34.5/31.2	15	#14/230	15
1 1/2 [1119]	460	3Ø	2.6	15.6	15	#14/300	15
1 1/2 [1119]	575	3Ø	2.1	12.6	15	#14/325	15
2 [1491]	208-230	3Ø	7.5/6.8	45.1/40.8	15	#14/165	15
2 [1491]	460	3Ø	3.4	20.4	15	#14/275	15
2 [1491]	575	3Ø	2.7	16.2	15	#14/300	15
2 [1491]	115-230	1Ø	24/12	144/72	30/15	#10/140 #14/120	30/15
3 [2237]	208-230	3Ø	10.6/9.6	64.1/58	15	#14/135	15
3 [2237]	460	3Ø	4.8	26.8	15	#14/230	15
3 [2237]	575	3Ø	3.9	23.4	15	#14/240	15
5 [3729]	208-230	3Ø	16.7/15.2	100.6/91	21/19	#10/240 #12/150	25/20
5 [3729]	460	3Ø	7.6	45.6	15	#14/185	15
5 [3729]	575	3Ø	6.1	36.6	15	#14/220	15
7 1/2 [5593]	208-230	3Ø	24.2/22.0	146/132	30/28	#10/150	30/30
7 1/2 [5593]	460	3Ø	11.0	66	15	#14/135	15
7 1/2 [5593]	575	3Ø	9.0	54	15	#14/150	15

NOTE: N.E.C., C.E.C. and local codes take precedence over suggested wire and fuse sizes.

[] Designates Metric Conversions

OPTIONAL HEATER KIT

COMPONENT CODE

BC BLOWER CONTACTOR
 HC HEATER CONTACTOR
 LBR LIMIT BYPASS RELAY
 LC LIMIT CONTROL

WIRE COLOR CODE

BK BLACK PU PURPLE
 BR BROWN RD RED
 BU BLUE WH WHITE
 GR GREEN YL YELLOW
 OR ORANGE

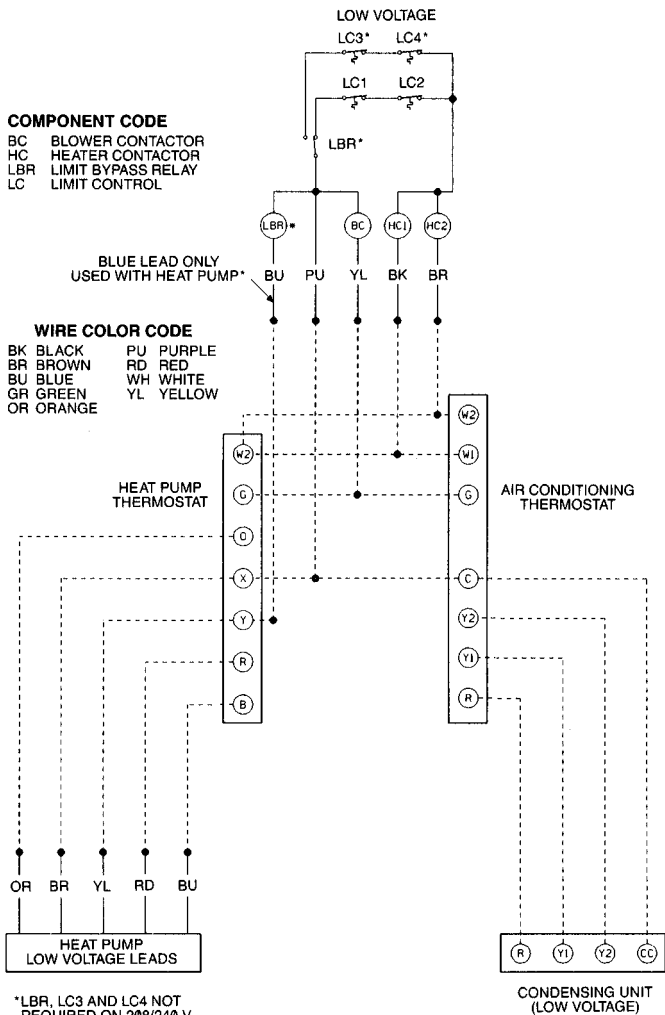

*LBR, LC3 AND LC4 NOT REQUIRED ON 208/240 V KITS RATED 20KW & 30KW OR KITS INSTALLED ON 15 TON OR 20 TON AIR HANDLERS

TYPICAL WIRING CONNECTIONS WITH DUAL CIRCUIT AIR HANDLER, ELECTRIC HEAT & TWO CONDENSING UNITS

120-208-230-460 VOLT AS REQUIRED

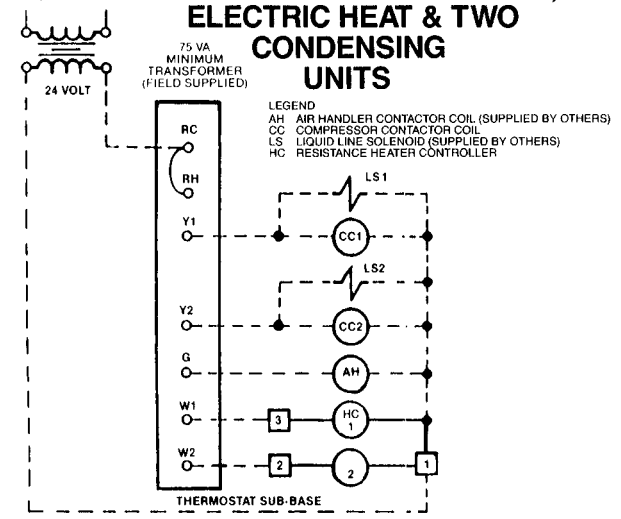

POWER WIRING

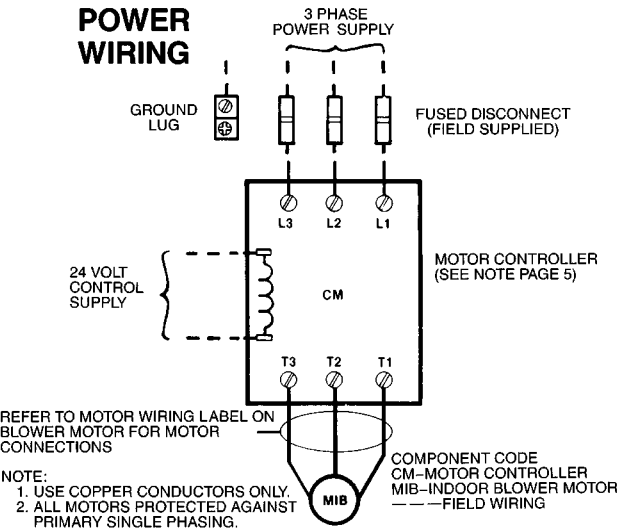

REFER TO MOTOR WIRING LABEL ON BLOWER MOTOR FOR MOTOR CONNECTIONS

NOTE:
 1. USE COPPER CONDUCTORS ONLY.
 2. ALL MOTORS PROTECTED AGAINST PRIMARY SINGLE PHASING.

AIR HANDLER ACCESSORIES

ACCESSORY DESCRIPTION	MODEL NUMBER	SIZES USED ON	NET WEIGHT (LBS) [kg]
Hot Water Coil	RXHC-C74W	090, 120	200 [91]
	RXHC-C76W	180, 240	200 [91]
Steam Coil	RXHC-C74S	090, 120	200 [91]
	RXHC-C76S	180, 240	200 [91]
Filter Frame Kit	RXHF-B74A	090, 120	90 [41]
	RXHF-B76A	180, 240	117 [53]
Inlet Grille Kit	RXHG-C74A	090, 120	9 [4]
	RXHG-C76A	180, 240	12 [5]
Discharge Grille Kit	RXHG-C74B	090, 120	15 [7]
	RXHG-C76B	180, 240	23 [10]
Discharge Plenum Kit	RXHL-C74B	090, 120	38 [17]
	RXHL-C76B	180, 240	62 [28]
Mixing Box	RXHM-BO74H	090, 120	120 [54]
	RXHM-BO76H	180, 240	195 [88]
Auxiliary Heater Kit	RXHE-DE020*A	090, 120	75 [34]
	RXHE-DE030*A	090, 120	75 [34]
	RXHE-DE040*A	090, 120	83 [38]
	RXHE-CE020*C	180, 240	90 [41]
	RXHE-CE030*C	180, 240	90 [41]
	RXHE-CE060*C	180, 240	98 [44]

RXHM MIXING BOX



RXHE ELECTRIC HEATER KIT

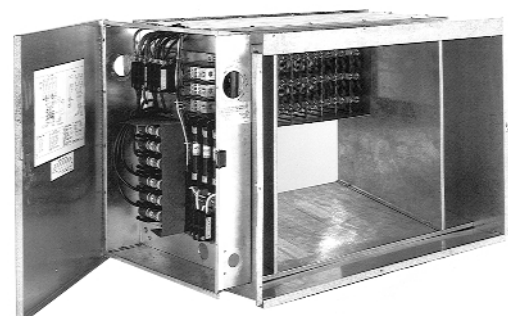

AIR HANDLER ACCESSORIES (con't)

HOT WATER OR STEAM COILS

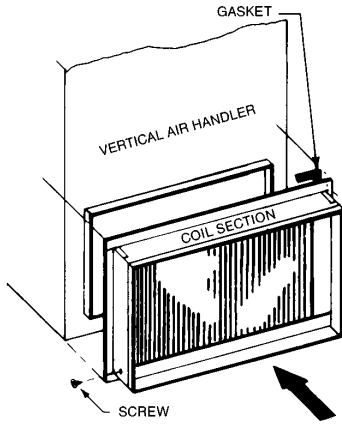

(090, 120) RXHC-C74W
RXHC-C74S
or
(180, 240) RXHC-C76W
RXHC-C76S

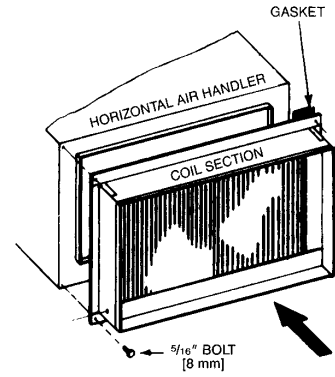

(090, 120) RXHC-C74W
RXHC-C74S
or
(180, 240) RXHC-C76W
RXHC-C76S

PHYSICAL SPECIFICATIONS

NOMINAL TONS [kW]	FINNED HEIGHT-IN. [mm]	FINNED LENGTH-IN. [mm]	FACE AREA FT ² [m ²]	CIRCUITS & TUBES HIGH
7 1/2 [26.38]-10 [35.17]	18 [457]	40 [1016]	5.0 [.46]	12
15 [52.75]-20 [70.34]	27 [686]	48 [1219]	9.0 [.84]	18

GROSS COIL PERFORMANCE

NOMINAL TONS [kW]	NOMINAL BTUH		NOMINAL CFM [L/s]	VELOCITY FPM
	STEAM	WATER		
7 1/2 [26.38]	242,500	185,000	3,000 [1416]	600
10 [35.17]	285,000	240,000	4,000 [1888]	800
15 [52.75]	465,000	375,000	6,000 [2832]	667
20 [70.34]	540,000	464,000	8,000 [3776]	888

1. Entering air temperature @ 60°F
2. Entering steam @ 5 PSIG
3. Entering water @ 200°F
4. Face velocity = $\frac{\text{CFM}}{\text{Face Area}}$

STEAM COIL

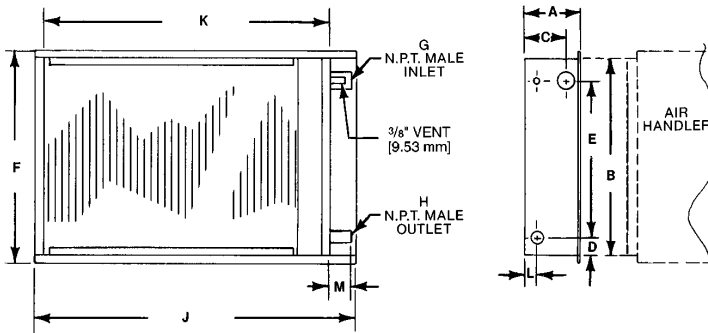

STEAM COIL DIMENSIONS—INCHES [mm]

MODEL	NOMINAL TONS [kW]	A	B	C	D	E	F	G	H	J	K	L	M
RXHC-C74	7 1/2 [26.38]-10 [35.17]	9 1/16 [230]	21 3/8 [543]	5 3/8 [137]	3 3/16 [81]	15 [381]	24 [610]	1 1/2 [38]	1 1/4 [32]	51 1/2 [1308]	47 5/8 [1210]	2 13/16 [71]	3 1/4 [83]
RXHC-C76S	15 [52.75]-20 [70.34]	9 1/16 [230]	30 7/8 [784]	5 3/8 [137]	3 3/16 [81]	24 [610]	35 [889]	2 [51]	1 1/2 [38]	59 1/2 [1511]	55 5/8 [1413]	2 13/16 [71]	3 1/2 [89]

HOT WATER COIL

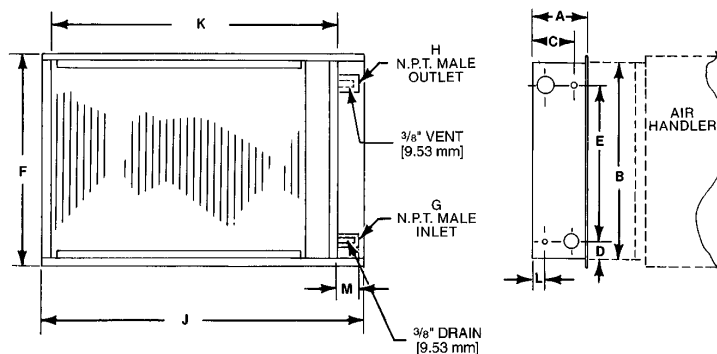

HOT WATER COIL DIMENSIONS—INCHES [mm]

MODEL	NOMINAL TONS [kW]	A	B	C	D	E	F	G	H	J	K	L	M
RXHC-C74W	7 1/2 [26.38]-10 [35.17]	9 1/16 [230]	21 3/8 [543]	5 3/8 [137]	3 3/16 [81]	15 [381]	24 [610]	1 1/4 [32]	1 1/4 [32]	51 1/2 [1308]	47 5/8 [1210]	2 13/16 [71]	3 [76]
RXHC-C76W	15 [52.75]-20 [70.34]	9 1/16 [230]	30 7/8 [784]	5 3/8 [137]	3 3/16 [81]	24 [610]	35 [889]	1 1/2 [38]	1 1/2 [38]	59 1/2 [1511]	55 5/8 [1413]	2 13/16 [71]	3 1/4 [83]

AIR HANDLER ACCESSORIES (con't)

HOT WATER COILS

**CURVE 2
HOT WATER COIL**

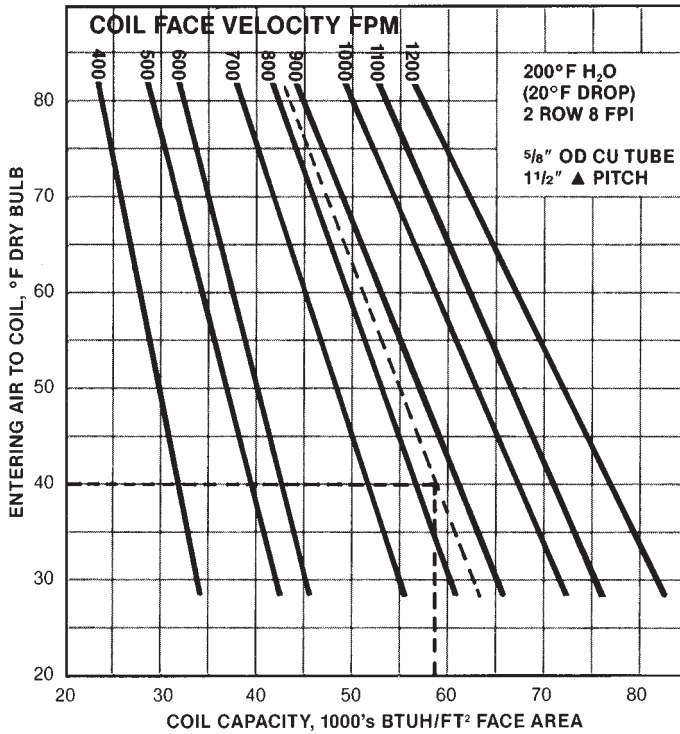

**CURVE 3
HOT WATER COIL WATER
PRESSURE DROP**

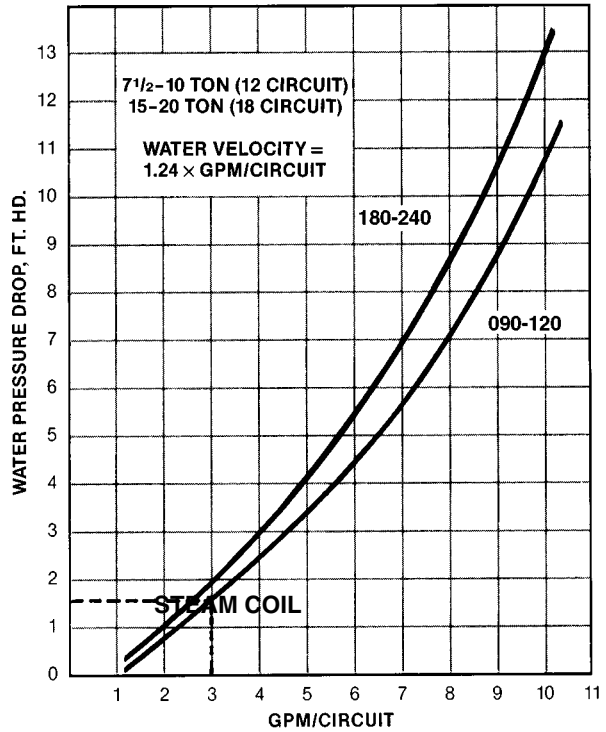

TABLE IV

Curve 2 ratings are based on 200°F entering water and 20°F temperature drop. For other conditions use the following correction factors:

ENTERING WATER °F	FACTOR	WATER TEMPERATURE DROP °F	FACTOR
220	1.14	10	1.030
210	1.07	15	1.015
200	1.00	20	1.000
190	.98	25	.985
180	.93	30	.970

BASIC FORMULA:

$$\text{Air Temperature Rise, } ^\circ\text{F} = \frac{\text{BTUH}}{1.08 \times \text{CFM}}$$

$$\text{Water Temperature Drop, } ^\circ\text{F} = \frac{\text{BTUH}}{500 \times \text{GPM}}$$

HOT WATER COIL SELECTION:

Specified:

Entering Air Temp. @ 40°F
 5000 CFM @ 6000 Ft. Elevation
 220°F Entering Water Temp. @ 36 GPM

Select 10 Ton Nominal Coil:

Face Area = 5 Ft²
 Circuits = 12

Determine Coil Performance:

From Table I (page 21), Altitude and Temperature Correction Factor = 1.19
 Std. CFM = 5000/1.19 = 4202
 Face Velocity = 4202/5 = 840 FPM
 From Curve 2, BTUH/Ft² = 57,500
 Coil Capacity = 5 x 58,000 = 287,500 BTUH
 Water Temp. Drop = 290,000/(500 x 36) = 16.1°F
 From Table IV, Water Temp. Factor = 1.14
 From Table IV, Water Temp. Drop Factor = 1.012
 Total Capacity = 287,500 x 1.14 x 1.015 = 334,570 BTUH
 From Curve 3, Water Pressure Drop 36 GPM/12 Circuits = 3 GPM/Circuit = 1.6 FT. HD.
 From Table II, Air Side Pressure Drop = .38" H₂O

AIR HANDLER ACCESSORIES (con't)

STEAM COILS AIRFLOW

TABLE I
ALTITUDE AND TEMPERATURE CORRECTION FACTOR TABLE

AIR TEMP. (F)	ALTITUDE IN FEET ABOVE SEA LEVEL															
	0	500	1000	1500	2000	2500	3000	3500	4000	4500	5000	6000	7000	8000	9000	10,000
0	.87	.89	.91	.92	.94	.96	.98	.99	1.01	1.03	1.05	1.09	1.13	1.17	1.22	1.26
40	.94	.96	.98	1.00	1.02	1.04	1.06	1.08	1.10	1.12	1.14	1.19	1.23	1.28	1.32	1.36
70	1.00	1.02	1.04	1.06	1.08	1.10	1.12	1.14	1.19	1.18	1.20	1.25	1.30	1.35	1.40	1.45
100	1.06	1.08	1.10	1.12	1.14	1.16	1.19	1.21	1.23	1.25	1.28	1.33	1.38	1.43	1.48	1.54
120	1.09	1.12	1.14	1.16	1.18	1.20	1.23	1.25	1.28	1.30	1.32	1.38	1.43	1.48	1.53	1.58

EXAMPLE: Determine Equivalent "Standard Air" for use in System Performance Calculations:

$$\text{Standard Air} = \frac{\text{Specified CFM}}{\text{Correction Factor}}$$

TABLE II
AIR FRICTION LOSS

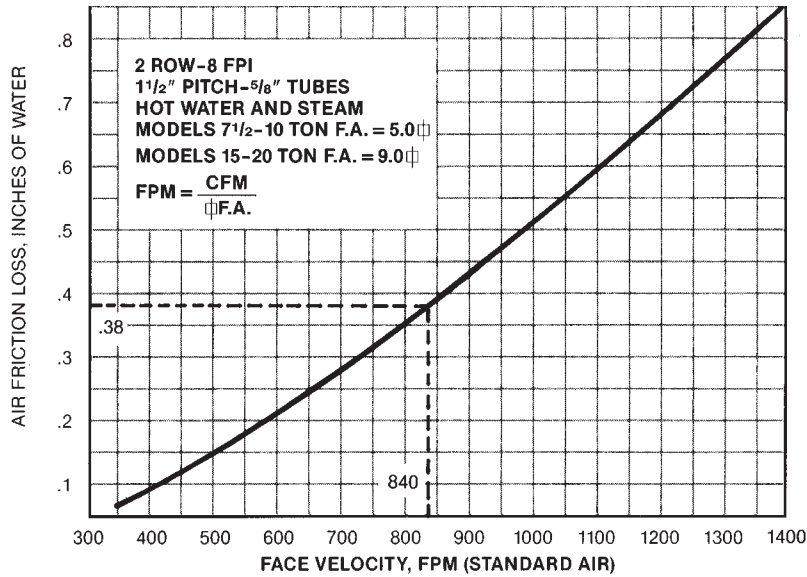

STEAM COILS

CURVE 1
STEAM COIL CAPACITY

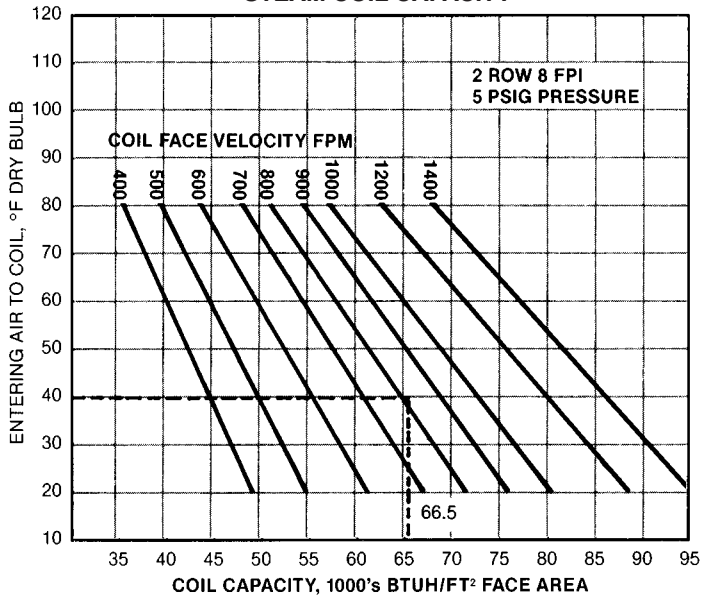

TEMPERATURE OF STEAM AT VARIOUS PRESSURES

Approximate Gauge Pressure (lbs.)	2	5	10	15	20	30
Temperature °F	218	227	240	250	259	275

TABLE III

Steam Coil Capacity, factors are based on 5 PSIG Steam Pressure. For other conditions use the adjacent correction factors.

STEAM PR., PSIG	FACTOR
2	.96
5	1.00
10	1.06
15	1.11
20	1.16
30	1.24

BASIC FORMULA:

$$\text{Air Temperature Rise, } ^\circ\text{F} = \frac{\text{BTUH}}{1.08 \times \text{CFM}}$$

STEAM COIL SELECTION:

Specified:

Steam @ 30 PSIG
Entering Air Temp. @ 40°F Dry Bulb
5000 CFM @ 6000 Ft. Elevation

Select 10 Ton Nominal Coil:

Face Area = 5 Ft²
Circuits = 12

Determine Coil Performance:

From Table I (page 21), Altitude and Temperature Correction Factor = 1.19

Std. CFM = 5000/1.19 = 4202

Face Velocity = 4202/5 = 840 FPM

From Curve 1, BTUH/Ft = 66,500

Coil Capacity = 5 x 65,000 = 325,000 BTUH

From Table III, Steam Correction Factor = 1.24

Total Coil Capacity = 1.24 x 325,000 = 403,000 BTUH

Air Temp. Rise = 403,000/(1.08 x 4202) = 90.85°F

From Table II, Air Side Pressure Drop = .38" H₂O

AIR HANDLER ACCESSORIES (con't)

FILTER RACK

The filter rack accessory can be connected directly to the hot water/steam coil accessory. The filter rack accessory is **ONLY** needed when hot water steam coils are used.

MODEL NO.	AIR HANDLER SIZES USE ON	IN. [mm]					
		A	B	C	D	E	F
RXHF-B74A	090, 120	51 1/2 [1308]	24 [610]	25 1/8 [638]	47 3/8 [1203]	19 7/8 [505]	2 1/16 [52]
RXHF-B76A	180, 240	59 1/2 [1511]	34 1/2 [876]	27 [686]	55 1/2 [1410]	30 1/2 [775]	2 [51]

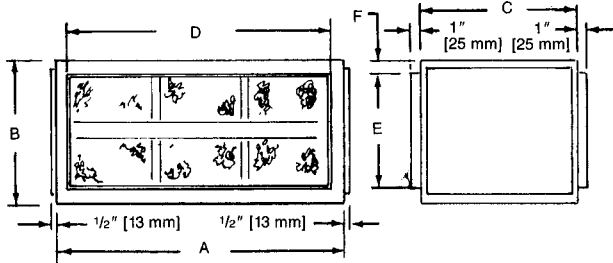

MODEL NO.	FILTER SIZE (QTY.) TYPE
RXHF-B74A	16x20x1 (4) Disposable 20x20x1 (2) Disposable
RXHF-B76A	20x25x1 (6) Disposable

FILTER PRESSURE DROP:

MODEL NO.	CFM [L/s] x 1000 [472]									
	2	3	4	5	6	7	8	9	10	
RXHF-B74A	.01 [2]	.02 [4]	.03 [7]	.07 [16]	.10 [22]	.15 [33]	—	—	—	—
RXHF-B76A	—	—	—	—	.05 [11]	.06 [13]	.10 [22]	.12 [27]	.15 [33]	—

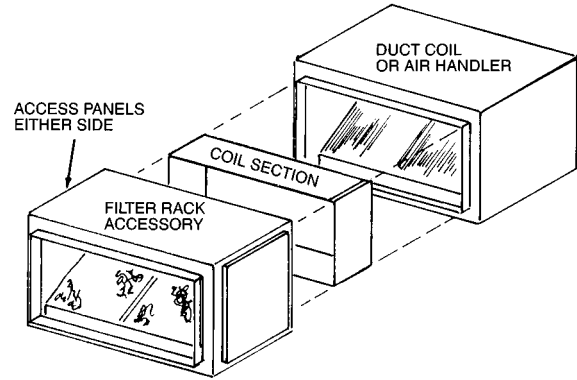

UNIT WITH ACCESSORIES

7.5 THROUGH 20 NOMINAL TONS [26 THROUGH 70 kW]

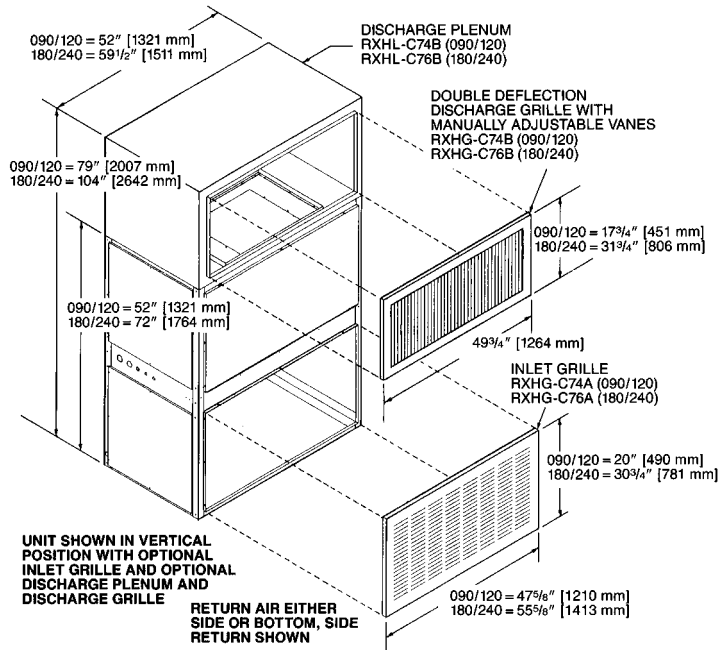

DOUBLE DEFLECTION DISCHARGE GRILLE

MODEL NO.	AIR HANDLER SIZES USED ON	NOMINAL CFM [L/s]	FT. [m] OF THROW
RXHG-C74B	090	3000 [1416]	0° DEFLECTION - 43' [13.1]
			22° DEFLECTION - 37' [11.3]
			45° DEFLECTION - 22' [6.7]
RXHG-C76B	120	4000 [1888]	0° DEFLECTION - 53' [16.2]
			22° DEFLECTION - 46' [14]
			45° DEFLECTION - 27' [8.2]
RXHG-C76B	180	6000 [2831]	0° DEFLECTION - 52' [15.8]
			22° DEFLECTION - 36' [11]
			45° DEFLECTION - 18' [5.5]
RXHG-C76B	240	8000 [3775]	0° DEFLECTION - 65' [19.8]
			22° DEFLECTION - 45' [13.7]
			45° DEFLECTION - 22' [6.7]

[] Designates Metric Conversions

TYPICAL APPLICATION

7.5, 10, 15 AND 20 NOMINAL TONS [26, 35, 53 AND 70 kW]

OPTIONAL ELECTRICAL HEATER KIT SHOWN INSTALLED IN HORIZONTAL POSITION AND CONNECTED DIRECTLY TO THE AIR HANDLER. THE HEATER KIT MAY ALSO BE INSTALLED WITH THE AIR HANDLER SET IN THE VERTICAL POSITION. IN EITHER POSITION THE HEATER KIT CONTROL COMPARTMENT MUST BE ON THE LEFT SIDE FACING THE AIR DISCHARGE OPENING.

AUXILIARY HEATER KIT

MODEL NO.	AIR HANDLERS SIZES USED ON	IN. [mm]	
		A	B
RXHE-DE***A	090, 120	20 [508]	20 [508]
RXHE-CE***C	180, 240	36 [914]	24 [610]

THE BOTTOM OF THE AIR HANDLER SHOULD BE SLOPED IN TWO PLANES THAT PITCH THE CONDENSATE TO THE DRAIN CONNECTION. THE DRAIN PAN SHOULD NOT LEAVE PUDDLES LARGER THAN 2 INCHES IN DIAMETER AND 1/8 INCH DEEP FOR MORE THAN 3 MINUTES.

FOUR HEAVY GAUGE ANGLES ARE FURNISHED (SHIPPED LOOSE) FOR SUSPENDING UNITS FROM ALL FOUR CORNERS, MINIMUM OF 1/2" [13] SUPPORT RODS ARE RECOMMENDED. IF ALL-THREAD IS USED, IT IS ALSO RECOMMENDED THAT TWO NUTS AND TWO LOCKWASHERS BE TIGHTENED SECURELY AGAINST THE SUSPENSION ANGLES.

WHEN HOT WATER OR STEAM COIL, MIXING BOX OR DISCHARGE AIR PLENUM ACCESSORIES ARE REQUIRED, UNITS CANNOT BE SUSPENDED AS ILLUSTRATED, AN ALTERNATE SUSPENSION METHOD SUCH AS ANGLES OR CHANNELS (FIELD SUPPLIED) SHOULD BE LOCATED UNDER UNIT. (SHOWN BELOW)

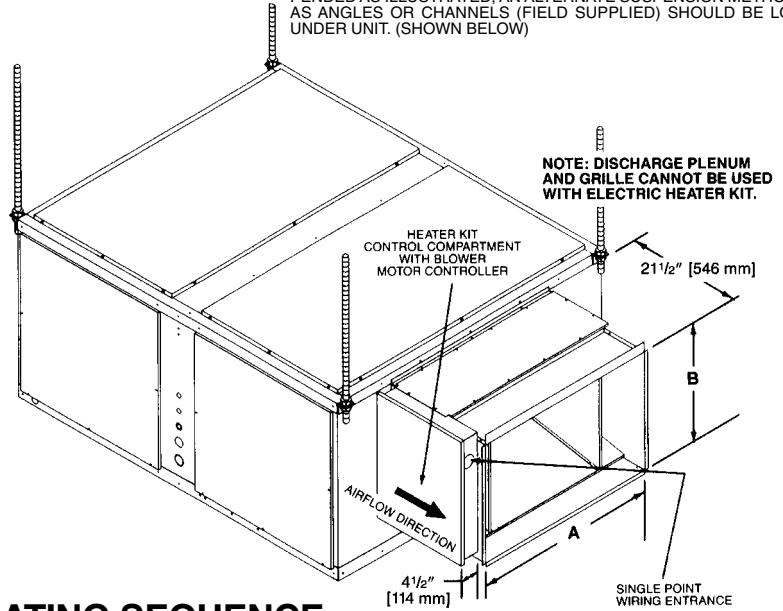

MIXING BOX ACCESSORY—OPERATING SEQUENCE

COOLING SEASON—Thermostat set at “Cool” and “Fan Auto,” outside air damper goes to “minimum fresh air” position when cooling thermostat closes, energizing mechanical cooling. When cooling thermostat is satisfied, mechanical cooling is de-energized, and outside air damper closes.

INTERMEDIATE SEASON—Same as for cooling season, except that cooling thermostat closes, starting indoor blower motor, the enthalpy control, mounted on outside air, determines if “free” cooling or mechanical cooling should be utilized. If outside air conditions are suitable for cooling, the mechanical cooling remains off and the mixed air controller modulates the damper motor to assume the proper damper position to maintain mixed air setting. If outside conditions

are not suitable for cooling, then the dampers go to “minimum fresh air” position and mechanical cooling is energized.

HEATING SEASON—Damper always stays at “minimum fresh air” position while fan motor is operating. Outside air damper closes when blower motor is off. “Minimum fresh air” position must not allow mixed air temperatures to air handler below 50°F. [10°C] during heating seasons.

CAUTION: IT IS NOT RECOMMENDED THAT HOT WATER OR STEAM COILS BE USED WITH THE MIXING BOX ACCESSORY WITHOUT A SUITABLE FREEZE-STAT TO PREVENT THE POSSIBILITY OF FREEZING THE COIL.

MIXING BOX

[] Designates Metric Conversions

MODEL NO.	AIR HANDLER SIZES USED ON	FLANGED DUCT OPENINGS		IN. [mm]
		LENGTH IN. [mm]	WIDTH IN. [mm]	“X”
RXHM-AB74H	090, 120	42 [1067]	16 7/8 [454]	27 [686]
RXHM-AB76H	180, 240	48 3/8 [1229]	22 [559]	32 [813]

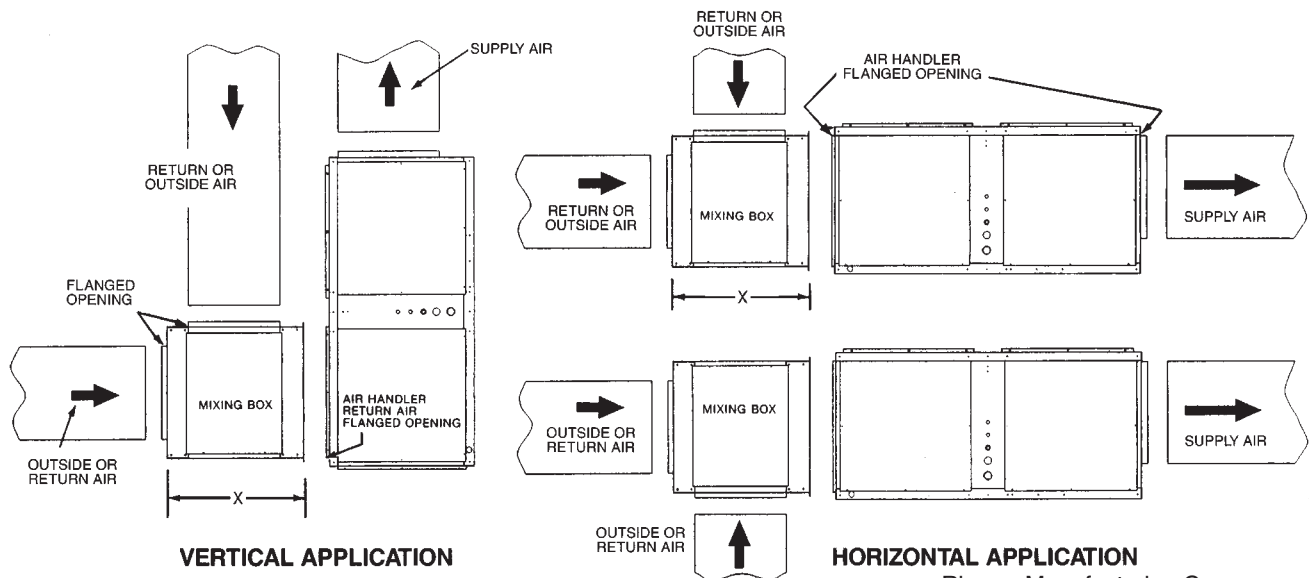

TYPICAL PIPING RECOMMENDATIONS

INDOOR COIL ABOVE OUTDOOR UNIT

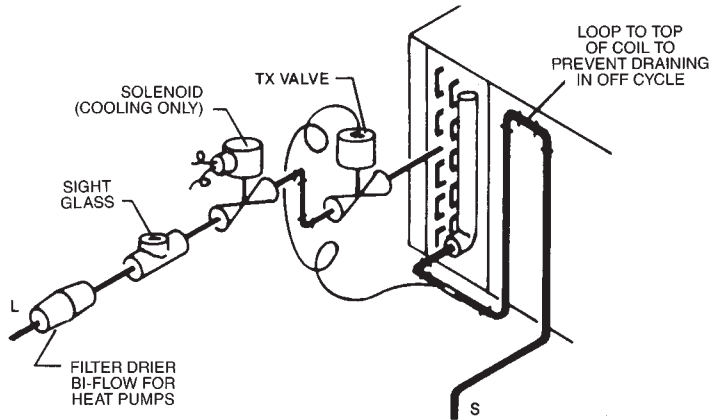

INDOOR COIL BELOW OUTDOOR UNIT

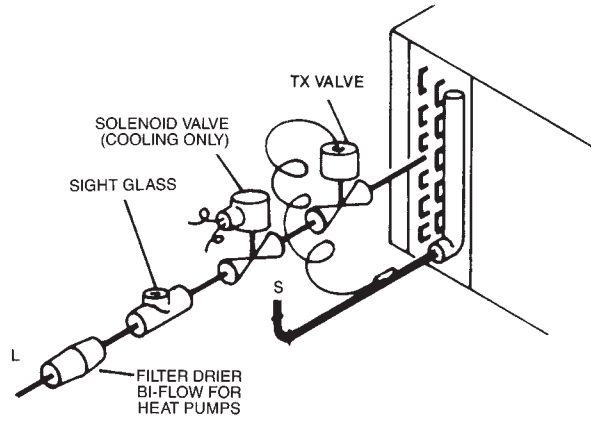

NOTE: PIPING ACCESSORIES SHOWN SHOULD BE MOUNTED AS CLOSE TO AIR HANDLING UNIT AS POSSIBLE.

The 7.5 [26 kW] through 20 [70 kW] Air Handlers are designed as two (2) circuit, full face equal distribution coils. As shipped from the factory, the suction and liquid lines are dual circuits. Copper fittings are supplied in the unit to field manifold the suction and liquid lines for single circuit.

NOTE: The expansion valve bulbs must be secured to the corresponding suction lines. The circuits are marked accordingly. See illustration under Typical Piping recommendations for additional information.

When dual straight cool condensing units are used refer to the refrigerant piping size charts for the individual condensing unit piping.

REFRIGERANT PIPING (See Tables at Right)

The following will be of help in accomplishing a successful installation.

1. Size liquid line for no more than 30 PSIG [207 kPa] pressure drop.
2. Size suction lines for no more than 2°F [1.1°C] loss which corresponds to approximately 3 PSIG [21 kPa] pressure drop.
3. When indoor unit is installed below outdoor unit, do not exceed the recommended vapor line O.D. This will insure adequate velocities for proper oil return.
4. Install strainer-drier and sight glass in liquid line.
5. Pitch all horizontal suction lines downward in the direction of flow for cooling only applications.
6. Locate the outdoor unit and indoor unit as close together as possible to minimize piping runs.
7. A liquid line solenoid installed just ahead of the expansion valve is recommended for cooling only applications. Be sure condensing unit is suitable for pump down.
8. Piping runs between condenser and evaporator not to exceed 150' [46 m] linear length (90' [27 m] linear length for heat pumps).

NOTE: Refer to suction and liquid line pressure drop charts found in condensing unit and remote heat pump literature.

CONDENSATE DRAIN PIPING

- Consult local codes or ordinances for specific requirements regarding condensate drain.
- Condensate drain is open to atmosphere and must be trapped. Trap must be at least 3 inches [76 mm] deep and made of flexible material or fabricated to prevent freeze-up.
- Pitch the drain line at least 1/4 inch [6 mm] per foot away from the drain pan.
- Do not reduce the drain line size from the connection size provided on the unit.
- Do not connect the drain line to a closed sewer line.

PIPING SIZES 090 & 120				
LINEAR LENGTH, FT. [m]	LIQUID LINE O.D., IN. [mm]		SUCTION LINE O.D., IN. [mm]	
	090	120	090	120
0-50 [0-15]	1/2 [13]	5/8 [16]	1 1/8 [29]	1 3/8 [35]
51-100* [16-30]	1/2 [13]	5/8 [16]	1 3/8 [35]	1 5/8 [41]
101-150 [31-46]	1/2 [13]	5/8 [16]	1 3/8 [35]	1 5/8 [41]

*For cooling only, refer to remote heat pump literature for piping recommendations.

PIPING SIZES 180 & 240				
LINEAR LENGTH, FT. [m]	LIQUID LINE O.D., IN. [mm]		SUCTION LINE O.D., IN. [mm]	
	180	240	180	240
0-50 [0-15]	3/4 [19]	7/8 [22]	1 3/8 [35]	1 5/8 [41]
51-100 [16-30]	3/4 [19]	7/8 [22]	1 5/8 [41]	2 1/8 [54]
101-150 [31-46]	3/4 [19]	7/8 [22]	2 1/8 [54]	2 1/8 [54]

EQUIVALENT LENGTH, FT. [m] OF STRAIGHT TYPE "L" TUBING FOR NON-FERROUS VALVES AND FITTINGS (BRAZED)						
TUBE SIZE INCHES [mm] O.D.	SOLENOID VALVE	ANGLE VALVE	SHORT RADIUS ELL	LONG RADIUS ELL	TEE LINE FLOW	TEE BRANCH FLOW
1/2 [13]	70 [21]	24 [7.3]	4.7 [1.4]	3.2 [.98]	1.7 [.52]	6.6 [2.0]
5/8 [16]	72 [22]	25 [7.6]	5.7 [1.7]	3.9 [1.2]	2.3 [.70]	8.2 [2.5]
3/4 [19]	75 [23]	25 [7.6]	6.5 [1.5]	4.5 [1.4]	2.9 [.88]	9.7 [3.0]
7/8 [22]	78 [24]	28 [8.5]	7.8 [2.4]	5.3 [1.6]	3.7 [1.1]	12.0 [3.7]
1 1/8 [29]	87 [27]	29 [8.8]	2.7 [0.8]	1.9 [.58]	5.2 [1.6]	8.0 [2.4]
1 3/8 [35]	102 [31]	33 [10]	3.2 [.98]	2.2 [.67]	6.9 [2.1]	10.0 [3.0]
1 5/8 [41]	115 [35]	34 [10.4]	3.8 [1.2]	2.6 [.79]	8.7 [2.7]	12.0 [3.7]
2 1/8 [54]	141 [43]	39 [11.8]	5.2 [1.6]	3.4 [1.0]	12.0 [3.7]	16.0 [4.9]

[] Designates Metric Conversions

OPERATING SEQUENCE

NOTE: Please refer to specification sheets covering RAWD- and RAWE- condensing units and RPWC- and RPWE- Remote Heat Pumps for operating sequence.

GUIDE SPECIFICATIONS

Furnish and install as shown on the drawing Rheem Model _____ draw through air handler suitable for both horizontal and vertical applications. The entire assembly shall be UL and cUL listed with the cooling (and heat pump heating) capacity A.R.I. Certified.

DRIVE PACKAGE—A complete drive package shall be factory or field installed. Package shall consist of a 3450 RPM dual voltage, single phase open drip proof motor or a 3 phase 1750 RPM open drip proof internally protected motor, not requiring an external starter. Variable pitch motor sheave, fixed pitch fan sheave, and belt.

COILS—Coils shall be fabricated of 3/8" [10 mm] O.D. seamless copper tubing expanded into aluminum fins. All coils shall be submitted to an air pressure test of up to 300 PSIG [2068 kPa] under water after fabrication and dehydrated prior to assembly in unit. Units shall be shipped with a nitrogen holding charge. Airflow shall be draw through design providing uniform air distribution across the coil surface.

BLOWER, BEARINGS AND SHAFT—Fans shall be a double width, double inlet, forward curve, centrifugal type, statically and dynamically balanced, and constructed of galvanized steel. They shall be mounted on 3/4" [19 mm] = 7.5 ton [26 kW] & 10 ton [35 kW], 1" [25 mm] = 15 ton [53 kW] & 20 ton [70 kW] diameter solid shafts made of high carbon steel, centerless ground and polished, supported by resilient mounted sealed bearings.

DRAIN PAN—The drain pan shall be manufactured of zinc coated steel. The pan shall have internally threaded pipe size drain connections and shall be designed to accept condensate in either horizontal or vertical type applications on either side of unit.

FILTERS—Filter mounting hardware shall be designed to accept up to 2" [51 mm] filters for field replacement. One inch [25 mm] throw away filters shall be furnished with the unit.

CABINET—Cabinets shall be manufactured of galvanized steel subjected to multi-stage cleaning and finished with powder coat paint. Units shall have removable service access panels on each side and top.

INSULATION—Cabinets shall be insulated with 1/2" [13 mm] by 1 1/2 pound [.68 kg] density fiberglass insulation coated with neoprene and bonded to the cabinet surface with a U.L. approved adhesive. Insulation shall have fire retarding characteristics in accordance with smoke developed rating not to exceed 50 and flame spread rating of 25 per Underwriters Laboratories testing procedures.

FACTORY TESTING—In addition to the pre-assembly testing mentioned above, each coil shall be leak tested with a mixture of dry air and R-22 after assembly into the unit. While under pressure, the coil shall be leak tested using an Electronic Leak Detector at a setting of 1/2 oz. [14 g] per year sensitivity.

ELECTRIC HEATERS—UL and cUL listed electric heater kits shall be available in a wide range of capacities. All kits shall offer two stages of capacity, blower motor controller and single point connection. Heater kits shall be available for installation directly on the supply fan discharge for either horizontal or vertical application.

MIXING BOX—Mixing box accessory shall be available for mixing return air with outside air before entering the air handler. The accessory shall include both return and outside air dampers and economizer controls factory mounted. Economizer controls shall include enthalpy and mixed air sensors and damper motors. Mixing box accessory shall be available for installation to the return air section of the air handler for either horizontal or vertical applications.

DISCHARGE PLENUM AND GRILLE—Shall be available for vertical application. Discharge grille shall provide manually adjustable double deflection discharge vanes.

RETURN AIR GRILLES—Shall be provided for vertical return applications.

HOT WATER OR STEAM COILS—Shall be available for field installation. All coils shall be tested to 300 psi. Coils shall be available for either horizontal or vertical air handler applications.

[] Designates Metric Conversions

GENERAL TERMS OF LIMITED WARRANTY*

Rheem will furnish a replacement for any part of this product which fails in normal use and services within the applicable periods stated below, in accordance with the terms of the limited warranty.

Any PartOne (1) Year

*For Complete Details of the Limited Warranty, Including Applicable Terms and Conditions, See Your Local Installer or Contact the Manufacturer for a Copy.

NOTES

NOTES

Before proceeding with installation, refer to installation instructions packaged with each model, as well as complying with all Federal, State, Provincial, and Local codes, regulations, and practices.

**RHEEM
AIR CONDITIONING
DIVISION**

5600 Old Greenwood Road, Fort Smith, Arkansas 72908



"In keeping with its policy of continuous progress and product improvement, Rheem reserves the right to make changes without notice."