

# SUBMITTAL SHEET FOR (-)HGG- SERIES 7.5, 10, 15 & 20 NOMINAL TON [26, 35, 53 & 70 kW] AIR HANDLER

JOB NAME \_\_\_\_\_ MODEL NO. \_\_\_\_\_  
 CONTRACTOR \_\_\_\_\_ OUTDOOR UNIT MODEL NO. \_\_\_\_\_  
 ENGINEER \_\_\_\_\_ LOCATION \_\_\_\_\_  
 SUBMITTED FOR  APPROVAL  RECORD ORDER NO. \_\_\_\_\_  
 DATE \_\_\_\_\_

## UNIT DATA

### COOLING PERFORMANCE

TOTAL CAPACITY\* ..... MBH [kW]  
 SENSIBLE CAPACITY\* ..... MBH [kW]  
 OUTDOOR DESIGN TEMP. .... °F [°C] DB  
 TOTAL SUPPLY AIR ..... CFM  
 TEMP. OF AIR ENTERING  
 EVAPORATOR COIL ..... °F DB  
 ..... °F WB  
 POWER INPUT REQUIREMENT ..... kW  
 (\*uses blower motor heat)

### HEATING PERFORMANCE

TOTAL CAPACITY\* ..... MBH [kW]  
 OUTDOOR DESIGN TEMP. .... °F [°C] DB  
 TEMP. OF AIR ENTERING  
 EVAPORATOR COIL ..... °F [°C] DB  
 ELECTRIC HEAT CAPACITY ..... kW  
 POWER INPUT REQUIREMENT ..... kW  
 (\*uses blower motor heat)

### SUPPLY AIR BLOWER PERFORMANCE

TOTAL AIR SUPPLY ..... CFM [L/s]  
 TOTAL RESISTANCE EXTERNAL  
 TO UNIT ..... IWG  
 BLOWER SPEED ..... RPM  
 POWER OUTPUT REQUIREMENT .. BHP  
 MOTOR RATING ..... HP [W]  
 POWER INPUT REQUIREMENT ..... kW

### ELECTRICAL DATA

POWER SUPPLY ..... 208-230V/1PH/60Hz \_\_\_\_\_  
 TOTAL UNIT AMPACITY ..... AMPS  
 MINIMUM WIRE SIZE ..... AWG  
 MAXIMUM OVERCURRENT DEVICE  
 FUSES/HACR BREAKER ..... AMPS

### CLEARANCES

SERVICE ACCESS SIDES 36" [914 mm]

## FEATURES FOR (-)HGG- AIR HANDLERS 7.5, 10, 15 AND 20 NOMINAL TON [26, 35, 53 & 70 kW]

- Low profile
- Install horizontally or vertically as shipped from the factory
- Powder coat painted cabinet
- Optional high static drive packages deliver nominal CFM up to 2" E.S.P.
- Standard filter rack with 1" throwaway filters (rack will accept field supplied 2" filter)
- Standard thermal expansion valves, two per unit
- Two circuit, interlaced copper tube/aluminum fin coils to provide full face cooling at part load
- Flexible field connections: refrigerant piping, condensate piping, power and control wiring from either side of unit
- Easy service access from top or either side
- 10 ton, 3 phase, air handler is A.R.I. rated and certified for 7.5 and 10 ton straight cooling or heat pump operation
- Certified and rated under ARI Standards 340 & 360
- U.L. listed
- Factory run tested prior to shipment
- Factory one (1) year limited warranty on parts

## FIELD INSTALLED ACCESSORIES

- Hot Water Coil .....   
 Steam Coil .....   
 Filter Frame Kit .....   
 (used with H.W. or steam coil only)  
 Inlet Grille Kit .....   
 Discharge Grille Kit .....   
 Discharge Plenum Kit.....   
 Mixing Box .....   
 \_\_\_\_\_ kW Auxiliary Electric Heater Kit.....



## UNIT DIMENSIONS

### 7.5 AND 10 NOMINAL TONS [26 & 35 kW]

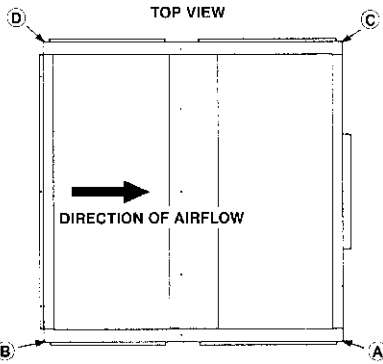

MODEL	REFRIGERANT STUB SIZES (IN.) [mm]			
	DUAL LIQ.	DUAL SUC.	SINGLE LIQ.	SINGLE SUC.
7.5 Ton	1/2, 1/2 [13, 13]	7/8, 7/8 [22, 22]	1/2 [13]	1 1/8 [29]
10 Ton	1/2, 1/2 [13, 13]	7/8, 7/8 [22, 22]	5/8 [16]	1 3/8 [35]

MODEL	CORNER WEIGHTS (LBS.) [kg]				TOTAL WEIGHT
	A	B	C	D	
7.5 Ton	88 [40]	78 [35]	87 [39]	77 [35]	330 [150]
10 Ton	93 [42]	82 [37]	92 [42]	80 [36]	347 [157]

RETURN AIR OPENINGS = 47 3/8" [1203] WIDTH x 19 7/8" [505] HEIGHT

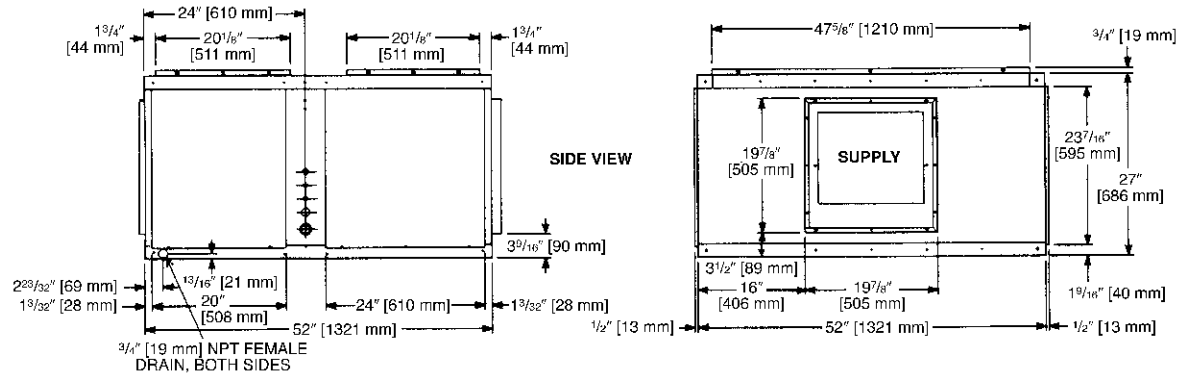

### 15 AND 20 NOMINAL TONS [53 & 70 kW]

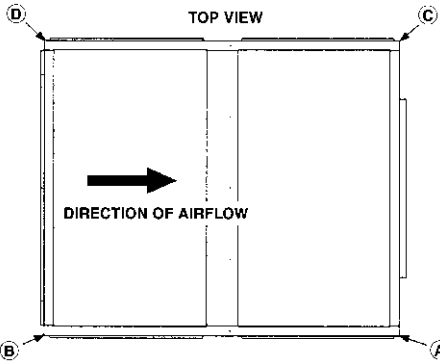

MODEL	REFRIGERANT STUB SIZES (IN.) [mm]			
	DUAL LIQ.	DUAL SUC.	SINGLE LIQ.	SINGLE SUC.
15 Ton	1/2, 1/2 [13, 13]	1 1/8, 1 1/8 [29, 29]	5/8 [16]	1 5/8 [41]
20 Ton	5/8, 5/8 [16, 16]	1 3/8, 1 3/8 [35, 35]	7/8 [22]	1 5/8 [41]

MODEL	CORNER WEIGHTS (LBS.) [kg]				TOTAL WEIGHT
	A	B	C	D	
15 Ton	144 [65]	127 [58]	117 [53]	105 [48]	495 [225]
20 Ton	159 [72]	142 [64]	129 [59]	115 [52]	545 [247]

RETURN AIR OPENINGS = 55 1/2" [1410] WIDTH x 30 9/16" [776] HEIGHT

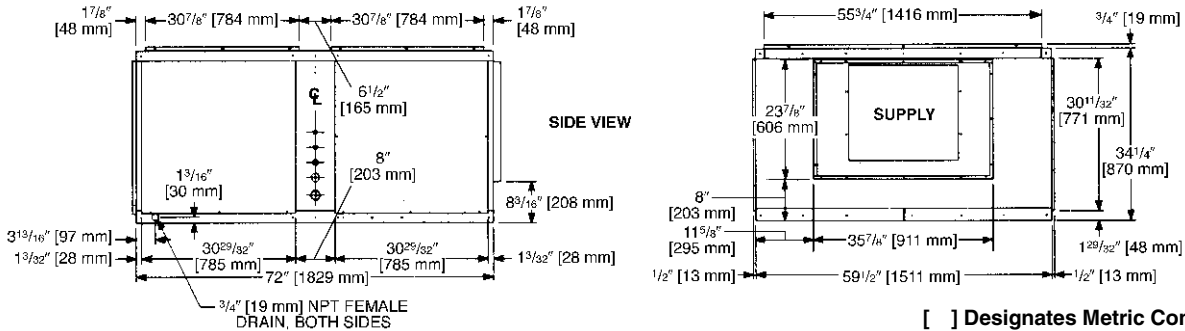

[ ] Designates Metric Conversions

**Before proceeding with installation, refer to installation instructions packaged with each model, as well as complying with all Federal, State, Provincial, and Local codes, regulations, and practices.**

RHEEM  
MANUFACTURING  
COMPANY  
5600 Old Greenwood Road, Fort Smith, Arkansas 72908

"In keeping with its policy of continuous progress and product improvement, Rheem reserves the right to make changes without notice."