

# PACKAGE AIR CONDITIONING UNITS

FORM NO. S22-936 REV. 5  
Supersedes Form No. S22-936 Rev. 4

## Featuring Industry Standard R-410A Refrigerant

### R-410A

### RLNL-B HIGH EFFICIENCY SERIES NOMINAL SIZES 6-12.5 TONS [21.1-44.0 kW] ASHRAE 90.1-2010 COMPLIANT MODELS



*"Proper sizing and installation of equipment is critical to achieve optimal performance. Ask your Contractor for details or visit [www.energystar.gov](http://www.energystar.gov)."*



Unit Features & Benefits .....	3-7
Selection Procedure .....	8
Model Identification Options .....	9-10
General Data	
RLNL-B- Series .....	11-19
General Data Notes .....	20
Performance Data	
RLNL-B- Series .....	21-23
Airflow Performance	
RLNL-B- Series .....	24-28
Electrical Data	
RLNL-B- Series .....	29-32
Units with Heater Kits .....	33-38
Dimensional Data .....	39-42
Accessories .....	43-64
Mechanical Specifications .....	65-66
Typical Wiring .....	67-70
Limited Warranty .....	72

## *These quality features are included in the Ruud Package Air Conditioner Unit*



### **STANDARD FEATURES INCLUDE:**

- R-410A HFC refrigerant.
- Complete factory charged, wired and run tested.
- Scroll compressors with internal line break overload and high-pressure protection.
- Single stage compressor on B073 model.
- Two stage compressor on B090 – B151 models.
- Convertible airflow.
- TXV refrigerant metering system on each circuit (except on B073).
- High Pressure and Low Pressure/Loss of charge protection standard on all models.
- Solid Core liquid line filter drier on each circuit.
- Single slab, single pass designed evaporator and condenser coils facilitate easy cleaning for maintained high efficiencies.
- Cooling operation up to 125 degree F ambient.
- Foil faced insulation encapsulated throughout entire unit minimizes airborne fibers from the air stream.
- Hinged major access door with heavy-duty gasketing, 1/4 turn latches and door retainers.
- Slide Out Indoor fan assembly for added service convenience.
- Powder Paint Finish meets ASTM B117 steel coated on each side for maximum protection. G90 galvanized.
- One piece top cover and one piece base pan with drawn supply and return opening for superior water management.
- Forkable base rails for easy handling and lifting.
- Single point electrical connections.
- Internally sloped slide out condensate pan conforms to ASHRAE 62 standards.
- High performance belt drive motor with variable pitch pulleys and quick adjust belt system.
- Permanently lubricated evaporator, condenser and gas heat inducer motors.
- Condenser motors are internally protected, totally enclosed with shaft down design.
- 2 inch filter standard with slide out design.
- 24 volt control system with resettable circuit breakers.
- Colored and labeled wiring.
- Copper tube/Aluminum Fin coils (12<sup>1</sup>/<sub>2</sub> uses micro channel condenser).
- Molded compressor plug.
- Supplemental electric heat provides 100% efficient heating.

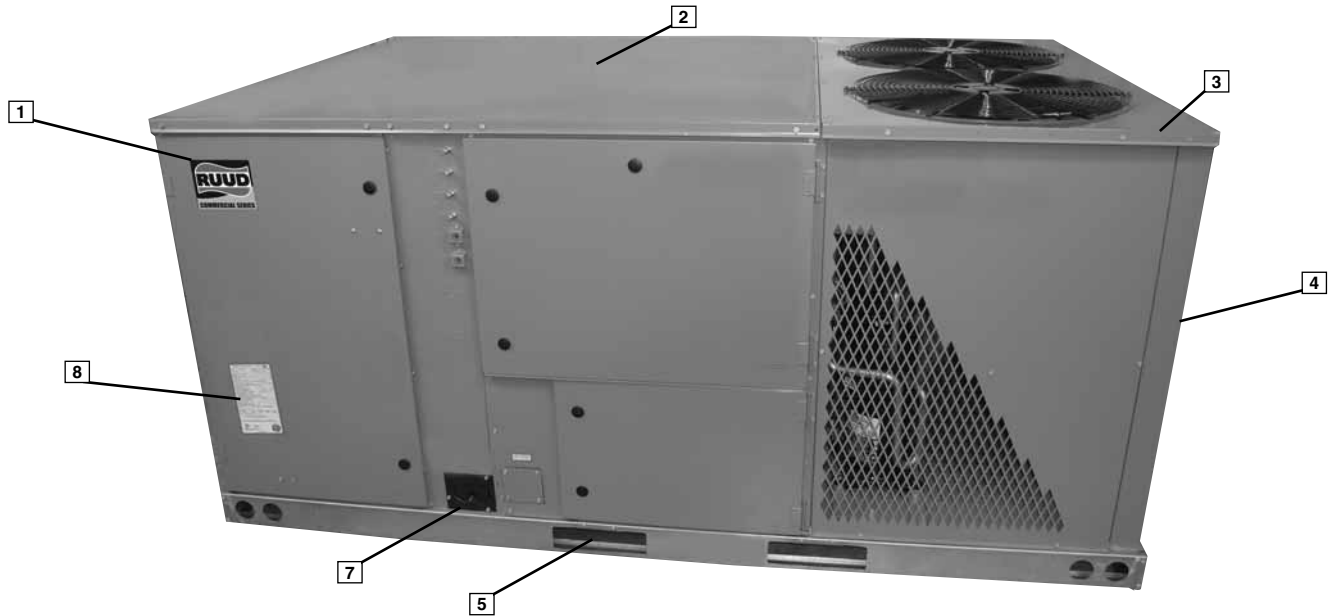

Ruud Package equipment is designed from the ground up with the latest features and benefits required to compete in today's market. The clean design stands alone in the industry and is a testament to the quality, reliability, ease of installation and serviceability that goes into each unit. Outwardly, the large Ruud Commercial Series™ label (1) identifies the brand to the customer. The sheet-metal cabinet (2) uses nothing less than 18-gauge material for structural components with an underlying coat of G90. To ensure the leak-proof integrity of these units, the design utilizes a one-piece top with a 1/8" drip lip (3), gasket-protected panels and screws. The Ruud hail guard (optional) (4) is its trademark, and sets the standard for coil protection in the industry. Every Ruud package unit uses the toughest finish in the industry, using electro deposition baked-on enamel tested to withstand a rigorous 1000-hour salt spray test, per ASTM B117.

Anything built to last must start with the right foundation. In this case, the foundation is 14-gauge, commercial-grade, full-perimeter base rails (5), which integrate fork slots and rigging holes to save set-up time on the job site. The base pan is stamped, which forms a 1-1/8" flange around the supply and return cover and has eliminated the worry of water entering the conditioned space (6). The insulation has been placed on the underside of the basepan, removing areas that would allow for potential moisture accumulation, which can facilitate growth of harmful bacteria. All insulation is secured with both adhesive and mechanical fasteners, and all edges are hidden. The drainpan (7) is made of material that resists the growth of harmful bacteria and is sloped for the latest IAQ benefits. Furthermore, the drain pan slides out for easy cleaning.

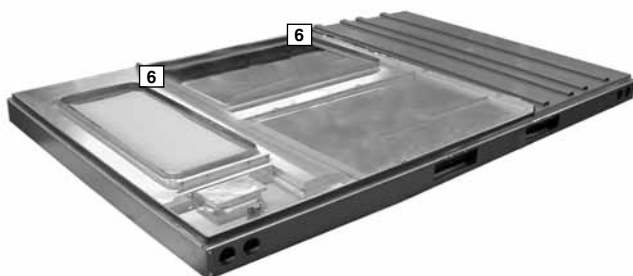

During development, each unit was tested to U.L. 1995, AHRI 340-370 and other Ruud-required reliability tests. Ruud adheres to stringent ISO 9002 quality procedures, and each unit bears the U.L. and AHRI certification labels located on the unit nameplate (8). Contractors can rest assured that when a Ruud package unit arrives at the job, it is ready to go with a factory charge and quality checks. Each unit also proudly displays the "Made in the USA" designation.

Access to all major compartments is from the front of the unit, including the filter and electrical compartment, blower compartment, heating section, and outdoor section. Each compartment has 1/4 turn fasteners and hinged access. Each panel is permanently embossed with the compartment name (control/filter access, blower access and electric heat access).

Electrical and filter compartment access is through a large, hinged-access panel. On the outside of the panel is the unit nameplate, which contains the model and serial number, electrical data and other important unit information.

The unit charging chart is located on the inside of the electrical and filter compartment door. Electrical wiring diagrams are found on the control box cover, which allows contractors to move them to more readable locations. To the right of the control box the model and serial number can be found. Having this information on the inside will assure model identification for the life of the product. The production line quality test assurance label is also placed in this location (9). The two-inch throwaway filters (10) are easily removed on a tracked system for easy replacement.



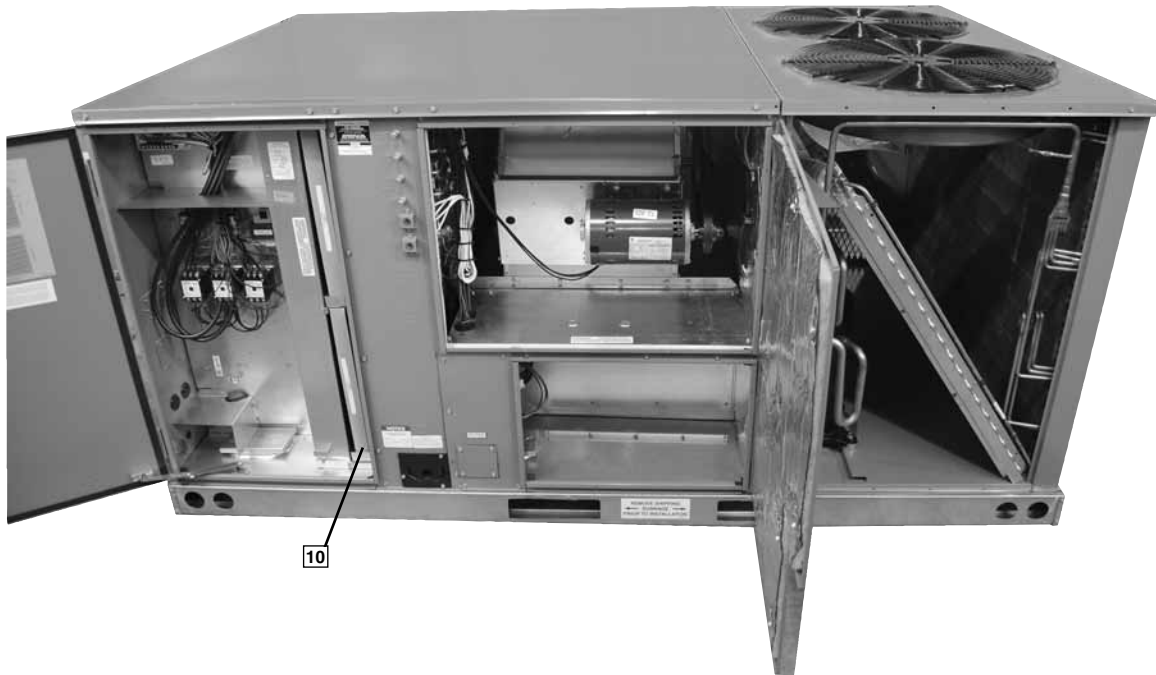

Inside the control box (11), each electrical component is clearly identified with a label that matches the component to the wire diagram for ease of trouble shooting. All wiring is numbered on each end of the termination and color-coded to match the wiring diagram. The control transformer has a low voltage circuit breaker that trips if a low voltage electrical short occurs. There is a blower contactor and compressor for each compressor.



For added convenience in the field, a factory-installed convenience outlet (12) is available. Low and High voltage can enter either from the side or through the base. Low-voltage connections are made integrated cooling control. The high-voltage connection is terminated at the number 1 compressor contactor. The suggested mounting for the field-installed disconnect is on the exterior side of the electrical control box.



To the right of the electrical and filter compartment are the externally mounted gauge ports, which are permanently identified by embossed wording that clearly identifies the compressor circuit, high pressure connection and low pressure connection (13). With the gauge ports mounted externally, an accurate diagnostic of system operation can be performed quickly and easily. The blower compartment is to the right of the gauge ports and can be accessed by 1/4 turn fasteners. To allow easy maintenance of the



blower assembly, the entire assembly easily slides out by removing the 3/8" screws from the blower retention bracket. The adjustable motor pulley (14) can easily be adjusted by loosening the bolts on either side of the motor mount. Removing the bolts allows for easy removal of the blower pulley by pushing the blower assembly up to loosen the belt. Once the pulley is removed, the motor sheave can be adjusted to the desired number of turns, ranging from 0 to 6 turns open. Where the demands for the job require high static, Ruud has high-static drives available that deliver nominal airflow up to 2" of static. By referring to the airflow performance tables listed in the installation instructions, proper static pressure and CFM requirements can be dialed in. The scroll housing (15) and blower scroll provide quiet and efficient airflow. The blower sheave is secured by an "H" bushing which firmly secures the pulley to the blower shaft for years of trouble-free operation. The "H" bushing allows for easy removal of the blower pulley from the shaft, as opposed to the use of a set screw, which can score the shaft, creating burrs that make blower-pulley removal difficult.

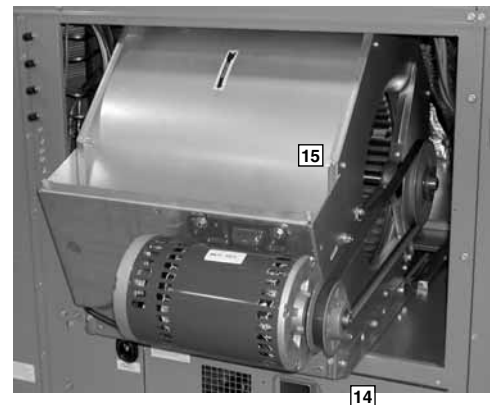

Also inside the blower compartment is the low-ambient control (16), low-pressure switch (17), high-pressure switch (18) and freeze stat refrigerant safety device (19) (optional). The low-ambient control allows for operation of the compressor down to 0 degrees ambient temperature by cycling the outdoor fans on high pressure. The high-pressure switch will shut off the compressors if pressures exceeds, 610 PSIG are detected, this may occur if the outdoor fan motor fails. The low-pressure switch shuts off the compressors if low pressure is detected due to loss of charge. The freeze stat protects the compressor if the evaporator coil gets too cold (below freezing) due to low airflow. Each factory-installed option is brazed into the appropriate high or low side and wired appropriately. Use of polarized plugs and sharder fittings allow for easy field installation.

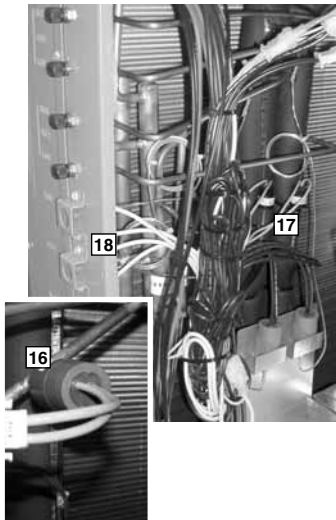

Inside the blower compartment the interlaced evaporator can also be viewed. The evaporator uses enhanced fin technology for maximum heat transfer. The TXV metering device assures even distribution of refrigerant throughout the evaporator. (Note: 6 ton single stage has an orifice refrigerant control.)

Wiring throughout the unit is neatly bundled and routed. Where wire harnesses go through the condenser bulkhead or blower deck, a molded wire harness assembly (20) provides an air-tight and water-tight seal, and provides strain relief. Care is also taken to tuck raw edges of insulation behind sheet metal to improve indoor air quality.

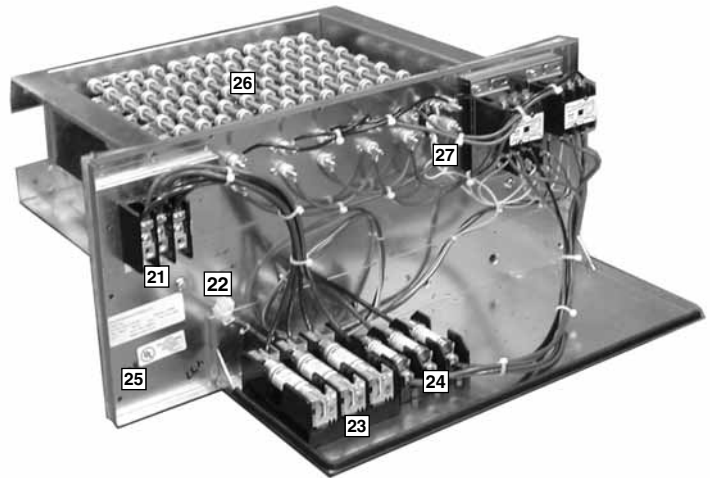
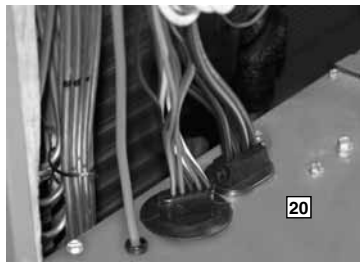

The heating compartment contains the latest electric furnace technology on the market. The 100% efficient electric furnace can be factory-installed or easily field-installed. Built with ease-of-installation in mind, the electric furnace is completely wired for slide-in, plug-and-play installation in the field. With choices of up to six kilowatt offerings, the contractor is assured to get the correct amount of heating output to meet the designed heating load.

Power hook-up in the field is easy with single-point wiring to a terminal block (21) and a polarized plug for the low-voltage connection (22). The electric furnace comes with fuses for the unit (23) and for the electric furnace (24), and is UL certified (25). The electric heating elements are of a wound-wire construction (26) and isolated with ceramic bushings. The limit switch (27) protects the design from over-temperature conditions. Each electric furnace has the capability to be converted from single-stage operation to two-stage operation by removing a jumper on the low-voltage terminal strip.

The compressor compartment houses the heart-beat of the unit. The scroll compressor (29) is known for its long life, and for reliable, quiet, and efficient operation. Each compressor has molded compressor plug eliminating potential for mis wiring. The suction and discharge lines are designed with shock loops (30) to absorb the strain and stress that the starting torque, steady state operation, and shut down cycle impose on the refrigerant tubing. Each compressor and circuit is independent for built-in redundancy, and each circuit is clearly marked throughout the system. Each unit has two stages of efficient cooling operation, first stage is approximately 50% of second stage (073 single stage).

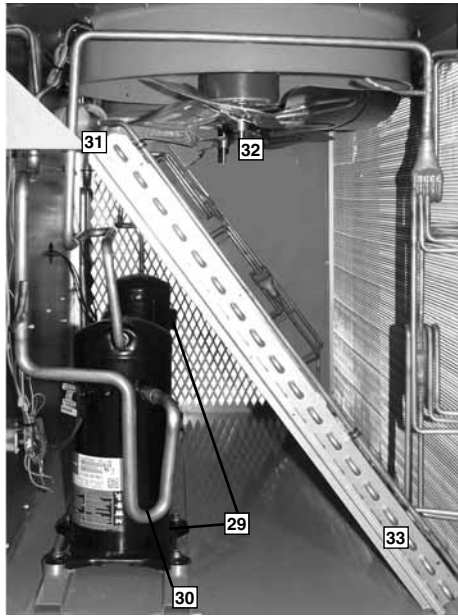

Each unit comes standard with filter dryer (31). The condenser fan motor (32) can easily be accessed and maintained through the compressor compartment. The polarized plug connection allows the motor to be changed quickly and eliminates the need to snake wires through the unit.

The outdoor coil uses the latest enhanced fin design (33) for the most effective method of heat transfer. The outdoor coil is protected by optional louvered panels, which allow unobstructed airflow while protecting the unit from both Mother Nature and vandalism.

Each unit is designed for both downflow or horizontal applications (34) for job configuration flexibility. The return air compartment can also contain an economizer (35).

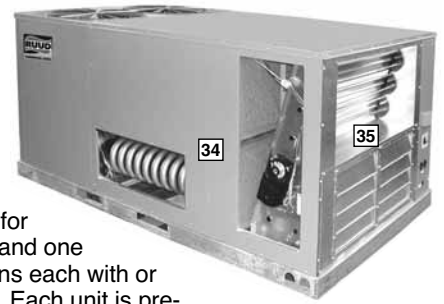

Four models exist, one for downflow applications, and one for horizontal applications each with or without smoke detector. Each unit is pre-wired for the economizer to allow quick plug-in installation. The economizer is also available as a factory-installed option. Power Exhaust is easily field-installed. The economizer, which provides free cooling when outdoor conditions are suitable and also provides fresh air to meet local requirements, comes standard with single enthalpy controls. The controls can be upgraded to dual enthalpy easily in the field. The direct drive actuator combined with gear drive dampers has eliminated the need for linkage adjustment in the field. The economizer control has a minimum position setpoint, an outdoor-air setpoint, a mix-air setpoint, and a CO<sup>2</sup> setpoint. Barometric relief is standard on all economizers. The power exhaust is housed in the barometric relief opening and is easily slipped in with a plug-in assembly. The wire harness to the economizer also has accommodations for a smoke detector.

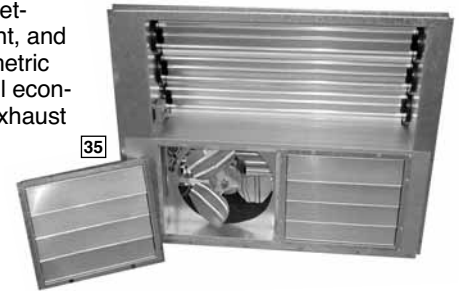

The Ruud roofcurb (36) is made for toolless assembly at the jobsite by engaging a pin into the hinged corner brackets into the adjacent curb sides, which makes the assembly process quick and easy.





To select an RLNL-B Cooling and Heating unit to meet a job requirement, follow this procedure, with example, using data supplied in this specification sheet.

## 1. DETERMINE COOLING AND HEATING REQUIREMENTS AND SPECIFIC OPERATING CONDITIONS FROM PLANS AND SPECS.

### Example:

Voltage—	230 V – 3 Phase – 60 Hz
Total Cooling Capacity—	106,000 BTUH [31.0 kW]
Sensible Cooling Capacity—	82,000 BTUH [24.0 kW]
Heating Capacity—	150,000 BTUH [43.9 kW]
*Condenser Entering Air—	95°F [35.0°C] DB
*Evaporator Mixed Air Entering—	65°F [18.3°C] WB 78°F [25.6°C] DB
*Indoor Air Flow (vertical)—	3600 CFM [1699 L/s]
*External Static Pressure—	0.40 in. WG [.10 kPa]

## 2. SELECT UNIT TO MEET COOLING REQUIREMENTS.

Since total cooling is within the range of a nominal 10 ton [35.1 kW] unit, enter cooling performance table at 95°F [35.0°C] DB condenser inlet air. Interpolate between 63°F [17.2°C] WB and 67°F [19.4°C] to determine total and sensible capacity and power input for 65°F [18.3°C] WB evaporator inlet air at 3750 CFM [1770 L/s] indoor air flow (table basis):

Total Cooling Capacity = 118,900 BTUH [34.82 kW]  
Sensible Cooling Capacity = 99,950 BTUH [29.27 kW]  
Power Input (Compressor and Cond. Fans) = 8,950 watts

Use formula in note ① to determine sensible capacity at 78°F [25.6°C] DB evaporator entering air:

$99,950 + (1.10 \times 3,600 \times (1 - 0.03) \times (78 - 80))$   
Sensible Cooling Capacity = 92,268 BTUH [27.02 kW]

## 3. CORRECT CAPACITIES OF STEP 2 FOR ACTUAL AIR FLOW.

Select factors from airflow correction table at 3600 CFM [1699 L/s] and apply to data obtained in step 2 to obtain gross capacity:

Total Capacity =  $118,900 \times 0.98 = 116,522$  BTUH [34.12 kW]  
Sensible Capacity =  $92,268 \times 0.95 = 87,655$  BTUH [25.67 kW]  
Power Input =  $8,950 \times 0.99 = 8,861$  Watts

These are Gross Capacities, not corrected for blower motor heat or power.

## 4. DETERMINE BLOWER SPEED AND WATTS TO MEET SYSTEM DESIGN.

Enter Indoor Blower performance table at 3600 CFM [1699 L/s]. Total ESP (external static pressure) per the spec of 0.40 in. WG [.10 kPa] includes the system duct and grilles. Add from the table “Component Air Resistance,” 0.076 in. WG [.02 kPa] for wet coil, 0 in. WG [.00 kPa] for downflow air flow for a total selection static pressure of 0.476 (0.5) in. WG [.12 kPa], and determine:

RPM = 769  
WATTS = 1,576  
DRIVE = L (standard 2 H.P. motor)

## 5. CALCULATE INDOOR BLOWER BTUH HEAT EFFECT FROM MOTOR WATTS, STEP 4.

$$1,576 \times 3.412 = 5,377 \text{ BTUH [1.57 kW]}$$

## 6. CALCULATE NET COOLING CAPACITIES, EQUAL TO GROSS CAPACITY, STEP 3, MINUS INDOOR BLOWER MOTOR HEAT.

$$\text{Net Total Capacity} = 116,522 - 5,377 = 111,145 \text{ BTUH [32.54 kW]}$$

$$\text{Net Sensible Capacity} = 87,655 - 5,377 = 82,278 \text{ BTUH [24.09 kW]}$$

## 7. CALCULATE UNIT INPUT AND JOB EER.

$$\text{Total Power Input} = 8,861 \text{ (step 3)} + 1,576 \text{ (step 4)} = 10,437 \text{ Watts}$$

$$\text{EER} = \frac{\text{Net Total BTUH [kW]} \text{ (step 6)}}{\text{Power Input, Watts (above)}} = \frac{111,145}{10,437} = 10.65$$

## 8. SELECT UNIT HEATING CAPACITY.

From Heater Kit Table select kW to meet heating capacity requirement; multiply kW x 3412 to convert to BTUH.

Use 50 kW Heater Kit

Heater Kit Model: RXU-CC50C      Heater Kit Capacity: 163,776 BTUH [48.0 kW]

Add indoor blower heat effect (step 5) to Heater Kit Capacity to get total heating capacity:

$$163,776 + 5,377 = 169,153 \text{ BTUH [49.5 kW]}$$

## 9. CHOOSE MODEL RLNL-B120CL050.

\*NOTE: These operating conditions are typical of a commercial application in a 95°F/79°F [35°C/26°C] design area with indoor design of 76°F [24°C] DB and 50% RH and 10% ventilation air, with the unit roof mounted and centered on the zone it conditions by ducts.

[ ] Designates Metric Conversions

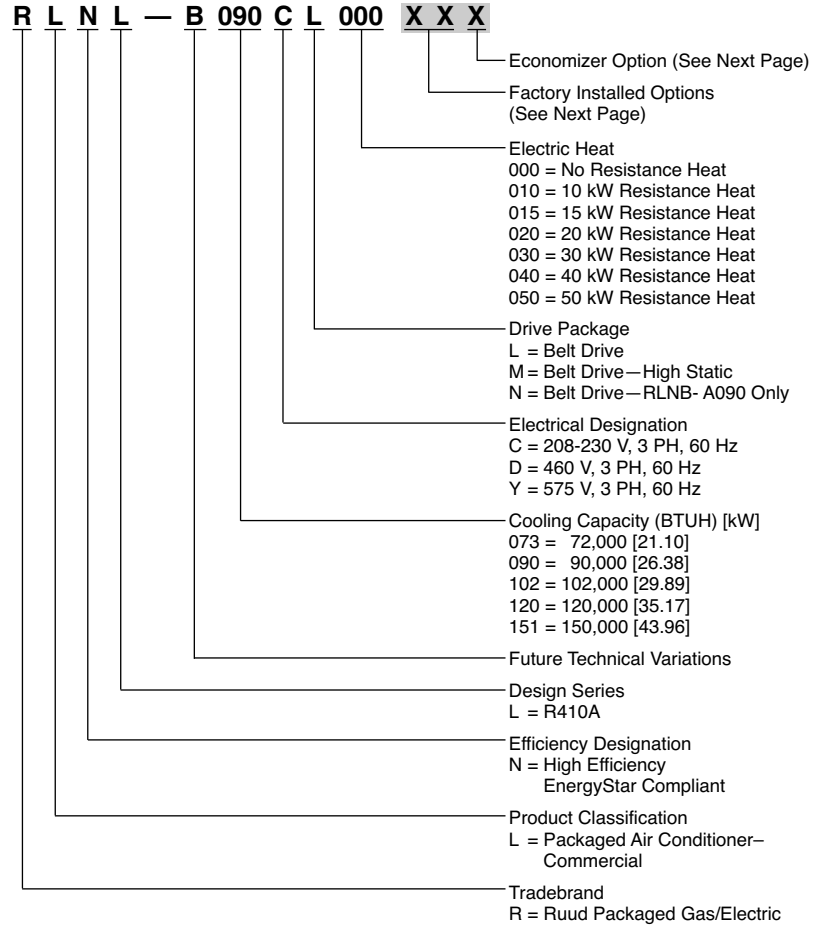

[ ] Designates Metric Conversions



## 6 TO 12.5 TON [21.1 TO 44.0 kW]

Option Code	Hail Guard	Non-Powered Convenience Outlet	Low Ambient/ Freeze Stat
AD	x		
AG		x	
AP			x
BY	x		x
BJ	x	x	
CX	x	x	x
JC		x	x

“x” indicates factory installed option.

## ECONOMIZER SELECTION FOR LNL 6 TO 12.5 TON [21.1 TO 44.0 kW]

	No Economizer	Single Enthalpy Economizer with Barometric Relief	Single Enthalpy Economizer with Barometric Relief and Smoke Detector
A	x		
F		x	
G			x

“x” indicates factory installed option.

## Instructions for Factory Installed Option(s) Selection

**Note:** Three characters following the model number will be utilized to designate a factory-installed option or combination of options. If no factory option(s) is required, nothing follows the model number.

**Step 1.** After a basic rooftop model is selected, choose a *two-character* option code from the FACTORY INSTALLED OPTION SELECTION TABLE.

Proceed to Step 2.

**Step 2.** The last option code character is utilized for factory-installed economizers. Choose a character from the FACTORY INSTALLED ECONOMIZER SELECTION TABLE.

## Examples:

RLNL-B120CL000 .....this unit has no factory installed options.

RLNL-B120CL000**ADA** .....this unit is equipped with *hail guards*.

RLNL-B120CL000**BYA** .....this unit is equipped with *hail guards, low ambient and unit freeze stat*.

RLNL-B120CL000**BYF** .....this unit is equipped as above *and* includes an *Economizer with single enthalpy sensor and with barometric relief*.

RLNL-B120CL000**AAG** .....this unit is equipped with an *Economizer with single enthalpy sensor and barometric relief with smoke detector*.

[ ] Designates Metric Conversions



**NOM. SIZES 6-12.5 TONS [21.1-44.0 kW] ASHRAE 90.1-2010 COMPLIANT MODELS**

Model RLNL- Series	B073CL	B073CM	B073DL	B073DM
<b>Cooling Performance<sup>1</sup></b>				<b>CONTINUED →</b>
Gross Cooling Capacity Btu [kW]	75,000 [21.97]	75,000 [21.97]	75,000 [21.97]	75,000 [21.97]
EER/SEER <sup>2</sup>	11.2/NA	11.2/NA	11.2/NA	11.2/NA
Nominal CFM/AHRI Rated CFM [L/s]	2400/2325 [1133/1097]	2400/2325 [1133/1097]	2400/2325 [1133/1097]	2400/2325 [1133/1097]
AHRI Net Cooling Capacity Btu [kW]	72,000 [21.1]	72,000 [21.1]	72,000 [21.1]	72,000 [21.1]
Net Sensible Capacity Btu [kW]	52,800 [15.47]	52,800 [15.47]	52,800 [15.47]	52,800 [15.47]
Net Latent Capacity Btu [kW]	19,200 [5.63]	19,200 [5.63]	19,200 [5.63]	19,200 [5.63]
IEER <sup>3</sup>	11.8	11.8	11.8	11.8
Net System Power [kW]	6.42	6.42	6.42	6.42
<b>Compressor</b>				
No./Type	1/Scroll	1/Scroll	1/Scroll	1/Scroll
<b>Outdoor Sound Rating (dB)<sup>4</sup></b>				
	88	88	88	88
<b>Outdoor Coil—Fin Type</b>				
Tube Type	Louvered	Louvered	Louvered	Louvered
Tube Size in. [mm] OD	Rifled	Rifled	Rifled	Rifled
Tube Size in. [mm] OD	0.375 [9.5]	0.375 [9.5]	0.375 [9.5]	0.375 [9.5]
Face Area sq. ft. [sq. m]	13.5 [1.25]	13.5 [1.25]	13.5 [1.25]	13.5 [1.25]
Rows / FPI [FPcm]	1 / 22 [9]	1 / 22 [9]	1 / 22 [9]	1 / 22 [9]
<b>Indoor Coil—Fin Type</b>				
Tube Type	Louvered	Louvered	Louvered	Louvered
Tube Type	Rifled	Rifled	Rifled	Rifled
Tube Size in. [mm]	0.375 [9.5]	0.375 [9.5]	0.375 [9.5]	0.375 [9.5]
Face Area sq. ft. [sq. m]	13.5 [1.25]	13.5 [1.25]	13.5 [1.25]	13.5 [1.25]
Rows / FPI [FPcm]	2 / 18 [7]	2 / 18 [7]	2 / 18 [7]	2 / 18 [7]
Refrigerant Control	TX Valves	TX Valves	TX Valves	TX Valves
Drain Connection No./Size in. [mm]	1/1 [25.4]	1/1 [25.4]	1/1 [25.4]	1/1 [25.4]
<b>Outdoor Fan—Type</b>				
	Propeller	Propeller	Propeller	Propeller
No. Used/Diameter in. [mm]	2/24 [609.6]	2/24 [609.6]	2/24 [609.6]	2/24 [609.6]
Drive Type/No. Speeds	Direct/1	Direct/1	Direct/1	Direct/1
CFM [L/s]	8000 [3775]	8000 [3775]	8000 [3775]	8000 [3775]
No. Motors/HP	2 at 1/3 HP	2 at 1/3 HP	2 at 1/3 HP	2 at 1/3 HP
Motor RPM	1075	1075	1075	1075
<b>Indoor Fan—Type</b>				
	FC Centrifugal	FC Centrifugal	FC Centrifugal	FC Centrifugal
No. Used/Diameter in. [mm]	1/11x12 [279x305]	1/11x12 [279x305]	1/11x12 [279x305]	1/11x12 [279x305]
Drive Type/No. Speeds	Belt/Variable	Belt/Variable	Belt/Variable	Belt/Variable
No. Motors	1	1	1	1
Motor HP	1 1/2	1 1/2	1 1/2	1 1/2
Motor RPM	1725	1725	1725	1725
Motor Frame Size	56	56	56	56
<b>Filter—Type</b>				
	Disposable	Disposable	Disposable	Disposable
Furnished	Yes	Yes	Yes	Yes
(NO.) Size Recommended in. [mm x mm x mm]	(6)2x18x18 [51x457x457]	(6)2x18x18 [51x457x457]	(6)2x18x18 [51x457x457]	(6)2x18x18 [51x457x457]
<b>Refrigerant Charge Oz. [g]</b>				
	125 [3544]	125 [3544]	125 [3544]	125 [3544]
<b>Weights</b>				
Net Weight lbs. [kg]	901 [409]	901 [409]	901 [409]	901 [409]
Ship Weight lbs. [kg]	938 [425]	938 [425]	938 [425]	938 [425]

See Page 20 for Notes.

[ ] Designates Metric Conversions



## NOM. SIZES 6-12.5 TONS [21.1-44.0 kW] ASHRAE 90.1-2010 COMPLIANT MODELS

Model RLNL- Series	B073YL	B073YM	B090CL	B090CM
<b>Cooling Performance<sup>1</sup></b>				
Gross Cooling Capacity Btu [kW]	75,000 [21.97]	75,000 [21.97]	93,000 [27.25]	93,000 [27.25]
EER/SEER <sup>2</sup>	11.2/NA	11.2/NA	11.2/NA	11.2/NA
Nominal CFM/AHRI Rated CFM [L/s]	2400/2325 [1133/1097]	2400/2325 [1133/1097]	3000/2775 [1416/1310]	3000/2775 [1416/1310]
AHRI Net Cooling Capacity Btu [kW]	72,000 [21.1]	72,000 [21.1]	90,000 [26.37]	90,000 [26.37]
Net Sensible Capacity Btu [kW]	52,800 [15.47]	52,800 [15.47]	63,100 [18.49]	63,100 [18.49]
Net Latent Capacity Btu [kW]	19,200 [5.63]	19,200 [5.63]	26,900 [7.88]	26,900 [7.88]
IEER <sup>3</sup>	11.8	11.8	11.9	11.9
Net System Power [kW]	6.42	6.42	7.99	7.99
<b>Compressor</b>				
No./Type	1/Scroll	1/Scroll	2/Scroll	2/Scroll
<b>Outdoor Sound Rating (dB)<sup>4</sup></b>				
	88	88	88	88
<b>Outdoor Coil—Fin Type</b>				
Tube Type	Louvered	Louvered	Louvered	Louvered
Tube Size in. [mm] OD	Rifled	Rifled	Rifled	Rifled
Face Area sq. ft. [sq. m]	0.375 [9.5]	0.375 [9.5]	0.375 [9.5]	0.375 [9.5]
Rows / FPI [FPcm]	13.5 [1.25]	13.5 [1.25]	27 [2.51]	27 [2.51]
Rows / FPI [FPcm]	1 / 22 [9]	1 / 22 [9]	1 / 22 [9]	1 / 22 [9]
<b>Indoor Coil—Fin Type</b>				
Tube Type	Louvered	Louvered	Louvered	Louvered
Tube Type	Rifled	Rifled	Rifled	Rifled
Tube Size in. [mm]	0.375 [9.5]	0.375 [9.5]	0.375 [9.5]	0.375 [9.5]
Face Area sq. ft. [sq. m]	13.5 [1.25]	13.5 [1.25]	13.5 [1.25]	13.5 [1.25]
Rows / FPI [FPcm]	2 / 18 [7]	2 / 18 [7]	2 / 18 [7]	2 / 18 [7]
Refrigerant Control	TX Valves	TX Valves	TX Valves	TX Valves
Drain Connection No./Size in. [mm]	1/1 [25.4]	1/1 [25.4]	1/1 [25.4]	1/1 [25.4]
<b>Outdoor Fan—Type</b>				
Type	Propeller	Propeller	Propeller	Propeller
No. Used/Diameter in. [mm]	2/24 [609.6]	2/24 [609.6]	2/24 [609.6]	2/24 [609.6]
Drive Type/No. Speeds	Direct/1	Direct/1	Direct/1	Direct/1
CFM [L/s]	8000 [3775]	8000 [3775]	8000 [3775]	8000 [3775]
No. Motors/HP	2 at 1/3 HP	2 at 1/3 HP	2 at 1/3 HP	2 at 1/3 HP
Motor RPM	1075	1075	1075	1075
<b>Indoor Fan—Type</b>				
Type	FC Centrifugal	FC Centrifugal	FC Centrifugal	FC Centrifugal
No. Used/Diameter in. [mm]	1/11x12 [279x305]	1/11x12 [279x305]	1/15x15 [381x381]	1/15x15 [381x381]
Drive Type/No. Speeds	Belt/Variable	Belt/Variable	Belt/Variable	Belt/Variable
No. Motors	1	1	1	1
Motor HP	1 1/2	1 1/2	2	2
Motor RPM	1725	1725	1725	1725
Motor Frame Size	56	56	56	56
<b>Filter—Type</b>				
Type	Disposable	Disposable	Disposable	Disposable
Furnished	Yes	Yes	Yes	Yes
(NO.) Size Recommended in. [mm x mm x mm]	(6)2x18x18 [51x457x457]	(6)2x18x18 [51x457x457]	(6)2x18x18 [51x457x457]	(6)2x18x18 [51x457x457]
<b>Refrigerant Charge Oz. [g]</b>				
	125 [3544]	125 [3544]	107.5/110.7 [3048/3138]	107.5/110.7 [3048/3138]
<b>Weights</b>				
Net Weight lbs. [kg]	901 [409]	901 [409]	1017 [461]	1017 [461]
Ship Weight lbs. [kg]	938 [425]	938 [425]	1054 [478]	1054 [478]

**CONTINUED** →

See Page 20 for Notes.

[ ] Designates Metric Conversions



**NOM. SIZES 6-12.5 TONS [21.1-44.0 kW] ASHRAE 90.1-2010 COMPLIANT MODELS**

Model RLNL- Series	B090CN	B090DL	B090DM	B090DN
<b>Cooling Performance<sup>1</sup></b>				<b>CONTINUED</b> →
Gross Cooling Capacity Btu [kW]	93,000 [27.25]	93,000 [27.25]	93,000 [27.25]	93,000 [27.25]
EER/SEER <sup>2</sup>	11.2/NA	11.2/NA	11.2/NA	11.2/NA
Nominal CFM/AHRI Rated CFM [L/s]	3000/2775 [1416/1310]	3000/2775 [1416/1310]	3000/2775 [1416/1310]	3000/2775 [1416/1310]
AHRI Net Cooling Capacity Btu [kW]	90,000 [26.37]	90,000 [26.37]	90,000 [26.37]	90,000 [26.37]
Net Sensible Capacity Btu [kW]	63,100 [18.49]	63,100 [18.49]	63,100 [18.49]	63,100 [18.49]
Net Latent Capacity Btu [kW]	26,900 [7.88]	26,900 [7.88]	26,900 [7.88]	26,900 [7.88]
IEER <sup>3</sup>	11.9	11.9	11.9	11.9
Net System Power kW	7.99	7.99	7.99	7.99
<b>Compressor</b>				
No./Type	2/Scroll	2/Scroll	2/Scroll	2/Scroll
<b>Outdoor Sound Rating (dB)<sup>4</sup></b>				
	88	88	88	88
<b>Outdoor Coil—Fin Type</b>				
Tube Type	Louvered	Louvered	Louvered	Louvered
Tube Size in. [mm] OD	Rifled	Rifled	Rifled	Rifled
Face Area sq. ft. [sq. m]	0.375 [9.5]	0.375 [9.5]	0.375 [9.5]	0.375 [9.5]
Rows / FPI [FPcm]	27 [2.51]	2.7 [0.25]	2.7 [0.25]	27 [2.51]
	1 / 22 [9]	1 / 22 [9]	1 / 22 [9]	1 / 22 [9]
<b>Indoor Coil—Fin Type</b>				
Tube Type	Louvered	Louvered	Louvered	Louvered
Tube Size in. [mm]	Rifled	Rifled	Rifled	Rifled
Face Area sq. ft. [sq. m]	0.375 [9.5]	0.375 [9.5]	0.375 [9.5]	0.375 [9.5]
Rows / FPI [FPcm]	13.5 [1.25]	13.5 [1.25]	13.5 [1.25]	13.5 [1.25]
	2 / 18 [7]	2 / 18 [7]	2 / 18 [7]	2 / 18 [7]
Refrigerant Control	TX Valves	TX Valves	TX Valves	TX Valves
Drain Connection No./Size in. [mm]	1/1 [25.4]	1/1 [25.4]	1/1 [25.4]	1/1 [25.4]
<b>Outdoor Fan—Type</b>				
	Propeller	Propeller	Propeller	Propeller
No. Used/Diameter in. [mm]	2/24 [609.6]	2/24 [609.6]	2/24 [609.6]	2/24 [609.6]
Drive Type/No. Speeds	Direct/1	Direct/1	Direct/1	Direct/1
CFM [L/s]	8000 [3775]	8000 [3775]	8000 [3775]	8000 [3775]
No. Motors/HP	2 at 1/3 HP	2 at 1/3 HP	2 at 1/3 HP	2 at 1/3 HP
Motor RPM	1075	1075	1075	1075
<b>Indoor Fan—Type</b>				
	FC Centrifugal	FC Centrifugal	FC Centrifugal	FC Centrifugal
No. Used/Diameter in. [mm]	1/15x15 [381x381]	1/15x15 [381x381]	1/15x15 [381x381]	1/15x15 [381x381]
Drive Type/No. Speeds	Belt/Variable	Belt/Variable	Belt/Variable	Belt/Variable
No. Motors	1	1	1	1
Motor HP	3	2	2	3
Motor RPM	1725	1725	1725	1725
Motor Frame Size	56	56	56	56
<b>Filter—Type</b>				
	Disposable	Disposable	Disposable	Disposable
Furnished	Yes	Yes	Yes	Yes
(No.) Size Recommended in. [mm]	(6)2x18x18 [51x457x457]	(6)2x18x18 [51x457x457]	(6)2x18x18 [51x457x457]	(6)2x18x18 [51x457x457]
<b>Refrigerant Charge Oz. (Sys. 1/Sys. 2) [g]</b>				
	107.5/110.7 [3048/3138]	107.5/110.7 [3048/3138]	107.5/110.7 [3048/3138]	107.5/110.7 [3048/3138]
<b>Weights</b>				
Net Weight lbs. [kg]	1025 [465]	1017 [461]	1017 [461]	1025 [465]
Ship Weight lbs. [kg]	1062 [482]	1054 [478]	1054 [478]	1062 [482]

See Page 20 for Notes.

[ ] Designates Metric Conversions



## NOM. SIZES 6-12.5 TONS [21.1-44.0 kW] ASHRAE 90.1-2010 COMPLIANT MODELS

Model RLNL- Series	B090YL	B090YM	B090YN	B102CL
<b>Cooling Performance<sup>1</sup></b>				<b>CONTINUED</b> →
Gross Cooling Capacity Btu [kW]	93,000 [27.25]	93,000 [27.25]	93,000 [27.25]	101,000 [29.59]
EER/SEER <sup>2</sup>	11.2/NA	11.2/NA	11.2/NA	11.2/NA
Nominal CFM/AHRI Rated CFM [L/s]	3000/2775 [1416/1310]	3000/2775 [1416/1310]	3000/2775 [1416/1310]	3200/3200 [1510/1510]
AHRI Net Cooling Capacity Btu [kW]	90,000 [26.37]	90,000 [26.37]	90,000 [26.37]	97,000 [28.42]
Net Sensible Capacity Btu [kW]	63,100 [18.49]	63,100 [18.49]	63,100 [18.49]	74,000 [21.68]
Net Latent Capacity Btu [kW]	26,900 [7.88]	26,900 [7.88]	26,900 [7.88]	23,000 [6.74]
IEER <sup>3</sup>	11.9	11.9	11.9	12
Net System Power kW	7.99	7.99	7.99	8.59
<b>Compressor</b>				
No./Type	2/Scroll	2/Scroll	2/Scroll	2/Scroll
<b>Outdoor Sound Rating (dB)<sup>4</sup></b>				
	88	88	88	88
<b>Outdoor Coil—Fin Type</b>				
Tube Type	Louvered	Louvered	Louvered	Louvered
Tube Type	Rifled	Rifled	Rifled	Rifled
Tube Size in. [mm] OD	0.375 [9.5]	0.375 [9.5]	0.375 [9.5]	0.375 [9.5]
Face Area sq. ft. [sq. m]	27 [2.51]	27 [2.51]	27 [2.51]	27 [2.51]
Rows / FPI [FPcm]	1 / 22 [9]	1 / 22 [9]	1 / 22 [9]	2 / 18 [7]
<b>Indoor Coil—Fin Type</b>				
Tube Type	Louvered	Louvered	Louvered	Louvered
Tube Type	Rifled	Rifled	Rifled	Rifled
Tube Size in. [mm]	0.375 [9.5]	0.375 [9.5]	0.375 [9.5]	0.375 [9.5]
Face Area sq. ft. [sq. m]	13.5 [1.25]	13.5 [1.25]	13.5 [1.25]	13.5 [1.25]
Rows / FPI [FPcm]	2 / 18 [7]	2 / 18 [7]	2 / 18 [7]	2 / 18 [7]
Refrigerant Control	TX Valves	TX Valves	TX Valves	TX Valves
Drain Connection No./Size in. [mm]	1/1 [25.4]	1/1 [25.4]	1/1 [25.4]	1/1 [25.4]
<b>Outdoor Fan—Type</b>				
Propeller	Propeller	Propeller	Propeller	Propeller
No. Used/Diameter in. [mm]	2/24 [609.6]	2/24 [609.6]	2/24 [609.6]	2/24 [609.6]
Drive Type/No. Speeds	Direct/1	Direct/1	Direct/1	Direct/1
CFM [L/s]	8000 [3775]	8000 [3775]	8000 [3775]	8000 [3775]
No. Motors/HP	2 at 1/3 HP	2 at 1/3 HP	2 at 1/3 HP	2 at 1/3 HP
Motor RPM	1075	1075	1075	1075
<b>Indoor Fan—Type</b>				
FC Centrifugal	FC Centrifugal	FC Centrifugal	FC Centrifugal	FC Centrifugal
No. Used/Diameter in. [mm]	1/15x15 [381x381]	1/15x15 [381x381]	1/15x15 [381x381]	1/15x15 [381x381]
Drive Type/No. Speeds	Belt/Variable	Belt/Variable	Belt/Variable	Belt/Variable
No. Motors	1	1	1	1
Motor HP	2	2	3	2
Motor RPM	1725	1725	1725	1725
Motor Frame Size	56	56	56	56
<b>Filter—Type</b>				
Disposable	Disposable	Disposable	Disposable	Disposable
Furnished	Yes	Yes	Yes	Yes
(No.) Size Recommended in. [mm]	(6)2x18x18 [51x457x457]	(6)2x18x18 [51x457x457]	(6)2x18x18 [51x457x457]	(6)2x18x18 [51x457x457]
<b>Refrigerant Charge Oz. (Sys. 1/Sys. 2) [g]</b>				
	107.5/110.7 [3048/3138]	107.5/110.7 [3048/3138]	107.5/110.7 [3048/3138]	154.4/166.6 [4377/4723]
<b>Weights</b>				
Net Weight lbs. [kg]	1017 [461]	1017 [461]	1025 [465]	1059 [480]
Ship Weight lbs. [kg]	1054 [478]	1054 [478]	1062 [482]	1096 [497]

See Page 20 for Notes.

[ ] Designates Metric Conversions



**NOM. SIZES 6-12.5 TONS [21.1-44.0 kW] ASHRAE 90.1-2010 COMPLIANT MODELS**

Model RLNL- Series	B102CM	B102DL	B102DM	B102YL
<b>Cooling Performance<sup>1</sup></b>				<b>CONTINUED →</b>
Gross Cooling Capacity Btu [kW]	101,000 [29.59]	101,000 [29.59]	101,000 [29.59]	101,000 [29.59]
EER/SEER <sup>2</sup>	11.2/NA	11.2/NA	11.2/NA	11.2/NA
Nominal CFM/AHRI Rated CFM [L/s]	3200/3200 [1510/1510]	3200/3200 [1510/1510]	3200/3200 [1510/1510]	3200/3200 [1510/1510]
AHRI Net Cooling Capacity Btu [kW]	97,000 [28.42]	97,000 [28.42]	97,000 [28.42]	97,000 [28.42]
Net Sensible Capacity Btu [kW]	74,000 [21.68]	74,000 [21.68]	74,000 [21.68]	74,000 [21.68]
Net Latent Capacity Btu [kW]	23,000 [6.74]	23,000 [6.74]	23,000 [6.74]	23,000 [6.74]
IEER <sup>3</sup>	12	12	12	12
Net System Power kW	8.59	8.59	8.59	8.59
<b>Compressor</b>				
No./Type	2/Scroll	2/Scroll	2/Scroll	2/Scroll
<b>Outdoor Sound Rating (dB)<sup>4</sup></b>				
	88	88	88	88
<b>Outdoor Coil—Fin Type</b>				
Tube Type	Louvered	Louvered	Louvered	Louvered
Tube Size in. [mm] OD	Rifled	Rifled	Rifled	Rifled
Face Area sq. ft. [sq. m]	0.375 [9.5]	0.375 [9.5]	0.375 [9.5]	0.375 [9.5]
Rows / FPI [FPcm]	27 [2.51]	27 [2.51]	27 [2.51]	27 [2.51]
	2 / 18 [7]	2 / 18 [7]	2 / 18 [7]	2 / 18 [7]
<b>Indoor Coil—Fin Type</b>				
Tube Type	Louvered	Louvered	Louvered	Louvered
Tube Size in. [mm]	Rifled	Rifled	Rifled	Rifled
Face Area sq. ft. [sq. m]	0.375 [9.5]	0.375 [9.5]	0.375 [9.5]	0.375 [9.5]
Rows / FPI [FPcm]	13.5 [1.25]	13.5 [1.25]	13.5 [1.25]	13.5 [1.25]
	2 / 18 [7]	2 / 18 [7]	2 / 18 [7]	2 / 18 [7]
Refrigerant Control	TX Valves	TX Valves	TX Valves	TX Valves
Drain Connection No./Size in. [mm]	1/1 [25.4]	1/1 [25.4]	1/1 [25.4]	1/1 [25.4]
<b>Outdoor Fan—Type</b>				
No. Used/Diameter in. [mm]	Propeller	Propeller	Propeller	Propeller
Drive Type/No. Speeds	2/24 [609.6]	2/24 [609.6]	2/24 [609.6]	2/24 [609.6]
CFM [L/s]	Direct/1	Direct/1	Direct/1	Direct/1
No. Motors/HP	8000 [3775]	8000 [3775]	8000 [3775]	8000 [3775]
Motor RPM	2 at 1/3 HP	2 at 1/3 HP	2 at 1/3 HP	2 at 1/3 HP
	1075	1075	1075	1075
<b>Indoor Fan—Type</b>				
No. Used/Diameter in. [mm]	FC Centrifugal	FC Centrifugal	FC Centrifugal	FC Centrifugal
Drive Type/No. Speeds	1/15x15 [381x381]	1/15x15 [381x381]	1/15x15 [381x381]	1/15x15 [381x381]
No. Motors	Belt/Variable	Belt/Variable	Belt/Variable	Belt/Variable
Motor HP	1	1	1	1
Motor RPM	3	2	3	2
Motor Frame Size	1725	1725	1725	1725
	56	56	56	56
<b>Filter—Type</b>				
Furnished	Disposable	Disposable	Disposable	Disposable
(No.) Size Recommended in. [mm]	Yes	Yes	Yes	Yes
	(6)2x18x18 [51x457x457]	(6)2x18x18 [51x457x457]	(6)2x18x18 [51x457x457]	(6)2x18x18 [51x457x457]
<b>Refrigerant Charge Oz. (Sys. 1/Sys. 2) [g]</b>				
	154.4/166.6 [4377/4723]	154.4/166.6 [4377/4723]	154.4/166.6 [4377/4723]	154.4/166.6 [4377/4723]
<b>Weights</b>				
Net Weight lbs. [kg]	1067 [484]	1059 [480]	1067 [484]	1059 [480]
Ship Weight lbs. [kg]	1104 [501]	1096 [497]	1104 [501]	1096 [497]

See Page 20 for Notes.

[ ] Designates Metric Conversions



## NOM. SIZES 6-12.5 TONS [21.1-44.0 kW] ASHRAE 90.1-2010 COMPLIANT MODELS

Model RLNL- Series	B102YM	B120CL	B120CM	B120DL
<b>Cooling Performance<sup>1</sup></b>				<b>CONTINUED</b> →
Gross Cooling Capacity Btu [kW]	101,000 [29.59]	123,000 [36.04]	123,000 [36.04]	123,000 [36.04]
EER/SEER <sup>2</sup>	11.2/NA	11.2/NA	11.2/NA	11.2/NA
Nominal CFM/AHRI Rated CFM [L/s]	3200/3200 [1510/1510]	4000/3750 [1888/1770]	4000/3750 [1888/1770]	4000/3750 [1888/1770]
AHRI Net Cooling Capacity Btu [kW]	97,000 [28.42]	118,000 [34.57]	118,000 [34.57]	118,000 [34.57]
Net Sensible Capacity Btu [kW]	74,000 [21.68]	88,800 [26.02]	88,800 [26.02]	88,800 [26.02]
Net Latent Capacity Btu [kW]	23,000 [6.74]	29,200 [8.56]	29,200 [8.56]	29,200 [8.56]
IEER <sup>3</sup>	12	11.9	11.9	11.9
Net System Power kW	8.59	10.49	10.49	10.49
<b>Compressor</b>				
No./Type	2/Scroll	2/Scroll	2/Scroll	2/Scroll
<b>Outdoor Sound Rating (dB)<sup>4</sup></b>	88	88	88	88
<b>Outdoor Coil—Fin Type</b>	Louvered	Louvered	Louvered	Louvered
Tube Type	Rifled	Rifled	Rifled	Rifled
Tube Size in. [mm] OD	0.375 [9.5]	0.375 [9.5]	0.375 [9.5]	0.375 [9.5]
Face Area sq. ft. [sq. m]	27 [2.51]	27 [2.51]	27 [2.51]	27 [2.51]
Rows / FPI [FPcm]	2 / 18 [7]	2 / 22 [9]	2 / 22 [9]	2 / 22 [9]
<b>Indoor Coil—Fin Type</b>	Louvered	Louvered	Louvered	Louvered
Tube Type	Rifled	Rifled	Rifled	Rifled
Tube Size in. [mm]	0.375 [9.5]	0.375 [9.5]	0.375 [9.5]	0.375 [9.5]
Face Area sq. ft. [sq. m]	13.5 [1.25]	13.5 [1.25]	13.5 [1.25]	13.5 [1.25]
Rows / FPI [FPcm]	2 / 18 [7]	3 / 18 [7]	3 / 18 [7]	3 / 18 [7]
Refrigerant Control	TX Valves	TX Valves	TX Valves	TX Valves
Drain Connection No./Size in. [mm]	1/1 [25.4]	1/1 [25.4]	1/1 [25.4]	1/1 [25.4]
<b>Outdoor Fan—Type</b>	Propeller	Propeller	Propeller	Propeller
No. Used/Diameter in. [mm]	2/24 [609.6]	2/24 [609.6]	2/24 [609.6]	2/24 [609.6]
Drive Type/No. Speeds	Direct/1	Direct/1	Direct/1	Direct/1
CFM [L/s]	8000 [3775]	8000 [3775]	8000 [3775]	8000 [3775]
No. Motors/HP	2 at 1/3 HP	2 at 1/3 HP	2 at 1/3 HP	2 at 1/3 HP
Motor RPM	1075	1075	1075	1075
<b>Indoor Fan—Type</b>	FC Centrifugal	FC Centrifugal	FC Centrifugal	FC Centrifugal
No. Used/Diameter in. [mm]	1/15x15 [381x381]	1/15x15 [381x381]	1/15x15 [381x381]	1/15x15 [381x381]
Drive Type/No. Speeds	Belt/Variable	Belt/Variable	Belt/Variable	Belt/Variable
No. Motors	1	1	1	1
Motor HP	3	2	3	2
Motor RPM	1725	1725	1725	1725
Motor Frame Size	56	56	56	56
<b>Filter—Type</b>	Disposable	Disposable	Disposable	Disposable
Furnished	Yes	Yes	Yes	Yes
(No.) Size Recommended in. [mm]	(6)2x18x18 [51x457x457]	(6)2x18x18 [51x457x457]	(6)2x18x18 [51x457x457]	(6)2x18x18 [51x457x457]
<b>Refrigerant Charge Oz. (Sys. 1/Sys. 2) [g]</b>	154.4/166.6 [4377/4723]	172.8/180.8 [4899/5126]	172.8/180.8 [4899/5126]	172.8/180.8 [4899/5126]
<b>Weights</b>				
Net Weight lbs. [kg]	1059 [480]	1112 [504]	1120 [508]	1112 [504]
Ship Weight lbs. [kg]	1096 [497]	1149 [521]	1157 [525]	1149 [521]

See Page 20 for Notes.

[ ] Designates Metric Conversions



**NOM. SIZES 6-12.5 TONS [21.1-44.0 kW] ASHRAE 90.1-2010 COMPLIANT MODELS**

Model RLNL- Series	B120DM	B120YL	B120YM	B151CL
<b>Cooling Performance<sup>1</sup></b>				<b>CONTINUED →</b>
Gross Cooling Capacity Btu [kW]	123,000 [36.04]	123,000 [36.04]	123,000 [36.04]	156,000 [45.71]
EER/SEER <sup>2</sup>	11.2/NA	11.2/NA	11.2/NA	11.1/NA
Nominal CFM/AHRI Rated CFM [L/s]	4000/3750 [1888/1770]	4000/3750 [1888/1770]	4000/3750 [1888/1770]	5000/4225 [2360/1994]
AHRI Net Cooling Capacity Btu [kW]	118,000 [34.57]	118,000 [34.57]	118,000 [34.57]	150,000 [43.95]
Net Sensible Capacity Btu [kW]	88,800 [26.02]	88,800 [26.02]	88,800 [26.02]	106,600 [31.23]
Net Latent Capacity Btu [kW]	29,200 [8.56]	29,200 [8.56]	29,200 [8.56]	43,400 [12.72]
IEER <sup>3</sup>	11.9	11.9	11.9	10.8
Net System Power kW	10.49	10.49	10.49	13.54
<b>Compressor</b>				
No./Type	2/Scroll	2/Scroll	2/Scroll	2/Scroll
<b>Outdoor Sound Rating (dB)<sup>4</sup></b>				
	88	88	88	88
<b>Outdoor Coil—Fin Type</b>				
Tube Type	Louvered	Louvered	Louvered	Louvered
Tube Size in. [mm] OD	Rifled	Rifled	Rifled	MicroChannel
Tube Size in. [mm] OD	0.375 [9.5]	0.375 [9.5]	0.375 [9.5]	1 [25.4]
Face Area sq. ft. [sq. m]	27 [2.51]	27 [2.51]	27 [2.51]	27 [2.51]
Rows / FPI [FPcm]	2 / 22 [9]	2 / 22 [9]	2 / 22 [9]	2 / 23 [9]
<b>Indoor Coil—Fin Type</b>				
Tube Type	Louvered	Louvered	Louvered	Louvered
Tube Type	Rifled	Rifled	Rifled	Rifled
Tube Size in. [mm]	0.375 [9.5]	0.375 [9.5]	0.375 [9.5]	0.375 [9.5]
Face Area sq. ft. [sq. m]	13.5 [1.25]	13.5 [1.25]	13.5 [1.25]	13.5 [1.25]
Rows / FPI [FPcm]	3 / 18 [7]	3 / 18 [7]	3 / 18 [7]	4 / 15 [6]
Refrigerant Control	TX Valves	TX Valves	TX Valves	TX Valves
Drain Connection No./Size in. [mm]	1/1 [25.4]	1/1 [25.4]	1/1 [25.4]	1/1 [25.4]
<b>Outdoor Fan—Type</b>				
Propeller	Propeller	Propeller	Propeller	Propeller
No. Used/Diameter in. [mm]	2/24 [609.6]	2/24 [609.6]	2/24 [609.6]	2/24 [609.6]
Drive Type/No. Speeds	Direct/1	Direct/1	Direct/1	Direct/1
CFM [L/s]	8000 [3775]	8000 [3775]	8000 [3775]	8000 [3775]
No. Motors/HP	2 at 1/3 HP	2 at 1/3 HP	2 at 1/3 HP	2 at 1/2 HP
Motor RPM	1075	1075	1075	1075
<b>Indoor Fan—Type</b>				
FC Centrifugal	FC Centrifugal	FC Centrifugal	FC Centrifugal	FC Centrifugal
No. Used/Diameter in. [mm]	1/15x15 [381x381]	1/15x15 [381x381]	1/15x15 [381x381]	1/15x15 [381x381]
Drive Type/No. Speeds	Belt/Variable	Belt/Variable	Belt/Variable	Belt/Variable
No. Motors	1	1	1	1
Motor HP	3	2	3	3
Motor RPM	1725	1725	1725	1725
Motor Frame Size	56	56	56	56
<b>Filter—Type</b>				
Disposable	Disposable	Disposable	Disposable	Disposable
Furnished	Yes	Yes	Yes	Yes
(No.) Size Recommended in. [mm]	(6)2x18x18 [51x457x457]	(6)2x18x18 [51x457x457]	(6)2x18x18 [51x457x457]	(6)2x18x18 [51x457x457]
<b>Refrigerant Charge Oz. (Sys. 1/Sys. 2) [g]</b>				
	172.8/180.8 [4899/5126]	172.8/180.8 [4899/5126]	172.8/180.8 [4899/5126]	147.2/152 [4173/4309]
<b>Weights</b>				
Net Weight lbs. [kg]	1120 [508]	1112 [504]	1120 [508]	1230 [558]
Ship Weight lbs. [kg]	1157 [525]	1149 [521]	1157 [525]	1267 [575]

See Page 20 for Notes.

[ ] Designates Metric Conversions



## NOM. SIZES 6-12.5 TONS [21.1-44.0 kW] ASHRAE 90.1-2010 COMPLIANT MODELS

Model RLNL- Series	B151CM	B151DL	B151DM	B151YL
<b>Cooling Performance<sup>1</sup></b>				<b>CONTINUED</b> →
Gross Cooling Capacity Btu [kW]	156,000 [45.71]	156,000 [45.71]	156,000 [45.71]	156,000 [45.71]
EER/SEER <sup>2</sup>	11.1/NA	11.1/NA	11.1/NA	11.1/NA
Nominal CFM/AHRI Rated CFM [L/s]	5000/4225 [2360/1994]	5000/4225 [2360/1994]	5000/4225 [2360/1994]	5000/4225 [2360/1994]
AHRI Net Cooling Capacity Btu [kW]	150,000 [43.95]	150,000 [43.95]	150,000 [43.95]	150,000 [43.95]
Net Sensible Capacity Btu [kW]	106,600 [31.23]	106,600 [31.23]	106,600 [31.23]	106,600 [31.23]
Net Latent Capacity Btu [kW]	43,400 [12.72]	43,400 [12.72]	43,400 [12.72]	43,400 [12.72]
IEER <sup>3</sup>	10.8	10.8	10.8	10.8
Net System Power kW	13.54	13.54	13.54	13.54
<b>Compressor</b>				
No./Type	2/Scroll	2/Scroll	2/Scroll	2/Scroll
<b>Outdoor Sound Rating (dB)<sup>4</sup></b>				
	88	88	88	88
<b>Outdoor Coil—Fin Type</b>				
Tube Type	Louvered	Louvered	Louvered	Louvered
Tube Type	MicroChannel	MicroChannel	MicroChannel	MicroChannel
Tube Size in. [mm] OD	1 [25.4]	1 [25.4]	1 [25.4]	1 [25.4]
Face Area sq. ft. [sq. m]	27 [2.51]	27 [2.51]	27 [2.51]	27 [2.51]
Rows / FPI [FPcm]	2 / 23 [9]	2 / 23 [9]	2 / 23 [9]	2 / 23 [9]
<b>Indoor Coil—Fin Type</b>				
Tube Type	Louvered	Louvered	Louvered	Louvered
Tube Type	Rifled	Rifled	Rifled	Rifled
Tube Size in. [mm]	0.375 [9.5]	0.375 [9.5]	0.375 [9.5]	0.375 [9.5]
Face Area sq. ft. [sq. m]	13.5 [1.25]	13.5 [1.25]	13.5 [1.25]	13.5 [1.25]
Rows / FPI [FPcm]	4 / 15 [6]	4 / 15 [6]	4 / 15 [6]	4 / 15 [6]
Refrigerant Control	TX Valves	TX Valves	TX Valves	TX Valves
Drain Connection No./Size in. [mm]	1/1 [25.4]	1/1 [25.4]	1/1 [25.4]	1/1 [25.4]
<b>Outdoor Fan—Type</b>				
Propeller	Propeller	Propeller	Propeller	Propeller
No. Used/Diameter in. [mm]	2/24 [609.6]	2/24 [609.6]	2/24 [609.6]	2/24 [609.6]
Drive Type/No. Speeds	Direct/1	Direct/1	Direct/1	Direct/1
CFM [L/s]	8000 [3775]	8000 [3775]	8000 [3775]	8000 [3775]
No. Motors/HP	2 at 1/2 HP	2 at 1/2 HP	2 at 1/2 HP	2 at 1/2 HP
Motor RPM	1075	1075	1075	1075
<b>Indoor Fan—Type</b>				
FC Centrifugal	FC Centrifugal	FC Centrifugal	FC Centrifugal	FC Centrifugal
No. Used/Diameter in. [mm]	1/15x15 [381x381]	1/15x15 [381x381]	1/15x15 [381x381]	1/15x15 [381x381]
Drive Type/No. Speeds	Belt/Variable	Belt/Variable	Belt/Variable	Belt/Variable
No. Motors	1	1	1	1
Motor HP	5	3	5	3
Motor RPM	1725	1725	1725	1725
Motor Frame Size	184	56	184	56
<b>Filter—Type</b>				
Disposable	Disposable	Disposable	Disposable	Disposable
Furnished	Yes	Yes	Yes	Yes
(No.) Size Recommended in. [mm]	(6)2x18x18 [51x457x457]	(6)2x18x18 [51x457x457]	(6)2x18x18 [51x457x457]	(6)2x18x18 [51x457x457]
<b>Refrigerant Charge Oz. (Sys. 1/Sys. 2) [g]</b>				
	147.2/152 [4173/4309]	147.2/152 [4173/4309]	147.2/152 [4173/4309]	147.2/152 [4173/4309]
<b>Weights</b>				
Net Weight lbs. [kg]	1238 [562]	1230 [558]	1238 [562]	1230 [558]
Ship Weight lbs. [kg]	1275 [578]	1267 [575]	1275 [578]	1267 [575]

See Page 20 for Notes.

[ ] Designates Metric Conversions

**NOM. SIZES 6-12.5 TONS [21.1-44.0 kW] ASHRAE 90.1-2010 COMPLIANT MODELS**

Model RLNL- Series	B151YM
<b>Cooling Performance<sup>1</sup></b>	
Gross Cooling Capacity Btu [kW]	156,000 [45.71]
EER/SEER <sup>2</sup>	11.1/NA
Nominal CFM/AHRI Rated CFM [L/s]	5000/4225 [2360/1994]
AHRI Net Cooling Capacity Btu [kW]	150,000 [43.95]
Net Sensible Capacity Btu [kW]	106,600 [31.23]
Net Latent Capacity Btu [kW]	43,400 [12.72]
IEER <sup>3</sup>	10.8
Net System Power kW	13.54
<b>Compressor</b>	
No./Type	2/Scroll
<b>Outdoor Sound Rating (dB)<sup>4</sup></b>	
88	
<b>Outdoor Coil—Fin Type</b>	
Louvered	
Tube Type	MicroChannel
Tube Size in. [mm] OD	1 [25.4]
Face Area sq. ft. [sq. m]	27 [2.51]
Rows / FPI [FPcm]	2 / 23 [9]
<b>Indoor Coil—Fin Type</b>	
Louvered	
Tube Type	Rifled
Tube Size in. [mm]	0.375 [9.5]
Face Area sq. ft. [sq. m]	13.5 [1.25]
Rows / FPI [FPcm]	4 / 15 [6]
Refrigerant Control	TX Valves
Drain Connection No./Size in. [mm]	1/1 [25.4]
<b>Outdoor Fan—Type</b>	
Propeller	
No. Used/Diameter in. [mm]	2/24 [609.6]
Drive Type/No. Speeds	Direct/1
CFM [L/s]	8000 [3775]
No. Motors/HP	2 at 1/2 HP
Motor RPM	1075
<b>Indoor Fan—Type</b>	
FC Centrifugal	
No. Used/Diameter in. [mm]	1/15x15 [381x381]
Drive Type/No. Speeds	Belt/Variable
No. Motors	1
Motor HP	5
Motor RPM	1725
Motor Frame Size	184
<b>Filter—Type</b>	
Disposable	
Furnished	Yes
(No.) Size Recommended in. [mm]	(6)2x18x18 [51x457x457]
<b>Refrigerant Charge Oz. (Sys. 1/Sys. 2) [g]</b>	
147.2/152 [4173/4309]	
<b>Weights</b>	
Net Weight lbs. [kg]	1238 [562]
Ship Weight lbs. [kg]	1275 [578]

See Page 20 for Notes.

[ ] Designates Metric Conversions

## NOTES:

1. Cooling Performance is rated at 95° F ambient, 80° F entering dry bulb, 67° F entering wet bulb. Gross capacity does not include the effect of fan motor heat. AHRI capacity is net and includes the effect of fan motor heat. Units are suitable for operation to  $\pm 20\%$  of nominal cfm. Units are certified in accordance with the Unitary Air Conditioner Equipment certification program, which is based on AHRI Standard 340/360.
2. EER and/or SEER are rated at AHRI conditions and in accordance with DOE test procedures.
3. IEER is rated in accordance with AHRI Standard 340/360. Units are rated at 80° F ambient, 80° F entering dry bulb, and 67° F entering wet bulb at AHRI rated cfm.
4. Outdoor Sound Rating shown is tested in accordance with AHRI Standard 270.



# SYSTEMS PERFORMANCE—RLNL-B SERIES

## GROSS SYSTEMS PERFORMANCE DATA—B073

		ENTERING INDOOR AIR @ 80°F [26.7°C] dbE ①									
wbE		71°F [21.7°C]			67°F [19.4°C]			63°F [17.2°C]			
CFM [L/s]		2790 [1317]	2325 [1097]	1860 [878]	2790 [1317]	2325 [1097]	1860 [878]	2790 [1317]	2325 [1097]	1860 [878]	
DR ①		.06	.01	.15	.06	.01	.15	.06	.01	.15	
OUTDOOR DRY BULB TEMPERATURE °F [°C]	75 [23.9]	Total BTUH [kW] Sens BTUH [kW] Power	92.8 [27.2] 58.8 [17.2] 4.7	89.5 [26.2] 50.5 [14.8] 4.6	86.3 [25.3] 42.9 [12.6] 4.5	86.4 [25.3] 67.9 [19.9] 4.6	83.4 [24.4] 59.1 [17.3] 4.5	80.3 [23.5] 50.8 [14.9] 4.5	81.8 [24.0] 75.4 [22.1] 4.6	78.9 [23.1] 66.1 [19.4] 4.5	76.1 [22.3] 57.4 [16.8] 4.4
	80 [26.7]	Total BTUH [kW] Sens BTUH [kW] Power	90.8 [26.6] 58.1 [17.0] 4.9	87.6 [25.7] 49.9 [14.6] 4.8	84.4 [24.7] 42.3 [12.4] 4.7	84.4 [24.7] 67.0 [19.6] 4.9	81.4 [23.8] 58.3 [17.1] 4.8	78.5 [23.0] 50.2 [14.7] 4.7	79.8 [23.4] 74.7 [21.9] 4.8	77.0 [22.6] 65.5 [19.2] 4.7	74.2 [21.7] 56.8 [16.6] 4.7
	85 [29.4]	Total BTUH [kW] Sens BTUH [kW] Power	88.6 [26.0] 57.0 [16.7] 5.2	85.5 [25.1] 49.0 [14.4] 5.1	82.4 [24.1] 41.6 [12.2] 5.0	82.2 [24.1] 66.0 [19.3] 5.1	79.4 [23.3] 57.6 [16.9] 5.1	76.5 [22.4] 49.6 [14.5] 5.0	77.7 [22.8] 73.7 [21.6] 5.1	74.9 [21.9] 64.6 [18.9] 5.0	72.2 [21.2] 56.1 [16.4] 4.9
	90 [32.2]	Total BTUH [kW] Sens BTUH [kW] Power	86.3 [25.3] 55.9 [16.4] 5.5	83.2 [24.4] 48.0 [14.1] 5.4	80.2 [23.5] 40.8 [12.0] 5.3	79.9 [23.4] 64.9 [19.0] 5.4	77.1 [22.6] 56.6 [16.6] 5.3	74.3 [21.8] 48.8 [14.3] 5.2	75.3 [22.1] 72.5 [21.2] 5.4	72.7 [21.3] 63.7 [18.7] 5.3	70.0 [20.5] 55.3 [16.2] 5.2
	95 [35]	Total BTUH [kW] Sens BTUH [kW] Power	83.7 [24.5] 54.4 [15.9] 5.8	80.8 [23.7] 46.9 [13.7] 5.7	77.9 [22.8] 39.9 [11.7] 5.6	77.4 [22.7] 63.6 [18.6] 5.7	74.7 [21.9] 55.5 [16.3] 5.6	71.9 [21.1] 47.8 [14.0] 5.5	72.8 [21.3] 71.2 [20.9] 5.7	70.2 [20.6] 62.5 [18.3] 5.6	67.7 [19.8] 54.4 [15.9] 5.5
	100 [37.8]	Total BTUH [kW] Sens BTUH [kW] Power	81.0 [23.7] 52.9 [15.5] 6.1	78.2 [22.9] 45.6 [13.4] 6.0	75.4 [22.1] 38.8 [11.4] 5.9	74.7 [21.9] 62.1 [18.2] 6.1	72.1 [21.1] 54.2 [15.9] 6.0	69.4 [20.3] 46.7 [13.7] 5.9	70.1 [20.5] 69.6 [20.4] 6.0	67.6 [19.8] 61.2 [17.9] 5.9	65.2 [19.1] 53.3 [15.6] 5.8
	105 [40.6]	Total BTUH [kW] Sens BTUH [kW] Power	78.2 [22.9] 51.3 [15.0] 6.5	75.4 [22.1] 44.1 [12.9] 6.4	72.7 [21.3] 37.5 [11.0] 6.2	71.8 [21.0] 60.2 [17.6] 6.4	69.3 [20.3] 52.6 [15.4] 6.3	66.8 [19.6] 45.4 [13.3] 6.2	67.2 [19.7] 67.2 [19.7] 6.4	64.8 [19.0] 59.7 [17.5] 6.3	62.5 [18.3] 52.0 [15.2] 6.2
	110 [43.3]	Total BTUH [kW] Sens BTUH [kW] Power	75.1 [22.0] 49.2 [14.4] 6.8	72.5 [21.2] 42.4 [12.4] 6.7	69.8 [20.5] 36.0 [10.5] 6.6	68.7 [20.1] 58.3 [17.1] 6.8	66.3 [19.4] 50.9 [14.9] 6.7	63.9 [18.7] 44.0 [12.9] 6.6	64.2 [18.8] 64.2 [18.8] 6.8	61.9 [18.1] 58.0 [17.0] 6.6	59.6 [17.5] 50.5 [14.8] 6.5
	115 [46.1]	Total BTUH [kW] Sens BTUH [kW] Power	71.9 [21.1] 47.1 [13.8] 7.2	69.3 [20.3] 40.5 [11.9] 7.1	66.8 [19.6] 34.5 [10.1] 7.0	65.5 [19.2] 56.2 [16.5] 7.2	63.2 [18.5] 49.1 [14.4] 7.1	60.9 [17.8] 42.4 [12.4] 6.9	60.9 [17.8] 60.9 [17.8] 7.1	58.8 [17.2] 56.2 [16.5] 7.0	56.6 [16.6] 49.0 [14.4] 6.9

## GROSS SYSTEMS PERFORMANCE DATA—B090

		ENTERING INDOOR AIR @ 80°F [26.7°C] dbE ①									
wbE		71°F [21.7°C]			67°F [19.4°C]			63°F [17.2°C]			
CFM [L/s]		3600 [1699]	2775 [1310]	2440 [1152]	3600 [1699]	2775 [1310]	2440 [1152]	3600 [1699]	2775 [1310]	2440 [1152]	
DR ①		.06	.13	.17	.06	.13	.17	.06	.13	.17	
OUTDOOR DRY BULB TEMPERATURE °F [°C]	75 [23.9]	Total BTUH [kW] Sens BTUH [kW] Power	111.2 [32.6] 68.2 [20.0] 5.8	105.5 [30.9] 54.2 [15.9] 5.6	102.9 [30.2] 48.3 [14.2] 5.6	107.2 [31.4] 84.6 [24.8] 5.7	101.7 [29.8] 68.8 [20.2] 5.6	99.2 [29.1] 62.1 [18.2] 5.5	101.3 [29.7] 93.5 [27.4] 5.7	96.1 [28.2] 76.9 [22.5] 5.5	93.8 [27.5] 69.9 [20.5] 5.4
	80 [26.7]	Total BTUH [kW] Sens BTUH [kW] Power	109.7 [32.1] 68.3 [20.0] 6.1	104.0 [30.5] 54.3 [15.9] 6.0	101.5 [29.7] 48.5 [14.2] 5.9	105.7 [31.0] 84.6 [24.8] 6.0	100.3 [29.4] 68.9 [20.2] 5.9	97.8 [28.7] 62.2 [18.2] 5.8	99.8 [29.2] 93.5 [27.4] 6.0	94.7 [27.8] 77.0 [22.6] 5.8	92.3 [27.1] 69.9 [20.5] 5.8
	85 [29.4]	Total BTUH [kW] Sens BTUH [kW] Power	107.7 [31.6] 67.8 [19.9] 6.5	102.2 [30.0] 54.0 [15.8] 6.3	99.7 [29.2] 48.3 [14.2] 6.2	103.7 [30.4] 84.0 [24.6] 6.4	98.4 [28.8] 68.5 [20.1] 6.2	96.0 [28.1] 61.9 [18.2] 6.2	97.8 [28.7] 92.9 [27.2] 6.3	92.8 [27.2] 76.6 [22.5] 6.2	90.5 [26.5] 69.6 [20.4] 6.1
	90 [32.2]	Total BTUH [kW] Sens BTUH [kW] Power	105.3 [30.9] 66.6 [19.5] 6.8	99.9 [29.3] 53.1 [15.6] 6.7	97.5 [28.6] 47.5 [13.9] 6.6	101.4 [29.7] 83.1 [24.4] 6.8	96.2 [28.2] 67.8 [19.9] 6.6	93.8 [27.5] 61.3 [18.0] 6.5	95.4 [28.0] 91.9 [26.9] 6.7	90.5 [26.5] 75.8 [22.2] 6.5	88.3 [25.9] 69.0 [20.2] 6.4
	95 [35]	Total BTUH [kW] Sens BTUH [kW] Power	102.5 [30.0] 65.1 [19.1] 7.2	97.3 [28.5] 52.0 [15.2] 7.0	94.9 [27.8] 46.5 [13.6] 6.9	98.5 [28.9] 81.5 [23.9] 7.2	93.5 [27.4] 66.6 [19.5] 7.0	91.2 [26.7] 60.2 [17.7] 6.9	92.6 [27.1] 90.4 [26.5] 7.1	87.9 [25.8] 74.7 [21.9] 6.9	85.7 [25.1] 67.9 [19.9] 6.8
	100 [37.8]	Total BTUH [kW] Sens BTUH [kW] Power	99.3 [29.1] 63.2 [18.5] 7.6	94.2 [27.6] 50.4 [14.8] 7.4	91.9 [26.9] 45.1 [13.2] 7.3	95.3 [27.9] 79.6 [23.3] 7.6	90.4 [26.5] 65.0 [19.1] 7.4	88.2 [25.8] 58.8 [17.2] 7.3	89.4 [26.2] 88.4 [25.9] 7.5	84.8 [24.9] 73.0 [21.4] 7.3	82.7 [24.2] 66.4 [19.5] 7.2
	105 [40.6]	Total BTUH [kW] Sens BTUH [kW] Power	95.6 [28.0] 60.6 [17.8] 8.1	90.7 [26.6] 48.3 [14.2] 7.9	88.5 [25.9] 43.2 [12.7] 7.8	91.6 [26.8] 77.0 [22.6] 8.0	86.9 [25.5] 62.9 [18.4] 7.8	84.8 [24.9] 57.0 [16.7] 7.7	85.7 [25.1] 85.7 [25.1] 7.9	81.3 [23.8] 71.0 [20.8] 7.7	79.3 [23.2] 64.6 [18.9] 7.6
	110 [43.3]	Total BTUH [kW] Sens BTUH [kW] Power	91.5 [26.8] 57.6 [16.9] 8.5	86.8 [25.4] 45.9 [13.5] 8.3	84.7 [24.8] 41.0 [12.0] 8.2	87.5 [25.6] 73.9 [21.7] 8.4	83.0 [24.3] 60.4 [17.7] 8.2	81.0 [23.7] 54.7 [16.0] 8.1	81.6 [23.9] 81.6 [23.9] 8.4	77.4 [22.7] 68.5 [20.1] 8.2	75.5 [22.1] 62.4 [18.3] 8.1
	115 [46.1]	Total BTUH [kW] Sens BTUH [kW] Power	87.0 [25.5] 54.1 [15.9] 9.0	82.5 [24.2] 43.0 [12.6] 8.8	80.5 [23.6] 38.4 [11.3] 8.6	83.0 [24.3] 70.5 [20.7] 8.9	78.7 [23.1] 57.6 [16.9] 8.7	76.8 [22.5] 52.2 [15.3] 8.6	77.1 [22.6] 77.1 [22.6] 8.8	73.1 [21.4] 65.7 [19.3] 8.6	71.3 [20.9] 59.9 [17.6] 8.5

DR —Depression ratio  
dbE—Entering air dry bulb  
wbE—Entering air wet bulb

Total —Total capacity x 1000 BTUH  
Sens —Sensible capacity x 1000 BTUH  
Power—KW input

NOTES: ① When the entering air dry bulb is other than 80°F [27°C], adjust the sensible capacity from the table by adding  $[1.10 \times \text{CFM} \times (1 - \text{DR}) \times (\text{dbE} - 80)]$ .

[ ] Designates Metric Conversions



## GROSS SYSTEMS PERFORMANCE DATA—B102

		ENTERING INDOOR AIR @ 80°F [26.7°C] ①									
wbE		71°F [21.7°C]			67°F [19.4°C]			63°F [17.2°C]			
CFM [L/s]		4100 [1935]	3200 [1510]	2700 [1274]	4100 [1935]	3200 [1510]	2700 [1274]	4100 [1935]	3200 [1510]	2700 [1274]	
DR ①		0	.05	.08	0	.05	.08	0	.05	.08	
OUTDOOR DRY BULB TEMPERATURE °F [°C]	75 [23.9]	Total BTUH [kW] Sens BTUH [kW] Power	113.8 [33.4] 69.9 [20.5] 6.4	108.3 [31.7] 56.3 [16.5] 6.3	105.2 [30.8] 49.3 [14.5] 6.2	110.1 [32.3] 91.3 [26.8] 6.3	104.7 [30.7] 75.3 [22.1] 6.2	101.7 [29.8] 67.0 [19.6] 6.1	105.0 [30.8] 103.1 [30.2] 6.2	99.9 [29.3] 86.0 [25.2] 6.1	97.0 [28.4] 77.0 [22.6] 6.0
	80 [26.7]	Total BTUH [kW] Sens BTUH [kW] Power	113.7 [33.3] 71.7 [21.0] 6.7	108.2 [31.7] 57.9 [17.0] 6.6	105.1 [30.8] 50.8 [14.9] 6.5	110.0 [32.2] 93.1 [27.3] 6.7	104.6 [30.7] 76.9 [22.5] 6.5	101.7 [29.8] 68.6 [20.1] 6.4	104.9 [30.7] 104.9 [30.8] 6.6	99.8 [29.2] 87.6 [25.7] 6.4	96.9 [28.4] 78.5 [23.0] 6.3
	85 [29.4]	Total BTUH [kW] Sens BTUH [kW] Power	112.9 [33.1] 72.6 [21.3] 7.1	107.5 [31.5] 58.8 [17.2] 6.9	104.4 [30.6] 51.6 [15.1] 6.8	109.2 [32.0] 94.0 [27.6] 7.0	103.9 [30.5] 77.8 [22.8] 6.8	101.0 [29.6] 69.4 [20.3] 6.7	104.1 [30.5] 104.1 [30.5] 6.9	99.1 [29.0] 88.5 [25.9] 6.7	96.2 [28.2] 79.4 [23.3] 6.7
	90 [32.2]	Total BTUH [kW] Sens BTUH [kW] Power	111.5 [32.7] 72.9 [21.4] 7.4	106.1 [31.1] 59.0 [17.3] 7.3	103.1 [30.2] 51.9 [15.2] 7.2	107.8 [31.6] 94.2 [27.6] 7.4	102.5 [30.0] 78.0 [22.9] 7.2	99.6 [29.2] 69.6 [20.4] 7.1	102.7 [30.1] 102.7 [30.1] 7.3	97.7 [28.6] 88.7 [26.0] 7.1	94.9 [27.8] 79.6 [23.3] 7.0
	95 [35]	Total BTUH [kW] Sens BTUH [kW] Power	109.4 [32.1] 72.2 [21.2] 7.8	104.1 [30.5] 58.5 [17.2] 7.6	101.1 [29.6] 51.5 [15.1] 7.5	105.7 [31.0] 93.6 [27.4] 7.7	100.5 [29.5] 77.5 [22.7] 7.6	97.7 [28.6] 69.3 [20.3] 7.4	100.6 [29.5] 100.6 [29.5] 7.7	95.7 [28.0] 88.2 [25.9] 7.5	93.0 [27.3] 79.3 [23.3] 7.4
	100 [37.8]	Total BTUH [kW] Sens BTUH [kW] Power	106.6 [31.2] 70.7 [20.7] 8.2	101.4 [29.7] 57.3 [16.8] 8.0	98.6 [28.9] 50.5 [14.8] 7.9	102.9 [30.2] 92.1 [27.0] 8.1	97.9 [28.7] 76.4 [22.4] 8.0	95.1 [27.9] 68.2 [20.0] 7.8	97.8 [28.7] 97.8 [28.7] 8.1	93.0 [27.3] 87.0 [25.5] 7.9	90.4 [26.5] 78.2 [22.9] 7.8
	105 [40.6]	Total BTUH [kW] Sens BTUH [kW] Power	103.2 [30.2] 68.4 [20.1] 8.7	98.1 [28.8] 55.4 [16.2] 8.4	95.4 [28.0] 48.9 [14.3] 8.3	99.4 [29.1] 89.7 [26.3] 8.6	94.6 [27.7] 74.5 [21.8] 8.4	91.9 [26.9] 66.6 [19.5] 8.2	94.3 [27.6] 94.3 [27.6] 8.5	89.8 [26.3] 85.2 [25.0] 8.3	87.2 [25.6] 76.6 [22.5] 8.2
	110 [43.3]	Total BTUH [kW] Sens BTUH [kW] Power	99.0 [29.0] 65.2 [19.1] 9.1	94.2 [27.6] 52.8 [15.5] 8.9	91.5 [26.8] 46.4 [13.6] 8.8	95.3 [27.9] 86.7 [25.4] 9.0	90.7 [26.6] 72.0 [21.1] 8.8	88.1 [25.8] 64.3 [18.9] 8.7	90.2 [26.4] 90.2 [26.4] 8.9	85.8 [25.1] 82.5 [24.2] 8.7	83.4 [24.4] 74.3 [21.8] 8.6
	115 [46.1]	Total BTUH [kW] Sens BTUH [kW] Power	94.2 [27.6] 61.3 [18.0] 9.6	89.6 [26.3] 49.6 [14.5] 9.3	87.1 [25.5] 43.7 [12.8] 9.2	90.5 [26.5] 82.7 [24.2] 9.5	86.1 [25.2] 68.7 [20.1] 9.3	83.7 [24.5] 61.5 [18.0] 9.1	85.4 [25.0] 85.4 [25.0] 9.4	81.3 [23.8] 79.4 [23.3] 9.2	78.9 [23.1] 71.4 [20.9] 9.1

## GROSS SYSTEMS PERFORMANCE DATA—B120

		ENTERING INDOOR AIR @ 80°F [26.7°C] dbE ①									
wbE		71°F [21.7°C]			67°F [19.4°C]			63°F [17.2°C]			
CFM [L/s]		4800 [2265]	3750 [1770]	3200 [1510]	4800 [2265]	3750 [1770]	3200 [1510]	4800 [2265]	3750 [1770]	3200 [1510]	
DR ①		0	.03	.07	0	.03	.07	0	.03	.07	
OUTDOOR DRY BULB TEMPERATURE °F [°C]	75 [23.9]	Total BTUH [kW] Sens BTUH [kW] Power	149.3 [43.8] 99.7 [29.2] 7.3	142.1 [41.6] 81.0 [23.7] 7.2	138.3 [40.5] 71.9 [21.1] 7.1	139.6 [40.9] 117.9 [34.6] 7.2	132.8 [38.9] 97.5 [28.6] 7.0	129.3 [37.9] 87.6 [25.7] 6.9	130.9 [38.4] 130.9 [38.4] 7.1	124.6 [36.5] 109.7 [32.2] 6.9	121.3 [35.5] 99.1 [29.1] 6.8
	80 [26.7]	Total BTUH [kW] Sens BTUH [kW] Power	147.2 [43.1] 99.2 [29.1] 7.8	140.0 [41.0] 80.5 [23.6] 7.6	136.3 [39.9] 71.5 [21.0] 7.5	137.4 [40.3] 117.1 [34.3] 7.7	130.8 [38.3] 97.0 [28.4] 7.5	127.3 [37.3] 87.1 [25.5] 7.4	128.8 [37.7] 128.8 [37.8] 7.6	122.6 [35.9] 109.3 [32.0] 7.4	119.3 [35.0] 98.7 [28.9] 7.3
	85 [29.4]	Total BTUH [kW] Sens BTUH [kW] Power	144.7 [42.4] 98.0 [28.7] 8.3	137.7 [40.4] 79.7 [23.4] 8.1	134.0 [39.3] 70.8 [20.8] 8.0	135.0 [39.6] 116.2 [34.1] 8.2	128.5 [37.7] 96.3 [28.2] 8.0	125.0 [36.6] 86.4 [25.3] 7.9	126.4 [37.0] 126.4 [37.1] 8.0	120.2 [35.2] 108.4 [31.8] 7.8	117.0 [34.3] 98.0 [28.7] 7.7
	90 [32.2]	Total BTUH [kW] Sens BTUH [kW] Power	142.0 [41.6] 96.8 [28.4] 8.8	135.1 [39.6] 78.7 [23.1] 8.6	131.5 [38.5] 70.0 [20.5] 8.5	132.3 [38.8] 114.9 [33.7] 8.7	125.9 [36.9] 95.2 [27.9] 8.5	122.5 [35.9] 85.5 [25.1] 8.4	123.6 [36.2] 123.6 [36.2] 8.6	117.7 [34.5] 107.5 [31.5] 8.4	114.5 [33.6] 97.2 [28.5] 8.3
	95 [35]	Total BTUH [kW] Sens BTUH [kW] Power	139.0 [40.7] 95.1 [27.9] 9.4	132.3 [38.8] 77.4 [22.7] 9.1	128.8 [37.7] 68.8 [20.2] 9.0	129.3 [37.9] 113.2 [33.2] 9.2	123.0 [36.0] 93.8 [27.5] 9.0	119.7 [35.1] 84.3 [24.7] 8.9	120.7 [35.4] 120.7 [35.4] 9.1	114.8 [33.6] 106.1 [31.1] 8.9	111.8 [32.8] 96.0 [28.1] 8.8
	100 [37.8]	Total BTUH [kW] Sens BTUH [kW] Power	135.8 [39.8] 93.1 [27.3] 9.9	129.2 [37.9] 75.7 [22.2] 9.7	125.7 [36.8] 67.3 [19.7] 9.6	126.0 [36.9] 111.1 [32.6] 9.8	119.9 [35.1] 92.2 [27.0] 9.6	116.7 [34.2] 82.9 [24.3] 9.5	117.4 [34.4] 117.4 [34.4] 9.7	111.7 [32.7] 104.4 [30.6] 9.5	108.7 [31.9] 94.5 [27.7] 9.3
	105 [40.6]	Total BTUH [kW] Sens BTUH [kW] Power	132.2 [38.7] 90.7 [26.6] 10.6	125.8 [36.9] 73.8 [21.6] 10.3	122.5 [35.9] 65.7 [19.3] 10.2	122.5 [35.9] 108.8 [31.9] 10.4	116.5 [34.1] 90.2 [26.4] 10.2	113.4 [33.2] 81.1 [23.8] 10.1	113.8 [33.4] 113.8 [33.4] 10.3	108.3 [31.7] 102.5 [30.0] 10.1	105.4 [30.9] 92.8 [27.2] 9.9
	110 [43.3]	Total BTUH [kW] Sens BTUH [kW] Power	128.4 [37.6] 88.0 [25.8] 11.2	122.2 [35.8] 71.6 [21.0] 10.9	118.9 [34.8] 63.6 [18.6] 10.8	118.7 [34.8] 106.2 [31.1] 11.1	112.9 [33.1] 88.1 [25.8] 10.8	109.9 [32.2] 79.3 [23.3] 10.7	110.0 [32.2] 110.0 [32.2] 11.0	104.7 [30.7] 100.3 [29.4] 10.7	101.9 [29.9] 90.8 [26.6] 10.6
	115 [46.1]	Total BTUH [kW] Sens BTUH [kW] Power	124.3 [36.4] 85.0 [24.9] 11.9	118.3 [34.7] 69.2 [20.3] 11.6	115.1 [33.7] 61.5 [18.0] 11.4	114.6 [33.6] 103.1 [30.2] 11.7	109.0 [31.9] 85.6 [25.1] 11.5	106.1 [31.1] 77.0 [22.6] 11.3	105.9 [31.0] 105.9 [31.0] 11.6	100.8 [29.5] 97.9 [28.7] 11.3	98.1 [28.8] 88.7 [26.0] 11.2

DR —Depression ratio  
dbE—Entering air dry bulb  
wbE—Entering air wet bulb

Total —Total capacity x 1000 BTUH  
Sens —Sensible capacity x 1000 BTUH  
Power—KW input

NOTES: ① When the entering air dry bulb is other than 80°F [27°C], adjust the sensible capacity from the table by adding [1.10 x CFM x (1 - DR) x (dbE - 80)].

[ ] Designates Metric Conversions



**GROSS SYSTEMS PERFORMANCE DATA—B151**

		ENTERING INDOOR AIR @ 80°F [26.7°C] ①									
wbE		71°F [21.7°C]			67°F [19.4°C]			63°F [17.2°C]			
CFM [L/s]		5800 [2737]	4225 [1994]	3800 [1793]	5800 [2737]	4225 [1994]	3800 [1793]	5800 [2737]	4225 [1994]	3800 [1793]	
DR ①		0	.03	.06	0	.03	.06	0	.03	.06	
OUTDOOR DRY BULB TEMPERATURE °F [°C]	75 [23.9]	Total BTUH [kW] Sens BTUH [kW] Power	196.8 [57.7] 135.5 [39.7] 10.2	184.4 [54.0] 103.0 [30.2] 9.9	181.0 [53.0] 94.9 [27.8] 9.8	186.8 [54.7] 156.7 [45.9] 10.0	175.0 [51.3] 121.7 [35.7] 9.7	171.8 [50.3] 112.9 [33.1] 9.6	178.6 [52.3] 177.9 [52.1] 9.7	167.3 [49.0] 140.2 [41.1] 9.4	164.2 [48.1] 130.7 [38.3] 9.3
	80 [26.7]	Total BTUH [kW] Sens BTUH [kW] Power	192.1 [56.3] 132.7 [38.9] 10.7	179.9 [52.7] 100.8 [29.6] 10.3	176.6 [51.8] 92.9 [27.2] 10.3	182.1 [53.4] 153.9 [45.1] 10.5	170.6 [50.0] 119.6 [35.1] 10.1	167.4 [49.1] 110.9 [32.5] 10.0	173.9 [51.0] 173.9 [51.0] 10.2	162.9 [47.7] 138.2 [40.5] 9.9	159.9 [46.9] 128.9 [37.8] 9.8
	85 [29.4]	Total BTUH [kW] Sens BTUH [kW] Power	187.2 [54.9] 129.7 [38.0] 11.2	175.3 [51.4] 98.6 [28.9] 10.9	172.1 [50.4] 90.9 [26.7] 10.8	177.2 [51.9] 151.1 [44.3] 11.0	166.0 [48.6] 117.5 [34.4] 10.6	162.9 [47.7] 109.0 [32.0] 10.5	169.0 [49.5] 169.0 [49.5] 10.7	158.3 [46.4] 136.0 [39.9] 10.4	155.4 [45.5] 126.9 [37.2] 10.3
	90 [32.2]	Total BTUH [kW] Sens BTUH [kW] Power	182.1 [53.4] 126.8 [37.2] 11.8	170.5 [50.0] 96.4 [28.3] 11.4	167.4 [49.1] 88.9 [26.1] 11.3	172.1 [50.4] 148.0 [43.4] 11.5	161.2 [47.2] 115.2 [33.8] 11.2	158.2 [46.4] 106.9 [31.3] 11.1	163.9 [48.0] 163.9 [48.0] 11.3	153.5 [45.0] 133.7 [39.2] 10.9	150.7 [44.2] 124.8 [36.6] 10.8
	95 [35]	Total BTUH [kW] Sens BTUH [kW] Power	176.8 [51.8] 123.6 [36.2] 12.3	165.6 [48.5] 94.1 [27.6] 11.9	162.5 [47.6] 86.7 [25.4] 11.8	166.8 [48.9] 144.9 [42.5] 12.1	156.2 [45.8] 112.8 [33.1] 11.7	153.3 [44.9] 104.7 [30.7] 11.6	158.6 [46.5] 158.6 [46.5] 11.9	148.5 [43.5] 131.3 [38.5] 11.5	145.8 [42.7] 122.6 [35.9] 11.4
	100 [37.8]	Total BTUH [kW] Sens BTUH [kW] Power	171.3 [50.2] 120.3 [35.3] 13.0	160.4 [47.0] 91.6 [26.9] 12.5	157.5 [46.2] 84.5 [24.8] 12.4	161.3 [47.3] 141.6 [41.5] 12.7	151.0 [44.3] 110.3 [32.3] 12.3	148.3 [43.5] 102.5 [30.0] 12.2	153.1 [44.9] 153.1 [44.9] 12.5	143.3 [42.0] 128.8 [37.8] 12.1	140.7 [41.2] 120.3 [35.3] 12.0
	105 [40.6]	Total BTUH [kW] Sens BTUH [kW] Power	165.6 [48.5] 116.9 [34.3] 13.6	155.1 [45.5] 89.1 [26.1] 13.2	152.2 [44.6] 82.2 [24.1] 13.0	155.6 [45.6] 138.2 [40.5] 13.4	145.7 [42.7] 107.8 [31.6] 12.9	143.0 [41.9] 100.2 [29.4] 12.8	147.4 [43.2] 147.4 [43.2] 13.1	138.0 [40.4] 126.3 [37.0] 12.7	135.5 [39.7] 118.0 [34.6] 12.6
	110 [43.3]	Total BTUH [kW] Sens BTUH [kW] Power	159.7 [46.8] 113.4 [33.2] 14.3	149.6 [43.8] 86.5 [25.4] 13.8	146.8 [43.0] 79.8 [23.4] 13.7	149.7 [43.9] 134.7 [39.5] 14.0	140.2 [41.1] 105.2 [30.8] 13.6	137.6 [40.3] 97.8 [28.7] 13.5	141.5 [41.5] 141.5 [41.5] 13.8	132.5 [38.8] 123.7 [36.3] 13.4	130.1 [38.1] 115.6 [33.9] 13.3
	115 [46.1]	Total BTUH [kW] Sens BTUH [kW] Power	153.6 [45.0] 109.8 [32.2] 15.0	143.9 [42.2] 83.8 [24.6] 14.5	141.2 [41.4] 77.3 [22.7] 14.4	143.6 [42.1] 131.0 [38.4] 14.7	134.5 [39.4] 102.5 [30.0] 14.3	132.0 [38.7] 95.3 [27.9] 14.2	135.4 [39.7] 135.4 [39.7] 14.5	126.8 [37.2] 121.0 [35.5] 14.1	124.5 [36.5] 113.1 [33.2] 13.9

DR —Depression ratio  
dbE—Entering air dry bulb  
wbE—Entering air wet bulb

Total —Total capacity x 1000 BTUH  
Sens —Sensible capacity x 1000 BTUH  
Power—KW input

NOTES: ① When the entering air dry bulb is other than 80°F [27°C], adjust the sensible capacity from the table by adding [1.10 x CFM x (1 - DR) x (dbE - 80)].

[ ] Designates Metric Conversions



## AIRFLOW PERFORMANCE—6 TON [21.1 kW] B073

Air Flow CFM [L/s]		External Static Pressure—Inches of Water [kPa]																												
		0.1 [0.02]		0.2 [0.05]		0.3 [0.07]		0.4 [0.10]		0.5 [0.12]		0.6 [0.15]		0.7 [0.17]		0.8 [0.20]		0.9 [0.22]		1.0 [0.25]		1.1 [0.27]		1.2 [0.30]		1.3 [0.32]		1.4 [0.35]		1.5 [0.37]
RPM	W	RPM	W	RPM	W	RPM	W	RPM	W	RPM	W	RPM	W	RPM	W	RPM	W	RPM	W	RPM	W	RPM	W	RPM	W	RPM	W	RPM	W	
1800 [849]	—	—	—	—	—	—	—	—	—	—	—	—	—	—	—	—	—	—	—	—	—	—	—	—	—	—	—	—	—	
1900 [897]	—	—	—	—	—	—	—	—	—	—	—	—	—	—	—	—	—	—	—	—	—	—	—	—	—	—	—	—	—	—
2000 [944]	—	—	—	—	—	—	—	—	—	—	—	—	—	—	—	—	—	—	—	—	—	—	—	—	—	—	—	—	—	—
2100 [991]	—	—	—	—	—	—	—	—	—	—	—	—	—	—	—	—	—	—	—	—	—	—	—	—	—	—	—	—	—	—
2200 [1038]	—	—	—	—	—	—	—	—	—	—	—	—	—	—	—	—	—	—	—	—	—	—	—	—	—	—	—	—	—	—
2300 [1085]	—	—	—	—	—	—	—	—	—	—	—	—	—	—	—	—	—	—	—	—	—	—	—	—	—	—	—	—	—	—
2400 [1133]	—	—	—	—	—	—	—	—	—	—	—	—	—	—	—	—	—	—	—	—	—	—	—	—	—	—	—	—	—	—
2500 [1180]	805	751	852	826	897	900	940	973	981	1046	1021	1118	1059	1188	1095	1258	1129	1327	1162	1395	1192	1462	1221	1529	1248	1504	1273	1658	—	—
2600 [1227]	831	813	877	890	922	967	964	1043	1005	1118	1044	1191	1081	1265	1116	1337	1149	1408	1181	1478	1211	1548	1239	1616	1265	1684	—	—	—	—
2700 [1274]	858	878	904	958	947	1037	989	1115	1029	1192	1067	1268	1103	1344	1137	1418	1170	1492	1201	1565	1230	1637	1257	1708	1282	1778	—	—	—	—
2800 [1321]	886	947	931	1029	973	1110	1014	1190	1053	1270	1091	1349	1126	1426	1160	1503	1191	1579	1221	1654	1250	1728	1276	1802	—	—	—	—	—	—

NOTE: L-Drive left of bold line, M-Drive right of bold line.

Drive Package	L					M					
	0	1	2	3	4	0	1	2	3	4	5
Motor H.P. [W]	1.5 [1118.6]					1.5 [1118.6]					
Blower Sheave	AK66					AK66					
Motor Sheave	1VP-44					1VP-50					
Turns Open	0	1	2	3	4	0	1	2	3	4	5
RPM	1119	1072	<b>1019</b>	967	915	859	807	757	707	657	607
				1215	1163	1113	1064	1015			

- NOTES: 1. Factory sheave settings are shown in bold type.  
 2. Do not set motor sheave below minimum turns open shown.  
 3. Re-adjustment of sheave required to achieve rated airflow at AHRI minimum E.S.P.  
 4. Drive data shown is for horizontal airflow with dry coil. Add component resistance to duct resistance to determine total E.S.P.

## AIRFLOW CORRECTION FACTORS 6 TON [21.1 kW]

ACTUAL—CFM [L/s]	1800 [849]	2000 [944]	2200 [1038]	2400 [1133]	2600 [1227]	2800 [1277]
TOTAL MBH	0.97	0.96	0.99	1.00	1.01	1.02
SENSIBLE MBH	0.91	0.94	0.97	1.00	1.02	1.05
POWER kW	0.99	0.99	0.99	1.00	1.00	1.01

- NOTES: 1. Multiply correction factor times gross performance data.  
 2. Resulting sensible capacity cannot exceed total capacity.

### [ ] Designates Metric Conversions

## COMPONENT AIR RESISTANCE, IWC 7.5 TONS [26.4 kW]

Component	Standard Indoor Airflow—CFM [L/s]												
	2400 [1133]	2600 [1227]	2800 [1321]	3000 [1416]	3200 [1510]	3400 [1604]	3600 [1699]	Resistance—Inches Water [kPa]					
Wet Coil	0.047 [0.12]	0.051 [0.013]	0.055 [0.014]	0.060 [0.015]	0.065 [0.016]	0.071 [0.018]	0.076 [0.019]						
Concentric Diffuser RXRN-FA65 or FA75 & Transition RXMC-CD04	DNA	.017 [0.042]	.020 [0.050]	.025 [0.062]	.031 [0.077]	.037 [0.092]	DNA						
Concentric Diffuser RXRN-AA61 or AA71 & Transition RXMC-CE05	DNA	DNA	DNA	DNA	DNA	DNA	.017 [0.042]						
Economizer	0.05 [0.012]	0.06 [0.015]	0.07 [0.017]	0.08 [0.020]	0.09 [0.022]	0.10 [0.025]	0.11 [0.027]						
100% R.A. Damper Open	0.03 [0.007]	0.04 [0.009]	0.04 [0.010]	0.05 [0.011]	0.05 [0.012]	0.06 [0.014]	0.06 [0.015]						
Horizontal Economizer	0.08 [0.020]	0.08 [0.020]	0.08 [0.020]	0.10 [0.020]	0.11 [0.021]	0.12 [0.030]	0.13 [0.032]						
100% O.A. Damper Open	0.08 [0.020]	0.08 [0.020]	0.08 [0.020]	0.10 [0.020]	0.11 [0.021]	0.12 [0.030]	0.13 [0.032]						

NOTE: Add component resistance to duct resistance to determine total external static pressure.  
 DNA = Data not Available.





## AIRFLOW PERFORMANCE—8.5 TON [29.9 kW]

Capacity Air Flow CFM [L/s]	8.5 Ton [29.9 kW]																			
	External Static Pressure—Inches of Water [kPa]																			
	0.1 [0.02]	0.2 [0.05]	0.3 [0.07]	0.4 [0.10]	0.5 [0.12]	0.6 [0.15]	0.7 [0.17]	0.8 [0.20]	0.9 [0.22]	1.0 [0.25]	1.1 [0.27]	1.2 [0.30]	1.3 [0.32]	1.4 [0.35]	1.5 [0.37]	1.6 [0.40]	1.7 [0.42]	1.8 [0.45]	1.9 [0.47]	2.0 [0.50]
2700 [1274]	—	—	—	—	—	—	—	—	—	—	—	—	—	—	—	—	—	—	—	—
2800 [1321]	—	—	—	—	—	—	—	—	—	—	—	—	—	—	—	—	—	—	—	—
2900 [1369]	—	—	—	—	—	—	—	—	—	—	—	—	—	—	—	—	—	—	—	—
3000 [1416]	—	—	—	—	—	—	—	—	—	—	—	—	—	—	—	—	—	—	—	—
3100 [1463]	—	—	—	—	—	—	—	—	—	—	—	—	—	—	—	—	—	—	—	—
3200 [1510]	—	—	—	—	—	—	—	—	—	—	—	—	—	—	—	—	—	—	—	—
3300 [1557]	—	—	—	—	—	—	—	—	—	—	—	—	—	—	—	—	—	—	—	—
3400 [1605]	—	—	—	—	—	—	—	—	—	—	—	—	—	—	—	—	—	—	—	—
3500 [1652]	—	—	—	—	—	—	—	—	—	—	—	—	—	—	—	—	—	—	—	—
3600 [1699]	—	—	—	—	—	—	—	—	—	—	—	—	—	—	—	—	—	—	—	—
3700 [1746]	—	—	—	—	—	—	—	—	—	—	—	—	—	—	—	—	—	—	—	—
3800 [1793]	—	—	—	—	—	—	—	—	—	—	—	—	—	—	—	—	—	—	—	—
3900 [1841]	—	—	—	—	—	—	—	—	—	—	—	—	—	—	—	—	—	—	—	—
4000 [1888]	—	—	—	—	—	—	—	—	—	—	—	—	—	—	—	—	—	—	—	—
4100 [1935]	—	—	—	—	—	—	—	—	—	—	—	—	—	—	—	—	—	—	—	—

NOTE: L-Drive left of bold line, M-Drive right of bold line.

Drive Package	L						M					
Motor H.P. [W]	2.0 [1491.4]						3.0 [2237.1]					
Blower Sheave	BK90						BK65					
Motor Sheave	1VP-44						1VP-44					
Turns Open	1	2	3	4	5	6	1	2	3	4	5	6
RPM	860	<b>824</b>	791	757	723	690	1148	1098	1049	999	949	<b>899</b>

- NOTES: 1. Factory sheave settings are shown in bold print.  
 2. Re-adjustment of sheave required to achieve rated airflow at AHR1 minimum E.S.P.  
 3. Do not operate above blower RPM shown as motor overloading will occur.  
 4. Do not set motor sheave below one turn open.

## COMPONENT AIR RESISTANCE, IWC 8.5 TON [29.9 kW]

Component	Standard Indoor Airflow—CFM [L/s]											
	2600 [1227]	2800 [1321]	3000 [1416]	3200 [1510]	3400 [1604]	3600 [1699]	3800 [1793]	4000 [1888]	4200 [1982]	Resistance—Inches Water [kPa]		
Wet Coil	0.051 [0.013]	0.055 [0.014]	0.060 [0.015]	0.065 [0.016]	0.071 [0.018]	0.076 [0.019]	0.082 [0.020]	0.087 [0.022]	0.093 [0.023]	DNA		
Concentric Diffuser RXRN-FA65 or FA75 & Transition RXMC-CD04	0.17 [0.042]	0.20 [0.050]	0.25 [0.062]	0.31 [0.077]	0.37 [0.092]	DNA	DNA	DNA	DNA	DNA		
Concentric Diffuser RXRN-AA61 or AA71 & Transition RXMC-CE05	DNA	DNA	DNA	DNA	DNA	0.17 [0.042]	0.18 [0.045]	0.21 [0.052]	0.24 [0.060]	DNA		
Economizer	0.06 [0.015]	0.07 [0.017]	0.08 [0.020]	0.09 [0.022]	0.10 [0.025]	0.11 [0.027]	0.12 [0.030]	0.13 [0.032]	0.14 [0.035]	DNA		
100% R.A. Damper Open	0.04 [0.009]	0.04 [0.010]	0.05 [0.011]	0.05 [0.012]	0.06 [0.014]	0.06 [0.015]	0.07 [0.017]	0.08 [0.020]	0.09 [0.021]	DNA		
Horizontal Economizer	0.08 [0.020]	0.08 [0.020]	0.10 [0.024]	0.11 [0.027]	0.12 [0.030]	0.13 [0.032]	0.15 [0.036]	0.16 [0.040]	0.18 [0.044]	DNA		
100% O.A. Damper Open	0.08 [0.020]	0.08 [0.020]	0.10 [0.024]	0.11 [0.027]	0.12 [0.030]	0.13 [0.032]	0.15 [0.036]	0.16 [0.040]	0.18 [0.044]	DNA		

NOTE: Add component resistance to duct resistance to determine total external static pressure.  
 DNA = Data not Available.

## AIRFLOW CORRECTION FACTORS 8.5 TON [29.9 kW]

ACTUAL—CFM [L/s]	2600 [1227]	2800 [1321]	3000 [1416]	3200 [1510]	3400 [1605]	3600 [1699]	3800 [1793]	4000 [1888]	4200 [1982]
TOTAL MBH	0.96	0.97	0.98	0.99	1.00	1.01	1.02	1.03	1.04
SENSIBLE MBH	0.88	0.91	0.94	0.97	1.00	1.03	1.05	1.07	1.09
POWER kW	0.99	0.99	0.99	1.00	1.00	1.01	1.01	1.02	1.03

- NOTES: 1. Multiply correction factor times gross performance data.  
 2. Resulting sensible capacity cannot exceed total capacity.

[ ] Designates Metric Conversions





## AIRFLOW PERFORMANCE—12.5 TON [44.0 kW]

Air Flow CFM [L/s]		External Static Pressure—Inches of Water [kPa]																				
		Voltage 208/230, 460, 575 — 3 phase 60 Hz																				
		0.1 [0.2]	0.2 [0.05]	0.3 [0.07]	0.4 [0.10]	0.5 [0.12]	0.6 [0.15]	0.7 [0.17]	0.8 [0.20]	0.9 [0.22]	1.0 [0.25]	1.1 [0.27]	1.2 [0.30]	1.3 [0.32]	1.4 [0.35]	1.5 [0.37]	1.6 [0.40]	1.7 [0.42]	1.8 [0.45]	1.9 [0.47]	2.0 [0.50]	
3800 [1793]	—	—	—	—	—	—	—	—	—	—	—	—	—	—	—	—	—	—	—	—	—	
4000 [1888]	—	—	—	—	—	—	—	—	—	—	—	—	—	—	—	—	—	—	—	—	—	
4200 [1982]	—	—	—	—	—	—	—	—	—	—	—	—	—	—	—	—	—	—	—	—	—	
4400 [2076]	836	2029	862	2096	886	2167	911	2241	936	2319	960	2400	984	2485	1008	2573	1031	2664	1055	2759	1078	2858
4600 [2171]	867	2263	891	2337	916	2415	940	2496	964	2581	988	2669	1012	2760	1035	2855	1058	2954	1081	3056	1104	3161
4800 [2265]	897	2518	922	2599	946	2684	970	2772	993	2864	1017	2959	1040	3057	1063	3159	1086	3265	1108	3373	1131	3485
5000 [2359]	929	2795	953	2883	976	2975	1000	3070	1023	3168	1046	3270	1069	3375	1091	3484	1114	3597	1136	3712	1158	3831
5200 [2454]	961	3093	984	3188	1007	3286	1030	3388	1053	3494	1076	3603	1098	3715	1120	3831	1142	3950	1164	4072	1186	4199
5400 [2548]	993	3412	1016	3514	1039	3619	1062	3728	1084	3841	1106	3956	1128	4076	1150	4198	1171	4324	1193	4454	1214	4587
5600 [2643]	1026	3752	1049	3861	1071	3974	1093	4089	1115	4209	1137	4331	1159	4458	1180	4587	1201	4720	1222	4857	1243	4987
5800 [2737]	1060	4114	1082	4230	1104	4349	1126	4472	1147	4598	1169	4728	1190	4861	1211	4997	1232	5137	1252	5281	1272	5428

NOTE: L-Drive left of bold line, M-Drive right of bold line.

Drive Package	L						M					
Motor H.P. [W]	3.0 [2237.1]						5.0 [3728.5]					
Blower Sheave	BK72H						BK85H					
Motor Sheave	1VP-44						1VP-65					
Turns Open	1	2	3	4	5	6	1	2	3	4	5	6
RPM	1051	1009	966	920	876	824	1294	1256	1216	1177	1136	1094

NOTES: 1. Factory sheave settings are shown in bold print.

2. Do not set motor sheave below minimum or maximum turns open shown.

3. Re-adjustment of sheave required to achieve rated airflow at AHRI minimum External Static Pressure.

4. Drive data shown is for horizontal airflow with dry coil. Add component resistance (below) to duct resistance to determine total External Static Pressure.

## AIRFLOW CORRECTION FACTORS 12.5 TON [44.0 kW]

ACTUAL—CFM [L/s]	3800 [1793]	4000 [1888]	4200 [1982]	4400 [2077]	4600 [2171]	4800 [2265]	5000 [2360]	5200 [2454]	5400 [2549]	5600 [2643]	5800 [2737]
TOTAL MBH	0.98	0.99	1.00	1.01	1.02	1.02	1.03	1.04	1.05	1.06	1.07
SENSIBLE MBH	0.93	0.96	1.00	1.04	1.07	1.11	1.14	1.18	1.21	1.25	1.28
POWER KW	0.99	1.00	1.00	1.00	1.01	1.01	1.02	1.02	1.03	1.03	1.03

NOTES: 1. Multiply correction factor times gross performance data.

2. Resulting sensible capacity cannot exceed total capacity.

### [ ] Designates Metric Conversions

## COMPONENT AIR RESISTANCE, IWC 12.5 TON [44.0 kW]

Component	Standard Indoor Airflow—CFM [L/s]											
	3800 [1793]	4000 [1888]	4200 [1982]	4400 [2076]	4600 [2171]	4800 [2265]	5000 [2359]	5200 [2454]	5400 [2548]	5600 [2643]	5800 [2737]	
	Resistance—Inches Water [kPa]											
Wet Coil	0.08	0.09	0.09	0.10	0.10	0.11	0.11	0.12	0.13	0.13	0.14	
Downflow Economizer	0.12	0.13	0.14	0.15	0.16	0.17	0.18	0.19	0.20	0.21	0.22	
RA Damper Open	0.03	0.03	0.03	0.04	0.04	0.04	0.04	0.05	0.05	0.05	0.05	
Horizontal Economizer	0.07	0.07	0.08	0.08	0.09	0.10	0.10	0.11	0.11	0.12	0.13	
RA Damper Open	0.02	0.02	0.02	0.02	0.02	0.02	0.02	0.02	0.03	0.03	0.03	
Concentric Grill RXRN-AA61 or RXRN-AA71	0.19	0.21	0.24	0.27	0.30	0.33	0.36	0.40	0.44	0.48	0.52	
Transition RXMC-CE05	0.05	0.05	0.05	0.07	0.07	0.08	0.09	0.10	0.11	0.12	0.13	
Concentric Grill RXRN-AA66 or RXRN-AA76	0.23	0.25	0.27	0.29	0.30	0.32	0.34	0.36	0.38	0.40	0.43	
Transition RXMC-CF06	0.06	0.06	0.07	0.07	0.07	0.08	0.08	0.08	0.09	0.09	0.10	

NOTE: Add component resistance to duct resistance to determine total external static pressure.



<b>ELECTRICAL DATA – RLNL SERIES</b>										
		<b>B073CL</b>	<b>B073CM</b>	<b>B073DL</b>	<b>B073DM</b>	<b>B073YL</b>	<b>B073YM</b>	<b>B090CL</b>	<b>B090CM</b>	<b>B090CN</b>
<b>Unit Information</b>	Unit Operating Voltage Range	187-253	187-253	414-506	414-506	518-632	518-632	187-253	187-253	187-253
	Volts	208/230	208/230	460	460	575	575	208/230	208/230	208/230
	Minimum Circuit Ampacity	35/35	35/35	16	16	13	13	43/43	43/43	48/48
	Minimum Overcurrent Protection Device Size	40/40	40/40	20	20	15	15	45/45	45/45	50/50
	Maximum Overcurrent Protection Device Size	50/50	50/50	20	20	15	15	50/50	50/50	60/60
<b>Compressor Motor</b>	No.	1	1	1	1	1	1	2	2	2
	Volts	200/240	200/240	480	480	600	600	200/240	200/240	200/240
	Phase	3	3	3	3	3	3	3	3	3
	RPM	3450	3450	3450	3450	3450	3450	3450	3450	3450
	HP, Compressor 1	6	6	6	6	6	6	3 1/4	3 1/4	3 1/4
	Amps (RLA), Comp. 1	19.6/19.6	19.6/19.6	8.2	8.2	6.6	6.6	13.1/13.1	13.1/13.1	13.1/13.1
	Amps (LRA), Comp. 1	136/136	136/136	66.1	66.1	55.3	55.5	83.1/83.1	83.1/83.1	83.1/83.1
<b>Condenser Motor</b>	No.	2	2	2	2	2	2	2	2	2
	Volts	208/230	208/230	460	460	575	575	208/230	208/230	208/230
	Phase	1	1	1	1	1	1	1	1	1
	HP	1/3	1/3	1/3	1/3	1/3	1/3	1/3	1/3	1/3
	Amps (FLA, each)	2.4/2.4	2.4/2.4	1.4	1.4	1	1	1.2/1.2	1.2/1.2	1.2/1.2
	Amps (LRA, each)	4.7/4.7	4.7/4.7	2.4	2.4	1.5	1.5	4.7/4.7	4.7/4.7	4.7/4.7
<b>Evaporator Fan</b>	No.	1	1	1	1	1	1	1	1	1
	Volts	208/230	208/230	460	460	575	575	208/230	208/230	208/230
	Phase	3	3	3	3	3	3	3	3	3
	HP	1 1/2	1 1/2	1 1/2	1 1/2	1 1/2	1 1/2	2	2	3
	Amps (FLA, each)	5.6/5.6	5.6/5.6	2.8	2.8	1.9	1.9	1.9	1.9	13/13
	Amps (LRA, each)	28.8/28.8	28.8/28.8	14.4	14.4	14	14	56/56	56/56	74.5/74.5



## ELECTRICAL DATA – RLNL SERIES

		B090DL	B090DM	B090DN	B090YL	B090YM	B090YN	B102CL	B102CM	B102DL
<b>Unit Information</b>	Unit Operating Voltage Range	414-506	414-506	414-506	518-632	518-632	518-632	187-253	187-253	414-506
	Volts	460	460	460	575	575	575	208/230	208/230	460
	Minimum Circuit Ampacity	21	21	24	16	16	21	49/49	54/54	23
	Minimum Overcurrent Protection Device Size	25	25	25	20	20	25	50/50	55/55	25
	Maximum Overcurrent Protection Device Size	25	25	30	20	20	25	60/60	60/60	25
<b>Compressor Motor</b>	No.	2	2	2	2	2	2	2	2	2
	Volts	480	480	480	600	600	600	200/230	200/230	460
	Phase	3	3	3	3	3	3	3	3	3
	RPM	3450	3450	3450	3450	3450	3450	3450	3450	3450
	HP, Compressor 1	3 1/4	3 1/4	3 1/4	3 1/4	3 1/4	3 1/4	3 3/4	3 3/4	3 3/4
	Amps (RLA), Comp. 1	6.1	6.1	6.1	4.4	4.4	4.4	16/16	16/16	7.1
	Amps (LRA), Comp. 1	41	41	41	33	33	33	91/91	91/91	46
	HP, Compressor 2	3 1/4	3 1/4	3 1/4	3 1/4	3 1/4	3 1/4	3 3/4	3 3/4	3 3/4
	Amps (FLA, each)	6.1	6.1	6.1	4.4	4.4	4.4	16/16	16/16	7.1
Amps (LRA, each)	41	41	41	33	33	33	91/91	91/91	46	
<b>Condenser Motor</b>	No.	2	2	2	2	2	2	2	2	2
	Volts	460	460	460	575	575	575	208/230	208/230	460
	Phase	1	1	1	1	1	1	1	1	1
	HP	1/3	1/3	1/3	1/3	1/3	1/3	1/3	1/3	1/3
	Amps (FLA, each)	0.7	0.7	0.7	0.5	0.5	0.5	1.2/1.2	1.2/1.2	0.7
	Amps (LRA)	2.4	2.4	2.4	1.5	1.5	1.5	4.7/4.7	4.7/4.7	2.4
<b>Evaporator Fan</b>	No.	1	1	1	1	1	1	1	1	1
	Volts	460	460	460	575	575	575	208/230	208/230	460
	Phase	3	3	3	3	3	3	3	3	3
	HP	2	2	3	2	2	3	2	3	2
	Amps (FLA, each)	4	4	7	4	4	8	8/8	13/13	4
	Amps (LRA, each)	28	28	38.1	19	19	20	56/56	74.5/74.5	28



<b>ELECTRICAL DATA – RLNL SERIES</b>										
		<b>B102DM</b>	<b>B102YL</b>	<b>B102YM</b>	<b>B120CL</b>	<b>B120CM</b>	<b>B120DL</b>	<b>B120DM</b>	<b>B120YL</b>	<b>B120YM</b>
<b>Unit Information</b>	Unit Operating Voltage Range	414-506	518-632	518-632	187-253	187-253	414-506	414-506	518-632	518-632
	Volts	460	575	575	208/230	208/230	460	460	575	575
	Minimum Circuit Ampacity	26	19	24	49/49	54/54	25	28	19	24
	Minimum Overcurrent Protection Device Size	30	20	25	50/50	55/55	25	30	20	25
	Maximum Overcurrent Protection Device Size	30	20	30	60/60	60/60	30	35	20	30
<b>Compressor Motor</b>	No.	2	2	2	2	2	2	2	2	2
	Volts	460	575	575	200/240	200/240	480	480	575	575
	Phase	3	3	3	3	3	3	3	3	3
	RPM	3450	3450	3450	3450	3450	3450	3450	3450	3450
	HP, Compressor 1	3 3/4	3 3/4	3 3/4	4 1/4	4 1/4	4 1/4	4 1/4	4 1/4	4 1/4
	Amps (RLA), Comp. 1	7.1	5.6	5.6	16/16	16/16	9.8	9.8	5.7	5.7
	Amps (LRA), Comp. 1	46	37	37	110/110	110/110	52	52	38.9	38.9
	HP, Compressor 2	3 3/4	3 3/4	3 3/4	4 1/4	4 1/4	4 1/4	4 1/4	4 1/4	4 1/4
	Amps (FLA, each)	7.1	5.6	5.6	16/16	16/16	9.8	9.8	5.7	5.7
Amps (LRA, each)	46	37	37	110/110	110/110	52	52	38.9	38.9	
<b>Condenser Motor</b>	No.	2	2	2	2	2	2	2	2	2
	Volts	460	575	575	208/230	208/230	460	460	575	575
	Phase	1	1	1	1	1	1	1	1	1
	HP	1/3	1/3	1/3	1/3	1/3	1/3	1/3	1/3	1/3
	Amps (FLA, each)	0.7	0.5	0.5	1.2/1.2	1.2/1.2	0.7	0.7	0.5	0.5
	Amps (LRA)	2.4	1.5	1.5	4.7/4.7	4.7/4.7	2.4	2.4	1.5	1.5
<b>Evaporator Fan</b>	No.	1	1	1	1	1	1	1	1	1
	Volts	460	575	575	208/230	208/230	460	460	575	575
	Phase	3	3	3	3	3	3	3	3	3
	HP	3	2	3	2	3	2	3	2	3
	Amps (FLA, each)	7	4	8	8/8	13/13	4	7	4	8
	Amps (LRA, each)	38.1	19	20	56/56	74.5/74.5	28	38.1	19	20



ELECTRICAL DATA – RLNL SERIES							
		B151CL	B151CM	B151DL	B151DM	B151YL	B151YM
Unit Information	Unit Operating Voltage Range	187-253	187-253	414-506	414-506	518-632	518-632
	Volts	208/230	208/230	460	460	575	575
	Minimum Circuit Ampacity	67/67	71/71	33	36	28	28
	Minimum Overcurrent Protection Device Size	70/70	75/75	35	40	30	30
	Maximum Overcurrent Protection Device Size	80/80	90/90	40	45	35	35
Compressor Motor	No.	2	2	2	2	2	2
	Volts	208/230	208/230	460	460	575	575
	Phase	3	3	3	3	3	3
	RPM	3450	3450	3450	3450	3450	3450
	HP, Compressor 1	5 3/4	5 3/4	5 3/4	5 3/4	5 3/4	5 3/4
	Amps (RLA), Comp. 1	22.4/22.4	22.4/22.4	10.6	10.6	7.7	7.7
	Amps (LRA), Comp. 1	149/149	149/149	75	75	54	54
	HP, Compressor 2	5 1/4	5 1/4	5 1/4	5 1/4	5 1/4	5 1/4
	Amps (FLA, each)	19/19	19/19	9.7	9.7	7.4	7.4
	Amps (LRA, each)	123/123	123/123	62	62	50	50
Condenser Motor	No.	2	2	2	2	2	2
	Volts	208/230	208/230	460	460	575	575
	Phase	1	1	1	1	1	1
	HP	1/2	1/2	1/2	1/2	1/2	1/2
	Amps (FLA, each)	1.15/1.15	1.15/1.15	0.75	0.75	0.5	0.5
	Amps (LRA)	5.6/5.6	5.6/5.6	3.1	3.1	2.2	2.2
Evaporator Fan	No.	1	1	1	1	1	1
	Volts	208/230	208/230	460	460	575	575
	Phase	3	3	3	3	3	3
	HP	3	5	3	5	3	5
	Amps (FLA, each)	15/15	18.8/18.8	7	10	8	8
	Amps (LRA, each)	74.5/74.5	82.6/82.6	38.1	41.3	20	33



# UNITS WITH HEATER KITS—RLNL-B SERIES

208/240 VOLT, THREE PHASE, 60 HZ, AUXILIARY ELECTRIC HEATER KITS CHARACTERISTICS AND APPLICATION													
Separate Power Supply For Both Unit and Heater Kit													
Unit Model No. RLNL-	Single Power Supply For Both Unit and Heater Kit						Air Conditioner						
	Heater Kit			Heater			Air Conditioner			Air Conditioner			
	RXJJ-Heater Kit Nominal kW	No. of Sequence Steps	Rated Heater kW @ 208/240 V	Heater KBTU/Hr @ 208/240 V	Heater Amp. @ 208/240 V	Unit Min. Ampacity @ 208/240 V	Over Current Protective Device Size Min./Max. @ 208 V	Over Current Protective Device Size Min./Max. @ 240 V	Min. Ckt. Ampacity 208/240 V	Max. Fuse Size 208/240 V	Min. Circuit Ampacity 208/240 V	Over Current Protective Device Size Min./Max. @ 208 V	Over Current Protective Device Size Min./Max. @ 240 V
B073CL	No Heat	—	—	—	—	35/35	40/50	40/50	—	—	35/35	40/50	40/50
	CC10C	1	7.2/9.6	24.56/32.75	20/23.1	35/36	45/50	45/50	25/29	25/30	—	—	—
	CC15C	1	10.8/14.4	36.84/49.13	30/34.6	45/51	60/60	60/60	38/44	40/45	—	—	—
	CC20C	1	14.4/19.2	49.13/65.5	40/46.2	57/65	70/70	70/70	50/58	50/60	—	—	—
	CC30C	1	21.6/28.8	73.69/98.25	60/69.3	82/94	100/100	100/100	75/87	80/90	—	—	—
B090CL	No Heat	—	—	—	—	43/43	45/50	45/50	—	—	43/43	45/50	45/50
	CC10C	1	7.2/9.6	24.56/32.75	20/23.1	43/43	50/50	50/50	25/29	25/30	—	—	—
	CC15C	1	10.8/14.4	36.84/49.13	30/34.6	48/54	60/60	60/60	38/44	40/45	—	—	—
	CC20C	1	14.4/19.2	49.13/65.5	40/46.2	60/68	70/70	70/70	50/58	50/60	—	—	—
	CC30C	1	21.6/28.8	73.69/98.25	60/69.3	85/97	90/90	100/100	75/87	80/90	—	—	—
B102CL	CC40C	1	28.8/38.4	98.25/131	80.1/92.4	111/126	125/125	150/150	101/116	110/125	—	—	—
	No Heat	—	—	—	—	49/49	50/60	50/60	—	—	49/49	50/60	50/60
	CC10C	1	7.2/9.6	24.56/32.75	20/23.1	49/49	60/60	60/60	25/29	25/30	—	—	—
	CC15C	1	10.8/14.4	36.84/49.13	30/34.6	49/54	60/60	60/60	38/44	40/45	—	—	—
	CC20C	1	14.4/19.2	49.13/65.5	40/46.2	60/68	70/70	70/70	50/58	50/60	—	—	—
B120CL	CC30C	1	21.6/28.8	73.69/98.25	60/69.3	85/97	90/90	100/100	75/87	80/90	—	—	—
	CC40C	1	28.8/38.4	98.25/131	80.1/92.4	111/126	125/125	150/150	101/116	110/125	—	—	—
	CC50C	1	36.1/48	123.16/163.75	100.1/115.5	136/155	150/150	175/175	126/145	150/150	—	—	—
	No Heat	—	—	—	—	49/49	50/60	50/60	—	—	49/49	50/60	50/60
	CC10C	1	7.2/9.6	24.56/32.75	20/23.1	49/49	60/60	60/60	25/29	25/30	—	—	—
B151CL	CC15C	1	10.8/14.4	36.84/49.13	30/34.6	49/54	60/60	60/60	38/44	40/45	—	—	—
	CC20C	1	14.4/19.2	49.13/65.5	40/46.2	60/68	70/70	70/70	50/58	50/60	—	—	—
	CC30C	1	21.6/28.8	73.69/98.25	60/69.3	85/97	90/90	100/100	75/87	80/90	—	—	—
	CC40C	1	28.8/38.4	98.25/131	80.1/92.4	111/126	125/125	150/150	101/116	110/125	—	—	—
	CC50C	1	36.1/48	123.16/163.75	100.1/115.5	136/155	150/150	175/175	126/145	150/150	—	—	—

\*= For Canadian use only. Uses "P" fuses for inductive circuit.  
+ = Field installed only.

# UNITS WITH HEATER KITS—RLNL-B SERIES



208/240 VOLT, THREE PHASE, 60 HZ, AUXILIARY ELECTRIC HEATER KITS CHARACTERISTICS AND APPLICATION														
Single Power Supply For Both Unit and Heater Kit														
Unit Model No. RLNL-	Heater Kit					Air Conditioner					Separate Power Supply For Both Unit and Heater Kit			
	RXJ-J-Heater Kit Nominal kW	No. of Sequence Steps	Rated Heater kW @ 208/240 V	Heater KBTU/HR @ 208/240 V	Heater Amp. @ 208/240 V	Unit Min. Ampacity @ 208/240 V	Over Current Protective Device Size Min./Max. @ 208 V	Over Current Protective Device Size Min./Max. @ 240 V	Min. Ckt. Ampacity 208/240 V	Max. Fuse Size 208/240 V	Min. Circuit Ampacity 208/240 V	Over Current Protective Device Size Min./Max. @ 208 V	Over Current Protective Device Size Min./Max. @ 240 V	
B073CM	No Heat	—	—	—	—	35/35	40/50	40/50	—	—	35/35	40/50	40/50	
	CC10C	1	7.2/9.6	24.56/32.75	20/23.1	35/36	45/50	45/50	25/29	25/30	—	—	—	
	CC15C	1	10.8/14.4	36.84/49.13	30/34.6	45/51	45/50	60/60	38/44	40/45	—	—	—	
	CC20C	1	14.4/19.2	49.13/65.5	40/46.2	57/65	60/60	70/70	50/58	50/60	—	—	—	
	CC30C	1	21.6/28.8	73.69/98.25	60/69.3	82/94	90/90	100/100	75/87	80/90	—	—	—	
B090CM	No Heat	—	—	—	—	43/43	45/50	45/50	—	—	43/43	45/50	45/50	
	CC10C	1	7.2/9.6	24.56/32.75	20/23.1	43/43	50/50	50/50	25/29	25/30	—	—	—	
	CC15C	1	10.8/14.4	36.84/49.13	30/34.6	48/54	50/50	60/60	38/44	40/45	—	—	—	
	CC20C	1	14.4/19.2	49.13/65.5	40/46.2	60/68	60/60	70/70	50/58	50/60	—	—	—	
	CC30C	1	21.6/28.8	73.69/98.25	60/69.3	85/97	90/90	100/100	75/87	80/90	—	—	—	
B102CM	No Heat	—	—	—	—	111/126	125/125	150/150	101/116	110/125	—	—	—	
	CC10C	1	7.2/9.6	24.56/32.75	20/23.1	54/54	55/60	60/60	—	—	54/54	55/60	55/60	
	CC15C	1	10.8/14.4	36.84/49.13	30/34.6	54/60	60/60	60/60	25/29	25/30	—	—	—	
	CC20C	1	14.4/19.2	49.13/65.5	40/46.2	67/75	70/70	80/80	38/44	40/45	—	—	—	
	CC30C	1	21.6/28.8	73.69/98.25	60/69.3	92/103	100/100	110/110	50/58	50/60	—	—	—	
B120CM	No Heat	—	—	—	—	117/132	125/125	150/150	101/116	110/125	—	—	—	
	CC10C	1	7.2/9.6	24.56/32.75	20/23.1	54/54	55/60	60/60	—	—	54/54	55/60	55/60	
	CC15C	1	10.8/14.4	36.84/49.13	30/34.6	54/60	60/60	60/60	25/29	25/30	—	—	—	
	CC20C	1	14.4/19.2	49.13/65.5	40/46.2	67/75	70/70	80/80	38/44	40/45	—	—	—	
	CC30C	1	21.6/28.8	73.69/98.25	60/69.3	92/103	100/100	110/110	50/58	50/60	—	—	—	
B151CM	No Heat	—	—	—	—	142/161	150/150	175/175	126/145	150/150	—	—	—	
	CC10C	1	7.2/9.6	24.56/32.75	20/23.1	71/71	75/90	80/90	—	—	71/71	75/90	75/90	
	CC15C	1	10.8/14.4	36.84/49.13	30/34.6	71/71	80/90	80/90	25/29	25/30	—	—	—	
	CC20C	1	14.4/19.2	49.13/65.5	40/46.2	74/82	80/90	90/90	38/44	40/45	—	—	—	
	CC30C	1	21.6/28.8	73.69/98.25	60/69.3	99/111	100/100	125/125	50/58	50/60	—	—	—	
CC40C	1	28.8/38.4	98.25/131	80.1/92.4	117/132	124/140	150/150	101/116	110/125	—	—	—	—	
	CC50C	1	36.1/48	123.16/163.75	100.1/115.5	149/168	150/150	126/145	150/150	—	—	—	—	

\*= For Canadian use only. Uses "pr" fuses for inductive circuit.  
 += Field installed only.

## 480 VOLT, THREE PHASE, 60 HZ, AUXILIARY ELECTRIC HEATER KITS CHARACTERISTICS AND APPLICATION

Single Power Supply For Both Unit and Heater Kit										Separate Power Supply For Both Unit and Heater Kit										
Unit Model No. RLNL-	Heater Kit					Air Conditioner					Heater Kit					Air Conditioner				
	RXJJ-Heater Kit Nominal kW	No. of Sequence Steps	Rated Heater kW @ 480 V	Heater KBTU/Hr @ 480 V	Heater Amp. @ 480 V	Unit Min. Ckt. Ampacity @ 480 V	Over Current Protective Device Size Min./Max. @ 480 V	Min. Circuit Ampacity 480 V	Max. Fuse Size 480 V	Min. Ckt. Ampacity 480 V	Over Current Protective Device Size Min./Max. @ 480 V	Min. Circuit Ampacity 480 V	Max. Fuse Size 480 V	Min. Ckt. Ampacity 480 V	Over Current Protective Device Size Min./Max. @ 480 V	Min. Circuit Ampacity 480 V	Max. Fuse Size 480 V	Min. Ckt. Ampacity 480 V	Over Current Protective Device Size Min./Max. @ 480 V	
B073DL	No Heat	—	—	—	—	16	20/20	16	—	—	20/20	—	—	—	16	—	—	—	—	
	CC10D	1	9.6	32.75	11.5	18	20/20	18	15	—	20/20	15	15	—	—	—	—	—	—	
	CC15D	1	14.4	49.13	17.3	26	30/30	26	25	—	30/30	25	25	—	—	—	—	—	—	
	CC20D	1	19.2	65.5	23.1	33	35/35	33	30	—	35/35	30	30	—	—	—	—	—	—	
	CC30D	1	28.8	98.25	34.6	47	50/50	47	45	—	50/50	45	45	—	—	—	—	—	—	
B090DL	No Heat	—	—	—	—	21	25/25	21	—	—	25/25	—	—	—	21	—	—	—	—	
	CC10D	1	9.6	32.75	11.5	21	25/25	21	15	—	25/25	15	15	—	—	—	—	—	—	
	CC15D	1	14.4	49.13	17.3	27	30/30	27	25	—	30/30	25	25	—	—	—	—	—	—	
	CC20D	1	19.2	65.5	23.1	34	35/35	34	30	—	35/35	30	30	—	—	—	—	—	—	
	CC30D	1	28.8	98.25	34.6	49	50/50	49	45	—	50/50	45	45	—	—	—	—	—	—	
B102DL	No Heat	—	—	—	—	23	25/25	23	—	—	25/25	—	—	—	23	—	—	—	—	
	CC10D	1	9.6	32.75	11.5	23	25/25	23	15	—	25/25	15	15	—	—	—	—	—	—	
	CC15D	1	14.4	49.13	17.3	27	30/30	27	25	—	30/30	25	25	—	—	—	—	—	—	
	CC20D	1	19.2	65.5	23.1	34	35/35	34	30	—	35/35	30	30	—	—	—	—	—	—	
	CC30D	1	28.8	98.25	34.6	49	50/50	49	45	—	50/50	45	45	—	—	—	—	—	—	
B120DL	No Heat	—	—	—	—	25	25/30	25	—	—	25/30	—	—	—	25	—	—	—	—	
	CC10D	1	9.6	32.75	11.5	25	30/30	25	15	—	30/30	15	15	—	—	—	—	—	—	
	CC15D	1	14.4	49.13	17.3	27	30/30	27	25	—	30/30	25	25	—	—	—	—	—	—	
	CC20D	1	19.2	65.5	23.1	34	35/35	34	30	—	35/35	30	30	—	—	—	—	—	—	
	CC30D	1	28.8	98.25	34.6	49	50/50	49	45	—	50/50	45	45	—	—	—	—	—	—	
B151DL	No Heat	—	—	—	—	33	35/40	33	—	—	35/40	—	—	—	33	—	—	—	—	
	CC10D	1	9.6	32.75	11.5	33	40/40	33	15	—	40/40	15	15	—	—	—	—	—	—	
	CC15D	1	14.4	49.13	17.3	33	40/40	33	25	—	40/40	25	25	—	—	—	—	—	—	
	CC20D	1	19.2	65.5	23.1	38	40/40	38	30	—	40/40	30	30	—	—	—	—	—	—	
	CC30D	1	28.8	98.25	34.6	52	60/60	52	45	—	60/60	45	45	—	—	—	—	—	—	
B151DL	No Heat	—	—	—	—	67	70/70	67	46.2	—	70/70	46.2	60	—	—	—	—	—	—	
	CC40D	1	38.4	131	46.2	67	70/70	67	58	—	70/70	58	60	—	—	—	—	—	—	
	CC50D	1	48	163.75	57.7	81	90/90	81	73	—	90/90	73	80	—	—	—	—	—	—	

\*= For Canadian use only. Uses "P" fuses for inductive circuit.  
+ = Field installed only.

# UNITS WITH HEATER KITS—RLNL-B SERIES



## 480 VOLT, THREE PHASE, 60 HZ, AUXILIARY ELECTRIC HEATER KITS CHARACTERISTICS AND APPLICATION

Unit Model No. RLNL-	Single Power Supply For Both Unit and Heater Kit						Separate Power Supply For Both Unit and Heater Kit						
	Heater Kit			Air Conditioner			Heater Kit			Air Conditioner			
	RXJJ- Heater Kit Nominal kW	No. of Sequence Steps	Rated Heater kW @ 480 V	Heater KBTU/Hr @ 480 V	Heater Amp. @ 480 V	Unit Min. Ckt. Ampacity @ 480 V	Over Current Protective Device Size Min./Max. @ 480 V	Min. Ckt. Ampacity 480 V	Max. Fuse Size 480 V	Over Current Protective Device Size Min./Max. @ 480 V	Min. Ckt. Ampacity 480 V	Max. Fuse Size 480 V	Over Current Protective Device Size Min./Max. @ 480 V
B073DM	No Heat	—	—	—	—	16	20/20	—	—	20/20	16	—	20/20
	CC10D	1	9.6	32.75	11.5	18	20/20	—	15	—	—	15	—
	CC15D	1	14.4	49.13	17.3	26	30/30	—	22	—	—	22	—
	CC20D	1	19.2	65.5	23.1	33	35/35	—	29	—	—	29	—
	CC30D	1	28.8	98.25	34.6	47	50/50	—	44	—	—	44	—
B090DM	No Heat	—	—	—	—	21	25/25	—	—	25/25	21	—	25/25
	CC10D	1	9.6	32.75	11.5	21	25/25	—	15	—	—	15	—
	CC15D	1	14.4	49.13	17.3	27	30/30	—	22	—	—	22	—
	CC20D	1	19.2	65.5	23.1	34	35/35	—	29	—	—	29	—
	CC30D	1	28.8	98.25	34.6	49	50/50	—	44	—	—	44	—
B102DM	No Heat	—	—	—	—	26	30/30	—	—	30/30	26	—	30/30
	CC10D	1	9.6	32.75	11.5	26	30/30	—	15	—	—	15	—
	CC15D	1	14.4	49.13	17.3	31	35/35	—	22	—	—	22	—
	CC20D	1	19.2	65.5	23.1	38	40/40	—	29	—	—	29	—
	CC30D	1	28.8	98.25	34.6	52	60/60	—	44	—	—	44	—
B120DM	No Heat	—	—	—	—	67	70/70	—	—	70/70	58	—	—
	CC10D	1	9.6	32.75	11.5	28	30/35	—	15	—	—	15	—
	CC15D	1	14.4	49.13	17.3	31	35/35	—	22	—	—	22	—
	CC20D	1	19.2	65.5	23.1	38	40/40	—	29	—	—	29	—
	CC30D	1	28.8	98.25	34.6	52	60/60	—	44	—	—	44	—
B151DM	No Heat	—	—	—	—	81	90/90	—	—	90/90	73	—	—
	CC10D	1	9.6	32.75	11.5	28	40/45	—	15	—	—	15	—
	CC15D	1	14.4	49.13	17.3	36	40/45	—	22	—	—	22	—
	CC20D	1	19.2	65.5	23.1	42	45/45	—	29	—	—	29	—
	CC30D	1	28.8	98.25	34.6	56	60/60	—	44	—	—	44	—
B151DM	No Heat	—	—	—	—	85	90/90	—	—	90/90	73	—	—
	CC10D	1	9.6	32.75	11.5	36	40/45	—	15	—	—	15	—
	CC15D	1	14.4	49.13	17.3	36	40/45	—	22	—	—	22	—
	CC20D	1	19.2	65.5	23.1	42	45/45	—	29	—	—	29	—
	CC30D	1	28.8	98.25	34.6	56	60/60	—	44	—	—	44	—

\*= For Canadian use only. Uses "pr" fuses for inductive circuit.  
+ = Field installed only.



# UNITS WITH HEATER KITS—RLNL-B SERIES

## 600 VOLT, THREE PHASE, 60 HZ, AUXILIARY ELECTRIC HEATER KITS CHARACTERISTICS AND APPLICATION

Unit Model No. RLNL-	Single Power Supply For Both Unit and Heater Kit						Separate Power Supply For Both Unit and Heater Kit						
	Heater Kit			Air Conditioner			Heater Kit			Air Conditioner			
	RXJJ- Heater Kit Nominal kW	No. of Sequence Steps	Rated Heater kW @ 600 V	Heater kBTU/Hr @ 600 V	Heater Amp. @ 600 V	Unit Min. Ckt. Ampacity @ 600 V	Over Current Protective Device Size Min./Max. @ 600 V	Min. Circuit Ampacity 600 V	Max. Fuse Size 600 V	Over Current Protective Device Size Min./Max. @ 600 V	Min. Circuit Ampacity 600 V	Max. Fuse Size 600 V	Over Current Protective Device Size Min./Max. @ 600 V
B073YL	No Heat	—	—	—	—	13	15/15	13	—	15/15	—	—	—
	CC10Y	1	9.6	32.75	9.2	14	20/20	—	15	—	—	—	—
	CC15Y	1	14.4	49.13	13.9	20	20/20	—	20	—	—	—	—
	CC20Y	1	19.2	65.5	18.5	26	30/30	—	25	—	—	—	—
	CC30Y	1	28.8	98.25	27.7	38	40/40	—	35	—	—	—	—
B090YL	No Heat	—	—	—	—	16	20/20	16	—	20/20	—	—	—
	CC10Y	1	9.6	32.75	9.2	17	20/20	—	15	—	—	—	—
	CC15Y	1	14.4	49.13	13.9	23	25/25	—	20	—	—	—	—
	CC20Y	1	19.2	65.5	18.5	29	30/30	—	25	—	—	—	—
	CC30Y	1	28.8	98.25	27.7	40	40/40	—	35	—	—	—	—
B102YL	No Heat	—	—	—	—	19	20/20	19	—	20/20	—	—	—
	CC10Y	1	9.6	32.75	9.2	19	20/20	—	15	—	—	—	—
	CC15Y	1	14.4	49.13	13.9	23	25/25	—	20	—	—	—	—
	CC20Y	1	19.2	65.5	18.5	29	30/30	—	25	—	—	—	—
	CC30Y	1	28.8	98.25	27.7	40	40/40	—	35	—	—	—	—
B120YL	No Heat	—	—	—	—	19	20/20	19	—	20/20	—	—	—
	CC10Y	1	9.6	32.75	9.2	19	25/25	—	15	—	—	—	—
	CC15Y	1	14.4	49.13	13.9	23	25/25	—	20	—	—	—	—
	CC20Y	1	19.2	65.5	18.5	29	30/30	—	25	—	—	—	—
	CC30Y	1	28.8	98.25	27.7	40	40/40	—	35	—	—	—	—
B151YL	No Heat	—	—	—	—	28	30/35	28	—	30/35	—	—	—
	CC10Y	1	9.6	32.75	9.2	28	30/35	—	15	—	—	—	—
	CC15Y	1	14.4	49.13	13.9	28	30/35	—	20	—	—	—	—
	CC20Y	1	19.2	65.5	18.5	34	35/35	—	25	—	—	—	—
	CC30Y	1	28.8	98.25	27.7	45	45/45	—	35	—	—	—	—
	CC40Y	1	38.4	131	37	57	60/60	—	50	—	—	—	—
	CC50Y	1	48	163.75	46.2	68	70/70	—	60	—	—	—	—

\*= For Canadian use only. Uses "Pr" fuses for inductive circuit.  
 += Field installed only.

# UNITS WITH HEATER KITS—RLNL-B SERIES



## 600 VOLT, THREE PHASE, 60 HZ, AUXILIARY ELECTRIC HEATER KITS CHARACTERISTICS AND APPLICATION

Single Power Supply For Both Unit and Heater Kit										Separate Power Supply For Both Unit and Heater Kit				
Unit Model No. RLNL-	Heater Kit			Air Conditioner			Heater Kit			Air Conditioner				
	RXJJ-Heater Kit Nominal kW	No. of Sequence Steps	Rated Heater kW @ 600 V	Heater KBTU/Hr @ 600 V	Heater Amp. @ 600 V	Unit Min. Ckt. Ampacity @ 600 V	Over Current Protective Device Size Min./Max. @ 600 V	Min. Ckt. Ampacity 600 V	Max. Fuse Size 600 V	Min. Circuit Ampacity 600 V	Over Current Protective Device Size Min./Max. @ 600 V	Min./Max. @ 600 V	Min./Max. @ 600 V	
B073YM	No Heat	—	—	—	—	13	15/15	—	—	13	15/15	—		
	CC10Y	1	9.6	32.75	9.2	14	20/20	12	15	—	—	—		
	CC15Y	1	14.4	49.13	13.9	20	20/20	18	20	—	—	—		
	CC20Y	1	19.2	65.5	18.5	26	30/30	24	25	—	—	—		
	CC30Y	1	28.8	98.25	27.7	38	40/40	35	35	—	—	—		
B090YM	No Heat	—	—	—	—	16	20/20	—	—	16	20/20	—		
	CC10Y	1	9.6	32.75	9.2	17	20/20	12	15	—	—	—		
	CC15Y	1	14.4	49.13	13.9	23	25/25	18	20	—	—	—		
	CC20Y	1	19.2	65.5	18.5	29	30/30	24	25	—	—	—		
	CC30Y	1	28.8	98.25	27.7	40	40/40	35	35	—	—	—		
B102YM	No Heat	—	—	—	—	24	25/30	—	—	24	25/30	—		
	CC10Y	1	9.6	32.75	9.2	24	30/30	12	15	—	—	—		
	CC15Y	1	14.4	49.13	13.9	28	30/30	18	20	—	—	—		
	CC20Y	1	19.2	65.5	18.5	34	35/35	24	25	—	—	—		
	CC30Y	1	28.8	98.25	27.7	45	45/45	35	35	—	—	—		
B120YM	No Heat	—	—	—	—	24	25/30	—	—	24	25/30	—		
	CC10Y	1	9.6	32.75	9.2	24	30/30	12	15	—	—	—		
	CC15Y	1	14.4	49.13	13.9	28	30/30	18	20	—	—	—		
	CC20Y	1	19.2	65.5	18.5	34	35/35	24	25	—	—	—		
	CC30Y	1	28.8	98.25	27.7	45	45/45	35	35	—	—	—		
B151YM	No Heat	—	—	—	—	28	30/35	—	—	28	30/35	—		
	CC10Y	1	9.6	32.75	9.2	28	30/35	12	15	—	—	—		
	CC15Y	1	14.4	49.13	13.9	28	30/35	18	20	—	—	—		
	CC20Y	1	19.2	65.5	18.5	34	35/35	24	25	—	—	—		
	CC30Y	1	28.8	98.25	27.7	45	45/45	35	35	—	—	—		
	CC40Y	1	38.4	131	37	57	60/60	47	50	—	—	—		
	CC50Y	1	48	163.75	46.2	68	70/70	58	60	—	—	—		

\*= For Canadian use only. Uses "Pr" fuses for inductive circuit.  
 += Field installed only.

## PACKAGE AIR CONDITIONER

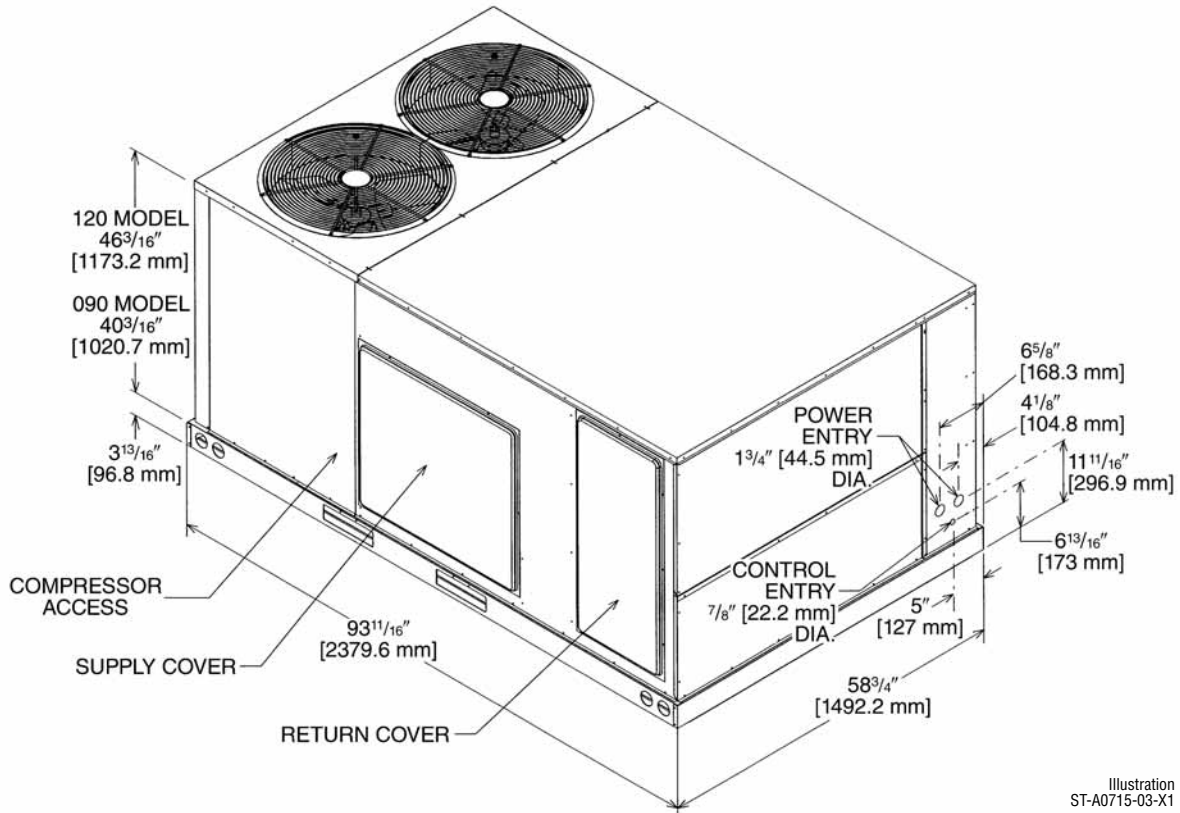
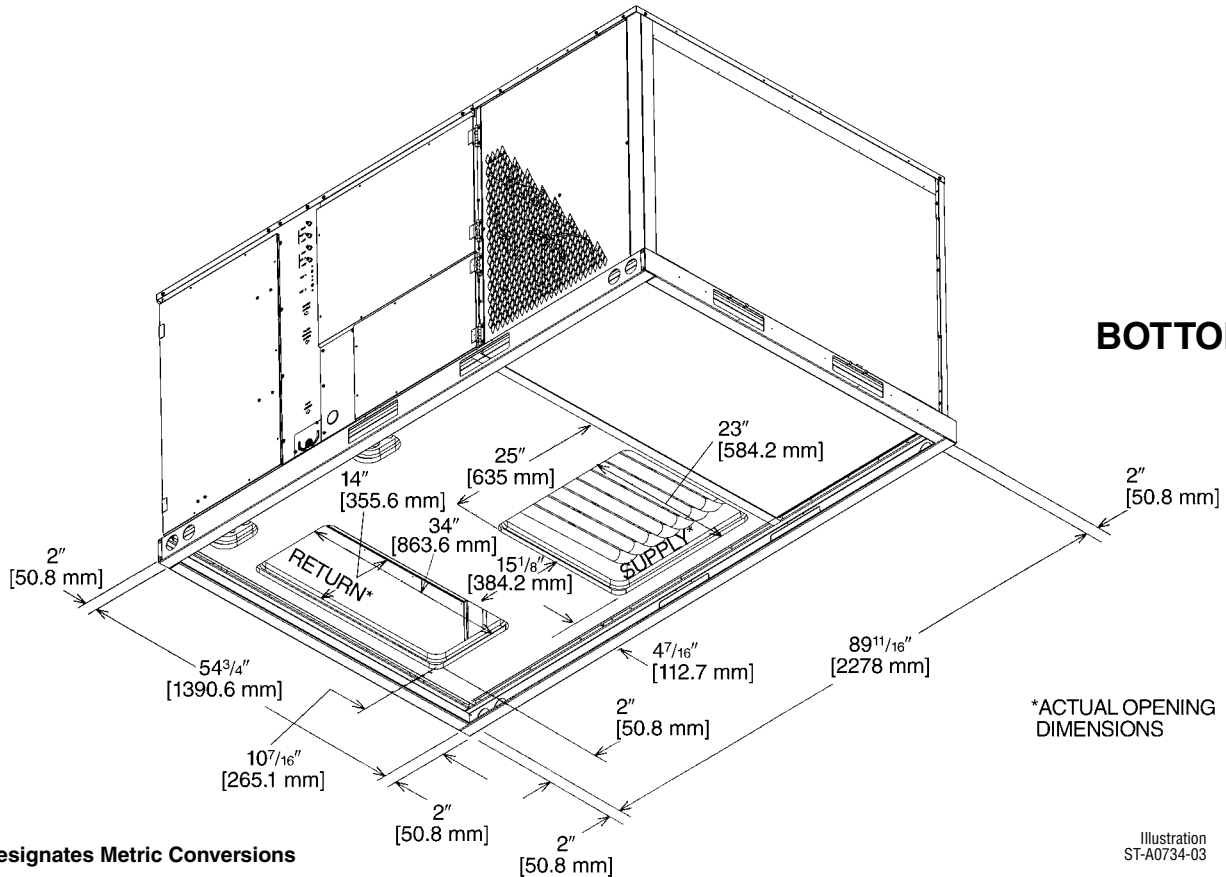

Illustration  
ST-A0715-03-X1



[ ] Designates Metric Conversions

Illustration  
ST-A0734-03

## PACKAGE AIR CONDITIONER

### SUPPLY AND RETURN DIMENSIONS FOR HORIZONTAL APPLICATIONS

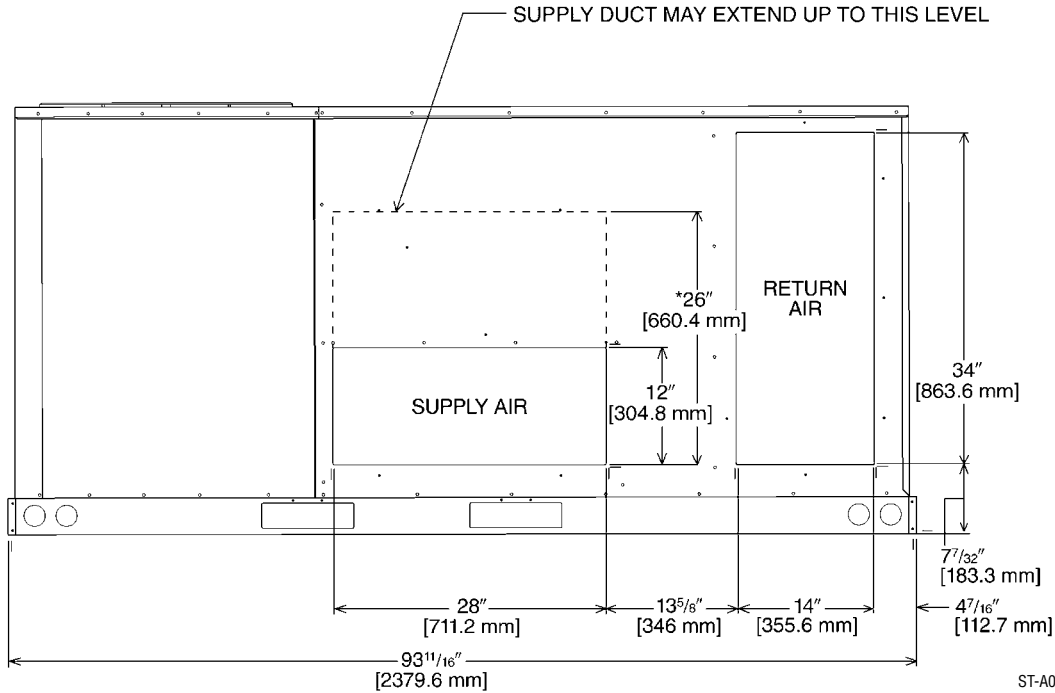

\*RECOMMENDED DUCT DIMENSIONS ARE 26"

### SUPPLY AND RETURN DIMENSIONS FOR DOWNFLOW APPLICATIONS

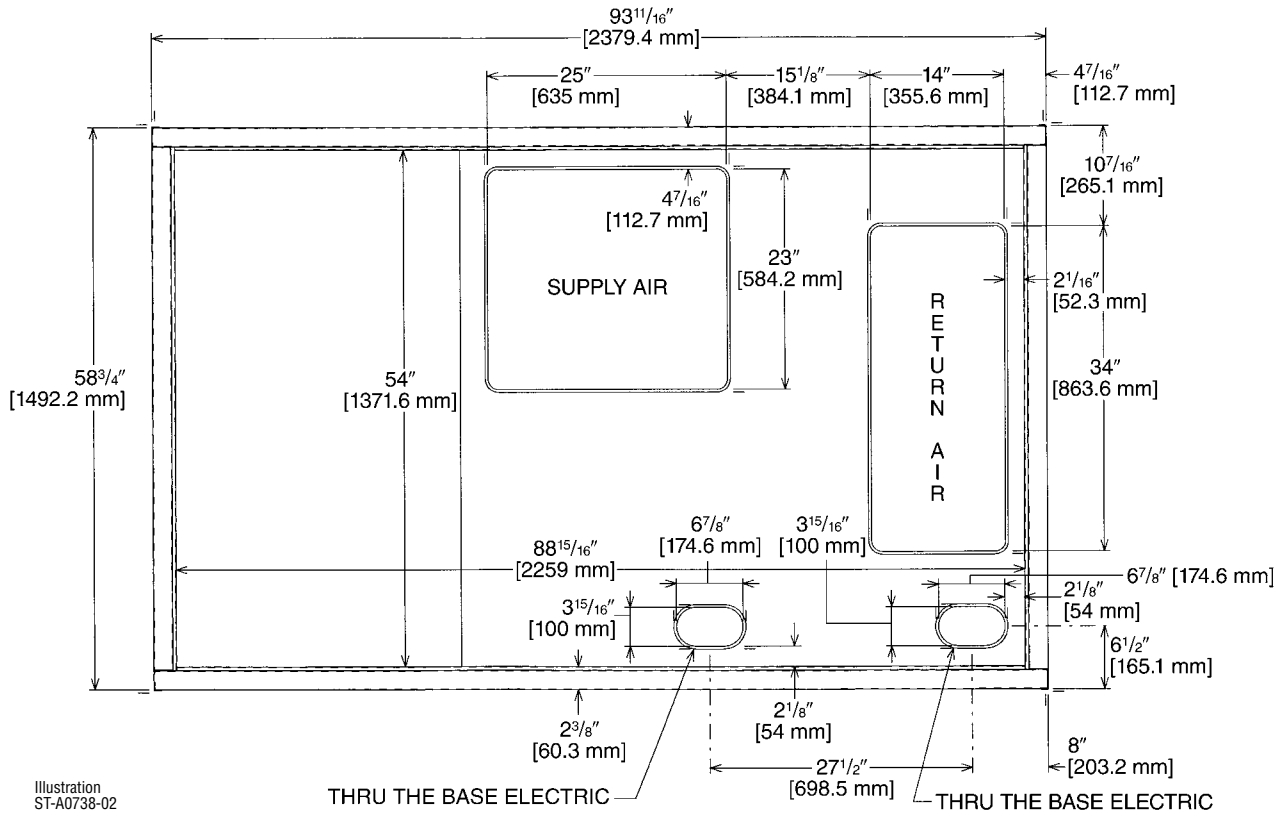

[ ] Designates Metric Conversions

## PACKAGE AIR CONDITIONER

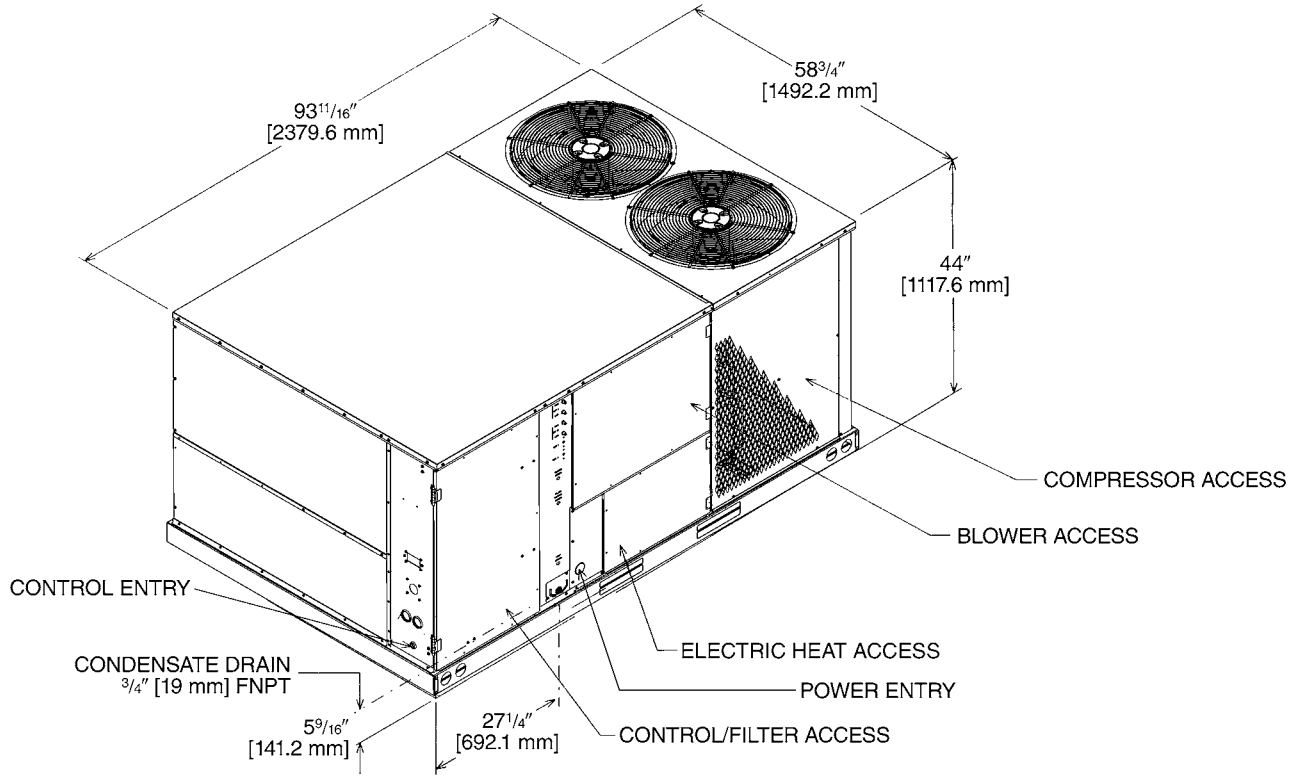

[ ] Designates Metric Conversions

## WEIGHTS

Accessory	Shipping—lbs [kg]	Operating—lbs [kg]
Economizer	90 [40.82]	81 [36.70]
Power Exhaust	44 [19.96]	42 [19.05]
Fresh Air Damper (Manual)	26 [11.79]	21 [9.53]
Fresh Air Damper (Motorized)	43 [19.50]	38 [17.24]
Roof Curb 14"	90 [40.82]	85 [38.60]
Roof Curb 24"	140 [63.50]	135 [61.23]

Capacity Tons [kW]	Corner Weights by Percentage			
	A	B	C	D
6-12.5 [21.1-44.0]	33%	27%	17%	23%

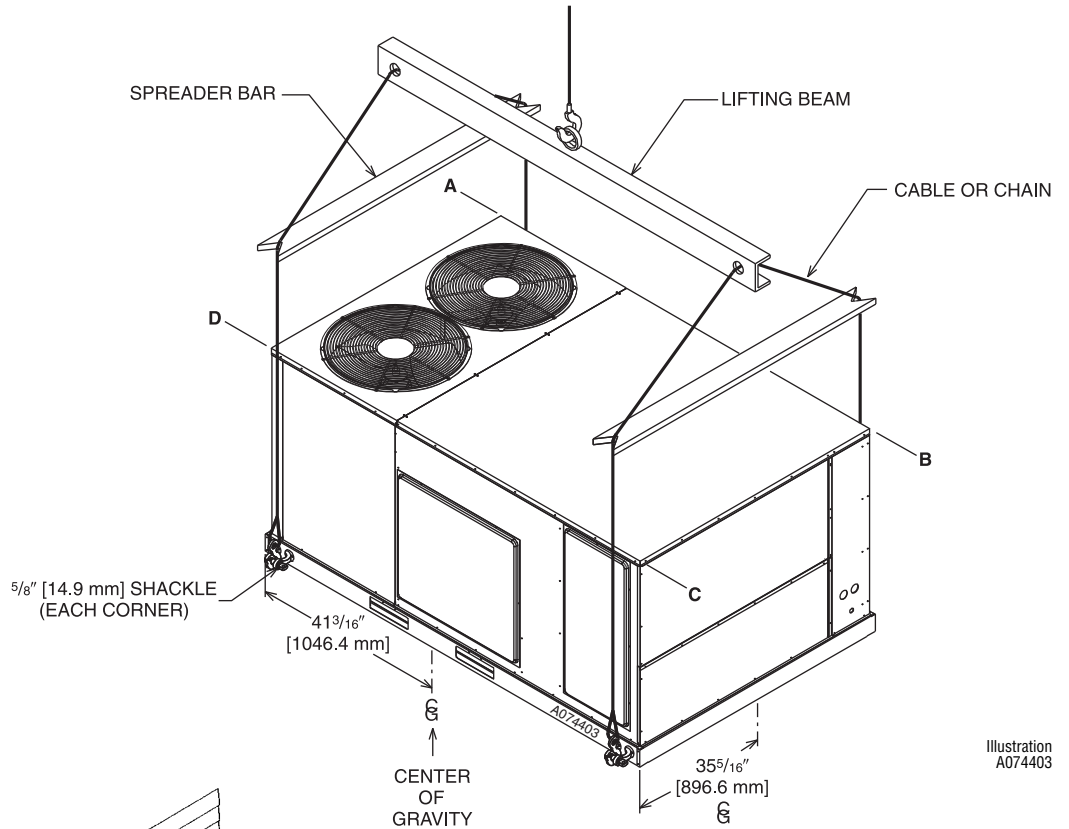
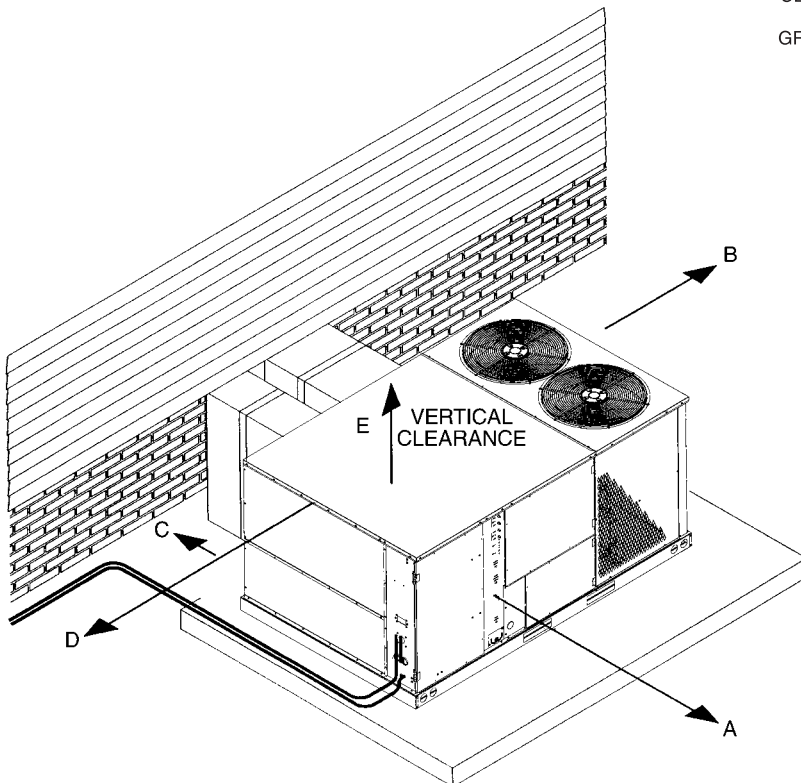

Illustration A074403



## CLEARANCES

The following minimum clearances must be observed for proper unit performance and serviceability.

Recommended Clearance In. [mm]	Location
48 [1219]	A - Front
18 [457]	B - Condenser Coil
18 [457]	C - Duct Side
18 [457]	*D - Evaporator End
60 [1524]	E - Above
*Without Economizer. 48" [1219 mm] With Economizer	

[ ] Designates Metric Conversions

**FIELD INSTALLED ACCESSORY EQUIPMENT**

Accessory	Model Number	Shipping Weight Lbs. [kg]	Installed Weight Lbs. [kg]	Factory Installation Available?
Thermostats	See Thermostat Specification Sheet for Details (T22-001)			No
Electric Heaters*—Canadian Use Only.	RXJJ-CC10 (C,D,Y)	46 [20.9]	36 [16.3]	Yes
	RXJJ-CC15 (C,D,Y)	46 [20.9]	36 [16.3]	Yes
	RXJJ-CC20 (C,D,Y)	46 [20.9]	36 [16.3]	Yes
	RXJJ-CC30 (C,D,Y)	47 [21.3]	37 [16.8]	Yes
	RXJJ-CC31 (C,D)*	47 [21.3]	37 [16.8]	Yes
	RXJJ-CC40 (C,D,Y)	49 [22.2]	39 [17.7]	Yes
	RXJJ-CC41 (C,D)*	49 [22.2]	39 [17.7]	Yes
	RXJJ-CC50 (C,D,Y)	51 [23.1]	41 [18.6]	Yes
RXJJ-CC51 (C,D)*	51 [23.1]	41 [18.6]	Yes	
Economizer w/Single Enthalpy	AXRD-PDCM3	90 [40.8]	81 [36.7]	Yes
Economizer w/Single Enthalpy and Smoke Dectector	AXRD-SDCM3	91 [41.3]	82 [37.2]	Yes
Dual Enthalpy Kit	RXR- AV02	1 [0.5]	1 [0.5]	No
Horizontal Economizer w/Single Enthalpy	AXRD-RDCM3	94 [42.6]	89 [40.4]	No
Carbon Dioxide Sensor	RXR- AR02	3 [1.4]	2 [1.0]	No
Power Exhaust	RXR- BFF02 (C,D,Y)	43 [19.5]	38 [17.2]	No
Manual Fresh Air (Left Panel Mounted)	AXRF-KDA1	38 [17.2]	31 [14.0]	No
Manual Fresh Air (Return Panel)	AXRF-JDA1	26 [11.8]	21 [9.5]	No
Motorized Fresh Air (Return Panel)	AXRF-JDB1	43 [19.5]	21 [9.5]	No
Motor Kit for RXRF-KDA1 (Left Panel Mounted)	RXR- AW02	35 [15.19]	27 [17.7]	No
Roofcurb, 14"	RXKG-CAE14	90 [40.8]	85 [38.5]	No
Roofcurb, 24"	RXKG-CAE24	140 [63.5]	135 [61.2]	No
Roofcurb Adapters	RXR- CDCE50	300 [136.1]	290 [131.5]	No
	RXR- CFCE54	325 [147.4]	315 [142.9]	No
	RXR- CFCE56	350 [158.8]	340 [154.2]	No
	RXR- CGCC12	450 [204.1]	410 [186.0]	No
Concentric Diffuser (Step-Down, 18 x 28)	RXRN-AA61	200 [90.7]	185 [83.9]	No
Concentric Diffuser (Step-Down, 18 x 32)	RXRN-AA66	247 [112.0]	227 [103.0]	No
Concentric Diffuser (Flush, 18 x 28)	RXRN-AA71	170 [77.1]	155 [70.3]	No
Concentric Diffuser (Flush, 18 x 32)	RXRN-AA76	176 [79.8]	161 [73.0]	No
Downflow Adapters (Rect. to Round)	RXMC-CD04	15 [6.8]	13 [5.9]	No
Downflow Adapters (Rect. to Rect., 18 x 28)	RXMC-CE05 ①	18 [8.2]	16 [7.3]	No
Downflow Adapters (Rect. to Rect., 18 x 32)	RXMC-CF06 ②	20 [9.1]	18 [8.2]	No
Compressor Time-Delay Relay Kit	RXMD-A04	2 [1.0]	1 [0.5]	No
Low-Ambient Control Kit (1 Per Compressor)	RXRZ-C02	3 [1.4]	2 [1.0]	Yes
Freeze-Stat Kit	RXR- AM01	1 [0.5]	0.5 [0.2]	Yes
Outdoor Coil Louver Kit	AXRX-AAD01C (6-10 Ton)	29 [11.3]	26 [11.8]	Yes
Outdoor Coil Louver Kit	AXRX-AAD02A (12.5 Ton)	29 [11.3]	26 [11.8]	Yes
Unwired Convenience Outlet	RXR- AN01	2 [1.0]	1.5 [0.7]	Yes

NOTES: ① Used with RXRN-AA61 and RXRN-AA71 concentric diffusers.

② Used with RXRN-AA66 and RXRN-AA76 concentric diffusers.

[ ] Designates Metric Conversions

## THERMOSTATS



**100-Series \***  
Non-Programmable



**200-Series \***  
Programmable



**300-Series \***  
Deluxe  
Programmable



**400-Series \***  
Special Applications/  
Programmable

**500-Series \***  
Communicating/  
Programmable

Brand	Unique Model Number Prefix	Descriptor (3 Characters)	Series (3 Characters)	System (2 Characters)	Type (2 Characters)
UHC	-	TST	101	GE	MS
UHC=Ruud		TST=Thermostat	100=Non-Programmable 200=Programmable 300=Deluxe Programmable 400=Special Applications/ Programmable 500=Communicating/ Programmable	GE=Gas/Oil/Electric HP=Heat Pump MD=Modulating Furnace DF=Dual Fuel UN=Universal AC/HP/GE CM=Communicating	SS=Single-Stage MS=Multi-Stage

\* Photos are representative. Actual models may vary.

For detailed thermostat match-up information, see specification sheet form number T22-001.

## ECONOMIZER FOR DOWNFLOW DUCT INSTALLATION

Use to Select Factory Installed Options Only

**AXRD-PDCM3—Single Enthalpy (Outdoor) and AXRD-SDCM3 Single Enthalpy with Smoke Detector**

**RXXR-AV02—Dual Enthalpy Upgrade Kit**

**RXXR-AR02—Optional Wall-Mounted CO<sub>2</sub> Sensor**

- Features **Honeywell** Controls
- Available Factory Installed or Field Accessory
- Gear Driven Direct Drive Actuator
- Fully Modulating (0-100%)
- Low Leakage Dampers
- Slip-In Design for Easy Installation
- Plug-In Polarized 12-pin Electrical Connections
- Pre-Configured—No Field Adjustments Necessary
- Standard Barometric Relief Damper
- Single Enthalpy with Dual Enthalpy Upgrade Kit Available
- CO<sub>2</sub> Input Sensor Available
- Field Assembled Hood Ships with Economizer
- Economizer Ships Complete for Downflow Duct Application.
- Optional Remote Minimum Position Potentiometer (Honeywell #S963B1128) is Available from Prostock.
- Field Installed Power Exhaust Available
- Prewired for Smoke Detector

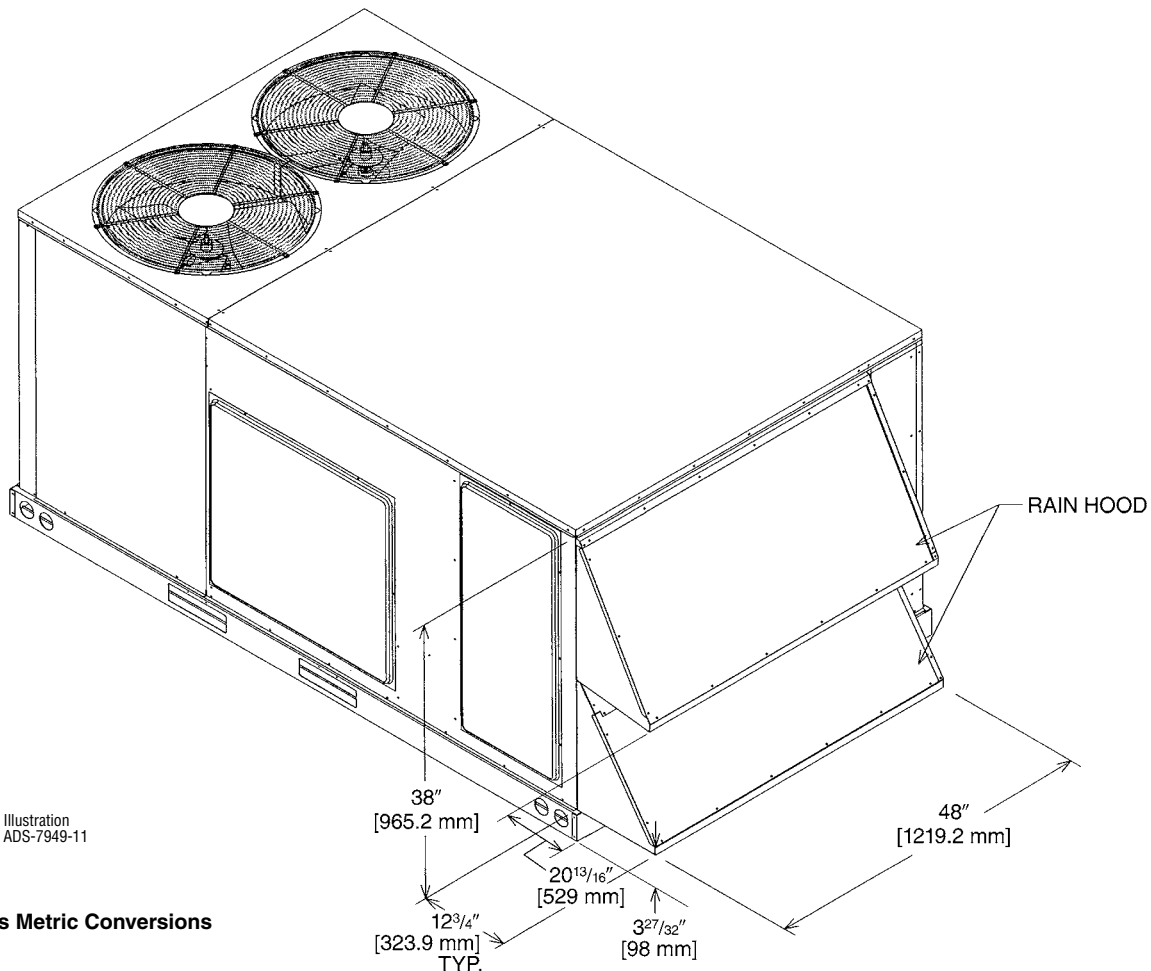
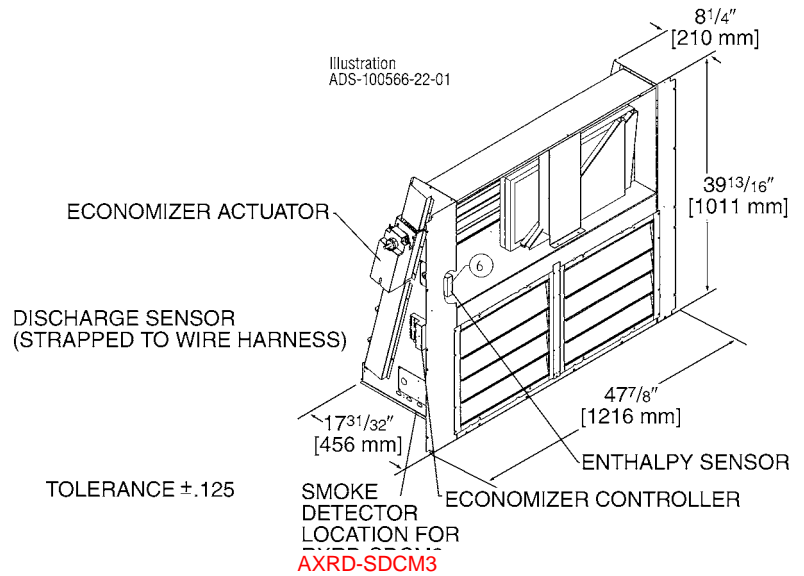

[ ] Designates Metric Conversions

## ECONOMIZER FOR HORIZONTAL DUCT INSTALLATION

### Field Installed Only

**AXRD-RDCM3—Single Enthalpy (Outdoor)**

**RXX-AR02—Dual Enthalpy Upgrade Kit**

**RXX-AR02—Wall-mounted CO<sub>2</sub> Sensor**

- Features **Honeywell** Controls
- Available as a Field Installed Accessory Only
- Gear Driven Direct Drive Actuator
- Fully Modulating (0-100%)
- Low Leakage Dampers
- Slip-In Design for Easy Installation
- Plug-In Polarized 12-pin Electrical Connections
- Pre-Configured—  
No Field Adjustments Necessary
- Standard Barometric Relief Damper
- Single Enthalpy with Dual Enthalpy Upgrade Kit Available
- CO<sub>2</sub> Input Sensor Available
- Field Assembled Hood Ships with Economizer
- Economizer Ships Complete for Horizontal Duct Application
- Optional Remote Minimum Position Potentiometer (Honeywell #S963B1128) is Available from Prostock
- Field Installed Power Exhaust Available

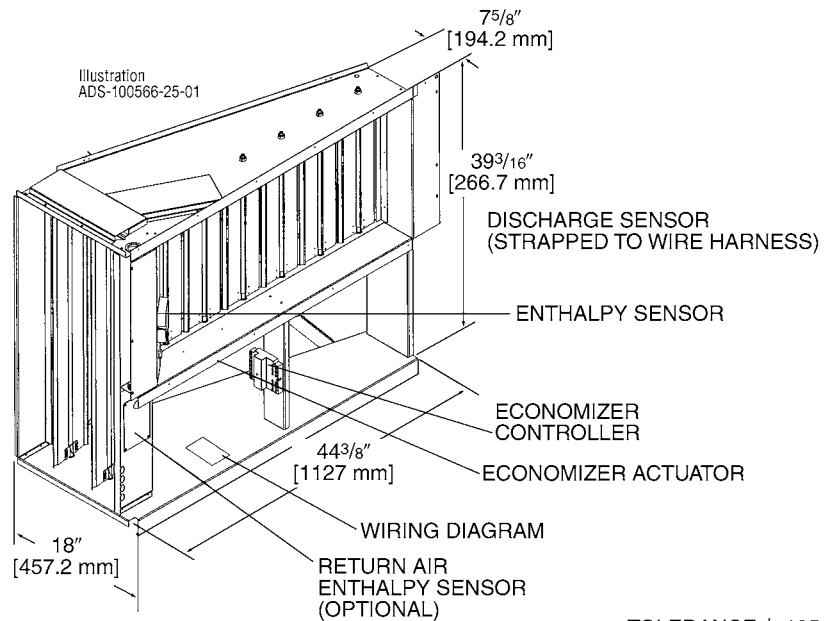

TOLERANCE ± .125

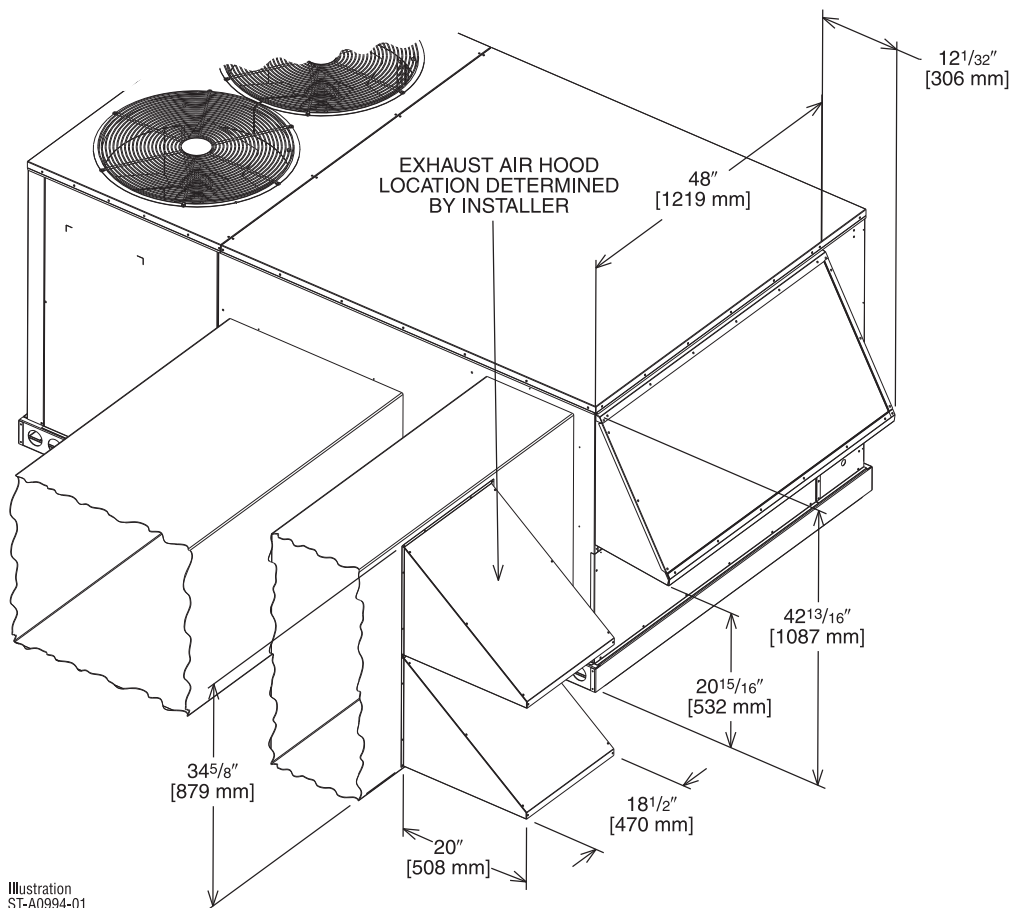

[ ] Designates Metric Conversions

# POWER EXHAUST KIT FOR AXRD-PDCM3(-), AXRD-RDCM3(-), AXRD-SDCM3 ECONOMIZERS

RXRX-BFF02 (C, D, or Y\*)

\*Voltage Code

## VERTICAL AIRFLOW

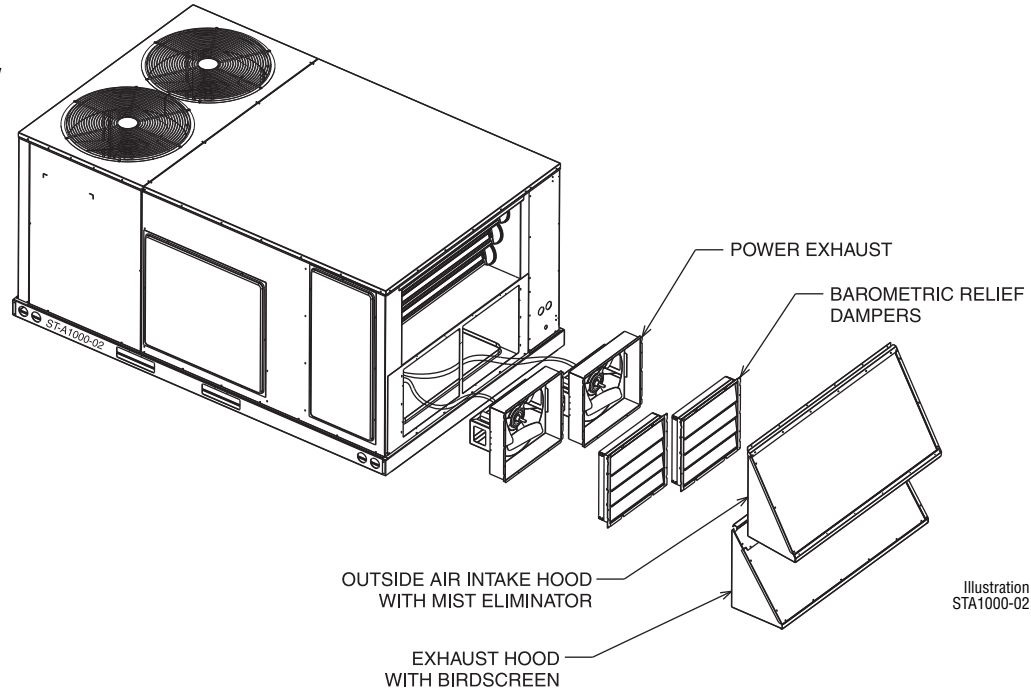

Illustration STA1000-02

## HORIZONTAL AIRFLOW

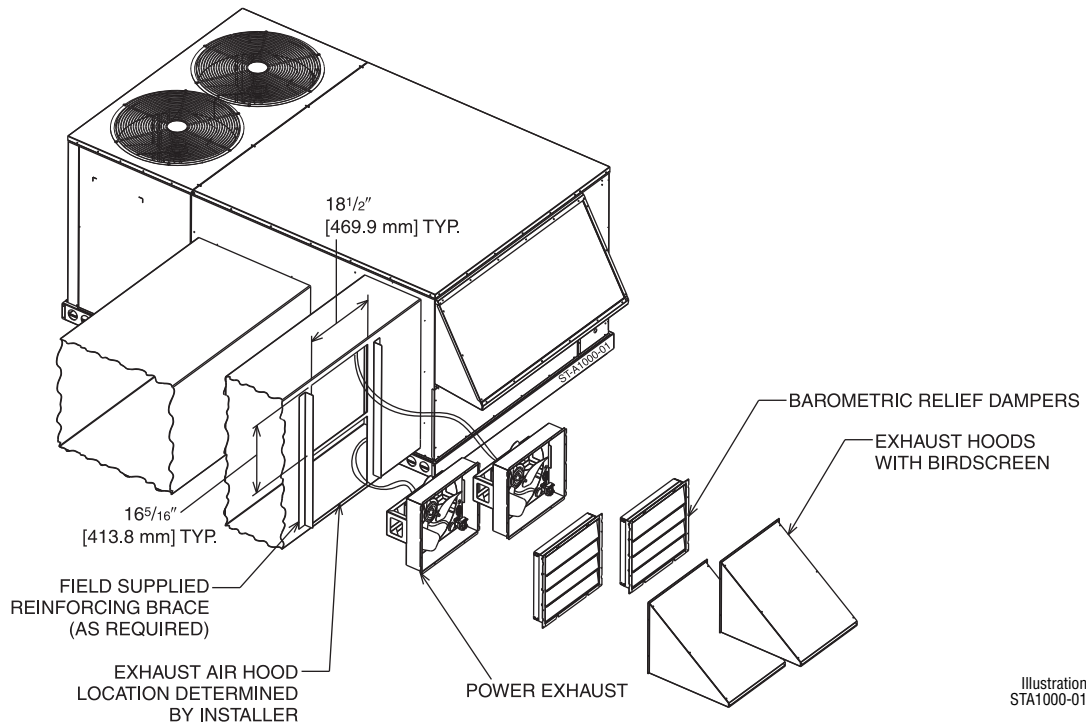

Illustration STA1000-01

Model No.	No. of Fans	Volts	Phase	HP (ea.)	Low Speed		High Speed ①		FLA (ea.)	LRA (ea.)
					CFM [L/s] ②	RPM	CFM [L/s] ②	RPM		
RXRX-BFF02C	2	208-230	1	0.33	2200 [1038]	1518	2500 [1179]	1670	1.48	3.6
RXRX-BFF02D	2	460	1	0.33	2200 [1038]	1518	2500 [1179]	1670	0.75	1.8
RXRX-BFF02Y	2	575	1	0.33	2200 [1038]	1518	2500 [1179]	1670	0.81	1.5

NOTES: ① Power exhaust is factory set on high speed motor tap.

② CFM is per fan at 0" w.c. external static pressure.

**FRESH AIR DAMPER**

**MOTORIZED DAMPER KIT  
RXRX-AW02  
(Motor Kit for AXRF-KDA1)**

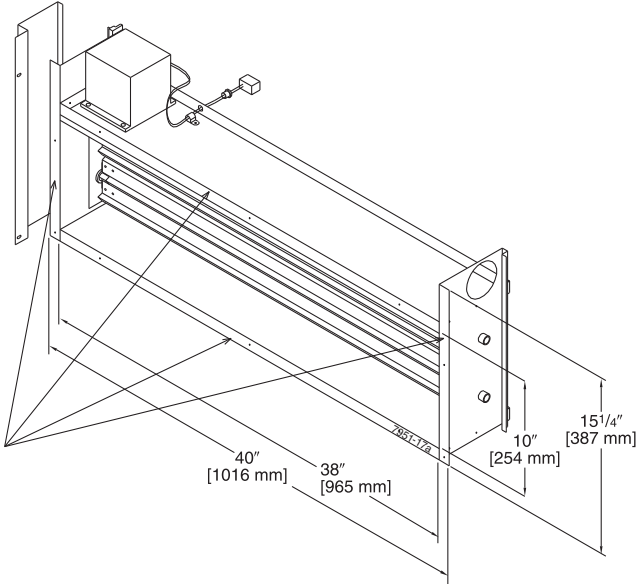

Illustration  
ST-7951-17

[ ] Designates Metric Conversions

**AXRF-KDA1 (Manual)  
DOWNFLOW OR  
HORIZONTAL APPLICATION**

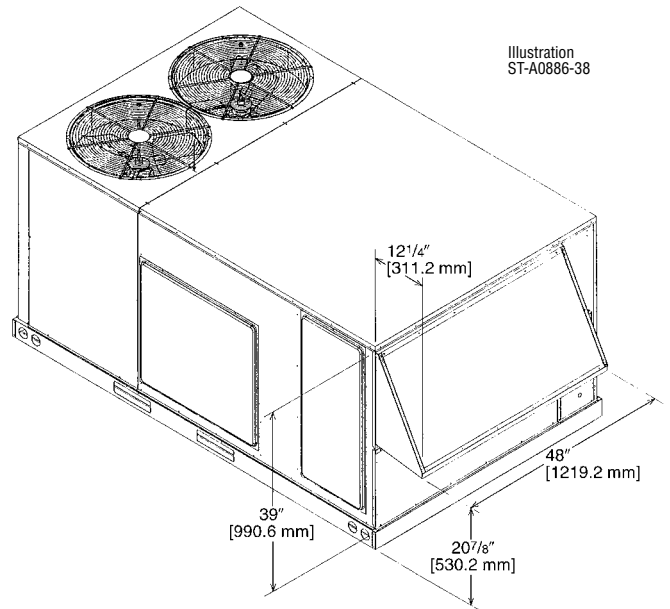

Illustration  
ST-A0886-38

**FRESH AIR DAMPER (Cont.)**

AXRF-JDA1 (Manual)  
 AXRF-JDB1 (Motorized)

**DOWNFLOW APPLICATION**

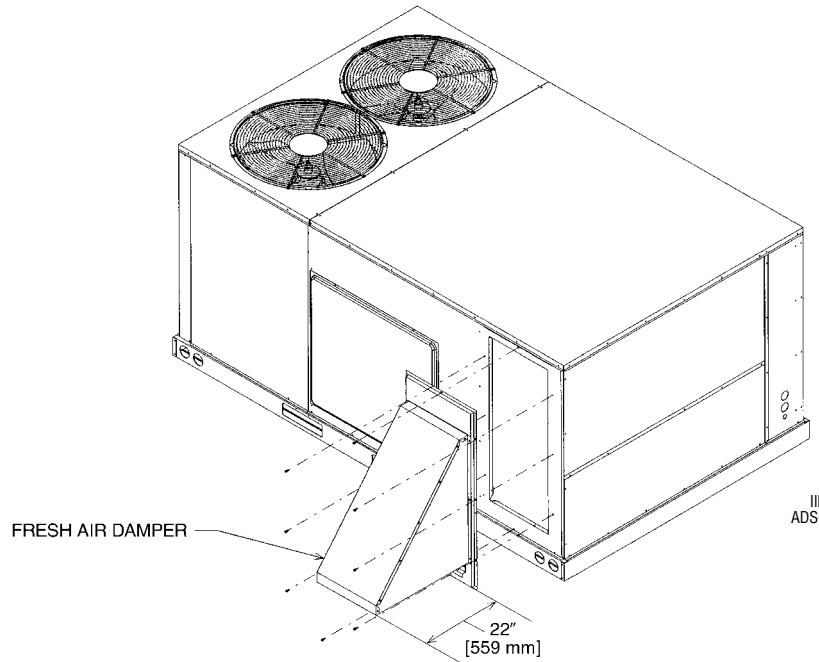
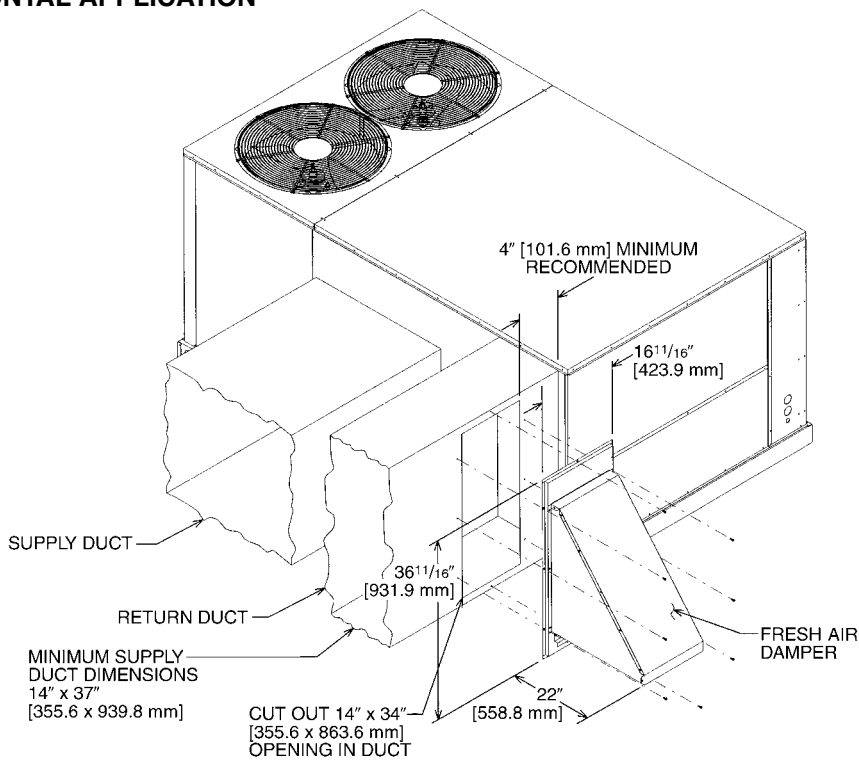

Illustration  
 ADS-7937-58

**HORIZONTAL APPLICATION**

Illustration  
 ST-A0901-01



[ ] Designates Metric Conversions

## ROOFCURBS (Full Perimeter)

- Ruud's roofcurb design can be utilized on all 6-12.5 ton [21.1-44.0 kW] RLNL-B models.
- Two available heights (14" [356 mm] and 24" [610 mm]) for ALL models.
- Quick assembly corners for simple and fast assembly.
- Opening provided in bottom pan to match the "Thru the Curb" electrical connection opening provided on the unit base pan.
- 1" [25 mm] x 4" [102 mm] Nailer provided.
- Insulating panels not required because of insulated outdoor base pan.
- Sealing gasket (40' [12.2 m]) provided with Roofcurb.
- Packaged for easy field assembly.

Roofcurb Model	Height of Curb
RXKG-CAE14	14" [356 mm]
RXKG-CAE24	24" [610 mm]

## TYPICAL INSTALLATION

Illustration ST-A0743-02

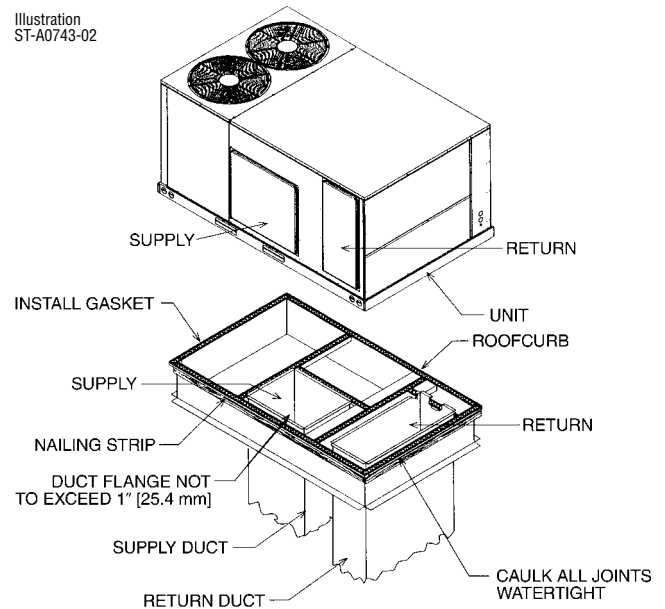

## ROOFCURB INSTALLATION

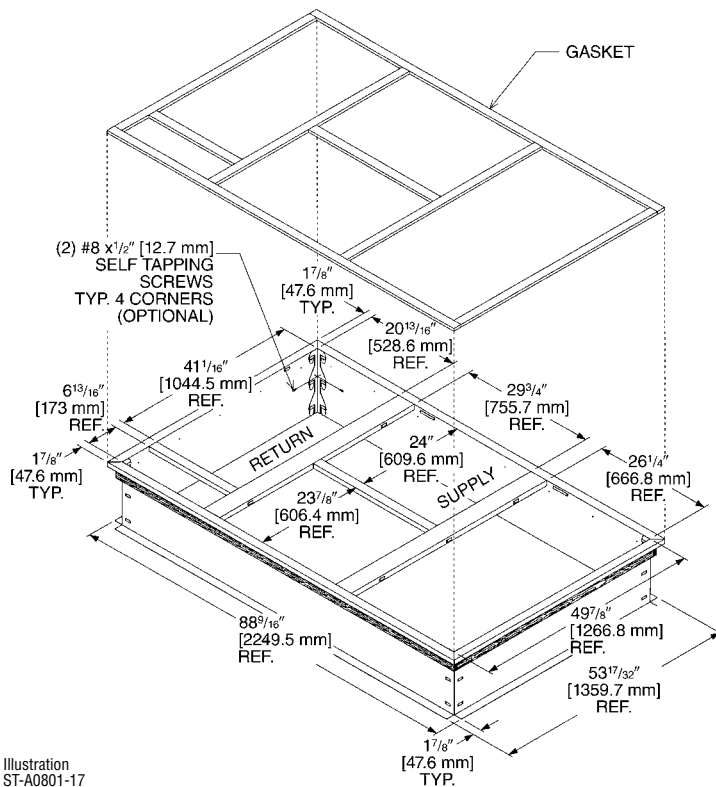
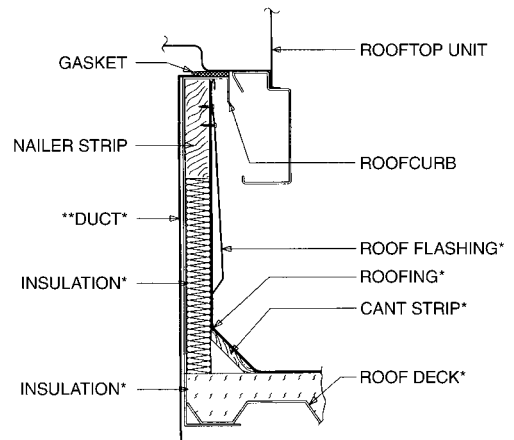

Illustration ST-A0801-17



\*BY CONTRACTOR

\*\*FOR INSTALLATION OF DUCT AS SHOWN, USE RECOMMENDED DUCT SIZES FROM ROOFCURB INSTALLATION INSTRUCTIONS. FOR DUCT FLANGE ATTACHMENT TO UNIT, SEE UNIT INSTALLATION INSTRUCTIONS FOR RECOMMENDED DUCT SIZES.

Illustration ST-A0743-02

[ ] Designates Metric Conversions

**ROOFCURB ADAPTERS**

OLD MODELS	OLD ROOFCURB	ROOFCURB ADAPTER	NEW MODELS (All Share Common Cabinet)
(-)RCF, (-)REF-075/076 (-)RGF-150075, (-)RGF-131076 (-)RGF-201076	RXRK-E50	RXRX-CDCE50	(R)LNL-B073 (R)LNL-B090 (R)LNL-B102 (R)LNL-B120 (R)LNL-B151
(-)RGF-200075 (-)RGG, (-)REG, (-)RCG-075 (-)RGF, (-)REF, (-)RCF-085 (-)RGF, (-)REF, (-)RCF-100 (-)RGG, (-)REG, (-)RCG-100	RXRK-E54	RXRX-CFCE54	
(-)RGF, (-)REF, (-)RCF-125	RXRK-E56	RXRX-CFCE56	
(-)PDC-075 (-)PDC-100/101	RXPK-C12	RXRX-CGCC12	

NOTE: Ductwork modifications may be necessary if the capacity and/or indoor airflow rate of replacement unit is not equivalent to that of the unit being replaced.  
 RLNL-B073, B090, B102, B120, B151 fit on same roofcurb as the RLKB-A090, A102, A120, A150, A181, RLMB- A090, A102, A120, A150, RLNB- A090, A102, A120

## ROOFCURB ADAPTERS (Cont.)

RXRX-CDCE50

Illustration  
ADS-7952-02  
Sheet 2

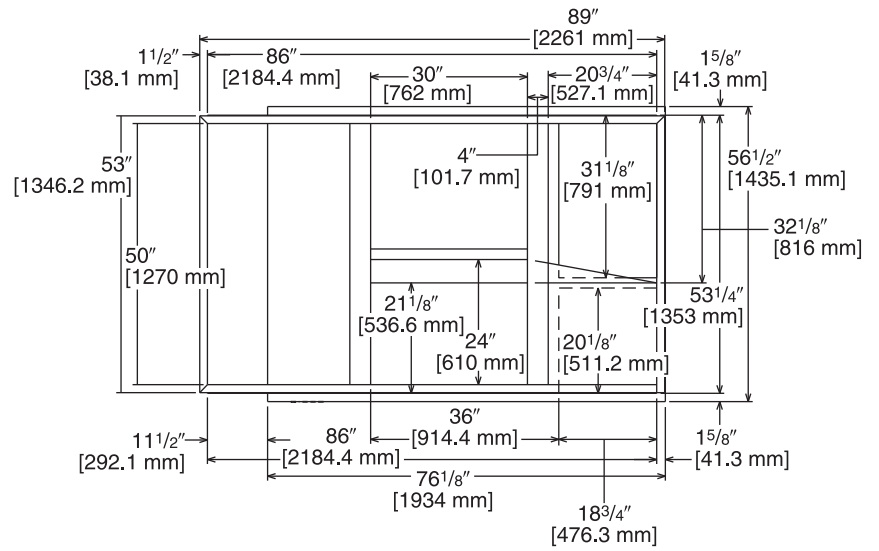

TOP VIEW

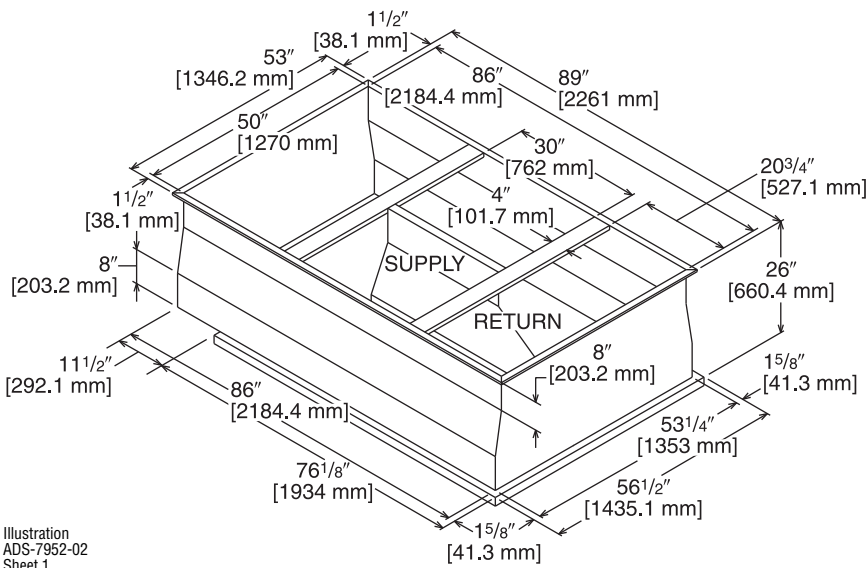

Illustration  
ADS-7952-02  
Sheet 1

[ ] Designates Metric Conversions

**ROOFCURB ADAPTERS (Cont.)**

RXXR-CFCE54

Illustration  
ADS-7952-01  
Sheet 2

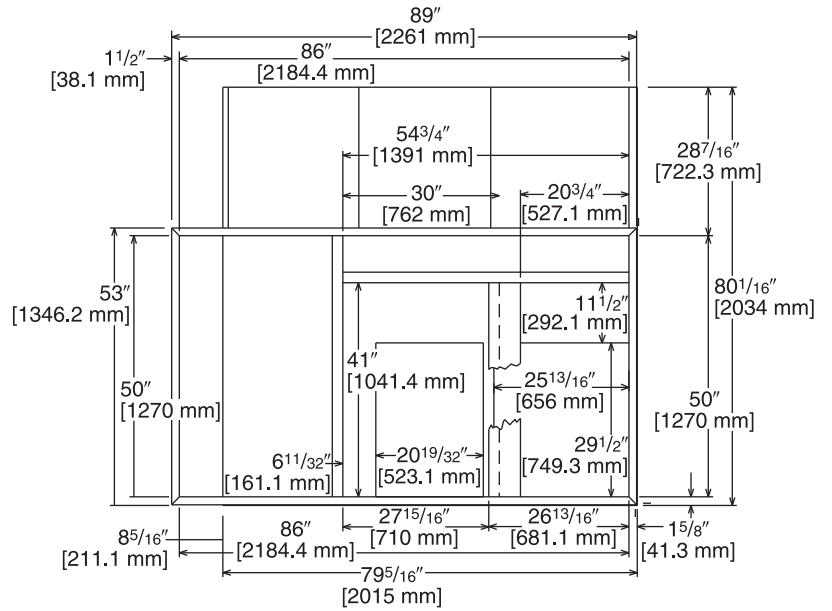

**TOP VIEW**

Illustration  
ADS-7952-01  
Sheet 1

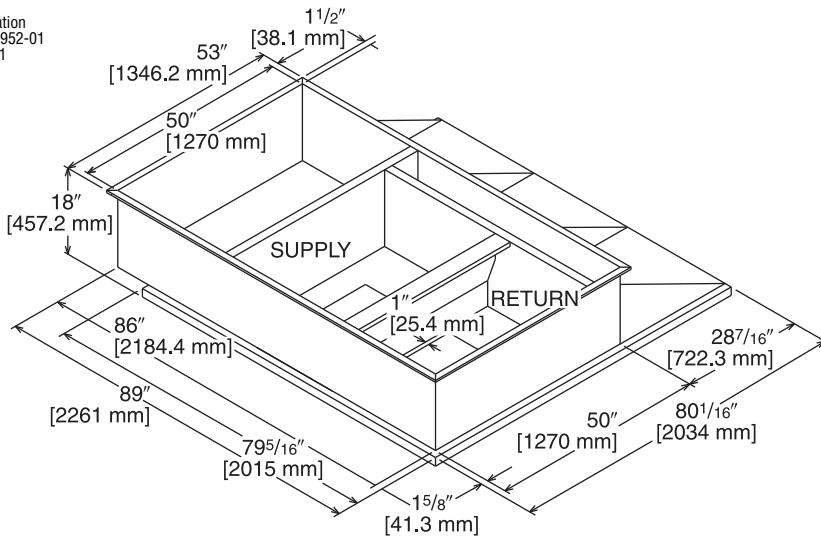

[ ] Designates Metric Conversions

## ROOFCURB ADAPTERS (Cont.)

RXRX-CFCE56

Illustration  
ADS-7952-03  
Sheet 2

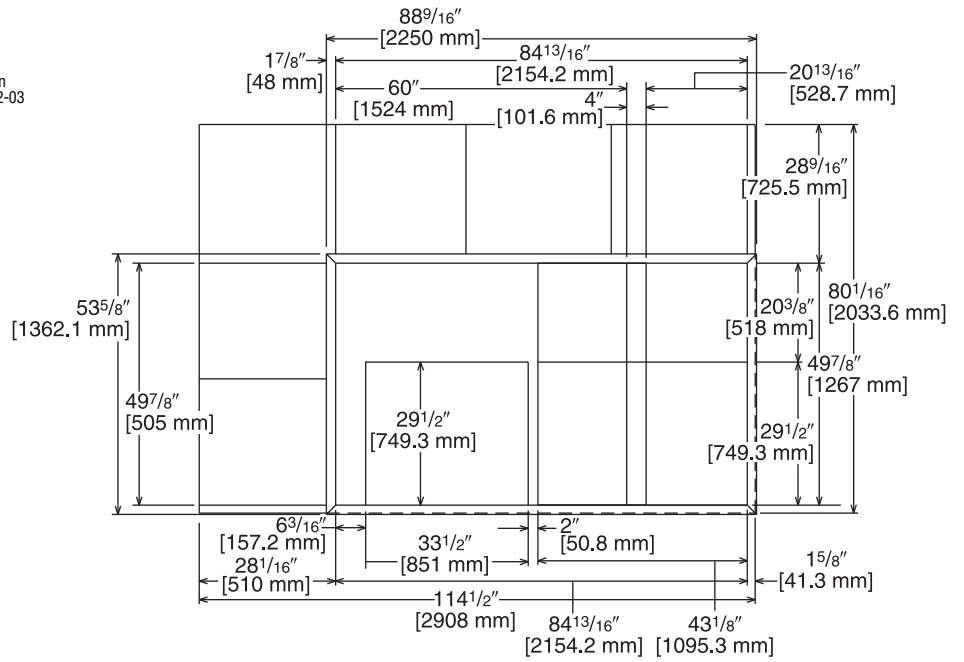

TOP VIEW

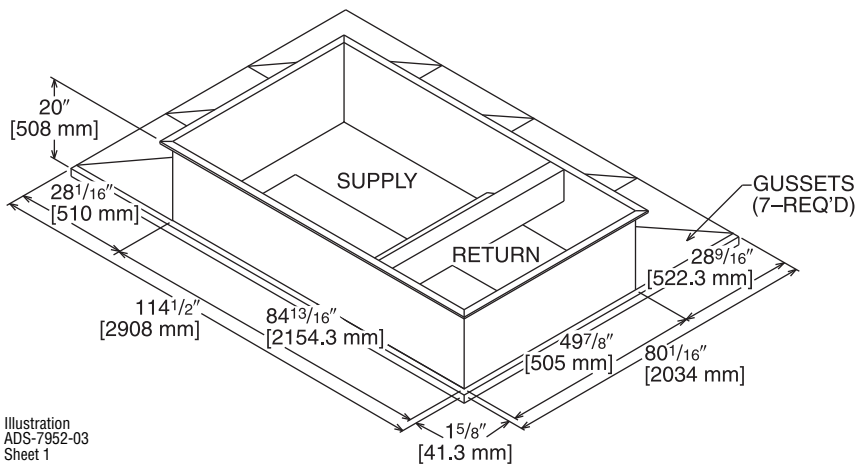

Illustration  
ADS-7952-03  
Sheet 1

[ ] Designates Metric Conversions

## ROOFCURB ADAPTERS (Cont.)

RXRX-CGCC12

Illustration  
ADS-7952-04  
Sheet 2

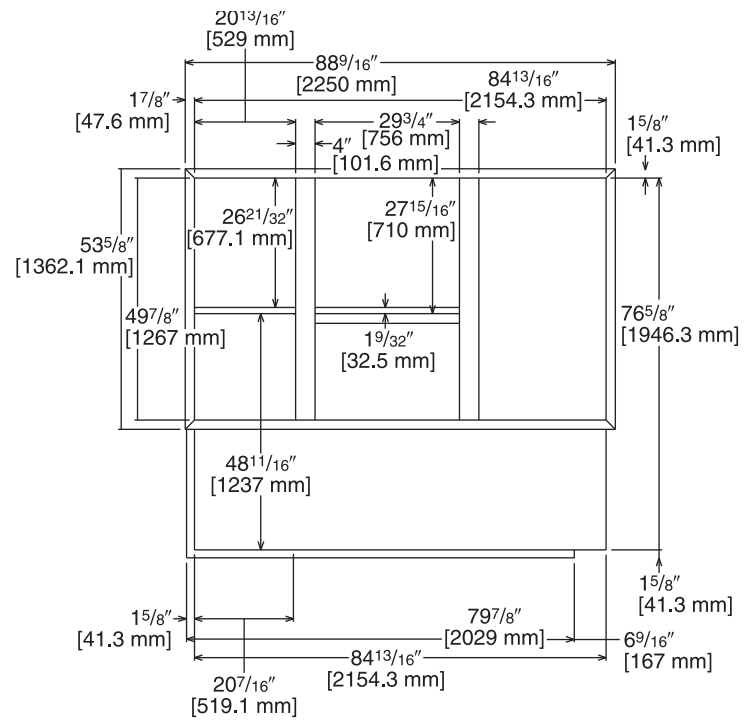

TOP VIEW

Illustration  
ADS-7952-04  
Sheet 1

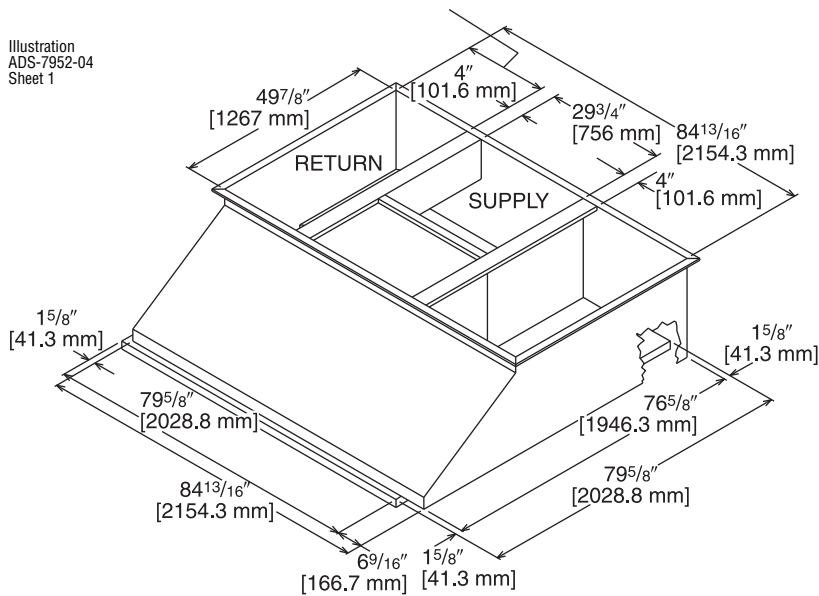

[ ] Designates Metric Conversions

## CONCENTRIC DIFFUSER APPLICATION

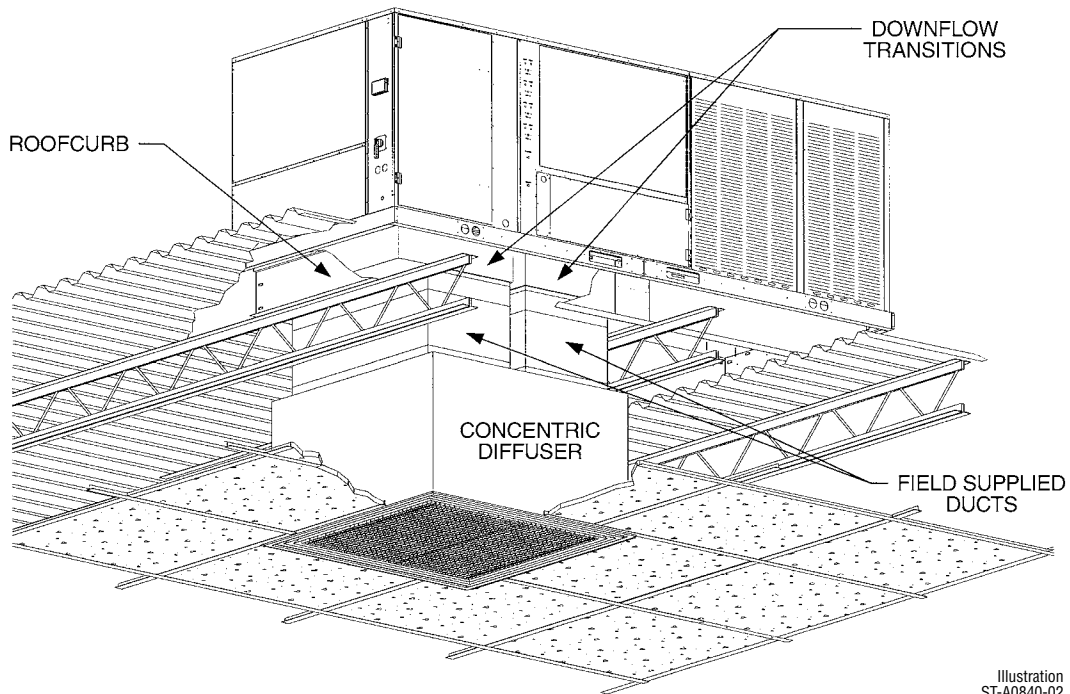

Illustration  
ST-A0840-02

## DOWNFLOW TRANSITION DRAWINGS

### RXMC-CE05

- Used with RXRN-AA61 or RXRN-AA71 Concentric Diffusers.

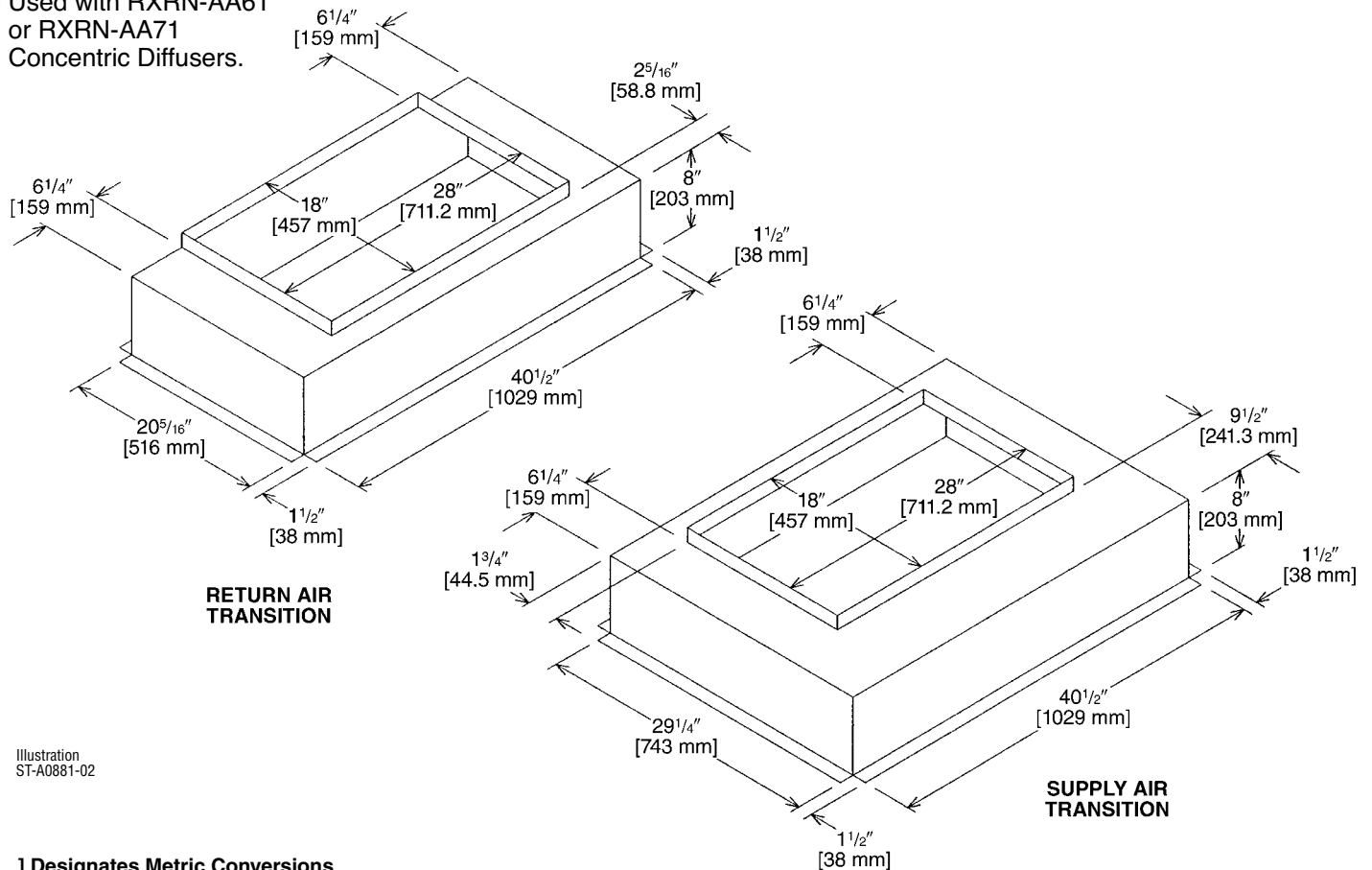

Illustration  
ST-A0881-02

[ ] Designates Metric Conversions

**DOWNFLOW TRANSITION DRAWINGS (Cont.)**

**RXMC-CF06**

- Used with RXRN-AA66  
or RXRN-AA76  
Concentric Diffusers.

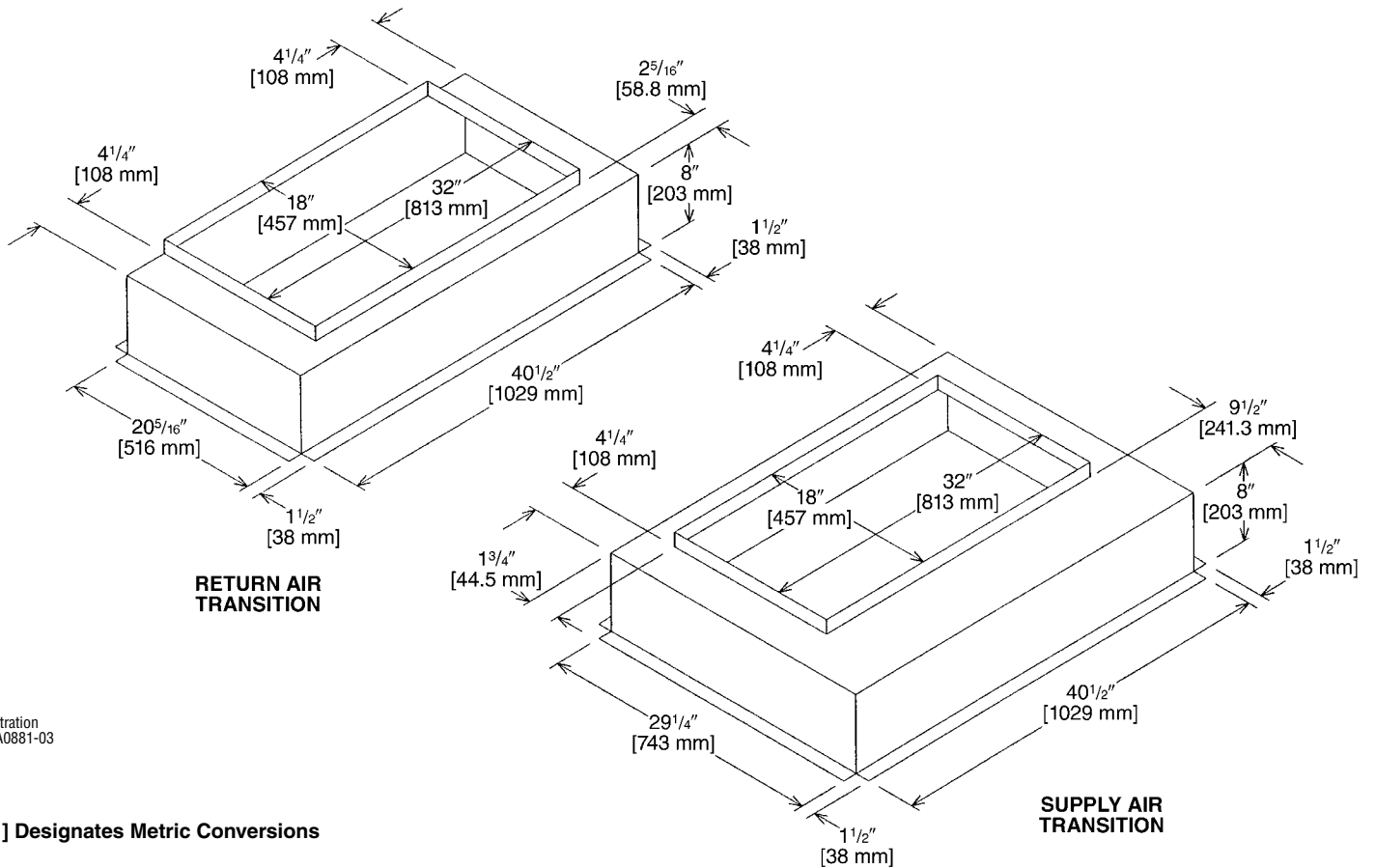

Illustration  
ST-A0881-03

[ ] Designates Metric Conversions

DOWNFLOW TRANSITION DRAWINGS (Cont.)

RXMC-CD04

- Used with RXRN-FA65 or RXRN-FA75 Concentric Diffusers.

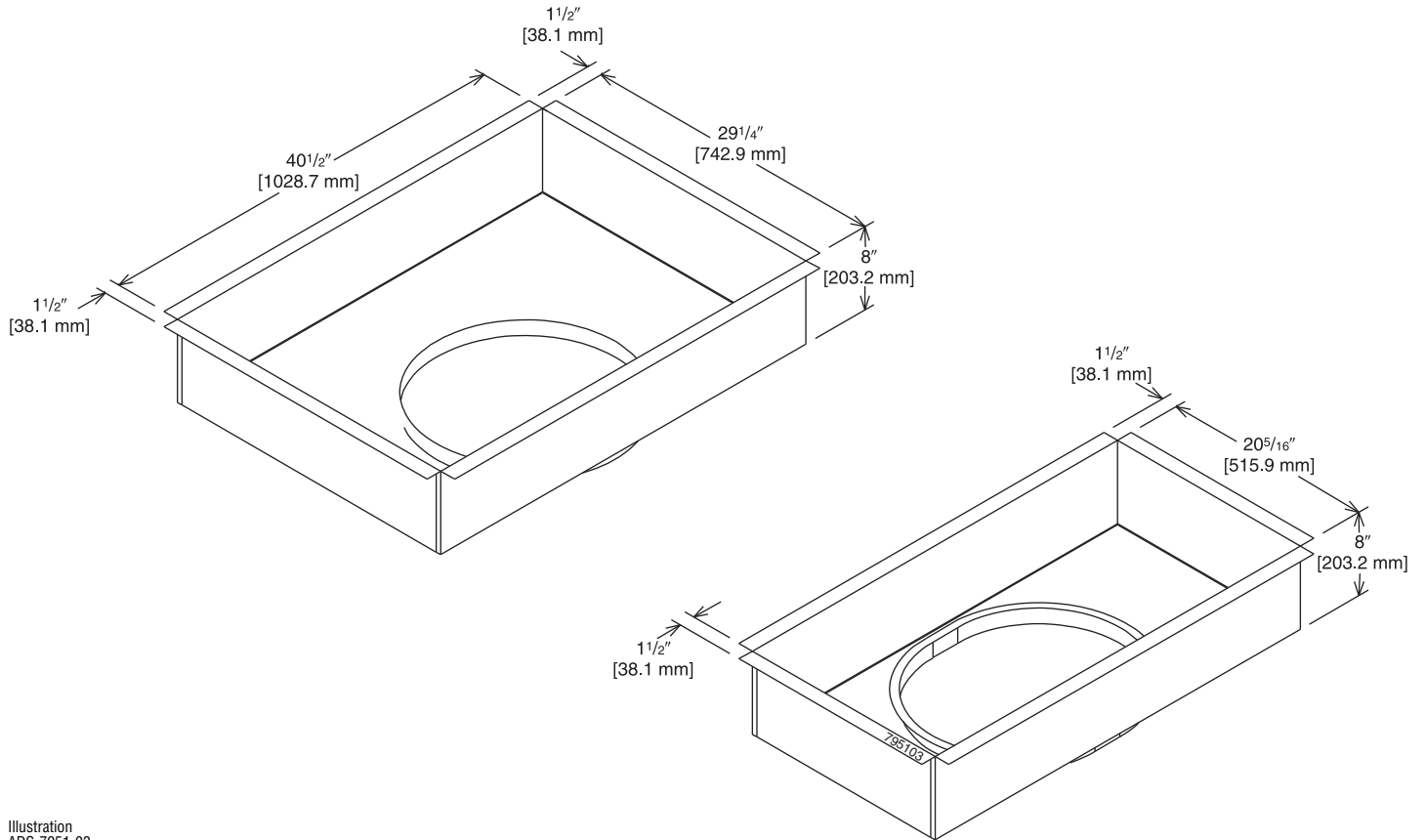

Illustration  
ADS-7951-03

[ ] Designates Metric Conversions

## CONCENTRIC DIFFUSER—STEP DOWN

RXRN-FA65 (7.5 & 8.5 Ton [26.4 & 29.9 kW] Models)

For Use With Downflow Transition (RXMC-CD04)  
and 20" [508 mm] Round Supply and Return Ducts

- All aluminum diffuser with aluminum return air eggcrate.
- Built-in anti-sweat gasket.
- Molded fiberglass supports.
- Built-in hanging supports.
- Diffuser box constructed of sheetmetal insulated with 1" [25.4 mm] 1.5 lbs. [.7 kg] duct liner.

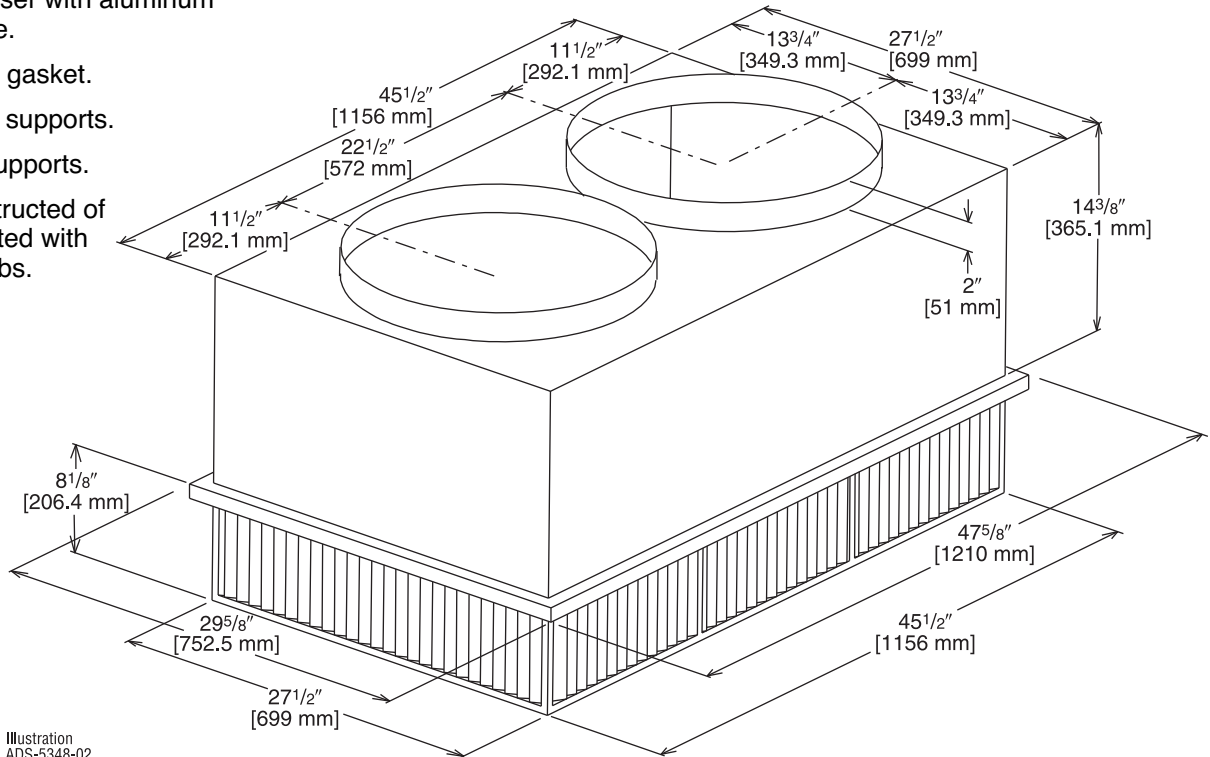

Illustration  
ADS-5348-02

## ENGINEERING DATA<sup>①</sup>

Model No.	Flow Rate CFM [L/s]	Static Pressure in. w.c. [kPa]	Throw <sup>② ③</sup> Feet [m]	Neck Velocity fpm [m/s]	Noise Level <sup>④</sup> (dba)
RXRN-FA65	2600 [1227]	0.17 [0.042]	24-29 [7.3-8.8]	669 [3.4]	20
	2800 [1321]	0.20 [0.050]	25-30 [7.6-9.1]	720 [3.7]	25
	3000 [1416]	0.25 [0.062]	27-33 [8.2-10.1]	772 [3.9]	25
	3200 [1510]	0.31 [0.077]	28-35 [8.5-10.7]	823 [4.2]	25
	3400 [1604]	0.37 [0.092]	30-37 [9.1-11.3]	874 [4.4]	30

NOTES: ① All data is based on the air diffusion council guidelines.

② Throw data is based on 75 FPM Terminal Velocities using isothermal air.

③ Throw is based on diffuser blades being directed in a straight pattern.

④ Actual noise levels may vary due to duct design and do not include transmitted unit noise.  
Adequate duct attenuation must be provided to reduce sound output from the unit.

[ ] Designates Metric Conversions

## CONCENTRIC DIFFUSER—STEP DOWN 18" x 28" [457.2 x 711.2 mm]

RXRN-AA61 (8.5 & 10 Ton [29.9 kW & 35.2] Models)

For Use With Downflow Transition (RXMC-CE05)  
and 18" x 28" [457.2 x 711.2 mm]  
Supply and Return Ducts

- All aluminum diffuser with aluminum return air eggcrate.
- Built-in anti-sweat gasket.
- Molded fiberglass supports.
- Built-in hanging supports.
- Diffuser box constructed of sheetmetal insulated with 1" [25.4 mm] 1.5 lbs. [.7 kg] duct liner.
- Double deflection diffuser with the blades secured by spring steel.

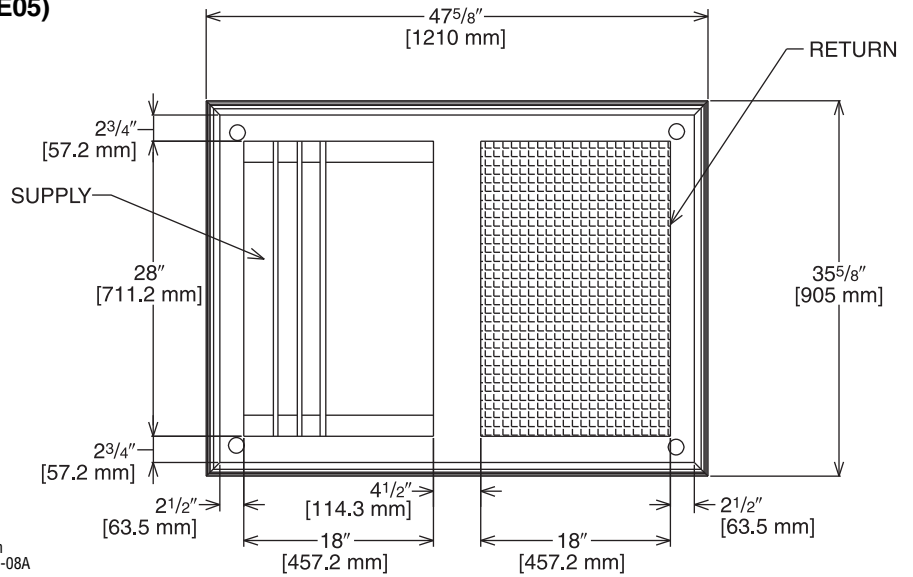

Illustration  
ADS-7951-08A

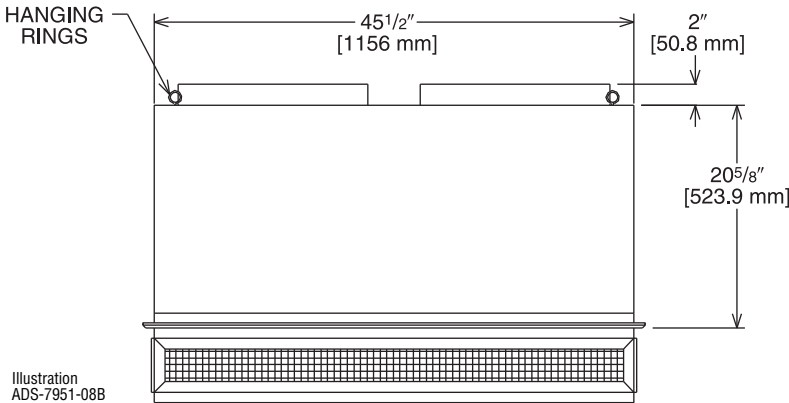

Illustration  
ADS-7951-08B

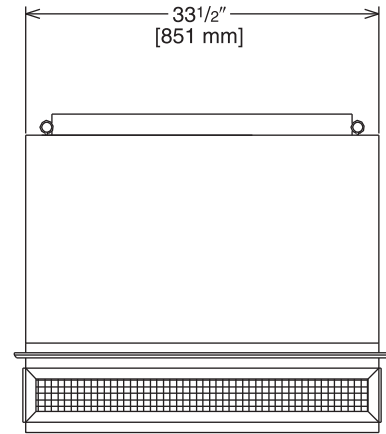

Illustration  
ADS-7951-08C

## ENGINEERING DATA<sup>①</sup>

Model No.	Flow Rate CFM [L/s]	Static Pressure in w.c. [kPa]	Throw <sup>② ③</sup> Feet [m]	Neck Velocity fpm [m/s]	Noise Level <sup>④</sup> (dbA)
RXRN-AA61	3600 [1699]	0.17 [0.042]	25-33 [7.6-10.1]	851 [4.3]	30
	3800 [1793]	0.18 [0.045]	27-35 [8.2-10.7]	898 [4.6]	30
	4000 [1888]	0.21 [0.052]	29-37 [8.8-11.3]	946 [4.8]	30
	4200 [1982]	0.24 [0.060]	32-40 [9.8-12.2]	993 [5.0]	30
	4400 [2076]	0.27 [0.067]	34-42 [10.4-12.8]	1040 [5.3]	30

- NOTES: ① All data is based on the air diffusion council guidelines.  
 ② Throw data is based on 75 FPM Terminal Velocities using isothermal air.  
 ③ Throw is based on diffuser blades being directed in a straight pattern.  
 ④ Actual noise levels may vary due to duct design and do not include transmitted unit noise.  
 Adequate duct attenuation must be provided to reduce sound output from the unit.

[ ] Designates Metric Conversions

## CONCENTRIC DIFFUSER—STEP DOWN 18" x 32" [457.2 x 813 mm]

RXRN-AA66 (12.5 & 15 Ton [44.0 & 52.8 kW] Models)

For Use With Downflow Transition (RXMC-CF06)  
and 18" x 32" [457.2 x 813 mm]  
Supply and Return Ducts

- All aluminum diffuser with aluminum return air eggcrate.
- Built-in anti-sweat gasket.
- Molded fiberglass supports.
- Built-in hanging supports.
- Diffuser box constructed of sheetmetal insulated with 1" [25.4 mm] 1.5 lbs. [.7 kg] duct liner.
- Double deflection diffuser with the blades secured by spring steel.

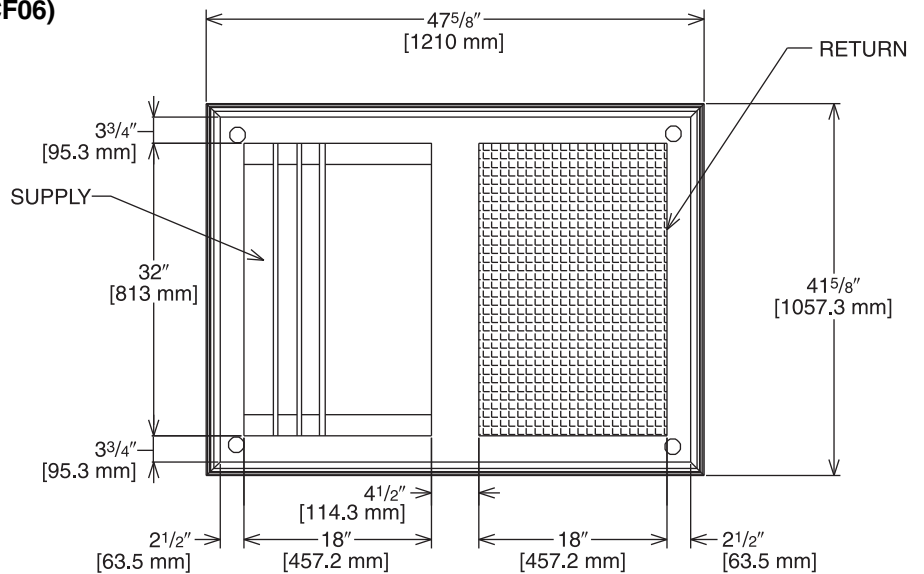

Illustration  
ADS-7951-09A

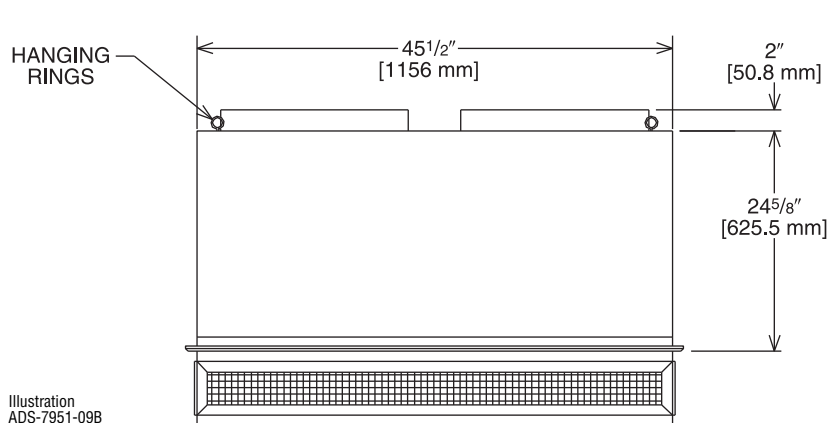

Illustration  
ADS-7951-09B

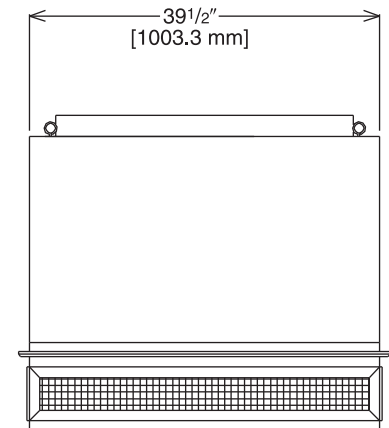

Illustration  
ADS-7951-09C

## ENGINEERING DATA<sup>①</sup>

Model No.	Flow Rate CFM [L/s]	Static Pressure in w.c. [kPa]	Throw <sup>② ③</sup> Feet [m]	Neck Velocity fpm [m/s]	Noise Level <sup>④</sup> (dbA)
RXRN-AA66	4600 [2171]	0.31 [0.077]	26-31 [7.9-9.4]	841 [4.3]	30
	4800 [2265]	0.32 [0.080]	27-32 [8.2-9.8]	878 [4.5]	30
	5000 [2359]	0.34 [0.085]	28-33 [8.5-10.1]	915 [4.6]	30
	5200 [2454]	0.36 [0.090]	28-34 [8.5-10.4]	951 [4.8]	30
	5400 [2548]	0.39 [0.097]	29-35 [8.8-10.7]	988 [6.0]	30

- NOTES: ① All data is based on the air diffusion council guidelines.  
 ② Throw data is based on 75 FPM Terminal Velocities using isothermal air.  
 ③ Throw is based on diffuser blades being directed in a straight pattern.  
 ④ Actual noise levels may vary due to duct design and do not include transmitted unit noise.  
 Adequate duct attenuation must be provided to reduce sound output from the unit.

[ ] Designates Metric Conversions

## FLUSH MOUNT CONCENTRIC DIFFUSER—FLUSH

RXRN-FA75 (7.5 & 8.5 Ton [26.4 & 29.9 kW] Models)

For Use With Downflow Transition (RXMC-CD04) and 20" [508 mm] Round Supply and Return Ducts

- All aluminum diffuser with aluminum return air eggcrate.
- Built-in anti-sweat gasket.
- Molded fiberglass supports.
- Built-in hanging supports.
- Diffuser box constructed of sheetmetal insulated with 1" [25.4 mm] 1.5 lbs. [.7 kg] duct liner.

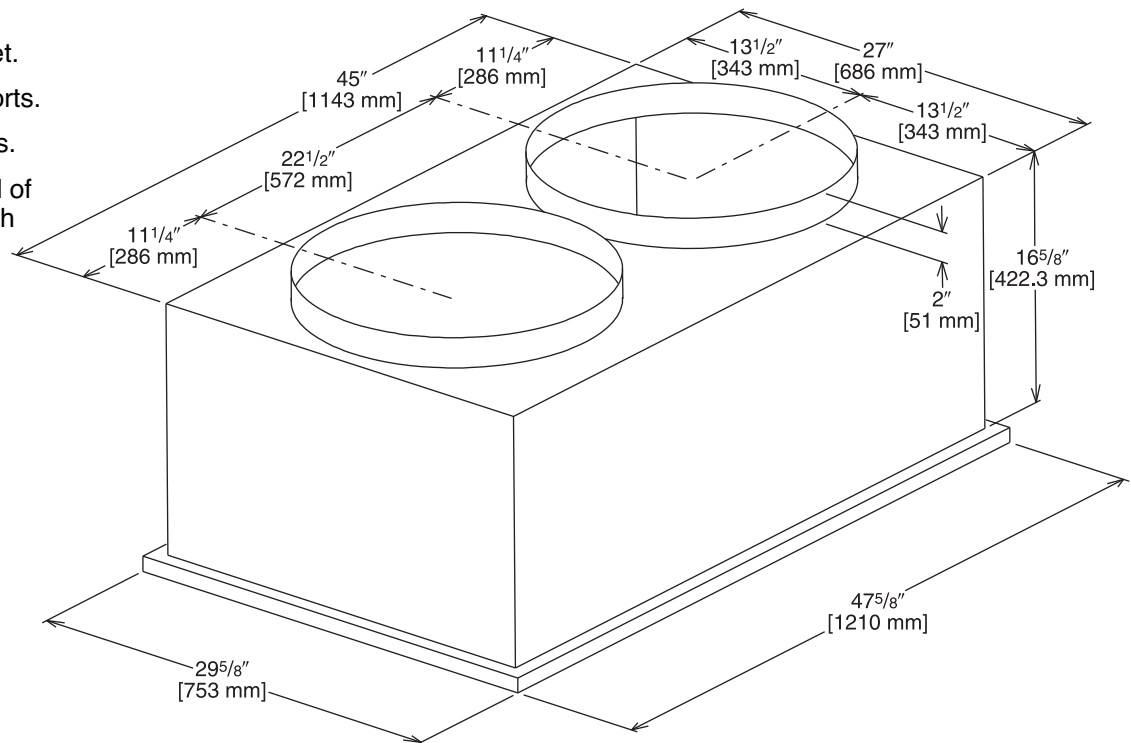

Illustration ADS-5348-04

## ENGINEERING DATA<sup>①</sup>

Model No.	Flow Rate CFM [L/s]	Static Pressure in. w.c. [kPa]	Throw <sup>② ③</sup> Feet [m]	Neck Velocity fpm [m/s]	Noise Level <sup>④</sup> (dbA)
RXRN-FA75	2600 [1227]	.17 [0.042]	19-24 [5.8-7.3]	663 [3.4]	30
	2800 [1321]	.20 [0.050]	20-28 [6.1-8.5]	714 [3.6]	35
	3000 [1416]	.25 [0.062]	21-29 [6.4-8.8]	765 [3.9]	35
	3200 [1510]	.31 [0.077]	22-29 [6.7-8.8]	816 [4.1]	40
	3400 [1604]	.37 [0.092]	22-30 [6.7-9.1]	867 [4.4]	40

- NOTES: ① All data is based on the air diffusion council guidelines.  
 ② Throw data is based on 75 FPM Terminal Velocities using isothermal air.  
 ③ Throw is based on diffuser blades being directed in a straight pattern.  
 ④ Actual noise levels may vary due to duct design and do not include transmitted unit noise. Adequate duct attenuation must be provided to reduce sound output from the unit.

[ ] Designates Metric Conversions

## CONCENTRIC DIFFUSER—FLUSH and 18" x 28" [457.2 x 711.2 mm]

RXRN-AA71 (8.5 & 10 Ton [29.9 & 35.2] Models)

For Use With Downflow Transition (RXMC-CE05)  
and 18" x 28" [457.2 x 711.2 mm]  
Supply and Return Ducts

- All aluminum diffuser with aluminum return air eggcrate.
- Built-in anti-sweat gasket.
- Molded fiberglass supports.
- Built-in hanging supports.
- Diffuser box constructed of sheetmetal insulated with 1" [25.4 mm] 1.5 lbs. [.7 kg] duct liner.

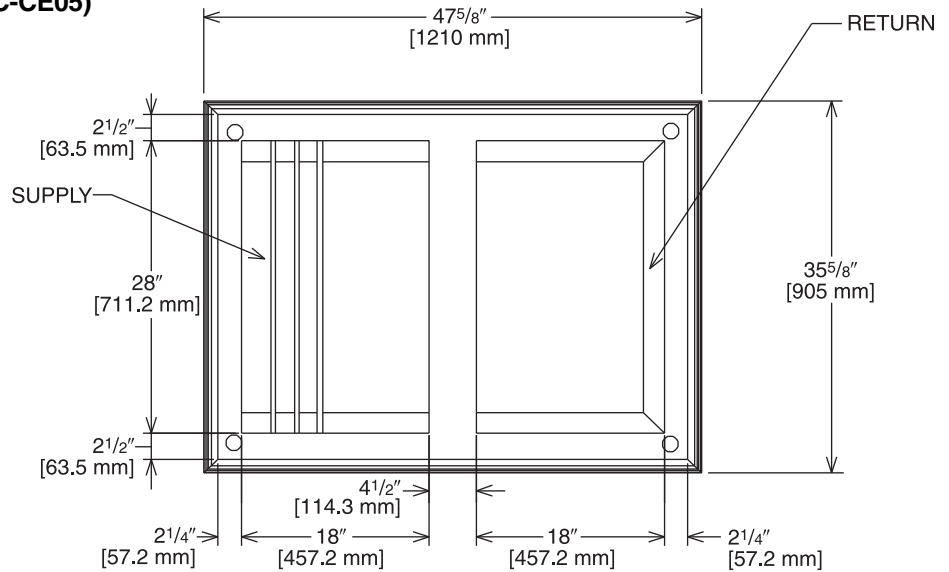

Illustration  
ADS-7951-06A

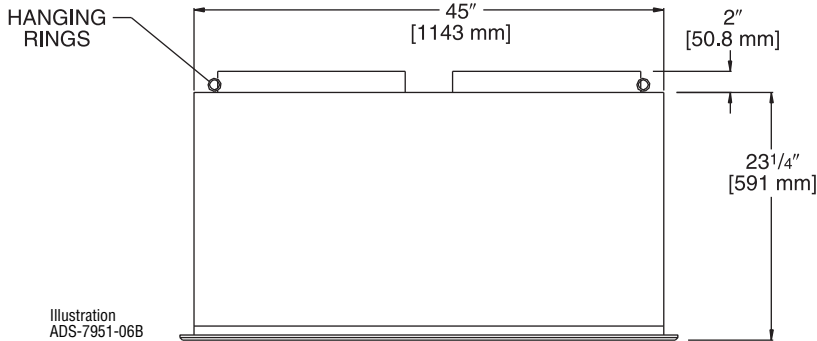

Illustration  
ADS-7951-06B

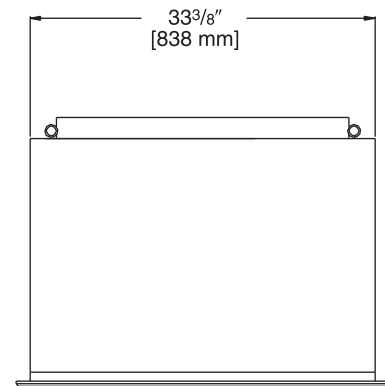

Illustration  
ADS-7951-06C

## ENGINEERING DATA<sup>①</sup>

Model No.	Flow Rate CFM [L/s]	Static Pressure in w.c. [kPa]	Throw <sup>② ③</sup> Feet [m]	Neck Velocity fpm [m/s]	Noise Level <sup>④</sup> (dB)
RXRN-AA71	3600 [1699]	0.17 [0.042]	22-29 [6.7-8.8]	844 [4.3]	35
	3800 [1793]	0.18 [0.045]	22-30 [6.7-9.1]	891 [4.5]	40
	4000 [1888]	0.21 [0.052]	24-33 [7.3-10.1]	938 [4.8]	40
	4200 [1982]	0.24 [0.060]	26-35 [7.9-10.7]	985 [5.0]	40
	4400 [2076]	0.27 [0.067]	28-37 [8.5-11.3]	1032 [5.2]	40

- NOTES: ① All data is based on the air diffusion council guidelines.  
 ② Throw data is based on 75 FPM Terminal Velocities using isothermal air.  
 ③ Throw is based on diffuser blades being directed in a straight pattern.  
 ④ Actual noise levels may vary due to duct design and do not include transmitted unit noise.  
 Adequate duct attenuation must be provided to reduce sound output from the unit.

[ ] Designates Metric Conversions

## CONCENTRIC DIFFUSER—FLUSH 18" x 32" [457.2 x 813 mm]

RXRN-AA76 (12.5 & 15 Ton [44.0 & 52.8 kW] Models)

For Use With Downflow Transition (RXMC-CF06)  
and 18" x 32" [457.2 x 813 mm]

### Supply and Return Ducts

- All aluminum diffuser with aluminum return air eggcrate.
- Built-in anti-sweat gasket.
- Molded fiberglass supports.
- Built-in hanging supports.
- Diffuser box constructed of sheetmetal insulated with 1" [25.4 mm] 1.5 lbs. [.7 kg] duct liner.

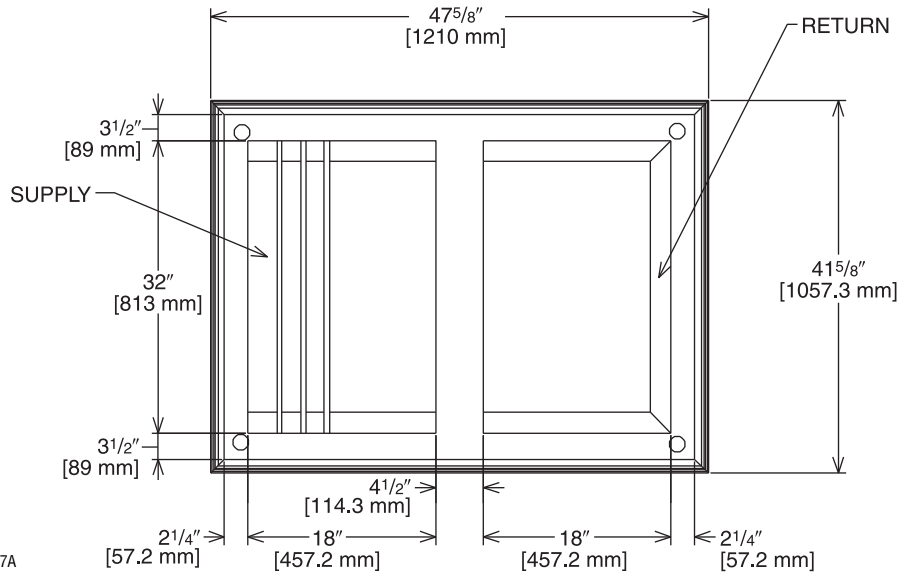

Illustration  
ADS-7951-07A

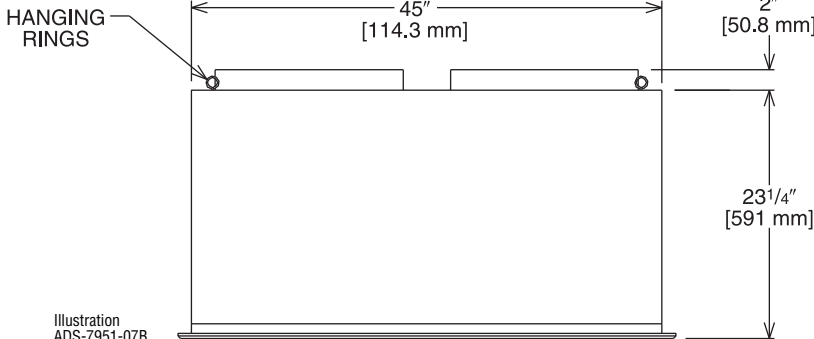

Illustration  
ADS-7951-07B

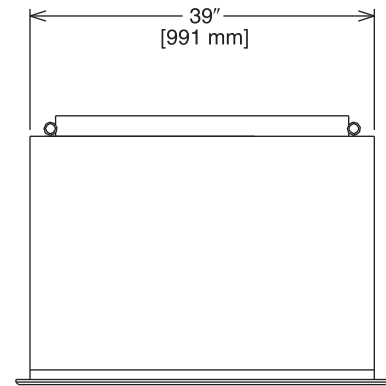

Illustration  
ADS-7951-07C

## ENGINEERING DATA<sup>①</sup>

Model No.	Flow Rate CFM [L/s]	Static Pressure in w.c. [kPa]	Throw <sup>② ③</sup> Feet [m]	Neck Velocity fpm [m/s]	Noise Level <sup>④</sup> (dbA)
RXRN-AA76	4600 [2171]	0.31 [0.077]	25-34 [7.6-10.4]	922 [4.7]	40
	4800 [2265]	0.32 [0.080]	26-35 [7.9-10.7]	962 [4.9]	40
	5000 [2359]	0.34 [0.085]	27-36 [8.2-11.0]	1002 [5.1]	40
	5200 [2454]	0.36 [0.090]	30-39 [9.1-11.9]	1043 [5.3]	45
	5400 [2548]	0.39 [0.097]	32-41 [9.8-12.5]	1083 [5.5]	45

NOTES: ① All data is based on the air diffusion council guidelines.

② Throw data is based on 75 FPM Terminal Velocities using isothermal air.

③ Throw is based on diffuser blades being directed in a straight pattern.

④ Actual noise levels may vary due to duct design and do not include transmitted unit noise.

Adequate duct attenuation must be provided to reduce sound output from the unit.

[ ] Designates Metric Conversions

## General

Units shall be convertible airflow. Operating range for units with electromechanical controls shall be between 125°F (51.7°C) and 50°F (4.4°C). Cooling performance shall be rated in accordance with DOE and/or AHRI testing procedures. All units shall be factory assembled, internally wired, fully charged with R-410A, and 100 percent run-tested before leaving the factory. Wiring internal to the unit shall be colored and numbered for simplified identification. Units shall be UL listed and labeled, classified in accordance to UL 1995/CAN/CSA No. 236-M90 for central cooling air conditioners. Canadian units shall be CUL certified.

## Casing

Unit casing shall be constructed of zinc coated, heavy gauge, galvanized steel. Exterior surfaces shall be cleaned, phosphatized, and finished with a weather-resistant baked enamel finish. Unit's surface shall be tested 1000 hours in a salt spray test in compliance with ASTM B117. Cabinet construction shall allow for all maintenance on one side of the unit. All exposed vertical panels and top covers in the indoor air section shall be insulated with a cleanable foil faced, fire retardant permanent, odorless glass fiber material and secured with adhesive and mechanical fasteners. The base of the unit shall be insulated with foil-faced material. All insulation edges shall be either captured or sealed. The unit's base pan shall have no penetrations within the perimeter of the curb other than the raised 1-1/8" [28.58 mm] high downflow supply return openings to provide an added water integrity precaution. The base rails of the unit shall have provisions for forklift and crane lifting, with forklift capabilities on three sides of the unit.

## Unit Top

The indoor top cover shall be one-piece construction, it shall not be double-hemmed and gasket-sealed.

## Filters

Two inch [50.8 mm], throwaway filters shall be standard on all units.

## Compressors

Units shall have direct-drive, hermetic, scroll type compressors with centrifugal type oil pumps. Motor shall be suction gas-cooled and shall have a voltage utilization range of plus or minus 10 percent of unit nameplate voltage. Internal overloads shall be provided with the scroll compressors. The compressor shall have external isolation to minimize noise.

## Refrigerant Circuits

Each refrigerant circuit shall have TXV (except 073) small orifice refrigerant control expansion device. Service pressure ports, shall be factory-installed as standard.

## Evaporator And Condenser Coils

Internally finned, 3/8" [9.53 mm] copper tubes mechanically bonded to a configured aluminum plate fin shall be standard. Coils shall be leak tested at the factory to ensure pressure integrity. The evaporator coil and condenser coil shall be leak tested to 200 psig and pressure tested to 450 psig. A sloped condensate drain pan shall be standard and shall be removable.

## Outdoor Fans

The outdoor fans shall be direct-drive statically and dynamically balanced, draw-through in the vertical discharge position. The fan motor shall be permanently lubricated and shall have built-in thermal overload protection.

## Indoor Fans

All 3-phase units offer belt drive, FC centrifugal fans with adjustable motor sheaves. All motors shall be thermally protected. All indoor fan motors meet the U.S. Energy Policy Act of 1992 (EPACT).

## Controls

Unit shall be completely factory wired with necessary controls and contactor pressure lugs or terminal block for power wiring. Units shall provide an external location for mounting a fused disconnect device.

24-volt electromechanical control circuit shall include control transformer and contactor pressure lugs for power wiring. Unit shall have single point power entry as standard.

## Accessories/Option

**Roof Curb**—The roof curb shall be designed to mate with the unit's downflow supply and return openings and provide support and a watertight installation when installed properly. The roof curb design shall allow field-fabricated rectangular supply/return ductwork to be connected directly to the curb. Curb design shall comply with NRCA requirements. Curbs shall be shipped knocked down for toolless field assembly and shall include wood nailer strips.

**Economizer**—This accessory shall be either field or factory-installed and is available with barometric relief standard. The assembly includes direct drive gear driver, fully modulating 0-100 percent motor and dampers, minimum position setting, mixed air sensor, wiring harness with plug, and single enthalpy control. Optional differential enthalpy control shall be field-installed. The factory-installed economizer arrives ready for operation.

**Remote Potentiometer**—Field installed, the minimum position setting of economizer shall be adjusted with this accessory.

### Motorized Outside Air Dampers—

Field-installed manually set outdoor air dampers shall provide up to 50 percent outside air. Once set, outdoor air dampers shall open to set position when indoor fan starts. The damper shall close to the full closed position when indoor fan shuts down.

**Manual Outside Air Damper**—Factory or field-installed rain hood and screen shall provide up to 50 percent outside air.

**Oversized Motors**—Factory installed belt drive oversized motors shall be available for high static applications.

**Powered Exhaust**—The field installed powered exhaust, available for all units, shall provide exhaust of return air, when using an economizer, to maintain better building pressurization.

**Through the Base Electrical Access**—An electrical service entrance shall be factory provided allowing electrical access for both control and main power connection inside the curb and through the base of the unit. Option will allow for field installation of liquid-tight conduit and an external field-installed disconnect switch.

**Through the Base Electrical with Disconnect Switch**—Factory-installed 3-pole, molded case disconnect switch with provisions for through the base electrical connections are available. The disconnect switch will be installed in the unit in a water-tight enclosure with access through a hinged door. Factory wiring will be provided from the switch to the unit high voltage terminal block. The switch will be UL/CSA agency recognized. Note: The disconnect switch will be sized per NEC and UL guidelines but will not be used in place of unit over current protection.

**Freeze/Clogged Filter Switches**—This factory or field-installed option allows for individual fan failure or dirty filter protection. If indoor coil gets too cold due to low airflow, compressor operation will be temporarily interrupted.

**Enthalpy Control**—Single Enthalpy Control shall be standard for all economizers. Enthalpy control offers a higher level of comfort control, along with energy savings potential, than the standard dry bulb control. This is due to the additional wet bulb sensing capability.

**High Pressure Cutout**—High pressure cutout shall be standard on all models and 1/4 turn fasteners. All scroll compressors shall include Internal Pressure Relief as standard.

**Hinged Access Doors**—Stainless steel metal hinges and 1/4 turn fasteners are standard on the Filter/Electrical Access Door, Heat Exchanger door and blower doors.

**Thermostats**—Two stage heating and cooling operation shall be available, for field installation, in either manual or automatic changeover. Automatic programmable electronic with night set back shall also be available.

**Differential Enthalpy**—Adds on to the standard single control with other enthalpy sensors that compare total heat content of the indoor air and outdoor air to determine the most efficient air source. This control option offers the highest level of comfort control, plus energy efficiency available.

**Low Ambient Cooling**—Electromechanical models have cooling capabilities to 40°F as built, or to 0°F by adding the optional low ambient (froststat) control.

FLASHES	DIAGNOSIS
1	FAILED TO DETECT OR SUSTAIN FLAME.
2	PRESSURE SWITCH OR INDUCER PROBLEM DETECTED.
3	HIGH LIMIT SWITCH PROTECTION DEVICE OPEN.
4	FLAME SENSED GAS VALVE NOT ENERGIZED OR FLAME SENSED NO "W" SIGNAL.
5	FLAME ROLL OUT SWITCH OPEN.

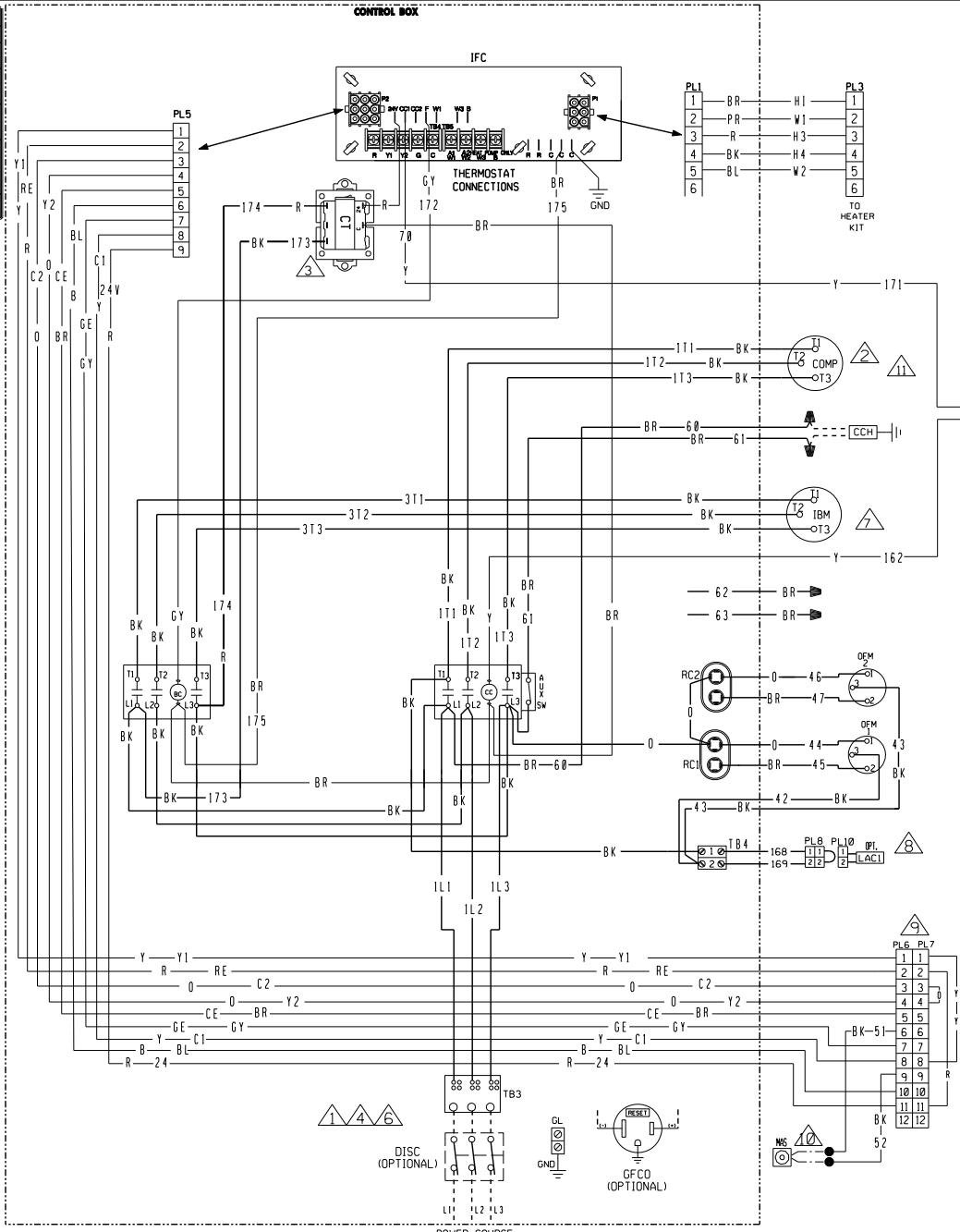

- NOTES.**
- 1. CONNECTORS SUITABLE FOR USE WITH COPPER CONDUCTORS ONLY.
  - 2. COMPRESSOR MOTOR THERMALLY PROTECTED. ALL 3 PHASE MODELS ARE PROTECTED UNDER PRIMARY SINGLE PHASE CONDITIONS.
  - 3. TRANSFORMER FACTORY WIRED FOR 230 VOLTS.
  - 4. CONNECT FIELD WIRE TO FACTORY SUPPLIED POWER BLOCK IN ELECTRICAL BOX.
  - 5. LOW VOLTAGE CIRCUIT IS N.E.C. CLASS 2 WITH A CLASS 2 TRANSFORMER, 24V, 50/60 HZ SUPPLIED.
  - 6. CONNECT FIELD WIRING IN GROUND RAIN TIGHT CONDUIT TO FUSED DISCONNECT.
  - 7. MOTOR FACTORY WIRED FOR CORRECT VOLTAGE.
  - 8. REMOVE PL10 & PL11 FOR LOW AMBIENT ACCESSORY. PL10 & PL11 LOCATED IN BLOWER COMPARTMENT.
  - 9. REMOVE PL7 FOR ECONOMIZER ACCESSORY. PL 6 & PL7 LOCATED IN RETURN AIR SECTION.
  - 10. MAS ACCESSORY PROVIDED WITH ECONOMIZER. CONNECTION LOCATED IN BLOWER COMPARTMENT.
  - 11. WIRE SUPPLIED FOR ADDITION OF CRANKCASE HEATER ACCESSORY.
  - 12. OPTIONAL FT LOCATED IN COMPRESSOR COMPARTMENT.

**COMPONENT CODE**

AUX SW	AUXILIARY SWITCH	LAC	LOW AMBIENT COOLING CONTROL
BC	BLOWER CONTACTOR	LC	LIMIT CONTROL
CC	COMPRESSOR CONTACTOR	LPC	LOW PRESSURE CONTROL
CCH	CRANKCASE HEATER	MAS	MIX AIR SENSOR
COMP	COMPRESSOR	MRLC	MANUAL RESET LIMIT CONTROL
CT	CONTROL TRANSFORMER	NPC	NEGATIVE PRESSURE CONTROL
DISC	DISCONNECT SWITCH	OFM	OUTDOOR FAN MOTOR
FLMS	FLAME SENSOR	PL	PLUG
FT	FREEZE STAT	RC	RUN CAPACITOR
GFCO	GROUND FAULT CONVENIENCE OUTLET	SE	SPARK ELECTRODE
GL	GROUND LUG	TB	TERMINAL BLOCK
GND	GROUND	W	WIRE NUT
GV	GAS VALVE		
HPC	HIGH PRESSURE CONTROL		
IDM	INDOOR BLOWER MOTOR BELT DRIVE		
IDM	INDUCED DRAFT MOTOR		
IFC	INTEGRATED FURNACE CONTROL		

**WIRING INFORMATION**

LINE VOLTAGE  
 -FACTORY STANDARD \_\_\_\_\_  
 -FACTORY OPTION - - - - -  
 -FIELD INSTALLED - - - - -

LOW VOLTAGE  
 -FACTORY STANDARD \_\_\_\_\_  
 -FACTORY OPTION - - - - -  
 -FIELD INSTALLED - - - - -

REPLACEMENT WIRE  
 -MUST BE THE SAME SIZE AND TYPE OF INSULATION AS ORIGINAL (105 C.MIN.)

WARNING  
 -CABINET MUST BE PERMANENTLY GROUNDED AND CONFORM TO I.E.C., N.E.C., C.E.C., NATIONAL WIRING REGULATIONS, AND LOCAL CODES AS APPLICABLE.

**WIRE COLOR CODE**

BK	BLACK	O	ORANGE
BR	BROWN	PR	PURPLE
BL	BLUE	R	RED
G	GREEN	W	WHITE
GY	GRAY	Y	YELLOW

**WIRING DIAGRAM**  
 (-)LNL-B073  
 208-230/460/575V 3 PH, 60 HZ.  
 200-220/380-415V, 3 PH, 50 HZ

DR. BY MGR    APP. BY    DATE 5-19-08    DWG. NO. 90-102892-02    REV 04



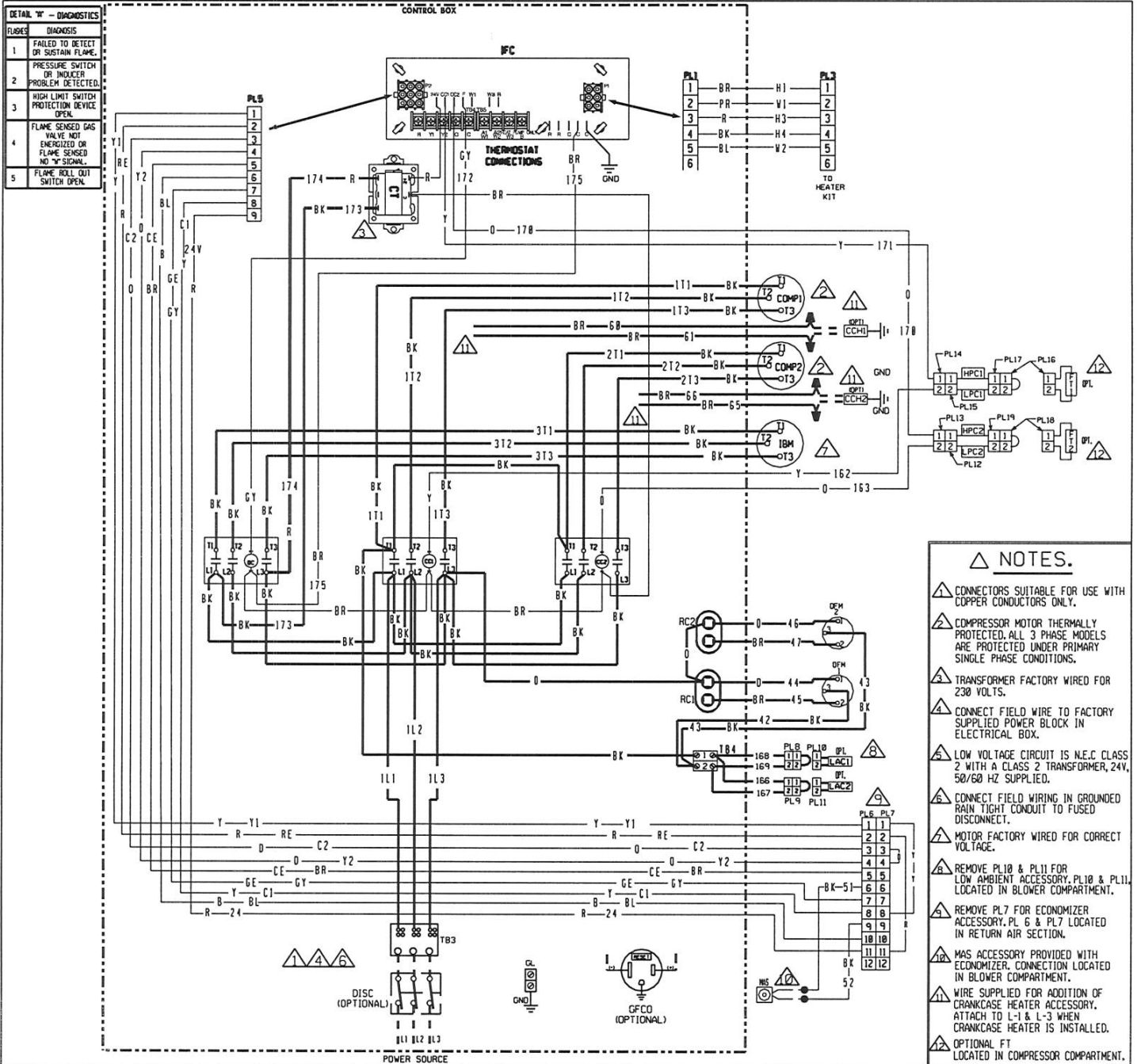

FLANGES	DIAGNOSIS
1	FAILED TO DETECT OR SUSTAIN FLAME.
2	PRESSURE SWITCH OR INDUCER PROBLEM DETECTED.
3	HIGH LIMIT SWITCH PROTECTION DEVICE OPEN.
4	FLAME SENSED GAS VALVE NOT ENERGIZED OR FLAME SENSED NO "SIGNAL".
5	FLAME ROLL OUT SWITCH OPEN.

- △ NOTES.**
- △ CONNECTORS SUITABLE FOR USE WITH COPPER CONDUCTORS ONLY.
  - △ COMPRESSOR MOTOR THERMALLY PROTECTED. ALL 3 PHASE MODELS ARE PROTECTED UNDER PRIMARY SINGLE PHASE CONDITIONS.
  - △ TRANSFORMER FACTORY WIRED FOR 230 VOLTS.
  - △ CONNECT FIELD WIRE TO FACTORY SUPPLIED POWER BLOCK IN ELECTRICAL BOX.
  - △ LOW VOLTAGE CIRCUIT IS N.E.C. CLASS 2 WITH A CLASS 2 TRANSFORMER, 24V, 50/60 HZ SUPPLIED.
  - △ CONNECT FIELD WIRING IN GROUNDED RAIN TIGHT CONDUIT TO FUSED DISCONNECT.
  - △ MOTOR FACTORY WIRED FOR CORRECT VOLTAGE.
  - △ REMOVE PL10 & PL11 FOR LOW AMBIENT ACCESSORY. PL10 & PL11 LOCATED IN BLOWER COMPARTMENT.
  - △ REMOVE PL7 FOR ECONOMIZER ACCESSORY. PL 6 & PL 7 LOCATED IN RETURN AIR SECTION.
  - △ MAS ACCESSORY PROVIDED WITH ECONOMIZER. CONNECTION LOCATED IN BLOWER COMPARTMENT.
  - △ WIRE SUPPLIED FOR ADDITION OF CRANKCASE HEATER ACCESSORY. ATTACH TO L-1 & L-3 WHEN CRANKCASE HEATER IS INSTALLED.
  - △ OPTIONAL FT LOCATED IN COMPRESSOR COMPARTMENT.

COMPONENT CODE	WIRING INFORMATION	WIRE COLOR CODE
BC BLOWER CONTACTOR CC COMPRESSOR CONTACTOR CCH CRANKCASE HEATER COMP COMPRESSOR CT CONTROL TRANSFORMER DISC DISCONNECT SWITCH FLMS FLAME SENSOR FT FREEZE STAT GFCD GROUND FAULT CONVENIENCE OUTLET GL GROUND LUG GND GROUND GV GAS VALVE HPC HIGH PRESSURE CONTROL IBM INDOOR BLOWER MOTOR BELT DRIVE IDM INDUCED DRAFT MOTOR IFC INTEGRATED FURNACE CONTROL	LINE VOLTAGE -FACTORY STANDARD -FACTORY OPTION -FIELD INSTALLED LOW VOLTAGE -FACTORY STANDARD -FACTORY OPTION -FIELD INSTALLED REPLACEMENT WIRE -MUST BE THE SAME SIZE AND TYPE OF INSULATION AS ORIGINAL (105° C MIN.) WARNING -CABINET MUST BE PERMANENTLY GROUNDED AND CONFORM TO I.E.C., N.E.C., C.E.C., AND LOCAL CODES AS APPLICABLE.	BK BLACK BR BROWN BL BLUE G GREEN GY GRAY O ORANGE PR PURPLE R RED W WHITE Y YELLOW
LAC LOW AMBIENT COOLING CONTROL LC LIMIT CONTROL LPC LOW PRESSURE CONTROL MAS MIX AIR SENSOR MRLC MANUAL RESET LIMIT CONTROL NPC NEGATIVE PRESSURE CONTROL OFM OUTDOOR FAN MOTOR PL PLUG RC RUN CAPACITOR SE SPARK ELECTRODE TB TERMINAL BLOCK WIRE NUT	LAG1 LAG2 LAG3 LAG4 LAG5 LAG6 LAG7 LAG8 LAG9 LAG10 LAG11 LAG12	<b>WIRING DIAGRAM</b> (-)RLNL-B090/102/120/150/151 208-230/460/575V 3 PH, 60 HZ. 200-220/380-415V, 3 PH, 50HZ
90-102892-01 REV 05	DR. BY MGR APP. BY [Signature] DATE 5-19-08	DWG. NO. 90-102892-01 REV 05





**BEFORE PURCHASING THIS APPLIANCE, READ IMPORTANT ENERGY COST AND EFFICIENCY INFORMATION AVAILABLE FROM YOUR RETAILER.**

### **GENERAL TERMS OF LIMITED WARRANTY**

Ruud will furnish a replacement for any part of this product which fails in normal use and service within the applicable periods stated, in accordance with the terms of the limited warranty.

**For Complete Details of the Limited Warranty, Including Applicable Terms and Conditions, See Your Local Installer or Contact the Manufacturer for a Copy.**

Compressor .....Five (5) Years  
Electric Resistance Heater Elements .....Five (5) Years  
\*Any Other Part.....One (1) Year

**\*All other parts and components carry a limited warranty of five years, provided they are single-phase products installed in a residential application.**

**Before proceeding with installation, refer to installation instructions packaged with each model, as well as complying with all Federal, State, Provincial, and Local codes, regulations, and practices.**

**Ruud Heating,  
Cooling and  
Water Heating**

P.O. Box 17010, Fort Smith, AR 72917



*"In keeping with its policy of continuous progress and product improvement, Ruud reserves the right to make changes without notice."*