



## 90 HIGH EFFICIENCY DOWNFLOW/ HORIZONTAL GAS FURNACES

The Rheem Value Series 90 High Efficiency line of downflow/horizontal gas furnaces are designed for utility rooms, closets, alcoves, attics or crawl spaces. The 90TS is shipped in the downflow configuration and is easily converted for horizontal **left-hand** airflow applications.

The design is certified by CSA.

### Features

- Low profile "34 inch" design is lighter and easier to handle and leaves room for optional accessories.
- Top electrical connections, left or right gas and condensate drainage connections on downflow models.
- Condensate drain for horizontal application provided standard.
- Integrated control board manages all operational functions and provides hookups for an electronic air cleaner.
- A slow-opening gas valve and a specially designed inducer system make it one of the quietest furnaces on the market today.
- Galvanized steel cabinet.
- Optional indoor or outdoor combustion air.
- Control board diagnostics.

A variety of cooling coils and plenums designed to use with the Rheem Value Series 90 gas furnaces are available as optional accessories for air conditioning models.

†A.F.U.E. (Annual Fuel Utilization Efficiency) calculated in accordance with Department of Energy test procedures.

### 90TS- SERIES

**Models with Input Rates  
from 45,000 to 120,000 BTU/HR  
[13.19 to 35.17 kW]**

(All Models 90% A.F.U.E.† or Above)





# 90 HIGH EFFICIENCY DOWNFLOW/HORIZONTAL GAS FURNACE

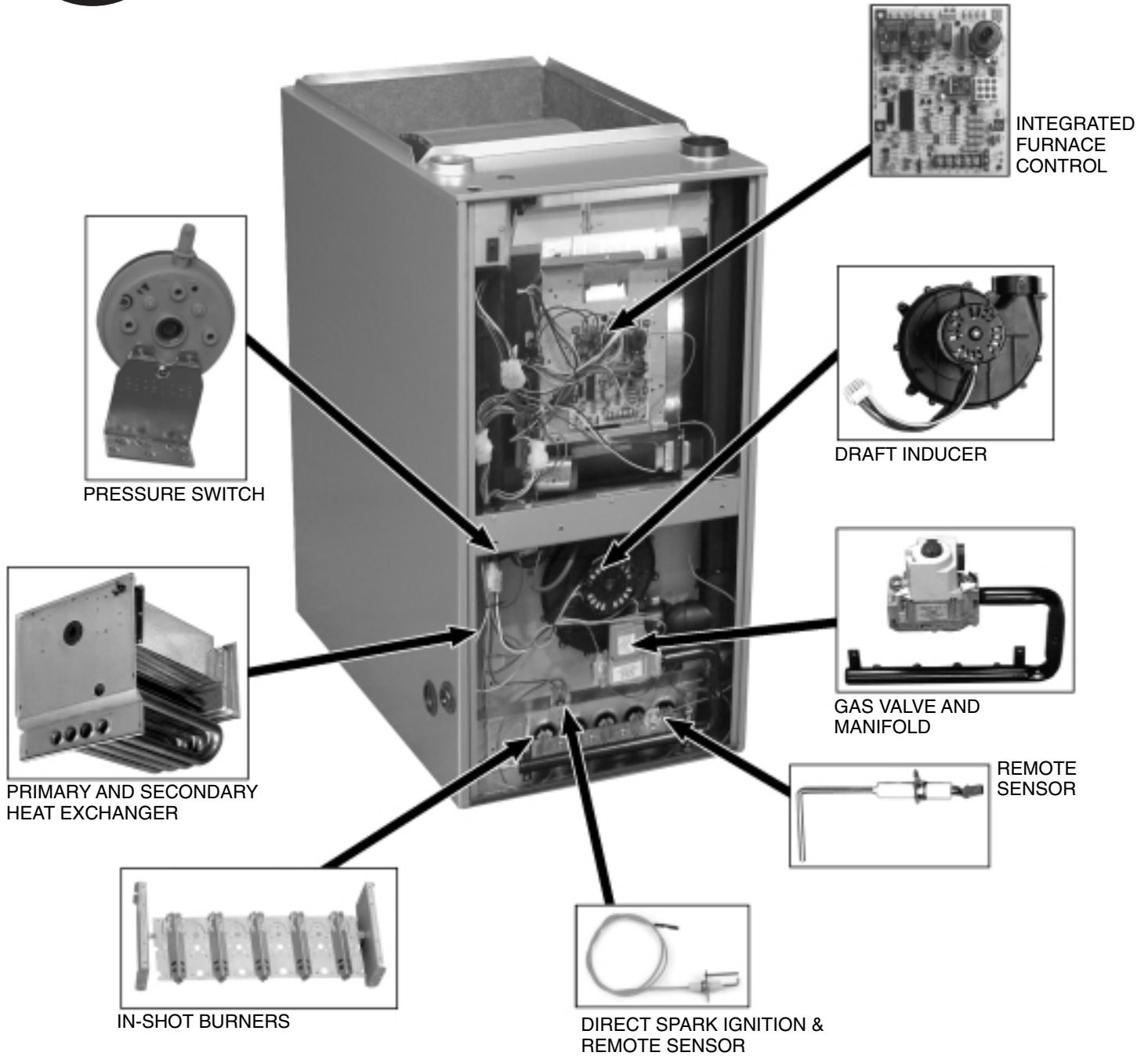

## STANDARD EQUIPMENT

Completely assembled and wired; heat exchanger; primary: 409 stainless steel, secondary: 29-4C stainless steel; induced draft; pressure switch; redundant main gas control; blower compartment door safety switch; solid state time on/off blower control; limit controls; manual shut-off valve; 100% safety lock out; cool fan off delay; field selectable heat fan off delay; one hour automatic retry; self-test diagnostics; control diagnostics; electronic air cleaner connections; pressure regulator for natural and L.P. (propane) gases; transformer; direct drive, multi-speed blower motor.  
(Please note: a thermostat is not included as standard equipment.)

## OPTIONAL EQUIPMENT

(See Accessory Page)

All models can be converted by a qualified distributor or local service dealer to use L.P. (propane) gas without changing burners. Factory approved kits must be used to convert from natural to L.P. (propane) gas and may be ordered as optional accessories from a parts distributor.

For L.P. (propane) operation, refer to Conversion Kit Index Form.

**WARNING**  
THIS FURNACE IS NOT APPROVED  
OR RECOMMENDED  
FOR USE IN MOBILE HOMES

**BEFORE PURCHASING THIS APPLIANCE, READ IMPORTANT ENERGY COST AND EFFICIENCY INFORMATION AVAILABLE FROM YOUR RETAILER.**

# PHYSICAL DATA AND SPECIFICATIONS

## DOWNFLOW/HORIZONTAL MODELS U.S. and Canadian Models

MODEL NUMBERS 90TS- SERIES	04EES**	06EES**	07EES**	07EFS**	09EJS**	09EGS**	10EGS**	12EHS**
INPUT-BTU/HR [kW] ①	45,000 [13.19]	60,000 [17.58]	75,000 [21.98]	75,000 [21.98]	90,000 [26.37]	90,000 [26.37]	105,000 [30.77]	120,000 [35.17]
HEATING CAPACITY BTU/HR [kW]	42,000 [12.31]	56,000 [16.41]	70,000 [20.51]	70,000 [20.51]	84,000 [24.61]	84,000 [24.61]	97,000 [28.43]	113,000 [33.12]
HIGH ALTITUDE INPUT [kW] ②	40,500 [11.87]	54,000 [15.83]	67,500 [19.78]	67,500 [19.78]	81,000 [23.73]	81,000 [23.73]	94,500 [27.70]	108,000 [31.65]
HIGH ALTITUDE OUTPUT CAPACITY [kW] ②	37,800 [11.07]	50,400 [14.77]	63,000 [18.46]	63,000 [18.46]	76,000 [22.27]	76,000 [22.27]	87,500 [25.64]	100,000 [29.31]
BLOWER (D x W) [mm]	11 x 7 [279 x 178]	11 x 7 [279 x 178]	11 x 7 [279 x 178]	12 x 7 [305 x 178]	12 x 11 [305 x 279]	12 x 11 [305 x 279]	12 x 11 [305 x 279]	11 x 10 [279 x 254]
MOTOR H.P. [W] SPEEDS-TYPE	1/2 [373] 4-PSC	1/2 [373] 3-PSC	1/2 [373] 3-PSC	3/4 [559] 3-PSC	1/2 [373] 3-PSC	3/4 [559] 3-PSC	3/4 [559] 3-PSC	3/4 [559] 3-PSC
MOTOR FULL LOAD AMPS	6.8	6.8	6.8	9.5	8.0	9.5	9.5	9.5
HEATING SPEED	Med-Low	Low	Med	Low	Med	Low	Low	Low
COOLING SPEED	High	High	High	High	High	High	High	High
HEAT EXT. STATIC PRESSURE (IN. W.C.) [kPa]	.10 [.025]	.12 [.029]	.12 [.029]	.12 [.029]	.15 [.037]	.15 [.037]	.20 [.049]	.20 [.049]
RATED EXT. STATIC PRESSURE (IN. W.C.) [kPa]	.50 [.12]	.50 [.12]	.50 [.12]	.50 [.12]	.50 [.12]	.50 [.12]	.50 [.12]	.50 [.12]
HEATING C.F.M. @ .2" W.C. E.S.P. [L/s]	890 [420]	885 [418]	1060 [500]	1275 [602]	1400 [661]	1400 [661]	1425 [673]	1565 [739]
COOLING C.F.M. @ .5" W.C. E.S.P. [L/s]	1220 [576]	1180 [557]	1150 [543]	1625 [767]	1570 [740]	1850 [873]	1820 [859]	2040 [963]
TEMPERATURE RISE RANGE °F [°C]	30-60 [16.7-33.3]	40-70 [22.2-38.9]	45-75 [25-41.7]	35-65 [19.4-36.1]	35-65 [19.4-36.1]	35-65 [19.4-36.1]	50-80 [27.8-44.4]	50-80 [27.8-44.4]
STANDARD FILTER [mm]	(2) 12" x 20" [305 x 508]	(2) 12" x 20" [305 x 508]	(2) 12" x 20" [305 x 508]	(2) 12" x 20" [305 x 508]	(2) 12" x 20" [305 x 508]	(2) 12" x 20" [305 x 508]	(2) 12" x 20" [305 x 508]	(2) 14" x 20" [609 x 508]
APPROX. SHIPPING WEIGHT (LBS.) [kg]	111 [50.3]	117 [53.1]	123 [55.8]	123 [55.8]	148 [67.1]	148 [67.1]	152 [68.9]	160 [72.6]
AFUE ③	92.0%	92.4%	92.0%	92.3%	92.4%	92.4%	92.0%	92.1%
CALIFORNIA SEASONAL EFFICIENCY ③	84.35%	86.46%	89.96%	85.00%	86.40%	86.40%	87.02%	87.37%

NOTES: All models are 115V, 60HZ, 1Ø. Gas connection size for all models is 1/2" [13 mm] N.P.T.

① See Conversion Kit Index Form for high altitude derate.

② Canadian installations only.

③ In accordance with D.O.E. test procedures.

## MODEL IDENTIFICATION

90	T	S	04E	E	S	01	
Efficiency	T = Downflow/ Horizontal Condensing	Design Series S = 3rd Design Series	Heating Input Designation		Blower Designation [mm]	Fuel Designation S = Natural Gas - CSA - United States & Canada (North American)	Rheem Value Series
			<u>Electric Ignition</u>	<u>Input BTU/HR [kW]</u>	E = Standard Cabinet 11 x 7 [279 x 178] 1/2 H.P. PSC		
			04E	45,000 [13.1]	F = Wide Cabinet 12 x 7 [305 x 178] 3/4 H.P. PSC		
			06E	60,000 [17.6]	G = Standard Cabinet 12 x 11 [305 x 279] 3/4 H.P. PSC		
			07E	75,000 [21.9]	H = Standard Cabinet 11 x 10 [279 x 254] 3/4 H.P. PSC		
			09E	90,000 [26.4]	J = Standard Cabinet 12 x 11 [305 x 279] 1/2 H.P. PSC		
			10E	105,000 [30.7]			
			12E	120,000 [35.2]			

[ ] Designates Metric Conversions

# DOWNFLOW MODELS

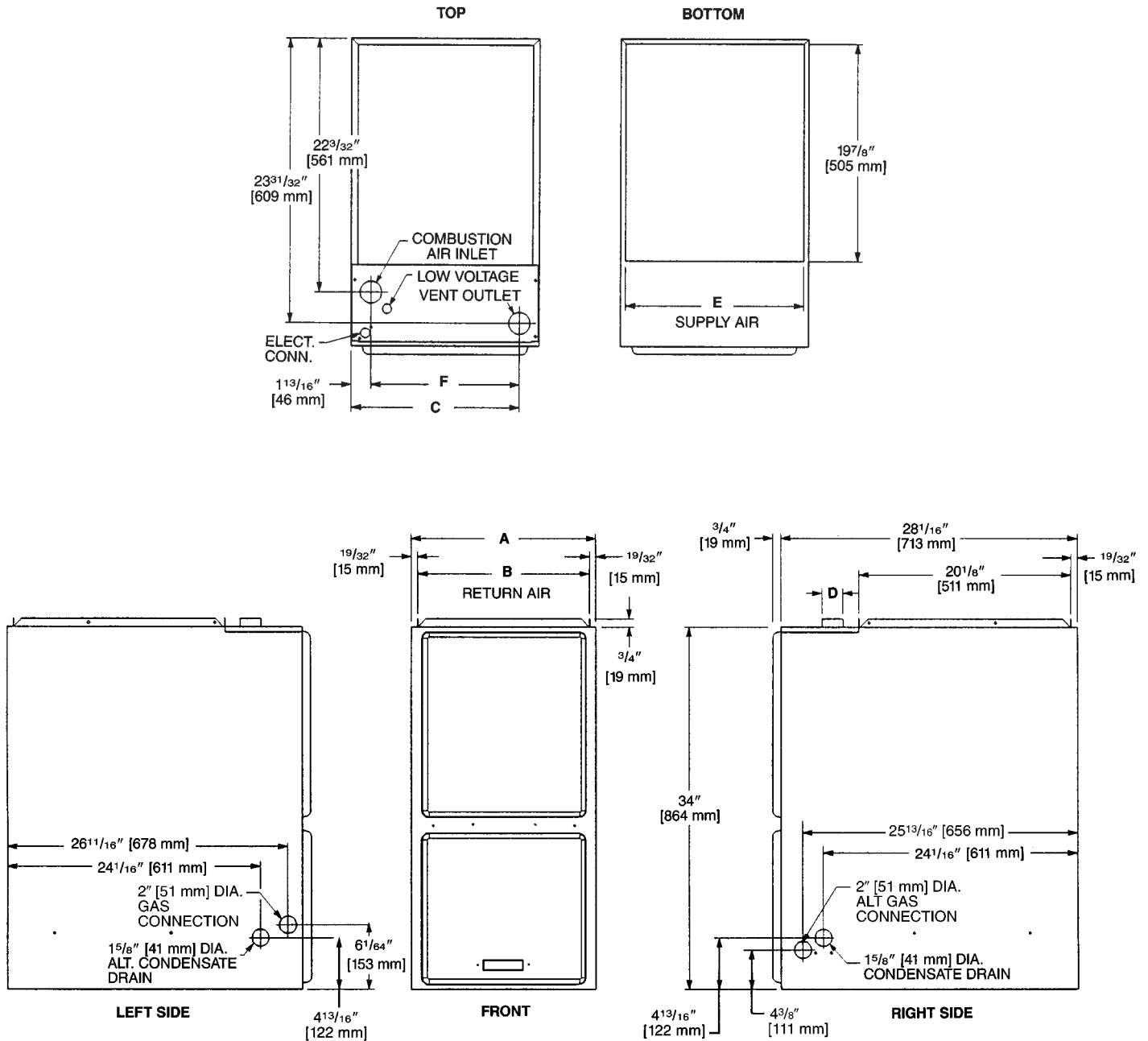

MODEL 90TS-	A	B	C	D	E	F	LEFT SIDE	MINIMUM CLEARANCE (IN.) [mm]					SHIP WGT. [kg]
								RIGHT SIDE	BACK	TOP	FRONT	VENT	
04	17 <sup>1</sup> / <sub>2</sub> [445]	16 <sup>11</sup> / <sub>32</sub> [415]	15 <sup>5</sup> / <sub>8</sub> [397]	2 [51]	16 <sup>5</sup> / <sub>8</sub> [422]	13 <sup>7</sup> / <sub>8</sub> [352]	0	0	0	1 [25]	2 [51]	0	111 [50]
06	17 <sup>1</sup> / <sub>2</sub> [445]	16 <sup>11</sup> / <sub>32</sub> [415]	15 <sup>5</sup> / <sub>8</sub> [397]	2 [51]	16 <sup>5</sup> / <sub>8</sub> [422]	13 <sup>7</sup> / <sub>8</sub> [352]	0	0	0	1 [25]	2 [51]	0	117 [53]
07EE	17 <sup>1</sup> / <sub>2</sub> [445]	16 <sup>11</sup> / <sub>32</sub> [415]	15 <sup>5</sup> / <sub>8</sub> [397]	2 [51]	16 <sup>5</sup> / <sub>8</sub> [422]	13 <sup>7</sup> / <sub>8</sub> [352]	0	0	0	1 [25]	2 [51]	0	123 [56]
07EF	21 [533]	19 <sup>27</sup> / <sub>32</sub> [504]	19 <sup>3</sup> / <sub>16</sub> [486]	2 [51]	20 <sup>1</sup> / <sub>8</sub> [511]	17 <sup>3</sup> / <sub>8</sub> [441]	0	0	0	1 [25]	2 [51]	0	123 [56]
09	21 [533]	19 <sup>27</sup> / <sub>32</sub> [504]	19 <sup>3</sup> / <sub>16</sub> [486]	2 [51]	20 <sup>1</sup> / <sub>8</sub> [511]	17 <sup>3</sup> / <sub>8</sub> [441]	0	0	0	1 [25]	2 [51]	0	148 [67]
10	21 [533]	19 <sup>27</sup> / <sub>32</sub> [504]	19 <sup>3</sup> / <sub>16</sub> [486]	2 [51]	20 <sup>1</sup> / <sub>8</sub> [511]	17 <sup>3</sup> / <sub>8</sub> [441]	0	0	0	1 [25]	2 [51]	0	152 [69]
12	24 <sup>1</sup> / <sub>2</sub> [622]	23 <sup>11</sup> / <sub>32</sub> [593]	22 <sup>5</sup> / <sub>8</sub> [575]	2 [51]	23 <sup>5</sup> / <sub>8</sub> [600]	20 <sup>7</sup> / <sub>8</sub> [530]	0	0	0	1 [25]	2 [51]	0	160 [73]

**IMPORTANT NOTE:** Horizontal furnace may be installed for horizontal left hand air supply **ONLY**. The condensate trap provided for horizontal application must be installed in the field beneath the unit as directed in the furnace Installation & Operating Instructions.

# HORIZONTAL MODELS

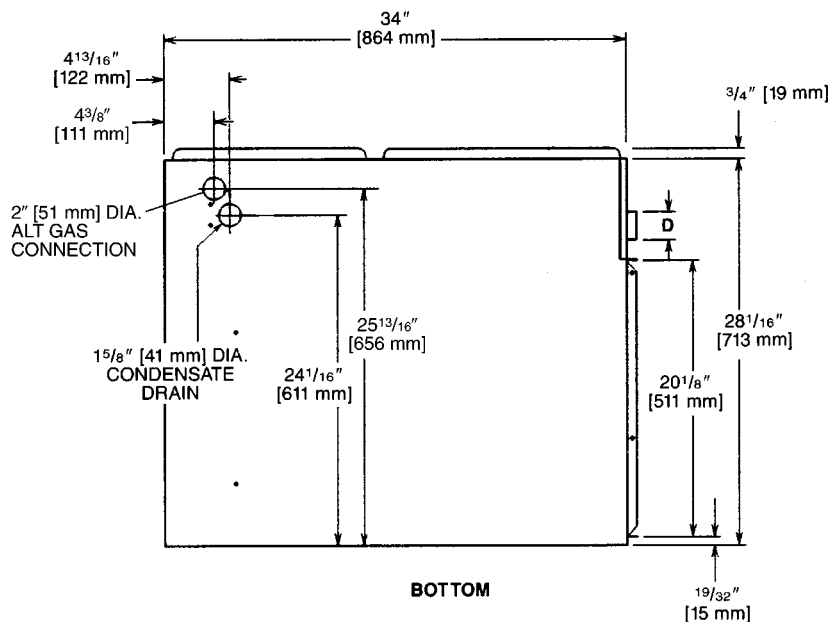
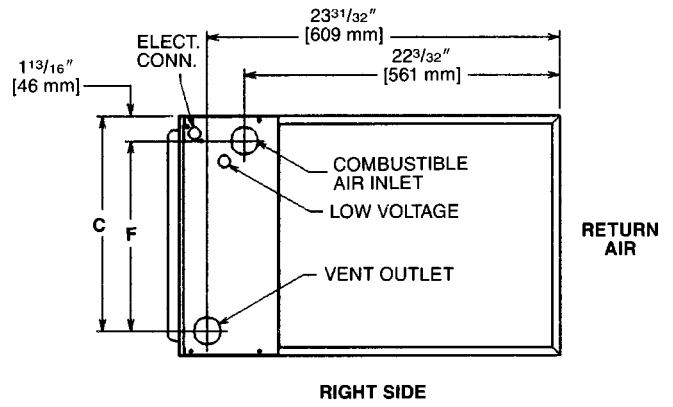
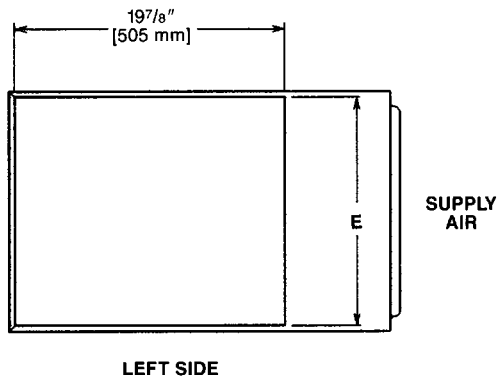
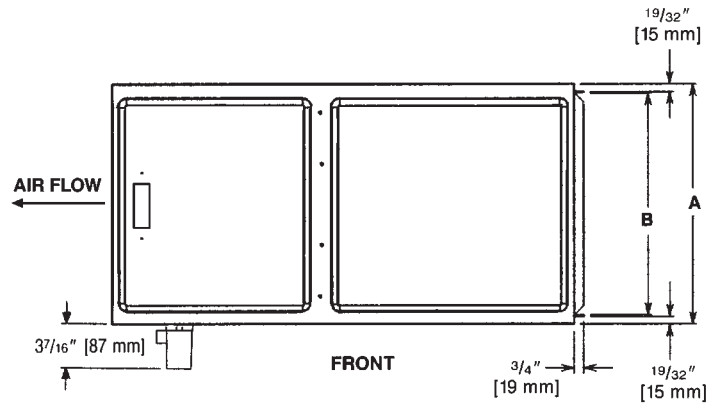
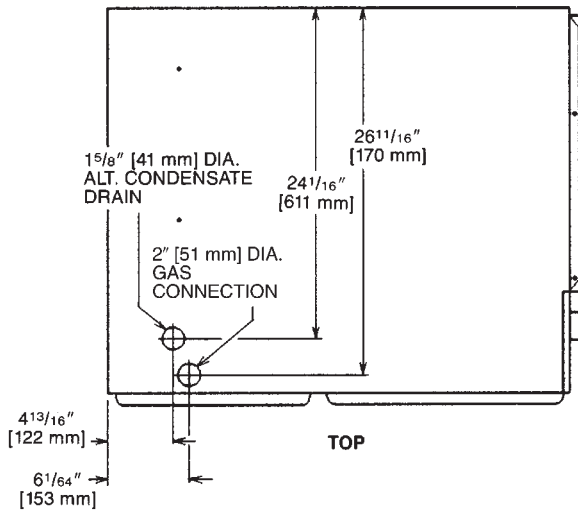

**IMPORTANT NOTE:** Horizontal furnace may be installed for horizontal left hand air supply **ONLY**. The condensate trap provided for horizontal application must be installed in the field beneath the unit as directed in the furnace Installation & Operating Instructions.

# BLOWER PERFORMANCE DATA—90TS MODELS

MODEL 90TS-	BLOWER SIZE IN. [mm]	MOTOR H.P. [W]	BLOWER SPEED	CFM [L/s] AIR DELIVERY EXTERNAL STATIC PRESSURE INCHES WATER COLUMN [kPa]						
				0.1 [.02]	0.2 [.05]	0.3 [.07]	0.4 [.10]	0.5 [.12]	0.6 [.15]	0.7 [.17]
04EES**	11 x 7 [279 x 178]	1/2 [373]	LOW	820 [387]	790 [373]	760 [359]	725 [342]	690 [326]	650 [306]	610 [288]
			MED-LO	<b>930 [439]</b>	<b>890 [420]</b>	<b>850 [401]</b>	<b>815 [384]</b>	<b>785 [370]</b>	<b>750 [354]</b>	<b>720 [340]</b>
			MED-HI	1150 [543]	1120 [528]	1090 [514]	1045 [493]	1002 [473]	950 [448]	900 [425]
06EES**	11 x 7 [279 x 178]	1/2 [373]	LOW	<b>910 [429]</b>	<b>885 [418]</b>	<b>860 [406]</b>	<b>815 [384]</b>	<b>770 [363]</b>	<b>725 [342]</b>	<b>680 [321]</b>
			MED	1115 [526]	1080 [510]	1045 [493]	1005 [474]	965 [455]	920 [434]	875 [413]
			HIGH	1365 [644]	1315 [620]	1270 [600]	1225 [578]	1180 [557]	1125 [491]	1070 [505]
07EES**	11 x 7 [279 x 178]	1/2 [373]	LOW	890 [420]	860 [406]	835 [394]	790 [373]	750 [354]	705 [332]	660 [311]
			MED	<b>1100 [519]</b>	<b>1060 [500]</b>	<b>1025 [484]</b>	<b>980 [462]</b>	<b>940 [443]</b>	<b>890 [420]</b>	<b>845 [399]</b>
			HIGH	1340 [632]	1295 [611]	1250 [590]	1200 [566]	1150 [543]	1090 [514]	1025 [484]
07EFS**	12 x 7 [305 x 178]	3/4 [559]	LOW	<b>1405 [668]</b>	<b>1375 [649]</b>	<b>1350 [637]</b>	<b>1310 [618]</b>	<b>1270 [599]</b>	<b>1235 [583]</b>	<b>1195 [564]</b>
			MED	1595 [753]	1560 [736]	1525 [720]	1480 [698]	1440 [679]	1380 [651]	1325 [625]
			HIGH	1835 [866]	1780 [840]	1730 [816]	1675 [791]	1625 [767]	1555 [734]	1480 [698]
09EJS**	12 x 11 [305 x 279]	1/2 [373]	LOW	1155 [545]	1125 [531]	1100 [519]	1080 [510]	1060 [500]	1000 [472]	940 [443]
			MED	<b>1420 [670]</b>	<b>1400 [661]</b>	<b>1380 [651]</b>	<b>1365 [644]</b>	<b>1350 [637]</b>	<b>1260 [594]</b>	<b>1175 [554]</b>
			HIGH	1605 [757]	1575 [743]	1550 [732]	1560 [736]	1570 [740]	1480 [698]	1395 [656]
09EGS**	12 x 11 [305 x 279]	3/4 [559]	LOW	<b>1420 [670]</b>	<b>1400 [661]</b>	<b>1380 [651]</b>	<b>1365 [644]</b>	<b>1350 [637]</b>	<b>1260 [594]</b>	<b>1175 [554]</b>
			MED	1605 [757]	1575 [743]	1550 [732]	1560 [736]	1570 [740]	1480 [698]	1395 [656]
			HIGH	2005 [946]	1965 [927]	1930 [910]	1890 [892]	1850 [873]	1765 [833]	1680 [793]
10EGS**	12 x 11 [305 x 279]	3/4 [559]	LOW	<b>1460 [689]</b>	<b>1425 [672]</b>	<b>1390 [656]</b>	<b>1375 [649]</b>	<b>1360 [642]</b>	<b>1280 [604]</b>	<b>1200 [566]</b>
			MED	1680 [793]	1645 [776]	1615 [762]	1585 [748]	1560 [736]	1490 [703]	1420 [670]
			HIGH	2055 [970]	2000 [944]	1940 [915]	1880 [887]	1820 [859]	1745 [823]	1675 [790]
12EHS**	11 x 10 [279 x 245]	3/4 [559]	LOW	<b>1590 [750]</b>	<b>1565 [738]</b>	<b>1540 [727]</b>	<b>1505 [710]</b>	<b>1475 [696]</b>	<b>1425 [672]</b>	<b>1375 [649]</b>
			MED	1840 [868]	1820 [860]	1800 [850]	1750 [826]	1700 [802]	1645 [776]	1590 [750]
			HIGH	2315 [1093]	2250 [1062]	2185 [1031]	2110 [996]	2040 [963]	1965 [927]	1890 [892]

NOTE: Recommended blower speeds are in bold.

[ ] Designates Metric Conversions

## GENERAL TERMS OF LIMITED WARRANTY

Rheem will furnish a replacement for any part of this product which fails in normal use and service within the applicable period stated, in accordance with the terms of the limited warranty.

For Complete Details of the Limited Warranty, Including Applicable Terms and Conditions, See Your Local Installer or Contact the Manufacturer for a Copy.

Primary and Secondary Heat Exchanger ...Twenty (20) Years  
\*Any Other Part.....Five (5) Years

\*This five year limited warranty is applicable only to single-phase products installed in residential applications on or after January 1, 2001.

# ACCESSORIES—DOWNFLOW

## VENT TERMINATION KITS CONCENTRIC: HORIZONTAL/ VERTICAL =

**RXGY-E03A** (US & Canadian Installations)

**HORIZONTAL TWO PIPE:** RXGY-D02, RXGY-D03, RXGY-D04  
(US Installations)

**RXGY-D02A, RXGY-D03A, RXGY-D04A** (Canadian Installations)

**RXGY-G02** (US Only)

**CONDENSATE PUMP KIT:** RXGY-B01

**NEUTRALIZER KIT:** RXGY-A01

**FOSSIL FUEL KIT:** RXPF-F01, RXPF-F02 (TVA)

## PLENUM DATA FOR “A” COILS

Plenum adapters are required in some applications when plenum and furnace size do not match.

FURNACE WIDTH IN. [mm]	PLENUM WIDTH IN. [mm]	PLENUM ADAPTER DOWNFLOW	COIL PLENUM
17 1/2 [445]	16 1/4 [413]	RXAA-C186	RXAL-B16BU
17 1/2 [445]	20 1/4 [514]	RXAA-C173	RXAL-B20BU
17 1/2 [445]	21 5/8 [549]	RXAA-C187	RXAL-B21BU
17 1/2 [445]	25 1/4 [641]	RXAA-C174	RXAL-B25BU
21 [533]	25 1/4 [641]	RXAA-C175	RXAL-B25BU
21 [533]	22 1/4 [565]	RXAA-C176	RXAL-B22BU
21 [533]	21 5/8 [549]	RXAA-C188	RXAL-B21BU
24 1/2 [622]	25 1/4 [641]	RXAA-C177	RXAL-B25BU
24 1/2 [622]	21 5/8 [549]	RXAA-C187	RXAL-B21BU

## COMBUSTIBLE FLOOR BASE: RXGC-B17, RXGC-B21, RXGC-B24

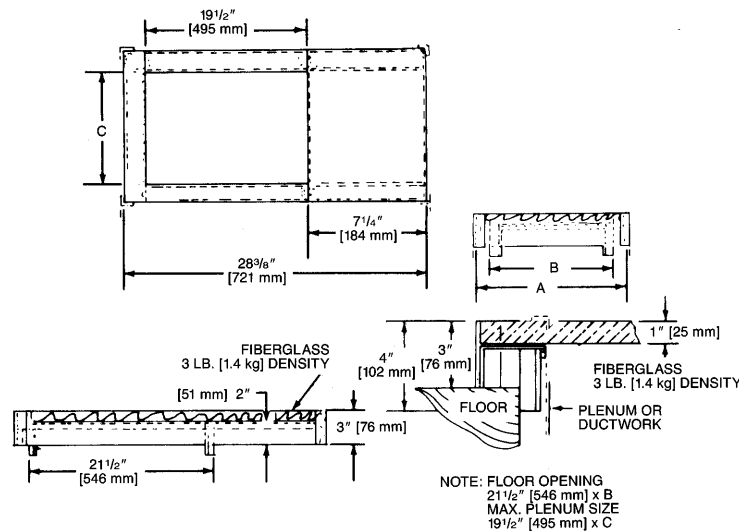

## EXTERNAL TOP MOUNT FILTER RACK: RXGF-CC

## INTERNAL FILTER RACK FOR AIR RETURN DUCT: RXGF-DB\*

Each order contains (1) one box of 10 filter racks supplied without filters.

\*Filters available through PROSTOCK®.

FILTER RACK FILTER SIZES® INCHES [mm]	
MODEL 90TS-	RXGF-CC
04	(2) 12 x 20 [305 x 508]
06	(2) 12 x 20 [305 x 508]
07	(2) 12 x 20 [305 x 508]
09	(2) 12 x 20 [305 x 508]
10	(2) 12 x 20 [305 x 508]
12	(2) 14 x 20 [305 x 508]

\*Filter racks are shipped without filters.

## RXGP-F03

**TWINNING KIT**—is for use with Rheem Value Series Gas Furnaces for parallel operation requirements.

## FOR HIGH ALTITUDES:

*HIGH ALTITUDE KIT:
F04-105 KBTU/H
F06-45/60/90 KBTU/H
F05-120 KBTU/H
F07-75 KBTU/H

\*For installations over 5000 ft.

## OPTION CODE FOR HIGH ALTITUDE: U.S. & Canada – 278

**NOTE:** High altitude kits and options do **NOT** include additional burner orifices. If a burner orifice change is necessary, they must be ordered through PROSTOCK®. See Installation Instructions for more information.

Option – 278 furnaces are shipped with #51 DMS orifices installed. This is one drill size smaller than standard furnaces to account for expected average elevations and heating values typically seen in these areas.

**CAUTION:** Always follow National Fuel Gas Code (NFGC) guidelines when converting furnaces for high altitudes.

For all installations above 2000 ft. (including all option – 278 models), the burner orifice size needs to be recalculated and verified. A burner orifice change may still be required. See Installation Instructions for more information.

**NOTE:** For Canadian installations only, an optional derate (manifold gas pressure reduction) method may be used to adjust the furnace for altitude. See Installation Instructions for more information. This optional method may **NOT** be used for U.S. installations.

[ ] Designates Metric Conversions

## THERMOSTATS



**100-Series \***  
Non-Programmable



**200-Series \***  
Programmable



**300-Series \***  
Deluxe Programmable  
**400-Series \*** Special  
Applications/Programmable

**500-Series \***  
Communicating/  
Programmable

Brand	Unique Model Number Prefix	Descriptor (3 Characters)	Series (3 Characters)	System (2 Characters)	Type (2 Characters)
RHC	-	TST	101	GE	MS
RHC=Rheem		TST=Thermostat	100=Non-Programmable 200=Programmable 300=Deluxe Programmable 400=Special Applications/Programmable 500=Communicating/Programmable	GE=Gas/Oil/Electric HP=Heat Pump MD=Modulating Furnace DF=Dual Fuel UN=Universal AC/HP/GE CM=Communicating	SS=Single-Stage MS=Multi-Stage

\* Photos are representative. Actual models may vary.

For detailed thermostat match-up information, see specification sheet form number T11-001.

**Before proceeding with installation, refer to installation instructions packaged with each model, as well as complying with all Federal, State, Provincial, and Local codes, regulations, and practices.**

**Rheem Heating,  
Cooling and  
Water Heating**

P.O. Box 17010, Fort Smith, AR 72917



*"In keeping with its policy of continuous progress and product improvement, Rheem reserves the right to make changes without notice."*