

# CONDENSING UNITS

**Comfort Control<sup>2</sup> System™**

Equipped with

**Comfort Control<sup>2</sup> System™**

- Serial communication enabled
- Increased system reliability and efficiency
- 32+ on-board diagnostic and operating codes
- *Active Protection™* with homeowner "Call for Service" alert
- Exclusive Design with dual 7-segment LED display

**R410A**  
earth friendly refrigerant

## RASL- JEC

18 Seer Two-Stage Cooling

Efficiencies up to 19.50 SEER/14.30 EER

Nominal Size 2 to 5 Tons [7.03 kW] to [17.6 kW]

## Five Models

Cooling Capacity

24,600 to 57,200 BTU/HR

[7.21 kW] to [16.76 kW]



**Rheem**  
**Prestige**  
S E R I E S

The Rheem *Prestige Series™* High Efficiency Two-Stage RASL-JEC Condensing Unit was designed with performance in mind. These units offer comfort, energy conservation and dependability for single, multi-family and light commercial applications. The Rheem *Prestige Series™* Two-Stage RASL- JEC Condensing Units are the result of an ongoing development program for improved efficiencies. With system SEER's as high as 19.5, these units continue a tradition of delivering high efficiency.

- Industry's lowest profile design: 33" maximum height
- The *Comfort Control<sup>2</sup> System™* provides over 32+ on-board diagnostics and fault history codes for condensing units with single-phase compressors by detecting system and electrical problems. The integrated diagnostics with *Active Protection™* prevents compressor operation when potentially harmful conditions are detected. Sends "Call for Service" alert notification to the thermostat to alert the homeowner of required service.
- Serial Communication Enhanced – When installed with a Serial Communicating Air Handler (RHPL/RHPN-HM\*\*\*\*JC) and user interface control (RHC-TST501CMMS) Series 500 thermostat this unit offers 4 or 2 wire installation, auto-configuration, and diagnostic messaging with full communicating capability.
- Legacy Enabled – Unit can be conventionally wired using 24VAC with non-communicating Rheem Prestige air-handlers or furnaces with non-communicating thermostat.
- Features a 10-year conditional unit replacement warranty and 10-year parts warranty when properly installed with a new Rheem air handler or Rheem indoor coil with a Rheem gas furnace. See product warranty card for additional information.
- Reliable Two-Stage operation for precise temperature control with On-Demand dehumidification feature. When matched with ECM gas furnace or air-handler, the system adjusts airflow to help control humidity for unsurpassed comfort in the cooling mode.
- All controls are accessible by removing one service panel. Removable top grille provides access to the condenser fan motor and condenser coil.
- Attractive, louvered wrap-around jacket protects the coil from yard hazards and weather extremes. Top grille is steel reinforced for extra strength. Cabinet is powder painted for all-weather protection.
- For quiet operation and improved efficiency, models feature an ECM two-speed condenser fan motor with a 3-blade outdoor fan.
- All models meet or exceed a 1000-hour salt spray test per ASTM B117 Standard Practice for Operating Salt Spray Testing Apparatus.

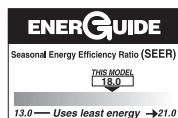

**"Proper sizing and installation of equipment is critical to achieve optimal performance. Split system air conditioners and heat pumps must be matched with appropriate coil components to meet ENERGY STAR criteria. Ask your Contractor for details or visit [www.energystar.gov](http://www.energystar.gov) <<http://www.energystar.gov/>>."**

# FEATURES & BENEFITS OF THE COMFORT CONTROL<sup>2</sup> SYSTEM™

- The Rheem exclusive Dual 7-Segment LED Display easily shows system operating status codes and diagnostic codes.

- A Sealed Switch replaces the standard contactor and features optical control and latching mechanism. The sealed switch prevents infiltration of insects and dust. A minimal switching arc, by the optical control, offers greater reliability. The latching mechanism consumes less power while reducing chatter.



- The Status Indication and System Diagnostics feature thermostat communication capability, built-in diagnostics, current sensing and high & low pressure switch monitoring. The thermostat communication capability alerts the homeowner to any necessary service requirements. Faster, more accurate service is provided by the built-in diagnostics, by providing the HVAC professional with dependable information. In addition, high and low pressure-switch monitoring prevents the system from operating outside of its normal parameters.



- The fault recall feature will allow for the last six fault-codes to be displayed, and will retain these codes even if power failure occurs.
- Built-in short-cycle protection allows the compressor to restart easily without oil removal.
- A 30-second minimum run-time for every compressor call allows the oil to return to the compressor.
- *Active Protection* monitors the system to prevent nuisance lockouts and prevents compressor operation when potentially harmful conditions are detected.
- The compressor and fan are controlled independently, which reduces the starting load and light dimming.
- A manual push-button is offered to operate the compressor and fan for 5 seconds to allow for an operation check.
- In order to save time and money, replacement automotive fuses can be utilized instead of replacing the entire control board.

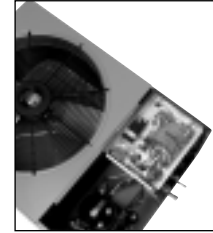

## STANDARD FEATURES

### RASL- JEC Condensing Units

1. Scroll compressor is hermetically sealed and incorporates internal high temperature motor overload protection, and durable insulation on the motor windings. It is externally mounted on rubber grommets to reduce vibration and noise.
2. Compressors have an internal pressure relief assembly to protect against excessive pressure differential.
3. All refrigerant connections are on the exterior of the unit, located close to the ground for neat appearing installations.
4. Cabinet is constructed of powder painted galvanized steel. The full wrap-around louvered grille protects the coil from damage.
5. Sound Blanket-enhanced compressor sound blanket is standard.
6. Copper tube—aluminum fin coils are used on all models.
7. The control box is located in the top corner of the cabinet providing for easy access through a service panel.
8. Service valves are standard on all models.
9. Field connections for power and control wiring are kept separate.
10. Every unit is factory charged and run-tested.
11. Separate compressor compartment for easy service access.
12. Drawn, painted base pan for extra corrosion resistance and sound reduction.
13. The **RASL- JEC** has a 10-year limited parts warranty, plus a 10-year conditional unit replacement warranty. Refer to the General Terms of Limited Warranty for more details.
14. **Hard Start Kits**—Standard on all JEC models.
15. Control Box Cover.
16. The RASL- JEC is shipped with a liquid line filter drier, and also features factory-installed low and high pressure controls.

## Problem-Solving Accuracy

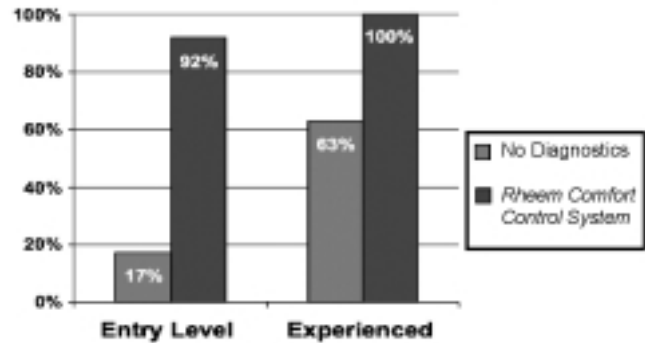

## SCROLL COMPRESSOR

### 024 & 036 nominal capacities

- Single scroll Ultra-Tech two-stage compressor
- Operates at 50% capacity in non peak conditions to improve efficiency and comfort (humidity control)



### 039, 048 & 60 nominal capacities

- Dual Drive scroll compressors – Tandem
- Operates at 50% capacity on first compressor in non peak conditions to improve efficiency and comfort (humidity control)
- Compressor “A” operated by control board “A” Compressor “B” operated by control board “B”.



## Accessories

- **Low Ambient Control**—Cycles outdoor fan to maintain adequate condensing pressures assuring liquid refrigerant flow to the coil. Allows indoor cooling with outdoor temperatures down to 0°F [-17.8°C]. (Model No. RXAD-A08). It is recommended that this control be installed in units to be operated at outdoor ambient temperatures under 70°F [21°C].
- **Thermostats**



**100-Series \***  
Non-Programmable



**200-Series \***  
Programmable



**300-Series \***  
Deluxe Programmable  
**400-Series \*** Special  
Applications/Programmable

**500-Series \***  
Communicating/  
Programmable

Brand	Unique Model Number Prefix	Descriptor (3 Characters)	Series (3 Characters)	System (2 Characters)	Type (2 Characters)
RHC	-	TST	101	GE	MS
RHC=Rheem		TST=Thermostat	100=Non-Programmable 200=Programmable 300=Deluxe Programmable 400=Special Applications/ Programmable 500=Communicating/ Programmable	GE=Gas/Oil/Electric HP=Heat Pump MD=Modulating Furnace DF=Dual Fuel UN=Universal AC/HP/GE CM=Communicating	SS=Single-Stage MS=Multi-Stage

\* Photos are representative. Actual models may vary.

For detailed thermostat match-up information, see specification sheet form number T11-001.

### IMPORTANT:

The *Comfort Control<sup>2</sup> System™* requires a communicating RHPL/RHPN-HM\*\*\*JC Air Handler and a 500-Series Thermostat.

- **Compressor Crankcase Heater** (Model No. 44-17402-44CCH) Add to minimize refrigeration migration and to help eliminate any startup noise or bearing “wash out”.

[ ] Designates Metric Conversions

# Model Number Identification

<b>R</b>	<b>A</b>	<b>S</b>	<b>L</b>	—	<b>024</b>	<b>J</b>	<b>EC</b>
RHEEM	REMOTE CONDENSING UNIT	18-SEER	DESIGN SERIES		COOLING CAPACITY	ELECTRICAL DESIGNATION	EC = EQUIPPED WITH THE COMFORT CONTROL <sup>2</sup> SYSTEM™
			L = FIRST DESIGN SERIES		024 = 24,000 BTU/HR [7.03 kW] 036 = 36,000 BTU/HR [10.55 kW] 039 = 39,000 BTU/HR [11.43 kW] 048 = 48,000 BTU/HR [14.07 kW] 060 = 60,000 BTU/HR [17.6 kW]	J = 208/230V-1-60	

## Performance Data @ ARI Standard Conditions—Cooling

Outdoor Unit RASL-	Model Numbers		Stage	ARI Cooling Performance 80°F [26.5°C] DB / 67°F [19.5°C] WB Indoor Air 95°F [35°C] DB Outdoor Air							
				Net Sensible BTU/H [kW]	Net Latent BTU/H [kW]	ARI Ratings			Indoor Airflow CFM [L/s]	Sound Rating db	
						Total Capacity BTU/H [kW]	SEER	EER			
REV. 10/8/2008	RCSN-H*2421A* ①	RHPN-HM2421	1	13,700 [4.0]	5,100 [1.5]	24,600 [7.2]	18.50	14.30	600 [283]	71	
2			17,700 [5.2]	6,900 [2.0]	775 [366]				74		
1 - dehumid			12,600 [3.7]	5,700 [1.7]	500 [236]				71		
2 - dehumid			16,750 [4.9]	7,650 [2.2]	650 [307]				74		
024JEC	RCFM-H*2417A*	RGFD-06?MCK?	1	13,400 [3.9]	5,200 [1.5]	24,400 [7.1]	16.00	12.65	600 [283]	71	
			2	17,500 [5.1]	6,900 [2.0]				800 [378]	74	
		RGFD-07?MCK?	1	13,400 [3.9]	5,200 [1.5]	24,400 [7.1]	16.00	12.75	600 [283]	71	
			2	17,500 [5.1]	6,900 [2.0]				800 [378]	74	
		RGGD-06?MCK?	1	13,400 [3.9]	5,200 [1.5]	24,600 [7.2]	16.50	12.95	600 [283]	71	
			2	17,650 [5.2]	6,950 [2.0]				800 [378]	74	
		RGGD-07?MCK?	1	13,400 [3.9]	5,200 [1.5]	24,400 [7.1]	16.50	12.85	625 [295]	71	
			2	17,450 [5.1]	6,950 [2.0]				800 [378]	74	
		RGJD-06?MCK?	1	13,400 [3.9]	5,200 [1.5]	24,600 [7.2]	16.50	12.95	600 [283]	71	
			2	17,650 [5.2]	6,950 [2.0]				800 [378]	74	
		RGJD-07?MCK?	1	13,400 [3.9]	5,200 [1.5]	24,400 [7.1]	16.50	12.85	625 [295]	71	
			2	17,450 [5.1]	6,950 [2.0]				800 [378]	74	
		RGLR-07?AMK?	1	13,500 [4.0]	5,200 [1.5]	24,600 [7.2]	16.50	13.15	600 [283]	71	
			2	17,650 [5.2]	6,950 [2.0]				800 [378]	74	
		RGPR-05?BMK?	1	13,350 [3.9]	5,150 [1.5]	24,600 [7.2]	16.00	12.95	600 [283]	71	
			2	17,650 [5.2]	6,950 [2.0]				775 [366]	74	
		RGPR-07?AMK?	1	13,400 [3.9]	5,200 [1.5]	24,600 [7.2]	16.50	13.05	600 [283]	71	
			2	17,650 [5.2]	6,950 [2.0]				800 [378]	74	
		RCFM-H*2417A*+RXMD-C06	Coil Only	1	13,050 [3.8]	5,050 [1.5]	24,000 [7.0]	14.50	11.80	600 [283]	71
				2	17,200 [5.0]	6,800 [2.0]				800 [378]	74
		RCFM-H*2421A*	RGFD-06?MCK?	1	13,400 [3.9]	5,200 [1.5]	24,400 [7.1]	16.00	12.70	600 [283]	71
				2	17,500 [5.1]	6,900 [2.0]				800 [378]	74
			RGFD-07?MCK?	1	13,400 [3.9]	5,200 [1.5]	24,400 [7.1]	16.00	12.80	600 [283]	71
				2	17,450 [5.1]	6,950 [2.0]				800 [378]	74
RGGD-06?MCK?	1		13,400 [3.9]	5,200 [1.5]	24,600 [7.2]	16.50	13.00	600 [283]	71		
	2		17,650 [5.2]	6,950 [2.0]				800 [378]	74		
RGGD-07?MCK?	1		13,400 [3.9]	5,200 [1.5]	24,400 [7.1]	16.50	12.90	625 [295]	71		
	2		17,450 [5.1]	6,950 [2.0]				800 [378]	74		
RGJD-06?MCK?	1		13,400 [3.9]	5,200 [1.5]	24,600 [7.2]	16.50	13.00	600 [283]	71		
	2		17,650 [5.2]	6,950 [2.0]				800 [378]	74		
RGJD-07?MCK?	1		13,400 [3.9]	5,200 [1.5]	24,400 [7.1]	16.50	12.90	625 [295]	71		
	2		17,450 [5.1]	6,950 [2.0]				800 [378]	74		
RGLR-07?AMK?	1		13,500 [4.0]	5,200 [1.5]	24,600 [7.2]	16.50	13.15	600 [283]	71		
	2		17,650 [5.2]	6,950 [2.0]				800 [378]	74		
RGPR-05?BMK?	1		13,350 [3.9]	5,150 [1.5]	24,600 [7.2]	16.00	12.95	600 [283]	71		
	2		17,650 [5.2]	6,950 [2.0]				775 [366]	74		
RGPR-07?AMK?	1		13,400 [3.9]	5,200 [1.5]	24,600 [7.2]	16.50	13.10	600 [283]	71		
	2		17,650 [5.2]	6,950 [2.0]				800 [378]	74		
RCFM-H*2421A*+RXMD-C06	Coil Only		1	13,050 [3.8]	5,050 [1.5]	24,000 [7.0]	14.50	11.80	600 [283]	71	
			2	17,200 [5.0]	6,800 [2.0]				800 [378]	74	

① Highest sales volume tested combination required by DOE test procedures.

[ ] Designates Metric Conversions

# Performance Data @ ARI Standard Conditions—Cooling

Outdoor Unit RASL-	Model Numbers		Stage	ARI Cooling Performance 80°F [26.5°C] DB / 67°F [19.5°C] WB Indoor Air 95°F [35°C] DB Outdoor Air							
				Net Sensible BTU/H [kW]	Net Latent BTU/H [kW]	ARI Ratings			Indoor Airflow CFM [L/s]	Sound Rating db	
	ID Coil	ID Air Mover				Total Capacity BTU/H [kW]	SEER	EER			
REV. 10/8/2008	RCFN-H*2417A*	RGFD-06?MCK?	1	13,650 [4.0]	5,050 [1.5]	24,400 [7.1]	17.50	13.50	600 [283]	71	
			2	17,550 [5.1]	6,850 [2.0]				800 [378]	74	
		RGFD-07?MCK?	1	13,650 [4.0]	5,050 [1.5]	24,400 [7.1]	17.50	13.60	600 [283]	71	
			2	17,550 [5.1]	6,850 [2.0]				800 [378]	74	
		RGGD-06?MCK?	1	13,600 [4.0]	5,100 [1.5]	24,600 [7.2]	18.00	13.85	600 [283]	71	
			2	17,700 [5.2]	6,900 [2.0]				800 [378]	74	
		RGGD-07?MCK?	1	13,600 [4.0]	5,100 [1.5]	24,400 [7.1]	17.50	13.70	625 [295]	71	
			2	17,550 [5.1]	6,850 [2.0]				800 [378]	74	
		RGJD-06?MCK?	1	13,600 [4.0]	5,100 [1.5]	24,600 [7.2]	18.00	13.85	600 [283]	71	
			2	17,700 [5.2]	6,900 [2.0]				800 [378]	74	
		RGJD-07?MCK?	1	13,600 [4.0]	5,100 [1.5]	24,400 [7.1]	17.50	13.70	625 [295]	71	
			2	17,550 [5.1]	6,850 [2.0]				800 [378]	74	
		RGLR-07?AMK?	1	13,700 [4.0]	5,100 [1.5]	24,600 [7.2]	18.00	14.00	600 [283]	71	
			2	17,700 [5.2]	6,900 [2.0]				800 [378]	74	
		RGPR-05?BMK?	1	13,650 [4.0]	5,050 [1.5]	24,600 [7.2]	17.50	13.80	600 [283]	71	
			2	17,700 [5.2]	6,900 [2.0]				775 [366]	74	
		RGPR-07?AMK?	1	13,700 [4.0]	5,100 [1.5]	24,600 [7.2]	18.00	13.90	600 [283]	71	
			2	17,700 [5.2]	6,900 [2.0]				800 [378]	74	
		RCFN-H*2417A*+RXMD-C06	Coil Only	1	13,250 [3.9]	4,950 [1.5]	24,000 [7.0]	15.50	12.55	600 [283]	71
				2	17,250 [5.1]	6,750 [2.0]				775 [366]	74
024JEC	RCFN-H*2421A*	RGFD-06?MCK?	1	13,650 [4.0]	5,050 [1.5]	24,400 [7.1]	17.50	13.50	600 [283]	71	
			2	17,550 [5.1]	6,850 [2.0]				800 [378]	74	
		RGFD-07?MCK?	1	13,650 [4.0]	5,050 [1.5]	24,400 [7.1]	17.50	13.65	600 [283]	71	
			2	17,550 [5.1]	6,850 [2.0]				800 [378]	74	
		RGGD-06?MCK?	1	13,600 [4.0]	5,100 [1.5]	24,600 [7.2]	18.00	13.85	600 [283]	71	
			2	17,700 [5.2]	6,900 [2.0]				800 [378]	74	
		RGGD-07?MCK?	1	13,600 [4.0]	5,100 [1.5]	24,600 [7.2]	17.50	13.75	625 [295]	71	
			2	17,750 [5.2]	6,850 [2.0]				800 [378]	74	
		RGJD-06?MCK?	1	13,600 [4.0]	5,100 [1.5]	24,600 [7.2]	18.00	13.85	600 [283]	71	
			2	17,700 [5.2]	6,900 [2.0]				800 [378]	74	
		RGJD-07?MCK?	1	13,600 [4.0]	5,100 [1.5]	24,600 [7.2]	17.50	13.75	625 [295]	71	
			2	17,750 [5.2]	6,850 [2.0]				800 [378]	74	
		RGLR-07?AMK?	1	13,700 [4.0]	5,100 [1.5]	24,600 [7.2]	18.00	14.05	600 [283]	71	
			2	17,700 [5.2]	6,900 [2.0]				800 [378]	74	
		RGPR-05?BMK?	1	13,650 [4.0]	5,050 [1.5]	24,600 [7.2]	17.50	13.80	600 [283]	71	
			2	17,700 [5.2]	6,900 [2.0]				775 [366]	74	
		RGPR-07?AMK?	1	13,700 [4.0]	5,100 [1.5]	24,600 [7.2]	18.00	13.95	600 [283]	71	
			2	17,700 [5.2]	6,900 [2.0]				800 [378]	74	
		RCFN-H*2421A*+RXMD-C06	Coil Only	1	13,250 [3.9]	4,950 [1.5]	24,000 [7.0]	15.50	12.55	600 [283]	71
				2	17,250 [5.1]	6,750 [2.0]				775 [366]	74
RCQD-2417A*	RBHM-17J*	1	14,150 [4.1]	4,550 [1.3]	24,600 [7.2]	16.50	12.95	600 [283]	71		
		2	18,750 [5.5]	5,850 [1.7]				825 [389]	74		
	RGFD-06?MCK?	1	14,150 [4.1]	4,550 [1.3]	24,600 [7.2]	16.50	12.80	600 [283]	71		
		2	18,750 [5.5]	5,850 [1.7]				800 [378]	74		
	RGFD-07?MCK?	1	14,150 [4.1]	4,550 [1.3]	24,600 [7.2]	16.50	12.90	600 [283]	71		
		2	18,750 [5.5]	5,850 [1.7]				800 [378]	74		
	RGJD-06?MCK?	1	14,100 [4.1]	4,600 [1.3]	24,800 [7.3]	16.50	13.10	600 [283]	71		
		2	18,900 [5.5]	5,900 [1.7]				800 [378]	74		
	RGJD-07?MCK?	1	14,150 [4.1]	4,550 [1.3]	24,600 [7.2]	16.50	13.00	625 [295]	71		
		2	18,750 [5.5]	5,850 [1.7]				800 [378]	74		
	RGPR-05?BMK?	1	14,050 [4.1]	4,550 [1.3]	24,800 [7.3]	16.50	13.05	600 [283]	71		
		2	18,950 [5.6]	5,850 [1.7]				775 [366]	74		
	RGPR-07?AMK?	1	14,100 [4.1]	4,600 [1.3]	24,800 [7.3]	17.00	13.20	600 [283]	71		
		2	18,900 [5.5]	5,900 [1.7]				800 [378]	74		

① Highest sales volume tested combination required by DOE test procedures.

[ ] Designates Metric Conversions

# Performance Data @ ARI Standard Conditions—Cooling

Outdoor Unit RASL-	Model Numbers		Stage	ARI Cooling Performance 80°F [26.5°C] DB / 67°F [19.5°C] WB Indoor Air 95°F [35°C] DB Outdoor Air						
				Net Sensible BTU/H [kW]	Net Latent BTU/H [kW]	ARI Ratings			Indoor Airflow CFM [L/s]	Sound Rating db
	Total Capacity BTU/H [kW]	SEER				EER				
REV. 10/8/2008 024JEC	RCQD-2417A*+RXMD-C06	Coil Only	1	13,750 [4.0]	4,450 [1.3]	24,200 [7.1]	14.50	11.85	600 [283]	71
			2	18,450 [5.4]	5,750 [1.7]				800 [378]	74
	RCSM-H*2421A*	RHPL-HM2421	1	13,400 [3.9]	5,200 [1.5]	24,600 [7.2]	16.50	13.30	600 [283]	71
			2	17,600 [5.2]	7,000 [2.1]				800 [378]	74
036JEC	RCSN-H*3624A* ①	RHPN-HM3624	1	20,450 [6.0]	6,150 [1.8]	37,000 [10.8]	18.00	13.80	950 [448]	69
			2	26,750 [7.8]	10,250 [3.0]				1175 [554]	72
			1 - dehumid	18,900 [5.5]	6,900 [2.0]				800 [378]	69
			2 - dehumid	24,550 [7.2]	11,050 [3.2]				975 [460]	72
	RCFM-H*3617A*	Coil Only	1	16,700 [4.9]	7,100 [2.1]	33,600 [9.8]	14.00	11.20	900 [425]	69
			2	22,450 [6.6]	11,150 [3.3]				1075 [507]	72
		RGFD-06?MCK?	1	17,000 [5.0]	7,200 [2.1]	33,400 [9.8]	14.50	11.00	875 [413]	69
			2	22,300 [6.5]	11,100 [3.3]				1175 [554]	72
		RGFD-07?MCK?	1	17,000 [5.0]	7,200 [2.1]	33,400 [9.8]	14.50	10.90	900 [425]	69
			2	22,300 [6.5]	11,100 [3.3]				1200 [566]	72
		RGGD-06?MCK?	1	16,950 [5.0]	7,250 [2.1]	33,400 [9.8]	15.00	11.05	900 [425]	69
			2	22,300 [6.5]	11,100 [3.3]				1225 [578]	72
		RGGD-07?MCK?	1	16,950 [5.0]	7,250 [2.1]	33,400 [9.8]	14.50	10.95	925 [437]	69
			2	22,300 [6.5]	11,100 [3.3]				1225 [578]	72
		RGJD-06?MCK?	1	16,950 [5.0]	7,250 [2.1]	33,400 [9.8]	15.00	11.05	900 [425]	69
			2	22,300 [6.5]	11,100 [3.3]				1225 [578]	72
		RGJD-07?MCK?	1	16,950 [5.0]	7,250 [2.1]	33,400 [9.8]	14.50	10.95	925 [437]	69
			2	22,300 [6.5]	11,100 [3.3]				1225 [578]	72
		RGLR-07?AMK?	1	17,150 [5.0]	7,250 [2.1]	33,800 [9.9]	15.00	11.50	925 [437]	69
			2	22,600 [6.6]	11,200 [3.3]				1200 [566]	72
		RGPR-05?BMK?	1	17,000 [5.0]	7,200 [2.1]	33,400 [9.8]	14.50	11.00	900 [425]	69
			2	22,300 [6.5]	11,100 [3.3]				1200 [566]	72
		RGPR-07?AMK?	1	17,150 [5.0]	7,250 [2.1]	33,800 [9.9]	15.00	11.40	900 [425]	69
			2	22,600 [6.6]	11,200 [3.3]				1200 [566]	72
	RCFM-H*3621A*	Coil Only	1	16,950 [5.0]	7,050 [2.1]	33,600 [9.8]	14.00	11.20	900 [425]	69
			2	22,550 [6.6]	11,050 [3.2]				1150 [543]	72
		RGFD-06?MCK?	1	17,250 [5.1]	7,150 [2.1]	33,600 [9.8]	14.50	11.05	875 [413]	69
			2	22,600 [6.6]	11,000 [3.2]				1175 [554]	72
		RGFD-07?MCK?	1	17,250 [5.1]	7,150 [2.1]	33,400 [9.8]	14.50	10.95	900 [425]	69
			2	22,400 [6.6]	11,000 [3.2]				1200 [566]	72
		RGFD-09?ZCM?	1	17,250 [5.1]	7,150 [2.1]	33,800 [9.9]	15.50	12.00	850 [401]	69
			2	22,700 [6.7]	11,100 [3.3]				1150 [543]	72
		RGFD-10?ZCM?	1	17,250 [5.1]	7,150 [2.1]	34,000 [10.0]	15.50	11.70	850 [401]	69
			2	22,850 [6.7]	11,150 [3.3]				1175 [554]	72
		RGGD-06?MCK?	1	17,200 [5.0]	7,200 [2.1]	33,600 [9.8]	15.00	11.10	900 [425]	69
			2	22,550 [6.6]	11,050 [3.2]				1225 [578]	72
		RGGD-07?MCK?	1	17,200 [5.0]	7,200 [2.1]	33,400 [9.8]	15.00	11.00	925 [437]	69
			2	22,400 [6.6]	11,000 [3.2]				1225 [578]	72
		RGGD-09?ZCM?	1	17,100 [5.0]	7,100 [2.1]	34,000 [10.0]	15.50	12.00	800 [378]	69
			2	22,800 [6.7]	11,200 [3.3]				1175 [554]	72
		RGGD-10?ZCM?	1	17,250 [5.1]	7,150 [2.1]	34,000 [10.0]	15.50	12.00	825 [389]	69
			2	22,800 [6.7]	11,200 [3.3]				1175 [554]	72
		RGJD-06?MCK?	1	17,200 [5.0]	7,200 [2.1]	33,600 [9.8]	15.00	11.10	900 [425]	69
			2	22,550 [6.6]	11,050 [3.2]				1225 [578]	72
	RGJD-07?MCK?	1	17,200 [5.0]	7,200 [2.1]	33,400 [9.8]	15.00	11.00	925 [437]	69	
		2	22,400 [6.6]	11,000 [3.2]				1225 [578]	72	
	RGJD-09?ZCM?	1	17,100 [5.0]	7,100 [2.1]	34,000 [10.0]	15.50	12.00	800 [378]	69	
		2	22,800 [6.7]	11,200 [3.3]				1175 [554]	72	
RGJD-10?ZCM?	1	17,250 [5.1]	7,150 [2.1]	34,000 [10.0]	15.50	12.00	825 [389]	69		
	2	22,800 [6.7]	11,200 [3.3]				1175 [554]	72		

① Highest sales volume tested combination required by DOE test procedures.

[ ] Designates Metric Conversions



# Performance Data @ ARI Standard Conditions—Cooling

Outdoor Unit RASL-	Model Numbers		Stage	ARI Cooling Performance 80°F [26.5°C] DB / 67°F [19.5°C] WB Indoor Air 95°F [35°C] DB Outdoor Air						Indoor Airflow CFM [L/s]	Sound Rating db		
				Net Sensible BTU/H [kW]	Net Latent BTU/H [kW]	ARI Ratings							
	ID Coil	ID Air Mover				Total Capacity BTU/H [kW]	SEER	EER					
REV. 10/8/2008	RCFM-H*3621A*		1	17,400 [5.1]	7,200 [2.1]	33,800 [9.9]	15.50	11.55	925 [437]	69			
				22,650 [6.6]	11,150 [3.3]				1200 [566]	72			
			1	17,350 [5.1]	7,250 [2.1]	34,200 [10.0]	15.50	12.00	900 [425]	69			
				23,000 [6.7]	11,200 [3.3]				1225 [578]	72			
			1	17,350 [5.1]	7,250 [2.1]	34,200 [10.0]	15.50	12.00	925 [437]	69			
				22,950 [6.7]	11,250 [3.3]				1200 [566]	72			
			1	17,250 [5.1]	7,150 [2.1]	33,600 [9.8]	14.50	11.05	900 [425]	69			
				22,600 [6.6]	11,000 [3.2]				1200 [566]	72			
			1	17,400 [5.1]	7,200 [2.1]	33,800 [9.9]	15.00	11.50	900 [425]	69			
				22,700 [6.7]	11,100 [3.3]				1200 [566]	72			
			1	17,550 [5.1]	7,250 [2.1]	34,200 [10.0]	16.00	12.05	875 [413]	69			
				22,950 [6.7]	11,250 [3.3]				1200 [566]	72			
			1	17,350 [5.1]	7,250 [2.1]	34,000 [10.0]	15.50	12.00	925 [437]	69			
				22,800 [6.7]	11,200 [3.3]				1225 [578]	72			
			036JEC	RCFN-H*3624A*		Coil Only	19,850 [5.8]	5,950 [1.7]	36,200 [10.6]	15.00	12.30	950 [448]	69
							26,200 [7.7]	10,000 [2.9]				1175 [554]	72
						1	20,000 [5.9]	6,000 [1.8]	36,800 [10.8]	17.50	13.35	850 [401]	69
							26,600 [7.8]	10,200 [3.0]				1150 [543]	72
						1	20,000 [5.9]	6,000 [1.8]	36,600 [10.7]	17.00	13.15	850 [401]	69
							26,450 [7.7]	10,150 [3.0]				1175 [554]	72
1	20,150 [5.9]	6,050 [1.8]				37,000 [10.8]	17.50	13.30	900 [425]	69			
	26,750 [7.8]	10,250 [3.0]							1225 [578]	72			
1	19,850 [5.8]	5,950 [1.7]				36,800 [10.8]	17.50	13.30	800 [378]	69			
	26,600 [7.8]	10,200 [3.0]							1175 [554]	72			
1	19,800 [5.8]	6,000 [1.8]				36,800 [10.8]	17.50	13.30	825 [389]	69			
	26,600 [7.8]	10,200 [3.0]							1175 [554]	72			
1	20,150 [5.9]	6,050 [1.8]				37,000 [10.8]	17.50	13.50	900 [425]	69			
	26,750 [7.8]	10,250 [3.0]							1225 [578]	72			
1	19,850 [5.8]	5,950 [1.7]				36,800 [10.8]	17.50	13.30	800 [378]	69			
	26,600 [7.8]	10,200 [3.0]							1175 [554]	72			
1	19,800 [5.8]	6,000 [1.8]				36,800 [10.8]	17.50	13.30	825 [389]	69			
	26,600 [7.8]	10,200 [3.0]							1175 [554]	72			
1	20,150 [5.9]	6,050 [1.8]				37,000 [10.8]	17.50	13.50	900 [425]	69			
	26,750 [7.8]	10,250 [3.0]							1225 [578]	72			
1	20,150 [5.9]	6,050 [1.8]	37,000 [10.8]	17.50	13.50	900 [425]	69						
	26,750 [7.8]	10,250 [3.0]				1225 [578]	72						
1	20,450 [6.0]	6,150 [1.8]	36,800 [10.8]	17.50	13.50	925 [437]	69						
	26,600 [7.8]	10,200 [3.0]				1200 [566]	72						
1	20,600 [6.0]	6,200 [1.8]	37,200 [10.9]	18.00	13.60	1000 [472]	69						
	26,900 [7.9]	10,300 [3.0]				1225 [578]	72						
1	20,150 [5.9]	6,050 [1.8]	36,800 [10.8]	17.50	13.50	875 [413]	69						
	26,600 [7.8]	10,200 [3.0]				1200 [566]	72						
1	20,300 [5.9]	6,100 [1.8]	37,000 [10.8]	17.50	13.35	925 [437]	69						
	26,750 [7.8]	10,250 [3.0]				1225 [578]	72						
1	20,450 [6.0]	6,150 [1.8]	37,200 [10.9]	17.50	13.50	1000 [472]	69						
	26,900 [7.9]	10,300 [3.0]				1250 [590]	72						
RCQD-3621A*			1	19,650 [5.8]	6,150 [1.8]	36,800 [10.8]	16.00	12.05	875 [413]	69			
				27,100 [7.9]	9,700 [2.8]				1175 [554]	72			
			1	19,800 [5.8]	6,200 [1.8]	37,000 [10.8]	16.00	12.05	900 [425]	69			
				27,250 [8.0]	9,750 [2.9]				1200 [566]	72			
			1	19,650 [5.8]	6,150 [1.8]	37,400 [11.0]	17.00	12.95	850 [401]	69			
				27,550 [8.1]	9,850 [2.9]				1150 [543]	72			
			1	19,650 [5.8]	6,150 [1.8]	37,200 [10.9]	17.00	12.75	850 [401]	69			
				27,400 [8.0]	9,800 [2.9]				1175 [554]	72			

① Highest sales volume tested combination required by DOE test procedures.

[ ] Designates Metric Conversions

# Performance Data @ ARI Standard Conditions—Cooling

Outdoor Unit RASL-	Model Numbers		Stage	ARI Cooling Performance 80°F [26.5°C] DB / 67°F [19.5°C] WB Indoor Air 95°F [35°C] DB Outdoor Air							
				Net Sensible BTU/H [kW]	Net Latent BTU/H [kW]	ARI Ratings			Indoor Airflow CFM [L/s]	Sound Rating db	
	Total Capacity BTU/H [kW]	SEER				EER					
	ID Coil	ID Air Mover									
REV. 10/8/2008	RCQD-3621A*	RGJD-06?MCK?	1	19,950 [5.8]	6,250 [1.8]	37,400 [11.0]	16.50	12.30	900 [425]	69	
			2	27,550 [8.1]	9,850 [2.9]				1225 [578]	72	
		RGJD-07?MCK?	1	19,800 [5.8]	6,200 [1.8]	37,200 [10.9]	16.50	12.15	925 [437]	69	
			2	27,400 [8.0]	9,800 [2.9]				1225 [578]	72	
		RGJD-09?ZCM?	1	19,450 [5.7]	6,150 [1.8]	37,400 [11.0]	17.00	12.95	800 [378]	69	
			2	27,550 [8.1]	9,850 [2.9]				1175 [554]	72	
		RGJD-10?ZCM?	1	19,650 [5.8]	6,150 [1.8]	37,400 [11.0]	17.00	12.95	825 [389]	69	
			2	27,550 [8.1]	9,850 [2.9]				1175 [554]	72	
		RGPR-05?BMK?	1	19,800 [5.8]	6,200 [1.8]	37,200 [10.9]	16.00	12.15	900 [425]	69	
			2	27,400 [8.0]	9,800 [2.9]				1200 [566]	72	
RGPR-07?AMK?		1	19,950 [5.8]	6,250 [1.8]	37,400 [11.0]	17.00	12.65	900 [425]	69		
		2	27,550 [8.1]	9,850 [2.9]				1200 [566]	72		
RGPR-07?BRQ?		1	19,800 [5.8]	6,200 [1.8]	37,800 [11.1]	17.00	13.20	875 [413]	69		
		2	27,850 [8.2]	9,950 [2.9]				1200 [566]	72		
RGPR-10?BRM?		1	19,950 [5.8]	6,250 [1.8]	37,800 [11.1]	17.00	13.00	925 [437]	69		
		2	27,850 [8.2]	9,950 [2.9]				1225 [578]	72		
RCQD-3621A*+RXMD-C06		Coil Only	1	19,500 [5.7]	6,100 [1.8]	36,800 [10.8]	15.00	12.10	925 [437]	69	
			2	27,100 [7.9]	9,700 [2.8]				1150 [543]	72	
036JEC	RCQD-3624A*	RBHM-24J*	1	20,100 [5.9]	6,300 [1.8]	38,000 [11.1]	17.50	13.55	900 [425]	69	
			2	28,000 [8.2]	10,000 [2.9]				1200 [566]	72	
		RBHN-24J*	1	20,100 [5.9]	6,300 [1.8]	38,000 [11.1]	17.50	13.90	925 [437]	69	
			2	28,000 [8.2]	10,000 [2.9]				1175 [554]	72	
		RGFD-09?ZCM?	1	19,650 [5.8]	6,150 [1.8]	37,400 [11.0]	17.00	13.00	850 [401]	69	
			2	27,550 [8.1]	9,850 [2.9]				1150 [543]	72	
		RGFD-10?ZCM?	1	19,650 [5.8]	6,150 [1.8]	37,400 [11.0]	17.00	12.85	850 [401]	69	
			2	27,550 [8.1]	9,850 [2.9]				1175 [554]	72	
		RGFD-12?RCM?	1	19,950 [5.8]	6,250 [1.8]	37,800 [11.1]	17.00	13.05	900 [425]	69	
			2	27,850 [8.2]	9,950 [2.9]				1225 [578]	72	
		RGJD-09?ZCM?	1	19,450 [5.7]	6,150 [1.8]	37,400 [11.0]	17.00	13.00	800 [378]	69	
			2	27,550 [8.1]	9,850 [2.9]				1175 [554]	72	
		RGJD-10?ZCM?	1	19,650 [5.8]	6,150 [1.8]	37,400 [11.0]	17.00	13.00	825 [389]	69	
			2	27,550 [8.1]	9,850 [2.9]				1175 [554]	72	
		RGJD-12?RCM?	1	19,950 [5.8]	6,250 [1.8]	38,000 [11.1]	17.00	13.20	900 [425]	69	
			2	28,000 [8.2]	10,000 [2.9]				1225 [578]	72	
		RGPR-07?BRQ?	1	19,800 [5.8]	6,200 [1.8]	37,800 [11.1]	17.50	13.25	875 [413]	69	
			2	27,850 [8.2]	9,950 [2.9]				1200 [566]	72	
		RGPR-10?BRM?	1	19,950 [5.8]	6,250 [1.8]	37,800 [11.1]	17.00	13.10	925 [437]	69	
			2	27,850 [8.2]	9,950 [2.9]				1225 [578]	72	
		RGPR-12?ARM?	1	20,250 [5.9]	6,350 [1.9]	38,000 [11.1]	17.00	13.20	1000 [472]	69	
			2	28,000 [8.2]	10,000 [2.9]				1250 [590]	72	
		RCQD-3624A*+RXMD-C06	Coil Only	1	19,500 [5.7]	6,100 [1.8]	36,800 [10.8]	15.00	12.10	925 [437]	69
				2	27,100 [7.9]	9,700 [2.8]				1150 [543]	72
RCSM-H*3621A*	RHPL-HM3621	1	17,350 [5.1]	7,250 [2.1]	34,200 [10.0]	16.00	12.10	925 [437]	69		
		2	22,950 [6.7]	11,250 [3.3]				1225 [578]	72		
039JEC	RCSN-H*3624A* ①	RHPN-HM3624	1	17,100 [5.0]	4,700 [1.4]	39,500 [11.6]	19.50	13.85	825 [389]	69	
			2	28,000 [8.2]	11,600 [3.4]				1175 [554]	73	
			1 - dehumid	17,150 [5.0]	5,050 [1.5]				725 [342]	69	
			2 - dehumid	26,250 [7.7]	12,350 [3.6]				975 [460]	73	
	RCFM-H*3617A*	Coil Only	1	14,100 [4.1]	5,400 [1.6]	35,600 [10.4]	14.00	11.35	800 [378]	69	
			2	23,400 [6.9]	12,200 [3.6]				1075 [507]	73	
		RGFD-06?MCK?	1	14,450 [4.2]	5,550 [1.6]	35,400 [10.4]	15.00	11.15	875 [413]	69	
			2	23,250 [6.8]	12,150 [3.6]				1175 [554]	73	
		RGFD-07?MCK?	1	14,600 [4.3]	5,600 [1.6]	35,400 [10.4]	15.00	11.05	900 [425]	69	
			2	23,250 [6.8]	12,150 [3.6]				1200 [566]	73	

① Highest sales volume tested combination required by DOE test procedures.

[ ] Designates Metric Conversions



# Performance Data @ ARI Standard Conditions—Cooling

Outdoor Unit RASL-	Model Numbers		Stage	ARI Cooling Performance 80°F [26.5°C] DB / 67°F [19.5°C] WB Indoor Air 95°F [35°C] DB Outdoor Air							
				Net Sensible BTU/H [kW]	Net Latent BTU/H [kW]	ARI Ratings			Indoor Airflow CFM [L/s]	Sound Rating db	
	ID Coil	ID Air Mover				Total Capacity BTU/H [kW]	SEER	EER			
REV. 10/8/2008	RCFM-H*3617A*		1	14,800 [4.3]	5,600 [1.6]	35,400 [10.4]	15.50	11.20	900 [425]	69	
				23,250 [6.8]	12,150 [3.6]				1225 [578]	73	
			1	14,750 [4.3]	5,650 [1.7]	35,400 [10.4]	15.00	11.10	925 [437]	69	
				23,250 [6.8]	12,150 [3.6]				1225 [578]	73	
			1	14,800 [4.3]	5,600 [1.6]	35,400 [10.4]	15.50	11.20	900 [425]	69	
				23,250 [6.8]	12,150 [3.6]				1225 [578]	73	
			1	14,750 [4.3]	5,650 [1.7]	35,400 [10.4]	15.00	11.10	925 [437]	69	
				23,250 [6.8]	12,150 [3.6]				1225 [578]	73	
			1	14,900 [4.4]	5,700 [1.7]	35,800 [10.5]	16.00	11.65	925 [437]	69	
				23,550 [6.9]	12,250 [3.6]				1200 [566]	73	
			1	14,600 [4.3]	5,600 [1.6]	35,400 [10.4]	15.00	11.15	900 [425]	69	
				23,250 [6.8]	12,150 [3.6]				1200 [566]	73	
			1	14,750 [4.3]	5,650 [1.7]	35,800 [10.5]	15.50	11.55	900 [425]	69	
				23,550 [6.9]	12,250 [3.6]				1200 [566]	73	
	039JEC	Coil Only		1	14,100 [4.1]	5,400 [1.6]	35,600 [10.4]	14.00	11.35	875 [413]	69
					23,400 [6.9]	12,200 [3.6]				1150 [543]	73
		1	14,300 [4.2]	5,500 [1.6]	35,600 [10.4]	15.00	11.20	875 [413]	69		
			23,450 [6.9]	12,150 [3.6]				1175 [554]	73		
		1	14,400 [4.2]	5,500 [1.6]	35,400 [10.4]	15.50	11.10	900 [425]	69		
			23,250 [6.8]	12,150 [3.6]				1200 [566]	73		
1		14,650 [4.3]	5,550 [1.6]	35,800 [10.5]	16.50	11.90	850 [401]	69			
		23,550 [6.9]	12,250 [3.6]				1150 [543]	73			
1		14,650 [4.3]	5,550 [1.6]	36,000 [10.5]	16.50	11.85	850 [401]	69			
		23,700 [6.9]	12,300 [3.6]				1175 [554]	73			
1		14,450 [4.2]	5,550 [1.6]	35,600 [10.4]	15.50	11.25	900 [425]	69			
		23,400 [6.9]	12,200 [3.6]				1225 [578]	73			
1		14,650 [4.3]	5,550 [1.6]	35,400 [10.4]	15.50	11.15	925 [437]	69			
		23,250 [6.8]	12,150 [3.6]				1225 [578]	73			
1		14,400 [4.2]	5,500 [1.6]	36,000 [10.5]	16.50	12.00	800 [378]	69			
		23,650 [6.9]	12,350 [3.6]				1175 [554]	73			
1		14,450 [4.2]	5,550 [1.6]	36,000 [10.5]	16.50	12.05	825 [389]	69			
		23,650 [6.9]	12,350 [3.6]				1175 [554]	73			
1		14,450 [4.2]	5,550 [1.6]	35,600 [10.4]	15.50	11.25	900 [425]	69			
		23,400 [6.9]	12,200 [3.6]				1225 [578]	73			
1	14,650 [4.3]	5,550 [1.6]	35,400 [10.4]	15.50	11.15	925 [437]	69				
	23,250 [6.8]	12,150 [3.6]				1225 [578]	73				
1	14,400 [4.2]	5,500 [1.6]	36,000 [10.5]	16.50	12.00	800 [378]	69				
	23,650 [6.9]	12,350 [3.6]				1175 [554]	73				
1	14,450 [4.2]	5,550 [1.6]	36,000 [10.5]	16.50	12.05	825 [389]	69				
	23,650 [6.9]	12,350 [3.6]				1175 [554]	73				
1	14,600 [4.3]	5,600 [1.6]	35,800 [10.5]	16.00	11.70	925 [437]	69				
	23,500 [6.9]	12,300 [3.6]				1200 [566]	73				
1	14,600 [4.3]	5,600 [1.6]	36,200 [10.6]	16.50	12.05	900 [425]	69				
	23,850 [7.0]	12,350 [3.6]				1225 [578]	73				
1	14,750 [4.3]	5,650 [1.7]	36,200 [10.6]	16.50	12.15	925 [437]	69				
	23,800 [7.0]	12,400 [3.6]				1200 [566]	73				
1	14,300 [4.2]	5,500 [1.6]	35,600 [10.4]	15.00	11.20	900 [425]	69				
	23,450 [6.9]	12,150 [3.6]				1200 [566]	73				
1	14,450 [4.2]	5,550 [1.6]	35,800 [10.5]	16.00	11.60	900 [425]	69				
	23,550 [6.9]	12,250 [3.6]				1200 [566]	73				
1	14,600 [4.3]	5,600 [1.6]	36,200 [10.6]	16.50	12.15	875 [413]	69				
	23,800 [7.0]	12,400 [3.6]				1200 [566]	73				
1	14,600 [4.3]	5,600 [1.6]	36,000 [10.5]	16.50	11.90	925 [437]	69				
	23,650 [6.9]	12,350 [3.6]				1225 [578]	73				

① Highest sales volume tested combination required by DOE test procedures.

[ ] Designates Metric Conversions

# Performance Data @ ARI Standard Conditions—Cooling

Outdoor Unit RASL-	Model Numbers		Stage	ARI Cooling Performance 80°F [26.5°C] DB / 67°F [19.5°C] WB Indoor Air 95°F [35°C] DB Outdoor Air						
				Net Sensible BTU/H [kW]	Net Latent BTU/H [kW]	ARI Ratings			Indoor Airflow CFM [L/s]	Sound Rating db
	Total Capacity BTU/H [kW]	SEER				EER				
REV. 10/8/2008	RCFN-H*3624A*	Coil Only	1	16,800 [4.9]	4,400 [1.3]	38,500 [11.3]	15.50	12.40	875 [413]	69
			2	27,300 [8.0]	11,300 [3.3]				1175 [554]	73
		RGFD-09?ZCM?	1	16,950 [5.0]	4,650 [1.4]	39,000 [11.4]	18.00	13.40	850 [401]	69
			2	27,700 [8.1]	11,500 [3.4]				1150 [543]	73
		RGFD-10?ZCM?	1	16,950 [5.0]	4,650 [1.4]	39,000 [11.4]	18.00	13.20	850 [401]	69
			2	27,750 [8.1]	11,450 [3.4]				1175 [554]	73
		RGFD-12?RCM?	1	17,250 [5.1]	4,750 [1.4]	39,500 [11.6]	18.50	13.35	900 [425]	69
			2	28,050 [8.2]	11,550 [3.4]				1225 [578]	73
		RGGD-09?ZCM?	1	16,950 [5.0]	4,650 [1.4]	39,000 [11.4]	18.50	13.35	800 [378]	69
			2	27,700 [8.1]	11,500 [3.4]				1175 [554]	73
		RGGD-10?ZCM?	1	16,950 [5.0]	4,650 [1.4]	39,000 [11.4]	18.50	13.35	825 [389]	69
			2	27,700 [8.1]	11,500 [3.4]				1175 [554]	73
		RGGD-12?RCM?	1	17,250 [5.1]	4,750 [1.4]	39,500 [11.6]	18.50	13.50	900 [425]	69
			2	28,000 [8.2]	11,600 [3.4]				1225 [578]	73
		RGJD-09?ZCM?	1	16,950 [5.0]	4,650 [1.4]	39,000 [11.4]	18.50	13.35	800 [378]	69
			2	27,700 [8.1]	11,500 [3.4]				1175 [554]	73
		RGJD-10?ZCM?	1	16,950 [5.0]	4,650 [1.4]	39,000 [11.4]	18.50	13.35	825 [389]	69
			2	27,700 [8.1]	11,500 [3.4]				1175 [554]	73
		RGJD-12?RCM?	1	17,250 [5.1]	4,750 [1.4]	39,500 [11.6]	18.50	13.50	900 [425]	69
			2	28,000 [8.2]	11,600 [3.4]				1225 [578]	73
RGLR-07?BRQ?	1	17,250 [5.1]	4,750 [1.4]	39,500 [11.6]	18.50	13.55	900 [425]	69		
	2	28,000 [8.2]	11,600 [3.4]				1225 [578]	73		
RGLR-10?BRM?	1	17,250 [5.1]	4,750 [1.4]	39,500 [11.6]	18.50	13.50	925 [437]	69		
	2	27,900 [8.2]	11,500 [3.4]				1200 [566]	73		
RGLR-12?ARM?	1	17,550 [5.1]	4,850 [1.4]	39,500 [11.6]	19.00	13.65	1000 [472]	69		
	2	28,000 [8.2]	11,600 [3.4]				1225 [578]	73		
RGPR-07?BRQ?	1	17,100 [5.0]	4,700 [1.4]	39,500 [11.6]	18.50	13.50	875 [413]	69		
	2	27,850 [8.2]	11,550 [3.4]				1200 [566]	73		
RGPR-10?BRM?	1	17,250 [5.1]	4,750 [1.4]	39,500 [11.6]	18.50	13.40	925 [437]	69		
	2	28,000 [8.2]	11,600 [3.4]				1225 [578]	73		
RGPR-12?ARM?	1	17,550 [5.1]	4,850 [1.4]	40,000 [11.7]	18.50	18.50	1000 [472]	69		
	2	28,150 [8.2]	11,650 [3.4]				1250 [590]	73		
039JEC	RCQD-3621A*	Coil Only	1	15,850 [4.6]	4,550 [1.3]	37,400 [11.0]	14.50	11.95	800 [378]	69
			2	26,700 [7.8]	10,700 [3.1]				1200 [566]	73
		RGFD-06?MCK?	1	16,300 [4.8]	4,700 [1.4]	37,400 [11.0]	16.00	12.00	875 [413]	69
			2	26,700 [7.8]	10,700 [3.1]				1175 [554]	73
		RGFD-07?MCK?	1	16,450 [4.8]	4,750 [1.4]	37,400 [11.0]	16.00	11.90	900 [425]	69
			2	26,700 [7.8]	10,700 [3.1]				1200 [566]	73
		RGFD-09?ZCM?	1	16,450 [4.8]	4,750 [1.4]	37,800 [11.1]	17.00	12.75	850 [401]	69
			2	27,000 [7.9]	10,800 [3.2]				1150 [543]	73
		RGFD-10?ZCM?	1	16,450 [4.8]	4,750 [1.4]	37,800 [11.1]	17.00	12.70	850 [401]	69
			2	26,950 [7.9]	10,850 [3.2]				1175 [554]	73
		RGJD-06?MCK?	1	16,650 [4.9]	4,750 [1.4]	37,600 [11.0]	16.50	12.10	900 [425]	69
			2	26,850 [7.9]	10,750 [3.1]				1225 [578]	73
		RGJD-07?MCK?	1	16,650 [4.9]	4,750 [1.4]	37,400 [11.0]	16.00	12.00	925 [437]	69
			2	26,700 [7.8]	10,700 [3.1]				1225 [578]	73
		RGJD-09?ZCM?	1	16,300 [4.8]	4,700 [1.4]	38,000 [11.1]	17.00	12.85	800 [378]	69
			2	27,150 [8.0]	10,850 [3.2]				1175 [554]	73
		RGJD-10?ZCM?	1	16,300 [4.8]	4,700 [1.4]	38,000 [11.1]	17.00	12.85	825 [389]	69
			2	27,150 [8.0]	10,850 [3.2]				1175 [554]	73
		RGPR-05?BMK?	1	16,450 [4.8]	4,750 [1.4]	37,400 [11.0]	16.00	12.05	900 [425]	69
			2	26,700 [7.8]	10,700 [3.1]				1200 [566]	73
RGPR-07?AMK?	1	16,650 [4.9]	4,750 [1.4]	37,800 [11.1]	16.50	12.45	900 [425]	69		
	2	27,000 [7.9]	10,800 [3.2]				1200 [566]	73		

① Highest sales volume tested combination required by DOE test procedures.

[ ] Designates Metric Conversions

# Performance Data @ ARI Standard Conditions—Cooling

Outdoor Unit RASL-	Model Numbers		Stage	ARI Cooling Performance 80°F [26.5°C] DB / 67°F [19.5°C] WB Indoor Air 95°F [35°C] DB Outdoor Air							
				Net Sensible BTU/H [kW]	Net Latent BTU/H [kW]	ARI Ratings			Indoor Airflow CFM [L/s]	Sound Rating db	
	ID Coil	ID Air Mover				Total Capacity BTU/H [kW]	SEER	EER			
REV. 10/8/2008	RCQD-3621A*	RGPR-07?BRQ?	1	16,650 [4.9]	4,750 [1.4]	38,000 [11.1]	17.50	13.00	875 [413]	69	
			2	27,100 [7.9]	10,900 [3.2]				1200 [566]	73	
RGPR-10?BRM?		1	16,800 [4.9]	4,800 [1.4]	38,000 [11.1]	17.00	12.80	925 [437]	69		
		2	27,150 [8.0]	10,850 [3.2]				1225 [578]	73		
039JEC	RCQD-3624A*	Coil Only	1	15,850 [4.6]	4,550 [1.3]	37,400 [11.0]	14.50	11.95	800 [378]	69	
			2	26,700 [7.8]	10,700 [3.1]				1200 [566]	73	
		RBHM-24J*	1	16,800 [4.9]	4,800 [1.4]	38,500 [11.3]	17.50	13.40	900 [425]	69	
			2	27,450 [8.0]	10,950 [3.2]				1200 [566]	73	
		RBHN-24J*	1	16,750 [4.9]	4,850 [1.4]	38,500 [11.3]	18.00	13.75	925 [437]	69	
			2	27,550 [8.1]	11,050 [3.2]				1175 [554]	73	
		RGFD-09?ZCM?	1	16,450 [4.8]	4,750 [1.4]	37,800 [11.1]	17.00	12.85	850 [401]	69	
			2	27,000 [7.9]	10,800 [3.2]				1150 [543]	73	
		RGFD-10?ZCM?	1	16,450 [4.8]	4,750 [1.4]	38,000 [11.1]	17.00	12.75	850 [401]	69	
			2	27,150 [8.0]	10,850 [3.2]				1175 [554]	73	
		RGFD-12?RCM?	1	16,600 [4.9]	4,800 [1.4]	38,000 [11.1]	17.00	12.85	900 [425]	69	
			2	27,150 [8.0]	10,850 [3.2]				1225 [578]	73	
		RGJD-09?ZCM?	1	16,300 [4.8]	4,700 [1.4]	38,000 [11.1]	17.00	12.90	800 [378]	69	
			2	27,100 [7.9]	10,900 [3.2]				1175 [554]	73	
		RGJD-10?ZCM?	1	16,300 [4.8]	4,700 [1.4]	38,000 [11.1]	17.00	12.90	825 [389]	69	
			2	27,100 [7.9]	10,900 [3.2]				1175 [554]	73	
		RGJD-12?RCM?	1	16,600 [4.9]	4,800 [1.4]	38,000 [11.1]	17.00	13.00	900 [425]	69	
			2	27,100 [7.9]	10,900 [3.2]				1225 [578]	73	
		RGPR-07?BRQ?	1	16,600 [4.9]	4,800 [1.4]	38,000 [11.1]	17.50	13.10	875 [413]	69	
			2	27,300 [8.0]	10,900 [3.2]				1200 [566]	73	
		RGPR-10?BRM?	1	16,800 [4.9]	4,800 [1.4]	38,000 [11.1]	17.00	12.90	925 [437]	69	
			2	27,100 [7.9]	10,900 [3.2]				1225 [578]	73	
		RGPR-12?ARM?	1	17,100 [5.0]	4,900 [1.4]	38,500 [11.3]	17.00	13.05	1000 [472]	69	
			2	27,450 [8.0]	10,950 [3.2]				1250 [590]	73	
		RCSM-H*3621A*	Coil Only	1	14,100 [4.1]	5,400 [1.6]	35,600 [10.4]	14.00	11.35	875 [413]	69
				2	23,400 [6.9]	12,200 [3.6]				1150 [543]	73
			RHPL-HM3621	1	14,750 [4.3]	5,650 [1.7]	36,200 [10.6]	17.00	12.20	925 [437]	69
				2	23,800 [7.0]	12,400 [3.6]				1225 [578]	73
048JEC	RCSN-H*4824A* ①	RHPN-HM4824	1	20,750 [6.1]	5,850 [1.7]	48,500 [14.2]	18.00	13.00	1000 [472]	73	
			2	35,700 [10.5]	12,700 [3.7]				1600 [755]	74	
			1 - dehumid	19,200 [5.6]	6,800 [2.0]				825 [389]	73	
			2 - dehumid	33,000 [9.7]	14,200 [4.2]				1300 [613]	74	
	RCFM-H*4821A*	Coil Only	1	17,300 [5.1]	7,100 [2.1]	45,000 [13.2]	14.00	11.65	1100 [519]	73	
			2	29,950 [8.8]	15,050 [4.4]				1475 [696]	74	
		RGFD-09?ZCM?	1	17,900 [5.2]	7,300 [2.1]	45,000 [13.2]	15.50	11.45	1150 [543]	73	
			2	29,800 [8.7]	15,000 [4.4]				1600 [755]	74	
		RGFD-10?ZCM?	1	17,900 [5.2]	7,300 [2.1]	44,500 [13.0]	15.00	11.10	1175 [554]	73	
			2	29,700 [8.7]	14,900 [4.4]				1625 [767]	74	
		RGGD-06?MCK?	1	17,300 [5.1]	7,100 [2.1]	43,500 [12.7]	16.00	11.70	900 [425]	73	
			2	29,050 [8.5]	14,550 [4.3]				1225 [578]	74	
		RGGD-07?MCK?	1	17,300 [5.1]	7,100 [2.1]	43,500 [12.7]	16.00	11.60	925 [437]	73	
			2	28,900 [8.5]	14,500 [4.2]				1225 [578]	74	
		RGGD-09?ZCM?	1	17,850 [5.2]	7,350 [2.2]	45,000 [13.2]	15.50	11.20	1175 [554]	73	
			2	30,000 [8.8]	15,000 [4.4]				1675 [790]	74	
		RGGD-10?ZCM?	1	17,850 [5.2]	7,350 [2.2]	44,500 [13.0]	15.50	11.25	1175 [554]	73	
			2	29,650 [8.7]	14,950 [4.4]				1625 [767]	74	
		RGJD-06?MCK?	1	17,300 [5.1]	7,100 [2.1]	43,500 [12.7]	16.00	11.75	900 [425]	73	
			2	29,050 [8.5]	14,550 [4.3]				1225 [578]	74	
		RGJD-07?MCK?	1	17,300 [5.1]	7,100 [2.1]	43,500 [12.7]	16.00	11.65	925 [437]	73	
			2	28,850 [8.5]	14,550 [4.3]				1225 [578]	74	

① Highest sales volume tested combination required by DOE test procedures.

[ ] Designates Metric Conversions

# Performance Data @ ARI Standard Conditions—Cooling

Outdoor Unit RASL-	Model Numbers		Stage	ARI Cooling Performance 80°F [26.5°C] DB / 67°F [19.5°C] WB Indoor Air 95°F [35°C] DB Outdoor Air							
				Net Sensible BTU/H [kW]	Net Latent BTU/H [kW]	ARI Ratings			Indoor Airflow CFM [L/s]	Sound Rating db	
	Total Capacity BTU/H [kW]	SEER				EER					
REV. 10/8/2008	RCFM-H*4821A*	RGJD-09?ZCM?	1	17,850 [5.2]	7,350 [2.2]	45,000 [13.2]	15.50	11.25	1175 [554]	73	
			2	29,950 [8.8]	15,050 [4.4]				1675 [790]	74	
		RGJD-10?ZCM?	1	17,850 [5.2]	7,350 [2.2]	44,500 [13.0]	15.50	11.30	1175 [554]	73	
			2	29,650 [8.7]	14,950 [4.4]				1625 [767]	74	
		RGLR-07?BRQ?	1	18,000 [5.3]	7,400 [2.2]	45,000 [13.2]	16.00	11.80	1225 [578]	73	
			2	30,100 [8.8]	15,100 [4.4]				1625 [767]	74	
		RGLR-10?BRM?	1	18,000 [5.3]	7,400 [2.2]	45,000 [13.2]	16.00	11.90	1200 [566]	73	
			2	30,050 [8.8]	15,150 [4.4]				1575 [743]	74	
		RGPR-07?BRQ?	1	18,150 [5.3]	7,450 [2.2]	45,000 [13.2]	16.00	11.90	1225 [578]	73	
			2	30,100 [8.8]	15,100 [4.4]				1625 [767]	74	
		RGPR-10?BRM?	1	18,050 [5.3]	7,350 [2.2]	45,000 [13.2]	15.50	11.60	1200 [566]	73	
			2	29,950 [8.8]	15,050 [4.4]				1625 [767]	74	
	048JEC	RCFM-H*4824A*	Coil Only	1	17,800 [5.2]	6,800 [2.0]	45,000 [13.2]	14.50	11.65	1100 [519]	73
				2	30,350 [8.9]	14,650 [4.3]				1475 [696]	74
			RGFD-09?ZCM?	1	18,400 [5.4]	7,000 [2.1]	45,000 [13.2]	15.50	11.45	1150 [543]	73
				2	30,200 [8.8]	14,600 [4.3]				1600 [755]	74
			RGFD-10?ZCM?	1	18,400 [5.4]	7,000 [2.1]	44,500 [13.0]	15.50	11.10	1175 [554]	73
				2	30,100 [8.8]	14,500 [4.2]				1625 [767]	74
RGFD-12?RCM?			1	18,550 [5.4]	7,050 [2.1]	45,500 [13.3]	16.00	11.80	1225 [578]	73	
			2	30,650 [9.0]	14,750 [4.3]				1650 [779]	74	
RGGD-09?ZCM?			1	18,400 [5.4]	7,000 [2.1]	45,000 [13.2]	15.50	11.20	1175 [554]	73	
			2	30,400 [8.9]	14,600 [4.3]				1675 [790]	74	
RGGD-10?ZCM?			1	18,400 [5.4]	7,000 [2.1]	44,500 [13.0]	15.50	11.25	1175 [554]	73	
			2	30,050 [8.8]	14,550 [4.3]				1625 [767]	74	
RGGD-12?RCM?			1	18,500 [5.4]	7,100 [2.1]	45,000 [13.2]	16.00	11.60	1225 [578]	73	
			2	30,500 [8.9]	14,700 [4.3]				1650 [779]	74	
RGJD-09?ZCM?			1	18,350 [5.4]	7,050 [2.1]	45,000 [13.2]	15.50	11.25	1175 [554]	73	
			2	30,350 [8.9]	14,650 [4.3]				1675 [790]	74	
RGJD-10?ZCM?			1	18,350 [5.4]	7,050 [2.1]	44,500 [13.0]	15.50	11.30	1175 [554]	73	
			2	30,050 [8.8]	14,550 [4.3]				1625 [767]	74	
RGJD-12?RCM?			1	18,500 [5.4]	7,100 [2.1]	45,000 [13.2]	16.00	11.60	1225 [578]	73	
			2	30,500 [8.9]	14,700 [4.3]				1650 [779]	74	
RGLR-07?BRQ?			1	18,500 [5.4]	7,100 [2.1]	45,000 [13.2]	16.00	11.80	1225 [578]	73	
			2	30,500 [8.9]	14,700 [4.3]				1625 [767]	74	
RGLR-10?BRM?			1	18,500 [5.4]	7,100 [2.1]	45,000 [13.2]	16.00	11.90	1200 [566]	73	
			2	30,450 [8.9]	14,750 [4.3]				1575 [743]	74	
RGLR-12?ARM?			1	18,500 [5.4]	7,100 [2.1]	45,000 [13.2]	16.00	11.95	1200 [566]	73	
			2	30,450 [8.9]	14,750 [4.3]				1600 [755]	74	
RGPR-07?BRQ?			1	18,700 [5.5]	7,100 [2.1]	45,000 [13.2]	16.00	11.90	1225 [578]	73	
			2	30,500 [8.9]	14,700 [4.3]				1625 [767]	74	
RGPR-10?BRM?			1	18,550 [5.4]	7,050 [2.1]	45,000 [13.2]	16.00	11.60	1200 [566]	73	
			2	30,350 [8.9]	14,650 [4.3]				1625 [767]	74	
RGPR-12?ARM?	1	18,650 [5.5]	7,150 [2.1]	45,500 [13.3]	16.00	12.00	1250 [590]	73			
	2	30,650 [9.0]	14,750 [4.3]				1575 [743]	74			
RCFN-H*4824A*	Coil Only	1	21,450 [6.3]	4,950 [1.5]	47,500 [13.9]	15.00	12.05	1200 [566]	73		
		2	35,100 [10.3]	12,500 [3.7]				1600 [755]	74		
	RGFD-09?ZCM?	1	21,100 [6.2]	5,900 [1.7]	47,500 [13.9]	17.00	12.00	1150 [543]	73		
		2	35,150 [10.3]	12,450 [3.6]				1600 [755]	74		
	RGFD-10?ZCM?	1	21,100 [6.2]	5,900 [1.7]	47,000 [13.8]	16.50	11.65	1175 [554]	73		
		2	34,800 [10.2]	12,400 [3.6]				1625 [767]	74		
	RGFD-12?RCM?	1	21,200 [6.2]	6,000 [1.8]	48,000 [14.1]	17.00	12.30	1225 [578]	73		
		2	35,400 [10.4]	12,600 [3.7]				1650 [779]	74		
	RGGD-09?ZCM?	1	21,050 [6.2]	5,950 [1.7]	47,500 [13.9]	16.50	11.80	1175 [554]	73		
		2	35,100 [10.3]	12,500 [3.7]				1675 [790]	74		

① Highest sales volume tested combination required by DOE test procedures.

[ ] Designates Metric Conversions

# Performance Data @ ARI Standard Conditions—Cooling

Outdoor Unit RASL-	Model Numbers		Stage	ARI Cooling Performance 80°F [26.5°C] DB / 67°F [19.5°C] WB Indoor Air 95°F [35°C] DB Outdoor Air											
				Net Sensible BTU/H [kW]	Net Latent BTU/H [kW]	ARI Ratings			Indoor Airflow CFM [L/s]	Sound Rating db					
	ID Coil	ID Air Mover				Total Capacity BTU/H [kW]	SEER	EER							
REV. 10/8/2008	RCFN-H*4824A*		1	21,050 [6.2]	5,950 [1.7]	47,500 [13.9]	16.50	11.85	1175 [554]	73					
				34,950 [10.2]	12,450 [3.6]				1625 [767]	74					
			2	1	21,400 [6.3]	6,000 [1.8]	48,000 [14.1]	17.00	12.15	1225 [578]	73				
					35,250 [10.3]	12,550 [3.7]				1650 [779]	74				
			1	2	1	21,050 [6.2]	5,950 [1.7]	47,500 [13.9]	16.50	11.80	1175 [554]	73			
						35,100 [10.3]	12,500 [3.7]				1675 [790]	74			
			2	1	2	21,050 [6.2]	5,950 [1.7]	47,500 [13.9]	16.50	11.85	1175 [554]	73			
						34,950 [10.2]	12,450 [3.6]				1625 [767]	74			
			1	2	1	21,400 [6.3]	6,000 [1.8]	48,000 [14.1]	17.00	12.15	1225 [578]	73			
						35,250 [10.3]	12,550 [3.7]				1650 [779]	74			
			2	1	2	21,400 [6.3]	6,000 [1.8]	48,000 [14.1]	17.00	12.40	1225 [578]	73			
						35,250 [10.3]	12,550 [3.7]				1625 [767]	74			
			1	2	1	20,900 [6.1]	5,900 [1.7]	47,000 [13.8]	18.00	12.80	1050 [495]	73			
						34,850 [10.2]	12,350 [3.6]				1375 [649]	74			
			2	1	2	20,900 [6.1]	5,900 [1.7]	47,500 [13.9]	18.00	12.80	1050 [495]	73			
						34,950 [10.2]	12,450 [3.6]				1425 [672]	74			
			1	2	1	20,900 [6.1]	5,900 [1.7]	47,000 [13.8]	18.00	12.75	1050 [495]	73			
						34,800 [10.2]	12,400 [3.6]				1400 [661]	74			
			2	1	2	21,200 [6.2]	6,000 [1.8]	47,500 [13.9]	17.00	12.15	1200 [566]	73			
						35,100 [10.3]	12,500 [3.7]				1625 [767]	74			
			1	2	1	21,350 [6.3]	6,050 [1.8]	48,000 [14.1]	17.50	12.55	1250 [590]	73			
						35,400 [10.4]	12,600 [3.7]				1575 [743]	74			
			048JEC	RCQD-4821A*		1	19,300 [5.7]	5,500 [1.6]	46,000 [13.5]	15.00	11.90	1175 [554]	73		
							33,650 [9.9]	12,350 [3.6]				1550 [731]	74		
						2	1	1	19,750 [5.8]	5,650 [1.7]	46,000 [13.5]	16.50	11.75	1150 [543]	73
									33,500 [9.8]	12,300 [3.6]				1600 [755]	74
						1	2	1	19,800 [5.8]	5,600 [1.6]	45,500 [13.3]	16.00	11.40	1175 [554]	73
									33,350 [9.8]	12,250 [3.6]				1625 [767]	74
2	1	2				19,750 [5.8]	5,650 [1.7]	46,000 [13.5]	16.00	11.50	1175 [554]	73			
						33,650 [9.9]	12,350 [3.6]				1675 [790]	74			
1	2	1				19,750 [5.8]	5,650 [1.7]	46,000 [13.5]	16.00	11.60	1175 [554]	73			
						33,500 [9.8]	12,300 [3.6]				1625 [767]	74			
2	1	2				20,100 [5.9]	5,700 [1.7]	46,000 [13.5]	17.00	12.15	1225 [578]	73			
						33,800 [9.9]	12,400 [3.6]				1625 [767]	74			
1	2	1				19,750 [5.8]	5,650 [1.7]	46,000 [13.5]	16.50	11.90	1200 [566]	73			
						33,650 [9.9]	12,350 [3.6]				1625 [767]	74			
RCQD-4824A*	RCQD-4824A*					1	19,300 [5.7]	5,500 [1.6]	46,000 [13.5]	15.00	11.90	1000 [472]	73		
							34,050 [10.0]	12,150 [3.6]				1600 [755]	74		
						2	1	2	20,500 [6.0]	5,900 [1.7]	47,000 [13.8]	17.50	13.15	1200 [566]	73
									34,800 [10.2]	12,400 [3.6]				1600 [755]	74
						1	2	1	20,250 [5.9]	5,750 [1.7]	46,000 [13.5]	16.00	11.85	1150 [543]	73
									34,050 [10.0]	12,150 [3.6]				1600 [755]	74
						2	1	2	20,250 [5.9]	5,750 [1.7]	46,000 [13.5]	16.00	11.55	1175 [554]	73
									33,750 [9.9]	12,050 [3.5]				1625 [767]	74
						1	2	1	20,400 [6.0]	5,800 [1.7]	46,500 [13.6]	16.00	12.15	1225 [578]	73
									34,350 [10.1]	12,250 [3.6]				1650 [779]	74
						2	1	2	20,200 [5.9]	5,800 [1.7]	46,500 [13.6]	16.00	11.65	1175 [554]	73
									34,200 [10.0]	12,200 [3.6]				1675 [790]	74
						1	2	1	20,200 [5.9]	5,800 [1.7]	46,000 [13.5]	16.00	11.75	1175 [554]	73
									33,900 [9.9]	12,100 [3.5]				1625 [767]	74
			2	1	2	20,550 [6.0]	5,850 [1.7]	46,500 [13.6]	16.50	12.05	1225 [578]	73			
						34,350 [10.1]	12,250 [3.6]				1650 [779]	74			
			1	2	1	20,550 [6.0]	5,850 [1.7]	46,500 [13.6]	16.50	12.30	1225 [578]	73			
						34,350 [10.1]	12,250 [3.6]				1625 [767]	74			

① Highest sales volume tested combination required by DOE test procedures.

[ ] Designates Metric Conversions



# Performance Data @ ARI Standard Conditions—Cooling

Outdoor Unit RASL-	Model Numbers		Stage	ARI Cooling Performance 80°F [26.5°C] DB / 67°F [19.5°C] WB Indoor Air 95°F [35°C] DB Outdoor Air							
				Net Sensible BTU/H [kW]	Net Latent BTU/H [kW]	ARI Ratings			Indoor Airflow CFM [L/s]	Sound Rating db	
	Total Capacity BTU/H [kW]	SEER				EER					
REV. 10/8/2008  048JEC	RCQD-4824A*	RGPR-10?BRM?	1	20,400 [6.0]	5,800 [1.7]	46,500 [13.6]	16.50	12.05	1200 [566]	73	
			2	34,200 [10.0]	12,200 [3.6]				1625 [767]	74	
		RGPR-12?ARM?	1	20,550 [6.0]	5,850 [1.7]	46,500 [13.6]	16.50	12.40	1250 [590]	73	
			2	34,350 [10.1]	12,250 [3.6]				1575 [743]	74	
	RCSM-H*4824A*	RHPL-HM4824	1	18,800 [5.5]	7,200 [2.1]	46,000 [13.5]	17.00	12.60	1250 [590]	73	
			2	30,900 [9.1]	14,900 [4.4]				1625 [767]	74	
060JEC	RCSN-H*6024A* ①	RHPN-HM6024	1	23,550 [6.9]	8,850 [2.6]	57,000 [16.7]	18.00	12.30	1050 [495]	67	
			2	39,200 [11.5]	18,000 [5.3]				1700 [802]	72	
			1 - dehumid	22,500 [6.6]	10,300 [3.0]				925 [437]	67	
			2 - dehumid	37,400 [11.0]	20,800 [6.1]				1325 [625]	72	
	RCFM-H*6024A*	Coil Only	1	20,950 [6.1]	9,450 [2.8]	56,500 [16.6]	14.50	11.35	1050 [495]	67	
			2	38,600 [11.3]	17,800 [5.2]				1700 [802]	72	
		RGFD-09?ZCM?	1	23,550 [6.9]	8,850 [2.6]	56,000 [16.4]	16.00	11.30	1150 [543]	67	
			2	38,400 [11.3]	17,600 [5.2]				1600 [755]	72	
		RGFD-10?ZCM?	1	23,550 [6.9]	8,850 [2.6]	56,000 [16.4]	15.50	11.05	1175 [554]	67	
			2	38,250 [11.2]	17,550 [5.1]				1625 [767]	72	
		RGFD-12?RCM?	1	21,950 [6.4]	8,250 [2.4]	56,500 [16.6]	15.00	11.55	725 [342]	67	
			2	38,650 [11.3]	17,750 [5.2]				1650 [779]	72	
		RGGD-09?ZCM?	1	23,700 [6.9]	8,900 [2.6]	56,500 [16.6]	15.50	11.20	1175 [554]	67	
			2	38,700 [11.3]	17,700 [5.2]				1675 [790]	72	
		RGGD-10?ZCM?	1	23,700 [6.9]	8,900 [2.6]	56,000 [16.4]	15.50	11.20	1175 [554]	67	
			2	38,400 [11.3]	17,600 [5.2]				1625 [767]	72	
		RGGD-12?RCM?	1	24,000 [7.0]	9,000 [2.6]	56,500 [16.6]	16.00	11.45	1225 [578]	67	
			2	38,650 [11.3]	17,750 [5.2]				1650 [779]	72	
		RGJD-09?ZCM?	1	23,700 [6.9]	8,900 [2.6]	56,500 [16.6]	15.50	11.20	1175 [554]	67	
			2	38,700 [11.3]	17,700 [5.2]				1675 [790]	72	
		RGJD-10?ZCM?	1	23,700 [6.9]	8,900 [2.6]	56,000 [16.4]	15.50	11.20	1175 [554]	67	
			2	38,400 [11.3]	17,600 [5.2]				1625 [767]	72	
		RGJD-12?RCM?	1	24,000 [7.0]	9,000 [2.6]	56,500 [16.6]	16.00	11.45	1225 [578]	67	
			2	38,650 [11.3]	17,750 [5.2]				1650 [779]	72	
		RGLR-07?BRQ?	1	24,000 [7.0]	9,000 [2.6]	56,500 [16.6]	16.00	11.60	1225 [578]	67	
			2	38,650 [11.3]	17,750 [5.2]				1625 [767]	72	
		RGLR-10?BRM?	1	23,850 [7.0]	8,950 [2.6]	56,000 [16.4]	16.50	11.65	1200 [566]	67	
			2	38,500 [11.3]	17,700 [5.2]				1575 [743]	72	
		RGLR-12?ARM?	1	23,800 [7.0]	9,000 [2.6]	56,500 [16.6]	16.50	11.70	1200 [566]	67	
			2	38,650 [11.3]	17,750 [5.2]				1600 [755]	72	
		RGPR-07?BRQ?	1	24,000 [7.0]	9,000 [2.6]	56,500 [16.6]	16.50	11.65	1225 [578]	67	
			2	38,650 [11.3]	17,750 [5.2]				1625 [767]	72	
		RGPR-10?BRM?	1	23,850 [7.0]	8,950 [2.6]	56,000 [16.4]	16.00	11.45	1200 [566]	67	
			2	38,500 [11.3]	17,700 [5.2]				1625 [767]	72	
		RGPR-12?ARM?	1	23,950 [7.0]	9,050 [2.7]	56,000 [16.4]	16.50	11.70	1250 [590]	67	
			2	38,500 [11.3]	17,700 [5.2]				1575 [743]	72	
		RCFN-H*6024A*	Coil Only	1	24,750 [7.3]	7,650 [2.2]	56,500 [16.6]	15.00	11.65	1275 [602]	67
				2	38,600 [11.3]	17,800 [5.2]				1700 [802]	72
			RGFD-09?ZCM?	1	23,550 [6.9]	8,850 [2.6]	56,000 [16.4]	16.50	11.60	1150 [543]	67
				2	38,400 [11.3]	17,600 [5.2]				1600 [755]	72
	RGFD-10?ZCM?		1	23,550 [6.9]	8,850 [2.6]	56,000 [16.4]	16.00	11.35	1175 [554]	67	
			2	38,250 [11.2]	17,550 [5.1]				1625 [767]	72	
	RGFD-12?RCM?		1	23,850 [7.0]	8,950 [2.6]	56,500 [16.6]	16.50	11.85	1225 [578]	67	
			2	38,650 [11.3]	17,750 [5.2]				1650 [779]	72	
	RGGD-09?ZCM?		1	23,700 [6.9]	8,900 [2.6]	56,500 [16.6]	16.00	11.50	1175 [554]	67	
			2	38,700 [11.3]	17,700 [5.2]				1675 [790]	72	
	RGGD-10?ZCM?		1	23,700 [6.9]	8,900 [2.6]	56,000 [16.4]	16.00	11.50	1175 [554]	67	
			2	38,400 [11.3]	17,600 [5.2]				1625 [767]	72	

① Highest sales volume tested combination required by DOE test procedures.

[ ] Designates Metric Conversions



# Performance Data @ ARI Standard Conditions—Cooling

Outdoor Unit RASL-	Model Numbers		Stage	ARI Cooling Performance 80°F [26.5°C] DB / 67°F [19.5°C] WB Indoor Air 95°F [35°C] DB Outdoor Air							
				Net Sensible BTU/H [kW]	Net Latent BTU/H [kW]	ARI Ratings			Indoor Airflow CFM [L/s]	Sound Rating db	
	ID Coil	ID Air Mover				Total Capacity BTU/H [kW]	SEER	EER			
REV. 10/8/2008	RCFN-H*6024A*		1	24,000 [7.0]	9,000 [2.6]	56,500 [16.6]	16.50	11.75	1225 [578]	67	
				38,650 [11.3]	17,750 [5.2]				1650 [779]	72	
			1	2	23,700 [6.9]	8,900 [2.6]	56,500 [16.6]	16.00	11.50	1175 [554]	67
					38,700 [11.3]	17,700 [5.2]				1675 [790]	72
			1	2	23,700 [6.9]	8,900 [2.6]	56,000 [16.4]	16.00	11.50	1175 [554]	67
					38,400 [11.3]	17,600 [5.2]				1625 [767]	72
			1	2	24,000 [7.0]	9,000 [2.6]	56,500 [16.6]	16.50	11.75	1225 [578]	67
					38,650 [11.3]	17,750 [5.2]				1650 [779]	72
			1	2	24,000 [7.0]	9,000 [2.6]	56,500 [16.6]	16.50	11.90	1225 [578]	67
					38,650 [11.3]	17,750 [5.2]				1625 [767]	72
			1	2	23,850 [7.0]	8,950 [2.6]	56,000 [16.4]	17.00	11.95	1200 [566]	67
					38,500 [11.3]	17,700 [5.2]				1575 [743]	72
			1	2	23,800 [7.0]	9,000 [2.6]	56,500 [16.6]	17.00	12.00	1200 [566]	67
					38,650 [11.3]	17,750 [5.2]				1600 [755]	72
			1	2	24,000 [7.0]	9,000 [2.6]	56,500 [16.6]	17.00	11.95	1225 [578]	67
					38,650 [11.3]	17,750 [5.2]				1625 [767]	72
			1	2	23,850 [7.0]	8,950 [2.6]	56,000 [16.4]	16.50	11.75	1200 [566]	67
					38,500 [11.3]	17,700 [5.2]				1625 [767]	72
			1	2	23,950 [7.0]	9,050 [2.7]	56,000 [16.4]	17.00	12.00	1250 [590]	67
					38,500 [11.3]	17,700 [5.2]				1575 [743]	72
060JEC	RCQD-6024A*		1	21,050 [6.2]	8,750 [2.6]	53,500 [15.7]	14.00	11.10	1050 [495]	67	
				36,100 [10.6]	17,300 [5.1]				1700 [802]	72	
			1	2	22,500 [6.6]	9,300 [2.7]	54,500 [16.0]	16.50	12.00	1275 [602]	67
					36,800 [10.8]	17,600 [5.2]				1700 [802]	72
			1	2	21,750 [6.4]	9,050 [2.7]	53,000 [15.5]	15.50	11.10	1150 [543]	67
					35,850 [10.5]	17,150 [5.0]				1600 [755]	72
			1	2	21,750 [6.4]	9,050 [2.7]	53,000 [15.5]	15.00	10.85	1175 [554]	67
					35,700 [10.5]	17,100 [5.0]				1625 [767]	72
			1	2	22,050 [6.5]	9,150 [2.7]	53,500 [15.7]	15.50	11.35	1225 [578]	67
					36,100 [10.6]	17,300 [5.1]				1650 [779]	72
			1	2	21,900 [6.4]	9,100 [2.7]	53,000 [15.5]	15.50	11.00	1175 [554]	67
					35,950 [10.5]	17,250 [5.1]				1675 [790]	72
			1	2	21,900 [6.4]	9,100 [2.7]	53,000 [15.5]	15.50	11.00	1175 [554]	67
					35,850 [10.5]	17,150 [5.0]				1625 [767]	72
			1	2	22,050 [6.5]	9,150 [2.7]	53,500 [15.7]	15.50	11.25	1225 [578]	67
					36,150 [10.6]	17,250 [5.1]				1650 [779]	72
			1	2	22,000 [6.4]	9,200 [2.7]	53,500 [15.7]	16.00	11.45	1225 [578]	67
					36,100 [10.6]	17,300 [5.1]				1625 [767]	72
			1	2	21,900 [6.4]	9,100 [2.7]	53,000 [15.5]	15.50	11.25	1200 [566]	67
					35,950 [10.5]	17,250 [5.1]				1625 [767]	72
1	2	22,200 [6.5]	9,200 [2.7]	53,000 [15.5]	16.00	11.50	1250 [590]	67			
		35,950 [10.5]	17,250 [5.1]				1575 [743]	72			
1	2	24,750 [7.3]	9,250 [2.7]	57,500 [16.8]	17.00	12.45	1400 [661]	67			
		39,350 [11.5]	18,050 [5.3]				1700 [802]	72			

① Highest sales volume tested combination required by DOE test procedures.

[ ] Designates Metric Conversions

# Electrical and Physical Data

Model Number RASL-	ELECTRICAL						PHYSICAL						
	Phase Frequency (Hz) Voltage (Volts)	Compressor		Fan Motor Full Load Amperes (FLA)	Min. Circuit Ampacity Amperes	Fuse or HACR Circuit Breaker		Outdoor Coil			Refrig. Per Circuit Oz. [g]	Weight	
		Rated Load Amperes (RLA)	Locked Rotor Amperes (LRA)			Min. Amperes	Max. Amperes	Face Area Sq. Ft. [m <sup>2</sup> ]	No. Rows	CFM [L/s]		Net Lbs. [kg]	Shipping Lbs. [kg]
REV. 10/8/2008													
024JEC	1-60-208/230	10.3/10.3	52	0.5	14/14	20/20	20/20	15.8 [1.47]	1	2200/2500 [1038/1180]	144 [4082]	236 [107.0]	256 [116.1]
036JEC	1-60-208/230	16.7/16.7	82	2.8	24/24	30/30	40/40	23.01 [2.14]	1	2800/3400 [1321/1604]	150 [4252]	251 [113.6]	261 [118.2]
039JEC	1-60-208/230	17.9/17.9	96	2.8	26/26	30/30	40/40	23.00 [2.14]	2	2800/3500 [1321/1652]	268 [7598]	326 [147.9]	336 [152.4]
048JEC	1-60-208/230	26.9/26.9	117	2.8	37/37	45/45	60/60	23.00 [2.14]	2	2800/3500 [1321/1652]	253 [7173]	326 [148.0]	336 [152.4]
060JEC	1-60-208/230	28.2/28.2	146	2.8	39/39	50/50	60/60	23.00 [2.14]	2	2800/3500 [1321/1652]	241 [6832]	328 [149.0]	338 [153.3]

## Unit Dimensions

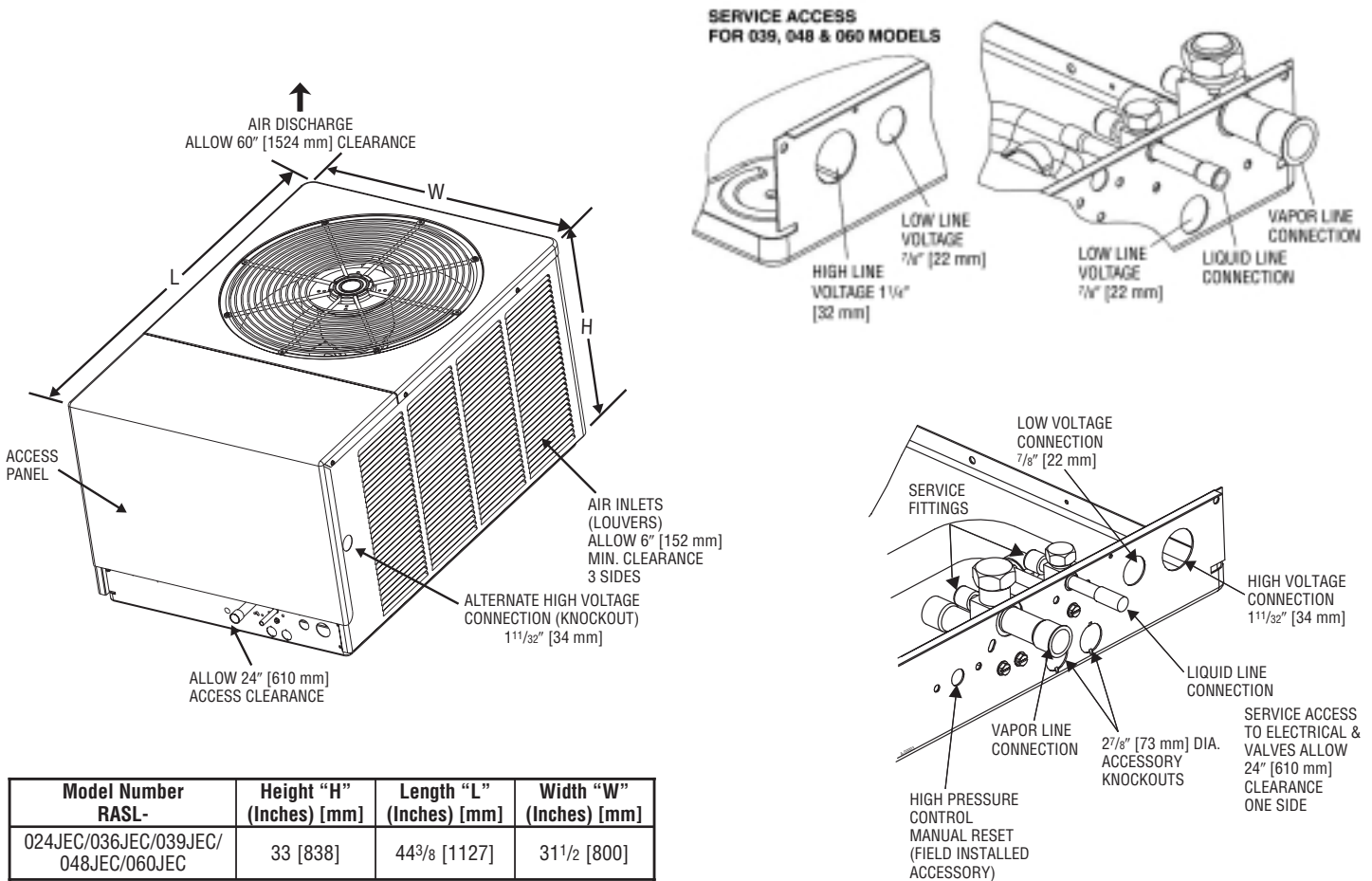

[ ] Designates Metric Conversions

# Condensing Unit Refrigerant Line Size Information

Liquid Line Sizing (2-Stage R-410A)								
R-410A System Capacity Model	Line Size Connection Size (Inch I.D.) [mm]	Line Size (Inch O.D.) [mm]	Liquid Line Size Outdoor Unit Above Indoor Coil (Cooling Only - Does not apply to Heat Pumps)					
			Total Equivalent Length—Feet [m]					
			25 [7.62]	50 [15.24]	75 [22.86]	100 [30.48]	125 [38.10]	150 [45.72]
			Minimum Vertical Separation—Feet [m]					
-024	3/8" [9.53]	1/4" [6.35]*	0	0	10 [3.05]	34 [10.36]	58 [17.68]	82 [24.99]
		5/16" [7.93]	0	0	0	0	0	0
		3/8" [9.52]	0	0	0	0	0	0
-036	3/8" [9.53]	5/16" [7.93]	0	0	6 [1.83]	14 [4.27]	21 [6.40]	28 [8.53]
		3/8" [9.52]*	0	0	0	0	0	0
		1/2" [12.70]	0	0	0	0	0	0
-039	3/8" [9.53]	5/16" [7.93]*	0	0	0	0	10 [3.05]	24 [7.32]
		3/8" [9.52]	0	0	0	0	0	0
		1/2" [12.70]	0	0	0	0	0	0
-048	3/8" [9.53]	5/16" [7.93]*	0	0	0	18 [5.49]	40 [12.19]	62 [18.90]
		3/8" [9.52]	0	0	0	0	0	0
		1/2" [12.70]	0	0	0	0	0	0
-060	3/8" [9.53]	3/8" [9.52]*	0	0	0	0	0	0
		1/2" [12.70]	0	0	0	0	0	0

Liquid Line Sizing (2-Stage R-410A)								
R-410A System Capacity Model	Line Size Connection Size (Inch I.D.) [mm]	Line Size (Inch O.D.) [mm]	Liquid Line Size Outdoor Unit Below Indoor Coil (Cooling Only - Does not apply to Heat Pumps)					
			Total Equivalent Length—Feet [m]					
			25 [7.62]	50 [15.24]	75 [22.86]	100 [30.48]	125 [38.10]	150 [45.72]
			Maximum Vertical Separation—Feet [m]					
-024	3/8" [9.53]	1/4" [6.35]*	25 [11.28]	13 [3.96]	N/A	N/A	N/A	N/A
		5/16" [7.93]	25 [14.33]	44 [13.41]	40 [12.19]	36 [10.97]	30 [9.14]	24 [7.32]
		3/8" [9.52]	25 [15.24]	48 [14.63]	47 [14.33]	46 [14.02]	45 [13.72]	43 [13.11]
-036	3/8" [9.53]	5/16" [7.93]	N/A	N/A	N/A	N/A	N/A	N/A
		3/8" [9.52]*	12 [3.66]	9 [2.74]	N/A	N/A	N/A	N/A
		1/2" [12.70]	14 [4.27]	13 [3.96]	13 [3.96]	12 [3.66]	12 [3.66]	11 [3.35]
-039	3/8" [9.53]	5/16" [7.93]*	15 [4.57]	11 [3.35]	N/A	N/A	N/A	N/A
		3/8" [9.52]	18 [5.49]	17 [5.18]	15 [4.57]	13 [3.96]	12 [3.66]	10 [3.05]
		1/2" [12.70]	20 [6.10]	19 [5.79]	19 [5.79]	19 [5.79]	18 [5.49]	18 [5.49]
-048	3/8" [9.53]	5/16" [7.93]*	25 [10.36]	24 [7.32]	N/A	N/A	N/A	N/A
		3/8" [9.52]	25 [11.89]	36 [10.97]	34 [10.36]	32 [9.75]	29 [8.84]	23 [7.01]
		1/2" [12.70]	25 [12.50]	40 [12.19]	40 [12.19]	39 [11.89]	39 [11.89]	38 [11.58]
-060	3/8" [9.53]	3/8" [9.52]*	25 [11.28]	33 [10.06]	30 [9.14]	25 [7.62]	15 [4.57]	N/A
		1/2" [12.70]	25 [11.89]	39 [11.89]	38 [11.58]	37 [11.28]	37 [11.28]	36 [10.97]

NOTES: N/A = Application not recommended.  
 \*Standard line size.

[ ] Designates Metric Conversions

## Condensing Unit Refrigerant Line Size Information (Con't.)

SUCTION LINE SIZE - OUTDOOR UNIT ABOVE INDOOR COIL							
R-410A System Capacity Model	Line Size Connection Size (Inch I.D.) [mm]	Line Size (Inch O.D.) [mm]	Suction Line Size				
			Outdoor Unit ABOVE Indoor Coil (Cooling Only - Does not apply to Heat Pumps)				
			Total Equivalent Length - Feet [m]				
			25 [7.62]	50 [15.24]	75 [22.86]	100 [30.48]	125 [45.72]
-024	3/4" [19.05]	5/8" [15.88]	Same as Liquid Line Size Table				
		3/4" [19.05]*	N/A				
		7/8" [22.23]	N/A				
-036 & -039	3/4" [19.05]	5/8" [15.88]	Same as Liquid Line Size Table				
		3/4" [19.05]*	N/A				
		7/8" [22.23]	N/A				
-048	7/8" [22.23]	5/8" [15.88]	Same as Liquid Line Size Table				
		3/4" [19.05]	Same as Liquid Line Size Table				
		7/8" [22.23]*	N/A				
-060	7/8" [22.23]	3/4" [19.05]	Same as Liquid Line Size Table				
		7/8" [22.23]*	N/A				
		1-1/8" [28.58]	N/A				

SUCTION LINE SIZE - OUTDOOR UNIT BELOW INDOOR COIL							
R-410A System Capacity Model	Line Size Connection Size (Inch I.D.) [mm]	Line Size (Inch O.D.) [mm]	Suction Line Size				
			Outdoor Unit BELOW Indoor Coil (Cooling Only - Does not apply to Heat Pumps)				
			Total Equivalent Length - Feet [m]				
			25 [7.62]	50 [15.24]	75 [22.86]	100 [30.48]	125 [45.72]
-024	3/4" [19.05]	5/8" [15.88]	Same as Liquid Line Size Table				
		3/4" [19.05]*	Same as Liquid Line Size Table		N/A		
		7/8" [22.23]	N/A				
-036 & -039	3/4" [19.05]	5/8" [15.88]	Same as Liquid Line Size Table				
		3/4" [19.05]*	Same as Liquid Line Size Table				
		7/8" [22.23]	N/A				
-048	7/8" [22.23]	5/8" [15.88]	Same as Liquid Line Size Table				
		3/4" [19.05]	Same as Liquid Line Size Table				
		7/8" [22.23]*	Same as Liquid Line Size Table		N/A		
-060	7/8" [22.23]	3/4" [19.05]	Same as Liquid Line Size Table				
		7/8" [22.23]*	Same as Liquid Line Size Table				
		1-1/8" [28.58]	N/A				

NOTES: Using suction line larger than shown in chart will result in poor oil return. N/A = Application not recommended.

\*Standard line size.

[ \* ] Designates Metric Conversions

# Vapor Line Capacity Multiplier

RASL		024	036	039	048	060
Unit Vapor Line Connection Size (Inches I.D.) [mm]		3/4" [19.05] I.D. Sweat	3/4" [19.05] I.D. Sweat	7/8" [22.23] I.D. Sweat	7/8" [22.23] I.D. Sweat	7/8" [22.23] I.D. Sweat
Vapor Line Run Feet [m]		Vapor Line Diameter (inches O.D.) [mm]				
		5/8" [15.88] Optional	5/8" [15.88] Optional	5/8" [15.88] Optional	5/8" [15.88] Optional	3/4" [19.05] Optional
		3/4" [19.05] Standard	3/4" [19.05] Standard	3/4" [19.05] Standard	3/4" [19.05] Standard	7/8" [22.23] Standard
25' [7.62]	Optional	1.00	0.99	0.99	0.98	0.99
	Standard	1.00	1.00	1.00	1.00	1.00
50' [15.24]	Optional	0.98	0.98	0.97	0.96	0.98
	Standard	1.00	1.00	0.99	0.99	0.99
75' [22.86]	Optional	0.98	0.96	0.96	0.94	0.96
	Standard	1.00	0.99	0.99	0.98	0.96
100' [22.86]	Optional	0.98	0.95	0.95	0.92	0.95
	Standard	N/A	N/A	N/A	N/A	N/A
125' [38.10]	Optional	0.96	0.94	0.93	0.90	0.94
	Standard	N/A	N/A	N/A	N/A	N/A
150' [45.72]	Optional	0.96	0.92	0.91	0.88	0.93
	Standard	N/A	N/A	N/A	N/A	N/A

**NOTES:**

1. Do NOT exceed the limits in the liquid and suction line sizing charts.
2. Do NOT use 7/8 OD suction lines in 2, 3, or 4-ton applications.
3. Do NOT use 1-1/8 OD suction line in ANY application.
4. Line sets over 75 feet MUST use the optional suction line.

[ ] Designates Metric Conversions

## GENERAL TERMS OF LIMITED WARRANTY

Rheem will furnish a replacement for any part of this product which fails in normal use and service within the applicable period stated, in accordance with the terms of the limited warranty.

**For Complete Details of the Limited Warranty, Including Applicable Terms and Conditions, See Your Local Installer or Contact the Manufacturer for a Copy.**

Limited Parts Warranty:

Rheem *Prestige Series*<sup>TM</sup> equipment features a 10-year limited parts warranty.\*

\*This ten-year limited parts warranty is applicable only to single-phase products installed in residential applications.

### **RASL- JEC Conditional Replacement Warranty:**

Rheem will provide a replacement model (if an exact replacement is not available, an equivalent product will be provided) to the original purchaser if the compressor fails within 10 years (providing the unit is installed with a new Rheem Air Handler OR Rheem Indoor Coil with a Rheem Gas Furnace, and is properly matched as specified by Rheem and/or listed in the Air Conditioning Institute (ARI) published rating, and if additional conditions are satisfied. See product warranty card for additional information.

**BEFORE PURCHASING THIS APPLIANCE, READ IMPORTANT ENERGY COST AND EFFICIENCY INFORMATION AVAILABLE FROM YOUR RETAILER.**

Before proceeding with installation, refer to installation instructions packaged with each model, as well as complying with all Federal, State, Provincial, and Local codes, regulations, and practices.

**Rheem Heating,  
Cooling and  
Water Heating**

P.O. Box 17010, Fort Smith, AR 72917



*"In keeping with its policy of continuous progress and product improvement, Rheem reserves the right to make changes without notice."*