

# GAS FURNACES



## **CLASSIC® SERIES SUPER QUIET 80™ 80.0% A.F.U.E.† UPFLOW/HORIZONTAL GAS FURNACES w/ECM MOTOR**

The Rheem *Classic® Series Super Quiet 80™* line of upflow/horizontal gas furnaces are designed for utility rooms, closets, alcoves, or attics. **Because of the Super Quiet 80's low-profile 34 inch [864 mm] height, the upflow model can also be used to satisfy most applications that traditionally call for a horizontal furnace.**

The design is certified by CSA International.

### Features

- Innovative combustion design results in reliable, efficient operation at sound levels which provide distinct competitive advantage.
- Patented Heat Exchanger, constructed of both stainless and aluminized steel for the maximum in corrosion resistance.
- Low profile "34 inch" design is lighter and easier to handle, and leaves room for optional equipment.
- Convertible from upflow to horizontal left or right without field conversion.
- Left or right side gas and electric inlet connections with quick, simple change.
- Robust and reliable direct spark ignition utilizing remote sense and an integrated board with humidifier and electronic air cleaner hookups.
- Insulated blower compartment helps to reduce jacket loss and noise.
- Pre-paint galvanized steel cabinet.
- Molded permanent filter.
- Grab-holes in doors to aid in easy door removal and replacement.
- ECM X-13 Blower Motor.

A variety of cooling coils and plenums designed to use with Rheem *Classic® Series Super Quiet 80™* gas furnaces are available as optional accessories.

These furnaces can be installed in an upflow position or laid on either side in a horizontal position. Field conversion not required.

†A.F.U.E. (Annual Fuel Utilization Efficiency) calculated in accordance with Department of Energy test procedures.

### RGPT- SERIES

**Models with Input Rates from  
50,000 to 125,000 BTU/HR  
[15 to 37 kW]  
(U.S. & Canadian Models)**

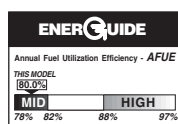



# CLASSIC® SERIES SUPER QUIET 80™ UPFLOW/HORIZONTAL GAS FURNACE

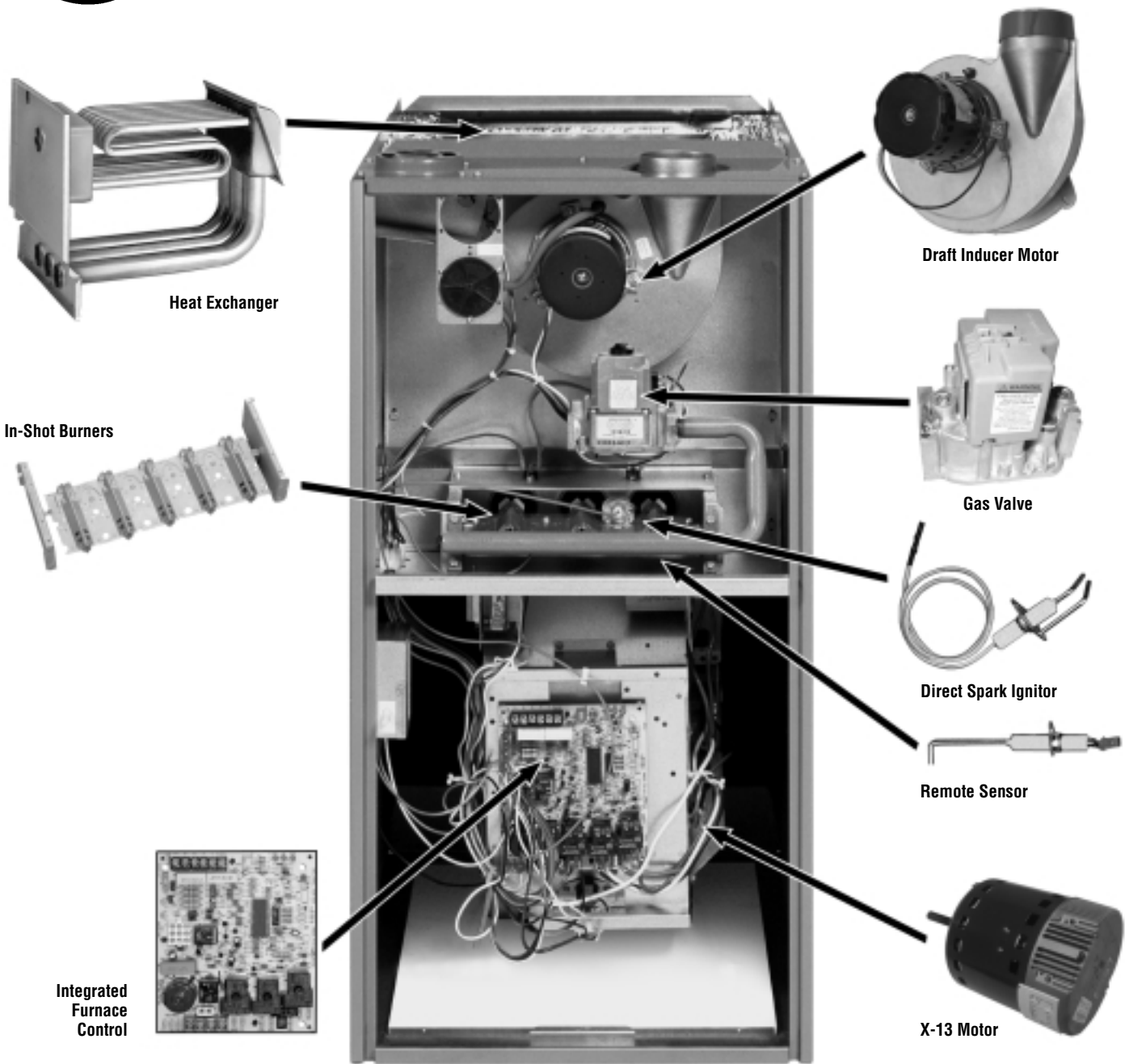

## STANDARD EQUIPMENT

Completely assembled and wired; induced draft blower; pressure switch; redundant main gas control; blower compartment door safety switch; solid state time on/time off blower control; limit control; manual shut-off valve, pressure regulator for natural and L.P. (propane) gas; transformer; direct drive multi-speed blower with Regal Beloit X-13 Motor. Furnaces are equipped with cooling/heating relay and transformer (40VA) ready for air conditioning applications. (Please note: a thermostat is not included as standard equipment.) Flame sensor diagnostics; **on-board twinning options**; fused-protection (secondary), **3rd speed fan option for continuous fan**; **common heat/cool terminal**.

## OPTIONAL EQUIPMENT

Side filter frame assembly. Return air cabinet for all sizes.

NOTE: Furnace is not listed for use with fuels other than natural or L.P. (propane) gas.

The complete terms of limited and other warranties are available at our sales office, or through local installer.

All models can be converted by a qualified Rheem distributor or local service dealer to use L.P. (propane) gas without changing burners. Factory approved kits must be used to convert from natural to L.P. (propane) gas and may be ordered as optional accessories from a Rheem parts distributor.

For L.P. (propane) operation, refer to Conversion Kit Index Form.

**WARNING**  
THIS FURNACE IS NOT APPROVED  
OR RECOMMENDED  
FOR USE IN MOBILE HOMES

# PHYSICAL DATA AND SPECIFICATIONS

## U.S. AND CANADA MODELS (UPFLOW/HORIZONTAL)

MODEL NUMBERS RGPT- SERIES	05EBMKR 05NBMKR	07EAMKR 07NAMKR	07EBRQR 07NBRQR	10EBRMR 10NBRMR	12EARMR 12NARMR
Input in BTU's/Hr [kW] ②	50,000 [15]	75,000 [22]	75,000 [22]	100,000 [29]	125,000 [37]
Heating Capacity in BTU's/Hr [kW] ①	41,000 [12]	60,000 [18]	60,000 [18]	81,000 [24]	99,000 [29]
High Altitude Input in BTU's/Hr [kW]*	45,000 [13]	67,500 [20]	67,500 [20]	90,000 [26]	112,500 [33]
High Altitude Output Capacity in BTU's/Hr [kW]*	36,500 [11]	53,500 [16]	53,500 [16]	72,500 [21]	89,000 [26.1]
Heat Ext. Static Pressure in "wc [kPa]	0.1 [0.025]	0.12 [0.029]	0.12 [0.029]	0.15 [0.037]	0.2 [0.05]
Blower (D x W) in inches [mm]	11 x 7 [279 x 178]	11 x 7 [279 x 178]	11 x 10 [279 x 254]	11 x 10 [279 x 254]	11 x 10 [279 x 254]
Motor H.P.-Speeds - Type [W]	3/4hp, 5spd, X-13 [559]	1/2hp, 5spd, X-13 [373]	1hp, 5spd, X-13 [746]	1hp, 5spd, X-13 [746]	1hp, 5spd, X-13 [746]
Motor Full Load Amps	8.4	6.8	10.9	10.9	10.9
Heating Speed (factory setting)	MED-LOW	MED	MED-LOW	MED-HIGH	MED-HIGH
Cooling Speed (factory setting)	HIGH	HIGH	HIGH	HIGH	HIGH
Cooling in CFM [L/s] @ 0.5"wc [0.12 kPa] E.S.P. (nominal)	1600 [775]	1200 [566]	2000 [944]	2000 [944]	2000 [944]
Rated E.S.P. in "wc [kPa]	0.5 [0.12]	0.5 [0.12]	0.5 [0.12]	0.5 [0.12]	0.5 [0.12]
Temperature Rise Range in °F [°C]	25-55 [13.9-30.6]	35-65 [19.4-36.1]	25-55 [13.9-30.6]	30-60 [17-33]	35-65 [19.4-36.1]
Max Outlet Air in °F [°C]	155 [68.3]	165 [73.8]	165 [73.8]	190 [87.7]	180 [82.2]
Standard Filter Dimensions in inches [mm]	15-3/4 x 25 [400 x 635]	15-3/4 x 25 [400 x 635]	19-1/4 x 25 [489 x 635]	19-1/4 x 25 [489 x 635]	22-3/4 x 25 [578 x 635]
Approx. Shipping Weight in Lbs. [kg]	105 [48]	105 [48]	120 [54]	120 [54]	140 [63]
Return Air Cabinets (Opt.) RXGR-?? Filter Size in inches [mm]	C17B (2) 12 x 16 [305 x 406]	C17B (2) 12 x 16 [305 x 406]	C21B (2) 20 x 16 [508 x 406]	C21B (2) 20 x 16 [508 x 406]	C24B (2) 24 x 16 [610 x 406]
AFUE - Electronic Ignition Modules ①	80.0%	80.0%	80.0%	80.0%	80.0%

NOTES: All models are 115V, 60HZ, Single Phase. Gas connection size for all models is 1/2" [12.7 mm] N.P.T.

① In accordance with D.O.E. test procedures.

② See Conversion Kit Index Form for high altitude derate in U.S. applications. For Canadian applications, reference the furnace installation instructions.

\* Data references Canadian applications only.

## MODEL IDENTIFICATION—UPFLOW MODELS

<u>R</u>	<u>G</u>	<u>P</u>	<u>T</u>	<u>07E</u>			<u>A</u>	<u>M</u>	<u>K</u>	<u>R</u>
Rheem	Gas	Upflow/ Horizontal	Design Series	Heating Input Designation			Variations	Blower Designation	Heating & Cooling Designation	Fuel Type
	Furnace			Electric Ignition	NO <sub>x</sub> Model	Input BTU/HR	A = Std. Cabinet	M = 11 x 7 [279 x 178 mm]	K = 600-1200 CFM [283 x 566 L/s]	R = Natural Gas, U.S. and Canadian Standard Furnace
				05E	05N	50,000 [15 kW]	B = Wide Cabinet	R = 11 x 10 [279 x 254 mm]	Q = 1000-1600 CFM [472 x 755 L/s]	
				07E	07N	75,000 [22 kW]			M = 1200-2000 CFM [566 x 944 L/s]	
				10E	10N	100,000 [29 kW]				
				12E	12N	125,000 [37 kW]				

[ ] Designates Metric Conversions

# UPFLOW DIMENSIONS

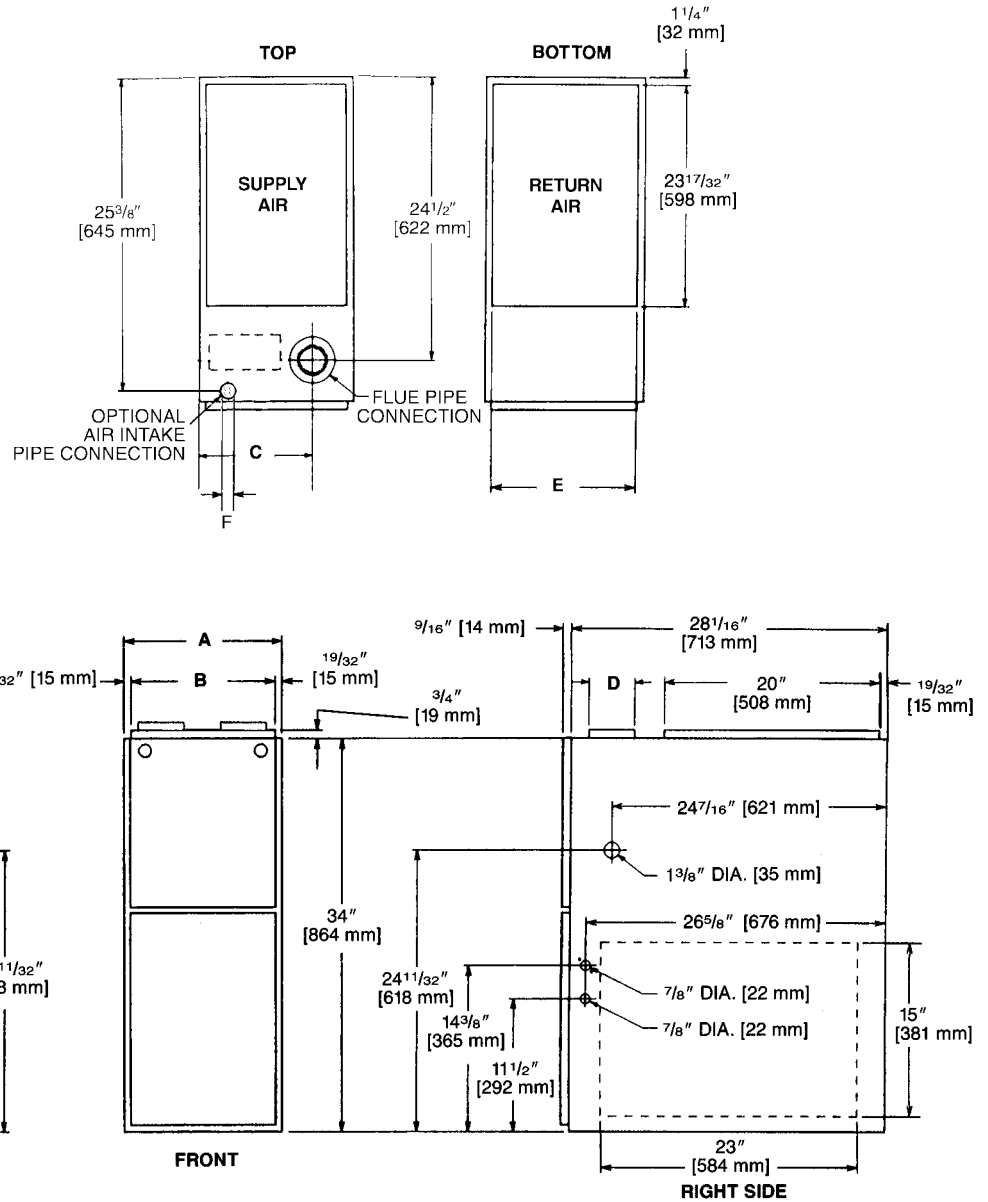

## UPFLOW DIMENSIONS AND CLEARANCE TO COMBUSTIBLE MATERIAL (INCHES) [mm]

MODEL RGPT-	A	B	C	D	E	F	REDUCED CLEARANCES (IN.) [mm]						
							LEFT SIDE	RIGHT SIDE	BACK	TOP	FRONT	VENT	SHIP. WGTS. (LBS.) [kg]
05	17 1/2 [445]	16 11/32 [415]	12 3/8 [314]	Ⓚ	15 [381]	2 1/2 [64]	0	3 [76] ②	0	1 [25]	3 [76]	6 [152] ③	120 [54.4]
07(A)	17 1/2 [445]	16 11/32 [415]	12 3/8 [314]	Ⓚ	15 [381]	2 1/2 [64]	0	3 [76] ②	0	1 [25]	3 [76]	6 [152] ③	120 [54.4]
07(B)	21 [533]	19 27/32 [504]	14 1/8 [359]	Ⓚ	18 1/2 [470]	2 1/2 [64]	0	0	0	1 [25]	3 [76]	6 [152] ③	120 [54.4]
10	21 [533]	19 27/32 [504]	14 1/8 [359]	Ⓚ	18 1/2 [470]	2 1/2 [64]	0	0	0	1 [25]	3 [76]	6 [152] ③	120 [54.4]
12	24 1/2 [622]	23 11/32 [593]	15 7/8 [403]	Ⓚ	22 [559]	2 1/2 [64]	0	0	0	1 [25]	3 [76]	6 [152] ③	140 [63.5]

NOTES: ① May require a 3" [76 mm] to 4" [102 mm] or 3" [76 mm] to 5" [127 mm] adapter.

② May be 0" [0 mm] with type B vent.

③ May be 1" [25 mm] with type B vent.

Furnaces must be vented in accordance with the National Fuel Gas Code, ANSI Z223.1 and/or Can/CGA-B149 Installation Codes and in accordance with local codes.

[ ] Designates Metric Conversions

# HORIZONTAL DIMENSIONS

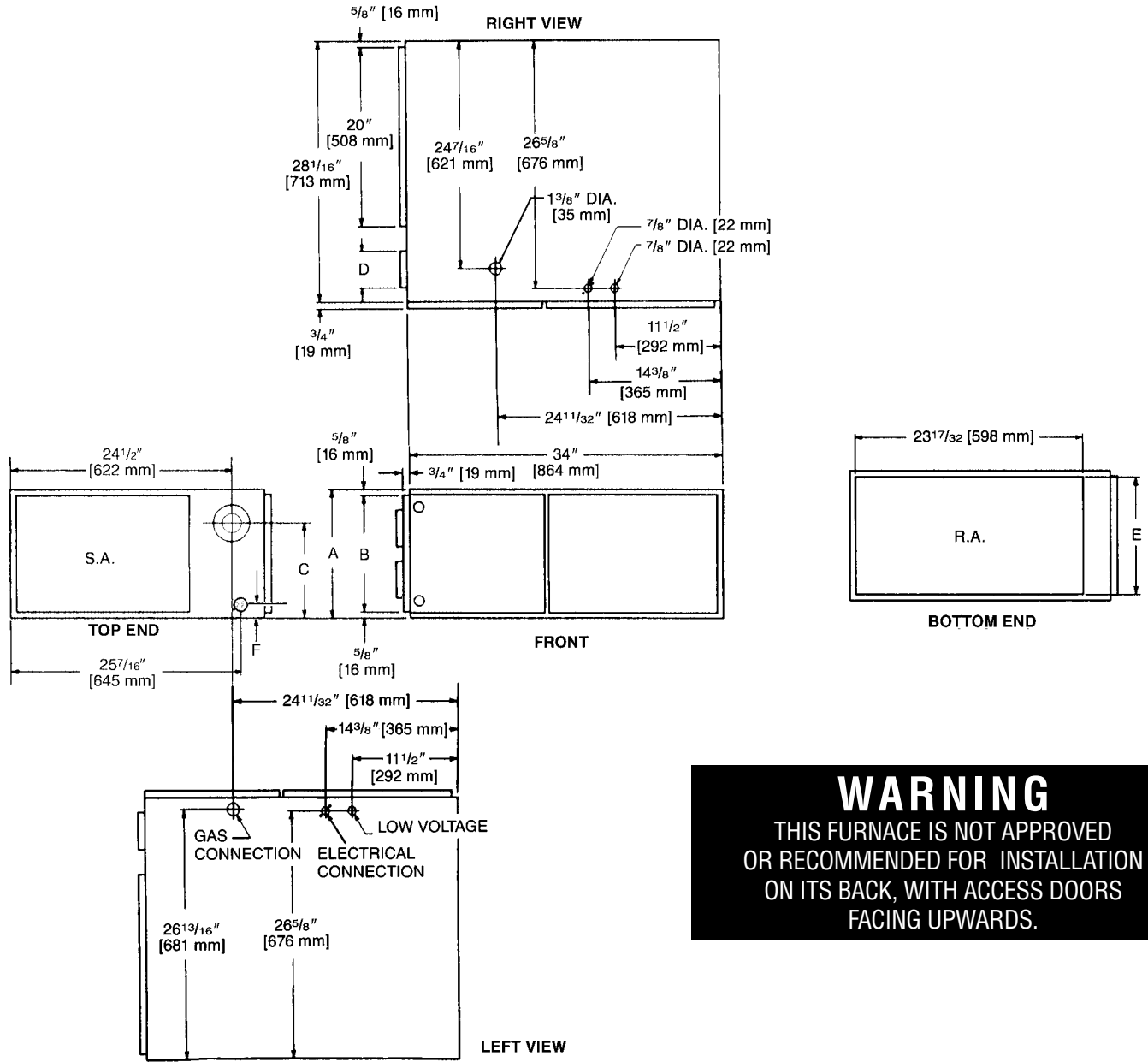

**WARNING**  
 THIS FURNACE IS NOT APPROVED OR RECOMMENDED FOR INSTALLATION ON ITS BACK, WITH ACCESS DOORS FACING UPWARDS.

## HORIZONTAL DIMENSIONS AND CLEARANCE TO COMBUSTIBLE MATERIAL (INCHES) [mm]

MODEL RGPT-	A	B	C	D	E	F	REDUCED CLEARANCES (IN.) [mm]						
							LEFT SIDE	RIGHT SIDE	BACK	TOP	FRONT	VENT	SHIP. WGTs. (LBS.) [kg]
05	17 1/2 [445]	16 11/32 [415]	12 9/8 [314]	Ⓢ	15 [381]	2 1/2 [63]	0	3 [76] ②	0	1 [25]	3 [76]	6 [152] ③	120 [54.4]
07 (A)	17 1/2 [445]	16 11/32 [415]	12 9/8 [314]	Ⓢ	15 [381]	2 1/2 [63]	0	3 [76] ②	0	1 [25]	3 [76]	6 [152] ③	120 [54.4]
07 (B)	21 [533]	19 27/32 [504]	14 1/8 [359]	Ⓢ	18 1/2 [470]	2 1/2 [63]	0	0	0	1 [25]	3 [76]	6 [152] ③	120 [54.4]
10	21 [533]	19 27/32 [504]	14 1/8 [359]	Ⓢ	18 1/2 [470]	2 1/2 [63]	0	0	0	1 [25]	3 [76]	6 [152] ③	120 [54.4]
12	24 1/2 [622]	23 11/32 [593]	15 7/8 [403]	Ⓢ	22 [559]	2 1/2 [63]	0	0	0	1 [25]	3 [76]	6 [152] ③	140 [63.5]

NOTES: ① May require a 3" [76 mm] to 4" [102 mm] or 3" [76 mm] to 5" [127 mm] adapter.

② May be 0" [0 mm] with type B vent.

③ May be 1" [25 mm] with type B vent.

Furnaces must be vented in accordance with the National Fuel Gas Code, ANSI Z223.1 and/or Can/CGA-B149 Installation Codes and in accordance with local codes.

[ ] Designates Metric Conversions

# ACCESSORIES—UPFLOW

## EXTERNAL BOTTOM FILTER RACK: RXGF-CB

FILTER RACK FILTER SIZES† INCHES [mm]	
MODEL RGPT-	RXGF-CA (SIDE)
05, 07(A), 07(B)	15 <sup>3</sup> / <sub>4</sub> x 25 [400 x 635]
10	15 <sup>3</sup> / <sub>4</sub> x 25 [400 x 635]
12	15 <sup>3</sup> / <sub>4</sub> x 25 [400 x 635]

† Filter racks are shipped without filters.

Filters shipped with furnace may be used or a suitable 1" [25.4 mm] filter.

\*Designates "E" or "N".

## RXPF-F01 and F02

**FOSSIL FUEL KITS** are for use with Rheem Classic Heat Pumps and Super Quiet 80 warm air furnaces. The RXPF-F02 meets TVA requirements.

### ACCESSORY RETURN AIR CABINETS

Return Air Cabinets may be installed on either side application except RXGR-C24B (side application must be on side opposite gas and electrical connections).

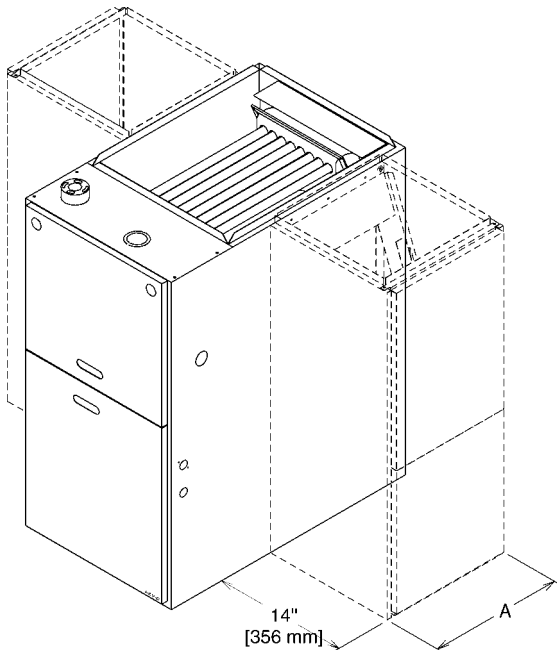

**THE RXGR-C24B MUST ONLY BE INSTALLED ON THE SIDE OPPOSITE THE GAS AND ELECTRICAL CONNECTIONS.**

RETURN AIR CABINETS	A IN. [mm]	FILTER SIZE IN. [mm]
RXGR-C14B	14 [356]	(2) 12 x 16 [305 x 406]
RXGR-C17B	17 <sup>1</sup> / <sub>2</sub> [445]	(2) 12 x 16 [305 x 406]
RXGR-C21B	21 [533]	(2) 20 x 16 [508 x 406]
RXGR-C24B	24 <sup>1</sup> / <sub>2</sub> [622]	(2) 24 x 16 [610 x 406]

### WARNING: IMPORTANT NOTICE

A SOLID METAL BASE PLATE (SEE TABLE) MUST BE IN PLACE WHEN THE FURNACE IS INSTALLED WITH SIDE AIR RETURN DUCTS. FAILURE TO INSTALL A BASE PLATE COULD CAUSE PRODUCTS OF COMBUSTION TO BE CIRCULATED INTO THE LIVING SPACE AND CREATE POTENTIALLY HAZARDOUS CONDITIONS.

FURNACE WIDTH IN. [mm]	SOLID BOTTOM KIT NO.	BASE PLATE NO.	BASE PLATE SIZE IN. [mm]
14 [356]	RXGB-D14	AE-61874-01	11 <sup>5</sup> / <sub>8</sub> x 23 <sup>9</sup> / <sub>16</sub> [295 x 598]
17 <sup>1</sup> / <sub>2</sub> [445]	RXGB-D17	AE-61874-02	15 <sup>1</sup> / <sub>8</sub> x 23 <sup>9</sup> / <sub>16</sub> [384 x 598]
21 [533]	RXGB-D21	AE-61874-03	18 <sup>5</sup> / <sub>8</sub> x 23 <sup>9</sup> / <sub>16</sub> [473 x 598]
24 <sup>1</sup> / <sub>2</sub> [622]	RXGB-D24	AE-61874-04	25 <sup>5</sup> / <sub>8</sub> x 23 <sup>9</sup> / <sub>16</sub> [651 x 598]

## FOR HIGH ALTITUDES:

**OPTION CODE FOR HIGH ALTITUDE:** U.S. & Canada

None required for high altitudes.

**HIGH ALTITUDE CONVERSION KITS:** U.S. & Canada

None required for high altitudes.

### 80+ HIGH ALTITUDE INSTRUCTIONS

**CAUTION:** Always follow National Fuel Gas Code (NFGC) guidelines when converting for high altitudes.

High altitude option codes are not required for these models. However, the burner orifice size needs to be recalculated and verified at elevations above 2000 ft. See Installation Instructions for more information.

**NOTE:** For Canadian installations only, an optional derate (manifold gas pressure reduction) method may be used to adjust the furnace for altitude. See Installation Instructions for more information. This optional method may **NOT** be used for U.S. installations.

[ ] Designates Metric Conversions

# BLOWER PERFORMANCE DATA—UPFLOW/HORIZONTAL MODELS

MODEL NUMBER RGPT-SERIES	BLOWER SIZE in INCHES [mm] (D x L)	MOTOR H.P. [W]	BLOWER SPEEDS	WIRE COLOR	MOTOR OUTPUT NUMBER	CFM [L/s] AIR DELIVERY EXTERNAL STATIC PRESSURE INCHES [kPa] WATER COLUMN					
						.1 [.02]	.2 [.05]	.3 [.07]	.5 [.12]	.6 [.15]	.8 [2.0]
05EBMKR, 05NBMKR	11 x 7 [279 x 178]	3/4 [559]	LOW	RED	1	727 [343]	687 [324]	636 [300]	542 [255]	513 [242]	443 [209]
			MED-LO*	YELLOW*	2*	946 [446]	915 [431]	879 [414]	823 [388]	793 [374]	717 [338]
			MED	PURPLE	3	1169 [551]	1136 [536]	1102 [520]	1048 [494]	1025 [483]	974 [459]
			MED-HI	BLUE	4	1334 [629]	1306 [616]	1278 [603]	1225 [578]	1200 [566]	1134 [535]
			HIGH	BLACK	5	1657 [782]	1611 [760]	1572 [741]	1474 [695]	1433 [676]	1319 [622]
07EAMKR, 07NAMKR	11 x 7 [279 x 178]	1/2 [373]	LOW	RED	1	840 [396]	717 [338]	634 [299]	545 [257]	495 [233]	400 [188]
			MED-LO	YELLOW	2	992 [468]	945 [446]	909 [429]	831 [392]	783 [369]	702 [331]
			MED*	PURPLE*	3*	1214 [573]	1176 [555]	1129 [532]	1053 [497]	1022 [482]	940 [443]
			MED-HI	BLUE	4	1375 [649]	1338 [631]	1308 [617]	1239 [584]	1200 [566]	1128 [532]
			HIGH	BLACK	5	1488 [702]	1452 [685]	1422 [671]	1352 [638]	1316 [621]	1248 [589]
07EBRQR, 07NBRQR	11 x 10 [279 x 254]	1 [746]	LOW	RED	1	1173 [553]	1101 [519]	1033 [487]	918 [433]	881 [415]	763 [360]
			MED-LO*	YELLOW*	2*	1415 [667]	1356 [640]	1311 [618]	1211 [571]	1150 [542]	1049 [495]
			MED	PURPLE	3	1628 [768]	1580 [745]	1537 [725]	1453 [685]	1414 [667]	1322 [623]
			MED-HI	BLUE	4	1942 [916]	1906 [899]	1857 [876]	1783 [841]	1723 [813]	1636 [772]
			HIGH	BLACK	5	2422 [1143]	2387 [1126]	2351 [1109]	2207 [1041]	2144 [1011]	1984 [936]
10EBRMR, 10NBRMR	11 x 10 [279 x 254]	1 [746]	LOW	RED	1	1177 [555]	1110 [523]	1044 [492]	933 [440]	888 [419]	785 [370]
			MED-LO	YELLOW	2	1396 [658]	1351 [637]	1297 [612]	1200 [566]	1149 [542]	1053 [497]
			MED	PURPLE	3	1607 [758]	1572 [741]	1526 [720]	1445 [682]	1408 [664]	1320 [623]
			MED-HI*	BLUE*	4*	1916 [904]	1879 [886]	1833 [865]	1760 [830]	1695 [800]	1622 [765]
			HIGH	BLACK	5	2305 [1087]	2274 [1073]	2229 [1052]	2160 [1019]	2107 [994]	1969 [929]
12EARMR, 12NARMR	11 x 10 [279 x 254]	1 [746]	LOW	RED	1	1173 [553]	1041 [491]	968 [456]	851 [401]	799 [377]	684 [322]
			MED-LO	YELLOW	2	1322 [623]	1274 [601]	1211 [571]	1089 [514]	1056 [498]	951 [448]
			MED	PURPLE	3	1560 [736]	1490 [703]	1447 [682]	1357 [640]	1311 [618]	1228 [579]
			MED-HI*	BLUE*	4*	1913 [902]	1871 [883]	1827 [862]	1730 [816]	1686 [795]	1606 [758]
			HIGH	BLACK	5	2435 [1149]	2394 [1129]	2363 [1115]	2258 [1065]	2186 [1031]	2019 [952]

NOTES: \* = FACTORY HEATING SPEED  
 = NOT TO BE USED AS HEATING SPEED

[ ] Designates Metric Conversions

## GENERAL TERMS OF LIMITED WARRANTY

Rheem will furnish a replacement for any part of this product which fails in normal use and service within the applicable period stated, in accordance with the terms of the limited warranty.

Gas Heat Exchanger Limited Warranty ..... Twenty (20) Years  
 Conditional Parts\* (Registration Required) ..... Ten (10) Years

\*For Complete Details of the Limited Warranty, Including Applicable Terms and Conditions, See Your Local Installer or Contact the Manufacturer for a Copy.

**Before proceeding with installation, refer to installation instructions packaged with each model, as well as complying with all Federal, State, Provincial, and Local codes, regulations, and practices.**

**Rheem Heating,  
Cooling and  
Water Heating**

P.O. Box 17010, Fort Smith, AR 72917



*"In keeping with its policy of continuous progress and product improvement, Rheem reserves the right to make changes without notice."*