

14AJL 18, 24, 30,
36, 42, 48, 60

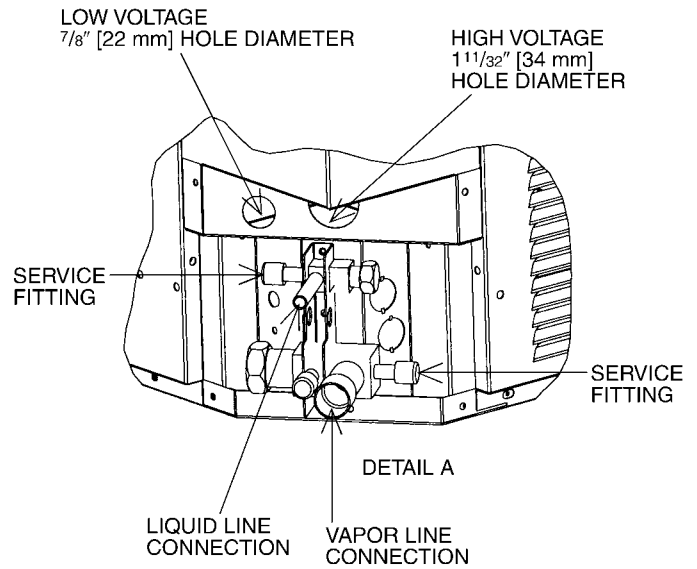
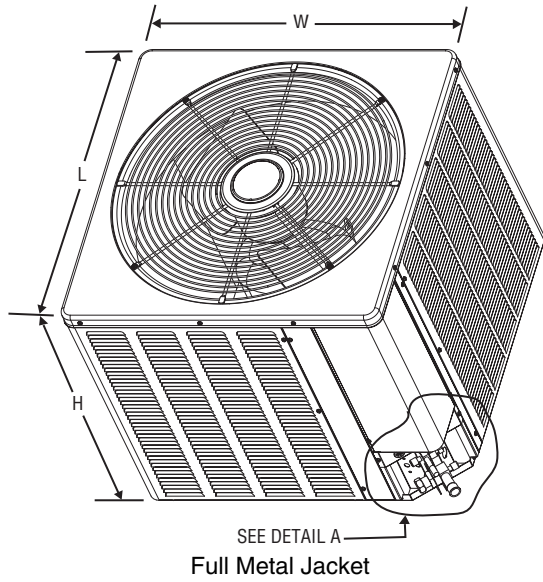

| Model No. 14AJL | Unit Dimensions | | |
|--------------------|--------------------------------------|--------------------------------------|--------------------------------------|
| | Width "W" Inches [mm] | Length "L" Inches [mm] | Height "H" Inches [mm] |
| 18, 24 | 27 ⁵ / ₈ [702] | 27 ⁵ / ₈ [702] | 24 ¹ / ₄ [616] |
| 30 | 31 ⁵ / ₈ [803] | 31 ⁵ / ₈ [803] | 27 ³ / ₈ [695] |
| 36, 42, 48, 60 | 31 ⁵ / ₈ [803] | 31 ⁵ / ₈ [803] | 35 ³ / ₈ [899] |

[] Designates Metric Conversions

Before proceeding with installation, refer to installation instructions packaged with each model, as well as complying with all Federal, State, Provincial, and Local codes, regulations, and practices.

"In keeping with its policy of continuous progress and product improvement, Manufacturer reserves the right to make changes without notice."