

**Commercial
High-Efficiency
Remote Heat Pumps
RPWE -090 & -120 Series**



**7.5 & 10 TON MODEL
[26 & 35 kW]**



**CERTIFIED UNDER THE
A.R.I. CERTIFICATION
PROGRAM—A.R.I.
STANDARD 340**



**7.5 & 10 NOMINAL TON UNITS
[26 & 35 kW]**



TABLE OF CONTENTS

Model Number Designation	2	Cooling & Heating Performance Data	8-9
Accessories	2	Piping	10
Standard Unit Features	3-4	Airflow Correction Factors	11
Physical Data Table	5	General Installation.....	11
Performance Ratings	5	Typical Field Wiring Connections.....	12
Electrical Data Table.....	5	Sequence of Operation	13
Unit Dimensions	5-6	Guide Specifications	14
Selection Procedure	7	Limited Warranty	14

WHY USE A HIGH EFFICIENCY, AIR COOLED REMOTE HEAT PUMP SYSTEM?

- The size ranges offered by Rheem® allow you to mix or match components to meet actual job requirements, thus eliminating the need to use oversized or undersized equipment. Equipment sized to meet the actual load will provide better operating economy, better humidity control, and longer equipment life.
- With an air cooled system, you have no water or sewer connections to make, and no troublesome and costly water treatment problems.
- Since the Remote Heat Pump unit is located outside the building, and the low profile air handling unit can be installed in the drop ceiling or in the conditioned space, you will not need a separate equipment room which takes up valuable building space.
- Remote mounting of the already quiet heat pump unit keeps the compressor and condenser fan noise outside, and the vertical discharge fans carry the sound up and away from the surrounding area.
- Because of the simple design of the Rheem Remote Heat Pump unit, installation is quick and simple, and very little maintenance is required.
- Energy Efficiency Ratings (EER's) to 10.3!

[] Designates Metric Conversions

MODEL NUMBER DESIGNATION

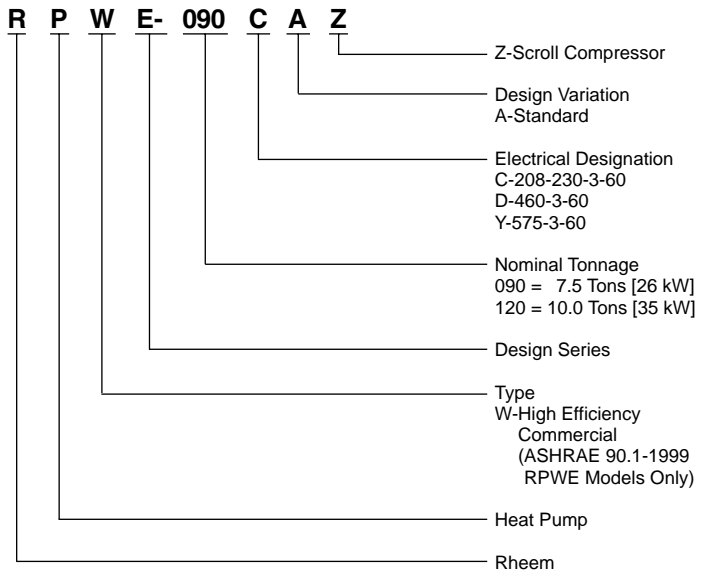

FIELD-INSTALLED HEAT PUMP UNIT ACCESSORIES

ACCESSORY DESCRIPTION	MODEL NUMBER
Sight Glass	RXAG-A048
Suction Line Service Valve*	RXMV-AD
Outdoor Thermostat	RXPT-A01
Fossil Fuel Kit	RXPF-C01

*Also available factory installed (option code 956).

STANDARD UNIT FEATURES



1. **BASE RAILS**—Commercial grade base rails for handling any rigging.
2. **HIGH PRESSURE CONTROL**—Manual reset control deactivates system if abnormally high pressure occurs.
3. **CABINET**—Galvanized steel with powder coat paint finish. The powder coat paint finish is high gloss, durable and capable of withstanding a 1000-hour salt spray test per ASTM B 117. The unit is of the frame and panel type of construction secured by 1000-hour screws. This allows all access panels to be opened or removed without affecting the structural strength of the unit. Stamped louvered panels offer 100% protection for the condenser coil.

CONTROL BOX

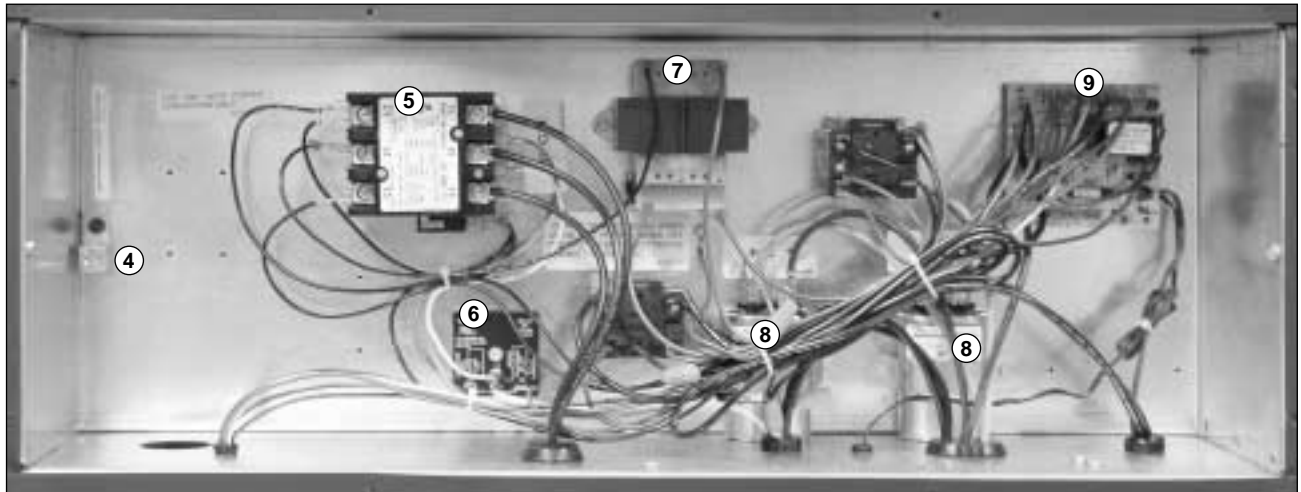

4. **EQUIPMENT GROUND**—Lug for field connection of ground wire.
5. **CONTACTOR**—The contactor is an electrical switch which operates the compressor and outdoor fans. Its 24 volt coil is activated on a call for cooling or heating.
6. **ANTI-SHORT CYCLE TIMER**—Prevents restarting of unit for 5 minutes if shut down for any reason.
7. **TRANSFORMER**—75 VA step-down type, from Line to 24 volts with resettable circuit breaker.
8. **CAPACITORS**—Help provide starting torque necessary to boost the condenser fan motors to operating speed by directing their stored energy to the starter winding in step with the running winding.
9. **DEMAND DEFROST CONTROL**—Used when unit is in heating mode to defrost outdoor coil.

STANDARD UNIT FEATURES (cont.)

UNIT INTERIOR-TOP VIEW

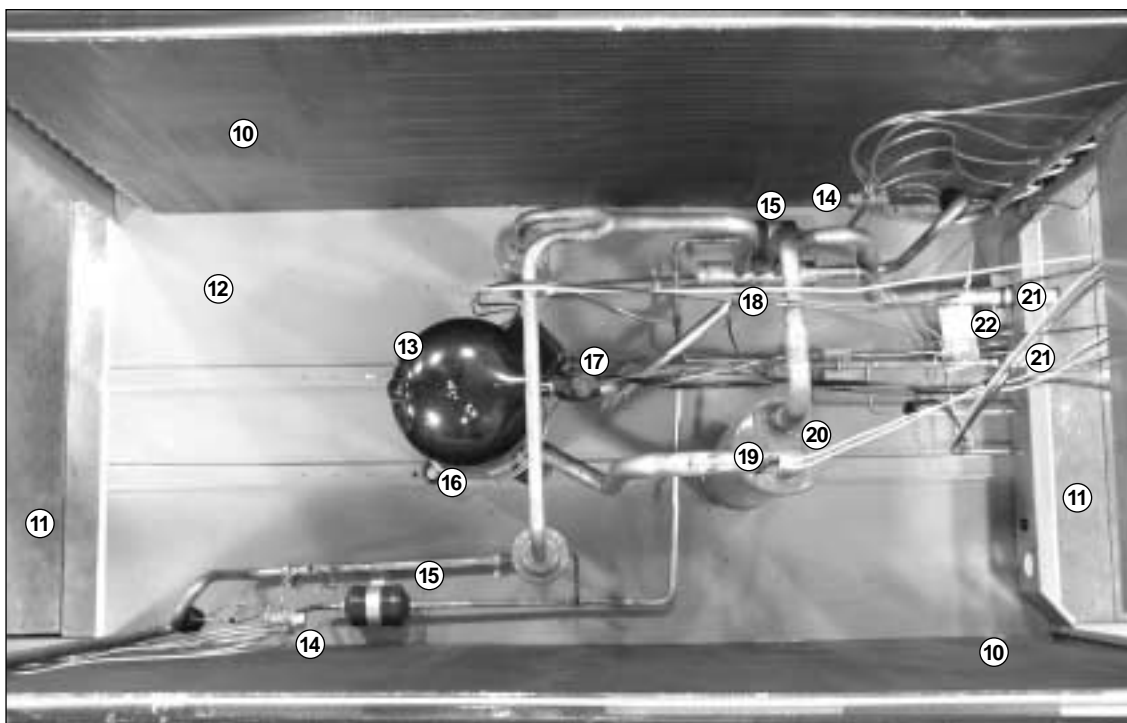

- 10. **COILS**—Constructed with copper tubes and aluminum fins mechanically bonded to tubes for maximum heat transfer capabilities. All coil assemblies are leak tested up to 300 PSIG [2068 kPa] internal pressure.
- 11. **SERVICE ACCESS**—Control box with separate line and control voltages, as well as compressor and other refrigerant controls are accessible through access panels. An electrical access cover may be opened or removed without affecting normal operation of the unit. Condenser fan motors are equipped with molded plugs for easy removal. Louver panels and end access panel can be removed for coil cleaning.
- 12. **BASE PAN**—Galvanized steel with powder coat paint finish.
- 13. **COMPRESSOR**—The Scroll Compressor is hermetically sealed with internal high temperature protection, and durable insulation on motor windings. The entire compressor is mounted on rubber grommets to reduce vibration and noise.
- 14. **TX VALVE**—Used when unit is in heating mode and outdoor coil functions as evaporator.

- 15. **FILTER DRIER**—Installed in liquid line.
- 16. **CRANKCASE HEATER**—Minimizes refrigerant migration to compressor sump.
- 17. **HOT GAS SENSOR (Discharge Line Thermostat)**—Control prevents damage to compressor under abnormal conditions; loss of charge protection.
- 18. **REVERSING VALVE**—Sized for maximum capacity and efficiency, 24V coil, energized in heating.
- 19. **LOW PRESSURE CONTROL**—Automatic reset control deactivates system if refrigerant loss occurs. Located in suction line.
- 20. **SUCTION LINE ACCUMULATOR**—To prevent liquid slugging of compressor.
- 21. **REFRIGERANT CONNECTIONS**—All field sweat joints are made external of the unit and are located close to the ground for a neat looking installation.
- 22. **SERVICE VALVE**—Standard on liquid line, optional on vapor line.



CONDENSER FAN MOTORS—Direct drive, single-phase permanently lubricated “PSC” motors with inherent overload protection.

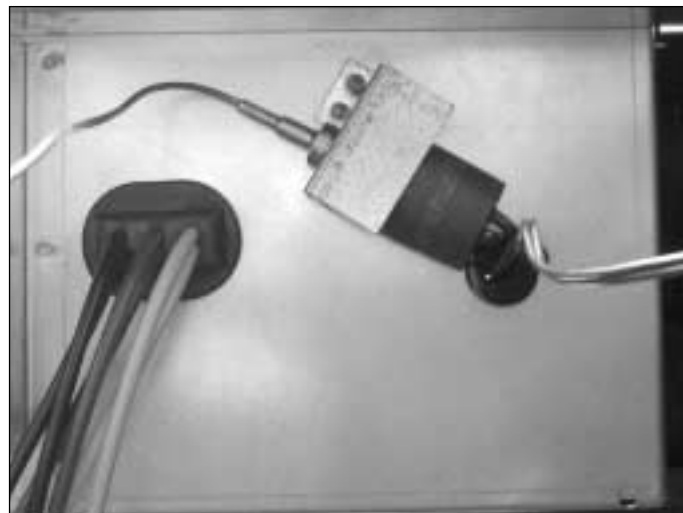

LOW AMBIENT CONTROL—A pressure sensitive fan cycling control allows cooling operation of unit down to 0°F [-18°C].

UNIT DIMENSIONS

CORNER WEIGHTS (LBS.) [kg]

MODEL	A	B	C	D
RPWE-090	133 [60.3]	145 [65.8]	151 [68.5]	139 [63.0]
RPWE-120	167 [75.7]	160 [72.6]	160 [72.6]	167 [75.7]
TOTAL WEIGHT; 090 = 568 LBS. [257.6 kg], 120 = 654 LBS. [296.6 kg]				

PHYSICAL DATA TABLE

MODEL NO. RPWE-	090	120
Capacity (tons) [kW]	7.5 [26]	10 [35]
Operating Weight (lbs.) [kg]	569 [258.1]	655 [297.1]
Shipping Weight (lbs.) [kg]	600 [272.2]	695 [315.2]
COMPRESSOR:		
Quantity	1	1
Type	Hermetic Scroll	
RPM	3500	
CONDENSER FANS:		
Quantity	2	2
CFM [L/s]	7400 [3492]	7400 [3492]
Diameter (in.) [mm]/Blades	24 [609.6]/3	24 [609.6]/3
Drive	Direct	
Motor Horsepower (ea.) [W]	1/3 [248.6]	1/3 [248.6]
Type	PSC	PSC
RPM	1075	1075
CONDENSER COIL:		
Quantity	2	2
Rows	2	2
Fins per Inch Straight/Enhanced	18	22
Square Feet [m ²]	27 [2.5]	32 [3.0]
Fins/Tubes	Aluminum/Copper	
Tube Size, O.D. (in.) [mm]	3/8 [9.5]	3/8 [9.5]
REFRIGERANT CONN.:		
Suction O.D. (in.) [mm]		
Sweat	1 1/8 [28.6]	1 3/8 [34.9]
Liquid O.D. (in.) [mm]	1/2 [12.7]	5/8 [15.9]
CABINET:		
Finish	Powder Coat	
Sheet Metal	Galvanized	
Gauge (nominal)		
Top	20	20
Sides	20	20
Base Rails	14	14

ELECTRICAL DATA TABLE

MODEL NO. RPWE-	090	090	090	120	120	120
COMPRESSOR MOTOR:	208/230-	460-3-60	575-3-60	208/230-	460-3-60	575-3-60
Electrical Characteristics	3-60			3-60		
OPERATING CURRENT:						
Rated Load Amps*	28.8	14.7	10.9	38.6	20.3	15.7
Locked Rotor Amps*	195	95	80	239	125	80
CONDENSER FAN MOTORS:	208/230-1	460-1	575-1	208/230-1	460-1	575-1
Volts & Phase						
Full Load Amps (each)	2.4	1.4	1.0	2.4	1.1	0.8
SYSTEM CHARACTERISTICS:						
Unit FLA*	33.6	17.5	12.9	43.4	22.4	17.2
Minimum Circuit Ampacity*	41	22	16	57	30	23
Max. Fuse Size (Amps)*	60	35	25	90	50	35
Wire Size 50'/100'	6/4	10/8	14/10	6/4	10/6	10/8
Disconnect Size	60	60	30	100	60	60

NOTE: Local codes take precedence over suggested wire and fuse sizes.

*Values shown are the most severe and may vary slightly depending on compressor model supplied.

NET PERFORMANCE RATED AND CERTIFIED WITH ARI STANDARD 340

MODEL	ARI COOLING PERFORMANCE						ARI HEATING PERFORMANCE (70°F [21.0°C] INDOOR)					
	80°F [26.5°C] DB/67°F [19.5°C] WB INDOOR AIR 95°F [35.0°C] DB OUTDOOR AIR						OUTDOOR AIR 47°F DB/43°F WB [8.5°C/6.0°C] DOE HIGH TEMP.			OUTDOOR AIR 17°F DB/15°F WB [-8.5°C/-9.5°C] DOE LOW TEMP.		
	TOTAL BTU/H [kW]	NET SENS. BTU/H [kW]	NET LATENT BTU/H [kW]	EER	RATED CFM [L/s]	SOUND RATING (dB)	BTU/H [kW]	TOTAL WATTS	COP	BTU/H [kW]	TOTAL WATTS	COP
RPWE-090 (RHGG-120) ①	92,000 [26.96]	69,000 [20.22]	23,000 [6.74]	10.30	3200 [1510]	88	89,000 [26.08]	7,490	3.20	49,000 [14.36]	6,600	2.20
RPWE-120 (RHGG-120) ①	120,000 [35.17]	85,500 [25.06]	34,500 [10.11]	10.10	3700 [1746]	88	119,000 [34.88]	10,640	3.20	69,000 [20.22]	9,112	2.20

① Highest sales volume tested combination required by DOE Test Procedures.

[] Designates Metric Conversions

UNIT DIMENSIONS (con't.)

CORNER WEIGHTS (PERCENTAGE)

MODEL	A	B	C	D
RPWE-090	23%	26%	27%	25%
RPWE-120	26%	24%	26%	24%

CENTER OF GRAVITY

MODEL	X"	Y"
RPWE-090	31.2	18.9
RPWE-120	31.2	18.9

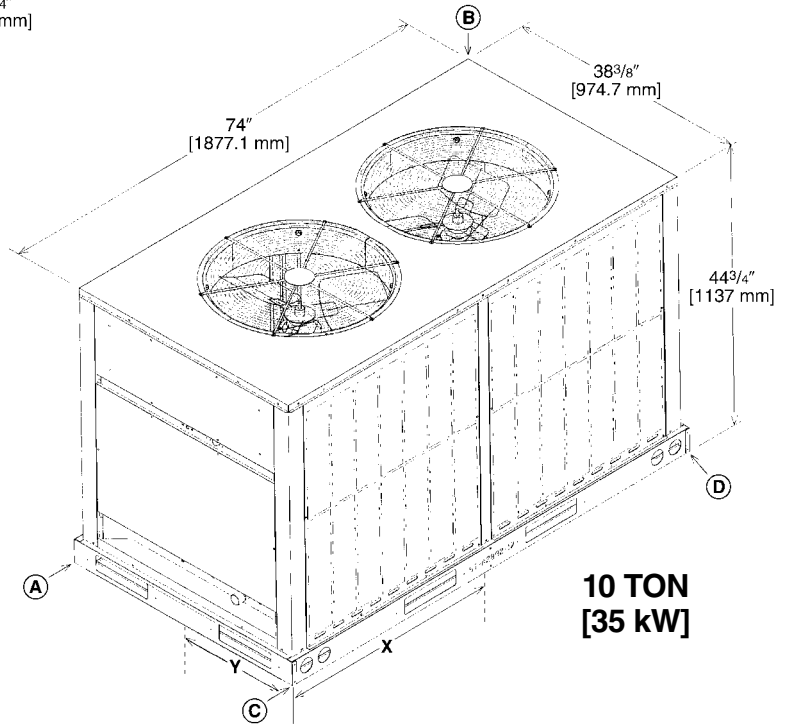
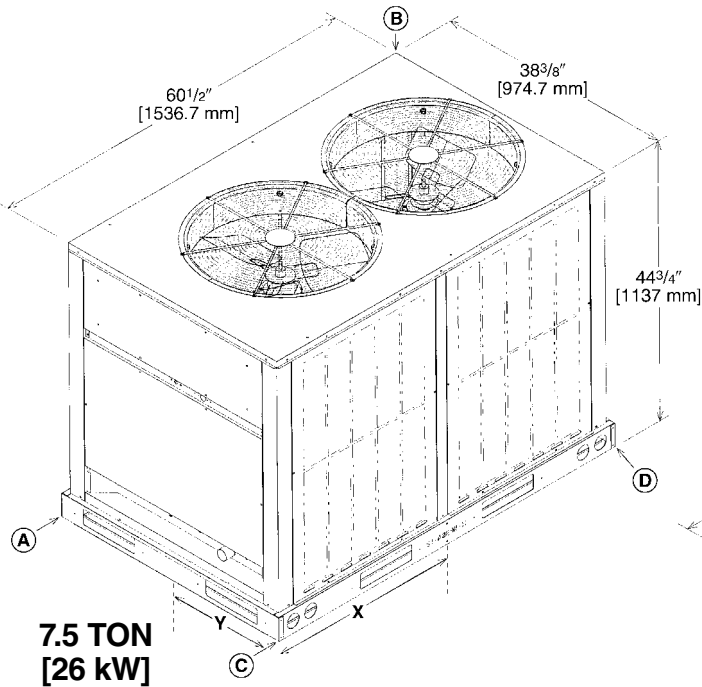

7.5 TON [26 kW] & 10 TON [35 kW]

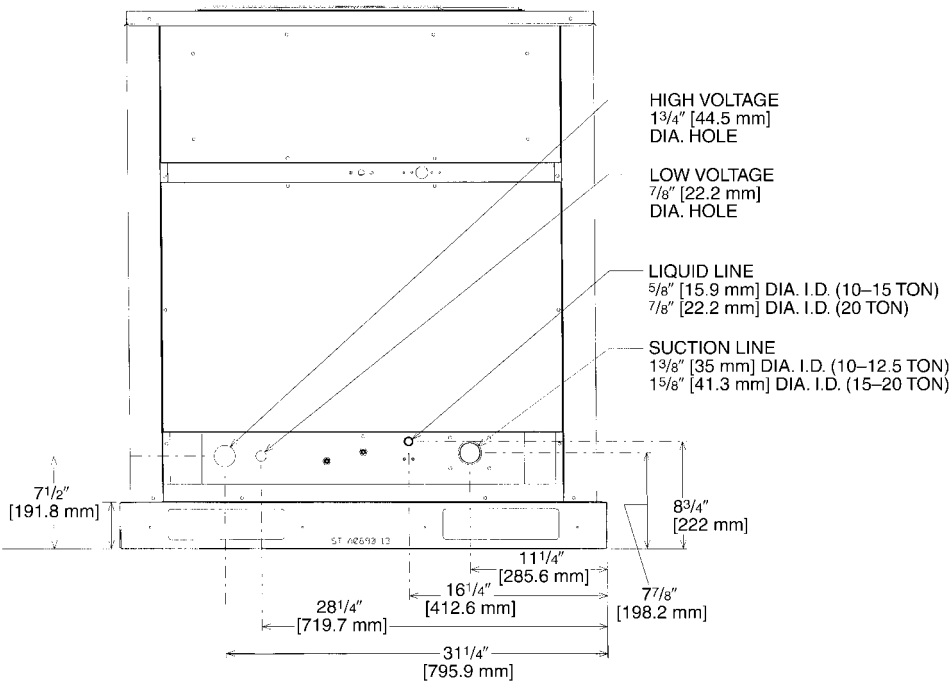

SELECTION PROCEDURE

To select an RPWE- Heat Pump unit to meet a job requirement, follow this procedure.

1. DETERMINE COOLING AND HEATING REQUIREMENTS AND SPECIFIC OPERATING CONDITIONS FROM PLANS AND SPECS.

Example: Total cooling capacity—	84,000 BTUH [24.61 kW]
Sensible cooling capacity—	68,000 BTUH [19.92 kW]
Heating capacity—	120,000 BTUH [35.16 kW]
*Condenser Entering Air—	95°F [35°C] DB
*Evaporator Mixed Air Entering	78°F [26°C] DB; 65°F [18°C] WB
*Indoor Air Flow (vertical)	3000 CFM [1416 L/s]
*External Static Pressure	.5 in. WG
Available Power	240 V, 3 PH

2. SELECT UNIT TO MEET COOLING REQUIREMENTS.

Since total cooling is within the range of a nominal 7.5 ton [26.4 kW] unit, enter cooling performance table at 95°F [35°C] DB condenser inlet air. Interpolate between 63°F [2°C] and 67°F [19°C] to determine total and sensible capacity and power input for 65°F [18°C] WB evap inlet air at 3200 CFM [1510 L/s] indoor air flow (table basis):

Total Capacity = 90,450 BTUH [26.5 kW]
Sensible Capacity = 78,150 BTUH [22.9 kW]
Power Input (Compressor and Cond. Fans) = 7,750 Watts

Use formula in note ① on the cooling performance table to determine sensible capacity at 78°F [26°C] DB evaporator entering air:

Sensible Capacity = 72,300 BTUH [21.2 kW]

3. CORRECT CAPACITIES OF STEP 2 FOR ACTUAL AIR FLOW.

Select factors from airflow correction table on Page 11 at 3000 CFM [1416 L/s] and apply to data obtained in step 2 to obtain gross capacity:

Total Capacity = 90,450 x .99 = 89,540 BTUH [26.23 kW]
Sensible Capacity = 72,300 x .97 = 70,130 BTUH [20.54 kW]
Power Input = 7,750 x 1.00 = 7,750 Watts

These are Gross Capacities, not corrected for blower motor heat or power.

4. DETERMINE BLOWER SPEED AND WATTS TO MEET SYSTEM DESIGN.

In the “Commercial Air Handler Specification Sheet” (Form #H11-514) follow the bold line example on the “Blower Performance Curve – 10 ton (wet coil)”. Enter the graph at 3000 CFM [1416 L/s]. Determine which “number of turns” line is closest to the intersection of 0.5 IN [.12 kPa] static and 3000 CFM [1416 L/s]. In this case 4 turns is the closest. Continue following the 3000 CFM line to the next intersection of 4 turns. From this intersection draw a line to the right to determine the watts.

WATTS = 950

5. CALCULATE INDOOR BLOWER BTUH HEAT EFFECT FROM MOTOR WATTS, STEP 4.

HEAT = 950 x 3.412 = 3,240 BTUH

6. CALCULATE NET COOLING CAPACITIES, EQUAL TO GROSS CAPACITY, STEP 3, MINUS INDOOR BLOWER MOTOR HEAT.

Net Total Capacity = 89,540 – 3,240 = 86,300 BTUH [25.28 kW]
Net Sensible Capacity = 70,130 – 3,240 = 66,890 BTUH [19.59 kW]

7. CALCULATE UNIT INPUT AND JOB EER.

Total Power Input = 7,750 (step 3) + 950 (step 4) = 8,700 Watts

$$EER = \frac{\text{Net Total BTUH [kW] (step 6)}}{\text{Power Input, Watts (above)}} = \frac{86,300}{8,700} = 9.9$$

8. SELECT UNIT HEATING CAPACITY.

In the “Commercial Air Handler Specification Sheet” (Form #H11-514) turn to the “electrical heater kit characteristics table,” find a heater kit that is compatible with a 7.5 ton unit that has minimum of 120,000 BTUH. The RXHE-DE040CA [40 kW] has a capacity of 136,500 BTUH at 240 V.

*NOTE: These operating conditions are typical of a commercial application in a 95°F/79°F [35°C/26°C] design area with indoor design of 76°F [24°C] DB and 50% RH and 10% ventilation air, with the unit mounted and centered on the zone it conditions by ducts.

[] Designates Metric Conversions

COOLING PERFORMANCE DATA—RPWE-090/RHGG-120

ENTERING INDOOR AIR @ 80°F [26.7°C] dbE ①											
wbE		71°F [21.7°C]			67°F [19.4°C]			63°F [17.2°C]			
CFM [L/s]		3840 [1812]	3200 [1510]	2560 [1208]	3840 [1812]	3200 [1510]	2560 [1208]	3840 [1812]	3200 [1510]	2560 [1208]	
DR ①		.20	.17	.13	.20	.17	.13	.20	.17	.13	
OUTDOOR DRY BULB TEMPERATURE °F [°C]	75 [23.9]	Total BTUH [kW] Sens BTUH [kW] Power	108.6 [99.15] 70.6 [20.69] 8.8	105.1 [30.80] 63.9 [18.73] 8.7	101.7 [29.81] 57.2 [16.76] 8.6	102.4 [30.01] 82.0 [24.03] 6.7	99.0 [29.01] 75.3 [22.07] 6.6	95.5 [27.99] 68.6 [20.10] 6.5	93.9 [27.52] 93.9 [27.52] 7.0	90.5 [26.52] 88.2 [25.85] 6.9	87.0 [25.50] 81.5 [23.89] 6.8
	80 [26.7]	Total BTUH [kW] Sens BTUH [kW] Power	107.1 [31.39] 70.1 [20.54] 9.1	103.6 [30.36] 63.4 [18.58] 8.9	100.2 [29.37] 56.7 [16.62] 8.8	100.9 [29.57] 81.5 [23.89] 7.0	97.5 [28.57] 74.8 [21.92] 6.9	94.0 [27.55] 68.1 [19.96] 6.7	92.4 [27.08] 92.4 [27.08] 7.3	89.0 [26.08] 87.7 [25.70] 7.1	85.5 [25.06] 81.0 [23.74] 7.0
	85 [29.4]	Total BTUH [kW] Sens BTUH [kW] Power	106.1 [31.09] 69.2 [20.28] 9.3	102.6 [30.07] 62.6 [18.35] 9.2	99.2 [29.07] 55.9 [16.38] 9.0	99.9 [29.28] 80.6 [23.62] 7.2	96.5 [28.28] 73.9 [21.66] 7.1	93.0 [27.26] 67.2 [19.69] 7.0	91.4 [26.79] 91.4 [26.79] 7.5	88.0 [25.79] 86.9 [25.47] 7.4	84.5 [24.76] 80.2 [23.50] 7.3
	90 [32.2]	Total BTUH [kW] Sens BTUH [kW] Power	105.2 [30.83] 68.2 [19.99] 9.5	101.8 [29.83] 61.5 [18.02] 9.4	98.3 [28.81] 54.8 [16.06] 9.3	99.1 [29.04] 79.6 [23.33] 7.5	95.6 [28.02] 72.9 [21.36] 7.4	92.2 [27.02] 66.2 [19.40] 7.2	90.6 [26.55] 90.6 [26.55] 7.8	87.1 [25.53] 85.8 [25.15] 7.6	83.7 [24.53] 79.1 [23.18] 7.5
	95 [35]	Total BTUH [kW] Sens BTUH [kW] Power	104.3 [30.57] 67.0 [19.64] 9.8	100.9 [29.57] 60.3 [17.67] 9.7	97.4 [28.55] 53.6 [15.71] 9.5	98.2 [28.78] 78.4 [22.98] 7.7	94.7 [27.75] 71.7 [21.01] 7.6	91.3 [26.76] 65.0 [19.05] 7.5	89.6 [26.26] 89.6 [26.26] 8.0	86.2 [25.26] 84.6 [24.79] 7.9	82.8 [24.27] 78.0 [22.86] 7.8
	100 [37.8]	Total BTUH [kW] Sens BTUH [kW] Power	103.0 [30.19] 65.9 [19.31] 10.0	99.5 [29.16] 59.3 [17.38] 9.9	96.1 [28.16] 52.6 [15.42] 9.8	96.8 [28.37] 77.3 [22.65] 8.0	93.4 [27.37] 70.6 [20.69] 7.9	90.0 [26.38] 63.9 [18.73] 7.7	88.3 [25.88] 88.3 [25.88] 8.3	84.9 [24.88] 83.6 [24.50] 8.1	81.4 [23.86] 76.9 [22.54] 8.0
	105 [40.6]	Total BTUH [kW] Sens BTUH [kW] Power	101.0 [29.60] 65.1 [19.08] 10.3	97.5 [28.57] 58.4 [17.12] 10.2	94.1 [27.58] 51.7 [15.15] 10.0	94.9 [27.81] 76.5 [22.42] 8.2	91.4 [26.79] 69.8 [20.46] 8.1	88.0 [25.79] 63.1 [18.49] 8.0	86.3 [25.29] 86.3 [25.29] 8.5	82.9 [24.30] 82.7 [24.24] 8.4	79.4 [23.27] 76.0 [22.27] 8.2
	110 [43.3]	Total BTUH [kW] Sens BTUH [kW] Power	98.0 [28.72] 64.6 [18.93] 10.5	94.6 [27.72] 57.9 [16.97] 10.4	91.1 [26.70] 51.2 [15.01] 10.3	91.9 [26.93] 75.9 [22.24] 8.5	88.5 [25.94] 69.2 [20.28] 8.4	85.0 [24.91] 62.5 [18.32] 8.2	83.4 [24.44] 83.4 [24.44] 8.7	79.9 [23.42] 79.9 [23.42] 8.6	76.5 [22.42] 75.5 [22.13] 8.5
	115 [46.1]	Total BTUH [kW] Sens BTUH [kW] Power	93.8 [27.49] 64.5 [18.90] 10.8	90.4 [26.49] 57.8 [16.94] 10.7	86.9 [25.47] 51.2 [15.01] 10.5	87.7 [25.70] 75.9 [22.24] 8.7	84.3 [24.71] 69.2 [20.28] 8.6	80.8 [23.68] 62.5 [18.32] 8.5	79.2 [23.21] 79.2 [23.21] 9.0	75.7 [22.19] 75.7 [22.19] 8.9	72.3 [21.19] 72.3 [21.19] 8.7

DR —Depression ratio
dbE —Entering air dry bulb
wbE—Entering air wet bulb

Total —Total capacity x 1000 BTUH
Sens —Sensible capacity x 1000 BTUH
Power—kW input

NOTES:

① When the entering air dry bulb is other than 80°F [27°C], adjust the sensible capacity from the table by adding $[1.10 \times \text{CFM} \times (1 - \text{DR}) \times (\text{dbE} - 80)]$.

HEATING PERFORMANCE DATA—RPWE-090/RHGG-120

IDB		60°F [15.5°C]			70°F [21.1°C]			80°F [26.7°C]			
CFM [L/s]		3600 [1699]	3000 [1416]	2400 [1133]	3600 [1699]	3000 [1416]	2400 [1133]	3600 [1699]	3000 [1416]	2400 [1133]	
OUTDOOR DRY BULB TEMPERATURE °F [°C]	0 [-17.8]	Total BTUH [kW] Power	44.0 [12.89] 5.6	42.8 [12.54] 5.8	41.6 [12.19] 6.0	41.8 [12.25] 6.0	40.6 [11.90] 6.2	39.3 [11.51] 6.3	35.6 [10.43] 6.0	34.4 [10.08] 6.1	33.2 [9.73] 6.3
	5 [-15]	Total BTUH [kW] Power	46.8 [13.71] 5.7	45.6 [13.36] 5.9	44.4 [13.01] 6.1	44.5 [13.04] 6.1	43.3 [12.69] 6.3	42.1 [12.34] 6.4	38.3 [11.22] 6.1	37.1 [10.87] 6.2	35.9 [10.52] 6.4
	10 [-12.2]	Total BTUH [kW] Power	50.8 [14.88] 5.8	49.6 [14.53] 6.0	48.4 [14.18] 6.2	48.5 [14.21] 6.2	47.3 [13.86] 6.4	46.1 [13.51] 6.5	42.3 [12.39] 6.2	41.1 [12.04] 6.3	39.9 [11.69] 6.5
	15 [-9.4]	Total BTUH [kW] Power	55.7 [16.32] 5.9	54.5 [15.97] 6.1	53.3 [15.62] 6.3	53.5 [15.68] 6.3	52.2 [15.29] 6.5	51.0 [14.94] 6.6	47.3 [13.86] 6.3	46.1 [13.51] 6.4	44.9 [13.16] 6.6
	20 [-6.7]	Total BTUH [kW] Power	61.3 [17.96] 6.0	60.1 [17.61] 6.2	58.9 [17.26] 6.4	59.0 [17.29] 6.4	57.8 [16.94] 6.6	56.6 [16.58] 6.7	52.8 [15.47] 6.4	51.6 [15.12] 6.5	50.4 [14.77] 6.7
	25 [-3.9]	Total BTUH [kW] Power	67.2 [19.69] 6.1	66.0 [19.34] 6.3	64.8 [18.99] 6.5	64.9 [19.02] 6.5	63.7 [18.66] 6.7	62.5 [18.31] 6.8	58.7 [17.20] 6.5	57.5 [16.85] 6.6	56.3 [16.50] 6.8
	30 [-1.1]	Total BTUH [kW] Power	73.0 [21.39] 6.2	71.8 [21.04] 6.4	70.6 [20.69] 6.6	70.7 [20.72] 6.6	69.5 [20.36] 6.8	68.3 [20.01] 6.9	64.6 [18.93] 6.6	63.4 [18.58] 6.7	62.1 [18.20] 6.9
	35 [1.7]	Total BTUH [kW] Power	78.5 [23.00] 6.3	77.3 [22.65] 6.5	76.1 [22.30] 6.7	76.3 [22.36] 6.7	75.0 [21.98] 6.9	73.8 [21.62] 7.0	70.1 [20.54] 6.7	68.9 [20.19] 6.8	67.7 [19.84] 7.0
	40 [4.4]	Total BTUH [kW] Power	83.4 [24.44] 6.4	82.2 [24.08] 6.6	81.0 [23.73] 6.8	81.1 [23.76] 6.8	79.9 [23.41] 7.0	78.7 [23.06] 7.1	74.9 [21.95] 6.8	73.7 [21.59] 6.9	72.5 [21.24] 7.1
	45 [7.2]	Total BTUH [kW] Power	87.2 [25.55] 6.5	86.0 [25.20] 6.7	84.8 [24.85] 6.9	85.0 [24.91] 6.9	83.7 [24.52] 7.1	82.5 [24.17] 7.2	78.8 [23.09] 6.9	77.6 [22.74] 7.0	76.4 [22.39] 7.2
50 [10]	Total BTUH [kW] Power	89.8 [26.31] 6.6	88.6 [25.96] 6.8	87.4 [25.61] 7.0	87.5 [25.64] 7.0	86.3 [25.29] 7.2	85.1 [24.93] 7.3	81.3 [23.82] 7.0	80.1 [23.47] 7.2	78.9 [23.12] 7.3	

IDB—Indoor air dry bulb

[] Designates Metric Conversions

COOLING PERFORMANCE DATA—RPWE-120/RHGG-120

ENTERING INDOOR AIR @ 80°F [26.7°C] dbE ①											
wbE		71°F [21.7°C]			67°F [19.4°C]			63°F [17.2°C]			
CFM [L/s]		4440 [2095]	3700 [1746]	2960 [1397]	4440 [2095]	3700 [1746]	2960 [1397]	4440 [2095]	3700 [1746]	2960 [1397]	
DR ①		.17			.14			.11			
OUTDOOR DRY BULB TEMPERATURE °F [°C]	75 [23.9]	Total BTUH [kW]	141.5 [99.15]	136.9 [40.12]	132.4 [38.80]	140.1 [41.06]	135.5 [39.71]	131.0 [38.39]	135.4 [39.68]	130.9 [38.36]	126.3 [37.01]
		Sens BTUH [kW]	84.7 [24.82]	76.3 [22.36]	67.9 [19.90]	103.3 [30.27]	94.9 [27.81]	86.5 [25.35]	117.8 [34.52]	109.4 [32.06]	101.0 [29.60]
		Power	9.3	9.1	8.9	9.0	8.8	8.7	8.6	8.4	8.3
	80 [26.7]	Total BTUH [kW]	139.3 [40.82]	134.8 [39.51]	130.3 [38.19]	137.9 [40.41]	133.4 [39.10]	128.8 [37.75]	133.2 [39.04]	128.7 [37.72]	124.2 [36.40]
		Sens BTUH [kW]	82.9 [24.30]	74.4 [21.80]	66.0 [19.34]	101.4 [29.72]	93.0 [27.26]	84.6 [24.79]	115.9 [33.97]	107.5 [31.51]	99.1 [29.04]
		Power	9.7	9.5	9.4	9.4	9.2	9.1	9.0	8.9	8.7
	85 [29.4]	Total BTUH [kW]	136.8 [40.09]	132.2 [38.74]	127.7 [37.43]	135.3 [39.65]	130.8 [38.33]	126.3 [37.01]	130.7 [38.30]	126.1 [36.96]	121.6 [35.64]
		Sens BTUH [kW]	81.6 [23.91]	73.2 [21.45]	64.8 [18.99]	100.2 [29.37]	91.8 [26.90]	83.3 [24.41]	114.7 [33.62]	106.3 [31.15]	97.9 [28.69]
		Power	10.1	9.9	9.8	9.8	9.7	9.5	9.5	9.3	9.1
	90 [32.2]	Total BTUH [kW]	133.8 [39.21]	129.3 [37.89]	124.8 [36.58]	132.4 [38.80]	127.9 [37.48]	123.3 [36.14]	127.7 [37.43]	123.2 [36.11]	118.7 [34.79]
	Sens BTUH [kW]	80.7 [23.65]	72.3 [21.19]	63.9 [18.73]	99.3 [29.10]	90.9 [26.64]	82.5 [24.18]	113.8 [33.35]	105.4 [30.89]	97.0 [28.43]	
	Power	10.5	10.4	10.2	10.3	10.1	9.9	9.9	9.7	9.5	
95 [35]	Total BTUH [kW]	130.6 [38.28]	126.1 [36.96]	121.6 [35.64]	129.2 [37.86]	124.7 [36.55]	120.2 [35.23]	124.6 [36.52]	120.0 [35.17]	115.5 [33.85]	
	Sens BTUH [kW]	80.0 [23.45]	71.6 [20.98]	63.2 [18.52]	98.6 [28.90]	90.2 [26.44]	81.8 [23.97]	113.1 [33.15]	104.7 [30.68]	96.3 [28.22]	
	Power	11.0	10.8	10.6	10.7	10.5	10.3	10.3	10.1	10.0	
100 [37.8]	Total BTUH [kW]	127.3 [37.31]	122.7 [35.96]	118.2 [34.64]	125.8 [36.87]	121.3 [35.55]	116.8 [34.23]	121.2 [35.52]	116.6 [34.17]	112.1 [32.85]	
	Sens BTUH [kW]	79.2 [23.21]	70.8 [20.75]	62.4 [18.29]	97.8 [28.66]	89.4 [26.20]	81.0 [23.74]	112.3 [32.91]	103.9 [30.45]	95.5 [27.99]	
	Power	11.4	11.2	11.0	11.1	10.9	10.8	10.7	10.5	10.4	
105 [40.6]	Total BTUH [kW]	123.8 [36.28]	119.2 [34.93]	114.7 [33.62]	122.4 [35.87]	117.8 [34.52]	113.3 [33.20]	117.7 [34.49]	113.2 [33.18]	108.6 [31.83]	
	Sens BTUH [kW]	78.1 [22.89]	69.7 [20.43]	61.3 [17.97]	96.7 [28.34]	88.3 [25.88]	79.8 [23.39]	111.2 [32.59]	102.8 [30.13]	94.4 [27.67]	
	Power	11.8	11.6	11.5	11.5	11.3	11.2	11.1	11.0	10.8	
110 [43.3]	Total BTUH [kW]	120.3 [35.26]	115.7 [33.91]	111.2 [32.59]	118.8 [34.82]	114.3 [33.50]	109.8 [32.18]	114.2 [33.47]	109.6 [32.12]	105.1 [30.80]	
	Sens BTUH [kW]	76.4 [22.39]	68.0 [19.93]	59.6 [17.47]	95.0 [27.84]	86.6 [25.38]	78.1 [22.89]	109.5 [32.09]	101.1 [29.63]	92.7 [27.17]	
	Power	12.2	12.0	11.9	11.9	11.8	11.6	11.6	11.4	11.2	
115 [46.1]	Total BTUH [kW]	116.8 [34.23]	112.3 [32.91]	107.7 [31.56]	115.4 [33.82]	110.9 [32.50]	106.3 [31.15]	110.7 [32.44]	106.2 [31.12]	101.7 [29.81]	
	Sens BTUH [kW]	73.9 [21.66]	65.5 [19.20]	57.1 [16.73]	92.5 [27.11]	84.1 [24.65]	75.6 [22.16]	107.0 [31.36]	98.6 [28.90]	90.2 [26.44]	
	Power	12.6	12.5	12.3	12.4	12.2	12.0	12.0	11.8	11.6	

DR —Depression ratio
 dbE —Entering air dry bulb
 wbE—Entering air wet bulb

Total —Total capacity x 1000 BTUH
 Sens —Sensible capacity x 1000 BTUH
 Power—KW input

NOTES:

① When the entering air dry bulb is other than 80°F [27°C], adjust the sensible capacity from the table by adding $[1.10 \times \text{CFM} \times (1 - \text{DR}) \times (\text{dbE} - 80)]$.

HEATING PERFORMANCE DATA—RPWE-120/RHGG-120

IDB		60°F [15.5°C]			70°F [21.1°C]			80°F [26.7°C]			
CFM [L/s]		4800 [2265]	4000 [1888]	3200 [1510]	4800 [2265]	4000 [1888]	3200 [1510]	4800 [2265]	4000 [1888]	3200 [1510]	
OUTDOOR DRY BULB TEMPERATURE °F [°C]	0 [-17.8]	Total BTUH [kW]	57.5 [16.85]	55.8 [16.35]	54.1 [15.86]	56.1 [16.44]	54.4 [15.94]	52.7 [15.44]	55.4 [16.24]	53.7 [15.74]	52.0 [15.24]
		Power	6.7	7.0	7.2	7.6	7.9	8.1	8.8	9.0	9.3
	5 [-15]	Total BTUH [kW]	71.5 [20.95]	69.8 [20.46]	68.1 [19.96]	70.1 [20.54]	68.4 [20.05]	66.7 [19.55]	69.4 [20.34]	67.7 [19.84]	66.0 [19.34]
		Power	7.0	7.2	7.5	7.9	8.1	8.4	9.0	9.2	9.5
	10 [-12.2]	Total BTUH [kW]	76.9 [22.54]	75.2 [22.04]	73.5 [21.54]	75.5 [22.13]	73.8 [21.63]	72.1 [21.13]	74.8 [21.92]	73.1 [21.42]	71.4 [20.93]
		Power	7.2	7.4	7.7	8.1	8.4	8.6	9.2	9.5	9.7
	15 [-9.4]	Total BTUH [kW]	76.5 [22.42]	74.8 [21.92]	73.1 [21.42]	75.1 [22.01]	73.4 [21.51]	71.7 [21.01]	74.3 [21.78]	72.6 [21.28]	70.9 [20.78]
		Power	7.4	7.7	7.9	8.3	8.6	8.8	9.5	9.7	10.0
	20 [-6.7]	Total BTUH [kW]	73.0 [21.39]	71.3 [20.90]	69.6 [20.40]	71.7 [21.01]	70.0 [20.51]	68.3 [20.02]	70.9 [20.78]	69.2 [20.28]	67.5 [19.78]
		Power	7.7	7.9	8.2	8.6	8.8	9.1	9.7	9.9	10.2
25 [-3.9]	Total BTUH [kW]	69.4 [20.34]	67.7 [19.84]	66.0 [19.34]	68.1 [19.96]	66.4 [19.46]	64.7 [18.96]	67.3 [19.72]	65.6 [19.23]	63.9 [18.73]	
	Power	7.9	8.1	8.4	8.8	9.1	9.3	9.9	10.2	10.4	
30 [-1.1]	Total BTUH [kW]	68.4 [20.05]	66.7 [19.55]	65.0 [19.05]	67.1 [19.67]	65.4 [19.17]	63.7 [18.67]	66.3 [19.43]	64.6 [18.93]	62.9 [18.43]	
	Power	8.1	8.4	8.6	9.0	9.3	9.5	10.2	10.4	10.7	
35 [1.7]	Total BTUH [kW]	72.8 [21.34]	71.1 [20.84]	69.4 [20.34]	71.5 [20.95]	69.8 [20.46]	68.1 [19.96]	70.7 [20.72]	69.0 [20.22]	67.3 [19.72]	
	Power	8.4	8.6	8.9	9.3	9.5	9.8	10.4	10.7	10.9	
40 [4.4]	Total BTUH [kW]	85.4 [25.03]	83.7 [24.53]	82.0 [24.03]	84.1 [24.65]	82.4 [24.15]	80.7 [23.65]	83.3 [24.41]	81.6 [23.91]	79.9 [23.42]	
	Power	8.6	8.9	9.1	9.5	9.8	10.0	10.6	10.9	11.1	
45 [7.2]	Total BTUH [kW]	109.0 [31.94]	107.3 [31.45]	105.6 [30.95]	107.7 [31.56]	106.0 [31.07]	104.3 [30.57]	106.9 [31.33]	105.2 [30.83]	103.5 [30.33]	
	Power	8.8	9.1	9.3	9.7	10.0	10.3	10.9	11.1	11.4	
50 [10]	Total BTUH [kW]	146.5 [42.93]	144.8 [42.44]	143.1 [41.94]	145.1 [42.52]	143.4 [42.03]	141.7 [41.53]	144.3 [42.29]	142.6 [41.79]	140.9 [41.29]	
	Power	9.1	9.3	9.6	10.0	10.2	10.5	11.1	11.4	11.6	

IDB—Indoor air dry bulb

[] Designates Metric Conversions

TYPICAL REFRIGERANT PIPING RECOMMENDATIONS

General Notes:

1. Vertical risers not to exceed 60 feet [18.29 m].
2. Locate the remote heat pump unit and indoor air handler as close together as possible to minimize piping runs.
3. Remote heat pump units are shipped with a nitrogen holding charge. Evacuate remote heat pump unit before charging with refrigerant.
4. Runs between remote heat pump and indoor air handler are not to exceed 90' [27.43 m] linear length.

EQUIVALENT LENGTH (FT.) [m] OF STRAIGHT TYPE "L" TUBING FOR NON-FERROUS VALVES AND FITTINGS (BRAZED)				
TUBE SIZE INCHES [mm] O.D.	ANGLE VALVE	SHORT RADIUS ELL	LONG RADIUS ELL	TEE LINE FLOW
1/2 [12.7]	24 [7.32]	4.7 [1.43]	3.2 [0.98]	1.7 [0.52]
5/8 [15.88]	25 [7.62]	5.7 [1.74]	3.9 [1.19]	2.3 [0.70]
3/4 [19.05]	25 [7.62]	6.5 [1.98]	4.5 [1.37]	2.9 [0.88]
7/8 [22.23]	28 [8.53]	7.8 [2.38]	5.3 [1.62]	3.7 [1.13]
1 1/8 [28.58]	29 [8.84]	2.7 [0.82]	1.9 [0.58]	5.2 [1.59]
1 3/8 [34.93]	33 [10.06]	3.2 [0.98]	2.2 [0.67]	6.9 [2.10]

RECOMMENDED VAPOR AND LIQUID LINE SIZES FOR VARIOUS LENGTHS OF RUN				
LINEAR LENGTH (FT.) [m]	LIQUID LINE O.D. SIZES (IN.) [mm]		VAPOR LINE O.D. SIZES (IN.) [mm]	
	090	120	090	120
0-40 [0-12.19]	1/2 [12.7]	5/8 [15.88]	1 1/8 [28.58]	1 3/8 [34.93]
41-90 [12.5-27.43]	1/2 [12.7]	5/8 [15.88]	1 3/8 [34.93]*	1 3/8 [34.93]*

*NOTE: With the outdoor unit located below the indoor air handler, all vertical vapor lines must not exceed 1 1/8" [28.58 mm] O.D.

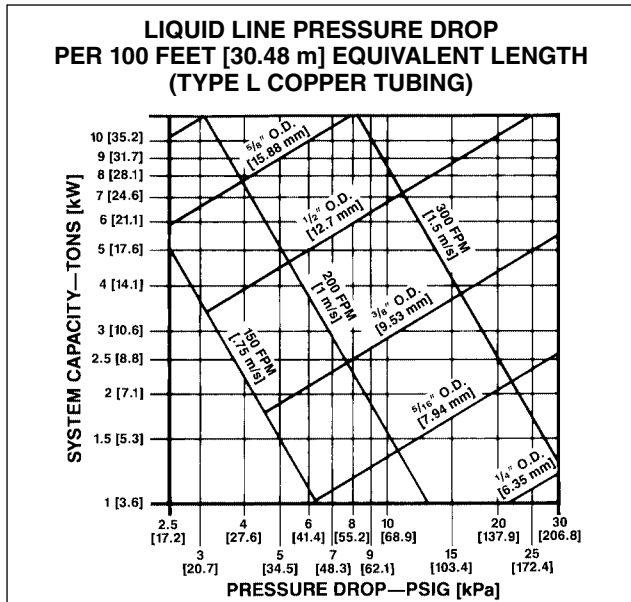

NOTES:

- 1) The pressure drop due to vertical lift (.5 PSIG per foot of lift) [22.62 kPa per meter] **must** be added to the pressure drop derived from this curve.
- 2) Size liquid line for **no more** than 10°F [-12.2°C] loss (approximately 30 PSIG [206.8 kPa] total pressure drop).
- 3) **Do not oversize liquid line.** Oversized liquid lines add significantly to the amount of refrigerant required to charge the system.

WARNING

Do not use oxygen to purge lines or pressure system for leak test. Oxygen reacts violently with oil, which can cause an explosion resulting in severe personal injury or death.

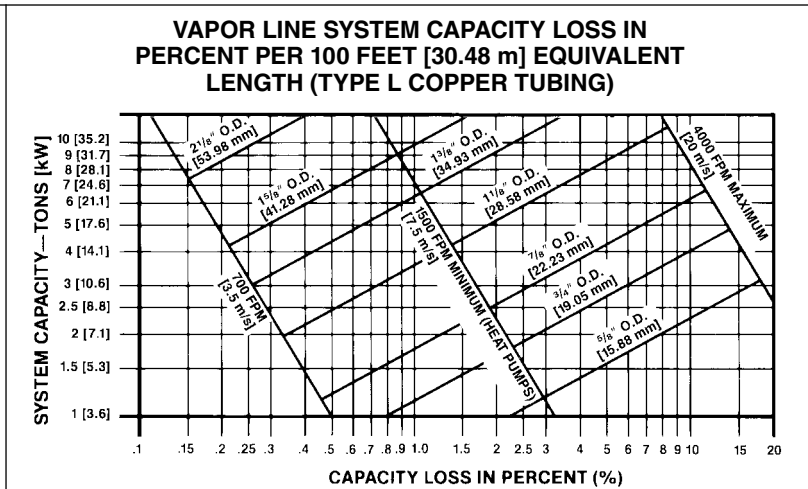

NOTES:

- 1) The minimum velocity line (1500 FPM) [7.5 m/s] is recommended.
- 2) With the outdoor unit located below the indoor air handler, all vertical vapor lines must not exceed 1 1/8" [28.58 mm] O.D.
- 3) For suction pressure drop (PSIG) [6.9 kPa], multiply percent (%) loss by 1.18.
- 4) Size vapor lines for no more than a 3 PSIG [20.7 kPa] pressure drop (2.54% capacity loss) which corresponds to approximately 2°F [-16.7°C] loss.
- 5) All vertical vapor lines, 3 feet [.91 m] or more in length, must have a short radius oil trap at the bottom of the riser.
- 6) All vertical vapor lines, 30 feet [9.14 m] or more in length, must have short radius oil traps every 15 to 20 feet [4.57 to 6.10 m] of run.

COIL ABOVE HEAT PUMP UNIT

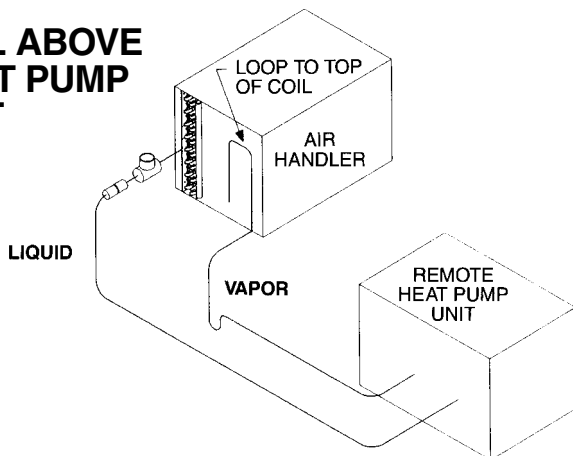

COIL BELOW HEAT PUMP UNIT

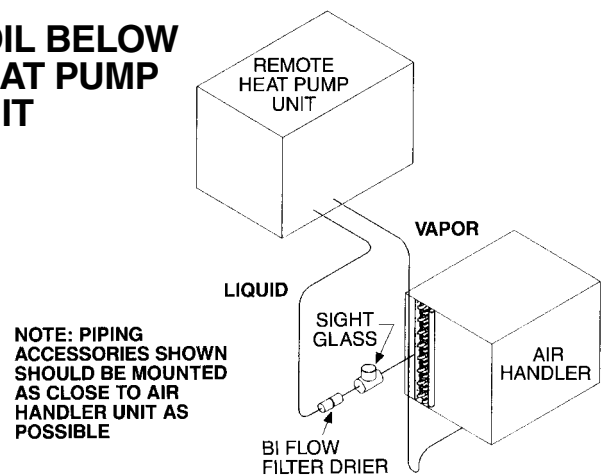

AIRFLOW CORRECTION FACTORS*

RPWE-090 with RHGG-120 @ 3200 CFM [1510 L/s]

ACTUAL—CFM [L/s]	2600 [1227]	2800 [1321]	3000 [1416]	3200 [1510]	3400 [1605]	3600 [1699]	3800 [1793]
TOTAL MBH	.97	.98	.99	1.00	1.01	1.02	1.03
SENSIBLE MBH	.91	.94	.97	1.00	1.03	1.06	1.09
POWER KW	.99	.99	1.00	1.00	1.00	1.01	1.01

RPWE-120 with RHGG-120 @ 3700 CFM [1746 L/s]

ACTUAL—CFM [L/s]	3100 [1463]	3300 [1557]	3500 [1588]	3700 [1746]	3900 [1841]	4100 [1935]	4300 [2029]	4400 [2077]
TOTAL MBH	.97	.98	.99	1.00	1.01	1.02	1.03	1.04
SENSIBLE MBH	.92	.95	.97	1.00	1.03	1.05	1.08	1.09
POWER KW	.98	.99	.99	1.00	1.01	1.01	1.02	1.02

*Airflow correction factor table for matched systems example (above) only.

GENERAL INSTALLATION

The Remote Heat Pump unit must be installed outdoors. It should be located as near as possible to the indoor section to keep connecting refrigerant tubing lengths to a minimum. The unit must be installed to allow a free air flow to the outdoor coils.

If several units are installed adjacent to each other, care must be taken to avoid recirculation of air from one remote heat pump to another. In all installations, adequate space must be provided for installation and servicing.

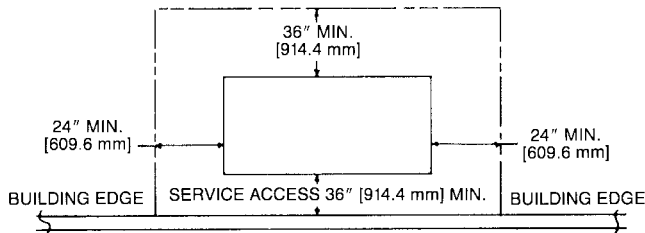

The outdoor unit must not be connected to any duct work. Do not locate unit under a roof drip; if necessary, install gutters, etc., to prevent water run-off from hitting the unit. To prevent air recirculation, it is recommended that the unit not be installed under an overhang, but if necessary **allow a minimum of 60 inches [1524 mm] above the unit for air discharge.**

[] Designates Metric Conversions

RIGGING

090 & 120 MODELS

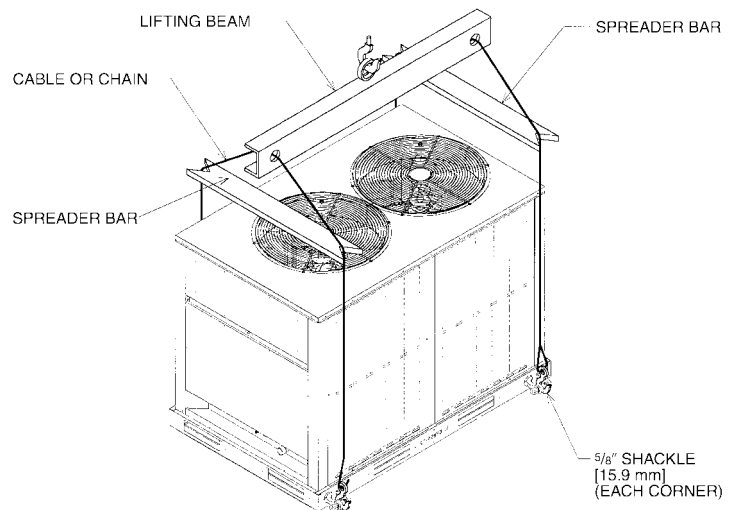

SLAB INSTALLATION

Remote Heat Pump units should be set on a solid level foundation. When installed at ground level, the unit should be placed on a 6 inch [152.4 mm] cement slab. If the pad is formed at the installation site, do not pour the pad tight against the structure, otherwise vibration will be transmitted from the unit through the pad.

ROOFTOP INSTALLATION

If rooftop installation is required, make certain that the building construction is adequate for the weight of the unit. (Refer to physical data chart.) Before placing the unit on the roof, make certain that the nylon rigging slings are of sufficient length to maintain equilibrium of the unit when lifting. Under no circumstances should the unit be lifted by only one corner for rooftop installation.

TYPICAL FIELD WIRING CONNECTIONS

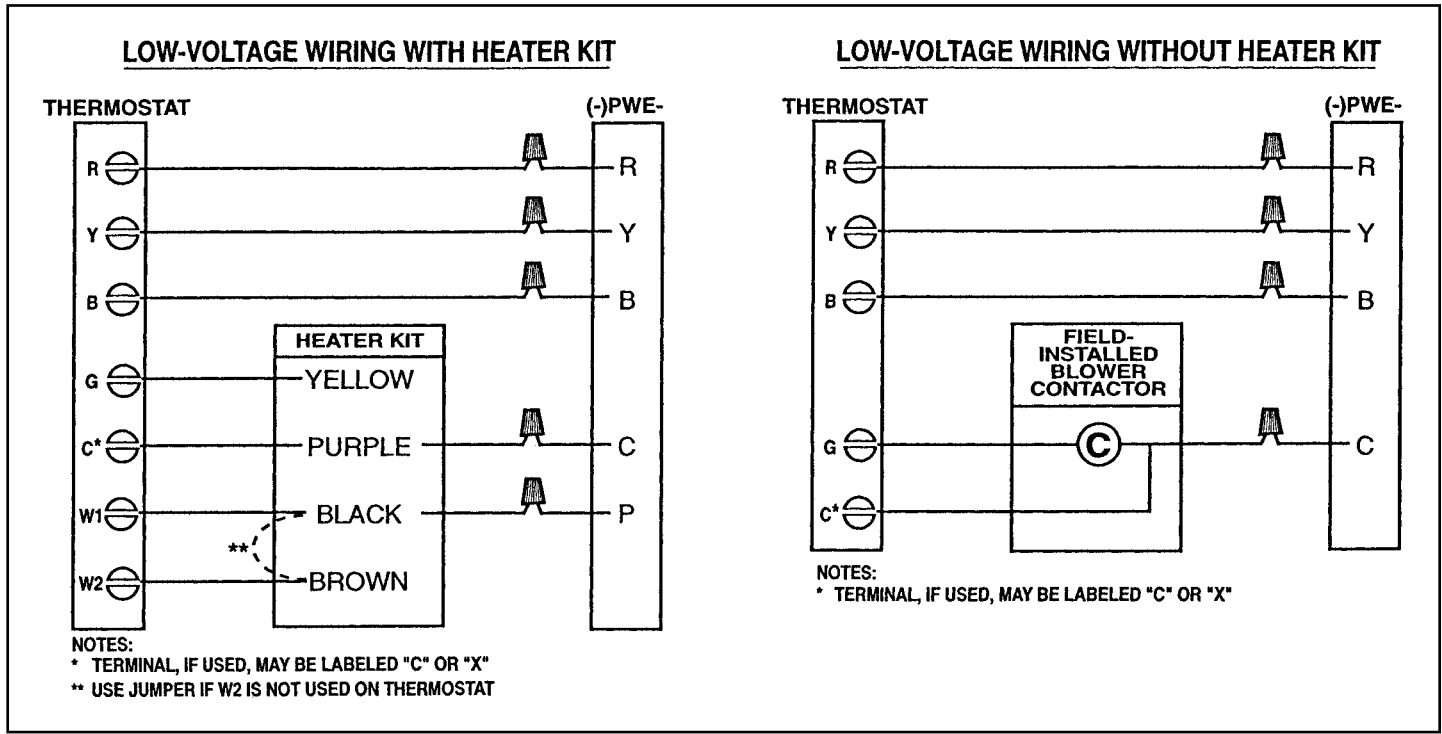

THERMOSTATS AND SUBBASES

The following thermostats and subbases are compatible with the basic models RPWE-090 and RPWE-120.

RHEEM PART NUMBER	MANUFACTURER	TYPE	STAGES
41-20804-15	General Electric	Mercury Bulb	2 Heat/1 Cool
41-23962-21	Robertshaw	Electronic Night Set-Back	2 Heat/2 Cool
41-21594-05	Honeywell	Electronic Night Set-Back	2 Heat/1 Cool

All the above thermostats are manual changeover with emergency heat over ride and indicator lamps.

SEQUENCE OF OPERATION

COOLING MODE

1. With thermostat in the cool mode, fan auto and the room temperature higher than the thermostat setting:
 - a. Indoor blower contactor (BC) is energized through thermostat contact (G) (See Indoor Air Handler).
 - b. Compressor contactor (CC) is energized through thermostat contact (Y) and safety controls.
 - c. Room thermostat locks out the defrost relay (DR), defrost control (DFC) and reversing valve (RV).
 - d. The system will continue in the cooling operation as long as all safety controls are closed until the thermostat is satisfied.
 1. The reversing valve remains in the cooling mode when the thermostat is satisfied.

HEATING MODE

1. With the thermostat in the heat mode, fan auto and the room temperature lower than the thermostat setting.
 - a. Indoor blower contactor (BC) is energized through thermostat contact (G) (See Indoor Air Handler).
 - b. Compressor contactor (CC) is energized through thermostat contact (Y) and safety controls.
 - c. Defrost control (DFC) energized.

1. Reversing valve (RV) and defrost control (DFC) are energized through room thermostat contact (B).
2. The defrost control (DFC) will energize the defrost relay (DR) on a demand basis as required.
- d. Should the heat requirement be more than the heat pump can supply, a portion of the electric heat accessory (if supplied) is energized through room thermostat contact (W2). (See electric heat kit accessory section.)
- e. The system will continue the heating operation as long as all safety controls are closed until the room thermostat is satisfied. The reversing valve remains in the heating mode when the thermostat is satisfied.
- f. The unit will function in a defrost mode, reversing the compressor cycle to cooling and energizing the electric heat kit (if supplied), as required through the defrost relay (DR).
- g. If the refrigerant system becomes inoperable during a need for heating, the room thermostat may be set to "emergency heat" which will energize the remaining portion of the electric heat kit (if supplied).

GUIDE SPECIFICATIONS

GENERAL—Units shall be assembled on heavy gauge steel full perimeter forkable baserails with lifting holes. Unit shall include a hermetic scroll compressor(s), plate fin condenser coil, fans and motors, controls and holding charge of nitrogen. Operating Range shall be between 115°F and 0°F in cooling as standard from factory. Units shall be UL 1995 listed and rated in accordance with ARI Standard 340.

CASING—Unit shall be constructed of 18 gauge zinc coated heavy gauge, galvanized steel. Units shall have stamped louver panels offering 100% protection of condenser coil guards. Exterior surfaces shall be cleaned, phosphatized and finished with a weather-resistant baked enamel finish. Units surface shall be tested 1000 hours in salt spray test. Units shall have removable end panels which allow access to all major components and controls.

REFRIGERATION SYSTEM—Single Compressor—Units shall have a single refrigeration circuit. Each refrigeration circuit has an integral subcooling circuit. A refrigeration filter drier, expansion valve and check valves shall be provided as standard. The units shall have a liquid line and suction gas line service valve with gauge port. (Suction gas line service valve optional). Units shall have one direct drive hermetic scroll compressor with centrifugal oil pump providing positive lubrication to moving parts. Motor shall be suction gas-cooled and shall have a voltage utilization range of plus or minus 10 percent of nameplate voltage. Crankcase heater, discharge line thermostat, internal temperature and current-sensitive motor overloads shall be included for maximum protection. Scroll type compressor shall provide inherently low vibration and noise by having no suction and discharge valves. External high and low pressure cutout devices shall be provided.

CONDENSER COIL—Coils shall be internally finned or smooth bore 3/8" copper tubes mechanically bonded to configured aluminum plate fin as standard. Coil shall be factory pressure and leak tested to 450 psig air pressure.

CONDENSER FAN AND MOTOR(S)—Direct-drive, statically and dynamically balanced propeller fan(s) with aluminum blades and electro-coated steel hubs shall be used in draw-through vertical discharge position. Permanently lubricated totally enclosed construction type motors shall be provided and shall have built in current and thermal overload protection. Motor(s) shall have either ball or sleeve bearing type.

CONTROLS—Heat pump units shall be completely factory wired with necessary controls and contactor pressure lugs or terminal block for power wiring. Control wiring shall be 24-volt control circuit which includes fusing and control transformer. Units shall provide external location for mounting a fused disconnect device.

DEFROST CONTROLS—Unit shall be equipped with Demand Defrost Control to defrost outdoor coil.

LOW AMBIENT OPERATION—Standard units shall start and operate to 0° F when matched with Rheem air handlers and coils. Standard head pressure control permits operation to 0° F.

ANTI-SHORT-CYCLE TIMER—Shall prevent rapid on-off compressor cycling in light load conditions by not allowing compressor to operate for 5-7 minutes upon shutdown. Shall consist of a solid state timing device, 24-volt, 60 cycle with either 5 or 7 minute fixed-off timing period.

GENERAL TERMS OF LIMITED WARRANTY*

Rheem will furnish a replacement for any part of this product which fails in normal use and services within the applicable periods stated here, in accordance with the terms of the limited warranty.

CompressorFive (5) Years
Any Other PartOne (1) Year

*For Complete Details of the Limited Warranty, Including Applicable Terms and Conditions, See Your Local Installer or Contact the Manufacturer for a Copy.

NOTES

Before proceeding with installation, refer to installation instructions packaged with each model, as well as complying with all Federal, State, Provincial, and Local codes, regulations, and practices.

**RHEEM
AIR CONDITIONING
DIVISION**

5600 Old Greenwood Road, Fort Smith, Arkansas 72908



"In keeping with its policy of continuous progress and product improvement, Rheem reserves the right to make changes without notice."