



PACKAGE GAS ELECTRIC UNITS

FORM NO. R11-839 REV. 7
Supersedes Form No. R11-839 Rev. 6

Featuring Earth-Friendly R-410A Refrigerant

R-410A

RRNL- 13-SEER SERIES NOMINAL SIZES 2-5 TONS [7.0-17.6 kW]

RRPL- 14-SEER SERIES NOMINAL SIZES 2-5 TONS [7.0-17.6 kW]

RRRL- 16-SEER SERIES NOMINAL SIZES 2-5 TONS [7.0-17.6 kW]



ENERGYGUIDE		
Seasonal Energy Efficiency Ratio (SEER)		
RRNL 13.0	RRPL 14.0	RRRL 16.0
32.6 — Uses least energy → 16.05		
Annual Fuel Utilization Efficiency - AFUE		
THIS MODEL		
80.0%		
MID	HIGH	
74%	82%	88% 97%



*"Proper sizing and installation of equipment is critical to achieve optimal performance.
Ask your Contractor for details or visit www.energystar.gov."*



Unit Features & Benefits	3-4
Model Identification Options	5-6
General Data	
RRNL- Series	7-15
RRPL- Series	16-23
RRRL- Series	24-27
General Data Notes.....	28
Performance Data	
RRNL- Series	29-31
RRPL- Series	32-34
RRRL- Series	35-36
Airflow Performance	
RRNL- Series	37-39
RRPL- Series	40-43
RRPL- Series	44-45
Electrical Data	
RRNL- Series	46-48
RRPL- Series	49-51
RRRL- Series	52
Dimensional Data	53-54
Typical Installations	55
Accessories	56-64
Wiring Diagram/Schematic	65-72
Limited Warranty	76



UNIT FEATURES & BENEFITS—RRNL-/RRPL-/RRRL-

These quality features are included in the Rheem® Gas Heat/Electric Cooling Package Unit

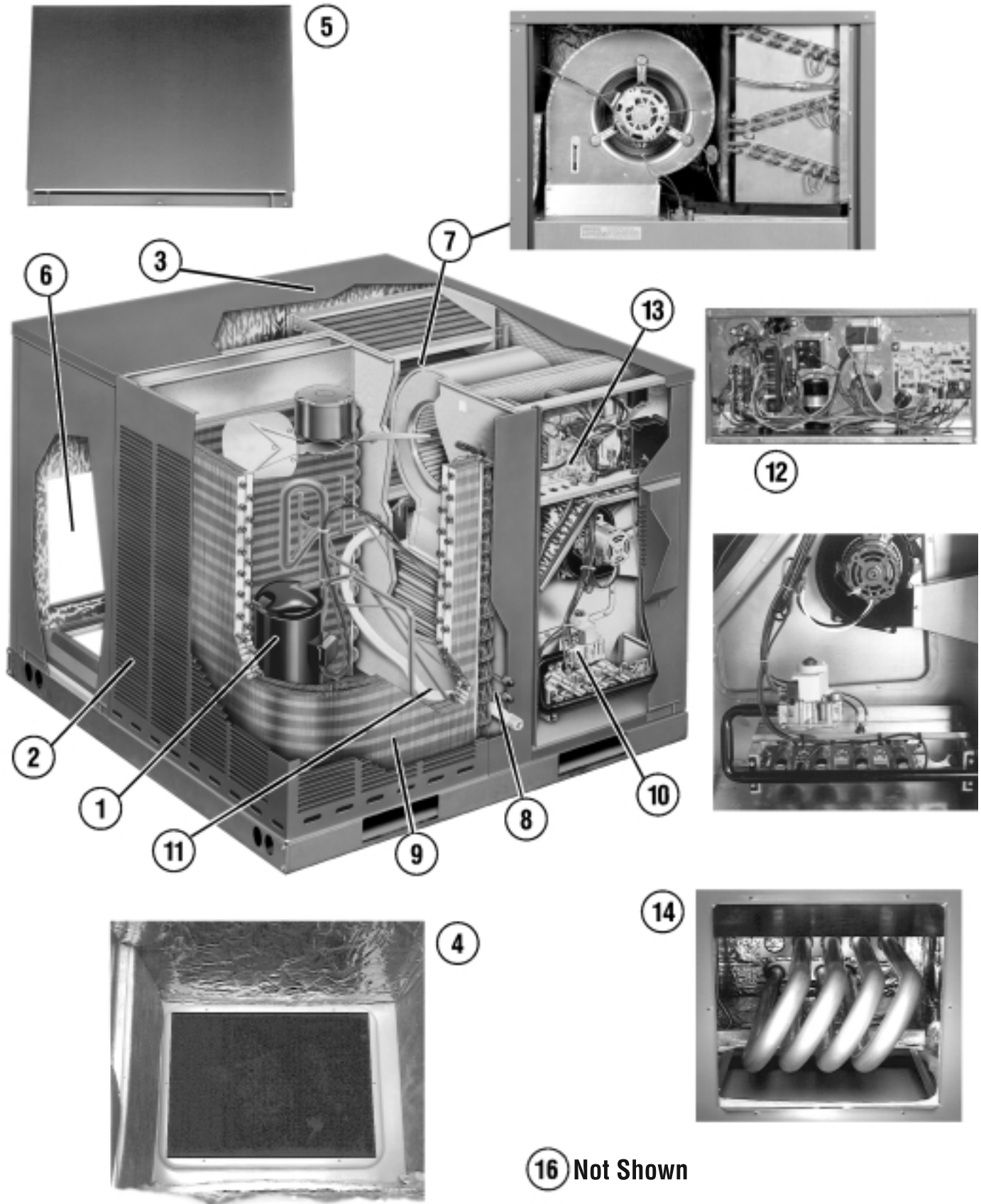



Features Below Correspond to Photos on Page 3

1. All models feature Scroll® compressors for maximum efficiency and quiet operation. 5 Ton RRPL and all RRRL models feature UltraTech™ Scroll 2-Stage compressors with Comfort Alert™ diagnostics (see below), high/low pressure switches, and hard start kits.
2. Louvered condenser compartment for protecting the coil against yard hazards and/or weather extremes.
3. One-piece top with a deep flange to help keep water out of the unit.
4. Supply and return air openings feature a one-inch tall flange to prevent water migration into the ductwork.
5. Access panels have “weep holes” and channels to further help manage water run-off.
6. Side and down discharge options available on all models. All models are shipped ready for horizontal application.
7. Easily accessible blower section complete with slide-out blower. The RRRL comes standard with variable speed motor with adjustable airflow in heating and cooling. The variable speed motor also comes with a interface that allows for dehumidification when used in continuous humidistat. The variable speed system is capable of 1 inch external static.
8. Refrigerant connections are conveniently located for easy service diagnostics.
9. Condenser and evaporator coils feature enhanced fins for better heat transfer and rifled copper tubing for greater efficiency.
10. Inside the easily accessible furnace compartment is the draft inducer motor. This motor is specially designed for quiet reliable operation. In addition to the draft inducer motor, the in-shot gas burners and manifold efficiently regulate the flow of gas for combustion. These new gas/electric units also feature direct-spark ignition and remote flame sensors for added reliability and efficiency.
11. All units feature an internal trap on the condensate line eliminating the need for installing an on-site external trap.
12. Easily accessible control box.
13. Single point wiring simplifies installation.
14. Our gas/electric package units feature a tubular heat exchanger design. Tubular heat exchangers are more efficient and durable than older-style clamshell heat exchangers. The heat exchanger is backed by a 10 year limited warranty. Models with a stainless steel heat exchanger installed in a residential application are backed by a limited lifetime warranty. The stainless steel heat exchanger is a standard feature on RRRL. Two stage gas heat is standard on the RRRL models.
15. Thermal expansion valve standard on all models for superior superheat control, reliability, and energy efficiency at all operating conditions.
16. Filter drier standard on all models (not shown).
17. Rugged baserail included for improved installation and handling
18. Complete factory charged, wired and run tested.
19. Molded compressor plugs.

Comfort Alert™ Diagnostics – Faster Service And Improved Accuracy (2-Stage Models Only)

The Comfort Alert™ diagnostics module is a breakthrough innovation for troubleshooting air conditioning system failures. The module is installed in the control box near the compressor contactor. By monitoring and analyzing data from the Scroll® compressor and the thermostat demand, the module can accurately detect the cause of electrical and system related failures without any sensors. A flashing LED indicator communicates the ALERT code and guides the service technician more quickly and accurately to the root cause of a problem.

NOTE: Single phase module does not provide safety protection! The Comfort Alert module is a monitoring device and cannot control or shut down the compressor unless used with a White Rodgers IF95-CA397 Thermostat.

NOTE: Three phase module provides compressor protection and will shut down the compressor when compressor damaging conditions are detected.

RRRL Models Also Feature:

- On Demand Dehumidification
- ECM motor with adjustable airflow in both heating and cooling to 1.0" SP static capability
- Stainless steel heat exchanger as standard
- Two stage gas heat



MODEL IDENTIFICATION—RRNL-/RRPL-/RRRL- SERIES



R R N L — B 036 J K 10 E X X X

Factory Installed Options
(See Next Page)

Ignition System
E = Electric
X = Electric No_x

Heating Capacity (MBH)
04 = 40,000 [11.7]
06 = 60,000 [17.6]
08 = 80,000 [23.4]
10 = 100,000 [29.3]

Drive Package
K = Direct Drive

Electrical Designation
J = 208-230V—1PH—60 Hz
C = 208-230V—3PH—60 Hz
D = 460V—3PH—60 Hz (RRNL- Only)

Cooling Capacity (BTUH) [kW]
024 = 24,000 [7.03]
030 = 30,000 [8.79]
036 = 36,000 [10.55]
042 = 42,000 [12.31]
048 = 48,000 [14.07]
060 = 60,000 [17.58]

Future Technical Variations
B = 1st Variation
C = 2nd Variation — 2 Stage Gas Heat

Design Series (R-410A)

Efficiency Designation
N = 13 SEER
P = 14 SEER
R = Up to 16 SEER

Product Classification
R = Rooftop

Tradebrand
R = Rheem

[] Designates Metric Conversions



Instructions for Factory Installed Option(s) Selection

Note: Three characters following the model number will be utilized to designate a factory-installed option or combination of options. If no factory option(s) is required, nothing follows the model number.

Step 1. After a basic rooftop model is selected, choose a *three-character* option code from the FACTORY INSTALLED OPTION SELECTION TABLE.

FACTORY INSTALLED OPTION CODES

Option Code	Stainless Steel Heat Exchanger	Side Flow
AJA	x	

“x” indicates factory installed option.

Example: No Option

RRNL-036JK08E

Example: Option with Stainless Steel Heat Exchanger

RRNL-036JK08EAJA

Note: Factory installed economizer is not available on these models.

*RRRL models are only available with BVA option.



NOMINAL SIZES 2-5 TONS [7.0-17.6 kW]

Model RRNL- Series	B024JK04(E/X)	B024JK06(E/X)	B024JK08(E/X)	B030JK04(E/X)
Cooling Performance¹				CONTINUED →
Gross Cooling Capacity Btu [kW]	24,400 [7.15]	24,400 [7.15]	24,400 [7.15]	29,800 [8.73]
EER/SEER ²	11.1/13	11.1/13	11.1/13	11.1/13
Nominal CFM/AHRI Rated CFM [L/s]	787/800 [371/378]	787/800 [371/378]	787/800 [371/378]	953/1000 [450/472]
AHRI Net Cooling Capacity Btu [kW]	23,600 [6.91]	23,600 [6.91]	23,600 [6.91]	28,600 [8.38]
Net Sensible Capacity Btu [kW]	17,340 [5.08]	17,340 [5.08]	17,340 [5.08]	20,810 [6.1]
Net Latent Capacity Btu [kW]	6,260 [1.83]	6,260 [1.83]	6,260 [1.83]	7,790 [2.28]
Net System Power [kW]	2.12	2.12	2.12	2.58
Heating Performance (Package Gas/Electric)³				
Heating Input Btu [kW]	40,000 [11.72]	60,000 [17.58]	80,000 [23.44]	40,000 [11.72]
Heating Output Btu [kW]	31,000 [9.08]	47,000 [13.77]	62,000 [18.17]	31,000 [9.08]
Temperature Rise Range °F [°C]	30-60 [16.7/33.3]	40-70 [22.2/38.9]	55-85 [30.6/47.2]	20-50 [11.1/27.8]
AFUE (%) ⁴	80	80	80	80
Steady State Efficiency (%)	81	81	81	81
No. Burners	2	3	4	2
No. Stages	1	1	1	1
Gas Connection Pipe Size in. [mm]	0.5 [12.7]	0.5 [12.7]	0.5 [12.7]	0.5 [12.7]
Compressor				
No./Type	1/Scroll	1/Scroll	1/Scroll	1/Scroll
Outdoor Sound Rating (dB)⁵	76	76	76	76
Outdoor Coil—Fin Type	Louvered	Louvered	Louvered	Louvered
Tube Type	Rifled	Rifled	Rifled	Rifled
Tube Size in. [mm] OD	0.375 [9.5]	0.375 [9.5]	0.375 [9.5]	0.375 [9.5]
Face Area sq. ft. [sq. m]	10.56 [0.98]	10.56 [0.98]	10.56 [0.98]	10.56 [0.98]
Rows / FPI [FPcm]	1 / 18 [7]	1 / 18 [7]	1 / 18 [7]	1 / 18 [7]
Indoor Coil—Fin Type	Louvered	Louvered	Louvered	Louvered
Tube Type	Rifled	Rifled	Rifled	Rifled
Tube Size in. [mm]	0.375 [9.5]	0.375 [9.5]	0.375 [9.5]	0.375 [9.5]
Face Area sq. ft. [sq. m]	5.54 [0.51]	5.54 [0.51]	5.54 [0.51]	5.54 [0.51]
Rows / FPI [FPcm]	2 / 15 [6]	2 / 15 [6]	2 / 15 [6]	2 / 15 [6]
Refrigerant Control	TX Valves	TX Valves	TX Valves	TX Valves
Drain Connection No./Size in. [mm]	1/0.75 [19.05]	1/0.75 [19.05]	1/0.75 [19.05]	1/0.75 [19.05]
Outdoor Fan—Type	Propeller	Propeller	Propeller	Propeller
No. Used/Diameter in. [mm]	1/22 [558.8]	1/22 [558.8]	1/22 [558.8]	1/22 [558.8]
Drive Type/No. Speeds	Direct/1	Direct/1	Direct/1	Direct/1
CFM [L/s]	2500 [1180]	2500 [1180]	2500 [1180]	2500 [1180]
No. Motors/HP	1 at 1/3 HP	1 at 1/3 HP	1 at 1/3 HP	1 at 1/3 HP
Motor RPM	1075	1075	1075	1075
Indoor Fan—Type	FC Centrifugal	FC Centrifugal	FC Centrifugal	FC Centrifugal
No. Used/Diameter in. [mm]	1/9x7 [229x178]	1/9x7 [229x178]	1/9x7 [229x178]	1/10x9 [254x229]
Drive Type/No. Speeds	Direct/2	Direct/2	Direct/2	Direct/3
No. Motors	1	1	1	1
Motor HP	1/4	1/4	1/4	1/2
Motor RPM	1075	1075	1075	1075
Motor Frame Size	48	48	48	48
Filter—Type	Field Supplied	Field Supplied	Field Supplied	Field Supplied
Furnished	No	No	No	No
(No.) Size Recommended in. [mm]	(1)1x20x20 [25x508x508]	(1)1x20x20 [25x508x508]	(1)1x20x20 [25x508x508]	(1)1x24x24 [25x610x610]
Refrigerant Charge Oz. [g]	77.8 [2206]	77.8 [2206]	77.8 [2206]	76.8 [2177]
Weights				
Net Weight lbs. [kg]	381 [173]	385 [175]	390 [177]	399 [181]
Ship Weight lbs. [kg]	421 [191]	425 [193]	430 [195]	439 [199]

See Page 28 for Notes.

[] Designates Metric Conversions



NOMINAL SIZES 2-5 TONS [7.0-17.6 kW]

Model RRNL- Series	B030JK06(E/X)	B030JK08(E/X)	B030JK10(E/X)	B036CK04
Cooling Performance¹				CONTINUED →
Gross Cooling Capacity Btu [kW]	29,800 [8.73]	29,800 [8.73]	29,800 [8.73]	37,000 [10.84]
EER/SEER ²	11.1/13	11.1/13	11.1/13	11.3/13
Nominal CFM/AHRI Rated CFM [L/s]	953/1000 [450/472]	953/1000 [450/472]	953/1000 [450/472]	1187/1200 [560/566]
AHRI Net Cooling Capacity Btu [kW]	28,600 [8.38]	28,600 [8.38]	28,600 [8.38]	35,600 [10.43]
Net Sensible Capacity Btu [kW]	20,810 [6.1]	20,810 [6.1]	20,810 [6.1]	26,390 [7.73]
Net Latent Capacity Btu [kW]	7,790 [2.28]	7,790 [2.28]	7,790 [2.28]	9,210 [2.7]
Net System Power [kW]	2.58	2.58	2.58	3.15
Heating Performance (Package Gas/Electric)³				
Heating Input Btu [kW]	60,000 [17.58]	80,000 [23.44]	100,000 [29.3]	40,000 [11.72]
Heating Output Btu [kW]	47,000 [13.77]	62,000 [18.17]	77,000 [22.56]	32,400 [9.49]
Temperature Rise Range °F [°C]	30-60 [16.7/33.3]	40-70 [22.2/38.9]	45-85 [25/47.2]	20-50 [11.1/27.8]
AFUE (%) ⁴	80	80	80	80
Steady State Efficiency (%)	81	81	81	81
No. Burners	3	4	5	2
No. Stages	1	1	1	1
Gas Connection Pipe Size in. [mm]	0.5 [12.7]	0.5 [12.7]	0.5 [12.7]	0.5 [12.7]
Compressor				
No./Type	1/Scroll	1/Scroll	1/Scroll	1/Scroll
Outdoor Sound Rating (dB)⁵	76	76	76	76
Outdoor Coil—Fin Type	Louvered	Louvered	Louvered	Louvered
Tube Type	Rifled	Rifled	Rifled	Rifled
Tube Size in. [mm] OD	0.375 [9.5]	0.375 [9.5]	0.375 [9.5]	0.375 [9.5]
Face Area sq. ft. [sq. m]	10.56 [0.98]	10.56 [0.98]	10.56 [0.98]	14.8 [1.37]
Rows / FPI [FPcm]	1 / 18 [7]	1 / 18 [7]	1 / 18 [7]	1 / 22 [9]
Indoor Coil—Fin Type	Louvered	Louvered	Louvered	Louvered
Tube Type	Rifled	Rifled	Rifled	Rifled
Tube Size in. [mm]	0.375 [9.5]	0.375 [9.5]	0.375 [9.5]	0.375 [9.5]
Face Area sq. ft. [sq. m]	5.54 [0.51]	5.54 [0.51]	5.54 [0.51]	5.54 [0.51]
Rows / FPI [FPcm]	2 / 15 [6]	2 / 15 [6]	2 / 15 [6]	2 / 15 [6]
Refrigerant Control	TX Valves	TX Valves	TX Valves	TX Valves
Drain Connection No./Size in. [mm]	1/0.75 [19.05]	1/0.75 [19.05]	1/0.75 [19.05]	1/0.75 [19.05]
Outdoor Fan—Type	Propeller	Propeller	Propeller	Propeller
No. Used/Diameter in. [mm]	1/22 [558.8]	1/22 [558.8]	1/22 [558.8]	1/22 [558.8]
Drive Type/No. Speeds	Direct/1	Direct/1	Direct/1	Direct/1
CFM [L/s]	2500 [1180]	2500 [1180]	2500 [1180]	2700 [1274]
No. Motors/HP	1 at 1/3 HP	1 at 1/3 HP	1 at 1/3 HP	1 at 1/3 HP
Motor RPM	1075	1075	1075	1075
Indoor Fan—Type	FC Centrifugal	FC Centrifugal	FC Centrifugal	FC Centrifugal
No. Used/Diameter in. [mm]	1/10x9 [254x229]	1/10x9 [254x229]	1/10x9 [254x229]	1/10x9 [254x229]
Drive Type/No. Speeds	Direct/3	Direct/3	Direct/3	Direct/3
No. Motors	1	1	1	1
Motor HP	1/2	1/2	1/2	1/2
Motor RPM	1075	1075	1075	1075
Motor Frame Size	48	48	48	48
Filter—Type	Field Supplied	Field Supplied	Field Supplied	Field Supplied
Furnished	No	No	No	No
(No.) Size Recommended in. [mm]	(1)1x24x24 [25x610x610]	(1)1x24x24 [25x610x610]	(1)1x24x24 [25x610x610]	(1)1x24x24 [25x610x610]
Refrigerant Charge Oz. [g]	76.8 [2177]	76.8 [2177]	76.8 [2177]	92.8 [2631]
Weights				
Net Weight lbs. [kg]	404 [183]	409 [186]	414 [188]	412 [187]
Ship Weight lbs. [kg]	444 [201]	449 [204]	454 [206]	452 [205]

See Page 28 for Notes.

[] Designates Metric Conversions



NOMINAL SIZES 2-5 TONS [7.0-17.6 kW]

Model RRNL- Series	B036CK06	B036CK08	B036CK10	B036DK06
Cooling Performance¹				CONTINUED →
Gross Cooling Capacity Btu [kW]	37,000 [10.84]	37,000 [10.84]	37,000 [10.84]	37,000 [10.84]
EER/SEER ²	11.3/13	11.3/13	11.3/13	11.3/13
Nominal CFM/AHRI Rated CFM [L/s]	1187/1200 [560/566]	1187/1200 [560/566]	1187/1200 [560/566]	1187/1200 [560/566]
AHRI Net Cooling Capacity Btu [kW]	35,600 [10.43]	35,600 [10.43]	35,600 [10.43]	35,600 [10.43]
Net Sensible Capacity Btu [kW]	26,390 [7.73]	26,390 [7.73]	26,390 [7.73]	26,390 [7.73]
Net Latent Capacity Btu [kW]	9,210 [2.7]	9,210 [2.7]	9,210 [2.7]	9,210 [2.7]
Net System Power [kW]	3.15	3.15	3.15	3.15
Heating Performance (Package Gas/Electric)³				
Heating Input Btu [kW]	60,000 [17.58]	80,000 [23.44]	100,000 [29.3]	60,000 [17.58]
Heating Output Btu [kW]	48,600 [14.24]	64,800 [18.99]	81,000 [23.73]	48,600 [14.24]
Temperature Rise Range °F [°C]	30-60 [16.7/33.3]	40-70 [22.2/38.9]	45-85 [25/47.2]	30-60 [16.7/33.3]
AFUE (%) ⁴	80	80	80	80
Steady State Efficiency (%)	81	81	81	81
No. Burners	3	4	5	3
No. Stages	1	1	1	1
Gas Connection Pipe Size in. [mm]	0.5 [12.7]	0.5 [12.7]	0.5 [12.7]	0.5 [12.7]
Compressor				
No./Type	1/Scroll	1/Scroll	1/Scroll	1/Scroll
Outdoor Sound Rating (dB)⁵	76	76	76	76
Outdoor Coil—Fin Type	Louvered	Louvered	Louvered	Louvered
Tube Type	Rifled	Rifled	Rifled	Rifled
Tube Size in. [mm] OD	0.375 [9.5]	0.375 [9.5]	0.375 [9.5]	0.375 [9.5]
Face Area sq. ft. [sq. m]	14.8 [1.37]	14.8 [1.37]	14.8 [1.37]	14.8 [1.37]
Rows / FPI [FPcm]	1 / 22 [9]	1 / 22 [9]	1 / 22 [9]	1 / 22 [9]
Indoor Coil—Fin Type	Louvered	Louvered	Louvered	Louvered
Tube Type	Rifled	Rifled	Rifled	Rifled
Tube Size in. [mm]	0.375 [9.5]	0.375 [9.5]	0.375 [9.5]	0.375 [9.5]
Face Area sq. ft. [sq. m]	5.54 [0.51]	5.54 [0.51]	5.54 [0.51]	5.54 [0.51]
Rows / FPI [FPcm]	2 / 15 [6]	2 / 15 [6]	2 / 15 [6]	2 / 15 [6]
Refrigerant Control	TX Valves	TX Valves	TX Valves	TX Valves
Drain Connection No./Size in. [mm]	1/0.75 [19.05]	1/0.75 [19.05]	1/0.75 [19.05]	1/0.75 [19.05]
Outdoor Fan—Type	Propeller	Propeller	Propeller	Propeller
No. Used/Diameter in. [mm]	1/22 [558.8]	1/22 [558.8]	1/22 [558.8]	1/22 [558.8]
Drive Type/No. Speeds	Direct/1	Direct/1	Direct/1	Direct/1
CFM [L/s]	2700 [1274]	2700 [1274]	2700 [1274]	2700 [1274]
No. Motors/HP	1 at 1/3 HP	1 at 1/3 HP	1 at 1/3 HP	1 at 1/3 HP
Motor RPM	1075	1075	1075	1075
Indoor Fan—Type	FC Centrifugal	FC Centrifugal	FC Centrifugal	FC Centrifugal
No. Used/Diameter in. [mm]	1/10x9 [254x229]	1/10x9 [254x229]	1/10x9 [254x229]	1/10x9 [254x229]
Drive Type/No. Speeds	Direct/3	Direct/3	Direct/3	Direct/2
No. Motors	1	1	1	1
Motor HP	1/2	1/2	1/2	1/2
Motor RPM	1075	1075	1075	1075
Motor Frame Size	48	48	48	48
Filter—Type	Field Supplied	Field Supplied	Field Supplied	Field Supplied
Furnished	No	No	No	No
(No.) Size Recommended in. [mm]	(1)1x24x24 [25x610x610]	(1)1x24x24 [25x610x610]	(1)1x24x24 [25x610x610]	(1)1x24x24 [25x610x610]
Refrigerant Charge Oz. [g]	92.8 [2631]	92.8 [2631]	92.8 [2631]	92.8 [2631]
Weights				
Net Weight lbs. [kg]	417 [189]	422 [191]	426 [193]	417 [189]
Ship Weight lbs. [kg]	457 [207]	462 [210]	466 [211]	457 [207]

See Page 28 for Notes.

[] Designates Metric Conversions



NOMINAL SIZES 2-5 TONS [7.0-17.6 kW]

Model RRNL- Series	B036DK08	B036DK10	B036JK04(E/X)	B036JK06(E/X)
Cooling Performance¹				CONTINUED →
Gross Cooling Capacity Btu [kW]	37,000 [10.84]	37,000 [10.84]	37,000 [10.84]	37,000 [10.84]
EER/SEER ²	11.3/13	11.3/13	11.3/13	11.3/13
Nominal CFM/AHRI Rated CFM [L/s]	1187/1200 [560/566]	1187/1200 [560/566]	1187/1200 [560/566]	1187/1200 [560/566]
AHRI Net Cooling Capacity Btu [kW]	35,600 [10.43]	35,600 [10.43]	35,600 [10.43]	35,600 [10.43]
Net Sensible Capacity Btu [kW]	26,390 [7.73]	26,390 [7.73]	26,390 [7.73]	26,390 [7.73]
Net Latent Capacity Btu [kW]	9,210 [2.7]	9,210 [2.7]	9,210 [2.7]	9,210 [2.7]
Net System Power [kW]	3.15	3.15	3.15	3.15
Heating Performance (Gas)³				
Heating Input Btu [kW]	80,000 [23.44]	100,000 [29.3]	40,000 [11.72]	60,000 [17.58]
Heating Output Btu [kW]	64,800 [18.99]	81,000 [23.73]	31,000 [9.08]	47,000 [13.77]
Temperature Rise Range °F [°C]	40-70 [22.2/38.9]	45-85 [25/47.2]	20-50 [11.1/27.8]	30-60 [16.7/33.3]
AFUE (%) ⁴	80	80	80	80
Steady State Efficiency (%)	81	81	81	81
No. Burners	4	5	2	3
No. Stages	1	1	1	1
Gas Connection Pipe Size in. [mm]	0.5 [12.7]	0.5 [12.7]	0.5 [12.7]	0.5 [12.7]
Compressor				
No./Type	1/Scroll	1/Scroll	1/Scroll	1/Scroll
Outdoor Sound Rating (dB)⁵	76	76	76	76
Outdoor Coil—Fin Type	Louvered	Louvered	Louvered	Louvered
Tube Type	Rifled	Rifled	Rifled	Rifled
Tube Size in. [mm] OD	0.375 [9.5]	0.375 [9.5]	0.375 [9.5]	0.375 [9.5]
Face Area sq. ft. [sq. m]	14.8 [1.37]	14.8 [1.37]	14.8 [1.37]	14.8 [1.37]
Rows / FPI [FPcm]	1 / 22 [9]	1 / 22 [9]	1 / 22 [9]	1 / 22 [9]
Indoor Coil—Fin Type	Louvered	Louvered	Louvered	Louvered
Tube Type	Rifled	Rifled	Rifled	Rifled
Tube Size in. [mm]	0.375 [9.5]	0.375 [9.5]	0.375 [9.5]	0.375 [9.5]
Face Area sq. ft. [sq. m]	5.54 [0.51]	5.54 [0.51]	5.54 [0.51]	5.54 [0.51]
Rows / FPI [FPcm]	2 / 15 [6]	2 / 15 [6]	2 / 15 [6]	2 / 15 [6]
Refrigerant Control	TX Valves	TX Valves	TX Valves	TX Valves
Drain Connection No./Size in. [mm]	1/0.75 [19.05]	1/0.75 [19.05]	1/0.75 [19.05]	1/0.75 [19.05]
Outdoor Fan—Type	Propeller	Propeller	Propeller	Propeller
No. Used/Diameter in. [mm]	1/22 [558.8]	1/22 [558.8]	1/22 [558.8]	1/22 [558.8]
Drive Type/No. Speeds	Direct/1	Direct/1	Direct/1	Direct/1
CFM [L/s]	2700 [1274]	2700 [1274]	2700 [1274]	2700 [1274]
No. Motors/HP	1 at 1/3 HP	1 at 1/3 HP	1 at 1/3 HP	1 at 1/3 HP
Motor RPM	1075	1075	1075	1075
Indoor Fan—Type	FC Centrifugal	FC Centrifugal	FC Centrifugal	FC Centrifugal
No. Used/Diameter in. [mm]	1/10x9 [254x229]	1/10x9 [254x229]	1/10x9 [254x229]	1/10x9 [254x229]
Drive Type/No. Speeds	Direct/2	Direct/2	Direct/3	Direct/3
No. Motors	1	1	1	1
Motor HP	1/2	1/2	1/2	1/2
Motor RPM	1075	1075	1075	1075
Motor Frame Size	48	48	48	48
Filter—Type	Field Supplied	Field Supplied	Field Supplied	Field Supplied
Furnished	No	No	No	No
(No.) Size Recommended in. [mm]	(1)1x24x24 [25x610x610]	(1)1x24x24 [25x610x610]	(1)1x24x24 [25x610x610]	(1)1x24x24 [25x610x610]
Refrigerant Charge Oz. [g]	92.8 [2631]	92.8 [2631]	92.8 [2631]	92.8 [2631]
Weights				
Net Weight lbs. [kg]	422 [191]	426 [193]	412 [187]	417 [189]
Ship Weight lbs. [kg]	462 [210]	466 [211]	452 [205]	457 [207]

See Page 28 for Notes.

[] Designates Metric Conversions



NOMINAL SIZES 2-5 TONS [7.0-17.6 kW]

Model RRNL- Series	B036JK08(E/X)	B036JK10(E/X)	B042CK04	B042CK06
Cooling Performance¹				CONTINUED →
Gross Cooling Capacity Btu [kW]	37,000 [10.84]	37,000 [10.84]	44,000 [12.89]	44,000 [12.89]
EER/SEER ²	11.3/13	11.3/13	11.2/13	11.2/13
Nominal CFM/AHRI Rated CFM [L/s]	1187/1200 [560/566]	1187/1200 [560/566]	1400/1400 [661/661]	1400/1400 [661/661]
AHRI Net Cooling Capacity Btu [kW]	35,600 [10.43]	35,600 [10.43]	42,000 [12.31]	42,000 [12.31]
Net Sensible Capacity Btu [kW]	26,390 [7.73]	26,390 [7.73]	30,510 [8.94]	30,510 [8.94]
Net Latent Capacity Btu [kW]	9,210 [2.7]	9,210 [2.7]	11,490 [3.37]	11,490 [3.37]
Net System Power [kW]	3.15	3.15	3.73	3.73
Heating Performance (Package Gas/Electric)³				
Heating Input Btu [kW]	80,000 [23.44]	100,000 [29.3]	40,000 [11.72]	60,000 [17.58]
Heating Output Btu [kW]	62,000 [18.17]	77,000 [22.56]	32,400 [9.49]	48,600 [14.24]
Temperature Rise Range °F [°C]	40-70 [22.2/38.9]	45-85 [25/47.2]	20-50 [11.1/27.8]	30-60 [16.7/33.3]
AFUE (%) ⁴	80	80	80	80
Steady State Efficiency (%)	81	81	81	81
No. Burners	4	5	2	3
No. Stages	1	1	1	1
Gas Connection Pipe Size in. [mm]	0.5 [12.7]	0.5 [12.7]	0.5 [12.7]	0.5 [12.7]
Compressor				
No./Type	1/Scroll	1/Scroll	1/Scroll	1/Scroll
Outdoor Sound Rating (dB)⁵	76	76	76	76
Outdoor Coil—Fin Type	Louvered	Louvered	Louvered	Louvered
Tube Type	Rifled	Rifled	Rifled	Rifled
Tube Size in. [mm] OD	0.375 [9.5]	0.375 [9.5]	0.375 [9.5]	0.375 [9.5]
Face Area sq. ft. [sq. m]	14.8 [1.37]	14.8 [1.37]	16.65 [1.55]	16.65 [1.55]
Rows / FPI [FPcm]	1 / 22 [9]	1 / 22 [9]	1 / 22 [9]	1 / 22 [9]
Indoor Coil—Fin Type	Louvered	Louvered	Louvered	Louvered
Tube Type	Rifled	Rifled	Rifled	Rifled
Tube Size in. [mm]	0.375 [9.5]	0.375 [9.5]	0.375 [9.5]	0.375 [9.5]
Face Area sq. ft. [sq. m]	5.54 [0.51]	5.54 [0.51]	7.39 [0.69]	7.39 [0.69]
Rows / FPI [FPcm]	2 / 15 [6]	2 / 15 [6]	2 / 15 [6]	2 / 15 [6]
Refrigerant Control	TX Valves	TX Valves	TX Valves	TX Valves
Drain Connection No./Size in. [mm]	1/0.75 [19.05]	1/0.75 [19.05]	1/0.75 [19.05]	1/0.75 [19.05]
Outdoor Fan—Type	Propeller	Propeller	Propeller	Propeller
No. Used/Diameter in. [mm]	1/22 [558.8]	1/22 [558.8]	1/22 [558.8]	1/22 [558.8]
Drive Type/No. Speeds	Direct/1	Direct/1	Direct/1	Direct/1
CFM [L/s]	2700 [1274]	2700 [1274]	3500 [1652]	3500 [1652]
No. Motors/HP	1 at 1/3 HP	1 at 1/3 HP	1 at 1/3 HP	1 at 1/3 HP
Motor RPM	1075	1075	1075	1075
Indoor Fan—Type	FC Centrifugal	FC Centrifugal	FC Centrifugal	FC Centrifugal
No. Used/Diameter in. [mm]	1/10x9 [254x229]	1/10x9 [254x229]	1/10x9 [254x229]	1/10x9 [254x229]
Drive Type/No. Speeds	Direct/3	Direct/3	Direct/3	Direct/3
No. Motors	1	1	1	1
Motor HP	1/2	1/2	1/2	1/2
Motor RPM	1075	1075	1075	1075
Motor Frame Size	48	48	48	48
Filter—Type	Field Supplied	Field Supplied	Field Supplied	Field Supplied
Furnished	No	No	No	No
(No.) Size Recommended in. [mm]	(1)1x24x24 [25x610x610]	(1)1x24x24 [25x610x610]	(1)1x24x24 [25x610x610]	(1)1x24x24 [25x610x610]
Refrigerant Charge Oz. [g]	92.8 [2631]	92.8 [2631]	112 [3175]	112 [3175]
Weights				
Net Weight lbs. [kg]	422 [191]	426 [193]	422 [191]	427 [194]
Ship Weight lbs. [kg]	462 [210]	466 [211]	462 [210]	467 [212]

See Page 28 for Notes.

[] Designates Metric Conversions



NOMINAL SIZES 2-5 TONS [7.0-17.6 kW]

Model RRNL- Series	B042CK08	B042CK10	B042JK04(E/X)	B042JK06(E/X)
Cooling Performance¹				CONTINUED →
Gross Cooling Capacity Btu [kW]	44,000 [12.89]	44,000 [12.89]	44,000 [12.89]	44,000 [12.89]
EER/SEER ²	11.2/13	11.2/13	11.2/13	11.2/13
Nominal CFM/AHRI Rated CFM [L/s]	1400/1400 [661/661]	1400/1400 [661/661]	1400/1400 [661/661]	1400/1400 [661/661]
AHRI Net Cooling Capacity Btu [kW]	42,000 [12.31]	42,000 [12.31]	42,000 [12.31]	42,000 [12.31]
Net Sensible Capacity Btu [kW]	30,510 [8.94]	30,510 [8.94]	30,510 [8.94]	30,510 [8.94]
Net Latent Capacity Btu [kW]	11,490 [3.37]	11,490 [3.37]	11,490 [3.37]	11,490 [3.37]
Net System Power [kW]	3.73	3.73	3.73	3.73
Heating Performance (Package Gas/Electric)³				
Heating Input Btu [kW]	80,000 [23.44]	100,000 [29.3]	40,000 [11.72]	60,000 [17.58]
Heating Output Btu [kW]	64,800 [18.99]	81,000 [23.73]	31,000 [9.08]	47,000 [13.77]
Temperature Rise Range °F [°C]	40-70 [22.2/38.9]	45-85 [25/47.2]	20-50 [11.1/27.8]	30-60 [16.7/33.3]
AFUE (%) ⁴	80	80	80	80
Steady State Efficiency (%)	81	81	81	81
No. Burners	4	5	2	3
No. Stages	1	1	1	1
Gas Connection Pipe Size in. [mm]	0.5 [12.7]	0.5 [12.7]	0.5 [12.7]	0.5 [12.7]
Compressor				
No./Type	1/Scroll	1/Scroll	1/Scroll	1/Scroll
Outdoor Sound Rating (dB)⁵	76	76	76	76
Outdoor Coil—Fin Type	Louvered	Louvered	Louvered	Louvered
Tube Type	Rifled	Rifled	Rifled	Rifled
Tube Size in. [mm] OD	0.375 [9.5]	0.375 [9.5]	0.375 [9.5]	0.375 [9.5]
Face Area sq. ft. [sq. m]	16.65 [1.55]	16.65 [1.55]	16.65 [1.55]	16.65 [1.55]
Rows / FPI [FPcm]	1 / 22 [9]	1 / 22 [9]	1 / 22 [9]	1 / 22 [9]
Indoor Coil—Fin Type	Louvered	Louvered	Louvered	Louvered
Tube Type	Rifled	Rifled	Rifled	Rifled
Tube Size in. [mm]	0.375 [9.5]	0.375 [9.5]	0.375 [9.5]	0.375 [9.5]
Face Area sq. ft. [sq. m]	7.39 [0.69]	7.39 [0.69]	7.39 [0.69]	7.39 [0.69]
Rows / FPI [FPcm]	2 / 15 [6]	2 / 15 [6]	2 / 15 [6]	2 / 15 [6]
Refrigerant Control	TX Valves	TX Valves	TX Valves	TX Valves
Drain Connection No./Size in. [mm]	1/0.75 [19.05]	1/0.75 [19.05]	1/0.75 [19.05]	1/0.75 [19.05]
Outdoor Fan—Type	Propeller	Propeller	Propeller	Propeller
No. Used/Diameter in. [mm]	1/22 [558.8]	1/22 [558.8]	1/22 [558.8]	1/22 [558.8]
Drive Type/No. Speeds	Direct/1	Direct/1	Direct/1	Direct/1
CFM [L/s]	3500 [1652]	3500 [1652]	3500 [1652]	3500 [1652]
No. Motors/HP	1 at 1/3 HP	1 at 1/3 HP	1 at 1/3 HP	1 at 1/3 HP
Motor RPM	1075	1075	1075	1075
Indoor Fan—Type	FC Centrifugal	FC Centrifugal	FC Centrifugal	FC Centrifugal
No. Used/Diameter in. [mm]	1/10x9 [254x229]	1/10x9 [254x229]	1/10x9 [254x229]	1/10x9 [254x229]
Drive Type/No. Speeds	Direct/3	Direct/3	Direct/3	Direct/3
No. Motors	1	1	1	1
Motor HP	1/2	1/2	1/2	1/2
Motor RPM	1075	1075	1075	1075
Motor Frame Size	48	48	48	48
Filter—Type	Field Supplied	Field Supplied	Field Supplied	Field Supplied
Furnished	No	No	No	No
(No.) Size Recommended in. [mm]	(1)1x24x24 [25x610x610]	(1)1x24x24 [25x610x610]	(1)1x24x24 [25x610x610]	(1)1x24x24 [25x610x610]
Refrigerant Charge Oz. [g]	112 [3175]	112 [3175]	112 [3175]	112 [3175]
Weights				
Net Weight lbs. [kg]	432 [196]	437 [198]	422 [191]	427 [194]
Ship Weight lbs. [kg]	472 [214]	477 [216]	462 [210]	467 [212]

See Page 28 for Notes.

[] Designates Metric Conversions



NOMINAL SIZES 2-5 TONS [7.0-17.6 kW]

Model RRNL- Series	B042JK08(E/X)	B042JK10(E/X)	B048CK06	B048CK08
Cooling Performance¹				CONTINUED →
Gross Cooling Capacity Btu [kW]	44,000 [12.89]	44,000 [12.89]	50,000 [14.65]	50,000 [14.65]
EER/SEER ²	11.2/13	11.2/13	11.2/13	11.2/13
Nominal CFM/AHRI Rated CFM [L/s]	1400/1400 [661/661]	1400/1400 [661/661]	1600/1600 [755/755]	1600/1600 [755/755]
AHRI Net Cooling Capacity Btu [kW]	42,000 [12.31]	42,000 [12.31]	48,000 [14.06]	48,000 [14.06]
Net Sensible Capacity Btu [kW]	30,510 [8.94]	30,510 [8.94]	33,990 [9.96]	33,990 [9.96]
Net Latent Capacity Btu [kW]	11,490 [3.37]	11,490 [3.37]	14,010 [4.1]	14,010 [4.1]
Net System Power [kW]	3.73	3.73	4.28	4.28
Heating Performance (Package Gas/Electric)³				
Heating Input Btu [kW]	80,000 [23.44]	100,000 [29.3]	60,000 [17.58]	80,000 [23.44]
Heating Output Btu [kW]	62,000 [18.17]	77,000 [22.56]	48,600 [14.24]	64,800 [18.99]
Temperature Rise Range °F [°C]	40-70 [22.2/38.9]	45-85 [25/47.2]	30-60 [16.7/33.3]	40-70 [22.2/38.9]
AFUE (%) ⁴	80	80	80	80
Steady State Efficiency (%)	81	81	81	81
No. Burners	4	5	3	4
No. Stages	1	1	1	1
Gas Connection Pipe Size in. [mm]	0.5 [12.7]	0.5 [12.7]	0.5 [12.7]	0.5 [12.7]
Compressor				
No./Type	1/Scroll	1/Scroll	1/Scroll	1/Scroll
Outdoor Sound Rating (dB)⁵	76	76	78	78
Outdoor Coil—Fin Type	Louvered	Louvered	Louvered	Louvered
Tube Type	Rifled	Rifled	Rifled	Rifled
Tube Size in. [mm] OD	0.375 [9.5]	0.375 [9.5]	0.375 [9.5]	0.375 [9.5]
Face Area sq. ft. [sq. m]	16.65 [1.55]	16.65 [1.55]	16.23 [1.51]	16.23 [1.51]
Rows / FPI [FPcm]	1 / 22 [9]	1 / 22 [9]	2 / 22 [9]	2 / 22 [9]
Indoor Coil—Fin Type	Louvered	Louvered	Louvered	Louvered
Tube Type	Rifled	Rifled	Rifled	Rifled
Tube Size in. [mm]	0.375 [9.5]	0.375 [9.5]	0.375 [9.5]	0.375 [9.5]
Face Area sq. ft. [sq. m]	7.39 [0.69]	7.39 [0.69]	7.39 [0.69]	7.39 [0.69]
Rows / FPI [FPcm]	2 / 15 [6]	2 / 15 [6]	2 / 15 [6]	2 / 15 [6]
Refrigerant Control	TX Valves	TX Valves	TX Valves	TX Valves
Drain Connection No./Size in. [mm]	1/0.75 [19.05]	1/0.75 [19.05]	1/0.75 [19.05]	1/0.75 [19.05]
Outdoor Fan—Type	Propeller	Propeller	Propeller	Propeller
No. Used/Diameter in. [mm]	1/22 [558.8]	1/22 [558.8]	1/22 [558.8]	1/22 [558.8]
Drive Type/No. Speeds	Direct/1	Direct/1	Direct/1	Direct/1
CFM [L/s]	3500 [1652]	3500 [1652]	3300 [1557]	3300 [1557]
No. Motors/HP	1 at 1/3 HP	1 at 1/3 HP	1 at 1/3 HP	1 at 1/3 HP
Motor RPM	1075	1075	1075	1075
Indoor Fan—Type	FC Centrifugal	FC Centrifugal	FC Centrifugal	FC Centrifugal
No. Used/Diameter in. [mm]	1/10x9 [254x229]	1/10x9 [254x229]	1/10x9 [254x229]	1/10x9 [254x229]
Drive Type/No. Speeds	Direct/3	Direct/3	Direct/3	Direct/3
No. Motors	1	1	1	1
Motor HP	1/2	1/2	3/4	3/4
Motor RPM	1075	1075	1075	1075
Motor Frame Size	48	48	48	48
Filter—Type	Field Supplied	Field Supplied	Field Supplied	Field Supplied
Furnished	No	No	No	No
(No.) Size Recommended in. [mm]	(1)1x24x24 [25x610x610]	(1)1x24x24 [25x610x610]	(1)1x24x24 [25x610x610]	(1)1x24x24 [25x610x610]
Refrigerant Charge Oz. [g]	112 [3175]	112 [3175]	161.2 [4570]	161.2 [4570]
Weights				
Net Weight lbs. [kg]	432 [196]	437 [198]	452 [205]	457 [207]
Ship Weight lbs. [kg]	472 [214]	477 [216]	492 [223]	497 [225]

See Page 28 for Notes.

[] Designates Metric Conversions



NOMINAL SIZES 2-5 TONS [7.0-17.6 kW]

Model RRNL- Series	B048CK10	B048DK10	B048JK06(E/X)	B048JK08(E/X)
Cooling Performance¹				CONTINUED →
Gross Cooling Capacity Btu [kW]	50,000 [14.65]	50,000 [14.65]	50,000 [14.65]	50,000 [14.65]
EER/SEER ²	11.2/13	11.2/13	11.2/13	11.2/13
Nominal CFM/AHRI Rated CFM [L/s]	1600/1600 [755/755]	1600/1600 [755/755]	1600/1600 [755/755]	1600/1600 [755/755]
AHRI Net Cooling Capacity Btu [kW]	48,000 [14.06]	48,000 [14.06]	48,000 [14.06]	48,000 [14.06]
Net Sensible Capacity Btu [kW]	33,990 [9.96]	33,990 [9.96]	33,990 [9.96]	33,990 [9.96]
Net Latent Capacity Btu [kW]	14,010 [4.1]	14,010 [4.1]	14,010 [4.1]	14,010 [4.1]
Net System Power [kW]	4.28	4.28	4.28	4.28
Heating Performance (Package Gas/Electric)³				
Heating Input Btu [kW]	100,000 [29.3]	100,000 [29.3]	60,000 [17.58]	80,000 [23.44]
Heating Output Btu [kW]	81,000 [23.73]	81,000 [23.73]	47,000 [13.77]	62,000 [18.17]
Temperature Rise Range °F [°C]	45-85 [25/47.2]	45-85 [25/47.2]	30-60 [16.7/33.3]	40-70 [22.2/38.9]
AFUE (%) ⁴	80	80	80	80
Steady State Efficiency (%)	81	81	81	81
No. Burners	5	5	3	4
No. Stages	1	1	1	1
Gas Connection Pipe Size in. [mm]	0.5 [12.7]	0.5 [12.7]	0.5 [12.7]	0.5 [12.7]
Compressor				
No./Type	1/Scroll	1/Scroll	1/Scroll	1/Scroll
Outdoor Sound Rating (dB)⁵	78	78	78	78
Outdoor Coil—Fin Type	Louvered	Louvered	Louvered	Louvered
Tube Type	Rifled	Rifled	Rifled	Rifled
Tube Size in. [mm] OD	0.375 [9.5]	0.375 [9.5]	0.375 [9.5]	0.375 [9.5]
Face Area sq. ft. [sq. m]	16.23 [1.51]	16.23 [1.51]	16.23 [1.51]	16.23 [1.51]
Rows / FPI [FPcm]	2 / 22 [9]	2 / 22 [9]	2 / 22 [9]	2 / 22 [9]
Indoor Coil—Fin Type	Louvered	Louvered	Louvered	Louvered
Tube Type	Rifled	Rifled	Rifled	Rifled
Tube Size in. [mm]	0.375 [9.5]	0.375 [9.5]	0.375 [9.5]	0.375 [9.5]
Face Area sq. ft. [sq. m]	7.39 [0.69]	7.39 [0.69]	7.39 [0.69]	7.39 [0.69]
Rows / FPI [FPcm]	2 / 15 [6]	2 / 15 [6]	2 / 15 [6]	2 / 15 [6]
Refrigerant Control	TX Valves	TX Valves	TX Valves	TX Valves
Drain Connection No./Size in. [mm]	1/0.75 [19.05]	1/0.75 [19.05]	1/0.75 [19.05]	1/0.75 [19.05]
Outdoor Fan—Type	Propeller	Propeller	Propeller	Propeller
No. Used/Diameter in. [mm]	1/22 [558.8]	1/22 [558.8]	1/22 [558.8]	1/22 [558.8]
Drive Type/No. Speeds	Direct/1	Direct/1	Direct/1	Direct/1
CFM [L/s]	3300 [1557]	3300 [1557]	3300 [1557]	3300 [1557]
No. Motors/HP	1 at 1/3 HP	1 at 1/3 HP	1 at 1/3 HP	1 at 1/3 HP
Motor RPM	1075	1075	1075	1075
Indoor Fan—Type	FC Centrifugal	FC Centrifugal	FC Centrifugal	FC Centrifugal
No. Used/Diameter in. [mm]	1/10x9 [254x229]	1/10x9 [254x229]	1/10x9 [254x229]	1/10x9 [254x229]
Drive Type/No. Speeds	Direct/3	Direct/2	Direct/3	Direct/3
No. Motors	1	1	1	1
Motor HP	3/4	3/4	3/4	3/4
Motor RPM	1075	1075	1075	1075
Motor Frame Size	48	48	48	48
Filter—Type	Field Supplied	Field Supplied	Field Supplied	Field Supplied
Furnished	No	No	No	No
(No.) Size Recommended in. [mm]	(1)1x24x24 [25x610x610]	(1)1x24x24 [25x610x610]	(1)1x24x24 [25x610x610]	(1)1x24x24 [25x610x610]
Refrigerant Charge Oz. [g]	161.2 [4570]	161.2 [4570]	161.2 [4570]	161.2 [4570]
Weights				
Net Weight lbs. [kg]	462 [210]	462 [210]	461 [209]	466 [211]
Ship Weight lbs. [kg]	502 [228]	502 [228]	501 [227]	506 [230]

See Page 28 for Notes.

[] Designates Metric Conversions

**NOMINAL SIZES 2-5 TONS [7.0-17.6 kW]**

Model RRNL- Series	B048JK10(E/X)	C060CK10	C060JK10(E/X)
Cooling Performance¹			
Gross Cooling Capacity Btu [kW]	50,000 [14.65]	59,500 [17.43]	59,500 [17.43]
EER/SEER ²	11.2/13	10.5/13	10.5/13
Nominal CFM/AHRI Rated CFM [L/s]	1600/1600 [755/755]	2000/1850 [944/873]	1900/1850 [897/873]
AHRI Net Cooling Capacity Btu [kW]	48,000 [14.06]	57,500 [16.85]	57,500 [16.85]
Net Sensible Capacity Btu [kW]	33,990 [9.96]	40,460 [11.85]	40,460 [11.85]
Net Latent Capacity Btu [kW]	14,010 [4.1]	17,040 [4.99]	17,040 [4.99]
Net System Power [kW]	4.28	5.48	5.48
Heating Performance (Package Gas/Electric)³			
Heating Input Btu [kW]	100,000 [29.3]	100,000 [29.3]	100,000 [29.3]
Heating Output Btu [kW]	77,000 [22.56]	81,000 [23.73]	77,000 [22.56]
Temperature Rise Range °F [°C]	45-85 [25/47.2]	45-85 [25/47.2]	45-85 [25/47.2]
AFUE (%) ⁴	80	80	80
Steady State Efficiency (%)	81	81	81
No. Burners	5	5	5
No. Stages	1	1	1
Gas Connection Pipe Size in. [mm]	0.5 [12.7]	0.5 [12.7]	0.5 [12.7]
Compressor			
No./Type	1/Scroll	1/Scroll	1/Scroll
Outdoor Sound Rating (dB)⁵			
	78	78	78
Outdoor Coil—Fin Type			
Tube Type	Louvered	Louvered	Louvered
Tube Type	Rifled	Rifled	Rifled
Tube Size in. [mm] OD	0.375 [9.5]	0.375 [9.5]	0.375 [9.5]
Face Area sq. ft. [sq. m]	16.23 [1.51]	16.23 [1.51]	16.23 [1.51]
Rows / FPI [FPcm]	2 / 22 [9]	2 / 22 [9]	2 / 22 [9]
Indoor Coil—Fin Type			
Tube Type	Louvered	Louvered	Louvered
Tube Type	Rifled	Rifled	Rifled
Tube Size in. [mm]	0.375 [9.5]	0.375 [9.5]	0.375 [9.5]
Face Area sq. ft. [sq. m]	7.39 [0.69]	7.39 [0.69]	7.39 [0.69]
Rows / FPI [FPcm]	2 / 15 [6]	2 / 15 [6]	2 / 15 [6]
Refrigerant Control	TX Valves	TX Valves	TX Valves
Drain Connection No./Size in. [mm]	1/0.75 [19.05]	1/0.75 [19.05]	1/0.75 [19.05]
Outdoor Fan—Type			
	Propeller	Propeller	Propeller
No. Used/Diameter in. [mm]	1/22 [558.8]	1/22 [558.8]	1/22 [558.8]
Drive Type/No. Speeds	Direct/1	Direct/1	Direct/1
CFM [L/s]	3300 [1557]	3300 [1557]	3300 [1557]
No. Motors/HP	1 at 1/3 HP	1 at 1/3 HP	1 at 1/3 HP
Motor RPM	1075	1075	1075
Indoor Fan—Type			
	FC Centrifugal	FC Centrifugal	FC Centrifugal
No. Used/Diameter in. [mm]	1/10x9 [254x229]	1/12x9 [305x229]	1/12x9 [305x229]
Drive Type/No. Speeds	Direct/3	Direct/3	Direct/3
No. Motors	1	1	1
Motor HP	3/4	1	1
Motor RPM	1075	1075	1075
Motor Frame Size	48	48	48
Filter—Type			
Furnished	Field Supplied	Field Supplied	Field Supplied
	No	No	No
(No.) Size Recommended in. [mm]	(1)1x24x24 [25x610x610]	(1)1x24x30 [25x610x762]	(1)1x24x30 [25x610x762]
Refrigerant Charge Oz. [g]			
	161.2 [4570]	172.8 [4899]	172.8 [4899]
Weights			
Net Weight lbs. [kg]	471 [214]	532 [241]	532 [241]
Ship Weight lbs. [kg]	511 [232]	577 [262]	577 [262]

See Page 28 for Notes.

[] Designates Metric Conversions



NOMINAL SIZES 2-5 TONS [7.0-17.6 kW]

Model RRPL- Series	B024JK04(E/X)	B024JK06(E/X)	B024JK08(E/X)	B030JK04(E/X)
Cooling Performance¹				CONTINUED →
Gross Cooling Capacity Btu [kW]	24,400 [7.15]	24,400 [7.15]	24,400 [7.15]	29,600 [8.67]
EER/SEER ²	12/14	12/14	12/14	12/14
Nominal CFM/AHRI Rated CFM [L/s]	800/800 [378/378]	800/800 [378/378]	800/800 [378/378]	967/1000 [456/472]
AHRI Net Cooling Capacity Btu [kW]	24,000 [7.03]	24,000 [7.03]	24,000 [7.03]	29,200 [8.56]
Net Sensible Capacity Btu [kW]	17,790 [5.21]	17,790 [5.21]	17,790 [5.21]	21,700 [6.36]
Net Latent Capacity Btu [kW]	6,210 [1.82]	6,210 [1.82]	6,210 [1.82]	7,500 [2.2]
Net System Power [kW]	2.01	2.01	2.01	2.43
Heating Performance (Package Gas/Electric)³				
Heating Input Btu [kW]	40,000 [11.72]	60,000 [17.58]	80,000 [23.44]	40,000 [11.72]
Heating Output Btu [kW]	31,000 [9.08]	47,000 [13.77]	62,000 [18.17]	31,000 [9.08]
Temperature Rise Range °F [°C]	30-60 [16.7/33.3]	40-70 [22.2/38.9]	55-85 [30.6/47.2]	20-50 [11.1/27.8]
AFUE (%) ⁴	80	80	80	80
Steady State Efficiency (%)	81	81	81	81
No. Burners	2	3	4	2
No. Stages	1	1	1	1
Gas Connection Pipe Size in. [mm]	0.5 [12.7]	0.5 [12.7]	0.5 [12.7]	0.5 [12.7]
Compressor				
No./Type	1/Scroll	1/Scroll	1/Scroll	1/Scroll
Outdoor Sound Rating (dB)⁵	76	76	76	76
Outdoor Coil—Fin Type	Louvered	Louvered	Louvered	Louvered
Tube Type	Rifled	Rifled	Rifled	Rifled
Tube Size in. [mm] OD	0.375 [9.5]	0.375 [9.5]	0.375 [9.5]	0.375 [9.5]
Face Area sq. ft. [sq. m]	10.56 [0.98]	10.56 [0.98]	10.56 [0.98]	10.56 [0.98]
Rows / FPI [FPcm]	1 / 18 [7]	1 / 18 [7]	1 / 18 [7]	1 / 18 [7]
Indoor Coil—Fin Type	Louvered	Louvered	Louvered	Louvered
Tube Type	Rifled	Rifled	Rifled	Rifled
Tube Size in. [mm]	0.375 [9.5]	0.375 [9.5]	0.375 [9.5]	0.375 [9.5]
Face Area sq. ft. [sq. m]	5.54 [0.51]	5.54 [0.51]	5.54 [0.51]	5.54 [0.51]
Rows / FPI [FPcm]	2 / 15 [6]	2 / 15 [6]	2 / 15 [6]	2 / 15 [6]
Refrigerant Control	TX Valves	TX Valves	TX Valves	TX Valves
Drain Connection No./Size in. [mm]	1/0.75 [19.05]	1/0.75 [19.05]	1/0.75 [19.05]	1/0.75 [19.05]
Outdoor Fan—Type	Propeller	Propeller	Propeller	Propeller
No. Used/Diameter in. [mm]	1/22 [558.8]	1/22 [558.8]	1/22 [558.8]	1/22 [558.8]
Drive Type/No. Speeds	Direct/1	Direct/1	Direct/1	Direct/1
CFM [L/s]	2500 [1180]	2500 [1180]	2500 [1180]	2500 [1180]
No. Motors/HP	1 at 1/3 HP	1 at 1/3 HP	1 at 1/3 HP	1 at 1/3 HP
Motor RPM	1075	1075	1075	1075
Indoor Fan—Type	FC Centrifugal	FC Centrifugal	FC Centrifugal	FC Centrifugal
No. Used/Diameter in. [mm]	1/9x7 [229x178]	1/9x7 [229x178]	1/9x7 [229x178]	1/10x9 [254x229]
Drive Type/No. Speeds	Direct/2	Direct/2	Direct/2	Direct/3
No. Motors	1	1	1	1
Motor HP	1/3	1/3	1/3	1/2
Motor RPM	1075	1075	1075	1075
Motor Frame Size	48	48	48	48
Filter—Type	Field Supplied	Field Supplied	Field Supplied	Field Supplied
Furnished	No	No	No	No
(No.) Size Recommended in. [mm]	(1)1x20x20 [25x508x508]	(1)1x20x20 [25x508x508]	(1)1x20x20 [25x508x508]	(1)1x24x24 [25x610x610]
Refrigerant Charge Oz. [g]	77.8 [2206]	77.8 [2206]	77.8 [2206]	76.8 [2177]
Weights				
Net Weight lbs. [kg]	381 [173]	385 [175]	390 [177]	399 [181]
Ship Weight lbs. [kg]	421 [191]	425 [193]	430 [195]	439 [199]

See Page 28 for Notes.

[] Designates Metric Conversions



NOMINAL SIZES 2-5 TONS [7.0-17.6 kW]

Model RRPL- Series	B030JK06(E/X)	B030JK08(E/X)	B030JK10(E/X)	B030CK04
Cooling Performance¹				CONTINUED →
Gross Cooling Capacity Btu [kW]	29,600 [8.67]	29,600 [8.67]	29,600 [8.67]	36,800 [10.78]
EER/SEER ²	12/14	12/14	12/14	12/14
Nominal CFM/AHRI Rated CFM [L/s]	967/1000 [456/472]	967/1000 [456/472]	967/1000 [456/472]	1200/1200 [566/566]
AHRI Net Cooling Capacity Btu [kW]	29,200 [8.56]	29,200 [8.56]	29,200 [8.56]	36,000 [10.55]
Net Sensible Capacity Btu [kW]	21,700 [6.36]	21,700 [6.36]	21,700 [6.36]	26,420 [7.74]
Net Latent Capacity Btu [kW]	7,500 [2.2]	7,500 [2.2]	7,500 [2.2]	9,580 [2.81]
Net System Power [kW]	2.43	2.43	2.43	3
Heating Performance (Package Gas/Electric)³				
Heating Input Btu [kW]	60,000 [17.58]	80,000 [23.44]	100,000 [29.3]	40,000 [11.72]
Heating Output Btu [kW]	47,000 [13.77]	62,000 [18.17]	77,000 [22.56]	32,400 [9.49]
Temperature Rise Range °F [°C]	30-60 [16.7/33.3]	40-70 [22.2/38.9]	45-85 [25/47.2]	20-50 [11.1/27.8]
AFUE (%) ⁴	80	80	80	80
Steady State Efficiency (%)	81	81	81	81
No. Burners	3	4	5	2
No. Stages	1	1	1	1
Gas Connection Pipe Size in. [mm]	0.5 [12.7]	0.5 [12.7]	0.5 [12.7]	0.5 [12.7]
Compressor				
No./Type	1/Scroll	1/Scroll	1/Scroll	1/Scroll
Outdoor Sound Rating (dB)⁵	76	76	76	76
Outdoor Coil—Fin Type	Louvered	Louvered	Louvered	Louvered
Tube Type	Rifled	Rifled	Rifled	Rifled
Tube Size in. [mm] OD	0.375 [9.5]	0.375 [9.5]	0.375 [9.5]	0.375 [9.5]
Face Area sq. ft. [sq. m]	10.56 [0.98]	10.56 [0.98]	10.56 [0.98]	14.8 [1.37]
Rows / FPI [FPcm]	1 / 18 [7]	1 / 18 [7]	1 / 18 [7]	1 / 22 [9]
Indoor Coil—Fin Type	Louvered	Louvered	Louvered	Louvered
Tube Type	Rifled	Rifled	Rifled	Rifled
Tube Size in. [mm]	0.375 [9.5]	0.375 [9.5]	0.375 [9.5]	0.375 [9.5]
Face Area sq. ft. [sq. m]	5.54 [0.51]	5.54 [0.51]	5.54 [0.51]	5.54 [0.51]
Rows / FPI [FPcm]	2 / 15 [6]	2 / 15 [6]	2 / 15 [6]	2 / 15 [6]
Refrigerant Control	TX Valves	TX Valves	TX Valves	TX Valves
Drain Connection No./Size in. [mm]	1/0.75 [19.05]	1/0.75 [19.05]	1/0.75 [19.05]	1/0.75 [19.05]
Outdoor Fan—Type	Propeller	Propeller	Propeller	Propeller
No. Used/Diameter in. [mm]	1/22 [558.8]	1/22 [558.8]	1/22 [558.8]	1/22 [558.8]
Drive Type/No. Speeds	Direct/1	Direct/1	Direct/1	Direct/1
CFM [L/s]	2500 [1180]	2500 [1180]	2500 [1180]	2700 [1274]
No. Motors/HP	1 at 1/3 HP	1 at 1/3 HP	1 at 1/3 HP	1 at 1/3 HP
Motor RPM	1075	1075	1075	1075
Indoor Fan—Type	FC Centrifugal	FC Centrifugal	FC Centrifugal	FC Centrifugal
No. Used/Diameter in. [mm]	1/10x9 [254x229]	1/10x9 [254x229]	1/10x9 [254x229]	1/10x9 [254x229]
Drive Type/No. Speeds	Direct/3	Direct/3	Direct/3	Direct/3
No. Motors	1	1	1	1
Motor HP	1/2	1/2	1/2	1/2
Motor RPM	1075	1075	1075	1075
Motor Frame Size	48	48	48	48
Filter—Type	Field Supplied	Field Supplied	Field Supplied	Field Supplied
Furnished	No	No	No	No
(No.) Size Recommended in. [mm]	(1)1x24x24 [25x610x610]	(1)1x24x24 [25x610x610]	(1)1x24x24 [25x610x610]	(1)1x24x24 [25x610x610]
Refrigerant Charge Oz. [g]	76.8 [2177]	76.8 [2177]	76.8 [2177]	92.8 [2631]
Weights				
Net Weight lbs. [kg]	404 [183]	409 [186]	414 [188]	412 [187]
Ship Weight lbs. [kg]	444 [201]	449 [204]	454 [206]	452 [205]

See Page 28 for Notes.

[] Designates Metric Conversions



NOMINAL SIZES 2-5 TONS [7.0-17.6 kW]

Model RRPL- Series	B036CK06	B036CK08	B036CK10	B036JK04(E/X)
Cooling Performance¹				CONTINUED →
Gross Cooling Capacity Btu [kW]	36,800 [10.78]	36,800 [10.78]	36,800 [10.78]	36,800 [10.78]
EER/SEER ²	12/14	12/14	12/14	12/14
Nominal CFM/AHRI Rated CFM [L/s]	1200/1200 [566/566]	1200/1200 [566/566]	1200/1200 [566/566]	1200/1200 [566/566]
AHRI Net Cooling Capacity Btu [kW]	36,000 [10.55]	36,000 [10.55]	36,000 [10.55]	36,000 [10.55]
Net Sensible Capacity Btu [kW]	26,420 [7.74]	26,420 [7.74]	26,420 [7.74]	26,420 [7.74]
Net Latent Capacity Btu [kW]	9,580 [2.81]	9,580 [2.81]	9,580 [2.81]	9,580 [2.81]
Net System Power [kW]	3	3	3	3
Heating Performance (Package Gas/Electric)³				
Heating Input Btu [kW]	60,000 [17.58]	80,000 [23.44]	100,000 [29.3]	40,000 [11.72]
Heating Output Btu [kW]	48,600 [14.24]	64,800 [18.99]	81,000 [23.73]	31,000 [9.08]
Temperature Rise Range °F [°C]	30-60 [16.7/33.3]	40-70 [22.2/38.9]	45-85 [25/47.2]	20-50 [11.1/27.8]
AFUE (%) ⁴	80	80	80	80
Steady State Efficiency (%)	81	81	81	81
No. Burners	3	4	5	2
No. Stages	1	1	1	1
Gas Connection Pipe Size in. [mm]	0.5 [12.7]	0.5 [12.7]	0.5 [12.7]	0.5 [12.7]
Compressor				
No./Type	1/Scroll	1/Scroll	1/Scroll	1/Scroll
Outdoor Sound Rating (dB)⁵	76	76	76	76
Outdoor Coil—Fin Type	Louvered	Louvered	Louvered	Louvered
Tube Type	Rifled	Rifled	Rifled	Rifled
Tube Size in. [mm] OD	0.375 [9.5]	0.375 [9.5]	0.375 [9.5]	0.375 [9.5]
Face Area sq. ft. [sq. m]	14.8 [1.37]	14.8 [1.37]	14.8 [1.37]	14.8 [1.37]
Rows / FPI [FPcm]	1 / 22 [9]	1 / 22 [9]	1 / 22 [9]	1 / 22 [9]
Indoor Coil—Fin Type	Louvered	Louvered	Louvered	Louvered
Tube Type	Rifled	Rifled	Rifled	Rifled
Tube Size in. [mm]	0.375 [9.5]	0.375 [9.5]	0.375 [9.5]	0.375 [9.5]
Face Area sq. ft. [sq. m]	5.54 [0.51]	5.54 [0.51]	5.54 [0.51]	5.54 [0.51]
Rows / FPI [FPcm]	2 / 15 [6]	2 / 15 [6]	2 / 15 [6]	2 / 15 [6]
Refrigerant Control	TX Valves	TX Valves	TX Valves	TX Valves
Drain Connection No./Size in. [mm]	1/0.75 [19.05]	1/0.75 [19.05]	1/0.75 [19.05]	1/0.75 [19.05]
Outdoor Fan—Type	Propeller	Propeller	Propeller	Propeller
No. Used/Diameter in. [mm]	1/22 [558.8]	1/22 [558.8]	1/22 [558.8]	1/22 [558.8]
Drive Type/No. Speeds	Direct/1	Direct/1	Direct/1	Direct/1
CFM [L/s]	2700 [1274]	2700 [1274]	2700 [1274]	2700 [1274]
No. Motors/HP	1 at 1/3 HP	1 at 1/3 HP	1 at 1/3 HP	1 at 1/3 HP
Motor RPM	1075	1075	1075	1075
Indoor Fan—Type	FC Centrifugal	FC Centrifugal	FC Centrifugal	FC Centrifugal
No. Used/Diameter in. [mm]	1/10x9 [254x229]	1/10x9 [254x229]	1/10x9 [254x229]	1/10x9 [254x229]
Drive Type/No. Speeds	Direct/3	Direct/3	Direct/3	Direct/3
No. Motors	1	1	1	1
Motor HP	1/2	1/2	1/2	1/2
Motor RPM	1075	1075	1075	1075
Motor Frame Size	48	48	48	48
Filter—Type	Field Supplied	Field Supplied	Field Supplied	Field Supplied
Furnished	No	No	No	No
(No.) Size Recommended in. [mm]	(1)1x24x24 [25x610x610]	(1)1x24x24 [25x610x610]	(1)1x24x24 [25x610x610]	(1)1x24x24 [25x610x610]
Refrigerant Charge Oz. [g]	92.8 [2631]	92.8 [2631]	92.8 [2631]	92.8 [2631]
Weights				
Net Weight lbs. [kg]	417 [189]	422 [191]	426 [193]	412 [187]
Ship Weight lbs. [kg]	457 [207]	462 [210]	466 [211]	452 [205]

See Page 28 for Notes.

[] Designates Metric Conversions



NOMINAL SIZES 2-5 TONS [7.0-17.6 kW]

Model RRPL- Series	B036JK06(E/X)	B036JK08(E/X)	B036JK10(E/X)	B042CK04
Cooling Performance¹				CONTINUED →
Gross Cooling Capacity Btu [kW]	36,800 [10.78]	36,800 [10.78]	36,800 [10.78]	44,000 [12.89]
EER/SEER ²	12/14	12/14	12/14	12/14
Nominal CFM/AHRI Rated CFM [L/s]	1200/1200 [566/566]	1200/1200 [566/566]	1200/1200 [566/566]	1400/1400 [661/661]
AHRI Net Cooling Capacity Btu [kW]	36,000 [10.55]	36,000 [10.55]	36,000 [10.55]	43,000 [12.6]
Net Sensible Capacity Btu [kW]	26,420 [7.74]	26,420 [7.74]	26,420 [7.74]	31,270 [9.16]
Net Latent Capacity Btu [kW]	9,580 [2.81]	9,580 [2.81]	9,580 [2.81]	11,730 [3.44]
Net System Power [kW]	3	3	3	3.58
Heating Performance (Package Gas/Electric)³				
Heating Input Btu [kW]	60,000 [17.58]	80,000 [23.44]	100,000 [29.3]	40,000 [11.72]
Heating Output Btu [kW]	47,000 [13.77]	62,000 [18.17]	77,000 [22.56]	32,400 [9.49]
Temperature Rise Range °F [°C]	30-60 [16.7/33.3]	40-70 [22.2/38.9]	45-85 [25/47.2]	20-50 [11.1/27.8]
AFUE (%) ⁴	80	80	80	80
Steady State Efficiency (%)	81	81	81	81
No. Burners	3	4	5	2
No. Stages	1	1	1	1
Gas Connection Pipe Size in. [mm]	0.5 [12.7]	0.5 [12.7]	0.5 [12.7]	0.5 [12.7]
Compressor				
No./Type	1/Scroll	1/Scroll	1/Scroll	1/Scroll
Outdoor Sound Rating (dB)⁵	76	76	76	76
Outdoor Coil—Fin Type	Louvered	Louvered	Louvered	Louvered
Tube Type	Rifled	Rifled	Rifled	Rifled
Tube Size in. [mm] OD	0.375 [9.5]	0.375 [9.5]	0.375 [9.5]	0.375 [9.5]
Face Area sq. ft. [sq. m]	14.8 [1.37]	14.8 [1.37]	14.8 [1.37]	16.65 [1.55]
Rows / FPI [FPcm]	1 / 22 [9]	1 / 22 [9]	1 / 22 [9]	1 / 22 [9]
Indoor Coil—Fin Type	Louvered	Louvered	Louvered	Louvered
Tube Type	Rifled	Rifled	Rifled	Rifled
Tube Size in. [mm]	0.375 [9.5]	0.375 [9.5]	0.375 [9.5]	0.375 [9.5]
Face Area sq. ft. [sq. m]	5.54 [0.51]	5.54 [0.51]	5.54 [0.51]	7.39 [0.69]
Rows / FPI [FPcm]	2 / 15 [6]	2 / 15 [6]	2 / 15 [6]	2 / 15 [6]
Refrigerant Control	TX Valves	TX Valves	TX Valves	TX Valves
Drain Connection No./Size in. [mm]	1/0.75 [19.05]	1/0.75 [19.05]	1/0.75 [19.05]	1/0.75 [19.05]
Outdoor Fan—Type	Propeller	Propeller	Propeller	Propeller
No. Used/Diameter in. [mm]	1/22 [558.8]	1/22 [558.8]	1/22 [558.8]	1/22 [558.8]
Drive Type/No. Speeds	Direct/1	Direct/1	Direct/1	Direct/1
CFM [L/s]	2700 [1274]	2700 [1274]	2700 [1274]	3500 [1652]
No. Motors/HP	1 at 1/3 HP	1 at 1/3 HP	1 at 1/3 HP	1 at 1/3 HP
Motor RPM	1075	1075	1075	1075
Indoor Fan—Type	FC Centrifugal	FC Centrifugal	FC Centrifugal	FC Centrifugal
No. Used/Diameter in. [mm]	1/10x9 [254x229]	1/10x9 [254x229]	1/10x9 [254x229]	1/10x9 [254x229]
Drive Type/No. Speeds	Direct/3	Direct/3	Direct/3	Direct/3
No. Motors	1	1	1	1
Motor HP	1/2	1/2	1/2	1/2
Motor RPM	1075	1075	1075	1075
Motor Frame Size	48	48	48	48
Filter—Type	Field Supplied	Field Supplied	Field Supplied	Field Supplied
Furnished	No	No	No	No
(No.) Size Recommended in. [mm]	(1)1x24x24 [25x610x610]	(1)1x24x24 [25x610x610]	(1)1x24x24 [25x610x610]	(1)1x24x24 [25x610x610]
Refrigerant Charge Oz. [g]	92.8 [2631]	92.8 [2631]	92.8 [2631]	112 [3175]
Weights				
Net Weight lbs. [kg]	417 [189]	422 [191]	426 [193]	422 [191]
Ship Weight lbs. [kg]	457 [207]	462 [210]	466 [211]	462 [210]

See Page 28 for Notes.

[] Designates Metric Conversions



NOMINAL SIZES 2-5 TONS [7.0-17.6 kW]

Model RRPL- Series	B042CK06	B042CK08	B042CK10	B042JK04(E/X)
Cooling Performance¹				CONTINUED →
Gross Cooling Capacity Btu [kW]	44,000 [12.89]	44,000 [12.89]	44,000 [12.89]	44,000 [12.89]
EER/SEER ²	12/14	12/14	12/14	12/14
Nominal CFM/AHRI Rated CFM [L/s]	1400/1400 [661/661]	1400/1400 [661/661]	1400/1400 [661/661]	1400/1400 [661/661]
AHRI Net Cooling Capacity Btu [kW]	43,000 [12.6]	43,000 [12.6]	43,000 [12.6]	43,000 [12.6]
Net Sensible Capacity Btu [kW]	31,270 [9.16]	31,270 [9.16]	31,270 [9.16]	31,270 [9.16]
Net Latent Capacity Btu [kW]	11,730 [3.44]	11,730 [3.44]	11,730 [3.44]	11,730 [3.44]
Net System Power [kW]	3.58	3.58	3.58	3.58
Heating Performance (Package Gas/Electric)³				
Heating Input Btu [kW]	60,000 [17.58]	80,000 [23.44]	100,000 [29.3]	40,000 [11.72]
Heating Output Btu [kW]	48,600 [14.24]	64,800 [18.99]	81,000 [23.73]	31,000 [9.08]
Temperature Rise Range °F [°C]	30-60 [16.7/33.3]	40-70 [22.2/38.9]	45-85 [25/47.2]	20-50 [11.1/27.8]
AFUE (%) ⁴	80	80	80	80
Steady State Efficiency (%)	81	81	81	81
No. Burners	3	4	5	2
No. Stages	1	1	1	1
Gas Connection Pipe Size in. [mm]	0.5 [12.7]	0.5 [12.7]	0.5 [12.7]	0.5 [12.7]
Compressor				
No./Type	1/Scroll	1/Scroll	1/Scroll	1/Scroll
Outdoor Sound Rating (dB)⁵	76	76	76	76
Outdoor Coil—Fin Type	Louvered	Louvered	Louvered	Louvered
Tube Type	Rifled	Rifled	Rifled	Rifled
Tube Size in. [mm] OD	0.375 [9.5]	0.375 [9.5]	0.375 [9.5]	0.375 [9.5]
Face Area sq. ft. [sq. m]	16.65 [1.55]	16.65 [1.55]	16.65 [1.55]	16.65 [1.55]
Rows / FPI [FPcm]	1 / 22 [9]	1 / 22 [9]	1 / 22 [9]	1 / 22 [9]
Indoor Coil—Fin Type	Louvered	Louvered	Louvered	Louvered
Tube Type	Rifled	Rifled	Rifled	Rifled
Tube Size in. [mm]	0.375 [9.5]	0.375 [9.5]	0.375 [9.5]	0.375 [9.5]
Face Area sq. ft. [sq. m]	7.39 [0.69]	7.39 [0.69]	7.39 [0.69]	7.39 [0.69]
Rows / FPI [FPcm]	2 / 15 [6]	2 / 15 [6]	2 / 15 [6]	2 / 15 [6]
Refrigerant Control	TX Valves	TX Valves	TX Valves	TX Valves
Drain Connection No./Size in. [mm]	1/0.75 [19.05]	1/0.75 [19.05]	1/0.75 [19.05]	1/0.75 [19.05]
Outdoor Fan—Type	Propeller	Propeller	Propeller	Propeller
No. Used/Diameter in. [mm]	1/22 [558.8]	1/22 [558.8]	1/22 [558.8]	1/22 [558.8]
Drive Type/No. Speeds	Direct/1	Direct/1	Direct/1	Direct/1
CFM [L/s]	3500 [1652]	3500 [1652]	3500 [1652]	3500 [1652]
No. Motors/HP	1 at 1/3 HP	1 at 1/3 HP	1 at 1/3 HP	1 at 1/3 HP
Motor RPM	1075	1075	1075	1075
Indoor Fan—Type	FC Centrifugal	FC Centrifugal	FC Centrifugal	FC Centrifugal
No. Used/Diameter in. [mm]	1/10x9 [254x229]	1/10x9 [254x229]	1/10x9 [254x229]	1/10x9 [254x229]
Drive Type/No. Speeds	Direct/3	Direct/3	Direct/3	Direct/3
No. Motors	1	1	1	1
Motor HP	1/2	1/2	1/2	1/2
Motor RPM	1075	1075	1075	1075
Motor Frame Size	48	48	48	48
Filter—Type	Field Supplied	Field Supplied	Field Supplied	Field Supplied
Furnished	No	No	No	No
(No.) Size Recommended in. [mm]	(1)1x24x24 [25x610x610]	(1)1x24x24 [25x610x610]	(1)1x24x24 [25x610x610]	(1)1x24x24 [25x610x610]
Refrigerant Charge Oz. [g]	112 [3175]	112 [3175]	112 [3175]	112 [3175]
Weights				
Net Weight lbs. [kg]	427 [194]	432 [196]	437 [198]	422 [191]
Ship Weight lbs. [kg]	467 [212]	472 [214]	477 [216]	462 [210]

See Page 28 for Notes.

[] Designates Metric Conversions



NOMINAL SIZES 2-5 TONS [7.0-17.6 kW]

Model RRPL- Series	B042JK06(E/X)	B042JK08(E/X)	B042JK10(E/X)	B048CK06
Cooling Performance¹				CONTINUED →
Gross Cooling Capacity Btu [kW]	44,000 [12.89]	44,000 [12.89]	44,000 [12.89]	50,500 [14.8]
EER/SEER ²	12/14	12/14	12/14	12/14
Nominal CFM/AHRI Rated CFM [L/s]	1400/1400 [661/661]	1400/1400 [661/661]	1400/1400 [661/661]	1600/1600 [755/755]
AHRI Net Cooling Capacity Btu [kW]	43,000 [12.6]	43,000 [12.6]	43,000 [12.6]	49,000 [14.36]
Net Sensible Capacity Btu [kW]	31,270 [9.16]	31,270 [9.16]	31,270 [9.16]	34,990 [10.25]
Net Latent Capacity Btu [kW]	11,730 [3.44]	11,730 [3.44]	11,730 [3.44]	14,010 [4.1]
Net System Power [kW]	3.58	3.58	3.58	4.08
Heating Performance (Package Gas/Electric)³				
Heating Input Btu [kW]	60,000 [17.58]	80,000 [23.44]	100,000 [29.3]	60,000 [17.58]
Heating Output Btu [kW]	47,000 [13.77]	62,000 [18.17]	77,000 [22.56]	48,600 [14.24]
Temperature Rise Range °F [°C]	30-60 [16.7/33.3]	40-70 [22.2/38.9]	45-85 [25/47.2]	30-60 [16.7/33.3]
AFUE (%) ⁴	80	80	80	80
Steady State Efficiency (%)	81	81	81	81
No. Burners	3	4	5	3
No. Stages	1	1	1	1
Gas Connection Pipe Size in. [mm]	0.5 [12.7]	0.5 [12.7]	0.5 [12.7]	0.5 [12.7]
Compressor				
No./Type	1/Scroll	1/Scroll	1/Scroll	1/Scroll
Outdoor Sound Rating (dB)⁵	76	76	76	78
Outdoor Coil—Fin Type	Louvered	Louvered	Louvered	Louvered
Tube Type	Rifled	Rifled	Rifled	Rifled
Tube Size in. [mm] OD	0.375 [9.5]	0.375 [9.5]	0.375 [9.5]	0.375 [9.5]
Face Area sq. ft. [sq. m]	16.65 [1.55]	16.65 [1.55]	16.65 [1.55]	16.23 [1.51]
Rows / FPI [FPcm]	1 / 22 [9]	1 / 22 [9]	1 / 22 [9]	2 / 22 [9]
Indoor Coil—Fin Type	Louvered	Louvered	Louvered	Louvered
Tube Type	Rifled	Rifled	Rifled	Rifled
Tube Size in. [mm]	0.375 [9.5]	0.375 [9.5]	0.375 [9.5]	0.375 [9.5]
Face Area sq. ft. [sq. m]	7.39 [0.69]	7.39 [0.69]	7.39 [0.69]	7.39 [0.69]
Rows / FPI [FPcm]	2 / 15 [6]	2 / 15 [6]	2 / 15 [6]	2 / 15 [6]
Refrigerant Control	TX Valves	TX Valves	TX Valves	TX Valves
Drain Connection No./Size in. [mm]	1/0.75 [19.05]	1/0.75 [19.05]	1/0.75 [19.05]	1/0.75 [19.05]
Outdoor Fan—Type	Propeller	Propeller	Propeller	Propeller
No. Used/Diameter in. [mm]	1/22 [558.8]	1/22 [558.8]	1/22 [558.8]	1/22 [558.8]
Drive Type/No. Speeds	Direct/1	Direct/1	Direct/1	Direct/1
CFM [L/s]	3500 [1652]	3500 [1652]	3500 [1652]	3300 [1557]
No. Motors/HP	1 at 1/3 HP	1 at 1/3 HP	1 at 1/3 HP	1 at 1/3 HP
Motor RPM	1075	1075	1075	1075
Indoor Fan—Type	FC Centrifugal	FC Centrifugal	FC Centrifugal	FC Centrifugal
No. Used/Diameter in. [mm]	1/10x9 [254x229]	1/10x9 [254x229]	1/10x9 [254x229]	1/10x9 [254x229]
Drive Type/No. Speeds	Direct/3	Direct/3	Direct/3	Direct/3
No. Motors	1	1	1	1
Motor HP	1/2	1/2	1/2	3/4
Motor RPM	1075	1075	1075	1075
Motor Frame Size	48	48	48	48
Filter—Type	Field Supplied	Field Supplied	Field Supplied	Field Supplied
Furnished	No	No	No	No
(No.) Size Recommended in. [mm]	(1)1x24x24 [25x610x610]	(1)1x24x24 [25x610x610]	(1)1x24x24 [25x610x610]	(1)1x24x24 [25x610x610]
Refrigerant Charge Oz. [g]	112 [3175]	112 [3175]	112 [3175]	161.2 [4570]
Weights				
Net Weight lbs. [kg]	427 [194]	432 [196]	437 [198]	452 [205]
Ship Weight lbs. [kg]	467 [212]	472 [214]	477 [216]	492 [223]

See Page 28 for Notes.

[] Designates Metric Conversions



NOMINAL SIZES 2-5 TONS [7.0-17.6 kW]

Model RRPL- Series	B048CK08	B048CK10	B048JK06(E/X)	B048JK08(E/X)
Cooling Performance¹				CONTINUED →
Gross Cooling Capacity Btu [kW]	50,500 [14.8]	50,500 [14.8]	50,500 [14.8]	50,500 [14.8]
EER/SEER ²	12/14	12/14	12/14	12/14
Nominal CFM/AHRI Rated CFM [L/s]	1600/1600 [755/755]	1600/1600 [755/755]	1600/1600 [755/755]	1600/1600 [755/755]
AHRI Net Cooling Capacity Btu [kW]	49,000 [14.36]	49,000 [14.36]	49,000 [14.36]	49,000 [14.36]
Net Sensible Capacity Btu [kW]	34,990 [10.25]	34,990 [10.25]	34,990 [10.25]	34,990 [10.25]
Net Latent Capacity Btu [kW]	14,010 [4.1]	14,010 [4.1]	14,010 [4.1]	14,010 [4.1]
Net System Power [kW]	4.08	4.08	4.08	4.08
Heating Performance (Package Gas/Electric)³				
Heating Input Btu [kW]	80,000 [23.44]	100,000 [29.3]	60,000 [17.58]	80,000 [23.44]
Heating Output Btu [kW]	64,800 [18.99]	81,000 [23.73]	47,000 [13.77]	62,000 [18.17]
Temperature Rise Range °F [°C]	40-70 [22.2/38.9]	45-85 [25/47.2]	30-60 [16.7/33.3]	40-70 [22.2/38.9]
AFUE (%) ⁴	80	80	80	80
Steady State Efficiency (%)	81	81	81	81
No. Burners	4	5	3	4
No. Stages	1	1	1	1
Gas Connection Pipe Size in. [mm]	0.5 [12.7]	0.5 [12.7]	0.5 [12.7]	0.5 [12.7]
Compressor				
No./Type	1/Scroll	1/Scroll	1/Scroll	1/Scroll
Outdoor Sound Rating (dB)⁵	78	78	78	78
Outdoor Coil—Fin Type	Louvered	Louvered	Louvered	Louvered
Tube Type	Rifled	Rifled	Rifled	Rifled
Tube Size in. [mm] OD	0.375 [9.5]	0.375 [9.5]	0.375 [9.5]	0.375 [9.5]
Face Area sq. ft. [sq. m]	16.23 [1.51]	16.23 [1.51]	16.23 [1.51]	16.23 [1.51]
Rows / FPI [FPcm]	2 / 22 [9]	2 / 22 [9]	2 / 22 [9]	2 / 22 [9]
Indoor Coil—Fin Type	Louvered	Louvered	Louvered	Louvered
Tube Type	Rifled	Rifled	Rifled	Rifled
Tube Size in. [mm]	0.375 [9.5]	0.375 [9.5]	0.375 [9.5]	0.375 [9.5]
Face Area sq. ft. [sq. m]	7.39 [0.69]	7.39 [0.69]	7.39 [0.69]	7.39 [0.69]
Rows / FPI [FPcm]	2 / 15 [6]	2 / 15 [6]	2 / 15 [6]	2 / 15 [6]
Refrigerant Control	TX Valves	TX Valves	TX Valves	TX Valves
Drain Connection No./Size in. [mm]	1/0.75 [19.05]	1/0.75 [19.05]	1/0.75 [19.05]	1/0.75 [19.05]
Outdoor Fan—Type	Propeller	Propeller	Propeller	Propeller
No. Used/Diameter in. [mm]	1/22 [558.8]	1/22 [558.8]	1/22 [558.8]	1/22 [558.8]
Drive Type/No. Speeds	Direct/1	Direct/1	Direct/1	Direct/1
CFM [L/s]	3300 [1557]	3300 [1557]	3300 [1557]	3300 [1557]
No. Motors/HP	1 at 1/3 HP	1 at 1/3 HP	1 at 1/3 HP	1 at 1/3 HP
Motor RPM	1075	1075	1075	1075
Indoor Fan—Type	FC Centrifugal	FC Centrifugal	FC Centrifugal	FC Centrifugal
No. Used/Diameter in. [mm]	1/10x9 [254x229]	1/10x9 [254x229]	1/10x9 [254x229]	1/10x9 [254x229]
Drive Type/No. Speeds	Direct/3	Direct/3	Direct/3	Direct/3
No. Motors	1	1	1	1
Motor HP	3/4	3/4	3/4	3/4
Motor RPM	1075	1075	1075	1075
Motor Frame Size	48	48	48	48
Filter—Type	Field Supplied	Field Supplied	Field Supplied	Field Supplied
Furnished	No	No	No	No
(No.) Size Recommended in. [mm]	(1)1x24x24 [25x610x610]	(1)1x24x24 [25x610x610]	(1)1x24x24 [25x610x610]	(1)1x24x24 [25x610x610]
Refrigerant Charge Oz. [g]	161.2 [4570]	161.2 [4570]	161.2 [4570]	161.2 [4570]
Weights				
Net Weight lbs. [kg]	457 [207]	462 [210]	461 [209]	466 [211]
Ship Weight lbs. [kg]	497 [225]	502 [228]	501 [227]	506 [230]

See Page 28 for Notes.

[] Designates Metric Conversions



NOMINAL SIZES 2-5 TONS [7.0-17.6 kW]

Model RRPL- Series	B048JK10(E/X)	B060CK10	B060JK10(E/X)
Cooling Performance¹			
Gross Cooling Capacity Btu [kW]	50,500 [14.8]	59,500 [17.43]	59,500 [17.43]
EER/SEER ²	12/14	10.8/14	10.8/14
Nominal CFM/AHRI Rated CFM [L/s]	1600/1600 [755/755]	2000/1850 [944/873]	2000/1850 [944/873]
AHRI Net Cooling Capacity Btu [kW]	49,000 [14.36]	57,500 [16.85]	57,500 [16.85]
Net Sensible Capacity Btu [kW]	34,990 [10.25]	40,460 [11.85]	40,460 [11.85]
Net Latent Capacity Btu [kW]	14,010 [4.1]	17,040 [4.99]	17,040 [4.99]
Net System Power [kW]	4.08	5.32	5.32
Heating Performance (Package Gas/Electric)³			
Heating Input Btu [kW]	100,000 [29.3]	100,000 [29.3]	100,000 [29.3]
Heating Output Btu [kW]	77,000 [22.56]	81,000 [23.73]	77,000 [22.56]
Temperature Rise Range °F [°C]	45-85 [25/47.2]	45-85 [25/47.2]	45-85 [25/47.2]
AFUE (%) ⁴	80	80	80
Steady State Efficiency (%)	81	81	81
No. Burners	5	5	5
No. Stages	1	1	1
Gas Connection Pipe Size in. [mm]	0.5 [12.7]	0.5 [12.7]	0.5 [12.7]
Compressor			
No./Type	1/Scroll	1/Scroll	1/Scroll
Outdoor Sound Rating (dB)⁵			
	78	78	78
Outdoor Coil—Fin Type			
Tube Type	Louvered	Louvered	Louvered
Tube Type	Rifled	Rifled	Rifled
Tube Size in. [mm] OD	0.375 [9.5]	0.375 [9.5]	0.375 [9.5]
Face Area sq. ft. [sq. m]	16.23 [1.51]	16.23 [1.51]	16.23 [1.51]
Rows / FPI [FPcm]	2 / 22 [9]	2 / 22 [9]	2 / 22 [9]
Indoor Coil—Fin Type			
Tube Type	Louvered	Louvered	Louvered
Tube Type	Rifled	Rifled	Rifled
Tube Size in. [mm]	0.375 [9.5]	0.375 [9.5]	0.375 [9.5]
Face Area sq. ft. [sq. m]	7.39 [0.69]	7.39 [0.69]	7.39 [0.69]
Rows / FPI [FPcm]	2 / 15 [6]	2 / 15 [6]	2 / 15 [6]
Refrigerant Control	TX Valves	TX Valves	TX Valves
Drain Connection No./Size in. [mm]	1/0.75 [19.05]	1/0.75 [19.05]	1/0.75 [19.05]
Outdoor Fan—Type			
	Propeller	Propeller	Propeller
No. Used/Diameter in. [mm]	1/22 [558.8]	1/22 [558.8]	1/22 [558.8]
Drive Type/No. Speeds	Direct/1	Direct/1	Direct/1
CFM [L/s]	3300 [1557]	3300 [1557]	3300 [1557]
No. Motors/HP	1 at 1/3 HP	1 at 1/3 HP	1 at 1/3 HP
Motor RPM	1075	1075	1075
Indoor Fan—Type			
	FC Centrifugal	FC Centrifugal	FC Centrifugal
No. Used/Diameter in. [mm]	1/10x9 [254x229]	1/12x9 [305x229]	1/12x9 [305x229]
Drive Type/No. Speeds	Direct/3	Direct/3	Direct/3
No. Motors	1	1	1
Motor HP	3/4	1	1
Motor RPM	1075	1075	1075
Motor Frame Size	48	48	48
Filter—Type			
Furnished	Field Supplied	Field Supplied	Field Supplied
	No	No	No
(No.) Size Recommended in. [mm]	(1)1x24x24 [25x610x610]	(1)1x24x30 [25x610x762]	(1)1x24x30 [25x610x762]
Refrigerant Charge Oz. [g]			
	161.2 [4570]	172.8 [4899]	172.8 [4899]
Weights			
Net Weight lbs. [kg]	471 [214]	532 [241]	532 [241]
Ship Weight lbs. [kg]	511 [232]	577 [262]	577 [262]

See Page 28 for Notes.

[] Designates Metric Conversions



NOMINAL SIZES 2-5 TONS [7.0-17.6 kW]

Model RRRL- Series	C024JK06(E/X)	C036CK06	C036CK08	C036CK10
Cooling Performance¹				CONTINUED →
Gross Cooling Capacity (2nd Stage) Btu [kW]	24,200 [7.09]	36,800 [10.78]	36,800 [10.78]	36,800 [10.78]
SEER ²	16.1	16.3	16.3	16.3
EER (1st stage / 2nd stage)	13.5/12.4	13.4/12.3	13.4/12.3	13.4/12.3
AHRI Rated CFM (1st / 2nd stage) [L/s]	550/800 [260/378]	800/1200 [378/566]	800/1200 [378/566]	800/1200 [378/566]
AHRI Net Cooling Capacity (1st / 2nd stage) Btu [kW]	18,500/23,800 [5.42/6.97]	25,000/36,000 [7.32/10.55]	25,000/36,000 [7.32/10.55]	25,000/36,000 [7.32/10.55]
Net Sensible Capacity (1st / 2nd stage) Btu [kW]	13,380/17,410 [3.92/5.1]	18,470/27,280 [5.41/7.99]	18,470/27,280 [5.41/7.99]	18,470/27,280 [5.41/7.99]
Net Latent Capacity (1st / 2nd stage) Btu [kW]	5,120/6,390 [1.5/1.87]	6,530/8,720 [1.91/2.55]	6,530/8,720 [1.91/2.55]	6,530/8,720 [1.91/2.55]
Net System Power (1st / 2nd stage) [kW]	1.37/1.92	1.87/2.94	1.87/2.94	1.87/2.94
Heating Performance (Gas)³				
Heating Input Btu [kW] (1st / 2nd stage)	42,000/60,000 [12.31/17.58]	42,000/60,000 [12.31/17.58]	56,000/80,000 [16.41/23.44]	70,000/100,000 [20.51/29.3]
Heating Output Btu [kW] (1st / 2nd stage)	33,600/48,000 [9.84/14.06]	34,020/48,600 [9.97/14.24]	45,360/64,800 [13.29/18.99]	56,700/81,000 [16.61/23.73]
Temperature Rise Range °F [°C] (1st / 2nd stage)	25-55 [13.9-30.6] / 40-70 [22.2-38.9]	15-45 [8.3-25] / 30-60 [16.7-33.3]	20-50 [11.1-27.8] / 40-70 [22.2-38.9]	35-65 [19.4-36.1] / 55-85 [30.6-47.2]
AFUE (%) ⁴	80	80	80	80
Steady State Efficiency (%)	81	81	81	81
No. Burners	3	3	4	5
No. Stages	2	2	2	2
Gas Connection Pipe Size in. [mm]	0.5 [12.7]	0.5 [12.7]	0.5 [12.7]	0.5 [12.7]
Compressor				
No./Type	1/Scroll	1/Scroll	1/Scroll	1/Scroll
Outdoor Sound Rating (dB)⁵	76	76	76	76
Outdoor Coil—Fin Type	Louvered	Louvered	Louvered	Louvered
Tube Type	Rifled	Rifled	Rifled	Rifled
Tube Size in. [mm] OD	0.375 [9.5]	0.375 [9.5]	0.375 [9.5]	0.375 [9.5]
Face Area sq. ft. [sq. m]	10.56 [0.98]	16.23 [1.51]	16.23 [1.51]	16.23 [1.51]
Rows / FPI [FPcm]	1 / 18 [7]	2 / 22 [9]	2 / 22 [9]	2 / 22 [9]
Indoor Coil—Fin Type	Louvered	Louvered	Louvered	Louvered
Tube Type	Rifled	Rifled	Rifled	Rifled
Tube Size in. [mm]	0.375 [9.5]	0.375 [9.5]	0.375 [9.5]	0.375 [9.5]
Face Area sq. ft. [sq. m]	5.54 [0.51]	7.39 [0.69]	7.39 [0.69]	7.39 [0.69]
Rows / FPI [FPcm]	2 / 15 [6]	2 / 15 [6]	2 / 15 [6]	2 / 15 [6]
Refrigerant Control	TX Valves	TX Valves	TX Valves	TX Valves
Drain Connection No./Size in. [mm]	1/0.75 [19.05]	1/0.75 [19.05]	1/0.75 [19.05]	1/0.75 [19.05]
Outdoor Fan—Type	Propeller	Propeller	Propeller	Propeller
No. Used/Diameter in. [mm]	1/22 [558.8]	1/22 [558.8]	1/22 [558.8]	1/22 [558.8]
Drive Type/No. Speeds	Direct/1	Direct/1	Direct/1	Direct/1
CFM [L/s]	2500 [1180]	2700 [1274]	2700 [1274]	2700 [1274]
No. Motors/HP	1 at 1/6 HP	1 at 1/6 HP	1 at 1/6 HP	1 at 1/6 HP
Motor RPM	850	850	850	850
Indoor Fan—Type	FC Centrifugal	FC Centrifugal	FC Centrifugal	FC Centrifugal
No. Used/Diameter in. [mm]	1/9x7 [229x178]	1/10x9 [254x229]	1/10x9 [254x229]	1/10x9 [254x229]
Drive Type/No. Speeds	Direct/11	Direct/11	Direct/11	Direct/11
No. Motors	1	1	1	1
Motor HP	1/3	1/2	1/2	1/2
Motor RPM	1050	1050	1050	1050
Motor Frame Size	48	48	48	48
Filter—Type	Field Supplied	Field Supplied	Field Supplied	Field Supplied
Furnished	No	No	No	No
(NO.) Size Recommended in. [mm x mm x mm]	(1)1x20x20 [25x508x508]	(1)1x24x24 [25x610x610]	(1)1x24x24 [25x610x610]	(1)1x24x24 [25x610x610]
Refrigerant Charge Oz. [g]	97.6 [2767]	155.2 [4400]	155.2 [4400]	155.2 [4400]
Weights				
Net Weight lbs. [kg]	454 [206]	544 [247]	549 [249]	554 [251]
Ship Weight lbs. [kg]	467 [212]	558 [253]	558 [253]	558 [253]

See Page 28 for Notes.

[] Designates Metric Conversions



NOMINAL SIZES 2-5 TONS [7.0-17.6 kW]

Model RRRL- Series	C036JK06(E/X)	C036JK08(E/X)	C036JK10(E/X)	C048CK08
Cooling Performance¹				CONTINUED →
Gross Cooling Capacity (2nd Stage) Btu [kW]	36,800 [10.78]	36,800 [10.78]	36,800 [10.78]	48,500 [14.21]
SEER ²	16.3	16.3	16.3	15
EER (1st stage / 2nd stage)	13.4/12.3	13.4/12.3	13.4/12.3	12.7/11.5
AHRI Rated CFM (1st / 2nd stage) [L/s]	800/1200 [378/566]	800/1200 [378/566]	800/1200 [378/566]	1050/1600 [495/755]
AHRI Net Cooling Capacity (1st / 2nd stage) Btu [kW]	25,000/36,000 [7.32/10.55]	25,000/36,000 [7.32/10.55]	25,000/36,000 [7.32/10.55]	34,800/47,000 [10.2/13.77]
Net Sensible Capacity (1st / 2nd stage) Btu [kW]	18,470/27,280 [5.41/7.99]	18,470/27,280 [5.41/7.99]	18,470/27,280 [5.41/7.99]	24,820/34,480 [7.27/10.1]
Net Latent Capacity (1st / 2nd stage) Btu [kW]	6,530/8,720 [1.91/2.55]	6,530/8,720 [1.91/2.55]	6,530/8,720 [1.91/2.55]	9,980/12,520 [2.92/3.67]
Net System Power (1st / 2nd stage) [kW]	1.87/2.94	1.87/2.94	1.87/2.94	2.73/4.1
Heating Performance (Gas)³				
Heating Input Btu [kW] (1st / 2nd stage)	42,000/60,000 [12.31/17.58]	56,000/80,000 [16.41/23.44]	70,000/100,000 [20.51/29.3]	56,000/80,000 [16.41/23.44]
Heating Output Btu [kW] (1st / 2nd stage)	33,600/48,000 [9.84/14.06]	44,800/64,000 [13.13/18.75]	56,000/80,000 [16.41/23.44]	45,360/64,800 [13.29/18.99]
Temperature Rise Range °F [°C] (1st / 2nd stage)	15-45 [8.3-25] / 30-60 [16.7-33.3]	20-50 [11.1-27.8] / 40-70 [22.2-38.9]	35-65 [19.4-36.1] / 55-85 [30.6-47.2]	20-50 [11.1-27.8] / 40-70 [22.2-38.9]
AFUE (%) ⁴	80	80	80	80
Steady State Efficiency (%)	81	81	81	81
No. Burners	3	4	5	4
No. Stages	2	2	2	2
Gas Connection Pipe Size in. [mm]	0.5 [12.7]	0.5 [12.7]	0.5 [12.7]	0.5 [12.7]
Compressor				
No./Type	1/Scroll	1/Scroll	1/Scroll	1/Scroll
Outdoor Sound Rating (dB)⁵	76	76	76	78
Outdoor Coil—Fin Type	Louvered	Louvered	Louvered	Louvered
Tube Type	Rifled	Rifled	Rifled	Rifled
Tube Size in. [mm] OD	0.375 [9.5]	0.375 [9.5]	0.375 [9.5]	0.375 [9.5]
Face Area sq. ft. [sq. m]	16.23 [1.51]	16.23 [1.51]	16.23 [1.51]	16.23 [1.51]
Rows / FPI [FPcm]	2 / 22 [9]	2 / 22 [9]	2 / 22 [9]	2 / 22 [9]
Indoor Coil—Fin Type	Louvered	Louvered	Louvered	Louvered
Tube Type	Rifled	Rifled	Rifled	Rifled
Tube Size in. [mm]	0.375 [9.5]	0.375 [9.5]	0.375 [9.5]	0.375 [9.5]
Face Area sq. ft. [sq. m]	7.39 [0.69]	7.39 [0.69]	7.39 [0.69]	7.39 [0.69]
Rows / FPI [FPcm]	2 / 15 [6]	2 / 15 [6]	2 / 15 [6]	2 / 15 [6]
Refrigerant Control	TX Valves	TX Valves	TX Valves	TX Valves
Drain Connection No./Size in. [mm]	1/0.75 [19.05]	1/0.75 [19.05]	1/0.75 [19.05]	1/0.75 [19.05]
Outdoor Fan—Type	Propeller	Propeller	Propeller	Propeller
No. Used/Diameter in. [mm]	1/22 [558.8]	1/22 [558.8]	1/22 [558.8]	1/22 [558.8]
Drive Type/No. Speeds	Direct/1	Direct/1	Direct/1	Direct/1
CFM [L/s]	2700 [1274]	2700 [1274]	2700 [1274]	3300 [1557]
No. Motors/HP	1 at 1/6 HP	1 at 1/6 HP	1 at 1/6 HP	1 at 1/3 HP
Motor RPM	850	850	850	850
Indoor Fan—Type	FC Centrifugal	FC Centrifugal	FC Centrifugal	FC Centrifugal
No. Used/Diameter in. [mm]	1/10x9 [254x229]	1/10x9 [254x229]	1/10x9 [254x229]	1/10x9 [254x229]
Drive Type/No. Speeds	Direct/11	Direct/11	Direct/11	Direct/11
No. Motors	1	1	1	1
Motor HP	1/2	1/2	1/2	3/4
Motor RPM	1050	1050	1050	1050
Motor Frame Size	48	48	48	48
Filter—Type	Field Supplied	Field Supplied	Field Supplied	Field Supplied
Furnished	No	No	No	No
(NO.) Size Recommended in. [mm x mm x mm]	(1)1x24x24 [25x610x610]	(1)1x24x24 [25x610x610]	(1)1x24x24 [25x610x610]	(1)1x24x24 [25x610x610]
Refrigerant Charge Oz. [g]	155.2 [4400]	155.2 [4400]	155.2 [4400]	169.6 [4808]
Weights				
Net Weight lbs. [kg]	552 [250]	557 [253]	557 [253]	549 [249]
Ship Weight lbs. [kg]	558 [253]	558 [253]	558 [253]	562 [255]

See Page 28 for Notes.

[] Designates Metric Conversions



NOMINAL SIZES 2-5 TONS [7.0-17.6 kW]

Model RRRL- Series	C048CK10	C048JK08(E/X)	C048JK10(E/X)	C060CK10
Cooling Performance¹				CONTINUED →
Gross Cooling Capacity (2nd Stage) Btu [kW]	48,500 [14.21]	48,500 [14.21]	48,500 [14.21]	60,500 [17.73]
SEER ²	15	15	15	14.2
EER (1st stage / 2nd stage)	12.7/11.5	12.7/11.5	12.7/11.5	12/10.7
AHRI Rated CFM (1st / 2nd stage) [L/s]	1050/1600 [495/755]	1050/1600 [495/755]	1050/1600 [495/755]	1250/1850 [590/873]
AHRI Net Cooling Capacity (1st / 2nd stage) Btu [kW]	34,800/47,000 [10.2/13.77]	34,800/47,000 [10.2/13.77]	34,800/47,000 [10.2/13.77]	41,800/58,000 [12.25/16.99]
Net Sensible Capacity (1st / 2nd stage) Btu [kW]	24,820/34,480 [7.27/10.1]	24,820/34,480 [7.27/10.1]	24,820/34,480 [7.27/10.1]	30,000/42,280 [8.79/12.39]
Net Latent Capacity (1st / 2nd stage) Btu [kW]	9,980/12,520 [2.92/3.67]	9,980/12,520 [2.92/3.67]	9,980/12,520 [2.92/3.67]	11,800/15,720 [3.46/4.61]
Net System Power (1st / 2nd stage) [kW]	2.73/4.1	2.73/4.1	2.73/4.1	3.48/5.4
Heating Performance (Gas)³				
Heating Input Btu [kW] (1st / 2nd stage)	70,000/100,000 [20.51/29.3]	56,000/80,000 [16.41/23.44]	70,000/100,000 [20.51/29.3]	70,000/100,000 [20.51/29.3]
Heating Output Btu [kW] (1st / 2nd stage)	56,700/81,000 [16.61/23.73]	44,800/64,000 [13.13/18.75]	56,000/80,000 [16.41/23.44]	56,700/81,000 [16.61/23.73]
Temperature Rise Range °F [°C] (1st / 2nd stage)	35-65 [19.4-36.1] / 55-85 [30.6-47.2]	20-50 [11.1-27.8] / 40-70 [22.2-38.9]	35-65 [19.4-36.1] / 55-85 [30.6-47.2]	30-60 [16.7-33.3] / 45-75 [25-41.7]
AFUE (%) ⁴	0	80	80	0
Steady State Efficiency (%)	81	81	81	81
No. Burners	5	4	5	5
No. Stages	2	2	2	2
Gas Connection Pipe Size in. [mm]	0.5 [12.7]	0.5 [12.7]	0.5 [12.7]	0.5 [12.7]
Compressor				
No./Type	1/Scroll	1/Scroll	1/Scroll	1/Scroll
Outdoor Sound Rating (dB)⁵	78	78	78	78
Outdoor Coil—Fin Type	Louvered	Louvered	Louvered	Louvered
Tube Type	Rifled	Rifled	Rifled	Rifled
Tube Size in. [mm] OD	0.375 [9.5]	0.375 [9.5]	0.375 [9.5]	0.375 [9.5]
Face Area sq. ft. [sq. m]	16.23 [1.51]	16.23 [1.51]	16.23 [1.51]	16.23 [1.51]
Rows / FPI [FPcm]	2 / 22 [9]	2 / 22 [9]	2 / 22 [9]	2 / 22 [9]
Indoor Coil—Fin Type	Louvered	Louvered	Louvered	Louvered
Tube Type	Rifled	Rifled	Rifled	Rifled
Tube Size in. [mm]	0.375 [9.5]	0.375 [9.5]	0.375 [9.5]	0.375 [9.5]
Face Area sq. ft. [sq. m]	7.39 [0.69]	7.39 [0.69]	7.39 [0.69]	7.39 [0.69]
Rows / FPI [FPcm]	2 / 15 [6]	2 / 15 [6]	2 / 15 [6]	2 / 15 [6]
Refrigerant Control	TX Valves	TX Valves	TX Valves	TX Valves
Drain Connection No./Size in. [mm]	1/0.75 [19.05]	1/0.75 [19.05]	1/0.75 [19.05]	1/0.75 [19.05]
Outdoor Fan—Type	Propeller	Propeller	Propeller	Propeller
No. Used/Diameter in. [mm]	1/22 [558.8]	1/22 [558.8]	1/22 [558.8]	1/22 [558.8]
Drive Type/No. Speeds	Direct/1	Direct/1	Direct/1	Direct/1
CFM [L/s]	3300 [1557]	3300 [1557]	3300 [1557]	3300 [1557]
No. Motors/HP	1 at 1/3 HP	1 at 1/3 HP	1 at 1/3 HP	1 at 1/3 HP
Motor RPM	850	850	850	1075
Indoor Fan—Type	FC Centrifugal	FC Centrifugal	FC Centrifugal	FC Centrifugal
No. Used/Diameter in. [mm]	1/10x9 [254x229]	1/10x9 [254x229]	1/10x9 [254x229]	1/12x9 [305x229]
Drive Type/No. Speeds	Direct/11	Direct/11	Direct/11	Direct/11
No. Motors	1	1	1	1
Motor HP	3/4	3/4	3/4	1
Motor RPM	1050	1050	1050	1050
Motor Frame Size	48	48	48	48
Filter—Type	Field Supplied	Field Supplied	Field Supplied	Field Supplied
Furnished	No	No	No	No
(NO.) Size Recommended in. [mm x mm x mm]	(1)1x24x24 [25x610x610]	(1)1x24x24 [25x610x610]	(1)1x24x24 [25x610x610]	(1)1x24x30 [25x610x762]
Refrigerant Charge Oz. [g]	169.6 [4808]	169.6 [4808]	169.6 [4808]	165.8 [4700]
Weights				
Net Weight lbs. [kg]	554 [251]	557 [253]	562 [255]	571 [259]
Ship Weight lbs. [kg]	562 [255]	562 [255]	562 [255]	594 [269]

See Page 28 for Notes.

[] Designates Metric Conversions

**NOMINAL SIZES 2-5 TONS [7.0-17.6 kW]**

Model RRRL- Series	C060JK10(E/X)
Cooling Performance¹	
Gross Cooling Capacity (2nd Stage) Btu [kW]	60,500 [17.73]
SEER ²	14.2
EER (1st stage / 2nd stage)	12/10.7
AHRI Rated CFM (1st / 2nd stage) [L/s]	1250/1850 [590/873]
AHRI Net Cooling Capacity (1st / 2nd stage) Btu [kW]	41,800/58,000 [12.25/16.99]
Net Sensible Capacity (1st / 2nd stage) Btu [kW]	30,000/42,280 [8.79/12.39]
Net Latent Capacity (1st / 2nd stage) Btu [kW]	11,800/15,720 [3.46/4.61]
Net System Power (1st / 2nd stage) [kW]	3.48/5.4
Heating Performance (Gas)³	
Heating Input Btu [kW] (1st / 2nd stage)	70,000/100,000 [20.51/29.3]
Heating Output Btu [kW] (1st / 2nd stage)	56,000/80,000 [16.41/23.44]
Temperature Rise Range °F [°C] (1st / 2nd stage)	30-60 [16.7-33.3] / 45-75 [25-41.7]
AFUE (%) ⁴	80
Steady State Efficiency (%)	81
No. Burners	5
No. Stages	2
Gas Connection Pipe Size in. [mm]	0.5 [12.7]
Compressor	
No./Type	1/Scroll
Outdoor Sound Rating (dB)⁵	
	78
Outdoor Coil—Fin Type	
Tube Type	Louvered
Tube Type	Rifled
Tube Size in. [mm] OD	0.375 [9.5]
Face Area sq. ft. [sq. m]	16.23 [1.51]
Rows / FPI [FPcm]	2 / 22 [9]
Indoor Coil—Fin Type	
Tube Type	Louvered
Tube Type	Rifled
Tube Size in. [mm]	0.375 [9.5]
Face Area sq. ft. [sq. m]	7.39 [0.69]
Rows / FPI [FPcm]	2 / 15 [6]
Refrigerant Control	TX Valves
Drain Connection No./Size in. [mm]	1/0.75 [19.05]
Outdoor Fan—Type	
	Propeller
No. Used/Diameter in. [mm]	1/22 [558.8]
Drive Type/No. Speeds	Direct/1
CFM [L/s]	3300 [1557]
No. Motors/HP	1 at 1/3 HP
Motor RPM	1075
Indoor Fan—Type	
	FC Centrifugal
No. Used/Diameter in. [mm]	1/12x9 [305x229]
Drive Type/No. Speeds	Direct/11
No. Motors	1
Motor HP	1
Motor RPM	1050
Motor Frame Size	48
Filter—Type	
	Field Supplied
Furnished	No
(NO.) Size Recommended in. [mm x mm x mm]	(1)1x24x30 [25x610x762]
Refrigerant Charge Oz. [g]	
	165.8 [4700]
Weights	
Net Weight lbs. [kg]	583 [264]
Ship Weight lbs. [kg]	594 [269]

See Page 28 for Notes.

[] Designates Metric Conversions



NOTES:

1. Cooling Performance is rated at 95° F ambient, 80° F entering dry bulb, 67° F entering wet bulb. Gross capacity does not include the effect of fan motor heat. AHRI capacity is net and includes the effect of fan motor heat. Units are suitable for operation in CFM range shown in airflow tables. Units are certified in accordance with the Unitary Air Conditioner Equipment certification program, which is based on AHRI Standard 210/240 or 360.
2. EER and/or SEER are rated at AHRI conditions and in accordance with DOE test procedures.
3. Heating Performance limit settings and rating data were established and approved under laboratory test conditions using American National Standard Institute standards. Ratings shown are for elevations up to 2000 feet. For elevations above 2000 feet, ratings should be reduced at the rate of 4% for each 1000 feet above sea level.
4. AFUE is rated in accordance with DOE test procedures.
5. Outdoor Sound Rating shown is tested in accordance with AHRI Standard 270.



SYSTEMS PERFORMANCE—RRNL- SERIES

GROSS SYSTEMS PERFORMANCE DATA—B024

		ENTERING INDOOR AIR @ 80°F [26.7°C] dbE ①									
wbE		71°F [21.7°C]			67°F [19.4°C]			63°F [17.2°C]			
CFM [L/s]		880 [415]	800 [378]	680 [321]	880 [415]	800 [378]	680 [321]	880 [415]	800 [378]	680 [321]	
DR ①		.19	.17	.16	.19	.17	.16	.19	.17	.16	
OUTDOOR DRY BULB TEMPERATURE °F [°C]	75 [23.9]	Total BTUH [kW] Sens BTUH [kW] Power	29.6 [8.67] 17.6 [5.16] 1.5	29.0 [8.50] 16.8 [4.92] 1.5	28.5 [8.35] 16.0 [4.69] 1.5	27.8 [8.15] 20.7 [6.07] 1.5	27.3 [8.00] 19.8 [5.80] 1.5	26.8 [7.85] 18.8 [5.51] 1.5	26.6 [7.80] 22.1 [6.48] 1.5	26.1 [7.65] 21.2 [6.21] 1.5	25.7 [7.53] 20.2 [5.92] 1.5
	80 [26.7]	Total BTUH [kW] Sens BTUH [kW] Power	29.0 [8.50] 17.3 [5.07] 1.6	28.5 [8.35] 16.5 [4.84] 1.6	28.0 [8.21] 15.7 [4.60] 1.6	27.2 [7.97] 20.3 [5.95] 1.6	26.8 [7.85] 19.4 [5.69] 1.6	26.3 [7.71] 18.5 [5.42] 1.6	26.0 [7.62] 21.8 [6.39] 1.6	25.6 [7.50] 20.8 [6.10] 1.6	25.1 [7.36] 19.9 [5.83] 1.6
	85 [29.4]	Total BTUH [kW] Sens BTUH [kW] Power	28.3 [8.29] 16.9 [4.95] 1.7	27.8 [8.15] 16.1 [4.72] 1.7	27.3 [8.00] 15.4 [4.51] 1.7	26.5 [7.77] 19.9 [5.83] 1.7	26.1 [7.65] 19.0 [5.57] 1.7	25.6 [7.50] 18.1 [5.30] 1.7	25.3 [7.41] 21.4 [6.27] 1.7	24.9 [7.30] 20.4 [5.98] 1.7	24.4 [7.15] 19.5 [5.71] 1.7
	90 [32.2]	Total BTUH [kW] Sens BTUH [kW] Power	27.5 [8.06] 16.4 [4.81] 1.8	27.0 [7.91] 15.7 [4.60] 1.8	26.5 [7.77] 14.9 [4.37] 1.8	25.7 [7.53] 19.5 [5.71] 1.8	25.3 [7.41] 18.6 [5.45] 1.8	24.8 [7.27] 17.7 [5.19] 1.8	24.5 [7.18] 20.9 [6.13] 1.8	24.1 [7.06] 20.0 [5.86] 1.8	23.7 [6.95] 19.1 [5.60] 1.8
	95 [35]	Total BTUH [kW] Sens BTUH [kW] Power	26.6 [7.80] 15.9 [4.66] 1.9	26.1 [7.65] 15.2 [4.45] 1.9	25.7 [7.53] 14.5 [4.25] 1.9	24.9 [7.30] 19.0 [5.57] 1.9	24.4 [7.15] 18.2 [5.33] 1.9	24.0 [7.03] 17.3 [5.07] 1.9	23.7 [6.95] 20.5 [6.01] 1.9	23.2 [6.80] 19.6 [5.74] 1.9	22.8 [6.68] 18.6 [5.45] 1.9
	100 [37.8]	Total BTUH [kW] Sens BTUH [kW] Power	25.7 [7.53] 15.5 [4.54] 2.0	25.3 [7.41] 14.8 [4.34] 2.0	24.8 [7.27] 14.1 [4.13] 2.0	24.0 [7.03] 18.6 [5.45] 2.0	23.5 [6.89] 17.8 [5.22] 2.0	23.1 [6.77] 16.9 [4.95] 2.0	22.8 [6.68] 20.0 [5.86] 2.0	22.4 [6.56] 19.2 [5.63] 2.0	22.0 [6.45] 18.3 [5.36] 2.0
	105 [40.6]	Total BTUH [kW] Sens BTUH [kW] Power	24.9 [7.30] 15.1 [4.43] 2.1	24.4 [7.15] 14.5 [4.25] 2.1	24.0 [7.03] 13.8 [4.04] 2.1	23.1 [6.77] 18.2 [5.33] 2.1	22.7 [6.65] 17.4 [5.10] 2.1	22.3 [6.54] 16.6 [4.86] 2.1	21.9 [6.42] 19.7 [5.77] 2.1	21.5 [6.30] 18.8 [5.51] 2.1	21.1 [6.18] 17.9 [5.25] 2.1
	110 [43.3]	Total BTUH [kW] Sens BTUH [kW] Power	24.0 [7.03] 14.9 [4.37] 2.2	23.6 [6.92] 14.2 [4.16] 2.2	23.2 [6.80] 13.6 [3.99] 2.1	22.3 [6.54] 18.0 [5.28] 2.2	21.9 [6.42] 17.2 [5.04] 2.2	21.5 [6.30] 16.4 [4.81] 2.1	21.1 [6.18] 19.4 [5.69] 2.2	20.7 [6.07] 18.6 [5.45] 2.2	20.3 [5.95] 17.7 [5.19] 2.1
	115 [46.1]	Total BTUH [kW] Sens BTUH [kW] Power	23.3 [6.83] 14.8 [4.34] 2.3	22.9 [6.71] 14.1 [4.13] 2.3	22.4 [6.56] 13.4 [3.93] 2.2	21.5 [6.30] 17.8 [5.22] 2.3	21.1 [6.18] 17.0 [4.98] 2.3	20.8 [6.10] 16.2 [4.75] 2.2	20.3 [5.95] 19.3 [5.66] 2.3	20.0 [5.86] 18.4 [5.39] 2.3	19.6 [5.74] 17.6 [5.16] 2.2

GROSS SYSTEMS PERFORMANCE DATA—B030

		ENTERING INDOOR AIR @ 80°F [26.7°C] dbE ①									
wbE		71°F [21.7°C]			67°F [19.4°C]			63°F [17.2°C]			
CFM [L/s]		1100 [519]	1000 [472]	850 [401]	1100 [519]	1000 [472]	850 [401]	1100 [519]	1000 [472]	850 [401]	
DR ①		.22	.20	.19	.22	.20	.19	.22	.20	.19	
OUTDOOR DRY BULB TEMPERATURE °F [°C]	75 [23.9]	Total BTUH [kW] Sens BTUH [kW] Power	36.7 [10.76] 21.3 [6.24] 1.8	36.0 [10.55] 20.4 [5.98] 1.8	35.4 [10.37] 19.4 [5.69] 1.8	34.5 [10.11] 25.4 [7.44] 1.8	33.9 [9.94] 24.3 [7.12] 1.8	33.3 [9.76] 23.2 [6.80] 1.8	33.1 [9.70] 27.1 [7.94] 1.8	32.6 [9.55] 25.9 [7.59] 1.8	32.0 [9.38] 24.7 [7.24] 1.8
	80 [26.7]	Total BTUH [kW] Sens BTUH [kW] Power	35.8 [10.49] 20.7 [6.07] 1.9	35.2 [10.32] 19.8 [5.80] 1.9	34.5 [10.11] 18.9 [5.54] 1.9	33.6 [9.85] 24.8 [7.27] 1.9	33.0 [9.67] 23.7 [6.95] 1.9	32.4 [9.50] 22.6 [6.62] 1.9	32.2 [9.44] 26.5 [7.77] 1.9	31.7 [9.29] 25.3 [7.41] 1.9	31.1 [9.11] 24.1 [7.06] 1.9
	85 [29.4]	Total BTUH [kW] Sens BTUH [kW] Power	34.8 [10.20] 20.1 [5.89] 2.0	34.2 [10.02] 19.2 [5.63] 2.0	33.5 [9.82] 18.3 [5.36] 2.0	32.6 [9.55] 24.2 [7.09] 2.0	32.0 [9.38] 23.1 [6.77] 2.0	31.4 [9.20] 22.0 [6.45] 2.0	31.2 [9.14] 25.9 [7.59] 2.0	30.7 [9.00] 24.7 [7.24] 2.0	30.1 [8.82] 23.6 [6.92] 2.0
	90 [32.2]	Total BTUH [kW] Sens BTUH [kW] Power	33.7 [9.88] 19.5 [5.71] 2.2	33.1 [9.70] 18.6 [5.45] 2.1	32.5 [9.52] 17.7 [5.19] 2.1	31.5 [9.23] 23.6 [6.92] 2.2	30.9 [9.06] 22.5 [6.59] 2.1	30.3 [8.88] 21.5 [6.30] 2.1	30.1 [8.82] 25.2 [7.39] 2.1	29.6 [8.67] 24.1 [7.06] 2.1	29.0 [8.50] 23.0 [6.74] 2.1
	95 [35]	Total BTUH [kW] Sens BTUH [kW] Power	32.5 [9.52] 18.8 [5.51] 2.3	31.9 [9.35] 18.0 [5.28] 2.2	31.3 [9.17] 17.2 [5.04] 2.2	30.3 [8.88] 23.0 [6.74] 2.3	29.7 [8.70] 21.9 [6.42] 2.2	29.2 [8.56] 20.9 [6.13] 2.2	28.9 [8.47] 24.6 [7.21] 2.3	28.4 [8.32] 23.5 [6.89] 2.2	27.9 [8.18] 22.4 [6.56] 2.2
	100 [37.8]	Total BTUH [kW] Sens BTUH [kW] Power	31.2 [9.14] 18.2 [5.33] 2.4	30.6 [8.97] 17.4 [5.10] 2.4	30.1 [8.82] 16.6 [4.86] 2.3	29.0 [8.50] 22.3 [6.54] 2.4	28.5 [8.35] 21.3 [6.24] 2.4	28.0 [8.21] 20.3 [5.95] 2.3	27.7 [8.12] 24.0 [7.03] 2.4	27.2 [7.97] 22.9 [6.71] 2.4	26.7 [7.83] 21.8 [6.39] 2.3
	105 [40.6]	Total BTUH [kW] Sens BTUH [kW] Power	29.9 [8.76] 17.5 [5.13] 2.5	29.4 [8.62] 16.7 [4.89] 2.5	28.8 [8.44] 16.0 [4.69] 2.5	27.7 [8.12] 21.6 [6.33] 2.5	27.2 [7.97] 20.7 [6.07] 2.5	26.7 [7.83] 19.7 [5.77] 2.5	26.3 [7.71] 23.3 [6.83] 2.5	25.9 [7.59] 22.3 [6.54] 2.5	25.4 [7.44] 21.2 [6.21] 2.4
	110 [43.3]	Total BTUH [kW] Sens BTUH [kW] Power	28.5 [8.35] 16.8 [4.92] 2.6	28.0 [8.21] 16.0 [4.69] 2.6	27.5 [8.06] 15.3 [4.48] 2.6	26.3 [7.71] 20.9 [6.13] 2.6	25.9 [7.59] 20.0 [5.86] 2.6	25.4 [7.44] 19.0 [5.57] 2.6	25.0 [7.33] 22.6 [6.62] 2.6	24.5 [7.18] 21.6 [6.33] 2.6	24.1 [7.06] 20.6 [6.04] 2.6
	115 [46.1]	Total BTUH [kW] Sens BTUH [kW] Power	27.2 [7.97] 16.0 [4.69] 2.7	26.7 [7.83] 15.3 [4.48] 2.7	26.2 [7.68] 14.6 [4.28] 2.7	25.0 [7.33] 20.1 [5.89] 2.7	24.5 [7.18] 19.2 [5.63] 2.7	24.1 [7.06] 18.3 [5.36] 2.7	23.6 [6.92] 21.8 [6.39] 2.7	23.2 [6.80] 20.8 [6.10] 2.7	22.8 [6.68] 19.8 [5.80] 2.7

DR —Depression ratio
dbE—Entering air dry bulb
wbE—Entering air wet bulb

Total —Total capacity x 1000 BTUH
Sens —Sensible capacity x 1000 BTUH
Power—KW input

NOTES: ① When the entering air dry bulb is other than 80°F [27°C], adjust the sensible capacity from the table by adding [1.10 x CFM x (1 - DR) x (dbE - 80)].

[] Designates Metric Conversions



GROSS SYSTEMS PERFORMANCE DATA—B036

		ENTERING INDOOR AIR @ 80°F [26.7°C] dbE ①									
wbE		71°F [21.7°C]			67°F [19.4°C]			63°F [17.2°C]			
CFM [L/s]		1320 [623]	1200 [566]	1080 [510]	1320 [623]	1200 [566]	1080 [510]	1320 [623]	1200 [566]	1080 [510]	
DR ①		.17	.15	.13	.17	.15	.13	.17	.15	.13	
OUTDOOR DRY BULB TEMPERATURE °F [°C]	75 [23.9]	Total BTUH [kW] Sens BTUH [kW] Power	44.9 [13.16] 26.5 [7.77] 2.3	44.1 [12.92] 25.3 [7.41] 2.2	43.3 [12.69] 24.1 [7.06] 2.2	42.3 [12.40] 31.6 [9.26] 2.2	41.5 [12.16] 30.2 [8.85] 2.2	40.7 [11.93] 28.8 [8.44] 2.2	40.6 [11.90] 33.5 [9.82] 2.2	39.9 [11.69] 32.0 [9.38] 2.2	39.2 [11.49] 30.5 [8.94] 2.2
	80 [26.7]	Total BTUH [kW] Sens BTUH [kW] Power	44.2 [12.95] 26.2 [7.68] 2.4	43.4 [12.72] 25.0 [7.33] 2.4	42.6 [12.48] 23.8 [6.98] 2.4	41.6 [12.19] 31.3 [9.17] 2.4	40.8 [11.96] 29.9 [8.76] 2.4	40.1 [11.75] 28.5 [8.35] 2.3	39.9 [11.69] 33.2 [9.73] 2.4	39.2 [11.49] 31.7 [9.29] 2.4	38.5 [11.28] 30.2 [8.85] 2.3
	85 [29.4]	Total BTUH [kW] Sens BTUH [kW] Power	43.1 [12.63] 25.6 [7.50] 2.5	42.4 [12.43] 24.4 [7.15] 2.5	41.6 [12.19] 23.3 [6.83] 2.5	40.5 [11.87] 30.7 [9.00] 2.5	39.8 [11.66] 29.3 [8.59] 2.5	39.1 [11.46] 27.9 [8.18] 2.5	38.9 [11.40] 32.6 [9.55] 2.5	38.2 [11.20] 31.1 [9.11] 2.5	37.5 [10.99] 29.7 [8.70] 2.5
	90 [32.2]	Total BTUH [kW] Sens BTUH [kW] Power	41.8 [12.25] 24.8 [7.27] 2.7	41.1 [12.05] 23.7 [6.95] 2.7	40.3 [11.81] 22.6 [6.62] 2.6	39.2 [11.49] 29.9 [8.76] 2.7	38.5 [11.28] 28.6 [8.38] 2.6	37.8 [11.08] 27.3 [8.00] 2.6	37.6 [11.02] 31.8 [9.32] 2.7	36.9 [10.81] 30.4 [8.91] 2.6	36.2 [10.61] 29.0 [8.50] 2.6
	95 [35]	Total BTUH [kW] Sens BTUH [kW] Power	40.3 [11.81] 24.0 [7.03] 2.8	39.6 [11.61] 22.9 [6.71] 2.8	38.9 [11.40] 21.9 [6.42] 2.8	37.7 [11.05] 29.1 [8.53] 2.8	37.0 [10.84] 27.8 [8.15] 2.8	36.4 [10.67] 26.5 [7.77] 2.8	36.1 [10.58] 31.0 [9.09] 2.8	35.4 [10.37] 29.6 [8.67] 2.8	34.8 [10.20] 28.3 [8.29] 2.8
	100 [37.8]	Total BTUH [kW] Sens BTUH [kW] Power	38.8 [11.37] 23.2 [6.80] 3.0	38.1 [11.17] 22.1 [6.48] 2.9	37.4 [10.96] 21.1 [6.18] 2.9	36.1 [10.58] 28.3 [8.29] 3.0	35.5 [10.40] 27.0 [7.91] 2.9	34.8 [10.20] 25.8 [7.56] 2.9	34.5 [10.11] 30.2 [8.85] 2.9	33.9 [9.94] 28.8 [8.44] 2.9	33.3 [9.76] 27.5 [8.06] 2.9
	105 [40.6]	Total BTUH [kW] Sens BTUH [kW] Power	37.2 [10.90] 22.4 [6.56] 3.1	36.5 [10.70] 21.4 [6.27] 3.1	35.9 [10.52] 20.4 [5.98] 3.1	34.6 [10.14] 27.5 [8.06] 3.1	34.0 [9.96] 26.3 [7.71] 3.1	33.3 [9.76] 25.0 [7.33] 3.0	32.9 [9.64] 29.4 [8.62] 3.1	32.3 [9.47] 28.1 [8.24] 3.1	31.8 [9.32] 26.8 [7.85] 3.0
	110 [43.3]	Total BTUH [kW] Sens BTUH [kW] Power	35.7 [10.46] 21.8 [6.39] 3.3	35.1 [10.29] 20.8 [6.10] 3.2	34.5 [10.11] 19.8 [5.80] 3.2	33.1 [9.70] 26.9 [7.88] 3.2	32.5 [9.52] 25.7 [7.53] 3.2	31.9 [9.35] 24.5 [7.18] 3.2	31.5 [9.23] 28.8 [8.44] 3.2	30.9 [9.06] 27.5 [8.06] 3.2	30.4 [8.91] 26.2 [7.68] 3.2
	115 [46.1]	Total BTUH [kW] Sens BTUH [kW] Power	34.5 [10.11] 21.3 [6.24] 3.4	33.9 [9.94] 20.4 [5.98] 3.4	33.3 [9.76] 19.4 [5.69] 3.3	31.9 [9.35] 26.4 [7.74] 3.4	31.3 [9.17] 25.2 [7.39] 3.4	30.7 [9.00] 24.1 [7.06] 3.3	30.2 [8.85] 28.3 [8.29] 3.4	29.7 [8.70] 27.1 [7.94] 3.3	29.2 [8.56] 25.8 [7.56] 3.3

GROSS SYSTEMS PERFORMANCE DATA—B042

		ENTERING INDOOR AIR @ 80°F [26.7°C] dbE ①									
wbE		71°F [21.7°C]			67°F [19.4°C]			63°F [17.2°C]			
CFM [L/s]		1540 [727]	1400 [661]	1260 [595]	1540 [727]	1400 [661]	1260 [595]	1540 [727]	1400 [661]	1260 [595]	
DR ①		.18	.17	.15	.18	.17	.15	.18	.17	.15	
OUTDOOR DRY BULB TEMPERATURE °F [°C]	75 [23.9]	Total BTUH [kW] Sens BTUH [kW] Power	53.6 [15.71] 31.1 [9.11] 2.6	52.6 [15.42] 29.7 [8.70] 2.6	51.7 [15.15] 28.3 [8.29] 2.6	50.3 [14.74] 36.6 [10.73] 2.6	49.4 [14.48] 34.9 [10.23] 2.6	48.5 [14.21] 33.3 [9.76] 2.6	48.6 [14.24] 39.7 [11.63] 2.6	47.7 [13.98] 37.9 [11.11] 2.6	46.8 [13.72] 36.2 [10.61] 2.6
	80 [26.7]	Total BTUH [kW] Sens BTUH [kW] Power	52.1 [15.27] 30.4 [8.91] 2.8	51.1 [14.98] 29.0 [8.50] 2.7	50.2 [14.71] 27.7 [8.12] 2.7	48.7 [14.27] 35.9 [10.52] 2.8	47.9 [14.04] 34.3 [10.05] 2.7	47.0 [13.77] 32.7 [9.58] 2.7	47.0 [13.77] 39.0 [11.43] 2.8	46.2 [13.54] 37.3 [10.93] 2.7	45.4 [13.31] 35.5 [10.40] 2.7
	85 [29.4]	Total BTUH [kW] Sens BTUH [kW] Power	50.6 [14.83] 29.7 [8.70] 2.9	49.7 [14.57] 28.4 [8.32] 2.9	48.8 [14.30] 27.1 [7.94] 2.9	47.3 [13.86] 35.2 [10.32] 2.9	46.4 [13.60] 33.6 [9.85] 2.9	45.6 [13.36] 32.0 [9.38] 2.9	45.6 [13.36] 38.3 [11.22] 2.9	44.8 [13.13] 36.6 [10.73] 2.9	44.0 [12.90] 34.9 [10.23] 2.9
	90 [32.2]	Total BTUH [kW] Sens BTUH [kW] Power	49.3 [14.45] 29.0 [8.50] 3.1	48.4 [14.18] 27.7 [8.12] 3.1	47.5 [13.92] 26.4 [7.74] 3.0	45.9 [13.45] 34.5 [10.11] 3.1	45.1 [13.22] 32.9 [9.64] 3.1	44.3 [12.98] 31.4 [9.20] 3.0	44.2 [12.95] 37.6 [11.02] 3.1	43.4 [12.72] 35.9 [10.52] 3.1	42.6 [12.48] 34.3 [10.05] 3.0
	95 [35]	Total BTUH [kW] Sens BTUH [kW] Power	47.9 [14.04] 28.3 [8.29] 3.2	47.1 [13.80] 27.1 [7.94] 3.2	46.2 [13.54] 25.8 [7.56] 3.2	44.6 [13.07] 33.8 [9.91] 3.2	43.8 [12.84] 32.3 [9.47] 3.2	43.0 [12.60] 30.8 [9.03] 3.2	42.9 [12.57] 36.9 [10.81] 3.2	42.1 [12.34] 35.3 [10.35] 3.2	41.4 [12.13] 33.6 [9.85] 3.2
	100 [37.8]	Total BTUH [kW] Sens BTUH [kW] Power	46.6 [13.66] 27.6 [8.09] 3.4	45.8 [13.42] 26.4 [7.74] 3.4	44.9 [13.16] 25.1 [7.36] 3.4	43.2 [12.66] 33.1 [9.70] 3.4	42.5 [12.46] 31.6 [9.26] 3.4	41.7 [12.22] 30.1 [8.82] 3.3	41.6 [12.19] 36.2 [10.61] 3.4	40.8 [11.96] 34.6 [10.14] 3.4	40.1 [11.75] 33.0 [9.67] 3.3
	105 [40.6]	Total BTUH [kW] Sens BTUH [kW] Power	45.3 [13.28] 26.9 [7.88] 3.6	44.4 [13.01] 25.7 [7.53] 3.5	43.6 [12.78] 24.5 [7.18] 3.5	41.9 [12.28] 32.3 [9.47] 3.6	41.2 [12.07] 30.9 [9.06] 3.5	40.4 [11.84] 29.4 [8.62] 3.5	40.2 [11.78] 35.5 [10.40] 3.6	39.5 [11.58] 33.9 [9.94] 3.5	38.8 [11.37] 32.3 [9.47] 3.5
	110 [43.3]	Total BTUH [kW] Sens BTUH [kW] Power	43.9 [12.87] 26.1 [7.65] 3.7	43.1 [12.63] 24.9 [7.30] 3.7	42.3 [12.40] 23.7 [6.95] 3.7	40.5 [11.87] 31.5 [9.23] 3.7	39.8 [11.66] 30.1 [8.82] 3.7	39.1 [11.46] 28.7 [8.41] 3.7	38.8 [11.37] 34.7 [10.17] 3.7	38.2 [11.20] 33.1 [9.70] 3.7	37.5 [10.99] 31.6 [9.26] 3.7
	115 [46.1]	Total BTUH [kW] Sens BTUH [kW] Power	42.4 [12.43] 25.2 [7.39] 3.9	41.7 [12.22] 24.1 [7.06] 3.9	40.9 [11.99] 23.0 [6.74] 3.8	39.1 [11.46] 30.7 [9.00] 3.9	38.4 [11.25] 29.3 [8.59] 3.8	37.7 [11.05] 28.0 [8.21] 3.8	37.4 [10.96] 33.8 [9.91] 3.9	36.7 [10.76] 32.3 [9.47] 3.8	36.1 [10.58] 30.8 [9.03] 3.8

DR —Depression ratio
dbE—Entering air dry bulb
wbE—Entering air wet bulb

Total —Total capacity x 1000 BTUH
Sens —Sensible capacity x 1000 BTUH
Power—KW input

NOTES: ① When the entering air dry bulb is other than 80°F [27°C], adjust the sensible capacity from the table by adding [1.10 x CFM x (1 - DR) x (dbE - 80)].

[] Designates Metric Conversions



SYSTEMS PERFORMANCE—RRNL- SERIES

GROSS SYSTEMS PERFORMANCE DATA—B048

		ENTERING INDOOR AIR @ 80°F [26.7°C] dbE ①									
wbE		71°F [21.7°C]			67°F [19.4°C]			63°F [17.2°C]			
CFM [L/s]		1760 [831]	1600 [755]	1440 [680]	1760 [831]	1600 [755]	1440 [680]	1760 [831]	1600 [755]	1440 [680]	
DR ①		.22	.20	.19	.22	.20	.19	.22	.20	.19	
OUTDOOR DRY BULB TEMPERATURE °F [°C]	75 [23.9]	Total BTUH [kW] Sens BTUH [kW] Power	61.6 [18.05] 34.8 [10.20] 3.0	60.5 [17.73] 33.2 [9.73] 2.9	59.4 [17.41] 31.7 [9.29] 2.9	58.0 [17.00] 41.6 [12.19] 2.9	57.0 [16.71] 39.7 [11.63] 2.9	55.9 [16.38] 37.9 [11.11] 2.9	55.3 [16.21] 44.4 [13.01] 2.9	54.3 [15.91] 42.4 [12.43] 2.9	53.3 [15.62] 40.4 [11.84] 2.9
	80 [26.7]	Total BTUH [kW] Sens BTUH [kW] Power	59.9 [17.55] 33.7 [9.88] 3.1	58.8 [17.23] 32.2 [9.44] 3.1	57.7 [16.91] 30.7 [9.00] 3.1	56.2 [16.47] 40.5 [11.87] 3.1	55.2 [16.18] 38.7 [11.34] 3.1	54.2 [15.88] 36.9 [10.81] 3.1	53.5 [15.68] 43.3 [12.69] 3.1	52.6 [15.42] 41.4 [12.13] 3.1	51.6 [15.12] 39.4 [11.55] 3.1
	85 [29.4]	Total BTUH [kW] Sens BTUH [kW] Power	58.2 [17.06] 32.8 [9.61] 3.3	57.1 [16.73] 31.3 [9.17] 3.3	56.1 [16.44] 29.8 [8.73] 3.3	54.5 [15.97] 39.6 [11.61] 3.3	53.5 [15.68] 37.8 [11.08] 3.3	52.6 [15.42] 36.0 [10.55] 3.2	51.8 [15.18] 42.3 [12.40] 3.3	50.9 [14.92] 40.4 [11.84] 3.3	49.9 [14.62] 38.6 [11.31] 3.2
	90 [32.2]	Total BTUH [kW] Sens BTUH [kW] Power	56.4 [16.53] 31.9 [9.35] 3.5	55.4 [16.24] 30.4 [8.91] 3.5	54.4 [15.94] 29.0 [8.50] 3.4	52.8 [15.47] 38.7 [11.34] 3.5	51.8 [15.18] 36.9 [10.81] 3.4	50.9 [14.92] 35.2 [10.32] 3.4	50.1 [14.68] 41.4 [12.13] 3.5	49.2 [14.42] 39.6 [11.61] 3.4	48.3 [14.16] 37.7 [11.05] 3.4
	95 [35]	Total BTUH [kW] Sens BTUH [kW] Power	54.7 [16.03] 31.0 [9.09] 3.7	53.7 [15.74] 29.6 [8.67] 3.6	52.7 [15.44] 28.2 [8.26] 3.6	51.0 [14.95] 37.8 [11.08] 3.7	50.1 [14.68] 36.1 [10.58] 3.6	49.2 [14.42] 34.4 [10.08] 3.6	48.3 [14.16] 40.6 [11.90] 3.6	47.4 [13.89] 38.7 [11.34] 3.6	46.6 [13.66] 36.9 [10.81] 3.6
	100 [37.8]	Total BTUH [kW] Sens BTUH [kW] Power	52.9 [15.50] 30.1 [8.82] 3.9	51.9 [15.21] 28.8 [8.44] 3.8	51.0 [14.95] 27.4 [8.03] 3.8	49.2 [14.42] 36.9 [10.81] 3.8	48.3 [14.16] 35.3 [10.35] 3.8	47.5 [13.92] 33.6 [9.85] 3.8	46.5 [13.63] 39.7 [11.63] 3.8	45.7 [13.39] 37.9 [11.11] 3.8	44.8 [13.13] 36.1 [10.58] 3.8
	105 [40.6]	Total BTUH [kW] Sens BTUH [kW] Power	51.0 [14.95] 29.2 [8.56] 4.0	50.1 [14.68] 27.9 [8.18] 4.0	49.2 [14.42] 26.6 [7.80] 4.0	47.3 [13.86] 36.0 [10.55] 4.0	46.5 [13.63] 34.4 [10.08] 4.0	45.6 [13.36] 32.8 [9.61] 3.9	44.6 [13.07] 38.8 [11.37] 4.0	43.8 [12.84] 37.0 [10.84] 4.0	43.0 [12.60] 35.3 [10.35] 3.9
	110 [43.3]	Total BTUH [kW] Sens BTUH [kW] Power	49.0 [14.36] 28.2 [8.26] 4.2	48.1 [14.10] 27.0 [7.91] 4.2	47.2 [13.83] 25.7 [7.53] 4.1	45.3 [13.28] 35.0 [10.26] 4.2	44.5 [13.04] 33.5 [9.82] 4.2	43.7 [12.81] 31.9 [9.35] 4.1	42.6 [12.48] 37.8 [11.08] 4.2	41.9 [12.28] 36.1 [10.58] 4.1	41.1 [12.05] 34.4 [10.08] 4.1
	115 [46.1]	Total BTUH [kW] Sens BTUH [kW] Power	46.9 [13.75] 27.1 [7.94] 4.4	46.1 [13.51] 25.9 [7.59] 4.4	45.2 [13.25] 24.7 [7.24] 4.3	43.2 [12.66] 33.9 [9.94] 4.4	42.5 [12.46] 32.4 [9.50] 4.3	41.7 [12.22] 30.9 [9.06] 4.3	40.5 [11.87] 36.7 [10.76] 4.4	39.8 [11.66] 35.1 [10.29] 4.3	39.1 [11.46] 33.4 [9.79] 4.3

GROSS SYSTEMS PERFORMANCE DATA—C060

		ENTERING INDOOR AIR @ 80°F [26.7°C] dbE ①									
wbE		71°F [21.7°C]			67°F [19.4°C]			63°F [17.2°C]			
CFM [L/s]		2040 [963]	1850 [873]	1660 [783]	2040 [963]	1850 [873]	1660 [783]	2040 [963]	1850 [873]	1660 [783]	
DR ①		.21	.20	.18	.21	.20	.18	.21	.20	.18	
OUTDOOR DRY BULB TEMPERATURE °F [°C]	75 [23.9]	Total BTUH [kW] Sens BTUH [kW] Power	73.6 [21.57] 42.2 [12.37] 4.0	72.3 [21.19] 40.3 [11.81] 3.9	71.0 [20.81] 38.4 [11.25] 3.9	68.5 [20.08] 49.1 [14.39] 3.9	67.3 [19.72] 46.9 [13.75] 3.8	66.1 [19.37] 44.7 [13.10] 3.8	65.9 [19.31] 53.3 [15.62] 3.8	64.7 [18.96] 50.9 [14.92] 3.8	63.5 [18.61] 48.5 [14.21] 3.7
	80 [26.7]	Total BTUH [kW] Sens BTUH [kW] Power	71.3 [20.90] 40.7 [11.93] 4.2	70.0 [20.51] 38.9 [11.40] 4.1	68.7 [20.13] 37.1 [10.87] 4.1	66.2 [19.40] 47.7 [13.98] 4.1	65.0 [19.05] 45.5 [13.33] 4.0	63.9 [18.73] 43.4 [12.72] 4.0	63.6 [18.64] 51.8 [15.18] 4.0	62.4 [18.29] 49.5 [14.51] 4.0	61.3 [17.97] 47.2 [13.83] 3.9
	85 [29.4]	Total BTUH [kW] Sens BTUH [kW] Power	69.3 [20.31] 39.5 [11.58] 4.4	68.1 [19.96] 37.8 [11.08] 4.4	66.8 [19.58] 36.0 [10.55] 4.3	64.2 [18.82] 46.5 [13.63] 4.3	63.1 [18.49] 44.4 [13.01] 4.3	61.9 [18.14] 42.3 [12.40] 4.2	61.6 [18.05] 50.6 [14.83] 4.2	60.5 [17.73] 48.3 [14.16] 4.2	59.4 [17.41] 46.1 [13.51] 4.1
	90 [32.2]	Total BTUH [kW] Sens BTUH [kW] Power	67.5 [19.78] 38.5 [11.28] 4.6	66.3 [19.43] 36.8 [10.79] 4.6	65.1 [19.08] 35.1 [10.29] 4.5	62.5 [18.32] 45.5 [13.33] 4.5	61.3 [17.97] 43.5 [12.75] 4.5	60.2 [17.64] 41.4 [12.13] 4.4	59.8 [17.53] 49.6 [14.54] 4.4	58.7 [17.20] 47.4 [13.89] 4.4	57.6 [16.88] 45.2 [13.25] 4.4
	95 [35]	Total BTUH [kW] Sens BTUH [kW] Power	65.8 [19.28] 37.7 [11.05] 4.8	64.7 [18.96] 36.0 [10.55] 4.8	63.5 [18.61] 34.3 [10.05] 4.7	60.8 [17.82] 44.6 [13.07] 4.7	59.7 [17.50] 42.6 [12.48] 4.7	58.6 [17.17] 40.7 [11.93] 4.6	58.1 [17.03] 48.8 [14.30] 4.6	57.1 [16.73] 46.6 [13.66] 4.6	56.0 [16.41] 44.4 [13.01] 4.6
	100 [37.8]	Total BTUH [kW] Sens BTUH [kW] Power	64.2 [18.82] 36.9 [10.81] 5.0	63.0 [18.46] 35.3 [10.35] 5.0	61.9 [18.14] 33.6 [9.85] 4.9	59.1 [17.32] 43.9 [12.87] 4.9	58.0 [17.00] 41.9 [12.28] 4.9	57.0 [16.71] 39.9 [11.69] 4.8	56.4 [16.53] 48.0 [14.07] 4.9	55.4 [16.24] 45.8 [13.42] 4.8	54.4 [15.94] 43.7 [12.81] 4.8
	105 [40.6]	Total BTUH [kW] Sens BTUH [kW] Power	62.4 [18.29] 36.1 [10.58] 5.2	61.3 [17.97] 34.5 [10.11] 5.2	60.1 [17.61] 32.9 [9.64] 5.2	57.3 [16.79] 43.1 [12.63] 5.1	56.3 [16.50] 41.2 [12.07] 5.1	55.3 [16.21] 39.2 [11.49] 5.1	54.6 [16.00] 47.2 [13.83] 5.1	53.7 [15.74] 45.1 [13.22] 5.0	52.7 [15.44] 43.0 [12.60] 5.0
	110 [43.3]	Total BTUH [kW] Sens BTUH [kW] Power	60.4 [17.70] 35.3 [10.35] 5.5	59.3 [17.38] 33.7 [9.88] 5.4	58.2 [17.06] 32.2 [9.44] 5.4	55.3 [16.21] 42.3 [12.40] 5.4	54.3 [15.91] 40.4 [11.84] 5.3	53.4 [15.65] 38.5 [11.28] 5.3	52.7 [15.44] 46.4 [13.60] 5.3	51.7 [15.15] 44.3 [12.98] 5.2	50.8 [14.89] 42.2 [12.37] 5.2
	115 [46.1]	Total BTUH [kW] Sens BTUH [kW] Power	58.1 [17.03] 34.4 [10.08] 5.7	57.1 [16.73] 32.8 [9.61] 5.6	56.0 [16.41] 31.3 [9.17] 5.6	53.0 [15.53] 41.3 [12.10] 5.6	52.1 [15.27] 39.5 [11.58] 5.5	51.1 [14.98] 37.6 [11.02] 5.5	50.4 [14.77] 45.4 [13.31] 5.5	49.5 [14.51] 43.4 [12.72] 5.4	48.6 [14.24] 41.4 [12.13] 5.4

DR —Depression ratio
dbE—Entering air dry bulb
wbE—Entering air wet bulb

Total —Total capacity x 1000 BTUH
Sens —Sensible capacity x 1000 BTUH
Power—KW input

NOTES: ① When the entering air dry bulb is other than 80°F [27°C], adjust the sensible capacity from the table by adding $[1.10 \times \text{CFM} \times (1 - \text{DR}) \times (\text{dbE} - 80)]$.

[] Designates Metric Conversions



GROSS SYSTEMS PERFORMANCE DATA—B024

		ENTERING INDOOR AIR @ 80°F [26.7°C] dbE ①									
		71°F [21.7°C]			67°F [19.4°C]			63°F [17.2°C]			
wbE		880 [415]	800 [378]	720 [340]	880 [415]	800 [378]	720 [340]	880 [415]	800 [378]	720 [340]	
CFM [L/s]											
DR ①		.19	.17	.15	.19	.17	.15	.19	.17	.15	
OUTDOOR DRY BULB TEMPERATURE °F [°C]	75 [23.9]	Total BTUH [kW] Sens BTUH [kW] Power	29.6 [8.67] 17.6 [5.16] 1.5	29.1 [8.53] 16.8 [4.92] 1.5	28.5 [8.35] 16.0 [4.69] 1.5	27.8 [8.15] 20.7 [6.07] 1.5	27.3 [8.00] 19.8 [5.80] 1.5	26.8 [7.85] 18.9 [5.54] 1.5	26.6 [7.80] 22.2 [6.51] 1.5	26.1 [7.65] 21.2 [6.21] 1.5	25.6 [7.50] 20.2 [5.92] 1.5
	80 [26.7]	Total BTUH [kW] Sens BTUH [kW] Power	29.0 [8.50] 17.3 [5.07] 1.6	28.5 [8.35] 16.5 [4.84] 1.6	28.0 [8.21] 15.7 [4.60] 1.6	27.2 [7.97] 20.4 [5.98] 1.6	26.7 [7.83] 19.5 [5.71] 1.6	26.3 [7.71] 18.5 [5.42] 1.6	26.0 [7.62] 21.9 [6.42] 1.6	25.5 [7.47] 20.9 [6.13] 1.6	25.1 [7.36] 19.9 [5.83] 1.6
	85 [29.4]	Total BTUH [kW] Sens BTUH [kW] Power	28.3 [8.29] 16.8 [4.92] 1.7	27.8 [8.15] 16.1 [4.72] 1.7	27.3 [8.00] 15.3 [4.48] 1.7	26.5 [7.77] 19.9 [5.83] 1.7	26.0 [7.62] 19.1 [5.60] 1.7	25.6 [7.50] 18.2 [5.33] 1.7	25.3 [7.41] 21.4 [6.27] 1.7	24.8 [7.27] 20.5 [6.01] 1.7	24.4 [7.15] 19.5 [5.71] 1.7
	90 [32.2]	Total BTUH [kW] Sens BTUH [kW] Power	27.5 [8.06] 16.4 [4.81] 1.8	27.0 [7.91] 15.6 [4.57] 1.8	26.5 [7.77] 14.9 [4.37] 1.8	25.7 [7.53] 19.5 [5.71] 1.8	25.2 [7.39] 18.6 [5.45] 1.8	24.8 [7.27] 17.7 [5.19] 1.8	24.5 [7.18] 21.0 [6.15] 1.8	24.0 [7.03] 20.0 [5.86] 1.8	23.6 [6.92] 19.1 [5.60] 1.8
	95 [35]	Total BTUH [kW] Sens BTUH [kW] Power	26.6 [7.80] 15.9 [4.66] 1.9	26.1 [7.65] 15.2 [4.45] 1.9	25.7 [7.53] 14.5 [4.25] 1.9	24.8 [7.27] 19.0 [5.57] 1.9	24.4 [7.15] 18.2 [5.33] 1.9	23.9 [7.00] 17.3 [5.07] 1.9	23.6 [6.92] 20.5 [6.01] 1.9	23.2 [6.80] 19.6 [5.74] 1.9	22.8 [6.68] 18.7 [5.48] 1.9
	100 [37.8]	Total BTUH [kW] Sens BTUH [kW] Power	25.7 [7.53] 15.5 [4.54] 2.0	25.2 [7.39] 14.8 [4.34] 2.0	24.8 [7.27] 14.1 [4.13] 2.0	23.9 [7.00] 18.6 [5.45] 2.0	23.5 [6.89] 17.7 [5.19] 2.0	23.1 [6.77] 16.9 [4.95] 2.0	22.7 [6.65] 20.1 [5.89] 2.0	22.3 [6.54] 19.2 [5.63] 2.0	21.9 [6.42] 18.3 [5.36] 2.0
	105 [40.6]	Total BTUH [kW] Sens BTUH [kW] Power	24.8 [7.27] 15.1 [4.43] 2.1	24.4 [7.15] 14.4 [4.22] 2.1	23.9 [7.00] 13.7 [4.02] 2.1	23.0 [6.74] 18.2 [5.33] 2.1	22.6 [6.62] 17.4 [5.10] 2.1	22.2 [6.51] 16.6 [4.86] 2.1	21.8 [6.39] 19.7 [5.77] 2.1	21.4 [6.27] 18.8 [5.51] 2.1	21.0 [6.15] 17.9 [5.25] 2.1
	110 [43.3]	Total BTUH [kW] Sens BTUH [kW] Power	24.0 [7.03] 14.8 [4.34] 2.2	23.5 [6.89] 14.2 [4.16] 2.2	23.1 [6.77] 13.5 [3.96] 2.2	22.2 [6.51] 17.9 [5.25] 2.2	21.8 [6.39] 17.1 [5.01] 2.2	21.4 [6.27] 16.3 [4.78] 2.2	21.0 [6.15] 19.4 [5.69] 2.2	20.6 [6.04] 18.6 [5.45] 2.2	20.2 [5.92] 17.7 [5.19] 2.2
	115 [46.1]	Total BTUH [kW] Sens BTUH [kW] Power	23.2 [6.80] 14.7 [4.31] 2.3	22.8 [6.68] 14.0 [4.10] 2.3	22.4 [6.56] 13.4 [3.93] 2.2	21.4 [6.27] 17.8 [5.22] 2.3	21.0 [6.15] 17.0 [4.98] 2.3	20.7 [6.07] 16.2 [4.75] 2.2	20.2 [5.92] 19.3 [5.66] 2.3	19.8 [5.80] 18.4 [5.39] 2.3	19.5 [5.71] 17.6 [5.16] 2.2

GROSS SYSTEMS PERFORMANCE DATA—B030

		ENTERING INDOOR AIR @ 80°F [26.7°C] dbE ①									
		71°F [21.7°C]			67°F [19.4°C]			63°F [17.2°C]			
wbE		1100 [519]	1000 [472]	900 [425]	1100 [519]	1000 [472]	900 [425]	1100 [519]	1000 [472]	900 [425]	
CFM [L/s]											
DR ①		.20	.19	.17	.20	.19	.17	.20	.19	.17	
OUTDOOR DRY BULB TEMPERATURE °F [°C]	75 [23.9]	Total BTUH [kW] Sens BTUH [kW] Power	36.7 [10.76] 21.5 [6.30] 1.8	36.1 [10.58] 20.6 [6.04] 1.8	35.4 [10.37] 19.6 [5.74] 1.8	34.5 [10.11] 25.7 [7.53] 1.8	33.9 [9.94] 24.6 [7.21] 1.8	33.3 [9.76] 23.4 [6.86] 1.8	33.1 [9.70] 27.4 [8.03] 1.8	32.5 [9.52] 26.2 [7.68] 1.8	32.0 [9.38] 25.0 [7.33] 1.8
	80 [26.7]	Total BTUH [kW] Sens BTUH [kW] Power	35.8 [10.49] 20.9 [6.13] 1.9	35.2 [10.32] 20.0 [5.86] 1.9	34.5 [10.11] 19.0 [5.57] 1.9	33.6 [9.85] 25.1 [7.36] 1.9	33.0 [9.67] 24.0 [7.03] 1.9	32.4 [9.50] 22.9 [6.71] 1.9	32.2 [9.44] 26.8 [7.85] 1.9	31.6 [9.26] 25.6 [7.50] 1.9	31.1 [9.11] 24.4 [7.15] 1.9
	85 [29.4]	Total BTUH [kW] Sens BTUH [kW] Power	34.8 [10.20] 20.3 [5.95] 2.0	34.2 [10.02] 19.4 [5.69] 2.0	33.5 [9.82] 18.5 [5.42] 2.0	32.6 [9.55] 24.5 [7.18] 2.0	32.0 [9.38] 23.4 [6.86] 2.0	31.4 [9.20] 22.3 [6.54] 2.0	31.2 [9.14] 26.1 [7.65] 2.0	30.6 [8.97] 25.0 [7.33] 2.0	30.1 [8.82] 23.8 [6.98] 2.0
	90 [32.2]	Total BTUH [kW] Sens BTUH [kW] Power	33.7 [9.88] 19.7 [5.77] 2.1	33.1 [9.70] 18.8 [5.51] 2.1	32.5 [9.52] 17.9 [5.25] 2.1	31.4 [9.20] 23.8 [6.98] 2.1	30.9 [9.06] 22.8 [6.68] 2.1	30.3 [8.88] 21.7 [6.36] 2.1	30.1 [8.82] 25.5 [7.47] 2.1	29.5 [8.65] 24.4 [7.15] 2.1	29.0 [8.50] 23.3 [6.83] 2.1
	95 [35]	Total BTUH [kW] Sens BTUH [kW] Power	32.4 [9.50] 19.0 [5.57] 2.3	31.9 [9.35] 18.2 [5.33] 2.2	31.3 [9.17] 17.3 [5.07] 2.2	30.2 [8.85] 23.2 [6.80] 2.3	29.7 [8.70] 22.2 [6.51] 2.2	29.1 [8.53] 21.1 [6.18] 2.2	28.9 [8.47] 24.9 [7.30] 2.2	28.3 [8.29] 23.8 [6.98] 2.2	27.8 [8.15] 22.7 [6.65] 2.2
	100 [37.8]	Total BTUH [kW] Sens BTUH [kW] Power	31.2 [9.14] 18.4 [5.39] 2.4	30.6 [8.97] 17.6 [5.16] 2.3	30.1 [8.82] 16.7 [4.89] 2.3	28.9 [8.47] 22.6 [6.62] 2.4	28.4 [8.32] 21.6 [6.33] 2.3	27.9 [8.18] 20.5 [6.01] 2.3	27.6 [8.09] 24.2 [7.09] 2.4	27.1 [7.94] 23.2 [6.80] 2.3	26.6 [7.80] 22.1 [6.48] 2.3
	105 [40.6]	Total BTUH [kW] Sens BTUH [kW] Power	29.8 [8.73] 17.7 [5.19] 2.5	29.3 [8.59] 16.9 [4.95] 2.5	28.8 [8.44] 16.1 [4.72] 2.4	27.6 [8.09] 21.9 [6.42] 2.5	27.1 [7.94] 20.9 [6.13] 2.5	26.6 [7.80] 19.9 [5.83] 2.4	26.2 [7.68] 23.5 [6.89] 2.5	25.8 [7.56] 22.5 [6.59] 2.4	25.3 [7.41] 21.4 [6.27] 2.4
	110 [43.3]	Total BTUH [kW] Sens BTUH [kW] Power	28.5 [8.35] 16.9 [4.95] 2.6	27.9 [8.18] 16.2 [4.75] 2.6	27.4 [8.03] 15.4 [4.51] 2.5	26.2 [7.68] 21.1 [6.18] 2.6	25.8 [7.56] 20.2 [5.92] 2.6	25.3 [7.41] 19.2 [5.63] 2.5	24.9 [7.30] 22.8 [6.68] 2.6	24.4 [7.15] 21.8 [6.39] 2.6	24.0 [7.03] 20.8 [6.10] 2.5
	115 [46.1]	Total BTUH [kW] Sens BTUH [kW] Power	27.1 [7.94] 16.2 [4.75] 2.7	26.6 [7.80] 15.4 [4.51] 2.7	26.1 [7.65] 14.7 [4.31] 2.6	24.8 [7.27] 20.3 [5.95] 2.7	24.4 [7.15] 19.4 [5.69] 2.7	23.9 [7.00] 18.5 [5.42] 2.6	23.5 [6.89] 22.0 [6.45] 2.7	23.0 [6.74] 21.0 [6.15] 2.7	22.6 [6.62] 20.1 [5.89] 2.6

DR —Depression ratio
dbE—Entering air dry bulb
wbE—Entering air wet bulb

Total —Total capacity x 1000 BTUH
Sens —Sensible capacity x 1000 BTUH
Power—kW input

NOTES: ① When the entering air dry bulb is other than 80°F [27°C], adjust the sensible capacity from the table by adding [1.10 x CFM x (1 - DR) x (dbE - 80)].

[] Designates Metric Conversions



SYSTEMS PERFORMANCE—RRPL- SERIES

GROSS SYSTEMS PERFORMANCE DATA—B036

		ENTERING INDOOR AIR @ 80°F [26.7°C] dbE ①									
wbE		71°F [21.7°C]			67°F [19.4°C]			63°F [17.2°C]			
CFM [L/s]		1320 [623]	1200 [566]	1080 [510]	1320 [623]	1200 [566]	1080 [510]	1320 [623]	1200 [566]	1080 [510]	
DR ①		.19	.18	.16	.19	.18	.16	.19	.18	.16	
OUTDOOR DRY BULB TEMPERATURE °F [°C]	75 [23.9]	Total BTUH [kW] Sens BTUH [kW] Power	44.7 [13.10] 25.8 [7.56] 2.2	43.9 [12.87] 24.7 [7.24] 2.2	43.1 [12.63] 23.5 [6.89] 2.2	42.1 [12.34] 31.0 [9.09] 2.2	41.3 [12.10] 29.6 [8.67] 2.2	40.6 [11.90] 28.2 [8.26] 2.2	40.4 [11.84] 32.9 [9.64] 2.2	39.7 [11.63] 31.5 [9.23] 2.2	39.0 [11.43] 30.0 [8.79] 2.1
	80 [26.7]	Total BTUH [kW] Sens BTUH [kW] Power	44.0 [12.90] 25.5 [7.47] 2.3	43.3 [12.69] 24.3 [7.12] 2.3	42.5 [12.46] 23.2 [6.80] 2.3	41.4 [12.13] 30.7 [9.00] 2.3	40.6 [11.90] 29.3 [8.59] 2.3	39.9 [11.69] 27.9 [8.18] 2.3	39.7 [11.63] 32.6 [9.55] 2.3	39.0 [11.43] 31.1 [9.11] 2.3	38.3 [11.22] 29.7 [8.70] 2.3
	85 [29.4]	Total BTUH [kW] Sens BTUH [kW] Power	43.0 [12.60] 24.9 [7.30] 2.5	42.2 [12.37] 23.8 [6.98] 2.5	41.4 [12.13] 22.7 [6.65] 2.4	40.3 [11.81] 30.1 [8.82] 2.5	39.6 [11.61] 28.7 [8.41] 2.4	38.9 [11.40] 27.4 [8.03] 2.4	38.6 [11.31] 32.0 [9.38] 2.5	38.0 [11.14] 30.6 [8.97] 2.4	37.3 [10.93] 29.1 [8.53] 2.4
	90 [32.2]	Total BTUH [kW] Sens BTUH [kW] Power	41.6 [12.19] 24.1 [7.06] 2.6	40.9 [11.99] 23.1 [6.77] 2.6	40.1 [11.75] 22.0 [6.45] 2.6	39.0 [11.43] 29.3 [8.59] 2.6	38.3 [11.22] 28.0 [8.21] 2.6	37.6 [11.02] 26.7 [7.83] 2.6	37.3 [10.93] 31.2 [9.14] 2.6	36.6 [10.73] 29.9 [8.76] 2.6	36.0 [10.55] 28.5 [8.35] 2.5
	95 [35]	Total BTUH [kW] Sens BTUH [kW] Power	40.1 [11.75] 23.3 [6.83] 2.7	39.4 [11.55] 22.3 [6.54] 2.7	38.7 [11.34] 21.2 [6.21] 2.7	37.5 [10.99] 28.5 [8.35] 2.7	36.8 [10.79] 27.2 [7.97] 2.7	36.1 [10.58] 25.9 [7.59] 2.7	35.8 [10.49] 30.4 [8.91] 2.7	35.2 [10.32] 29.1 [8.53] 2.7	34.5 [10.11] 27.7 [8.12] 2.7
	100 [37.8]	Total BTUH [kW] Sens BTUH [kW] Power	38.5 [11.28] 22.4 [6.56] 2.9	37.8 [11.08] 21.4 [6.27] 2.9	37.1 [10.87] 20.4 [5.98] 2.8	35.9 [10.52] 27.6 [8.09] 2.9	35.2 [10.32] 26.4 [7.74] 2.8	34.6 [10.14] 25.2 [7.39] 2.8	34.2 [10.02] 29.6 [8.67] 2.9	33.6 [9.85] 28.2 [8.26] 2.8	33.0 [9.67] 26.9 [7.88] 2.8
	105 [40.6]	Total BTUH [kW] Sens BTUH [kW] Power	36.9 [10.81] 21.6 [6.33] 3.0	36.3 [10.64] 20.7 [6.07] 3.0	35.6 [10.43] 19.7 [5.77] 3.0	34.3 [10.05] 26.8 [7.85] 3.0	33.7 [9.88] 25.6 [7.50] 3.0	33.0 [9.67] 24.4 [7.15] 3.0	32.6 [9.55] 28.8 [8.44] 3.0	32.0 [9.38] 27.5 [8.06] 3.0	31.4 [9.20] 26.2 [7.68] 2.9
	110 [43.3]	Total BTUH [kW] Sens BTUH [kW] Power	35.5 [10.40] 21.0 [6.15] 3.2	34.8 [10.20] 20.1 [5.89] 3.1	34.2 [10.02] 19.1 [5.60] 3.1	32.8 [9.61] 26.2 [7.68] 3.1	32.2 [9.44] 25.0 [7.33] 3.1	31.6 [9.26] 23.8 [6.98] 3.1	31.1 [9.11] 28.1 [8.24] 3.1	30.6 [8.97] 26.9 [7.88] 3.1	30.0 [8.79] 25.6 [7.50] 3.1
	115 [46.1]	Total BTUH [kW] Sens BTUH [kW] Power	34.2 [10.02] 20.6 [6.04] 3.3	33.6 [9.85] 19.6 [5.74] 3.3	33.0 [9.67] 18.7 [5.48] 3.2	31.5 [9.23] 25.7 [7.53] 3.3	31.0 [9.09] 24.6 [7.21] 3.2	30.4 [8.91] 23.4 [6.86] 3.2	29.9 [8.76] 27.7 [8.12] 3.3	29.3 [8.59] 26.4 [7.74] 3.2	28.8 [8.44] 25.2 [7.39] 3.2

GROSS SYSTEMS PERFORMANCE DATA—B042

		ENTERING INDOOR AIR @ 80°F [26.7°C] dbE ①									
wbE		71°F [21.7°C]			67°F [19.4°C]			63°F [17.2°C]			
CFM [L/s]		1540 [727]	1400 [661]	1260 [595]	1540 [727]	1400 [661]	1260 [595]	1540 [727]	1400 [661]	1260 [595]	
DR ①		.19	.17	.16	.19	.17	.16	.19	.17	.16	
OUTDOOR DRY BULB TEMPERATURE °F [°C]	75 [23.9]	Total BTUH [kW] Sens BTUH [kW] Power	54.0 [15.83] 31.1 [9.11] 2.7	53.0 [15.53] 29.7 [8.70] 2.7	52.1 [15.27] 28.3 [8.29] 2.6	50.6 [14.83] 36.6 [10.73] 2.7	49.7 [14.57] 35.0 [10.26] 2.6	48.8 [14.30] 33.4 [9.79] 2.6	48.9 [14.33] 39.8 [11.66] 2.7	48.0 [14.07] 38.1 [11.17] 2.6	47.2 [13.83] 36.3 [10.64] 2.6
	80 [26.7]	Total BTUH [kW] Sens BTUH [kW] Power	52.4 [15.36] 30.4 [8.91] 2.8	51.5 [15.09] 29.0 [8.50] 2.8	50.6 [14.83] 27.7 [8.12] 2.8	49.0 [14.36] 35.9 [10.52] 2.8	48.2 [14.13] 34.3 [10.05] 2.8	47.3 [13.86] 32.7 [9.58] 2.8	47.3 [13.86] 39.1 [11.46] 2.8	46.5 [13.63] 37.4 [10.96] 2.8	45.7 [13.39] 35.6 [10.43] 2.8
	85 [29.4]	Total BTUH [kW] Sens BTUH [kW] Power	51.0 [14.95] 29.7 [8.70] 3.0	50.1 [14.68] 28.3 [8.29] 3.0	49.2 [14.42] 27.0 [7.91] 2.9	47.6 [13.95] 35.2 [10.32] 3.0	46.7 [13.69] 33.6 [9.85] 2.9	45.9 [13.45] 32.1 [9.41] 2.9	45.9 [13.45] 38.4 [11.25] 3.0	45.1 [13.22] 36.7 [10.76] 2.9	44.2 [12.95] 35.0 [10.26] 2.9
	90 [32.2]	Total BTUH [kW] Sens BTUH [kW] Power	49.6 [14.54] 29.0 [8.50] 3.1	48.7 [14.27] 27.7 [8.12] 3.1	47.8 [14.01] 26.4 [7.74] 3.1	46.2 [13.54] 34.5 [10.11] 3.1	45.4 [13.31] 33.0 [9.67] 3.1	44.5 [13.04] 31.4 [9.20] 3.1	44.5 [13.04] 37.7 [11.05] 3.1	43.7 [12.81] 36.0 [10.55] 3.1	42.9 [12.57] 34.3 [10.05] 3.1
	95 [35]	Total BTUH [kW] Sens BTUH [kW] Power	48.2 [14.13] 28.3 [8.29] 3.3	47.4 [13.89] 27.0 [7.91] 3.3	46.5 [13.63] 25.7 [7.53] 3.2	44.8 [13.13] 33.8 [9.91] 3.3	44.0 [12.90] 32.3 [9.47] 3.2	43.2 [12.66] 30.8 [9.03] 3.2	43.1 [12.63] 37.0 [10.84] 3.3	42.4 [12.43] 35.3 [10.35] 3.2	41.6 [12.19] 33.7 [9.88] 3.2
	100 [37.8]	Total BTUH [kW] Sens BTUH [kW] Power	46.9 [13.75] 27.5 [8.06] 3.4	46.0 [13.48] 26.3 [7.71] 3.4	45.2 [13.25] 25.1 [7.36] 3.4	43.5 [12.75] 33.1 [9.70] 3.4	42.7 [12.51] 31.6 [9.26] 3.4	41.9 [12.28] 30.1 [8.82] 3.4	41.8 [12.25] 36.3 [10.64] 3.4	41.0 [12.02] 34.7 [10.17] 3.4	40.3 [11.81] 33.0 [9.67] 3.4
	105 [40.6]	Total BTUH [kW] Sens BTUH [kW] Power	45.5 [13.33] 26.8 [7.85] 3.6	44.7 [13.10] 25.6 [7.50] 3.6	43.9 [12.87] 24.4 [7.15] 3.5	42.1 [12.34] 32.3 [9.47] 3.6	41.4 [12.13] 30.9 [9.06] 3.5	40.6 [11.90] 29.4 [8.62] 3.5	40.4 [11.84] 35.5 [10.40] 3.6	39.7 [11.63] 33.9 [9.94] 3.5	39.0 [11.43] 32.3 [9.47] 3.5
	110 [43.3]	Total BTUH [kW] Sens BTUH [kW] Power	44.1 [12.92] 26.0 [7.62] 3.7	43.3 [12.69] 24.8 [7.27] 3.7	42.5 [12.46] 23.7 [6.95] 3.7	40.7 [11.93] 31.5 [9.23] 3.7	40.0 [11.72] 30.1 [8.82] 3.7	39.3 [11.52] 28.7 [8.41] 3.7	39.0 [11.43] 34.7 [10.17] 3.7	38.3 [11.22] 33.2 [9.73] 3.7	37.6 [11.02] 31.6 [9.26] 3.7
	115 [46.1]	Total BTUH [kW] Sens BTUH [kW] Power	42.7 [12.51] 25.1 [7.36] 3.9	41.9 [12.28] 24.0 [7.03] 3.9	41.1 [12.05] 22.9 [6.71] 3.8	39.3 [11.52] 30.7 [9.00] 3.9	38.6 [11.31] 29.3 [8.59] 3.8	37.9 [11.11] 27.9 [8.18] 3.8	37.6 [11.02] 33.8 [9.91] 3.9	36.9 [10.81] 32.3 [9.47] 3.8	36.2 [10.61] 30.8 [9.03] 3.8

DR —Depression ratio
dbE—Entering air dry bulb
wbE—Entering air wet bulb

Total —Total capacity x 1000 BTUH
Sens —Sensible capacity x 1000 BTUH
Power—KW input

NOTES: ① When the entering air dry bulb is other than 80°F [27°C], adjust the sensible capacity from the table by adding $[1.10 \times \text{CFM} \times (1 - \text{DR}) \times (\text{dbE} - 80)]$.

[] Designates Metric Conversions



GROSS SYSTEMS PERFORMANCE DATA—B048

		ENTERING INDOOR AIR @ 80°F [26.7°C] dbE ①									
		wbE	71°F [21.7°C]			67°F [19.4°C]			63°F [17.2°C]		
		CFM [L/s]	1760 [831]	1600 [755]	1440 [680]	1760 [831]	1600 [755]	1440 [680]	1760 [831]	1600 [755]	1440 [680]
		DR ①	.21	.20	.18	.21	.20	.18	.21	.20	.18
OUTDOOR DRY BULB TEMPERATURE °F [°C]	75 [23.9]	Total BTUH [kW] Sens BTUH [kW] Power	62.0 [18.17] 35.0 [10.26] 3.0	60.9 [17.85] 33.4 [9.79] 3.0	59.8 [17.53] 31.9 [9.35] 3.0	58.3 [17.09] 41.9 [12.28] 3.0	57.3 [16.79] 40.0 [11.72] 3.0	56.3 [16.50] 38.1 [11.17] 2.9	55.6 [16.29] 44.7 [13.10] 3.0	54.6 [16.00] 42.7 [12.51] 3.0	53.6 [15.71] 40.7 [11.93] 2.9
	80 [26.7]	Total BTUH [kW] Sens BTUH [kW] Power	60.3 [17.67] 33.9 [9.94] 3.2	59.2 [17.35] 32.4 [9.50] 3.2	58.1 [17.03] 30.9 [9.06] 3.1	56.6 [16.59] 40.8 [11.96] 3.2	55.5 [16.27] 39.0 [11.43] 3.1	54.5 [15.97] 37.2 [10.90] 3.1	53.8 [15.77] 43.6 [12.78] 3.2	52.8 [15.47] 41.7 [12.22] 3.1	51.9 [15.21] 39.7 [11.63] 3.1
	85 [29.4]	Total BTUH [kW] Sens BTUH [kW] Power	58.5 [17.14] 32.9 [9.64] 3.4	57.5 [16.85] 31.5 [9.23] 3.3	56.4 [16.53] 30.0 [8.79] 3.3	54.8 [16.06] 39.8 [11.66] 3.3	53.8 [15.77] 38.1 [11.17] 3.3	52.8 [15.47] 36.3 [10.64] 3.3	52.0 [15.24] 42.6 [12.48] 3.3	51.1 [14.98] 40.7 [11.93] 3.3	50.2 [14.71] 38.8 [11.37] 3.3
	90 [32.2]	Total BTUH [kW] Sens BTUH [kW] Power	56.7 [16.62] 32.0 [9.38] 3.5	55.7 [16.32] 30.6 [8.97] 3.5	54.7 [16.03] 29.2 [8.56] 3.5	53.0 [15.53] 38.9 [11.40] 3.5	52.1 [15.27] 37.2 [10.90] 3.5	51.1 [14.98] 35.4 [10.37] 3.4	50.3 [14.74] 41.7 [12.22] 3.5	49.4 [14.48] 39.9 [11.69] 3.5	48.5 [14.21] 38.0 [11.14] 3.4
	95 [35]	Total BTUH [kW] Sens BTUH [kW] Power	55.0 [16.12] 31.1 [9.11] 3.7	54.0 [15.83] 29.7 [8.70] 3.7	53.0 [15.53] 28.3 [8.29] 3.6	51.3 [15.03] 38.0 [11.14] 3.7	50.3 [14.74] 36.3 [10.64] 3.6	49.4 [14.48] 34.6 [10.14] 3.6	48.5 [14.21] 40.8 [11.96] 3.7	47.6 [13.95] 39.0 [11.43] 3.6	46.8 [13.72] 37.2 [10.90] 3.6
	100 [37.8]	Total BTUH [kW] Sens BTUH [kW] Power	53.1 [15.56] 30.2 [8.85] 3.9	52.2 [15.30] 28.9 [8.47] 3.8	51.2 [15.01] 27.5 [8.06] 3.8	49.4 [14.48] 37.1 [10.87] 3.8	48.5 [14.21] 35.5 [10.40] 3.8	47.7 [13.98] 33.8 [9.91] 3.8	46.7 [13.69] 40.0 [11.72] 3.8	45.8 [13.42] 38.2 [11.20] 3.8	45.0 [13.19] 36.4 [10.67] 3.8
	105 [40.6]	Total BTUH [kW] Sens BTUH [kW] Power	51.2 [15.01] 29.3 [8.59] 4.0	50.3 [14.74] 28.0 [8.21] 4.0	49.4 [14.48] 26.7 [7.83] 4.0	47.5 [13.92] 36.2 [10.61] 4.0	46.7 [13.69] 34.6 [10.14] 4.0	45.8 [13.42] 33.0 [9.67] 3.9	44.8 [13.13] 39.0 [11.43] 4.0	44.0 [12.90] 37.3 [10.93] 4.0	43.2 [12.66] 35.5 [10.40] 3.9
	110 [43.3]	Total BTUH [kW] Sens BTUH [kW] Power	49.2 [14.42] 28.3 [8.29] 4.2	48.3 [14.16] 27.1 [7.94] 4.2	47.5 [13.92] 25.8 [7.56] 4.1	45.5 [13.33] 35.2 [10.32] 4.2	44.7 [13.10] 33.6 [9.85] 4.1	43.9 [12.87] 32.1 [9.41] 4.1	42.8 [12.54] 38.0 [11.14] 4.2	42.0 [12.31] 36.3 [10.64] 4.1	41.2 [12.07] 34.6 [10.14] 4.1
	115 [46.1]	Total BTUH [kW] Sens BTUH [kW] Power	47.1 [13.80] 27.2 [7.97] 4.4	46.2 [13.54] 26.0 [7.62] 4.3	45.4 [13.31] 24.8 [7.27] 4.3	43.4 [12.72] 34.1 [9.99] 4.3	42.6 [12.48] 32.6 [9.55] 4.3	41.8 [12.25] 31.1 [9.11] 4.3	40.6 [11.90] 36.9 [10.81] 4.3	39.9 [11.69] 35.3 [10.35] 4.3	39.2 [11.49] 33.6 [9.85] 4.3

GROSS SYSTEMS PERFORMANCE DATA—B060

		ENTERING INDOOR AIR @ 80°F [26.7°C] dbE ①									
		wbE	71°F [21.7°C]			67°F [19.4°C]			63°F [17.2°C]		
		CFM [L/s]	2040 [963]	1850 [873]	1660 [783]	2040 [963]	1850 [873]	1660 [783]	2040 [963]	1850 [873]	1660 [783]
		DR ①	.21	.20	.18	.21	.20	.18	.21	.20	.18
OUTDOOR DRY BULB TEMPERATURE °F [°C]	75 [23.9]	Total BTUH [kW] Sens BTUH [kW] Power	73.6 [21.57] 42.2 [12.37] 4.0	72.3 [21.19] 40.3 [11.81] 3.9	71.0 [20.81] 38.4 [11.25] 3.9	68.5 [20.08] 49.1 [14.39] 3.9	67.3 [19.72] 46.9 [13.75] 3.8	66.1 [19.37] 44.7 [13.10] 3.8	65.9 [19.31] 53.3 [15.62] 3.8	64.7 [18.96] 50.9 [14.92] 3.8	63.5 [18.61] 48.5 [14.21] 3.7
	80 [26.7]	Total BTUH [kW] Sens BTUH [kW] Power	71.3 [20.90] 40.7 [11.93] 4.2	70.0 [20.51] 38.9 [11.40] 4.1	68.7 [20.13] 37.1 [10.87] 4.1	66.2 [19.40] 47.7 [13.98] 4.1	65.0 [19.05] 45.5 [13.33] 4.0	63.9 [18.73] 43.4 [12.72] 4.0	63.6 [18.64] 51.8 [15.18] 4.0	62.4 [18.29] 49.5 [14.51] 4.0	61.3 [17.97] 47.2 [13.83] 3.9
	85 [29.4]	Total BTUH [kW] Sens BTUH [kW] Power	69.3 [20.31] 39.5 [11.58] 4.4	68.1 [19.96] 37.8 [11.08] 4.4	66.8 [19.58] 36.0 [10.55] 4.3	64.2 [18.82] 46.5 [13.63] 4.3	63.1 [18.49] 44.4 [13.01] 4.3	61.9 [18.14] 42.3 [12.40] 4.2	61.6 [18.05] 50.6 [14.83] 4.2	60.5 [17.73] 48.3 [14.16] 4.2	59.4 [17.41] 46.1 [13.51] 4.1
	90 [32.2]	Total BTUH [kW] Sens BTUH [kW] Power	67.5 [19.78] 38.5 [11.28] 4.6	66.3 [19.43] 36.8 [10.79] 4.6	65.1 [19.08] 35.1 [10.29] 4.5	62.5 [18.32] 45.5 [13.33] 4.5	61.3 [17.97] 43.5 [12.75] 4.5	60.2 [17.64] 41.4 [12.13] 4.4	59.8 [17.53] 49.6 [14.54] 4.4	58.7 [17.20] 47.4 [13.89] 4.4	57.6 [16.88] 45.2 [13.25] 4.4
	95 [35]	Total BTUH [kW] Sens BTUH [kW] Power	65.8 [19.28] 37.7 [11.05] 4.8	64.7 [18.96] 36.0 [10.55] 4.8	63.5 [18.61] 34.3 [10.05] 4.7	60.8 [17.82] 44.6 [13.07] 4.7	59.7 [17.50] 42.6 [12.48] 4.7	58.6 [17.17] 40.7 [11.93] 4.6	58.1 [17.03] 48.8 [14.30] 4.6	57.1 [16.73] 46.6 [13.66] 4.6	56.0 [16.41] 44.4 [13.01] 4.6
	100 [37.8]	Total BTUH [kW] Sens BTUH [kW] Power	64.2 [18.82] 36.9 [10.81] 5.0	63.0 [18.46] 35.3 [10.35] 5.0	61.9 [18.14] 33.6 [9.85] 4.9	59.1 [17.32] 43.9 [12.87] 4.9	58.0 [17.00] 41.9 [12.28] 4.9	57.0 [16.71] 39.9 [11.69] 4.8	56.4 [16.53] 48.0 [14.07] 4.9	55.4 [16.24] 45.8 [13.42] 4.8	54.4 [15.94] 43.7 [12.81] 4.8
	105 [40.6]	Total BTUH [kW] Sens BTUH [kW] Power	62.4 [18.29] 36.1 [10.58] 5.2	61.3 [17.97] 34.5 [10.11] 5.2	60.1 [17.61] 32.9 [9.64] 5.2	57.3 [16.79] 43.1 [12.63] 5.1	56.3 [16.50] 41.2 [12.07] 5.1	55.3 [16.21] 39.2 [11.49] 5.1	54.6 [16.00] 47.2 [13.83] 5.1	53.7 [15.74] 45.1 [13.22] 5.0	52.7 [15.44] 43.0 [12.60] 5.0
	110 [43.3]	Total BTUH [kW] Sens BTUH [kW] Power	60.4 [17.70] 35.3 [10.35] 5.5	59.3 [17.38] 33.7 [9.88] 5.4	58.2 [17.06] 32.2 [9.44] 5.4	55.3 [16.21] 42.3 [12.40] 5.4	54.3 [15.91] 40.4 [11.84] 5.3	53.4 [15.65] 38.5 [11.28] 5.3	52.7 [15.44] 46.4 [13.60] 5.3	51.7 [15.15] 44.3 [12.98] 5.2	50.8 [14.89] 42.2 [12.37] 5.2
	115 [46.1]	Total BTUH [kW] Sens BTUH [kW] Power	58.1 [17.03] 34.4 [10.08] 5.7	57.1 [16.73] 32.8 [9.61] 5.6	56.0 [16.41] 31.3 [9.17] 5.6	53.0 [15.53] 41.3 [12.10] 5.6	52.1 [15.27] 39.5 [11.58] 5.5	51.1 [14.98] 37.6 [11.02] 5.5	50.4 [14.77] 45.4 [13.31] 5.5	49.5 [14.51] 43.4 [12.72] 5.4	48.6 [14.24] 41.4 [12.13] 5.4

DR —Depression ratio
dbE—Entering air dry bulb
wbE—Entering air wet bulb

Total —Total capacity x 1000 BTUH
Sens —Sensible capacity x 1000 BTUH
Power—KW input

NOTES: ① When the entering air dry bulb is other than 80°F [27°C], adjust the sensible capacity from the table by adding $[1.10 \times \text{CFM} \times (1 - \text{DR}) \times (\text{dbE} - 80)]$.

[] Designates Metric Conversions



SYSTEMS PERFORMANCE—RRRL- SERIES

GROSS SYSTEMS PERFORMANCE DATA—C024

		ENTERING INDOOR AIR @ 80°F [26.7°C] dbE ①									
wbE		71°F [21.7°C]			67°F [19.4°C]			63°F [17.2°C]			
CFM [L/s]		880 [415]	800 [378]	720 [340]	880 [415]	800 [378]	720 [340]	880 [415]	800 [378]	720 [340]	
DR ①		.15	.16	.19	.15	.16	.19	.15	.16	.19	
OUTDOOR DRY BULB TEMPERATURE °F [°C]	75 [23.9]	Total BTUH [kW] Sens BTUH [kW] Power	29.9 [8.76] 18.0 [5.28] 1.5	29.4 [8.62] 16.7 [4.89] 1.5	28.9 [8.47] 15.4 [4.51] 1.5	28.1 [8.24] 21.2 [6.21] 1.5	27.6 [8.09] 19.8 [5.80] 1.5	27.1 [7.94] 18.4 [5.39] 1.5	27.0 [7.91] 24.2 [7.09] 1.5	26.5 [7.77] 22.6 [6.62] 1.5	26.0 [7.62] 21.1 [6.18] 1.4
	80 [26.7]	Total BTUH [kW] Sens BTUH [kW] Power	29.1 [8.53] 17.5 [5.13] 1.6	28.6 [8.38] 16.2 [4.75] 1.6	28.0 [8.21] 14.9 [4.37] 1.6	27.3 [8.00] 20.7 [6.07] 1.6	26.8 [7.85] 19.3 [5.66] 1.6	26.3 [7.71] 17.9 [5.25] 1.6	26.1 [7.65] 23.6 [6.92] 1.5	25.6 [7.50] 22.0 [6.45] 1.5	25.2 [7.39] 20.6 [6.04] 1.5
	85 [29.4]	Total BTUH [kW] Sens BTUH [kW] Power	28.2 [8.26] 16.9 [4.95] 1.7	27.7 [8.12] 15.6 [4.57] 1.7	27.2 [7.97] 14.4 [4.22] 1.7	26.4 [7.74] 20.1 [5.89] 1.7	25.9 [7.59] 18.7 [5.48] 1.6	25.5 [7.47] 17.4 [5.10] 1.6	25.2 [7.39] 22.9 [6.71] 1.6	24.8 [7.27] 21.5 [6.30] 1.6	24.3 [7.12] 20.0 [5.86] 1.6
	90 [32.2]	Total BTUH [kW] Sens BTUH [kW] Power	27.3 [8.00] 16.3 [4.78] 1.8	26.8 [7.85] 15.1 [4.43] 1.8	26.3 [7.71] 13.9 [4.07] 1.7	25.5 [7.47] 19.6 [5.74] 1.7	25.1 [7.36] 18.3 [5.36] 1.7	24.6 [7.21] 17.0 [4.98] 1.7	24.3 [7.12] 22.4 [6.56] 1.7	23.9 [7.00] 21.0 [6.15] 1.7	23.5 [6.89] 19.6 [5.74] 1.7
	95 [35]	Total BTUH [kW] Sens BTUH [kW] Power	26.4 [7.74] 15.8 [4.63] 1.9	25.9 [7.59] 14.6 [4.28] 1.8	25.5 [7.47] 13.5 [3.96] 1.8	24.6 [7.21] 19.0 [5.57] 1.8	24.2 [7.09] 17.8 [5.22] 1.8	23.7 [6.95] 16.5 [4.84] 1.8	23.4 [6.86] 21.9 [6.42] 1.8	23.0 [6.74] 20.5 [6.01] 1.8	22.6 [6.62] 19.2 [5.63] 1.8
	100 [37.8]	Total BTUH [kW] Sens BTUH [kW] Power	25.5 [7.47] 15.3 [4.48] 2.0	25.0 [7.33] 14.1 [4.13] 1.9	24.6 [7.21] 13.1 [3.84] 1.9	23.7 [6.95] 18.6 [5.45] 1.9	23.3 [6.83] 17.4 [5.10] 1.9	22.9 [6.71] 16.2 [4.75] 1.9	22.5 [6.59] 21.5 [6.30] 1.9	22.1 [6.48] 20.1 [5.89] 1.9	21.7 [6.36] 18.8 [5.51] 1.8
	105 [40.6]	Total BTUH [kW] Sens BTUH [kW] Power	24.6 [7.21] 14.9 [4.37] 2.0	24.2 [7.09] 13.8 [4.04] 2.0	23.7 [6.95] 12.7 [3.72] 2.0	22.8 [6.68] 18.2 [5.33] 2.0	22.4 [6.56] 17.0 [4.98] 2.0	22.0 [6.45] 15.8 [4.63] 2.0	21.6 [6.33] 21.0 [6.15] 2.0	21.2 [6.21] 19.7 [5.77] 2.0	20.8 [6.10] 18.4 [5.39] 1.9
	110 [43.3]	Total BTUH [kW] Sens BTUH [kW] Power	23.7 [6.95] 14.5 [4.25] 2.1	23.2 [6.80] 13.4 [3.93] 2.1	22.8 [6.68] 12.4 [3.63] 2.1	21.9 [6.42] 17.8 [5.22] 2.1	21.5 [6.30] 16.6 [4.86] 2.1	21.1 [6.18] 15.4 [4.51] 2.1	20.7 [6.07] 20.6 [6.04] 2.1	20.3 [5.95] 19.3 [5.66] 2.1	19.9 [5.83] 18.0 [5.28] 2.0
	115 [46.1]	Total BTUH [kW] Sens BTUH [kW] Power	22.7 [6.65] 14.1 [4.13] 2.3	22.3 [6.54] 13.1 [3.84] 2.2	21.9 [6.42] 12.1 [3.55] 2.2	20.9 [6.13] 17.4 [5.10] 2.2	20.6 [6.04] 16.3 [4.78] 2.2	20.2 [5.92] 15.2 [4.45] 2.2	19.7 [5.77] 19.7 [5.77] 2.2	19.4 [5.69] 19.1 [5.60] 2.2	19.0 [5.57] 17.8 [5.22] 2.1

GROSS SYSTEMS PERFORMANCE DATA—C036

		ENTERING INDOOR AIR @ 80°F [26.7°C] dbE ①									
wbE		71°F [21.7°C]			67°F [19.4°C]			63°F [17.2°C]			
CFM [L/s]		1320 [623]	1200 [566]	1080 [510]	1320 [623]	1200 [566]	1080 [510]	1320 [623]	1200 [566]	1080 [510]	
DR ①		.07	.09	.11	.07	.09	.11	.07	.09	.11	
OUTDOOR DRY BULB TEMPERATURE °F [°C]	75 [23.9]	Total BTUH [kW] Sens BTUH [kW] Power	45.1 [13.22] 28.8 [8.44] 2.3	44.3 [12.98] 26.7 [7.83] 2.3	43.5 [12.75] 24.7 [7.24] 2.2	42.4 [12.43] 33.0 [9.67] 2.2	41.6 [12.19] 30.7 [9.00] 2.2	40.9 [11.99] 28.6 [8.38] 2.2	39.8 [11.66] 35.3 [10.35] 2.1	39.1 [11.46] 33.0 [9.67] 2.1	38.4 [11.25] 30.8 [9.03] 2.1
	80 [26.7]	Total BTUH [kW] Sens BTUH [kW] Power	44.0 [12.90] 28.1 [8.24] 2.4	43.2 [12.66] 26.0 [7.62] 2.4	42.4 [12.43] 24.0 [7.03] 2.4	41.3 [12.10] 32.2 [9.44] 2.3	40.5 [11.87] 30.0 [8.79] 2.3	39.8 [11.66] 27.9 [8.18] 2.3	38.7 [11.34] 34.6 [10.14] 2.2	38.0 [11.14] 32.4 [9.50] 2.2	37.3 [10.93] 30.2 [8.85] 2.2
	85 [29.4]	Total BTUH [kW] Sens BTUH [kW] Power	42.8 [12.54] 27.4 [8.03] 2.5	42.1 [12.34] 25.5 [7.47] 2.5	41.3 [12.10] 23.5 [6.89] 2.5	40.1 [11.75] 31.6 [9.26] 2.4	39.4 [11.55] 29.5 [8.65] 2.4	38.7 [11.34] 27.5 [8.06] 2.4	37.5 [10.99] 33.9 [9.94] 2.4	36.8 [10.79] 31.7 [9.29] 2.4	36.1 [10.58] 29.6 [8.67] 2.3
	90 [32.2]	Total BTUH [kW] Sens BTUH [kW] Power	41.6 [12.19] 26.7 [7.83] 2.7	40.8 [11.96] 24.7 [7.24] 2.6	40.1 [11.75] 22.9 [6.71] 2.6	38.8 [11.37] 30.8 [9.03] 2.6	38.1 [11.17] 28.7 [8.41] 2.6	37.4 [10.96] 26.7 [7.83] 2.5	36.2 [10.61] 33.2 [9.73] 2.5	35.6 [10.43] 31.1 [9.11] 2.5	34.9 [10.23] 29.0 [8.50] 2.5
	95 [35]	Total BTUH [kW] Sens BTUH [kW] Power	40.2 [11.78] 26.0 [7.62] 2.8	39.5 [11.58] 24.1 [7.06] 2.8	38.8 [11.37] 22.3 [6.54] 2.8	37.5 [10.99] 30.1 [8.82] 2.7	36.8 [10.79] 28.1 [8.24] 2.7	36.1 [10.58] 26.1 [7.65] 2.7	34.9 [10.23] 32.4 [9.50] 2.7	34.2 [10.02] 30.3 [8.88] 2.6	33.6 [9.85] 28.3 [8.29] 2.6
	100 [37.8]	Total BTUH [kW] Sens BTUH [kW] Power	38.8 [11.37] 25.2 [7.39] 3.0	38.1 [11.17] 23.4 [6.86] 2.9	37.4 [10.96] 21.6 [6.33] 2.9	36.1 [10.58] 29.4 [8.62] 2.9	35.4 [10.37] 27.4 [8.03] 2.9	34.8 [10.20] 25.5 [7.47] 2.8	33.5 [9.82] 31.7 [9.29] 2.8	32.9 [9.64] 29.7 [8.70] 2.8	32.3 [9.47] 27.7 [8.12] 2.8
	105 [40.6]	Total BTUH [kW] Sens BTUH [kW] Power	37.3 [10.93] 24.5 [7.18] 3.1	36.6 [10.73] 22.7 [6.65] 3.1	36.0 [10.55] 21.1 [6.18] 3.1	34.6 [10.14] 28.7 [8.41] 3.0	34.0 [9.96] 26.8 [7.85] 3.0	33.3 [9.76] 24.9 [7.30] 3.0	32.0 [9.38] 31.0 [9.09] 3.0	31.4 [9.20] 29.0 [8.50] 2.9	30.8 [9.03] 27.1 [7.94] 2.9
	110 [43.3]	Total BTUH [kW] Sens BTUH [kW] Power	35.8 [10.49] 23.8 [6.98] 3.3	35.1 [10.29] 22.0 [6.45] 3.3	34.5 [10.11] 20.4 [5.98] 3.2	33.0 [9.67] 27.8 [8.15] 3.2	32.4 [9.50] 26.0 [7.62] 3.2	31.8 [9.32] 24.2 [7.09] 3.2	30.4 [8.91] 30.1 [8.82] 3.1	29.9 [8.76] 28.3 [8.29] 3.1	29.3 [8.59] 26.4 [7.74] 3.1
	115 [46.1]	Total BTUH [kW] Sens BTUH [kW] Power	34.1 [9.99] 22.9 [6.71] 3.5	33.5 [9.82] 21.3 [6.24] 3.4	32.9 [9.64] 19.7 [5.77] 3.4	31.4 [9.20] 27.1 [7.94] 3.4	30.8 [9.03] 25.3 [7.41] 3.4	30.3 [8.88] 23.6 [6.92] 3.3	28.8 [8.44] 28.8 [8.44] 3.3	28.3 [8.29] 27.6 [8.09] 3.3	27.8 [8.15] 25.8 [7.56] 3.3

DR —Depression ratio
dbE—Entering air dry bulb
wbE—Entering air wet bulb

Total —Total capacity x 1000 BTUH
Sens —Sensible capacity x 1000 BTUH
Power—KW input

NOTES: ① When the entering air dry bulb is other than 80°F [27°C], adjust the sensible capacity from the table by adding $[1.10 \times \text{CFM} \times (1 - \text{DR}) \times (\text{dbE} - 80)]$.

[] Designates Metric Conversions



GROSS SYSTEMS PERFORMANCE DATA—C048

		ENTERING INDOOR AIR @ 80°F [26.7°C] dbE ①									
wbE		71°F [21.7°C]			67°F [19.4°C]			63°F [17.2°C]			
CFM [L/s]		1760 [831]	1600 [755]	1440 [680]	1760 [831]	1600 [755]	1440 [680]	1760 [831]	1600 [755]	1440 [680]	
DR ①		.12	.14	.16	.12	.14	.16	.12	.14	.16	
OUTDOOR DRY BULB TEMPERATURE °F [°C]	75 [23.9]	Total BTUH [kW] Sens BTUH [kW] Power	59.8 [17.53] 36.4 [10.67] 3.1	58.7 [17.20] 33.7 [9.88] 3.1	57.6 [16.88] 31.1 [9.11] 3.0	55.8 [16.35] 42.0 [12.31] 3.0	54.8 [16.06] 39.1 [11.46] 3.0	53.8 [15.77] 36.3 [10.64] 2.9	52.4 [15.36] 46.3 [13.57] 2.9	51.4 [15.06] 43.2 [12.66] 2.9	50.5 [14.80] 40.3 [11.81] 2.9
	80 [26.7]	Total BTUH [kW] Sens BTUH [kW] Power	58.3 [17.09] 35.7 [10.46] 3.2	57.3 [16.79] 33.1 [9.70] 3.2	56.2 [16.47] 30.5 [8.94] 3.2	54.3 [15.91] 41.2 [12.07] 3.1	53.3 [15.62] 38.4 [11.25] 3.1	52.4 [15.36] 35.7 [10.46] 3.1	50.9 [14.92] 45.4 [13.31] 3.1	50.0 [14.65] 42.5 [12.46] 3.0	49.1 [14.39] 39.7 [11.63] 3.0
	85 [29.4]	Total BTUH [kW] Sens BTUH [kW] Power	56.8 [16.65] 34.9 [10.23] 3.4	55.8 [16.35] 32.3 [9.47] 3.4	54.7 [16.03] 29.7 [8.70] 3.3	52.8 [15.47] 40.4 [11.84] 3.3	51.8 [15.18] 37.6 [11.02] 3.3	50.9 [14.92] 35.0 [10.26] 3.2	49.4 [14.48] 44.7 [13.10] 3.2	48.5 [14.21] 41.8 [12.25] 3.2	47.6 [13.95] 39.0 [11.43] 3.2
	90 [32.2]	Total BTUH [kW] Sens BTUH [kW] Power	55.2 [16.18] 34.0 [9.96] 3.6	54.2 [15.88] 31.5 [9.23] 3.5	53.2 [15.59] 29.1 [8.53] 3.5	51.2 [15.01] 39.6 [11.61] 3.5	50.3 [14.74] 36.9 [10.81] 3.4	49.4 [14.48] 34.3 [10.05] 3.4	47.8 [14.01] 43.9 [12.87] 3.4	46.9 [13.75] 41.0 [12.02] 3.3	46.1 [13.51] 38.3 [11.22] 3.3
	95 [35]	Total BTUH [kW] Sens BTUH [kW] Power	53.5 [15.68] 33.2 [9.73] 3.7	52.6 [15.42] 30.8 [9.03] 3.7	51.6 [15.12] 28.4 [8.32] 3.7	49.6 [14.54] 38.8 [11.37] 3.6	48.7 [14.27] 36.2 [10.61] 3.6	47.8 [14.01] 33.7 [9.88] 3.6	46.1 [13.51] 42.9 [12.57] 3.6	45.3 [13.28] 40.2 [11.78] 3.5	44.5 [13.04] 37.6 [11.02] 3.5
	100 [37.8]	Total BTUH [kW] Sens BTUH [kW] Power	51.8 [15.18] 32.2 [9.44] 3.9	50.9 [14.92] 29.9 [8.76] 3.9	50.0 [14.65] 27.6 [8.09] 3.8	47.8 [14.01] 37.9 [11.11] 3.8	47.0 [13.77] 35.4 [10.37] 3.8	46.1 [13.51] 32.9 [9.64] 3.8	44.4 [13.01] 42.1 [12.34] 3.7	43.6 [12.78] 39.4 [11.55] 3.7	42.9 [12.57] 36.9 [10.81] 3.7
	105 [40.6]	Total BTUH [kW] Sens BTUH [kW] Power	50.1 [14.68] 31.4 [9.20] 4.1	49.2 [14.42] 29.1 [8.53] 4.1	48.3 [14.16] 26.9 [7.88] 4.0	46.1 [13.51] 37.1 [10.87] 4.0	45.3 [13.28] 34.6 [10.14] 4.0	44.4 [13.01] 32.1 [9.41] 3.9	42.7 [12.51] 41.2 [12.07] 3.9	41.9 [12.28] 38.6 [11.31] 3.9	41.2 [12.07] 36.1 [10.58] 3.9
	110 [43.3]	Total BTUH [kW] Sens BTUH [kW] Power	48.2 [14.13] 30.5 [8.94] 4.3	47.4 [13.89] 28.3 [8.29] 4.3	46.5 [13.63] 26.1 [7.65] 4.2	44.3 [12.98] 36.1 [10.58] 4.2	43.5 [12.75] 33.7 [9.88] 4.2	42.7 [12.51] 31.4 [9.20] 4.1	40.9 [11.99] 40.4 [11.84] 4.1	40.1 [11.75] 37.8 [11.08] 4.1	39.4 [11.55] 35.4 [10.37] 4.1
	115 [46.1]	Total BTUH [kW] Sens BTUH [kW] Power	46.4 [13.60] 29.5 [8.65] 4.5	45.5 [13.33] 27.3 [8.00] 4.5	44.7 [13.10] 25.3 [7.41] 4.4	42.4 [12.43] 35.2 [10.32] 4.4	41.6 [12.19] 32.8 [9.61] 4.4	40.9 [11.99] 30.6 [8.97] 4.4	39.0 [11.43] 39.0 [11.43] 4.3	38.3 [11.22] 36.9 [10.81] 4.3	37.6 [11.02] 34.5 [10.11] 4.3

GROSS SYSTEMS PERFORMANCE DATA—C060

		ENTERING INDOOR AIR @ 80°F [26.7°C] dbE ①									
wbE		71°F [21.7°C]			67°F [19.4°C]			63°F [17.2°C]			
CFM [L/s]		2040 [963]	1850 [873]	1660 [783]	2040 [963]	1850 [873]	1660 [783]	2040 [963]	1850 [873]	1660 [783]	
DR ①		.07	.09	.12	.07	.09	.12	.07	.09	.12	
OUTDOOR DRY BULB TEMPERATURE °F [°C]	75 [23.9]	Total BTUH [kW] Sens BTUH [kW] Power	73.1 [21.42] 44.3 [12.98] 4.1	71.8 [21.04] 41.0 [12.02] 4.0	70.5 [20.66] 37.8 [11.08] 4.0	68.9 [20.19] 51.6 [15.12] 4.0	67.6 [19.81] 47.9 [14.04] 3.9	66.4 [19.46] 44.5 [13.04] 3.9	65.1 [19.08] 56.8 [16.65] 3.8	63.9 [18.73] 53.0 [15.53] 3.8	62.7 [18.38] 49.3 [14.45] 3.8
	80 [26.7]	Total BTUH [kW] Sens BTUH [kW] Power	71.5 [20.95] 43.7 [12.81] 4.3	70.2 [20.57] 40.4 [11.84] 4.2	68.9 [20.19] 37.2 [10.90] 4.2	67.3 [19.72] 50.9 [14.92] 4.1	66.1 [19.37] 47.4 [13.89] 4.1	64.8 [18.99] 43.9 [12.87] 4.1	63.5 [18.61] 56.2 [16.47] 4.0	62.3 [18.26] 52.4 [15.36] 4.0	61.1 [17.91] 48.7 [14.27] 3.9
	85 [29.4]	Total BTUH [kW] Sens BTUH [kW] Power	69.8 [20.46] 43.0 [12.60] 4.4	68.5 [20.08] 39.7 [11.63] 4.4	67.2 [19.69] 36.6 [10.73] 4.4	65.5 [19.20] 50.1 [14.68] 4.3	64.3 [18.84] 46.6 [13.66] 4.3	63.1 [18.49] 43.2 [12.66] 4.2	61.7 [18.08] 55.3 [16.21] 4.2	60.6 [17.76] 51.7 [15.15] 4.2	59.4 [17.41] 48.1 [14.10] 4.1
	90 [32.2]	Total BTUH [kW] Sens BTUH [kW] Power	67.9 [19.90] 42.0 [12.31] 4.6	66.6 [19.52] 38.8 [11.37] 4.6	65.4 [19.17] 35.8 [10.49] 4.6	63.6 [18.64] 49.1 [14.39] 4.5	62.5 [18.32] 45.8 [13.42] 4.5	61.3 [17.97] 42.5 [12.46] 4.4	59.8 [17.53] 54.4 [15.94] 4.4	58.7 [17.20] 50.8 [14.89] 4.4	57.6 [16.88] 47.3 [13.86] 4.3
	95 [35]	Total BTUH [kW] Sens BTUH [kW] Power	65.8 [19.28] 40.9 [11.99] 4.9	64.6 [18.93] 37.8 [11.08] 4.8	63.4 [18.58] 34.8 [10.20] 4.8	61.6 [18.05] 48.1 [14.10] 4.7	60.4 [17.70] 44.7 [13.10] 4.7	59.3 [17.38] 41.5 [12.16] 4.6	57.7 [16.91] 53.2 [15.59] 4.6	56.7 [16.62] 49.8 [14.59] 4.6	55.6 [16.29] 46.4 [13.60] 4.5
	100 [37.8]	Total BTUH [kW] Sens BTUH [kW] Power	63.6 [18.64] 39.6 [11.61] 5.1	62.4 [18.29] 36.6 [10.73] 5.0	61.3 [17.97] 33.8 [9.91] 5.0	59.4 [17.41] 46.8 [13.72] 5.0	58.3 [17.09] 43.6 [12.78] 4.9	57.2 [16.76] 40.5 [11.87] 4.9	55.5 [16.27] 52.0 [15.24] 4.8	54.5 [15.97] 48.6 [14.24] 4.8	53.5 [15.68] 45.3 [13.28] 4.7
	105 [40.6]	Total BTUH [kW] Sens BTUH [kW] Power	61.2 [17.94] 38.0 [11.14] 5.3	60.1 [17.61] 35.2 [10.32] 5.3	59.0 [17.29] 32.5 [9.52] 5.2	57.0 [16.71] 45.3 [13.28] 5.2	55.9 [16.38] 42.1 [12.34] 5.1	54.9 [16.09] 39.1 [11.46] 5.1	53.1 [15.56] 50.5 [14.80] 5.1	52.2 [15.30] 47.3 [13.86] 5.0	51.2 [15.01] 44.1 [12.92] 5.0
	110 [43.3]	Total BTUH [kW] Sens BTUH [kW] Power	58.7 [17.20] 36.5 [10.70] 5.6	57.6 [16.88] 33.7 [9.88] 5.5	56.5 [16.56] 31.0 [9.09] 5.5	54.4 [15.94] 43.6 [12.78] 5.4	53.4 [15.65] 40.6 [11.90] 5.4	52.4 [15.36] 37.7 [11.05] 5.3	50.6 [14.83] 48.8 [14.30] 5.3	49.7 [14.57] 45.7 [13.39] 5.3	48.7 [14.27] 42.6 [12.48] 5.2
	115 [46.1]	Total BTUH [kW] Sens BTUH [kW] Power	56.0 [16.41] 34.7 [10.17] 5.8	55.0 [16.12] 32.1 [9.41] 5.8	53.9 [15.80] 29.5 [8.65] 5.7	51.8 [15.18] 41.8 [12.25] 5.7	50.8 [14.89] 38.9 [11.40] 5.6	49.9 [14.62] 36.2 [10.61] 5.6	47.9 [14.04] 47.1 [13.80] 5.6	47.0 [13.77] 44.0 [12.90] 5.5	46.2 [13.54] 41.1 [12.05] 5.5

DR —Depression ratio
dbE—Entering air dry bulb
wbE—Entering air wet bulb

Total —Total capacity x 1000 BTUH
Sens —Sensible capacity x 1000 BTUH
Power—kW input

NOTES: ① When the entering air dry bulb is other than 80°F [27°C], adjust the sensible capacity from the table by adding $[1.10 \times \text{CFM} \times (1 - \text{DR}) \times (\text{dbE} - 80)]$.

[] Designates Metric Conversions



INDOOR AIRFLOW PERFORMANCE—208 VOLTS

Nominal Cooling Capacity Tons [kW]	Motor Speed from Factory		Heating Input BTU/HR [kW]	Blower Size/ Motor HP [W] & # of Speeds	Motor Speed	External Static Pressure—Inches W.C. [kPa] Side Discharge—Wet Coil						
	Cool	Heat				0.1 [0.02]	0.2 [0.05]	0.3 [0.07]	0.4 [0.10]	0.5 [0.12]	0.6 [0.15]	0.7 [0.17]
2.0 [7.03]	High	Low	40,000 [11.72]	9 x 7 Blower 1/4 HP [186] 2 Speed (PSC Motor)	Low	CFM [l/s]	675 [319]	634 [299]	602 [284]	560 [264]	505 [238]	435 [205]
		High	60,000 [17.58] 80,000 [23.45]			RPM	695	870	905	940	980	1020
2.5 [8.79]	Low	Low	All Inputs 40,000 [11.72] 60,000 [17.58] 80,000 [23.45] 100,000 [29.31]	10 x 9 Blower 1/2 HP [372] 3 Speed (PSC Motor)	Low	CFM [l/s]	1076 [508]	1032 [490]	996 [470]	950 [448]	896 [423]	832 [393]
		Med.				RPM	730	820	865	905	940	975
3.0 [10.55]	Med.	Low	All Inputs 40,000 [11.72] 60,000 [17.58] 80,000 [23.45] 100,000 [29.31]	10 x 9 Blower 1/2 HP [372] 3 Speed (PSC Motor)	Med.	CFM [l/s]	1222 [577]	1179 [556]	1162 [548]	1137 [537]	1097 [518]	1033 [488]
		High				RPM	765	855	890	920	960	995
3.5 [12.31]	High	Low	All Inputs 40,000 [11.72] 60,000 [17.58] 80,000 [23.45] 100,000 [29.31]	10 x 9 Blower 1/2 HP [372] 3 Speed (PSC Motor)	High	CFM [l/s]	1514 [715]	1415 [668]	1370 [647]	1322 [624]	1266 [597]	1197 [565]
		Med.				RPM	895	965	985	1005	1025	1045
4.0 [14.07]	High	Low	All Inputs 40,000 [11.72] 60,000 [17.58] 80,000 [23.45] 100,000 [29.31]	10 x 9 Blower 3/4 HP [559] 3 Speed (PSC Motor)	Low	CFM [l/s]	1204 [568]	1191 [562]	1171 [553]	1143 [539]	1107 [522]	1065 [503]
		High				RPM	734	886	923	959	968	1016
5.0 [17.59]	High	Low	All Inputs 40,000 [11.72] 60,000 [17.58] 80,000 [23.45] 100,000 [29.31]	12 x 9 Blower 1 HP [746] 3 Speed (X13 Motor)	Med.	CFM [l/s]	1674 [790]	1566 [739]	1511 [713]	1451 [685]	1384 [653]	1305 [616]
		High				RPM	997	1040	1058	1076	1088	1100
5.0 [17.59]	High	Low	All Inputs 40,000 [11.72] 60,000 [17.58] 80,000 [23.45] 100,000 [29.31]	12 x 9 Blower 1 HP [746] 3 Speed (X13 Motor)	High	CFM [l/s]	1843 [870]	1693 [799]	1627 [768]	1560 [736]	1485 [701]	1398 [660]
		Med. (Tap 1)				RPM	1085	1102	1110	1118	1126	1134
5.0 [17.59]	High	Low	All Inputs 40,000 [11.72] 60,000 [17.58] 80,000 [23.45] 100,000 [29.31]	12 x 9 Blower 1 HP [746] 3 Speed (X13 Motor)	Heat Dedicated (Tap 1)	CFM [l/s]	1418 [669]	1352 [638]	1307 [617]	1270 [599]	1221 [576]	1180 [557]
		Med. (Tap 2)				RPM	774	829	860	892	922	955
5.0 [17.59]	High	Low	All Inputs 40,000 [11.72] 60,000 [17.58] 80,000 [23.45] 100,000 [29.31]	12 x 9 Blower 1 HP [746] 3 Speed (X13 Motor)	High (Tap 3)	CFM [l/s]	1858 [877]	1782 [841]	1752 [827]	1714 [809]	1678 [792]	1640 [774]
		Med. (Tap 3)				RPM	944	994	1019	1041	1072	1089
5.0 [17.59]	High	Low	All Inputs 40,000 [11.72] 60,000 [17.58] 80,000 [23.45] 100,000 [29.31]	12 x 9 Blower 1 HP [746] 3 Speed (X13 Motor)	High (Tap 3)	CFM [l/s]	2017 [952]	1949 [920]	1909 [901]	1879 [887]	1843 [870]	1792 [846]
		Med. (Tap 3)				RPM	1018	1070	1076	1112	1124	1147
		Low				Watts	690	711	723	735	741	742

NOTES: 5 ton High cooling speed must be changed to low cool to achieve AHRI performance.

[] Designates Metric Conversions



INDOOR AIRFLOW PERFORMANCE—208 VOLTS (continued)

DOWN DISCHARGE PRESSURE DROP (ADD TO EXTERNAL STATIC PRESSURE)									
CFM [L/s]	600 [283]	800 [378]	1000 [472]	1200 [556]	1440 [661]	1600 [755]	1800 [850]	2000 [944]	
Pressure Drop—Includes W.C. [kPa]	.00	.02 [.005]	.05 [.012]	.07 [.017]	.1 [.025]	.12 [.030]	.15 [.037]	.17 [.042]	

[] Designates Metric Conversions



INDOOR AIRFLOW PERFORMANCE—230 VOLTS

Nominal Cooling Capacity Tons [kW]	Motor Speed from Factory		Heating Input BTU/HR [kW]	Blower Size/ Motor HP [W] & # of Speeds	Motor Speed	External Static Pressure—Inches W.C. [kPa] Side Discharge—Wet Coil							
	Cool	Heat				0.1 [0.02]	0.2 [0.05]	0.3 [0.07]	0.4 [0.10]	0.5 [0.12]	0.6 [0.15]	0.7 [0.17]	
2.0 [7.03]	High	Low	40,000 [11.72]	9 x 7 Blower 1/4 HP [186] 2 Speed (PSC Motor)	Low	CFM [l/s]	771 [364]	751 [354]	725 [342]	691 [326]	654 [304]	584 [276]	546 [258]
						RPM	825	870	910	950	985	1010	1030
	High	High	60,000 [17.58] 80,000 [23.45]	CFM [l/s]	946 [446]	922 [435]	882 [416]	830 [392]	769 [363]	701 [331]	630 [298]	546 [258]	
2.5 [8.79]	Low	Low	All Inputs	10 x 9 Blower 1/2 HP [372] 3 Speed (PSC Motor)	Low	CFM [l/s]	1206 [569]	1182 [558]	1157 [546]	1128 [532]	1091 [515]	1044 [493]	983 [464]
						RPM	760	815	870	910	950	975	1000
	Med.	Low	40,000 [11.72] 60,000 [17.58] 80,000 [23.45] 100,000 [29.31]	CFM [l/s]	1411 [666]	1368 [646]	1327 [626]	1285 [606]	1238 [584]	1183 [558]	1116 [527]	1035	
3.0 [10.55]	Med.	Low	All Inputs	10 x 9 Blower 1/2 HP [372] 3 Speed (PSC Motor)	Med.	RPM	865	900	935	970	1000	1020	1035
						Watts	498	481	464	447	430	411	391
	High	Low	60,000 [17.58] 80,000 [23.45] 100,000 [29.31]	CFM [l/s]	1641 [774]	1577 [744]	1515 [715]	1455 [687]	1393 [657]	1329 [627]	1262 [596]	1080	
3.5 [12.31]	High	Low	All Inputs	10 x 9 Blower 1/2 HP [372] 3 Speed (PSC Motor)	High	RPM	980	1000	1020	1035	1050	1065	1080
						Watts	589	565	543	523	503	481	456
	High	Low	60,000 [17.58] 80,000 [23.45] 100,000 [29.31]	CFM [l/s]	1412 [668]	1395 [658]	1371 [647]	1339 [632]	1296 [612]	1242 [586]	1176 [555]	1057	
4.0 [14.07]	High	Low	All Inputs	10 x 9 Blower 3/4 HP [559] 3 Speed (PSC Motor)	Med.	RPM	859	905	951	981	1011	1034	1057
						Watts	557	530	506	483	461	437	409
	High	Low	60,000 [17.58] 80,000 [23.45] 100,000 [29.31]	CFM [l/s]	1793 [846]	1731 [817]	1665 [786]	1594 [752]	1519 [717]	1440 [680]	1356 [640]	1119	
5.0 [17.59]	High	Med. (Tap 1)	100,000 [29.31]	12 x 9 Blower 1 HP [746] 3 Speed (X13 Motor)	High	RPM	1053	1067	1080	1091	1101	1110	1119
						Watts	667	637	606	574	543	512	483
	High	Med. (Tap 3)	60,000 [17.58] 80,000 [23.45] 100,000 [29.31]	CFM [l/s]	1869 [892]	1826 [862]	1753 [827]	1672 [789]	1586 [749]	1499 [707]	1413 [667]	1144	
5.0 [17.59]	High	Med. (Tap 1)	100,000 [29.31]	12 x 9 Blower 1 HP [746] 3 Speed (X13 Motor)	High	RPM	1110	1117	1124	1129	1133	1139	1144
						Watts	736	715	683	646	608	574	551
	High	Med. (Tap 3)	60,000 [17.58] 80,000 [23.45] 100,000 [29.31]	CFM [l/s]	1423 [672]	1390 [656]	1357 [640]	1311 [619]	1277 [603]	1233 [582]	1192 [563]	958	
5.0 [17.59]	High	Med. (Tap 1)	100,000 [29.31]	12 x 9 Blower 1 HP [746] 3 Speed (X13 Motor)	High	RPM	776	796	830	861	895	927	958
						Watts	272	278	292	300	315	326	337
	High	Med. (Tap 3)	60,000 [17.58] 80,000 [23.45] 100,000 [29.31]	CFM [l/s]	1872 [883]	1847 [872]	1808 [853]	1772 [836]	1743 [823]	1703 [804]	1670 [788]	1110	
5.0 [17.59]	High	Med. (Tap 1)	100,000 [29.31]	12 x 9 Blower 1 HP [746] 3 Speed (X13 Motor)	High	RPM	956	973	1010	1023	1057	1085	1110
						Watts	562	572	584	598	613	622	636
	High	Med. (Tap 3)	60,000 [17.58] 80,000 [23.45] 100,000 [29.31]	CFM [l/s]	2046 [966]	2010 [949]	1980 [934]	1942 [917]	1904 [899]	1867 [881]	1822 [860]	1171	
5.0 [17.59]	High	Med. (Tap 1)	100,000 [29.31]	12 x 9 Blower 1 HP [746] 3 Speed (X13 Motor)	High	RPM	1035	1046	1079	1086	1114	1141	1171
						Watts	721	731	743	754	770	777	770

NOTES: 5 ton High cooling speed must be changed to low cool to achieve AHRI performance.

[] Designates Metric Conversions



INDOOR AIRFLOW PERFORMANCE—208 VOLTS

Nominal Cooling Capacity Tons [kW]	Motor Speed from Factory		Heating Input BTU/HR [kW]	Blower Size/ Motor HP [W] & # of Speeds	Motor Speed	External Static Pressure—Inches W.C. [kPa] Side Discharge—Dry Coil								
	Cool	Heat				0.1 [0.02]	0.2 [0.05]	0.3 [0.07]	0.4 [1.10]	0.5 [1.12]	0.6 [1.15]	0.7 [1.17]	0.8 [1.20]	
2.0 [7.03]	High Cool (Tap 3)	Heat (Tap 1)	All Inputs 40,000 [11.72] 60,000 [17.58] 80,000 [23.45]	9 x 7 Blower 1/3 HP [249 W] 3 Speed (X13 Motor)	Heat Dedicated (Tap 1)	CFM [l/s]	821 [387]	799 [377]	775 [366]	742 [350]	706 [333]	681 [321]	641 [303]	611 [288]
						RPM	878	903	953	996	1032	1075	1119	1176
						Watts	131	134	142	145	147	154	156	161
2.5 [8.79]	High Cool (Tap 3)	Heat (Tap 1)	All Inputs 40,000 [11.72] 60,000 [17.58] 80,000 [23.45] 100,000 [29.31]	10 x 9 Blower 1/2 HP [372 W] 3 Speed (X13 Motor)	Low Cool (Tap 2)	CFM [l/s]	843 [398]	820 [387]	786 [371]	760 [359]	726 [343]	699 [330]	662 [312]	608 [287]
						RPM	896	924	961	1015	1045	1092	1125	1172
						Watts	141	144	147	155	157	163	165	164
3.0 [10.55]	High Cool (Tap 3)	Heat (Tap 1)	All Inputs 40,000 [11.72] 60,000 [17.58] 80,000 [23.45] 100,000 [29.31]	10 x 9 Blower 1/2 HP [372 W] 3 Speed (X13 Motor)	High Cool (Tap 3)	CFM [l/s]	896 [423]	884 [417]	847 [400]	825 [389]	789 [372]	752 [355]	720 [340]	642 [303]
						RPM	935	966	1008	1047	1084	1118	1154	1176
						Watts	165	171	175	182	184	186	189	174
3.5 [12.31]	High Cool (Tap 3)	Heat (Tap 1)	All Inputs 40,000 [11.72] 60,000 [17.58] 80,000 [23.45] 100,000 [29.31]	10 x 9 Blower 1/2 HP [372 W] 3 Speed (X13 Motor)	Heat Dedicated (Tap 1)	CFM [l/s]	1153 [544]	1126 [531]	1087 [513]	1042 [492]	1002 [473]	966 [456]	903 [426]	856 [404]
						RPM	866	887	930	966	1010	1038	1082	1121
						Watts	207	210	220	226	234	241	246	251
3.5 [12.31]	High Cool (Tap 3)	Heat (Tap 1)	All Inputs 40,000 [11.72] 60,000 [17.58] 80,000 [23.45] 100,000 [29.31]	10 x 9 Blower 1/2 HP [372 W] 3 Speed (X13 Motor)	Low Cool (Tap 2)	CFM [l/s]	1030 [486]	1010 [477]	967 [456]	922 [435]	868 [410]	825 [389]	763 [360]	709 [335]
						RPM	794	829	868	912	956	1002	1040	1093
						Watts	155	164	169	178	183	192	195	203
3.5 [12.31]	High Cool (Tap 3)	Heat (Tap 1)	All Inputs 40,000 [11.72] 60,000 [17.58] 80,000 [23.45] 100,000 [29.31]	10 x 9 Blower 1/2 HP [372 W] 3 Speed (X13 Motor)	High Cool (Tap 3)	CFM [l/s]	1242 [586]	1213 [572]	1173 [554]	1132 [534]	1086 [513]	1044 [493]	1003 [473]	952 [449]
						RPM	912	934	972	1012	1055	1081	1109	1146
						Watts	249	252	262	271	275	282	283	288
3.5 [12.31]	High Cool (Tap 3)	Heat (Tap 1)	All Inputs 40,000 [11.72] 60,000 [17.58] 80,000 [23.45] 100,000 [29.31]	10 x 9 Blower 1/2 HP [372 W] 3 Speed (X13 Motor)	Heat Dedicated (Tap 1)	CFM [l/s]	1153 [544]	1126 [531]	1087 [513]	1042 [492]	1002 [473]	966 [456]	903 [426]	856 [404]
						RPM	866	887	930	966	1010	1038	1082	1121
						Watts	207	210	220	226	234	241	246	251
3.5 [12.31]	High Cool (Tap 3)	Heat (Tap 1)	All Inputs 40,000 [11.72] 60,000 [17.58] 80,000 [23.45] 100,000 [29.31]	10 x 9 Blower 1/2 HP [372 W] 3 Speed (X13 Motor)	Low Cool (Tap 2)	CFM [l/s]	1242 [586]	1213 [572]	1173 [554]	1132 [534]	1086 [513]	1044 [493]	1003 [473]	952 [449]
						RPM	912	934	972	1012	1055	1081	1109	1146
						Watts	249	252	262	271	275	282	283	288
3.5 [12.31]	High Cool (Tap 3)	Heat (Tap 1)	All Inputs 40,000 [11.72] 60,000 [17.58] 80,000 [23.45] 100,000 [29.31]	10 x 9 Blower 1/2 HP [372 W] 3 Speed (X13 Motor)	High Cool (Tap 3)	CFM [l/s]	1338 [631]	1309 [618]	1278 [603]	1234 [582]	1182 [558]	1135 [536]	1087 [513]	1007 [475]
						RPM	963	983	1016	1049	1096	1121	1142	1159
						Watts	304	307	316	321	328	332	330	315
3.5 [12.31]	High Cool (Tap 3)	Heat (Tap 1)	All Inputs 40,000 [11.72] 60,000 [17.58] 80,000 [23.45] 100,000 [29.31]	10 x 9 Blower 1/2 HP [372 W] 3 Speed (X13 Motor)	Heat Dedicated (Tap 1)	CFM [l/s]	1228 [580]	1187 [560]	1140 [538]	1105 [522]	1062 [501]	1008 [476]	959 [453]	911 [430]
						RPM	761	808	841	884	920	960	999	1038
						Watts	150	170	180	183	185	190	195	215
3.5 [12.31]	High Cool (Tap 3)	Heat (Tap 1)	All Inputs 40,000 [11.72] 60,000 [17.58] 80,000 [23.45] 100,000 [29.31]	10 x 9 Blower 1/2 HP [372 W] 3 Speed (X13 Motor)	Low Cool (Tap 2)	CFM [l/s]	1454 [686]	1433 [676]	1392 [657]	1354 [639]	1322 [624]	1283 [606]	1238 [584]	1192 [563]
						RPM	923	946	976	1015	1044	1085	1126	1146
						Watts	301	309	316	327	337	348	356	363
3.5 [12.31]	High Cool (Tap 3)	Heat (Tap 1)	All Inputs 40,000 [11.72] 60,000 [17.58] 80,000 [23.45] 100,000 [29.31]	10 x 9 Blower 1/2 HP [372 W] 3 Speed (X13 Motor)	High Cool (Tap 3)	CFM [l/s]	1544 [729]	1531 [723]	1473 [695]	1440 [680]	1398 [660]	1361 [642]	1317 [622]	1263 [596]
						RPM	958	973	1025	1046	1078	1109	1147	1163
						Watts	343	350	364	371	382	391	401	396

NOTES: (1) Do not operate 2 ton models below 700 CFM. (2) Do not operate 2 1/2 or 3 ton models below 875 CFM. (3) Cooling speed must be changed to low cool to achieve AHRI performance (all models).

[] Designates Metric Conversions



INDOOR AIRFLOW PERFORMANCE—208 VOLTS (continued)

Nominal Cooling Capacity Tons [kW]	Motor Speed from Factory		Heating Input BTU/HR [kW]	Blower Size/ Motor HP [W] & # of Speeds	Motor Speed	External Static Pressure—Inches W.C. [kPa] Side Discharge—Dry Coil								
	Cool	Heat				0.1 [.02]	0.2 [.05]	0.3 [.07]	0.4 [.10]	0.5 [.12]	0.6 [.15]	0.7 [.17]	0.8 [.20]	
4.0 [14.07]	High Cool (Tap 3)	Heat (Tap 1)	All Inputs 60,000 [17.58] 80,000 [23.45] 100,000 [29.31]	10 x 9 Blower 3/4 HP [555 W] 3 Speed (X13 Motor)	Heat Dedicated (Tap 1)	CFM [l/s]	1454 [686]	1433 [676]	1392 [657]	1354 [639]	1322 [624]	1283 [606]	1238 [584]	1192 [563]
						RPM	923	946	976	1015	1044	1085	1126	1146
						Watts	301	309	316	327	337	348	356	363
	Low Cool (Tap 2)	Heat (Tap 1)	All Inputs 60,000 [17.58] 80,000 [23.45] 100,000 [29.31]	10 x 9 Blower 3/4 HP [555 W] 3 Speed (X13 Motor)	Low Cool (Tap 2)	CFM [l/s]	1642 [775]	1621 [765]	1584 [748]	1542 [728]	1496 [706]	1451 [685]	1396 [659]	1299 [613]
						RPM	1006	1022	1064	1090	1114	1151	1160	1172
						Watts	405	412	422	435	442	449	440	414
High Cool (Tap 3)	Heat (Tap 1)	All Inputs 60,000 [17.58] 80,000 [23.45] 100,000 [29.31]	10 x 9 Blower 3/4 HP [555 W] 3 Speed (X13 Motor)	High Cool (Tap 3)	CFM [l/s]	1896 [895]	1863 [879]	1776 [838]	1694 [799]	1603 [757]	1528 [721]	1424 [672]	1316 [621]	
					RPM	1146	1147	1159	1171	1173	1180	1188	1195	
					Watts	624	614	583	554	522	497	467	432	
5.0 [17.59]	1st Stage Cool (Tap 2)	Med. (Tap 1)	100,000 [29.31]	12 x 9 1 HP [746 W] 4 Speed (X13 Motor)	Heat Dedicated (Tap 1)	CFM [l/s]	1418 [669]	1386 [654]	1352 [638]	1307 [617]	1270 [599]	1221 [576]	1180 [557]	1117 [527]
						RPM	774	794	829	860	892	922	955	1015
						Watts	267	273	287	295	308	316	328	343
	2nd Stage High Cool (Tap 4)	Med. (Tap 1)	100,000 [29.31]	12 x 9 1 HP [746 W] 4 Speed (X13 Motor)	1st Stage Cool (Tap 2)	CFM [l/s]	1310 [618]	1288 [608]	1238 [584]	1204 [568]	1149 [542]	1104 [521]	1035 [488]	971 [458]
						RPM	731	757	789	826	857	894	937	993
						Watts	218	229	237	250	258	270	280	294
	2nd Stage High Cool (Tap 4)	Med. (Tap 1)	100,000 [29.31]	12 x 9 1 HP [746 W] 4 Speed (X13 Motor)	2nd Stage Low Cool (Tap 3)	CFM [l/s]	1858 [877]	1821 [859]	1782 [841]	1752 [827]	1714 [809]	1678 [792]	1640 [774]	1607 [758]
						RPM	944	968	994	1019	1041	1072	1089	1111
						Watts	541	555	564	578	586	598	611	617
	2nd Stage High Cool (Tap 4)	Med. (Tap 1)	100,000 [29.31]	12 x 9 1 HP [746 W] 4 Speed (X13 Motor)	2nd Stage High Cool (Tap 4)	CFM [l/s]	2017 [952]	1985 [937]	1949 [920]	1909 [901]	1879 [887]	1843 [870]	1792 [846]	1737 [820]
						RPM	1018	1033	1070	1076	1112	1124	1147	1152
						Watts	690	701	711	723	735	741	742	728

NOTES: (1) Do not operate 2 ton models below 700 CFM. (2) Do not operate 2 1/2 or 3 ton models below 875 CFM. (3) Cooling speed must be changed to low cool to achieve AHRI performance (all models).

[] Designates Metric Conversions

DOWN DISCHARGE PRESSURE DROP (ADD TO EXTERNAL STATIC PRESSURE)							
CFM [l/s]	600 [283]	800 [378]	1000 [472]	1400 [661]	1600 [755]	1800 [849]	2000 [944]
Pressure Drop—Includes W.C. [kPa]	0	.02 [.005]	.05 [.012]	.1 [.025]	.12 [.030]	.15 [.037]	.17 [.042]

AIRFLOW PERFORMANCE—RRPL- SERIES



INDOOR AIRFLOW PERFORMANCE—230 VOLTS

Nominal Cooling Capacity Tons [kW]	Motor Speed from Factory		Heating Input BTU/HR [kW]	Blower Size/ Motor HP [W] & # of Speeds	Motor Speed	External Static Pressure—Inches W.C. [kPa] Side Discharge—Dry Coil									
	Cool	Heat				0.1 [0.02]	0.2 [0.05]	0.3 [0.07]	0.4 [1.10]	0.5 [1.12]	0.6 [1.15]	0.7 [1.17]	0.8 [1.20]		
2.0 [7.03]	High Cool (Tap 3)	Heat (Tap 1)	All Inputs 40,000 [11.72] 60,000 [17.58] 80,000 [23.45]	9 x 7 Blower 1/3 HP [249 W] 3 Speed (X13 Motor)	Heat Dedicated (Tap 1)	CFM [l/s]	829 [391]	808 [381]	789 [372]	756 [357]	737 [348]	697 [329]	668 [315]	615 [290]	
						RPM	890	915	148	1000	1046	1089	1121	1173	
						Watts	137	139	151	151	160	163	166	167	
2.5 [8.79]	High Cool (Tap 3)	Heat (Tap 1)	All Inputs 40,000 [11.72] 60,000 [17.58] 80,000 [23.45] 100,000 [29.31]	10 x 9 Blower 1/2 HP [372 W] 3 Speed (X13 Motor)	Low Cool (Tap 2)	CFM [l/s]	853 [403]	832 [393]	804 [379]	779 [368]	745 [352]	724 [342]	688 [325]	630 [297]	
						RPM	901	928	984	1013	1054	1099	1137	1185	
						Watts	146	149	159	161	165	173	176	173	
3.0 [10.55]	High Cool (Tap 3)	Heat (Tap 1)	All Inputs 40,000 [11.72] 60,000 [17.58] 80,000 [23.45] 100,000 [29.31]	10 x 9 Blower 1/2 HP [372 W] 3 Speed (X13 Motor)	High Cool (Tap 3)	CFM [l/s]	912 [430]	896 [423]	863 [407]	839 [396]	815 [385]	787 [371]	736 [347]	656 [310]	
						RPM	940	977	1017	1062	1088	1139	1165	1181	
						Watts	171	179	183	192	194	203	199	182	
3.5 [12.31]	High Cool (Tap 3)	Heat (Tap 1)	All Inputs 40,000 [11.72] 60,000 [17.58] 80,000 [23.45] 100,000 [29.31]	10 x 9 Blower 1/2 HP [372 W] 3 Speed (X13 Motor)	Heat Dedicated (Tap 1)	CFM [l/s]	1169 [552]	1140 [538]	1111 [524]	1068 [504]	1030 [486]	995 [470]	949 [448]	895 [422]	
						RPM	868	893	932	978	1010	1048	1086	1129	
						Watts	213	217	228	239	244	254	258	268	
3.5 [12.31]	High Cool (Tap 3)	Heat (Tap 1)	All Inputs 40,000 [11.72] 60,000 [17.58] 80,000 [23.45] 100,000 [29.31]	10 x 9 Blower 1/2 HP [372 W] 3 Speed (X13 Motor)	Low Cool (Tap 2)	CFM [l/s]	1039 [490]	1021 [482]	971 [458]	932 [440]	887 [419]	839 [396]	797 [376]	735 [347]	
						RPM	798	833	878	922	955	1011	1061	1093	
						Watts	159	168	175	185	189	200	210	213	
3.5 [12.31]	High Cool (Tap 3)	Heat (Tap 1)	All Inputs 40,000 [11.72] 60,000 [17.58] 80,000 [23.45] 100,000 [29.31]	10 x 9 Blower 1/2 HP [372 W] 3 Speed (X13 Motor)	High Cool (Tap 3)	CFM [l/s]	1256 [593]	1231 [581]	1201 [567]	1161 [548]	1115 [526]	1076 [508]	1043 [492]	999 [471]	
						RPM	921	942	976	1018	1053	1093	1131	1149	
						Watts	259	263	272	284	290	299	309	307	
3.5 [12.31]	High Cool (Tap 3)	Heat (Tap 1)	All Inputs 40,000 [11.72] 60,000 [17.58] 80,000 [23.45] 100,000 [29.31]	10 x 9 Blower 1/2 HP [372 W] 3 Speed (X13 Motor)	Heat Dedicated (Tap 1)	CFM [l/s]	1169 [552]	1140 [538]	1111 [524]	1068 [504]	1030 [486]	995 [470]	949 [448]	895 [422]	
						RPM	868	893	932	978	1010	1048	1086	1129	
						Watts	213	217	228	239	244	254	258	268	
3.5 [12.31]	High Cool (Tap 3)	Heat (Tap 1)	All Inputs 40,000 [11.72] 60,000 [17.58] 80,000 [23.45] 100,000 [29.31]	10 x 9 Blower 1/2 HP [372 W] 3 Speed (X13 Motor)	Low Cool (Tap 2)	CFM [l/s]	1256 [593]	1231 [581]	1201 [567]	1161 [548]	1115 [526]	1076 [508]	1043 [492]	999 [471]	
						RPM	921	942	976	1018	1053	1093	1131	1149	
						Watts	259	263	272	284	290	299	309	307	
3.5 [12.31]	High Cool (Tap 3)	Heat (Tap 1)	All Inputs 40,000 [11.72] 60,000 [17.58] 80,000 [23.45] 100,000 [29.31]	10 x 9 Blower 1/2 HP [372 W] 3 Speed (X13 Motor)	High Cool (Tap 3)	CFM [l/s]	1357 [640]	1330 [628]	1292 [610]	1262 [596]	1225 [578]	1178 [556]	1110 [524]	1033 [488]	
						RPM	974	1003	1036	1071	1103	1134	1153	1169	
						Watts	318	323	333	343	347	356	345	328	
3.5 [12.31]	High Cool (Tap 3)	Heat (Tap 1)	All Inputs 40,000 [11.72] 60,000 [17.58] 80,000 [23.45] 100,000 [29.31]	10 x 9 Blower 1/2 HP [372 W] 3 Speed (X13 Motor)	Heat Dedicated (Tap 1)	CFM [l/s]	1241 [586]	1203 [568]	1155 [545]	1119 [528]	1082 [511]	1032 [487]	994 [469]	950 [448]	
						RPM	771	815	848	886	932	965	1004	1044	
						Watts	155	162	170	182	193	200	210	220	
3.5 [12.31]	High Cool (Tap 3)	Heat (Tap 1)	All Inputs 40,000 [11.72] 60,000 [17.58] 80,000 [23.45] 100,000 [29.31]	10 x 9 Blower 1/2 HP [372 W] 3 Speed (X13 Motor)	Low Cool (Tap 2)	CFM [l/s]	1459 [689]	1438 [679]	1409 [665]	1371 [647]	1337 [631]	1296 [612]	1258 [594]	1223 [577]	
						RPM	931	958	993	1031	1058	1097	1133	1158	
						Watts	308	319	331	339	349	362	373	381	
3.5 [12.31]	High Cool (Tap 3)	Heat (Tap 1)	All Inputs 40,000 [11.72] 60,000 [17.58] 80,000 [23.45] 100,000 [29.31]	10 x 9 Blower 1/2 HP [372 W] 3 Speed (X13 Motor)	High Cool (Tap 3)	CFM [l/s]	1562 [737]	1538 [726]	1500 [708]	1456 [687]	1434 [677]	1383 [653]	1339 [632]	1270 [599]	
						RPM	960	991	1017	1055	1089	1121	1154	1169	
						Watts	353	364	375	388	398	408	418	405	

NOTES: (1) Do not operate 2 ton models below 700 CFM. (2) Do not operate 2 1/2 or 3 ton models below 875 CFM. (3) Cooling speed must be changed to low cool to achieve AHRI performance (all models).

[] Designates Metric Conversions



INDOOR AIRFLOW PERFORMANCE—230 VOLTS (continued)

Nominal Cooling Capacity Tons [kW]	Motor Speed from Factory		Heating Input BTU/HR [kW]	Blower Size/ Motor HP [W] & # of Speeds	Motor Speed	External Static Pressure—Inches W.C. [kPa] Side Discharge—Dry Coil								
	Cool	Heat				0.1 [.02]	0.2 [.05]	0.3 [.07]	0.4 [.10]	0.5 [.12]	0.6 [.15]	0.7 [.17]	0.8 [.20]	
4.0 [14.07]	High Cool (Tap 3)	Heat (Tap 1)	All Inputs 60,000 [17.58] 80,000 [23.45] 100,000 [29.31]	10 x 9 Blower 3/4 HP [555 W] 3 Speed (X13 Motor)	Heat Dedicated (Tap 1)	CFM [l/s]	1459 [689]	1438 [679]	1409 [665]	1371 [647]	1337 [631]	1296 [612]	1258 [594]	1223 [577]
						RPM	931	958	993	1031	1058	1097	1133	1158
						Watts	308	319	331	339	349	362	373	381
	Low Cool (Tap 2)	Heat (Tap 1)	All Inputs 60,000 [17.58] 80,000 [23.45] 100,000 [29.31]	10 x 9 Blower 3/4 HP [555 W] 3 Speed (X13 Motor)	Low Cool (Tap 2)	CFM [l/s]	1662 [784]	1648 [778]	1607 [758]	1579 [745]	1538 [726]	1477 [697]	1392 [657]	1305 [616]
						RPM	1016	1037	1072	1098	1129	1156	1169	1179
						Watts	421	429	443	453	465	465	446	420
High Cool (Tap 3)	Heat (Tap 1)	All Inputs 60,000 [17.58] 80,000 [23.45] 100,000 [29.31]	10 x 9 Blower 3/4 HP [555 W] 3 Speed (X13 Motor)	High Cool (Tap 3)	CFM [l/s]	1910 [901]	1873 [884]	1798 [849]	1715 [809]	1621 [765]	1536 [725]	1422 [671]	1323 [624]	
					RPM	1149	1160	1163	1169	1175	1187	1184	1205	
					Watts	638	625	601	571	536	506	469	440	
5.0 [17.59]	1st Stage Cool (Tap 2)	Med. (Tap 1)	100,000 [29.31]	12 x 9 Blower 1 HP [746 W] 4 Speed (X13 Motor)	Heat Dedicated (Tap 1)	CFM [l/s]	1423 [672]	1390 [656]	1357 [640]	1311 [619]	1277 [603]	1233 [582]	1192 [563]	1137 [537]
						RPM	776	796	830	861	895	927	958	999
						Watts	272	278	292	300	315	326	337	352
						CFM [l/s]	1319 [622]	1289 [608]	1242 [586]	1201 [567]	1148 [542]	1111 [524]	1047 [494]	985 [465]
						RPM	728	760	790	832	859	894	939	992
						Watts	222	234	241	256	263	276	287	304
	2nd Stage High Cool (Tap 4)	Med. (Tap 1)	100,000 [29.31]	12 x 9 Blower 1 HP [746 W] 4 Speed (X13 Motor)	2nd Stage Low Cool (Tap 3)	CFM [l/s]	1872 [883]	1847 [872]	1808 [853]	1772 [836]	1743 [823]	1703 [804]	1670 [788]	1639 [774]
						RPM	956	973	1010	1023	1057	1085	1110	1146
						Watts	562	572	584	598	613	622	636	646
						CFM [l/s]	2046 [966]	2010 [949]	1980 [934]	1942 [917]	1904 [899]	1867 [881]	1822 [860]	1758 [830]
						RPM	1035	1046	1079	1086	1114	1141	1171	1163
						Watts	721	731	743	754	770	777	770	751

NOTES: (1) Do not operate 2 ton models below 700 CFM. (2) Do not operate 2 1/2 or 3 ton models below 875 CFM. (3) Cooling speed must be changed to low cool to achieve AHRI performance (all models).

[] Designates Metric Conversions

DOWN DISCHARGE PRESSURE DROP (ADD TO EXTERNAL STATIC PRESSURE)								
CFM [l/s]	600 [283]	800 [378]	1000 [472]	1200 [566]	1400 [661]	1600 [755]	1800 [849]	2000 [944]
Pressure Drop—Includes W.C. [kPa]	0	.02 [.005]	.05 [.012]	.07 [.017]	.1 [.025]	.12 [.030]	.15 [.037]	.17 [.042]



INDOOR AIRFLOW PERFORMANCE—208 & 230 VOLTS (continued)

DOWN DISCHARGE PRESSURE DROP (ADD TO EXTERNAL STATIC PRESSURE)										
CFM [L/s]	600 [283]	800 [378]	1000 [472]	1200 [566]	1400 [661]	1600 [755]	1800 [849]	2000 [944]		
Pressure Drop—Includes W.C. [kPa]	0	.02 [.005]	.05 [.012]	.07 [.017]	.1 [.025]	.12 [.030]	.15 [.037]	.17 [.042]		

[] Designates Metric Conversions



ELECTRICAL DATA – RRNL- SERIES													
		-B024JK04	-B024JK06	-B024JK08	-B030JK04	-B030JK06	-B030JK08	-B030JK10	-B036CK04	-B036CK06	-B036CK08	-B036CK10	-B036DK06
Unit Information	Unit Operating Voltage Range	187-253	187-253	187-253	187-253	187-253	187-253	187-253	187-253	187-253	187-253	187-253	414-506
	Minimum Circuit Ampacity	19/19	19/19	19/19	22/22	22/22	22/22	22/22	17/17	17/17	17/17	17/17	9
	Minimum Overcurrent Protection Device Size	20/20	20/20	20/20	25/25	25/25	25/25	25/25	20/20	20/20	20/20	20/20	15
	Maximum Overcurrent Protection Device Size	30/30	30/30	30/30	35/35	35/35	35/35	35/35	25/25	25/25	25/25	25/25	20
Compressor Motor	No.	1	1	1	1	1	1	1	1	1	1	1	1
	Volts	208/230	208/230	208/230	208/230	208/230	208/230	208/230	208/230	208/230	208/230	208/230	460
	Phase	1	1	1	1	1	1	1	3	3	3	3	3
	HP	2 1/6	2 1/6	2 1/6	2 2/3	2 2/3	2 2/3	2 2/3	3 1/3	3 1/3	3 1/3	3 1/3	3 1/3
	RPM	3450	3450	3450	3450	3450	3450	3450	3450	3450	3450	3450	3450
	Amps (RLA)	12.8/12.8	12.8/12.8	12.8/12.8	14.1/14.1	14.1/14.1	14.1/14.1	14.1/14.1	10.4/10.4	10.4/10.4	10.4/10.4	10.4/10.4	5.8
	Amps (LRA)	58.3/58.3	58.3/58.3	58.3/58.3	73/73	73/73	73/73	73/73	88/88	88/88	88/88	88/88	38
Condenser Motor	No.	1	1	1	1	1	1	1	1	1	1	1	1
	Volts	208/230	208/230	208/230	208/230	208/230	208/230	208/230	208/230	208/230	208/230	208/230	460
	Phase	1	1	1	1	1	1	1	1	1	1	1	1
	HP	1/3	1/3	1/3	1/3	1/3	1/3	1/3	1/3	1/3	1/3	1/3	1/3
	Amps (FLA)	1.3	1.3	1.3	1.3	1.3	1.3	1.3	1.3	1.3	1.3	1.3	0.6
	Amps (LRA)	2.3	2.3	2.3	2.3	2.3	2.3	2.3	2.3	2.3	2.3	2.3	1.1
Evaporator Fan	No.	1	1	1	1	1	1	1	1	1	1	1	1
	Volts	208/230	208/230	208/230	208/230	208/230	208/230	208/230	208/230	208/230	208/230	208/230	460
	Phase	1	1	1	1	1	1	1	1	1	1	1	1
	HP	1/4	1/4	1/4	1/2	1/2	1/2	1/2	1/2	1/2	1/2	1/2	1/2
	Amps (FLA)	1.3	1.3	1.3	2.4	2.4	2.4	2.4	2.4	2.4	2.4	2.4	1.2
	Amps (LRA)	2.3	2.3	2.3	5.1	5.1	5.1	5.1	5.1	5.1	5.1	5.1	2.2

1. Horsepower Per Compressor.
2. Amp Draw Per Motor. Multiply Value By Number of Motors to Determine Total Amps.



ELECTRICAL DATA – RRNL- SERIES														
		-B036DK08	-B036DK10	-B036JK04	-B036JK06	-B036JK08	-B036JK10	-B042CK04	-B042CK06	-B042CK08	-B042CK10	-B042JK04	-B042JK06	
Unit Information	Unit Operating Voltage Range	414-506	414-506	187-253	187-253	187-253	187-253	187-253	187-253	187-253	187-253	187-253	187-253	
	Minimum Circuit Ampacity	9	9	25/25	25/25	25/25	25/25	22/22	22/22	22/22	22/22	27/27	27/27	
	Minimum Overcurrent Protection Device Size	15	15	25/25	25/25	25/25	25/25	25/25	25/25	25/25	25/25	30/30	30/30	
	Maximum Overcurrent Protection Device Size	20	20	40/40	40/40	40/40	40/40	30/30	30/30	30/30	30/30	40/40	40/40	
Compressor Motor	No.	1	1	1	1	1	1	1	1	1	1	1	1	
	Volts	460	460	208/230	208/230	208/230	208/230	208/230	208/230	208/230	208/230	208/230	208/230	
	Phase	3	3	1	1	1	1	3	3	3	3	1	1	
	HP	3 1/3	3 1/3	3 1/3	3 1/3	3 1/3	3 1/3	3 1/2	3 1/2	3 1/2	3 1/2	3 1/2	3 1/2	
	RPM	3450	3450	3450	3450	3450	3450	3450	3450	3450	3450	3450	3450	
	Amps (RLA)	5.8	5.8	16.7/16.7	16.7/16.7	16.7/16.7	16.7/16.7	13.5/13.5	13.5/13.5	13.5/13.5	13.5/13.5	13.5/13.5	17.9/17.9	17.9/17.9
	Amps (LRA)	38	38	79/79	79/79	79/79	79/79	88/88	88/88	88/88	88/88	88/88	112/112	112/112
Condenser Motor	No.	1	1	1	1	1	1	1	1	1	1	1	1	
	Volts	460	460	208/230	208/230	208/230	208/230	208/230	208/230	208/230	208/230	208/230	208/230	
	Phase	1	1	1	1	1	1	1	1	1	1	1	1	
	HP	1/3	1/3	1/3	1/3	1/3	1/3	1/3	1/3	1/3	1/3	1/3	1/3	
	Amps (FLA)	0.6	0.6	1.3	1.3	1.3	1.3	2	2	2	2	2	2	
	Amps (LRA)	1.1	1.1	2.3	2.3	2.3	2.3	3.9	3.9	3.9	3.9	3.9	3.9	
Evaporator Fan	No.	1	1	1	1	1	1	1	1	1	1	1	1	
	Volts	460	460	208/230	208/230	208/230	208/230	208/230	208/230	208/230	208/230	208/230	208/230	
	Phase	1	1	1	1	1	1	1	1	1	1	1	1	
	HP	1/2	1/2	1/2	1/2	1/2	1/2	1/2	1/2	1/2	1/2	1/2	1/2	
	Amps (FLA)	1.2	1.2	2.4	2.4	2.4	2.4	2.4	2.4	2.4	2.4	2.4	2.4	
	Amps (LRA)	2.2	2.2	5.1	5.1	5.1	5.1	5.1	5.1	5.1	5.1	5.1	5.1	

1. Horsepower Per Compressor.
 2. Amp Draw Per Motor. Multiply Value By Number of Motors to Determine Total Amps.



ELECTRICAL DATA – RRNL- SERIES												
		-B042JK08	-B042JK10	-B048CK06	-B048CK08	-B048CK10	-B048DK10	-B048JK06	-B048JK08	-B048JK10	-C060CK10	-C060JK10
Unit Information	Unit Operating Voltage Range	187-253	187-253	187-253	187-253	187-253	414-506	187-253	187-253	187-253	197-253	197-253
	Minimum Circuit Ampacity	27/27	27/27	24/24	24/24	24/24	12	34/34	34/34	34/34	32/32	43/43
	Minimum Overcurrent Protection Device Size	30/30	30/30	25/25	25/25	25/25	15	35/35	35/35	35/35	35/35	45/45
	Maximum Overcurrent Protection Device Size	40/40	40/40	35/35	35/35	35/35	20	50/50	50/50	50/50	45/45	60/60
Compressor Motor	No.	1	1	1	1	1	1	1	1	1	1	1
	Volts	208/230	208/230	208/230	208/230	208/230	460	208/230	208/230	208/230	208/230	208/230
	Phase	1	1	3	3	3	3	1	1	1	3	1
	HP	3 1/2	3 1/2	4	4	4	4	4	4	4	5	5
	RPM	3450	3450	3450	3450	3450	3450	3450	3450	3450	3450	3450
	Amps (RLA)	17.9/17.9	17.9/17.9	13.7/13.7	13.7/13.7	13.7/13.7	6.2	21.8/21.8	21.8/21.8	21.8/21.8	17.9/17.9	26.4/26.4
	Amps (LRA)	112/112	112/112	83.1/83.1	83.1/83.1	83.1/83.1	41	117/117	117/117	117/117	110/110	134/134
Condenser Motor	No.	1	1	1	1	1	1	1	1	1	1	1
	Volts	208/230	208/230	208/230	208/230	208/230	460	208/230	208/230	208/230	208/230	208/230
	Phase	1	1	1	1	1	1	1	1	1	1	1
	HP	1/3	1/3	1/3	1/3	1/3	1/3	1/3	1/3	1/3	1/3	1/3
	Amps (FLA)	2	2	2	2	2	1	2	2	2	2	2
	Amps (LRA)	3.9	3.9	3.9	3.9	3.9	2.2	3.9	3.9	3.9	3.9	3.9
Evaporator Fan	No.	1	1	1	1	1	1	1	1	1	1	1
	Volts	208/230	208/230	208/230	208/230	208/230	460	208/230	208/230	208/230	208/230	208/230
	Phase	1	1	1	1	1	1	1	1	1	1	1
	HP	1/2	1/2	3/4	3/4	3/4	3/4	3/4	3/4	3/4	1	1
	Amps (FLA)	2.4	2.4	4.4	4.4	4.4	2.3	4.4	4.4	4.4	7.6	7.6
	Amps (LRA)	5.1	5.1	9.5	9.5	9.5	5	9.5	9.5	9.5	0	0

1. Horsepower Per Compressor.

2. Amp Draw Per Motor. Multiply Value By Number of Motors to Determine Total Amps.



ELECTRICAL DATA – RRPL- SERIES														
		-B024JK04	-B024JK06	-B024JK08	-B030JK04	-B030JK06	-B030JK08	-B030JK10	-B036CK04	-B036CK06	-B036CK08	-B036CK10	-B036JK04	
Unit Information	Unit Operating Voltage Range	187-253	187-253	187-253	187-253	187-253	187-253	187-253	187-253	187-253	187-253	187-253	187-253	
	Minimum Circuit Ampacity	21/21	21/21	21/21	24/24	24/24	24/24	24/24	19/19	19/19	19/19	19/19	27/27	
	Minimum Overcurrent Protection Device Size	25/25	25/25	25/25	25/25	25/25	25/25	25/25	20/20	20/20	20/20	20/20	30/30	
	Maximum Overcurrent Protection Device Size	30/30	30/30	30/30	35/35	35/35	35/35	35/35	25/25	25/25	25/25	25/25	40/40	
Compressor Motor	No.	1	1	1	1	1	1	1	1	1	1	1	1	
	Volts	208/230	208/230	208/230	208/230	208/230	208/230	208/230	208/230	208/230	208/230	208/230	208/230	
	Phase	1	1	1	1	1	1	1	3	3	3	3	1	
	HP	2 1/6	2 1/6	2 1/6	2 2/3	2 2/3	2 2/3	2 2/3	3 1/3	3 1/3	3 1/3	3 1/3	3 1/3	
	RPM	3450	3450	3450	3450	3450	3450	3450	3450	3450	3450	3450	3450	
	Amps (RLA)	12.8/12.8	12.8/12.8	12.8/12.8	14.1/14.1	14.1/14.1	14.1/14.1	14.1/14.1	10.4/10.4	10.4/10.4	10.4/10.4	10.4/10.4	10.4/10.4	16.7/16.7
	Amps (LRA)	58.3/58.3	58.3/58.3	58.3/58.3	73/73	73/73	73/73	73/73	88/88	88/88	88/88	88/88	88/88	79/79
Condenser Motor	No.	1	1	1	1	1	1	1	1	1	1	1	1	
	Volts	208/230	208/230	208/230	208/230	208/230	208/230	208/230	208/230	208/230	208/230	208/230	208/230	
	Phase	1	1	1	1	1	1	1	1	1	1	1	1	
	HP	1/3	1/3	1/3	1/3	1/3	1/3	1/3	1/3	1/3	1/3	1/3	1/3	
	Amps (FLA)	1.3	1.3	1.3	1.3	1.3	1.3	1.3	1.3	1.3	1.3	1.3	1.3	
	Amps (LRA)	2.3	2.3	2.3	2.3	2.3	2.3	2.3	2.3	2.3	2.3	2.3	2.3	
Evaporator Fan	No.	1	1	1	1	1	1	1	1	1	1	1	1	
	Volts	208/230	208/230	208/230	208/230	208/230	208/230	208/230	208/230	208/230	208/230	208/230	208/230	
	Phase	1	1	1	1	1	1	1	1	1	1	1	1	
	HP	1/3	1/3	1/3	1/2	1/2	1/2	1/2	1/2	1/2	1/2	1/2	1/2	
	Amps (FLA)	2.8	2.8	2.8	4.1	4.1	4.1	4.1	4.1	4.1	4.1	4.1	4.1	
	Amps (LRA)	0	0	0	0	0	0	0	0	0	0	0	0	

1. Horsepower Per Compressor.
2. Amp Draw Per Motor. Multiply Value By Number of Motors to Determine Total Amps.



ELECTRICAL DATA – RRPL- SERIES													
		-B036JK06	-B036JK08	-B036JK10	-B042CK04	-B042CK06	-B042CK08	-B042CK10	-B042JK04	-B042JK06	-B042JK08	-B042JK10	-B048CK06
Unit Information	Unit Operating Voltage Range	187-253	187-253	187-253	187-253	187-253	187-253	187-253	187-253	187-253	187-253	187-253	187-253
	Minimum Circuit Ampacity	27/27	27/27	27/27	24/24	24/24	24/24	24/24	29/29	29/29	29/29	29/29	26/26
	Minimum Overcurrent Protection Device Size	30/30	30/30	30/30	25/25	25/25	25/25	25/25	30/30	30/30	30/30	30/30	30/30
	Maximum Overcurrent Protection Device Size	40/40	40/40	40/40	35/35	35/35	35/35	35/35	45/45	45/45	45/45	45/45	35/35
Compressor Motor	No.	1	1	1	1	1	1	1	1	1	1	1	1
	Volts	208/230	208/230	208/230	208/230	208/230	208/230	208/230	208/230	208/230	208/230	208/230	208/230
	Phase	1	1	1	3	3	3	3	1	1	1	1	3
	HP	3 1/3	3 1/3	3 1/3	3 1/2	3 1/2	3 1/2	3 1/2	3 1/2	3 1/2	3 1/2	3 1/2	4
	RPM	3450	3450	3450	3450	3450	3450	3450	3450	3450	3450	3450	3450
	Amps (RLA)	16.7/16.7	16.7/16.7	16.7/16.7	13.5/13.5	13.5/13.5	13.5/13.5	13.5/13.5	17.9/17.9	17.9/17.9	17.9/17.9	17.9/17.9	13.7/13.7
	Amps (LRA)	79/79	79/79	79/79	88/88	88/88	88/88	88/88	112/112	112/112	112/112	112/112	83.1/83.1
Condenser Motor	No.	1	1	1	1	1	1	1	1	1	1	1	1
	Volts	208/230	208/230	208/230	208/230	208/230	208/230	208/230	208/230	208/230	208/230	208/230	208/230
	Phase	1	1	1	1	1	1	1	1	1	1	1	1
	HP	1/3	1/3	1/3	1/3	1/3	1/3	1/3	1/3	1/3	1/3	1/3	1/3
	Amps (FLA)	1.3	1.3	1.3	2	2	2	2	2	2	2	2	2
	Amps (LRA)	2.3	2.3	2.3	3.9	3.9	3.9	3.9	3.9	3.9	3.9	3.9	3.9
Evaporator Fan	No.	1	1	1	1	1	1	1	1	1	1	1	1
	Volts	208/230	208/230	208/230	208/230	208/230	208/230	208/230	208/230	208/230	208/230	208/230	208/230
	Phase	1	1	1	1	1	1	1	1	1	1	1	1
	HP	1/2	1/2	1/2	1/2	1/2	1/2	1/2	1/2	1/2	1/2	1/2	3/4
	Amps (FLA)	4.1	4.1	4.1	4.1	4.1	4.1	4.1	4.1	4.1	4.1	4.1	6
Amps (LRA)	0	0	0	0	0	0	0	0	0	0	0	0	

1. Horsepower Per Compressor.
2. Amp Draw Per Motor. Multiply Value By Number of Motors to Determine Total Amps.



ELECTRICAL DATA – RRPL- SERIES								
		-B048CK08	-B048CK10	-B048JK06	-B048JK08	-B048JK10	-B060CK10	-B060JK10
Unit Information	Unit Operating Voltage Range	187-253	187-253	187-253	187-253	187-253	197-253	197-253
	Minimum Circuit Ampacity	26/26	26/26	36/36	36/36	36/36	32/32	42/42
	Minimum Overcurrent Protection Device Size	30/30	30/30	40/40	40/40	40/40	35/35	45/45
	Maximum Overcurrent Protection Device Size	35/35	35/35	50/50	50/50	50/50	45/45	60/60
Compressor Motor	No.	1	1	1	1	1	1	1
	Volts	208/230	208/230	208/230	208/230	208/230	208/230	208/230
	Phase	3	3	1	1	1	3	1
	HP	4	4	4	4	4	5	5
	RPM	3450	3450	3450	3450	3450	3450	3450
	Amps (RLA)	13.7/13.7	13.7/13.7	21.8/21.8	21.8/21.8	21.8/21.8	17.6/17.6	25.6/25.6
	Amps (LRA)	83.1/83.1	83.1/83.1	117/117	117/117	117/117	123/123	118/118
Condenser Motor	No.	1	1	1	1	1	1	1
	Volts	208/230	208/230	208/230	208/230	208/230	208/230	208/230
	Phase	1	1	1	1	1	1	1
	HP	1/3	1/3	1/3	1/3	1/3	1/3	1/3
	Amps (FLA)	2	2	2	2	2	2	2
	Amps (LRA)	3.9	3.9	3.9	3.9	3.9	3.9	3.9
Evaporator Fan	No.	1	1	1	1	1	1	1
	Volts	208/230	208/230	208/230	208/230	208/230	208/230	208/230
	Phase	1	1	1	1	1	1	1
	HP	3/4	3/4	3/4	3/4	3/4	1	1
	Amps (FLA)	6	6	6	6	6	7.6	7.6
	Amps (LRA)	0	0	0	0	0	0	0

1. Horsepower Per Compressor.

2. Amp Draw Per Motor. Multiply Value By Number of Motors to Determine Total Amps.



ELECTRICAL DATA – RRRL- SERIES								
		C024JK	C036CK	C036JK	C048CK	C048JK	C060CK	C060JK
Unit Information	Unit Operating Voltage Range	197-253	197-253	197-253	197-253	197-253	197-253	197-253
	Volts	208/230	208/230	208/230	208/230	208/230	208/230	208/230
	Minimum Circuit Ampacity	15/15	17/17	24/24	22/22	31/31	28/28	38/38
	Minimum Overcurrent Protection Device Size	20/20	20/20	30/30	25/25	40/40	35/35	45/45
	Maximum Overcurrent Protection Device Size	20/20	25/25	40/40	30/30	50/50	45/45	60/60
Compressor Motor	No.	1	1	1	1	1	1	1
	Volts	208/230	208/230	208/230	208/230	208/230	208/230	208/230
	Phase	1	3	1	3	1	3	1
	RPM	3450	3450	3450	3450	3450	3450	3450
	HP, Compressor 1	2 5/6	4	4	5 1/4	5 1/4	7	6 2/3
	Amps (RLA), Comp. 1	10.3/10.3	11.2/11.2	16.7/16.7	13.5/13.5	21.2/21.2	17.6/17.6	25.6/25.6
	Amps (LRA), Comp. 1	52/52	58/58	82/82	88/88	96/96	123/123	118/118
Condenser Motor	No.	1	1	1	1	1	1	1
	Volts	208/230	208/230	208/230	208/230	208/230	208/230	208/230
	Phase	1	1	1	1	1	1	1
	HP	1/6	1/6	1/6	1/3	1/3	1/3	1/3
	Amps (FLA, each)	0.6/0.6	0.6/0.6	0.6/0.6	1.5/1.5	1.5/1.5	2/2	2/2
	Amps (LRA, each)	1.5/1.5	1.5/1.5	1.5/1.5	3/3	3/3	3.9/3.9	3.9/3.9
Evaporator Fan	No.	1	1	1	1	1	1	1
	Volts	208/230	208/230	208/230	208/230	208/230	208/230	208/230
	Phase	1	1	1	1	1	1	1
	HP	1/3	1/2	1/2	3/4	3/4	1	1
	Amps (FLA, each)	1/1	2/2	2/2	3/3	3/3	4/4	4/4
	Amps (LRA, each)	0/0	0/0	0/0	0/0	0/0	0/0	0/0

1. Horsepower Per Compressor.

2. Amp Draw Per Motor. Multiply Value By Number of Motors to Determine Total Amps.



UNIT DIMENSIONS GAS HEAT/ELECTRIC COOLING PACKAGE

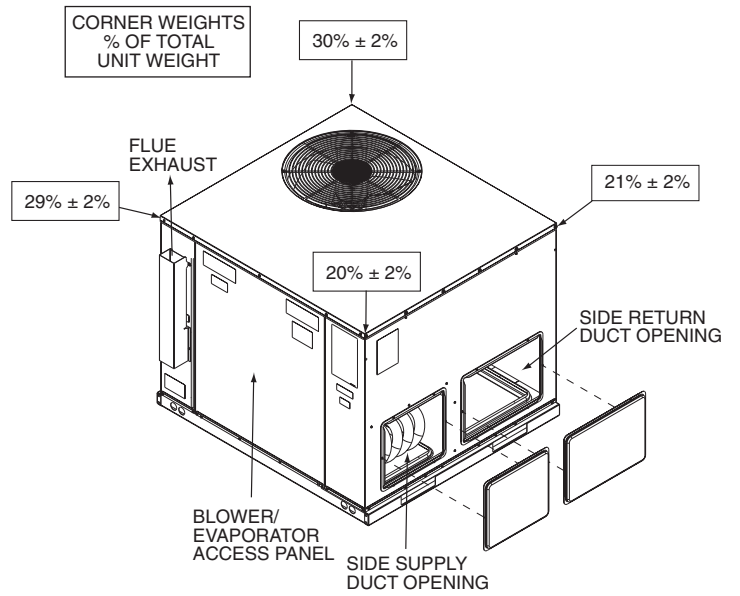
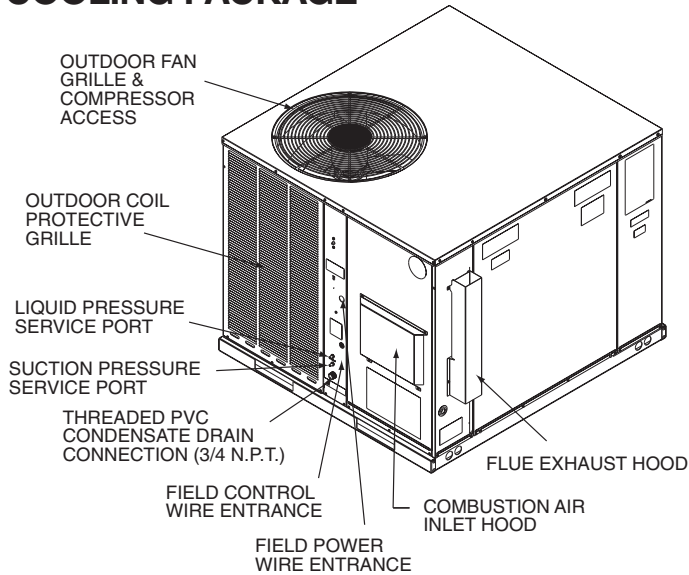

TOP VIEW

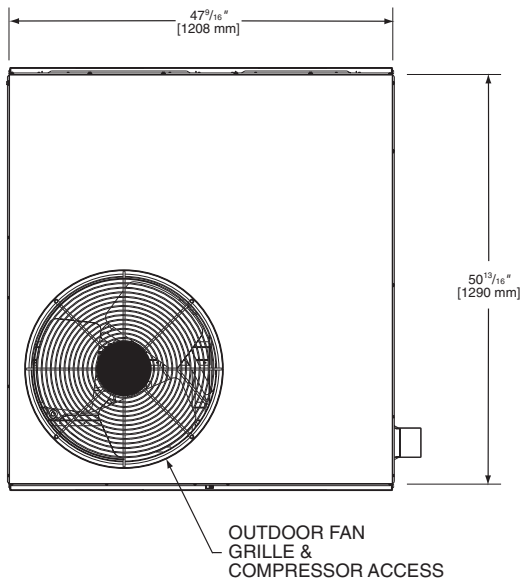

BOTTOM VIEW

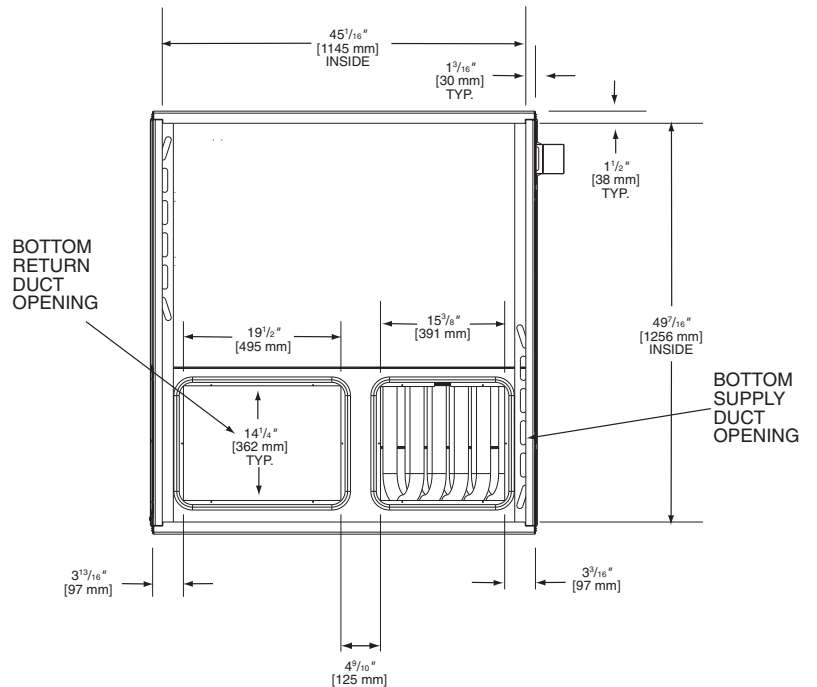

[] Designates Metric Conversions

SIDE VIEW

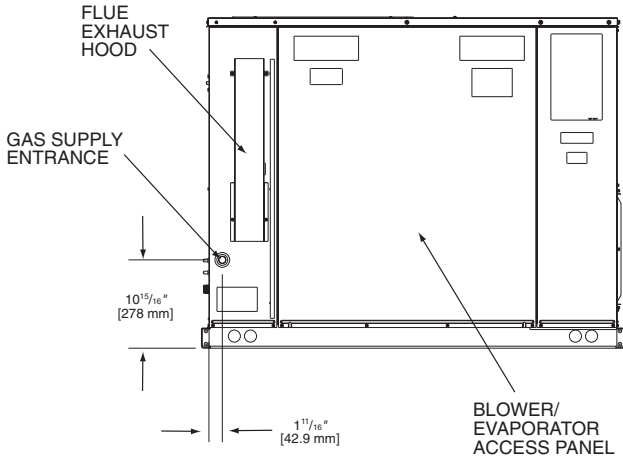

SIDE VIEW

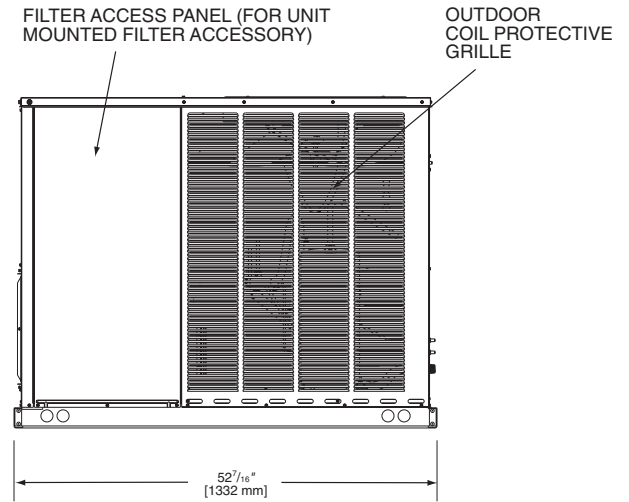

FRONT VIEW

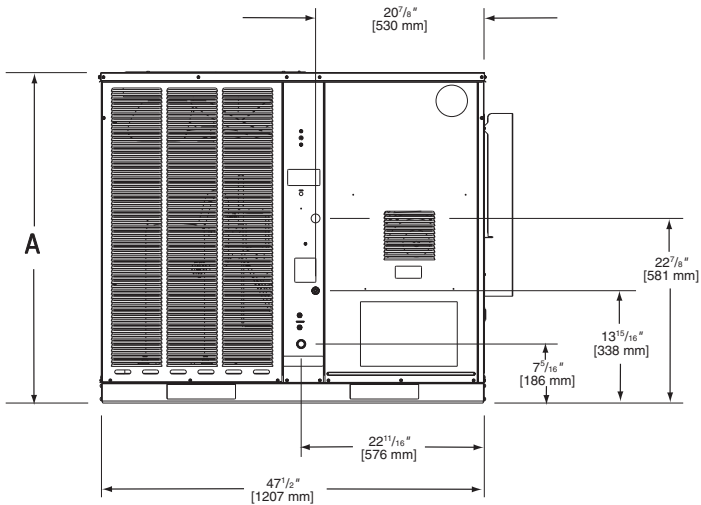

BACK VIEW

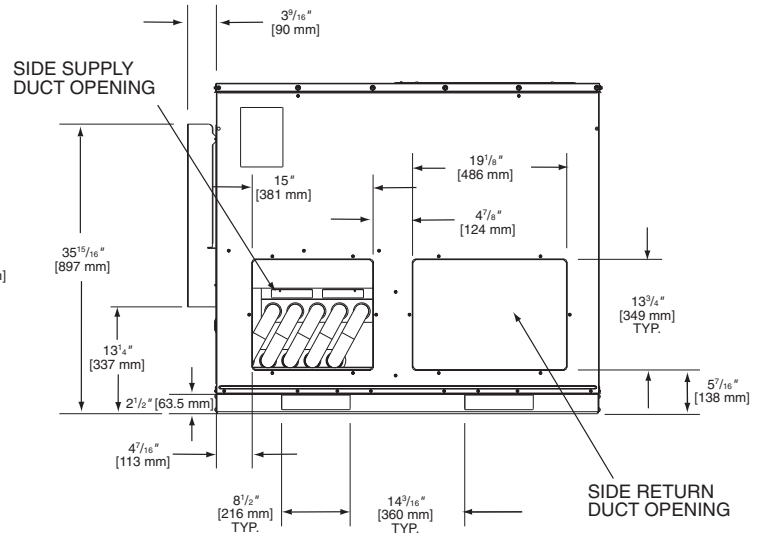

SHOWN WITH DUCT COVERS REMOVED.

Models: RRNL/RRPL	Model: RRRL	"A" Height
B024, B030, B036	B024	$35^{15}/16"$
B042, B048, B060/C060	B036, B048, B060	41"

[] Designates Metric Conversions

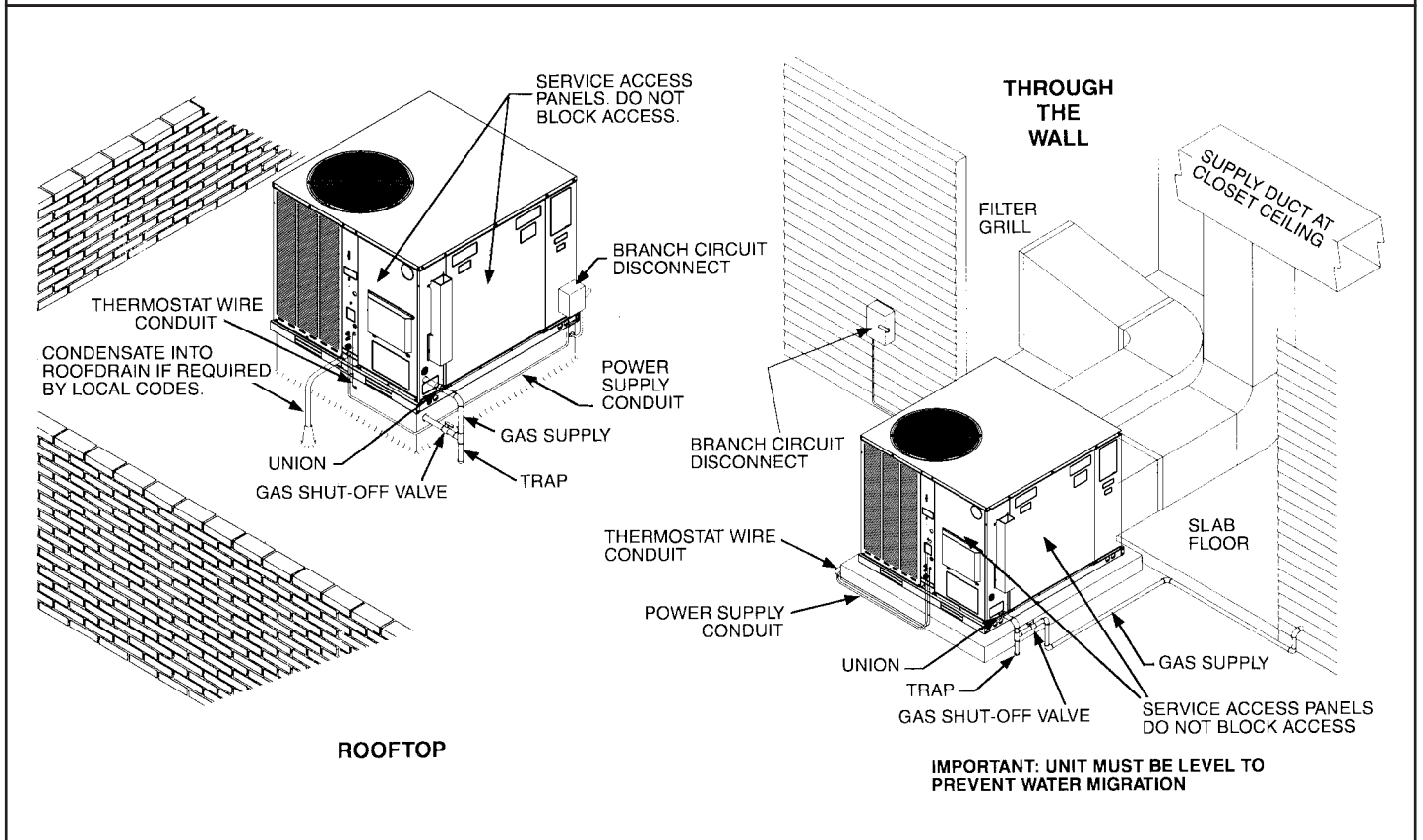
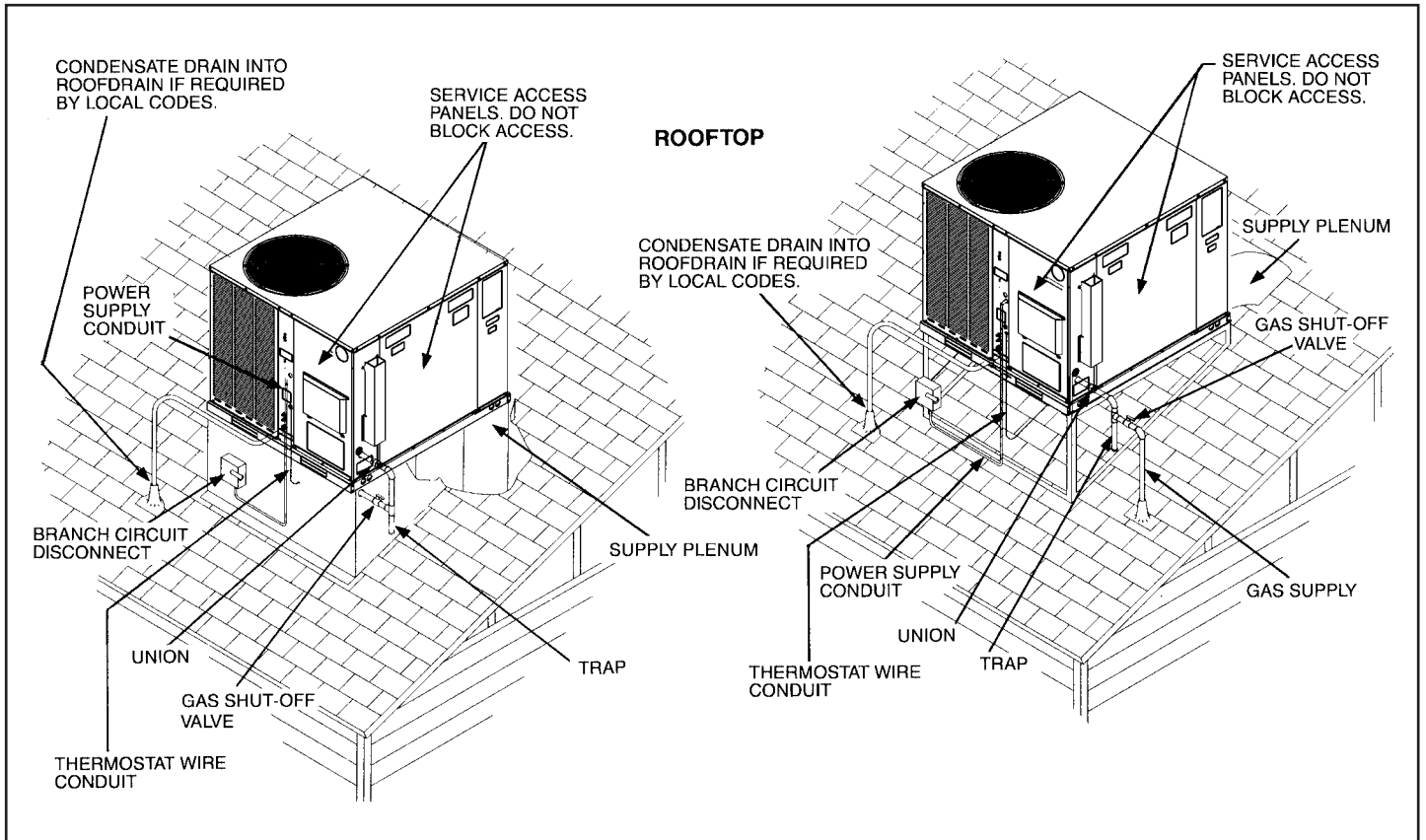

[] Designates Metric Conversions

ACCESSORY EQUIPMENT

Accessory Description	Model Application	Accessory Model No.
Thermostats	RRNL-/RRPL-/RRRL-	See Thermostat Specification Sheet (T11-001)
Roofcurbs	RRNL-/RRPL-/RRRL-	RXSG-AAA08 (8" [203 mm] Height) RXSG-AAA14 (14" [356 mm] Height) RXSG-AAA24 (24" [610 mm] Height)
Supply & Return Diffusers	RRNL-/RRPL-/RRRL-	RXRN-BD15
Economizers (Sideflow Only)	RRNL-/RRPL-/RRRL-	RXRE-CCA30 (3 Position) RXRD-CCM10 (Fully Modulating)
Economizers (Downflow Only)	RRNL-/RRPL-/RRRL-	RXRE-CAA30 (3 Position) RXRD-CAM10 (Fully Modulating)
Fresh Air Damper	RRNL-/RRPL-/RRRL-	RXRF-FAB1 (Motorized-35%) RXRF-FAA1 (Fixed-35%)
Rectangular to Round Transition (Downflow)	RRNL-/RRPL-/RRRL-	RXMC-CA02 (16" [406 mm] Ducts) RXMC-CA03 (18" [457 mm] Ducts)
Filter Kit	RRNL-/RRPL-/RRRL-	RXRY-B01
Sideflow Rectangular to Round Transition	RRNL-/RRPL-/RRRL-	RXMC-BA01
LP Conversion Kits	RRNL-/RRPL-/RRRL-C (2 Stage)	RXGJ-EP84W (White-Rodgers Gas Valve) RXGJ-EP85H (Honeywell Gas Valve) RXGJ-FP25
Low Ambient Control	RRNL-/RRPL-/RRRL-	RXRZ-B01
High Pressure Control	RRNL-/RRPL-/RRRL- ²	RXAB-E01
Low Pressure Control	RRNL-/RRPL-/RRRL- ²	RXAC-C01
Canadian High Altitude Kit (for Natural Gas only ¹)	RRNL-/RRPL-/RRRL-	RXR-AXH01
Dehumidistat	RRRL-	41-25066-02 (Available through PROSTOCK)

¹ If a particular unit is to be converted to operate on LP (propane) for elevations above 2000 ft. [609.6 m] in Canada, the existing Natural Gas to LP Conversion Kits for the subject models already contain the necessary orifices and instructions to de-rate the input for 2000-4500 ft. [609.6-1371.6 m] Canadian applications.

² High and low pressure switches are standard for RRRL Models and for RRNL/RRPL 5 Ton models.

[] Designates Metric Conversions

COMMON SUPPLY/RETURN CONCENTRIC AIR DIFFUSER

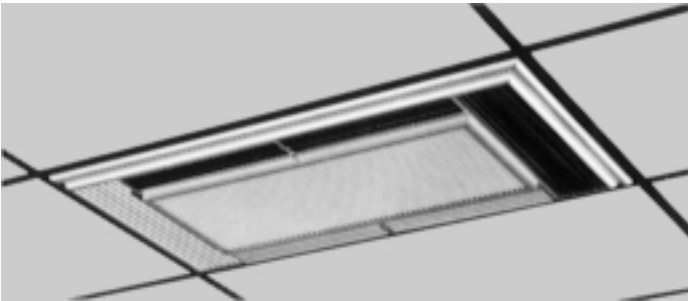

SUPPLY/RETURN DIFFUSER



Designed to convert a side by side or an over and under arrangement into a concentric distribution of air. The diffuser is flush mounted, completely insulated, assembled, and internally baffled to provide four way supply air distribution with a center return. To make the assembly complete and ready to fit into a 2' [0.61 m] x 4' [1.22 m] suspended ceiling grid, the diffuser includes adjustable supply louvers, hanging rings, anti-sweat gasket, and round flanges for use with flexible ducts.

Model No.	Diameter Inches [mm]	Shipping Wt. Lbs. [kg]	Dimension A Inches [mm]
RXRN-BD15	16 [406]	90 [40.82]	20 ¹ / ₂ [521]

DIFFUSER INSTALLS FLUSH WITH CEILING

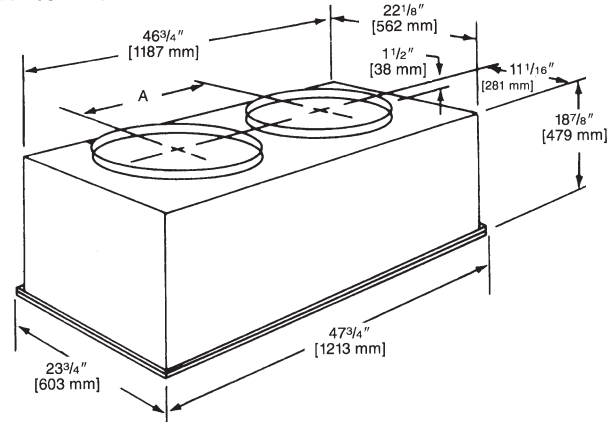

NOTE: The location of the combination supply and return diffuser should not exceed 10 feet [3.05 m] above the floor level for units @ 1000 CFM [472 L/s] or less and 12 [3.66 m] to 14 feet [4.27 m] above the floor level for units with CFM greater than 1000 [472 L/s]. If the diffuser is installed with a greater distance than recommended above, the supply air may become stratified above the required comfort area causing uncomfortable conditions.

AIRFLOW/PRESSURE DROP INFORMATION (INCHES W.C. [kPa])

Accessory	Approximate CFM [L/s]-Supply Air			
	1300 [614]	1575 [743]	1800 [850]	2200 [1038]
Plenum & Supply/Return Duct	.07 [.017]	.10 [.024]	.12 [.030]	.17 [.042]
Diffuser	.09 [.022]	.13 [.032]	.16 [.040]	.24 [.060]
Economizer	.06 [.015]	.09 [.022]	.11 [.027]	.17 [.042]

SUPPLY AIR/PERFORMANCE

Diffuser Airflow CFM [L/s]	Range of Throw Ft. [m]
800 [378]-1200 [566]	14 [4.27]-16 [4.88]
1600 [755]-2000 [944]	18 [5.49]-28 [8.53]

THERMOSTATS

100-Series *
Non-Programmable

200-Series *
Programmable

300-Series *
Deluxe
Programmable

500-Series *
Communicating/
Programmable

400-Series *
Special Applications/
Programmable

Brand	Unique Model Number Prefix	Descriptor (3 Characters)	Series (3 Characters)	System (2 Characters)	Type (2 Characters)
RHC	-	TST	101	GE	MS
RHC=Rheem		TST=Thermostat	100=Non-Programmable 200=Programmable 300=Deluxe Programmable 400=Special Applications/ Programmable 500=Communicating/ Programmable	GE=Gas/Oil/Electric HP=Heat Pump MD=Modulating Furnace DF=Dual Fuel UN=Universal AC/HP/GE CM=Communicating	SS=Single-Stage MS=Multi-Stage

* Photos are representative. Actual models may vary.

For detailed thermostat match-up information, see specification sheet form number T11-001.

DUCT ADAPTERS RECTANGULAR TO ROUND TRANSITIONS (DOWNFLOW)

RXMC-CA02

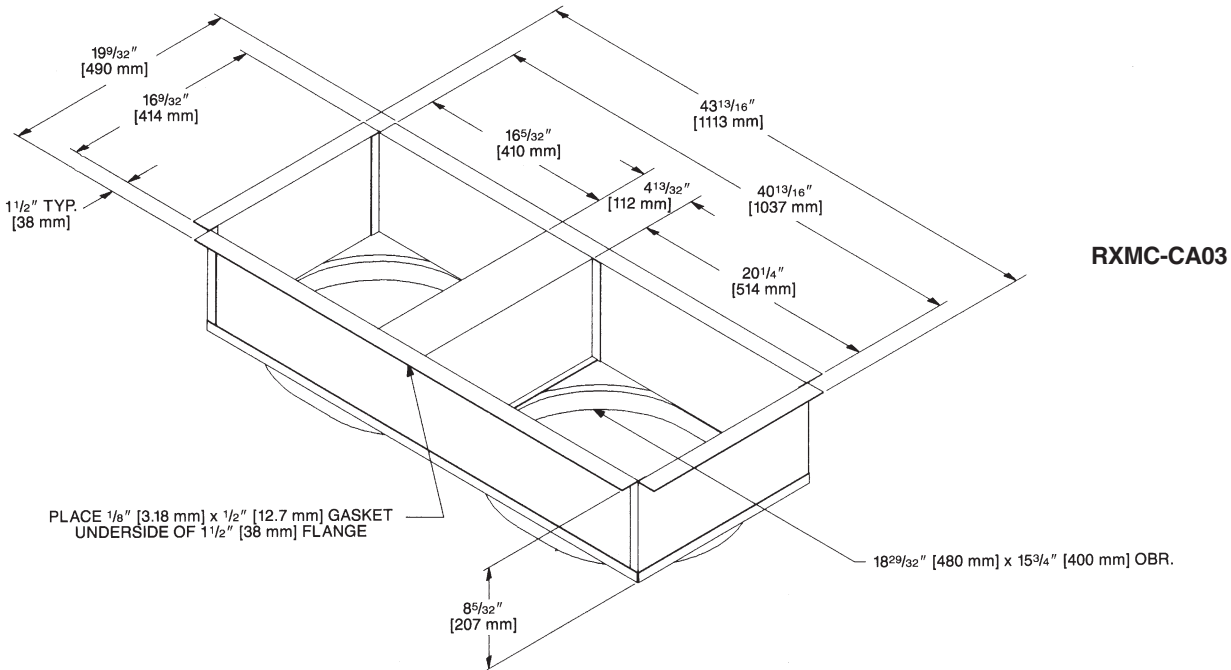
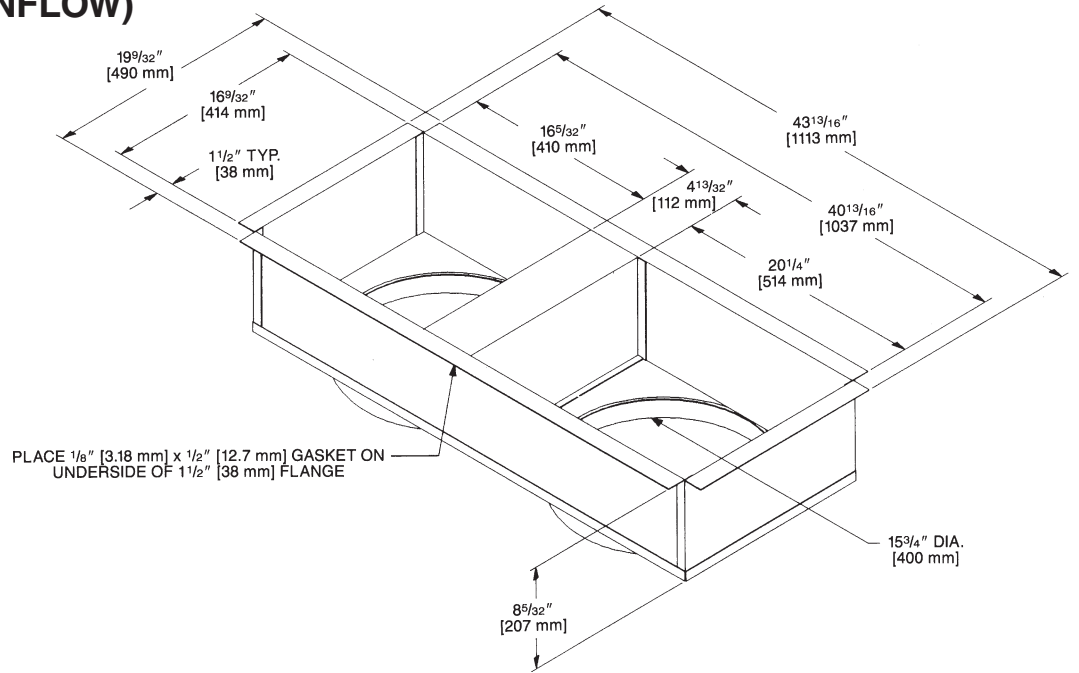

RXMC-CA03

[] Designates Metric Conversions

FRESH AIR DAMPER

RXRF-FAA1 (Fixed - 0-35%)

The 0-35% manual outside Air Damper is designed to replace the unit return air duct cover. No drilling or damper assembly is required. The amount of outside air (0-35%) is controlled by simply adjusting the side damper.

RXRF-FAB1 (Motorized - 0-35%)

The 0-35% motorized outside Air Damper is designed to replace the unit return air duct cover. No drilling or damper assembly is required. The control motor opens the adjustable side damper when the unit blower motor is energized.

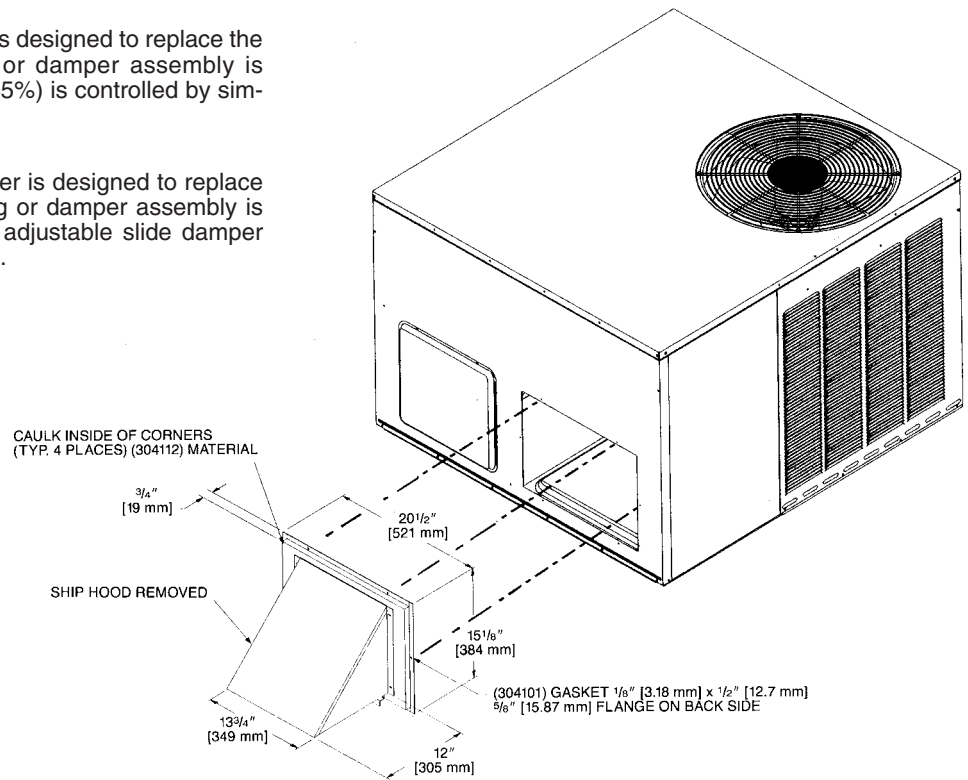

ECONOMIZERS

RXRE-CAA30 (3 Position) and RXRD-CAM10 (Fully Modulating)

RXRE-CAA30 (3 Position)

Provided with enthalpy control, and mixed air sensor. Settings include fully open, fully closed and adjustable mid point.

RXRD-CAM10 (Fully Modulating)

Provided with enthalpy control, mixed air sensor and minimum position potentiometer for proportioning (modulating) the amount of fresh air.

NOTE: See economizer installation instructions for correct filter access door.

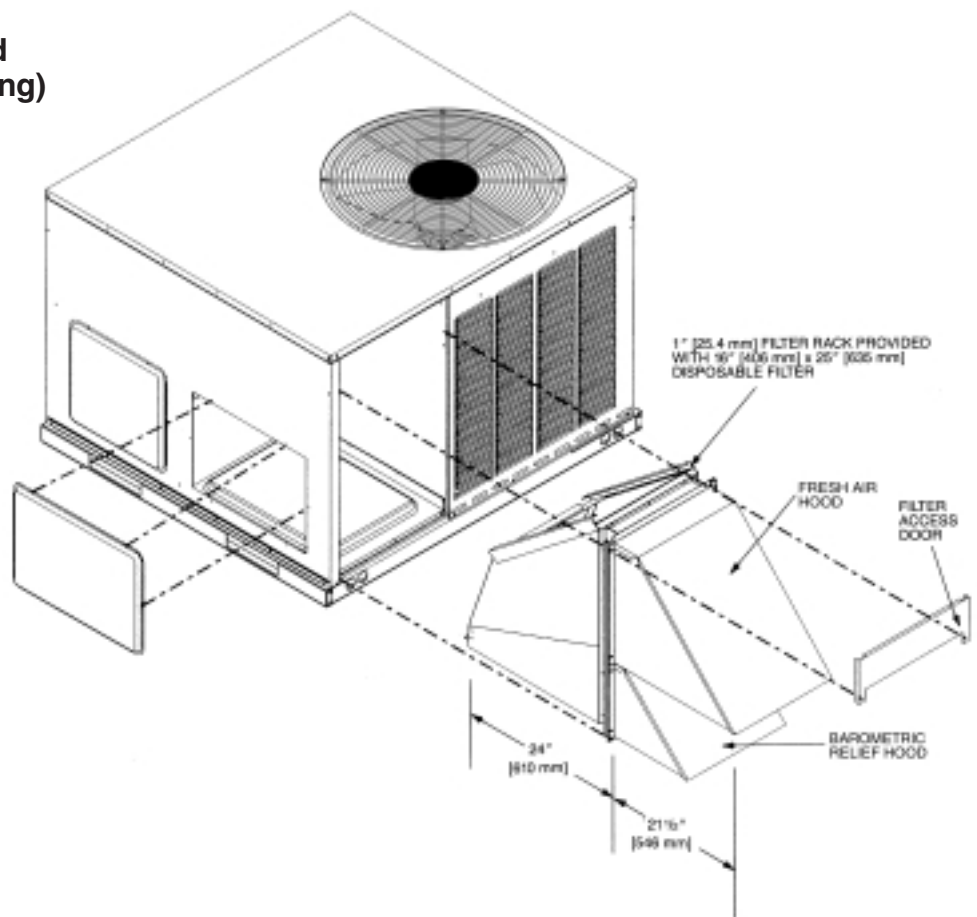

[] Designates Metric Conversions

ECONOMIZERS

RXRD-CCM10 (Fully Modulating) and RXRE-CCA30 (3 Position) Horizontal Application

RXRD-CCM10 (Fully Modulating)

Provided with enthalpy control, mixed air sensor and minimum position potentiometer for proportioning (modulating) the amount of fresh air.

RXRE-CCA30 (3-Position)

Has outdoor air sensor, minimum position potentiometer and mixed air sensor to provide three damper positions.

[] Designates Metric Conversions

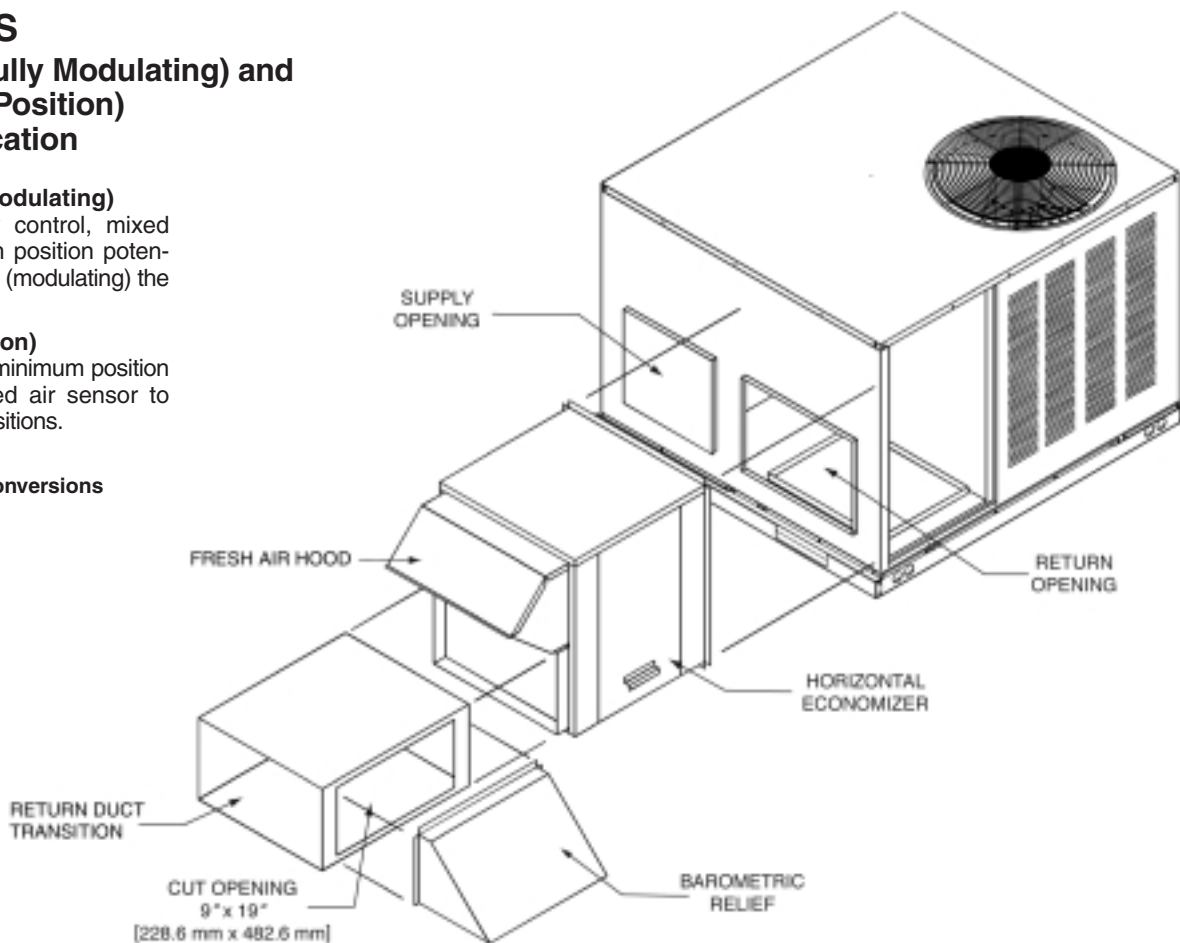

FILTER KIT INSTALLATION RXRY-B01

For use in either
vertical or horizontal
discharge.

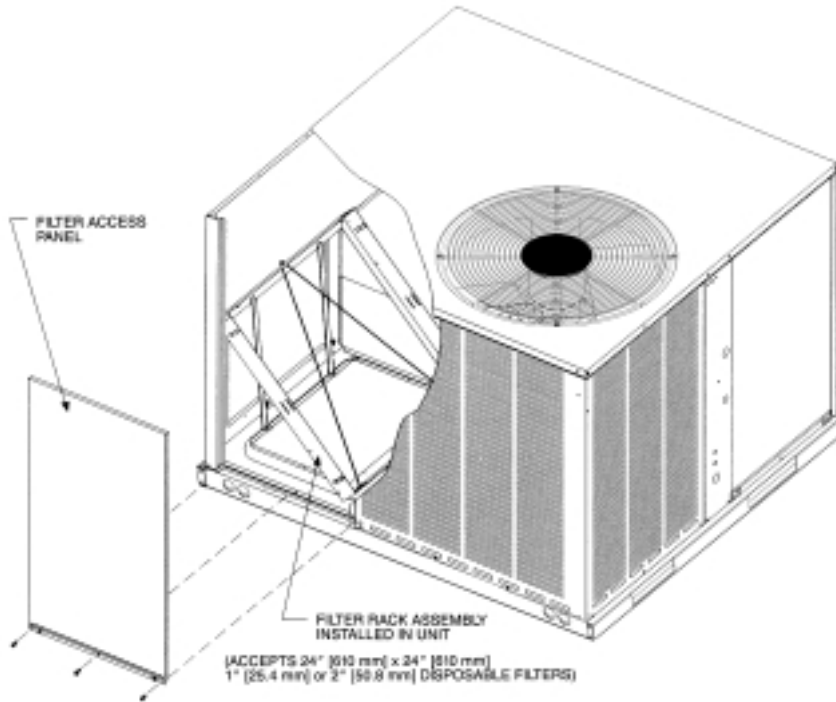

Airflow Pressure Drop, Inches W.C. [kPa]		
CFM [L/s]	1" Filter	2" Filter
500 [236]	.02 [.0050]	.03 [.0075]
600 [283]	.02 [.0050]	.03 [.0075]
700 [330]	.03 [.0075]	.04 [.0101]
800 [378]	.04 [.0101]	.05 [.0124]
900 [425]	.05 [.0124]	.06 [.0149]
1000 [472]	.07 [.0174]	.08 [.0199]
1100 [519]	.08 [.0199]	.09 [.0224]
1200 [566]	.10 [.0249]	.12 [.0299]
1300 [614]	.13 [.0324]	.15 [.0373]
1400 [661]	.16 [.0398]	.19 [.0473]
1500 [708]	.19 [.0473]	.21 [.0523]
1600 [755]	.20 [.0498]	.23 [.0572]
1700 [802]	.21 [.0523]	.24 [.0598]
1800 [850]	.22 [.0548]	.25 [.0623]
1900 [897]	.24 [.0598]	.27 [.0672]
2000 [944]	.26 [.0647]	.29 [.0722]

[] Designates Metric Conversions

DUCT ADAPTER SIDEFLOW SQUARE TO ROUND TRANSITION RXMC-A01

Adapts the side rectangular supply and return openings to 14" [356 mm] diameter round openings. Adapters provided with same finish as unit and also provided with thermal insulation.

[] Designates Metric Conversions

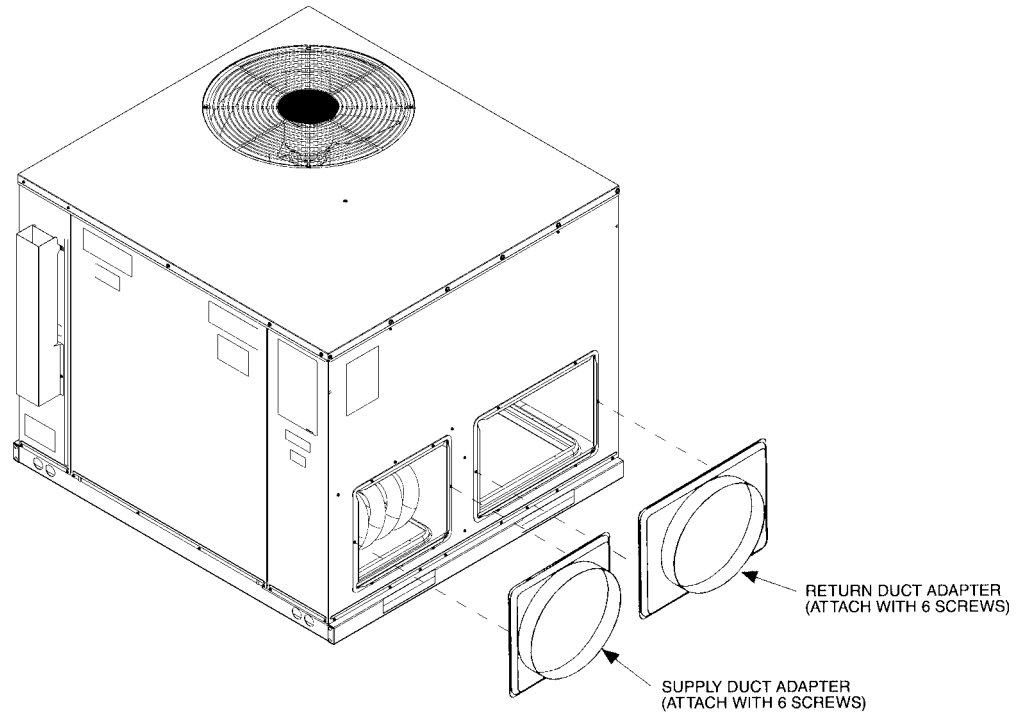

ROOFCURB (Full Perimeter)

RXSG-AAA08, RXSG-AAA14 and RXSG-AAA24

Hinged corners make for fast, easy set-up.

NOT for use with RQKA/RQLA/RQMA Package Heat Pumps.

RXSG-AAA08
(8" [203 mm] High)

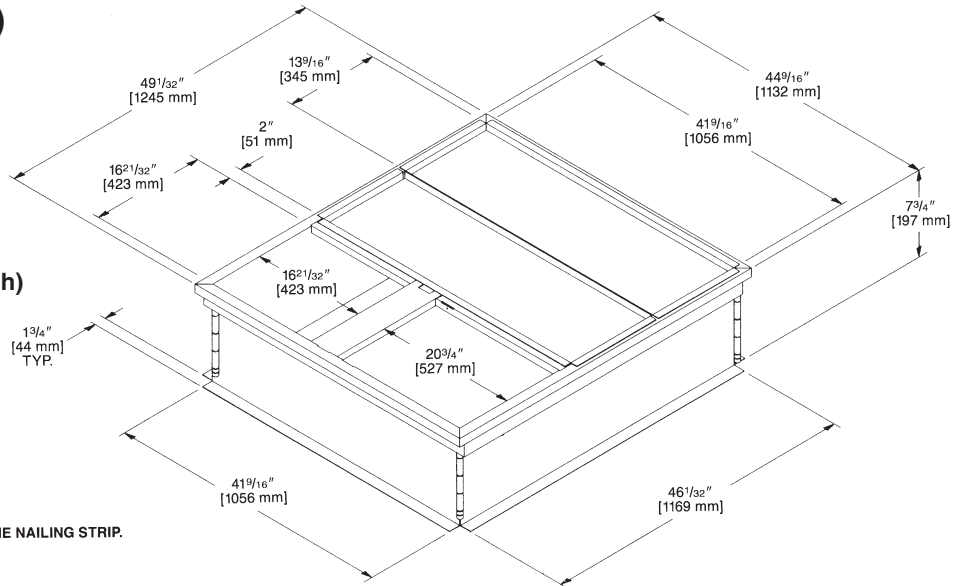

NOTE: PERIMETER OF ROOFCURB IS SUPPLIED WITH A NOMINAL 1" [25.4 mm] x 4" [102 mm] PINE NAILING STRIP.

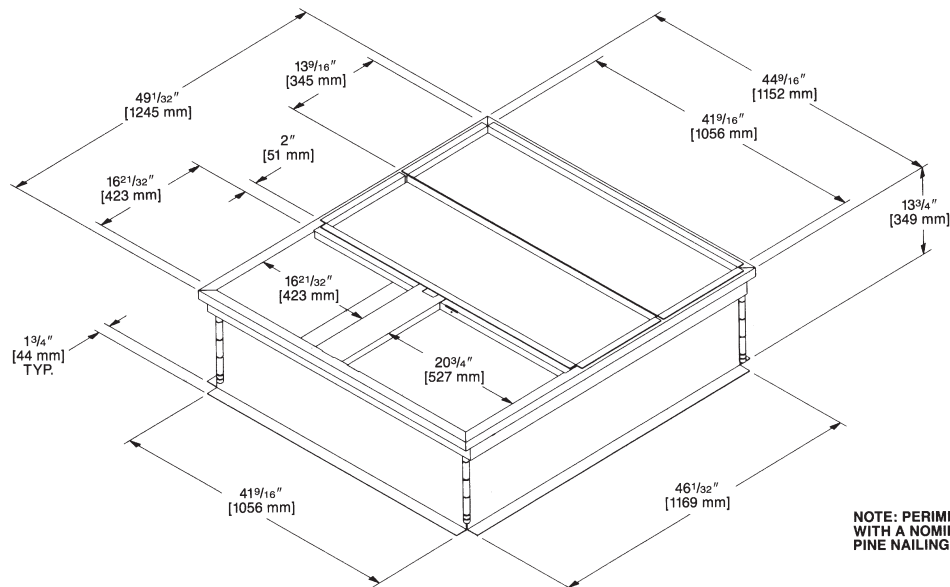

RXSG-AAA14
(14" [356 mm] High)

NOTE: PERIMETER OF ROOFCURB IS SUPPLIED WITH A NOMINAL 1" [25.4 mm] x 4" [102 mm] PINE NAILING STRIP.

RXSG-AAA24
(24" [610 mm] High)

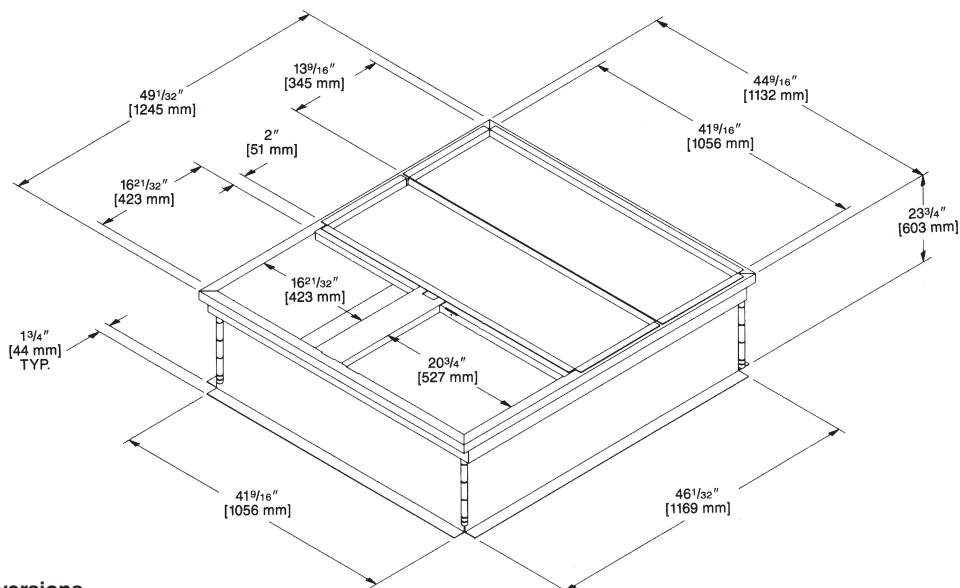

[] Designates Metric Conversions

PACKAGE AIR CONDITIONERS & PACKAGE GAS/ELECTRIC UNITS ROOFCURB INSTALLATION (Full Perimeter)

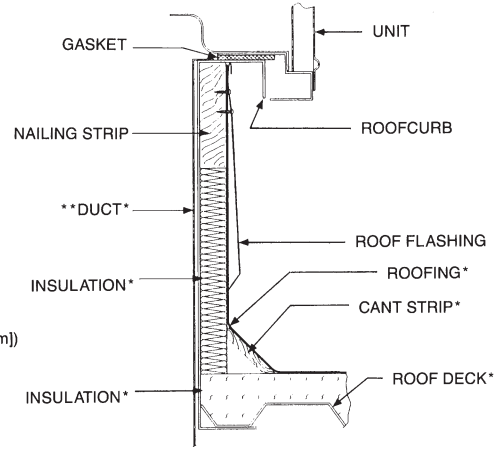
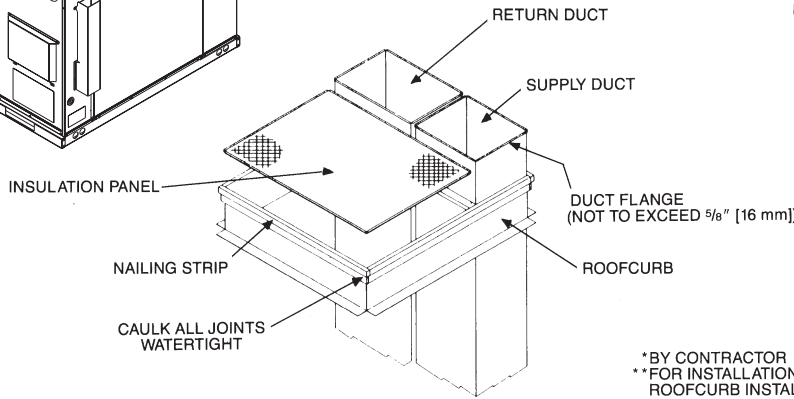
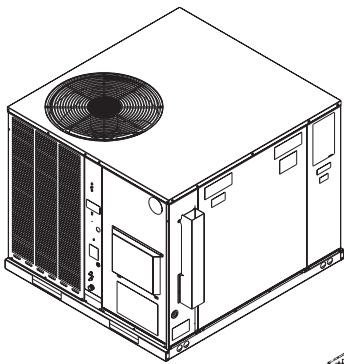

*BY CONTRACTOR
**FOR INSTALLATION OF DUCT AS SHOWN, USE RECOMMENDED DUCT SIZES FROM ROOFCURB INSTALLATION INSTRUCTIONS. FOR DUCT FLANGE ATTACHMENT TO UNIT, SEE UNIT INSTALLATION INSTRUCTIONS FOR RECOMMENDED DUCT SIZES.

ROOFCURB ADAPTERS

Fabricated from galvanized steel to adapt the New cabinet to the old style curb. All are furnished with a New gasket.

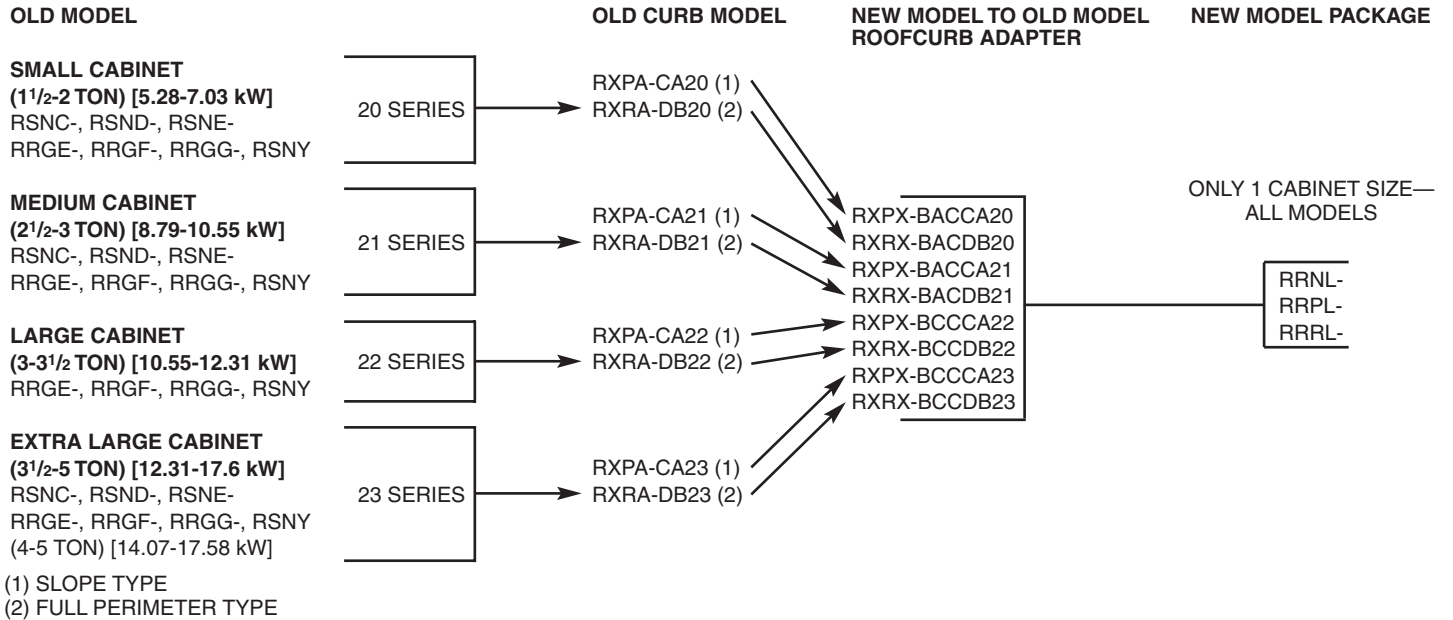

(1) SLOPE TYPE
(2) FULL PERIMETER TYPE

[] Designates Metric Conversions

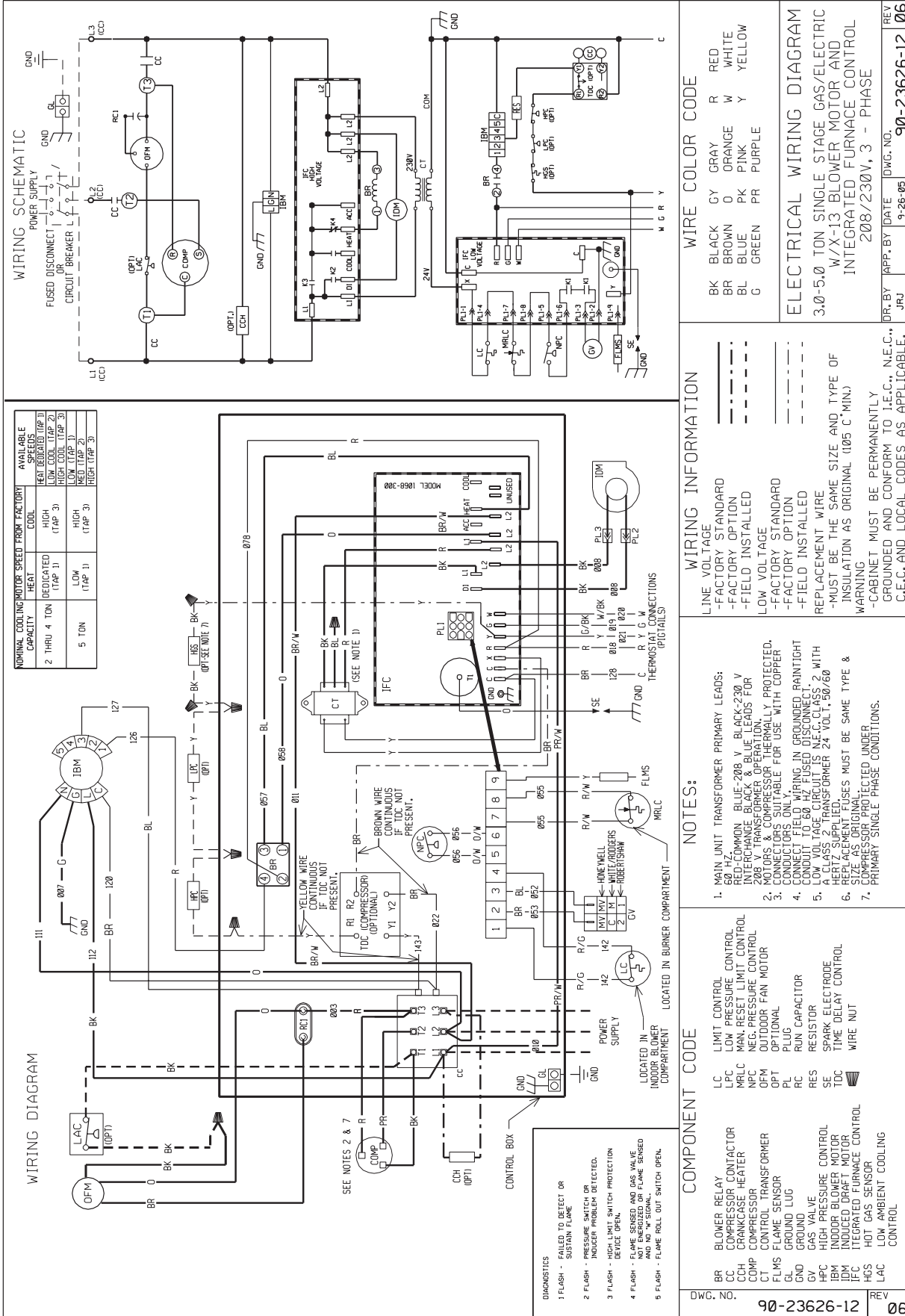

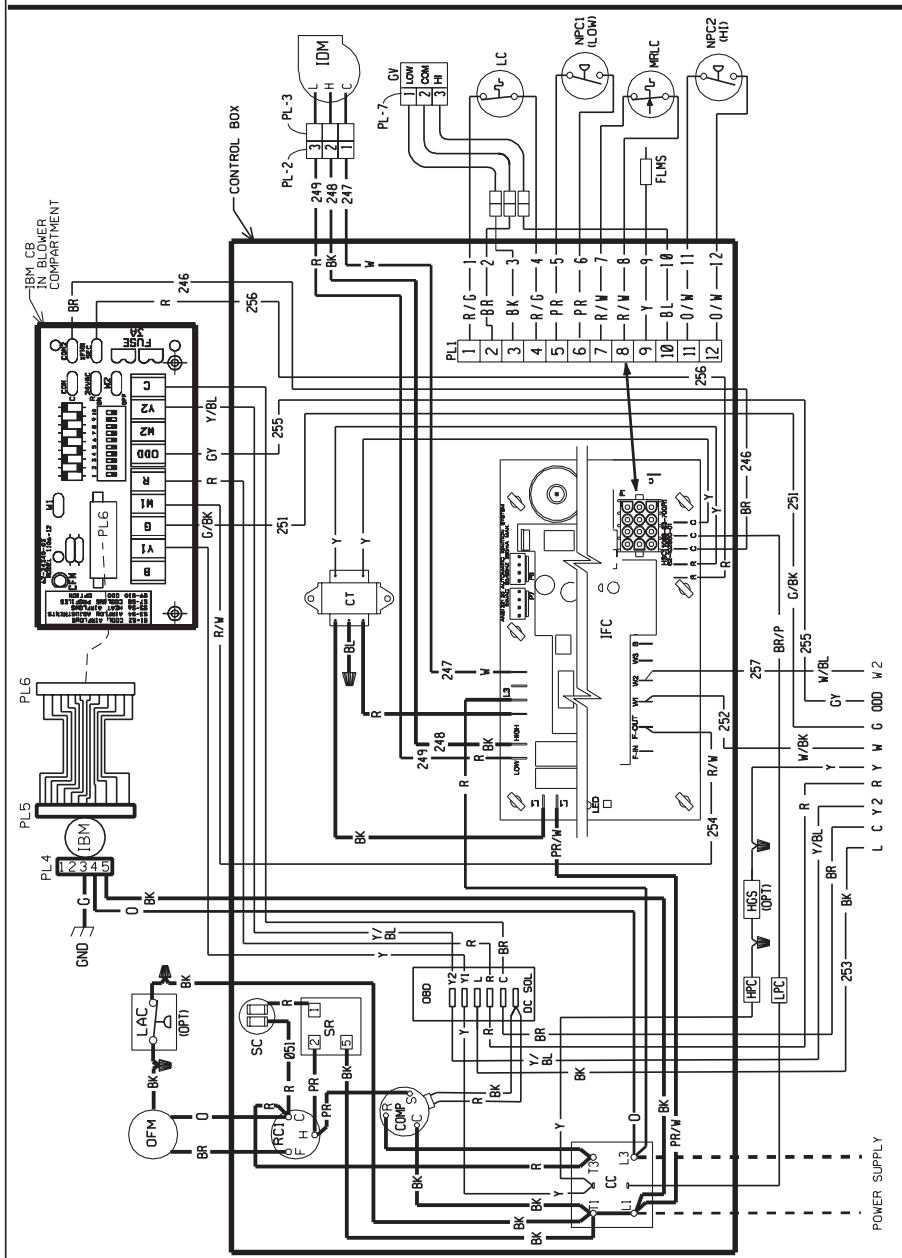
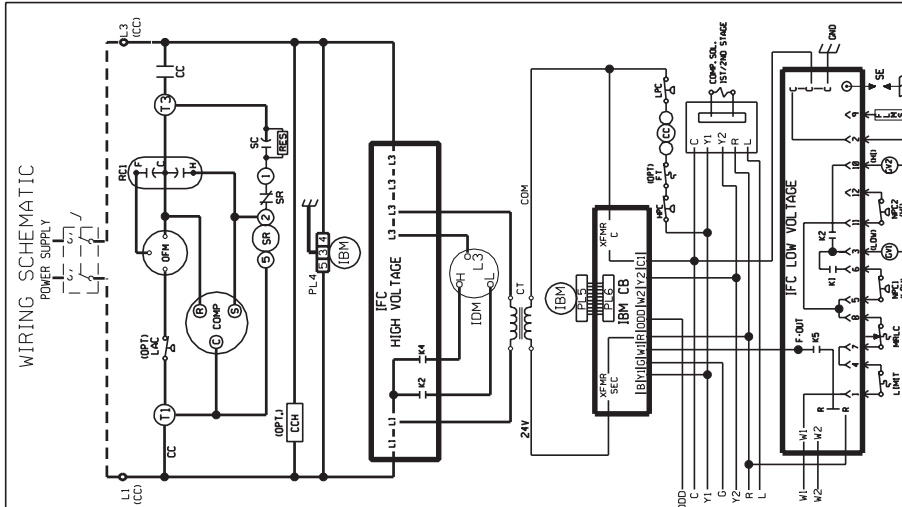

BEFORE PURCHASING THIS APPLIANCE, READ IMPORTANT ENERGY COST AND EFFICIENCY INFORMATION AVAILABLE FROM YOUR RETAILER.

GENERAL TERMS OF LIMITED WARRANTY

Rheem will furnish a replacement for any part of this product which fails in normal use and service within the applicable periods stated, in accordance with the terms of the limited warranty.

Heat Exchanger

- Factory StandardTen (10) Years
- Stainless Steel/1-Phase & 3-Phase Models
- Commercial ApplicationTwenty (20) Years
- Stainless Steel/1-Phase Models
- Residential ApplicationLimited Lifetime

***For Complete Details of the Limited Warranty, Including Applicable Terms and Conditions, See Your Local Installer or Contact the Manufacturer for a Copy.**

Compressor:

- 13, 14 & 16 SEER 1 & 3-Phase Models
(Commercial Applications).....Five (5) Years
- 13, 14 & 16 SEER 1-Phase Models
(Residential Applications)Ten (10) Years
- Any Other Part**
- 16 SEER 1-Phase Models
(Residential Applications)Ten (10) Years
- 13 & 14 SEER Conditional Parts*
(Registration Required –
Residential Applications)Ten (10) Years
- 1 & 3-Phase Models
(Commercial Applications)One (1) Year

Before proceeding with installation, refer to installation instructions packaged with each model, as well as complying with all Federal, State, Provincial, and Local codes, regulations, and practices.

**Rheem Heating,
Cooling and
Water Heating**

P.O. Box 17010, Fort Smith, AR 72917



"In keeping with its policy of continuous progress and product improvement, Rheem reserves the right to make changes without notice."