



## Ruud High Efficiency Air Handler equipped with *Comfort Control<sup>2</sup> System™*



### RHPN- Series

High Efficiency ECM Motor

Efficiencies up to 18 SEER



- Includes an energy efficient ECM Motor, that slowly ramps its speed up for quiet operation and enhanced customer satisfaction.
- Versatile 4-way convertible design for upflow, downflow, horizontal left and horizontal right applications.
- Nominal airflow up to 1.0" external static pressure.
- Factory-installed high efficiency indoor coil.
- Sturdy cabinet construction with 1.0 inch [25.4 mm] of foil faced insulation for excellent sound and insulating characteristics.
- Field-installed auxiliary electric heater kits provide exact heat for indoor comfort. Kits include circuit breakers which meet U.L. and cUL requirements for service disconnect.
- Dip switch settings for selectable, customized cooling airflow over a wide variety of applications when wired in 24V conventional configurations.
- On-demand dehumidification terminal that adjusts airflow to help control humidity for unsurpassed comfort in cooling mode.
- External filter required.
- Advanced controls provide more comfort and diagnostic options.
- Blower automatically self-configures and no dip switch settings are required when installed with a communicating outdoor unit and a 500-Series Ruud thermostat.

# TABLE OF CONTENTS

Engineering Features .....	3
Model Number Identification .....	4
Dimensional Data.....	5
Airflow Directional Data .....	6
Airflow Performance Data .....	7
Electrical Data .....	8-9
Electrical Wiring .....	10
Accessories .....	10
Limited Warranty .....	11

## Engineering Features

### RHPN- Series

- Quiet, efficient ECM motor technology providing nominal airflow up to 1.0 inch [25 kPa] of external static pressure.
- Interface board with dip switches conveniently located in the blower compartment allows for precise, field selectable airflow to meet the requirements of particular applications.
- Selectable continuous fan “on” options.
- The most compact unit design available.
- Attractive pre-painted cabinet exterior.
- Rugged steel cabinet construction, designed for added strength and versatility.
- 1.0" foil faced insulation mechanically retained in blower compartment.
- Four leg rubber insulated motor mount.
- Field-installed auxiliary heater kit includes circuit breakers that meet UL and cUL requirements as a service disconnect switch.
- Blower housing with integrated controls, motor and blower. Slide out design for service and maintenance convenience.
- Field convertible for vertical upflow, vertical downflow, horizontal left hand or right hand air supply.
- Combustible floor base accessory available when required for downflow installations on combustible floors.
- Advanced controls provide more comfort and diagnostic options.
- Indoor coil design provides low air side pressure drop, high performance and extremely compact size. All coils come with PVC condensate elbow standard.
- Coils are constructed of aluminum fins bonded to internally grooved copper tubing.
- Molded polymer corrosion resistant condensate drain pan is provided on all indoor coils.
- Supply duct flanges provided as standard on air handler cabinet.
- Provisions for field electrical connections available from either side or top of the air handler cabinet.
- Connection point for high voltage wiring is inside the air handler cabinet. Low voltage connection is made on the outside of the air handler cabinet.
- Concentric knockouts are provided for power connection to cabinet. Installer may pull desired hole size up to 2 inches [51 mm] for 1½ inch [38 mm] conduit.
- Internal checked TX valves are used on the Heat Pump indoor coil for more quiet refrigerant metering.
- Front refrigerant and drain connections.

[ ] Designates Metric Conversions



## Model Number Identification

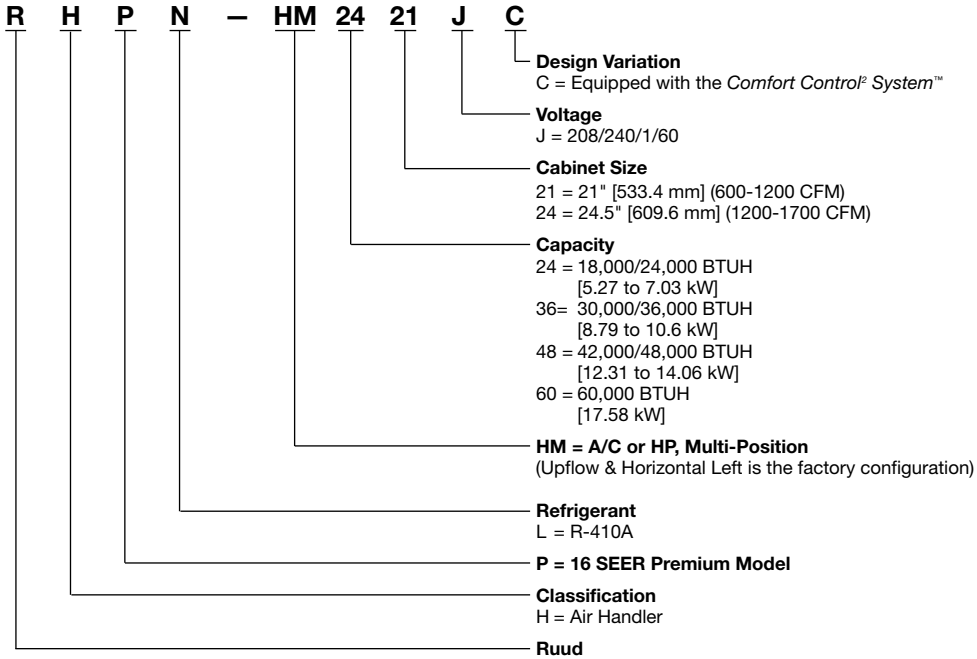

[ ] Designates Metric Conversions

Available Models
RHPN-HM2421JC
RHPN-HM3624JC
RHPN-HM4824JC
RHPN-HM6024JC

## Unit Dimensions

ELECTRICAL CONNECTIONS  
MAY EXIT TOP OR EITHER SIDE  
HIGH VOLTAGE CONNECTION 7/8" [22.2 mm],  
1 1/8" [27.8 mm], 1 3/8" [50 mm] DIA. KNOCKOUTS.

LOW VOLTAGE CONNECTION  
5/8" [15.9 mm] AND 7/8" [22.2 mm] KNOCKOUT

AUXILIARY DRAIN CONNECTION  
3/4" [19.1 mm] FEMALE PIPE THREAD (NPT)  
HORIZONTAL APPLICATION ONLY

PRIMARY DRAIN CONNECTION  
3/4" [19.1 mm] FEMALE PIPE THREAD (NPT)

AUXILIARY DRAIN CONNECTION  
3/4" [19.1 mm] FEMALE PIPE THREAD (NPT)  
UPFLOW/DOWNFLOW APPLICATION ONLY

LIQUID LINE CONNECTION  
COPPER (SWEAT)

VAPOR LINE CONNECTION  
COPPER (SWEAT)

SUPPLY AIR ↑

NOTE: 24" CLEARANCE REQUIRED IN FRONT OF  
UNIT FOR FILTER AND COIL MAINTENANCE.

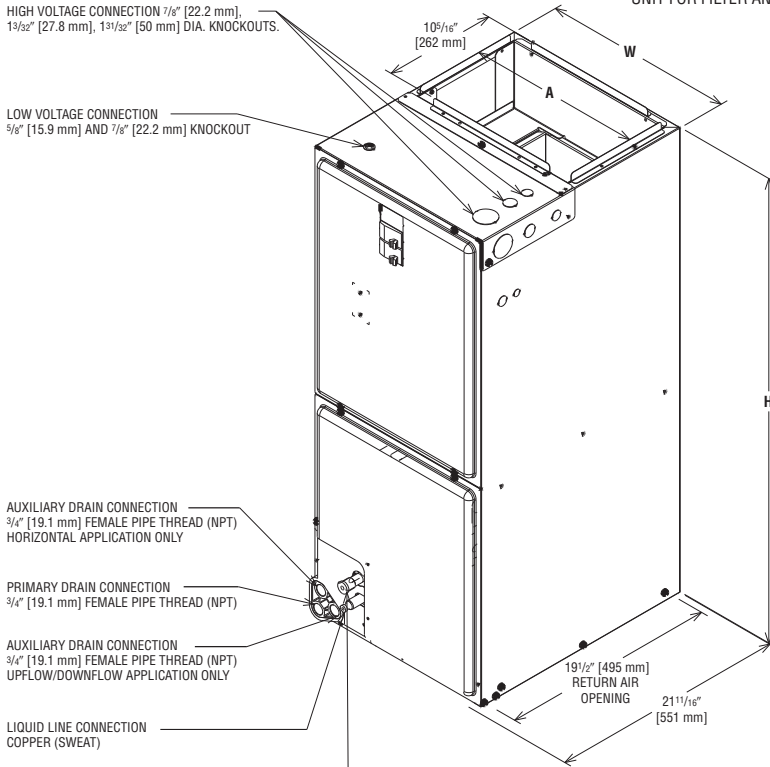

UPFLOW UNIT SHOWN:  
UNIT MAY BE INSTALLED UPFLOW, DOWNFLOW,  
HORIZONTAL RIGHT OR LEFT AIR SUPPLY.

## Return Air Opening Dimensions

Model Cabinet Size	Return Air Opening Width (Inches)	Return Air Opening Depth/Length (Inches)
21	19 3/8	19 1/2
24	22 7/8	19 1/2

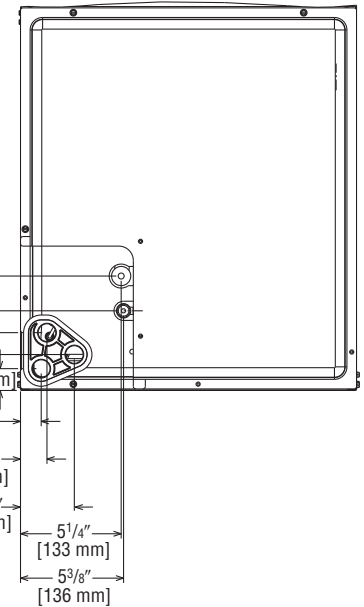

UPFLOW UNIT SHOWN:  
UNIT MAY BE INSTALLED UPFLOW,  
DOWNFLOW, HORIZONTAL RIGHT  
OR LEFT AIR SUPPLY.

[ ] Designates Metric Conversions

( ) Designates Unit with Double Coil Cabinet

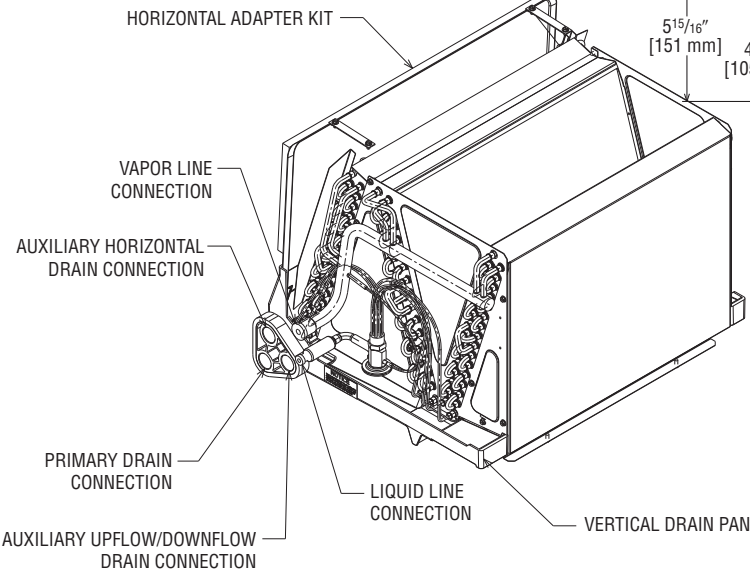

AUXILIARY UPFLOW/DOWNFLOW  
DRAIN CONNECTION

## Unit Dimensions & Weights

Model Size RHPN-	Refrigerant Connections		Unit Width "W" In. [mm]	Unit Height "H" In. [mm]	Supply Duct "A" In. [mm]	Nominal Coil Airflow [L/s]				Unit Weight/Shipping Weight (Lbs.) [kg]
	Sweat (in.) [mm] ID					1st Stage		2nd Stage		
	Liquid	Vapor				ODD*	Normal	ODD*	Normal	
2421	3/8 [9.53]	3/4 [19.05]	21 [533]	42 1/2 [1080]	19 1/2 [495]	480 [227]	625 [295]	640 [302]	775 [366]	92/106 [42/48]
3624	3/8 [9.53]	7/8 [22.23]	24 1/2 [622]	55 1/2 [1410]	23 [584]	725 [342]	825 [389]	975 [460]	1175 [555]	181/198 [82/90]
4824	3/8 [9.53]	7/8 [22.23]	24 1/2 [622]	55 1/2 [1410]	23 [584]	825 [389]	950 [448]	1000 [472]	1175 [555]	162/180 [73/81]
6024	3/8 [9.53]	7/8 [22.23]	24 1/2 [622]	55 1/2 [1410]	23 [584]	960 [453]	1200 [566]	1280 [804]	1625 [767]	181/198 [82/90]
						1040 [491]	1375 [649]	1360 [642]	1675 [791]	

\*Maximum dehumidification airflow.

## Airflow Directional Data

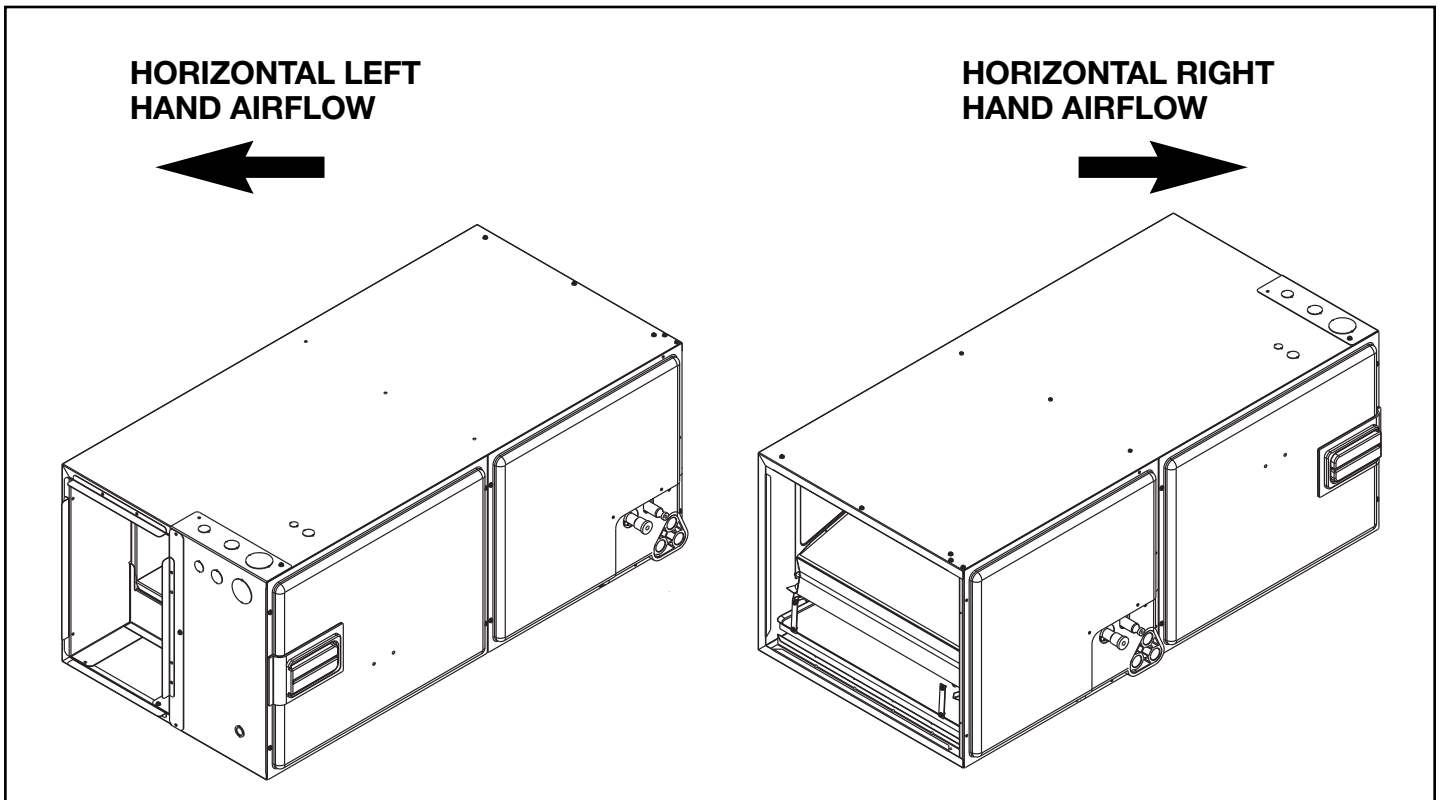
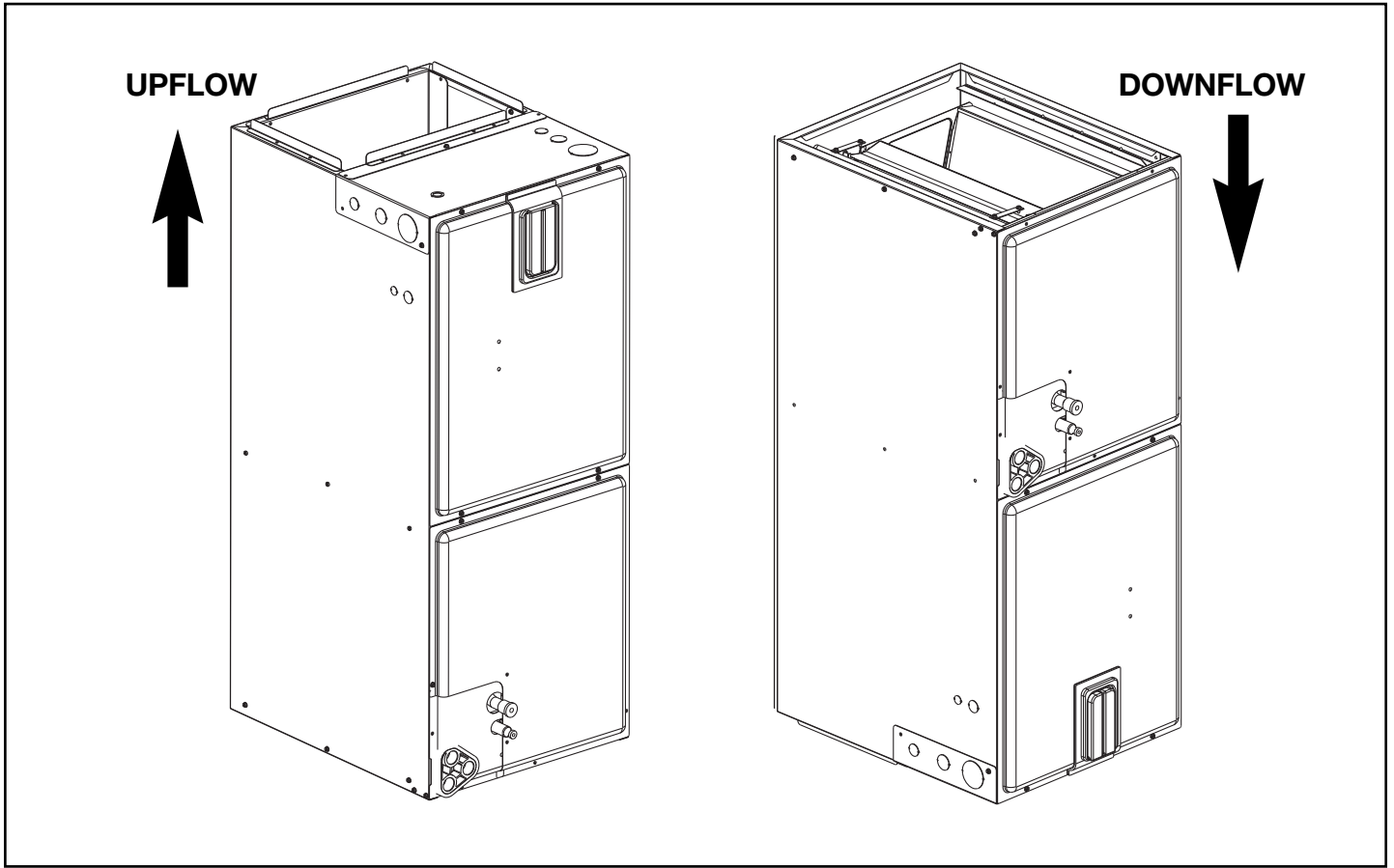

## Airflow Performance

Airflow performance data is based on cooling performance with a coil and no filter in place. Select performance table for appropriate unit size, voltage and number of electric heaters to be used. Make sure external static applied to unit allows operation within the minimum and maximum limits shown in table

below for both cooling and electric heat operation. For optimum blower performance, operate the unit in the .3 [8 mm] to .7 inches [18 mm] W.C. external static range. Units with coils should be applied with a minimum of .1 inch [3 mm] W.C. external static range.

## Airflow Performance Data

Air Handler	Outdoor Unit	Cabinet Size	Blower		Nominal Airflow CFM	External Static Pressure - In. W.C. CFM [L/s] Air Delivery/RPM/Watts-230 Volts											
			Size Motor HP	Unit Operation		External Static Pressure - Inches W.C. [kPa]											
						0.10	0.20	0.30	0.40	0.50	0.60	0.70	0.80	0.90	1.00		
RHPN-HM2421	RARL-024 or RASL-024	21	10 x 8 1/3	First Stage	600	CFM	550 [260]	575 [271]	600 [283]	600 [283]	625 [295]	625 [295]	625 [295]	600 [283]	575 [271]	550 [260]	
						RPM	455	540	620	695	760	825	885	940	985	1030	
						Watts	40	55	70	85	105	120	135	150	170	185	
				Second Stage	775	CFM	775 [366]	775 [366]	775 [366]	800 [378]	800 [378]	825 [389]	825 [389]	825 [389]	825 [389]	825 [389]	825 [389]
						RPM	540	615	685	750	810	870	925	975	1020	1065	
						Watts	70	90	115	135	160	180	205	225	250	270	
RHPN-HM3624	RARL-036 or RASL-036	24	11 x 11 3/4	First Stage	950	CFM	950 [448]	950 [448]	1000 [472]	975 [460]	975 [460]	975 [460]	925 [437]	925 [437]	925 [437]	925 [437]	
						RPM	495	555	610	665	720	770	820	865	910	955	
						Watts	95	115	140	165	185	210	240	265	290	320	
				Second Stage	1175	CFM	1150 [543]	1150 [543]	1175 [555]	1175 [555]	1175 [555]	1150 [543]	1150 [543]	1150 [543]	1125 [531]	1125 [531]	
						RPM	550	600	650	700	750	800	850	900	925	975	
						Watts	125	175	200	225	250	275	300	325	375	400	
	RASL-039	First Stage	825	CFM	825 [389]	825 [389]	875 [413]	875 [413]	850 [401]	850 [401]	825 [389]	825 [389]	800 [378]	800 [378]			
				RPM	455	515	575	630	680	730	780	830	875	915			
				Watts	70	90	115	135	155	180	205	230	255	280			
		Second Stage	1175	CFM	1150 [543]	1150 [543]	1175 [555]	1175 [555]	1175 [555]	1150 [543]	1150 [543]	1150 [543]	1125 [531]	1125 [531]			
				RPM	550	600	650	700	750	800	850	900	925	975			
				Watts	125	175	200	225	250	275	300	325	375	400			
RHPN-HM4824	RARL-048	24	11 x 11 3/4	First Stage	1200	CFM	1275 [602]	1275 [602]	1250 [590]	1250 [590]	1275 [602]	1250 [590]	1250 [590]	1225 [578]	1225 [578]	1225 [578]	
						RPM	533	593	649	702	752	798	841	881	917	950	
						Watts	131	161	191	221	250	279	307	335	363	390	
				Second Stage	1600	CFM	1650 [779]	1650 [779]	1675 [791]	1700 [802]	1700 [802]	1700 [802]	1675 [791]	1675 [791]	1675 [791]	1675 [791]	
						RPM	635	698	761	824	887	950	1013	1075	1120	1006	
						Watts	244	293	340	384	425	464	500	533	564	592	
	RASL-048	First Stage	1000	CFM	1000 [472]	1000 [472]	1025 [484]	1025 [484]	1000 [472]	1000 [472]	975 [460]	975 [460]	975 [460]	975 [460]			
				RPM	500	575	625	675	725	775	825	875	925	950			
				Watts	100	125	150	175	200	225	250	275	300	325			
		Second Stage	1600	CFM	1650 [779]	1650 [779]	1675 [791]	1700 [802]	1700 [802]	1700 [802]	1675 [791]	1675 [791]	1675 [791]	1675 [791]			
				RPM	635	698	761	824	887	950	1013	1075	1120	1006			
				Watts	244	293	340	384	425	464	500	533	564	592			
RHPN-HM6024	RARL-060	24	11 x 11 3/4	First Stage	1275	CFM	1275 [602]	1275 [602]	1275 [602]	1275 [602]	1275 [602]	1275 [602]	1250 [590]	1250 [590]	1250 [590]		
						RPM	577	633	687	738	786	831	874	914	951	986	
						Watts	159	189	218	248	279	310	341	372	404	436	
				Second Stage	1700	CFM	1625 [767]	1625 [767]	1650 [779]	1675 [791]	1675 [791]	1650 [779]	1650 [779]	1625 [767]	1625 [767]	1625 [767]	
						RPM	691	742	790	835	877	916	953	986	1016	1044	
						Watts	289	334	377	417	456	493	529	562	593	623	
	RASL-060	First Stage	1050	CFM	1050 [496]	1050 [496]	1075 [507]	1075 [507]	1050 [496]	1025 [484]	1025 [484]	1025 [484]	1025 [484]	1000 [472]			
				RPM	525	575	625	675	750	800	825	875	925	975			
				Watts	100	125	150	175	225	250	275	300	325	350			
		Second Stage	1700	CFM	1625 [767]	1625 [767]	1650 [779]	1675 [791]	1675 [791]	1650 [779]	1650 [779]	1625 [767]	1625 [767]	1625 [767]			
				RPM	691	742	790	835	877	916	953	986	1016	1044			
				Watts	289	334	377	417	456	493	529	562	593	623			

IMPORTANT: Observe airflow operating limits. Do not operate above 1.0 in. W.C. system external static.

[ ] Designates Metric Conversions

## Electrical Data

Model	HP [W]	Voltage	Phase	Hertz	RPM	Circuit Amps.	Minimum Circuit Ampacity	Maximum Circuit Protector
HM2421	1/3 [249]	208/230	1	60	300-1100	1.7	4.0	15
HM3624	3/4 [559]	208/230	1	60	300-1100	4.9	9.0	15
HM4824	3/4 [559]	208/230	1	60	300-1100	4.9	9.0	15
HM6024	3/4 [559]	208/230	1	60	300-1100	4.9	9.0	15

## Electrical Data – With Electric Heat

Installation of the U.L. Listed original equipment manufacturer provided heater kits listed in the following table is recommended for all auxiliary heating requirements.

Air Handler Model RHPN-	Heater Model No.	Heater kW (208/240V)	PH/HZ	No. Elements kW Per	Type Supply Circuit Single Circuit Multiple	Circuit Amps.	Motor Ampacity	Minimum Circuit Ampacity	Maximum Circuit Protection
21" /HM2421	RXBH-1724?05J	3.6/4.8	1/60	1 - 4.8	SINGLE	17.3/20.0	1.7	24/28	25/30
	RXBH-1724?07J	5.4/7.2	1/60	2 - 3.6	SINGLE	26.0/30.0	1.7	35/40	35/40
	RXBH-1724?10J	7.2/9.6	1/60	2 - 4.8	SINGLE	34.6/40.0	1.7	46/53	50/60
24" /HM3624	RXBH-1724?05J	3.6/4.8	1/60	1 - 4.8	SINGLE	17.3/20.0	4.9	28/32	30/35
	RXBH-1724?07J	5.4/7.2	1/60	2 - 3.6	SINGLE	26.0/30.0	4.9	39/44	40/45
	RXBH-1724?10J	7.2/9.6	1/60	2 - 4.8	SINGLE	34.6/40.0	4.9	50/57	50/60
	RXBH-1724A13J	9.4/12.5	1/60	3-4.17	SINGLE	45.1/52.1	4.9	63/72	70/80
	RXBH-1724A13J	3.1/4.2	1/60	1-4.17	MULTIPLE CKT 1	15.0/17.4	4.9	25/28	25/30
		6.3/8.3	1/60	2-4.17	MULTIPLE CKT 2	30.1/34.7	0.0	38/44	40/45
	RXBH-1724A15J	10.8/14.4	1/60	3-4.8	SINGLE	51.9/60.0	4.9	71/82	80/90
	RXBH-1724A15J	3.6/4.8	1/60	1 - 4.8	MULTIPLE CKT 1	17.3/20.0	4.9	28/32	30/35
		7.2/9.6	1/60	2 - 4.8	MULTIPLE CKT 2	34.6/40.0	0.0	44/50	45/50
	RXBH-1724A18J	12.8/17	1/60	3-5.68	SINGLE	61.6/70.8	4.9	84/95	90/100
	RXBH-1724A18J	4.3/5.7	1/60	1 - 5.68	MULTIPLE CKT 1	20.5/23.6	4.9	32/36	35/40
		8.7/11.3	1/60	2 - 5.86	MULTIPLE CKT 2	41.1/47.2	0.0	52/59	60/60
	RXBH-24A20J	14.4/19.2	1/60	4-4.8	SINGLE	69.2/80	4.9	93/107	100/110
	RXBH-24A20J	7.2/9.6	1/60	2 - 4.8	MULTIPLE CKT 1	34.6/40.0	4.9	50/57	50/60
		7.2/9.6	1/60	2 - 4.8	MULTIPLE CKT 2	34.6/40.0	0.0	44/50	45/50
24" /HM4824	RXBH-1724?05J	3.6/4.8	1/60	1 - 4.8	SINGLE	17.3/20.0	4.9	28/32	30/35
	RXBH-1724?07J	5.4/7.2	1/60	2 - 3.6	SINGLE	26.0/30.0	4.9	39/44	40/45
	RXBH-1724?10J	7.2/9.6	1/60	2 - 4.8	SINGLE	34.6/40.0	4.9	50/57	50/60
	RXBH-1724A13J	9.4/12.5	1/60	3-4.17	SINGLE	45.1/52.1	4.9	63/72	70/80
	RXBH-1724A13J	3.1/4.2	1/60	1-4.17	MULTIPLE CKT 1	15.0/17.4	4.9	25/28	25/30
		6.3/8.3	1/60	2-4.17	MULTIPLE CKT 2	30.1/34.7	0.0	38/44	40/45
	RXBH-1724A15J	10.8/14.4	1/60	3-4.8	SINGLE	51.9/60.0	4.9	71/82	80/90
	RXBH-1724A15J	3.6/4.8	1/60	1 - 4.8	MULTIPLE CKT 1	17.3/20.0	4.9	28/32	30/35
		7.2/9.6	1/60	2 - 4.8	MULTIPLE CKT 2	34.6/40.0	0.0	44/50	45/50
	RXBH-1724A18J	12.8/17	1/60	3-5.68	SINGLE	61.6/70.8	4.9	84/95	90/100
	RXBH-1724A18J	4.3/5.7	1/60	1 - 5.68	MULTIPLE CKT 1	20.5/23.6	4.9	32/36	35/40
		8.7/11.3	1/60	2 - 5.86	MULTIPLE CKT 2	41.1/47.2	0.0	52/59	60/60
	RXBH-24A20J	14.4/19.2	1/60	4-4.8	SINGLE	69.2/80	4.9	93/107	100/110
	RXBH-24A20J	7.2/9.6	1/60	2 - 4.8	MULTIPLE CKT 1	34.6/40.0	4.9	50/57	50/60
		7.2/9.6	1/60	2 - 4.8	MULTIPLE CKT 2	34.6/40.0	0.0	44/50	45/50
	RXBH-24A25J (4-ton only)	18.0/24.0	1/60	6-4.0	SINGLE	86.4/99.9	5.2	115/132	125/150
	RXBH-24A25J (4-ton only)	6.0/8.0	1/60	2-4.0	MULTIPLE CKT 1	28.8/33.3	5.2	43/49	45/50
		6.0/8.0	1/60	2-4.0	MULTIPLE CKT 2	28.8/33.3	0.0	36/42	40/45
6.0/8.0		1/60	2-4.0	MULTIPLE CKT 3	28.8/33.3	0.0	36/42	40/45	

- Supply circuit protective devices may be fuses or "HACR" type circuit breakers.
- Largest motor load is included in single circuit and multiple circuit 1.
- If non-standard fuse size is specified, use next size larger standard fuse size.
- J Voltage (230V) single phase air handler is designed to be used with single or three phase 230 volt electric heaters. In the case of connecting 3-phase power to the air handler terminal block without the heater, bring only two leads to the terminal block cap, insulate and fully secure the third lead.

[ ] Designates Metric Conversions



## Electrical Data – With Electric Heat (con't.)

Installation of the U.L. Listed original equipment manufacturer provided heater kits listed in the following table is recommended for all auxiliary heating requirements.

Air Handler Model RHPN-	Heater Model No.	Heater kW (208/240V)	PH/HZ	No. Elements kW Per	Type Supply Circuit Single Circuit Multiple	Circuit Amps.	Motor Ampacity	Minimum Circuit Ampacity	Maximum Circuit Protection
24" /HM6024	RXBH-1724?07J	5.4/7.2	1/60	2 - 3.6	SINGLE	26.0/30.0	4.9	39/44	40/45
	RXBH-1724?10J	7.2/9.6	1/60	2 - 4.8	SINGLE	34.6/40.0	4.9	50/57	50/60
	RXBH-1724A15J	10.8/14.4	1/60	3-4.8	SINGLE	51.9/60.0	4.9	71/82	80/90
	RXBH-1724A15J	3.6/4.8	1/60	1 - 4.8	MULTIPLE CKT 1	17.3/20.0	4.9	28/32	30/35
		7.2/9.6	1/60	2 - 4.8	MULTIPLE CKT 2	34.6/40.0	0.0	44/50	45/50
	RXBH-1724A18J	12.8/17	1/60	3-5.68	SINGLE	61.6/70.8	4.9	84/95	90/100
	RXBH-1724A18J	4.3/5.7	1/60	1 - 5.68	MULTIPLE CKT 1	20.5/23.6	4.9	32/36	35/40
		8.7/11.3	1/60	2 - 5.86	MULTIPLE CKT 2	41.1/47.2	0.0	52/59	60/60
	RXBH-24A20J	14.4/19.2	1/60	4-4.8	SINGLE	69.2/80	4.9	93/107	100/110
	RXBH-24A20J	7.2/9.6	1/60	2 - 4.8	MULTIPLE CKT 1	34.6/40.0	4.9	50/57	50/60
		7.2/9.6	1/60	2 - 4.8	MULTIPLE CKT 2	34.6/40.0	0.0	44/50	45/50
	RXBH-24A25J	18.0/24.0	1/60	6-4.0	SINGLE	86.4/99.9	4.9	115/131	125/150
	RXBH-24A25J	6.0/8.0	1/60	2-4.0	MULTIPLE CKT 1	28.8/33.3	4.9	43/48	45/50
		6.0/8.0	1/60	2-4.0	MULTIPLE CKT 2	28.8/33.3	0.0	36/42	40/45
		6.0/8.0	1/60	2-4.0	MULTIPLE CKT 3	28.8/33.3	0.0	36/42	40/45
	RXBH-24A20J	14.4/19.2	1/60	4-4.8	SINGLE	69.2/80	4.9	93/107	100/110
	RXBH-24A20J	7.2/9.6	1/60	2 - 4.8	MULTIPLE CKT 1	34.6/40.0	4.9	50/57	50/60
		7.2/9.6	1/60	2 - 4.8	MULTIPLE CKT 2	34.6/40.0	0.0	44/50	45/50
	RXBH-24A25J	18.0/24.0	1/60	6-4.0	SINGLE	86.4/99.9	4.9	115/131	125/150
	RXBH-24A25J	6.0/8.0	1/60	2-4.0	MULTIPLE CKT 1	28.8/33.3	4.9	43/48	45/50
		6.0/8.0	1/60	2-4.0	MULTIPLE CKT 2	28.8/33.3	0.0	36/42	40/45
		6.0/8.0	1/60	2-4.0	MULTIPLE CKT 3	28.8/33.3	0.0	36/42	40/45
	RXBH-24A30J	21.6/28.8	1/60	6-4.8	SINGLE	103.8/120	4.9	136/156	150/175
	RXBH-24A30J	7.2/9.6	1/60	2-4.8	MULTIPLE CKT 1	34.6/40.0	4.9	50/57	50/60
7.2/9.6		1/60	2-4.8	MULTIPLE CKT 2	34.6/40.0	0.0	44/50	45/50	
7.2/9.6		1/60	2-4.8	MULTIPLE CKT 3	34.6/40.0	0.0	44/50	45/50	

- Supply circuit protective devices may be fuses or "HACR" type circuit breakers.
- Largest motor load is included in single circuit and multiple circuit 1.
- If non-standard fuse size is specified, use next size larger standard fuse size.
- J Voltage (230V) single phase air handler is designed to be used with single or three phase 230 volt electric heaters. In the case of connecting 3-phase power to the air handler terminal block without the heater, bring only two leads to the terminal block cap, insulate and fully secure the third lead.

[ ] Designates Metric Conversions

## Electrical Wiring

### Power Wiring

- Field wiring must comply with the National Electrical Code (C.E.C. in Canada) and any applicable local ordinance.
- Supply wiring must be 75°C minimum copper conductors only.
- See electrical data for product Ampacity rating and Circuit Protector requirement.

## Accessories

### • Combustible Floor Base RXHB-

Model Cabinet Size	Combustible Floor Base Model Number
21	RXHB-21
24	RXHB-24

- **Jumper Bar Kit 3 Ckt. to 1 Ckt. RXBJ-A31** is used to convert single phase multiple three circuit units to a single supply circuit. Kit includes cover and screw for line side terminals.
- **Jumper Bar Kit 2 Ckt. to 1 Ckt. RXBJ-A21** is used to convert single phase multiple two circuit units to a single supply circuit. Kit includes cover and screw for line side terminals.
- **Note:** No jumper bar kit is available to convert three phase multiple two circuit units to a single supply circuit.

### • Auxiliary Horizontal Overflow Pan Accessory RXBM-

Nominal Cooling Capacity-Tons	Auxiliary Horizontal Overflow Pan Accessory Model Number
1 <sup>1</sup> / <sub>2</sub> - 3	RXBM-AC48
3 <sup>1</sup> / <sub>2</sub> - 5	RXBM-AC61

### • External Filter Rack RXHF-B17, B21, B24

Model Cabinet Size	Filter Size In. [mm]	Part Number*	A	B
21	20 x 20 [508 x 508]	RXHF-B21	20.40	20.77
24	25 x 20 [635 x 508]	RXHF-B24	25.00	21.04

\*Accommodates 1" filter

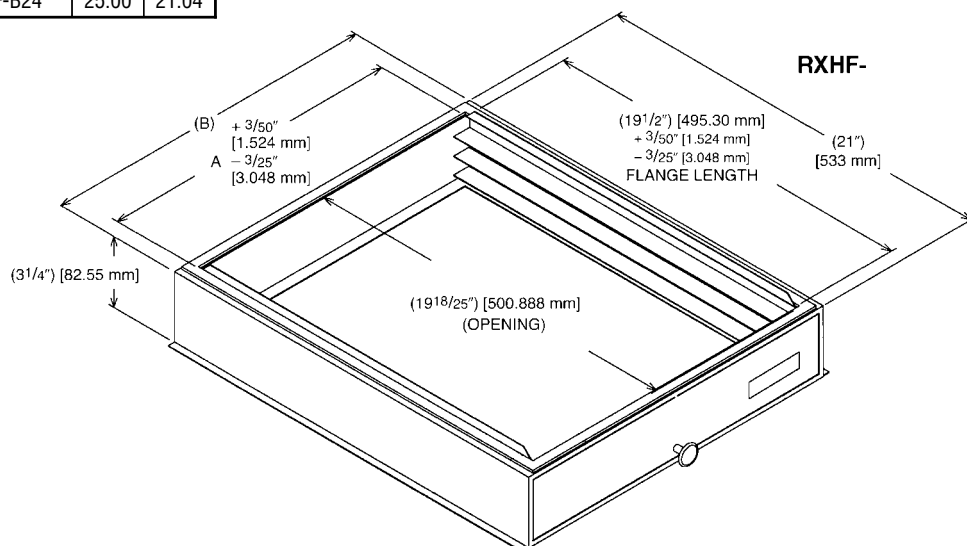
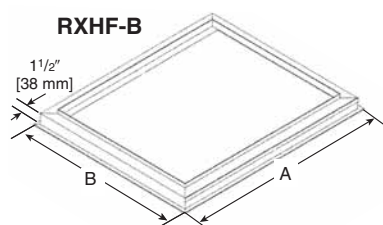

## Grounding

- This product must be sufficiently grounded in accordance with National Electrical Code (C.E.C. in Canada) and any applicable local ordinance.
- A grounding lug is provided.

### • Auxiliary Electric Heater Kits RXBH-

Heater Kits include circuit breakers which meet UL and cUL requirements for service disconnect. See the Electric Heat Electrical Data in this specification sheet for specific Heater Kit Model numbers.

### • External Filter Base RXHF-

Model Cabinet Size	Filter Size In. [mm]	Part Number*	A	B
21	20 x 20 [508 x 508]	RXHF-21	19.20	21.0
24	25 x 20 [635 x 508]	RXHF-24	22.70	25.5

\*Accommodates 1" or 2" filter

[ ] Designates Metric Conversions

**GENERAL TERMS OF LIMITED WARRANTY\***

Ruud will furnish a replacement for any part of this product which fails in normal use and service within the applicable periods stated, in accordance with the terms of the limited warranty.

Parts.....Ten (10) Years

**\*For complete details of the Limited and Conditional Warranties, including applicable terms and conditions, contact your local contractor or the Manufacturer for a copy of the product warranty certificate.**



*In keeping with its policy of continuous progress and product improvement, Ruud reserves the right to make changes without notice.*

Ruud Heating, Cooling & Water Heating • P.O. Box 17010  
Fort Smith, Arkansas 72917 • [www.ruud.com](http://www.ruud.com)

Ruud Canada • 125 Edgeware Road, Unit 1  
Brampton, Ontario • L6Y 0P5

**RELY ON RUUD.™**