

GAS FURNACES



Visit www.Rheem.com/taxcredit for complete details.

Rheem
Prestige[®]
S E R I E S

90 PLUS MODULATING DOWNFLOW GAS FURNACES WITH *CONTOUR COMFORT CONTROL*[®]

RGGD- SERIES

Models with Input Rates
from 60,000 to 120,000 BTU/HR
[17.58 to 35.16 kW]
(U.S. & Canadian Models)

The Rheem *Prestige Series*[™] 90 Plus High Efficiency line of downflow gas furnaces are designed for utility rooms, closets, or alcoves, attics or crawl spaces.

The design is certified by CSA.

Features

- Heat exchanger is constructed of all stainless steel for maximum corrosion resistance and thermal fatigue reliability.
- Modulating Function: when used with a modulating thermostat, modulation rate between 40% and 100% of total capacity.
- Two-stage Function: when used with a two-stage thermostat, furnace operates at 40% on first stage, and stages up to 65%, then 100% for second stage.
- Multistage Function: when used with a single-stage thermostat, furnace functions as a three stage furnace operating at 40%, 65% and 100% of total capacity.
- Reduced firing rates, electrically efficient ECM2+ motor, and solid doors provide the ultimate in quiet operation.
- Low speed constant fan.
- Constant temperature rise for superior comfort.
- Seven segment LED for system diagnostics.
- Diagnostic history for troubleshooting.
- Two-speed induced draft motor.
- Direct spark ignition with remote sense.
- Top electrical connections, left or right gas and condensate drainage connections on downflow models.
- Optional indoor or outdoor combustion air.
- All models comply with Department of Energy test procedures for 2% or less electrical efficiency ratings.

A variety of cooling coils and plenums designed to use with the Rheem *Prestige Series*[™] 90 Plus gas furnaces are available as optional accessories.

†A.F.U.E. (Annual Fuel Utilization Efficiency) calculated in accordance with Department of Energy test procedures.

Modulating Furnace Thermostat



RHC-TST412MDMS





PRESTIGE SERIES™ 90 PLUS HIGH EFFICIENCY MODULATING DOWNFLOW GAS FURNACE

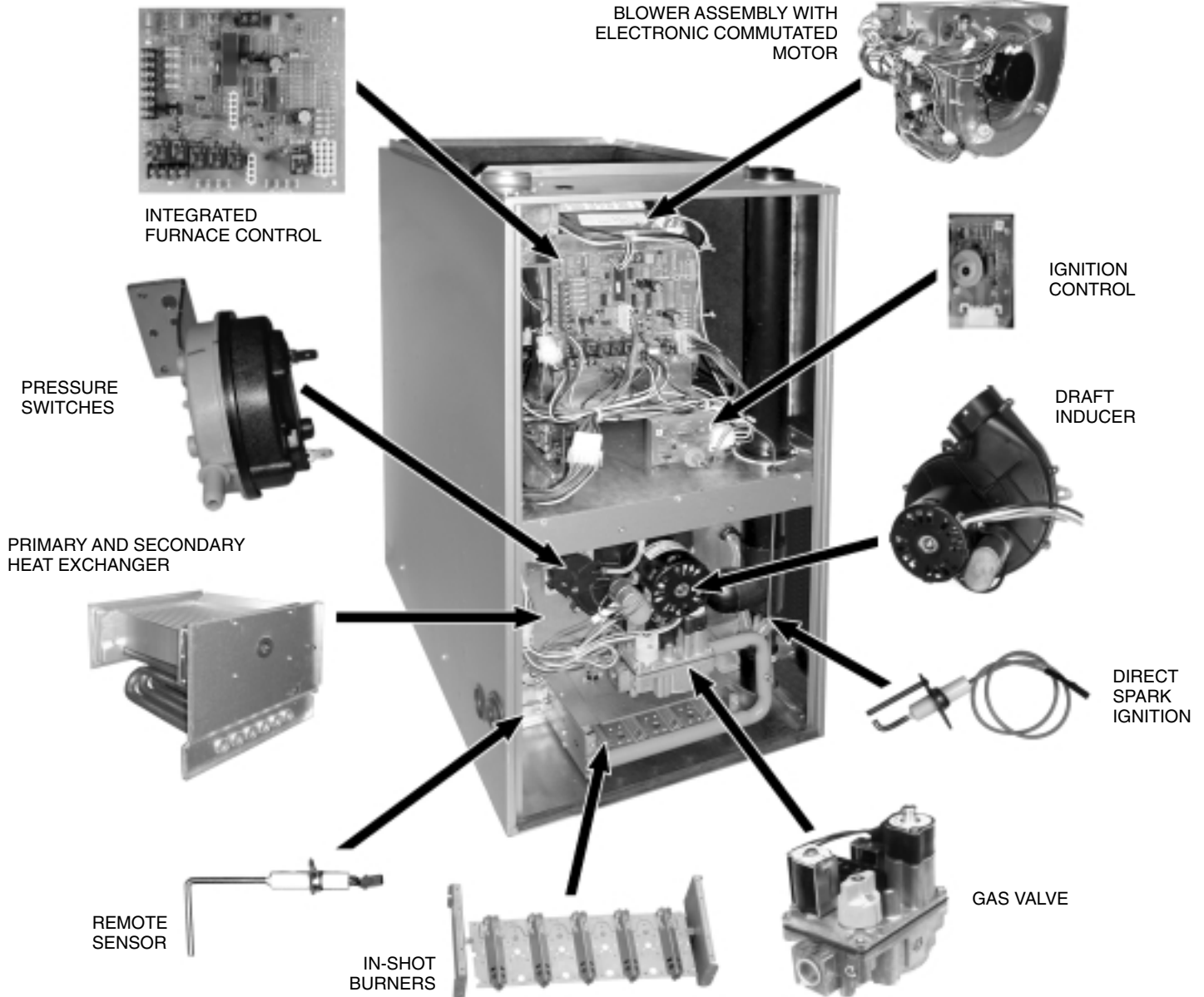

STANDARD EQUIPMENT

Completely assembled and wired; heat exchanger; primary: 409 and aluminized 409 stainless steel, secondary: 29-4C stainless steel; induced draft; pressure switches; redundant modulating main gas control; blower compartment door safety switch; solid state time on/off blower control; limit controls; manual shut-off valve; 100% safety lock out; cool fan off delay; one hour automatic retry; power and self-test diagnostics; flame sense current diagnostics; electronic air cleaner connections; humidifier connections; humidifier on/off delay, dehumidification connection; low speed continuous fan option; transformer; direct drive, ECM variable speed blower motor. (Please note: a thermostat is not included as standard equipment. See "Accessories").

OPTIONAL EQUIPMENT

NOTE: Furnace is not listed for use with fuels other than natural or L.P. (propane) gas.

All models can be converted by a qualified distributor or local service dealer to use L.P. (propane) gas without changing burners. Factory approved kits must be used to convert from natural to L.P. (propane) gas and may be ordered as optional accessories from a parts distributor.

For L.P. (propane) operation, refer to Conversion Kit Index Form. Fossil Fuel Kits for use with heat pumps.

WARNING
THIS FURNACE IS NOT APPROVED
OR RECOMMENDED
FOR USE IN MOBILE HOMES

BEFORE PURCHASING THIS APPLIANCE, READ IMPORTANT ENERGY COST AND EFFICIENCY INFORMATION AVAILABLE FROM YOUR RETAILER.

PHYSICAL DATA AND SPECIFICATIONS—DOWNFLOW MODELS

U.S. and Canadian Models

MODEL NUMBERS	RGGD-06EMCK	RGGD-07EMCK	RGGD-09EZCM	RGGD-10EZCM	RGGD-12ERCM
INPUT-MAXIMUM (BTU/HR) [kW]	60,000 [17.58]	75,000 [21.98]	90,000 [26.38]	105,000 [30.77]	120,000 [35.17]
HEATING CAPACITY-MAXIMUM [kW]	54,720 [16.03]	69,000 [20.22]	83,160 [24.37]	95,865 [28.09]	110,880 [32.49]
INPUT-MINIMUM (BTU/HR) [kW]	24,000 [7.03]	30,000 [8.79]	36,000 [10.55]	42,000 [12.31]	48,000 [14.07]
HEATING CAPACITY-MINIMUM [kW]	21,888 [6.41]	27,600 [8.09]	33,264 [9.75]	38,346 [11.24]	44,352 [12.99]
HEATING EXT. STATIC PRESSURE [kPa]	0.12 [.029]	0.12 [.029]	0.15 [.037]	0.20 [.049]	0.20 [.049]
BLOWER (D X W IN.) [mm]	11 x 7 [279 x 178]	11 x 7 [279 x 178]	12 x 11 [305 x 279]	12 x 11 [305 x 279]	11 x 10 [279 x 254]
ECM MOTOR HP [W]	1/2 [373]	1/2 [373]	1 [746]	1 [746]	1 [746]
UNIT AMPS	8.7	8.7	12.0	12.0	12.0
MAXIMUM OVERCURRENT PROTECTION	15	15	15	15	15
HEATING CFM-MAXIMUM [L/s]	795 [375]	995 [470]	1195 [564]	1395 [658]	1595 [753]
HEATING CFM-MINIMUM [L/s]	320 [151]	430 [203]	515 [243]	600 [283]	685 [323]
COOLING CFM-RANGE [L/s]	600-1200 [283-566]	600-1200 [283-566]	1200-2000 [566-944]	1200-2000 [566-944]	1200-2000 [566-944]
MAXIMUM EXT. STATIC PRESSURE [kPa]	0.80 [0.20]	0.80 [0.20]	0.80 [0.20]	0.80 [0.20]	0.80 [0.20]
TEMPERATURE RISE RANGE °F [°C]	40-70 [22.2-38.9]	40-70 [22.2-38.9]	40-70 [22.2-38.9]	40-70 [22.2-38.9]	40-70 [22.2-38.9]
MAX OUTLET AIR TEMPERATURE °F [°C]	180 [82.2]	180 [82.2]	180 [82.2]	190 [87.8]	195 [90.6]
RETURN AIR CABINETS-RXGR-	C17B	C17B	C21B	C21B	C24B
FILTER SIZE (IN.) [mm] BOTTOM	15 ³ / ₄ x 25 [400 x 635]	15 ³ / ₄ x 25 [400 x 635]	19 ¹ / ₄ x 25 [489 x 635]	19 ¹ / ₄ x 25 [489 x 635]	22 ³ / ₄ x 25 [578 x 635]
FILTER SIZE (IN.) [mm] SIDE	15 ³ / ₄ x 25 [400 x 635]	15 ³ / ₄ x 25 [400 x 635]	15 ³ / ₄ x 25 [400 x 635]	15 ³ / ₄ x 25 [400 x 635]	15 ³ / ₄ x 25 [400 x 635]
APPROX. SHIPPING WEIGHT (LBS.) [kg]	127 [57.6]	133 [60.3]	158 [71.7]	162 [73.5]	170 [77.1]
AFUE	90.3%	90.3%	92.3%	91%	92.2%

MODEL IDENTIFICATION

R	G	G	D	—	07E	M	C	K	S
Rheem	Gas Furnace	Downflow Modulating Prestige Series™ 90 Plus Gas Furnace	Design Series		Heating Input Designation	Blower Size	Variations	Heat/Cool Designation	Fuel Code
					Electric Ignition	M = 11 x 7 [279 x 178 mm]	C = Single/Multi Zone	K = 600-1200 CFM [283-566 L/s]	S = U.S. or Canadian Natural Gas
					Electric Ignition-NOx Models	R = 11 x 10 [279 x 254 mm]		M = 1200-2000 CFM [566-944 L/s]	
					Input BTU/HR	Z = 12 x 11 [305 x 279 mm]			
					06E 06N 60,000 [17.6 kW]				
					07E 07N 75,000 [22.0 kW]				
					09E 09N 90,000 [26.4 kW]				
					10E 10N 105,000 [30.7 kW]				
					12E 12N 120,000 [35.2 kW]				
									Option 278
									278 = Factory Supplied High Altitude Conversion Kit

[] Designates Metric Conversions

DOWNFLOW MODELS

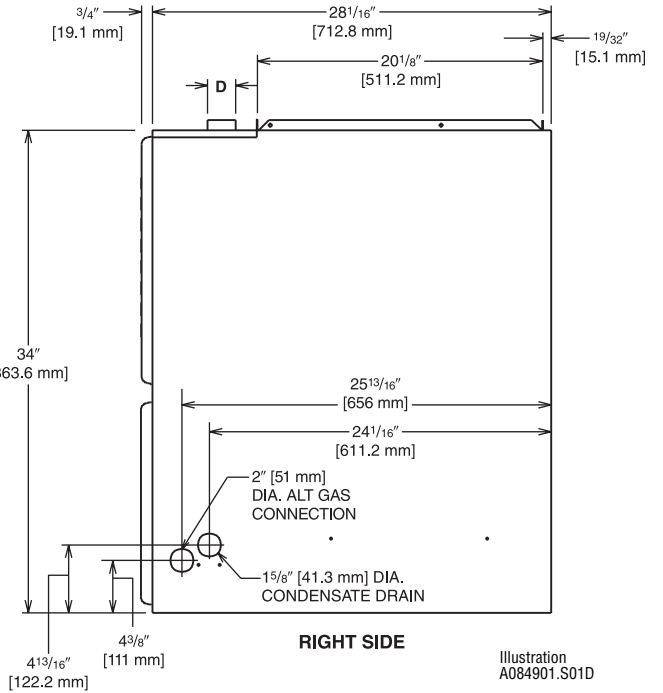
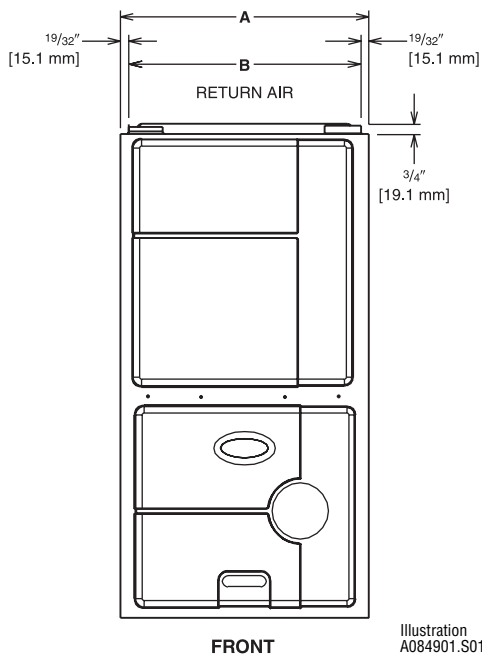
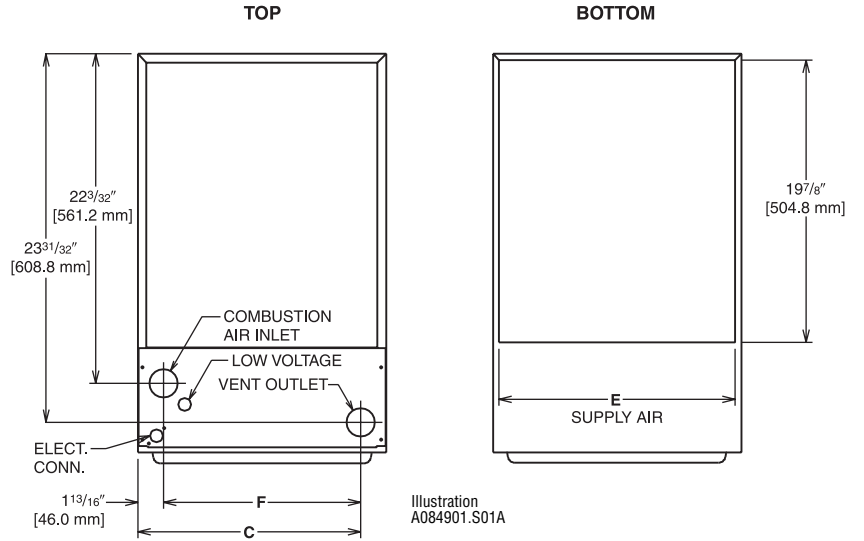
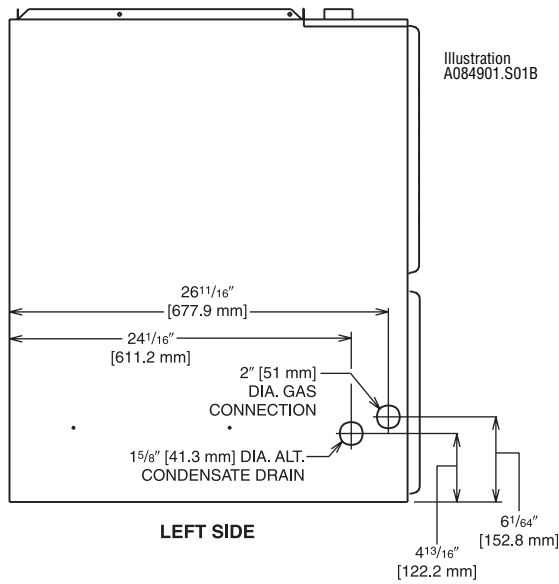

MODEL RGGD-	A	B	C	D	E	F	LEFT SIDE	MINIMUM CLEARANCE (IN.) [mm]				
								RIGHT SIDE	BACK	TOP	FRONT	VENT
06	17 ¹ / ₂ [445]	16 ¹¹ / ₃₂ [415]	15 ⁵ / ₈ [397]	2 [51]	16 ⁵ / ₈ [422]	13 ⁷ / ₈ [352]	0	0	0	1 [25]	2 [51]	0
07	17 ¹ / ₂ [445]	16 ¹¹ / ₃₂ [415]	15 ⁵ / ₈ [397]	2 [51]	16 ⁵ / ₈ [422]	13 ⁷ / ₈ [352]	0	0	0	1 [25]	2 [51]	0
09	21 [533]	19 ²⁷ / ₃₂ [504]	19 ³ / ₁₆ [487]	2 [51]	20 ¹ / ₈ [511]	17 ³ / ₈ [441]	0	0	0	1 [25]	2 [51]	0
10	21 [533]	19 ²⁷ / ₃₂ [504]	19 ³ / ₁₆ [487]	2 [51]	20 ¹ / ₈ [511]	17 ³ / ₈ [441]	0	0	0	1 [25]	2 [51]	0
12	24 ¹ / ₂ [622]	23 ¹¹ / ₃₂ [593]	22 ⁵ / ₈ [575]	2 [51]	23 ⁵ / ₈ [600]	20 ⁷ / ₈ [530]	0	0	0	1 [25]	2 [51]	0

[] Designates Metric Conversions

BLOWER PERFORMANCE DATA—RGGD MODELS

MODEL RGGD-	BLOWER SIZE (D x W) IN. [mm]	ICM MOTOR H.P. [W]	BLOWER SPEED	CFM [L/s] AIR DELIVERY EXTERNAL STATIC PRESSURE INCHES WATER COLUMN [kPa]
				0.1 [.02]-0.8 [.20]
06	11 x 7 [279 x 178]	1/2 [373]	HIGH	1200 [566]
			MED-HI	1000 [472]
			MED	800 [378]
			LOW	600 [283]
07	11 x 7 [279 x 178]	1/2 [373]	HIGH	1200 [566]
			MED-HI	1000 [472]
			MED	800 [378]
			LOW	600 [283]
09	12 x 11 [305 x 279]	1 [746]	HIGH	2000 [944]
			MED-HI	1600 [755]
			MED	1400 [661]
			LOW	1200 [566]
10	12 x 11 [305 x 279]	1 [746]	HIGH	2000 [944]
			MED-HI	1600 [755]
			MED	1400 [661]
			LOW	1200 [566]
12	11 x 10 [279 x 254]	1 [746]	HIGH	2000 [944]
			MED-HI	1600 [755]
			MED	1400 [661]
			LOW	1200 [566]

[] Designates Metric Conversions

GENERAL TERMS OF LIMITED WARRANTY*

Rheem will furnish a replacement for any part of this product which fails in normal use and service within the applicable period stated, in accordance with the terms of the limited warranty.

Primary and Secondary Heat ExchangerLimited Lifetime

Conditional Unit Replacement Warranty
(Registration Required)Limited Lifetime

Parts WarrantyTen (10) Years

***For Complete Details of the Limited Warranty, Including Applicable Terms and Conditions, See Your Local Installer or Contact the Manufacturer for a Copy of the Product Warranty Card.**

ACCESSORIES—DOWNFLOW

VENT TERMINATION KITS CONCENTRIC: HORIZONTAL/ VERTICAL =

RXGY-E03A (US & Canadian Installations)

HORIZONTAL TWO PIPE: RXGY-D02, RXGY-D03, RXGY-D04
(US Installations)

RXGY-D02A, RXGY-D03A, RXGY-D04A (Canadian Installations)

RXGY-G02 (US Only)

NEUTRALIZER KIT: RXGY-A01

COMBUSTIBLE FLOOR BASE: RXGC-B17
RXGC-B21
RXGC-B24

EXTERNAL FILTER RACK: RXGF-CC

FILTER RACK FILTER SIZES* INCHES [mm]	
MODEL RGGD-	RXGF-CC
06	(2) 12 x 20 [305 x 508]
07	(2) 12 x 20 [305 x 508]
09	(2) 12 x 20 [305 x 508]
10	(2) 12 x 20 [305 x 508]
12	(2) 14 x 20 [305 x 508]

*Filter racks are shipped without filters.
Filters shipped with furnace may be used or a suitable 1" [25.4 mm] filter.

FOSSIL FUEL KIT: RXPF-F02

PLENUM DATA FOR "A" COILS

Plenum adapters are required in some instances for use on downflow applications when plenum and furnace size do not match.

FURNACE WIDTH IN. [mm]	PLENUM WIDTH IN. [mm]	PLENUM ADAPTER UPFLOW	COIL PLENUM
17½ [445]	16¼ [413]	RXAA-C186	RXAL-B16BU
17½ [445]	20¼ [514]	RXAA-C173	RXAL-B20BU
17½ [445]	21⅝ [549]	RXAA-C187	RXAL-B21BU
17½ [445]	25¼ [641]	RXAA-C174	RXAL-B25BU
21 [533]	25¼ [641]	RXAA-C175	RXAL-B25BU
21 [533]	22¼ [565]	RXAA-C176	RXAL-B22BU
21 [533]	21⅝ [549]	RXAA-C188	RXAL-B21BU
24½ [622]	25¼ [641]	RXAA-C177	RXAL-B25BU
24½ [622]	21⅝ [549]	RXAA-C187	RXAL-B21BU

Note: See Form Number C11-206 for MultiFlex® coil data.

LP KIT: (Available through PROSTOCK®)
U.S./Canadian = RXGJ-FP07

THERMOSTATS

RECOMMENDED MODULATING FURNACE THERMOSTAT



RHC-TST412MDMS

- 7 Day 5/1/1 Programmable Modulating/Two Cool Hardwired
- Works in Modulating Furnace and Modulating Furnace Dual Fuel applications (requires optional external sensor)
- Bright, 12 sq. inch touchscreen display
- Keypad lockout option
- Hardwired
- Easy, menu-driven programming
- Audio prompting to ensure program change confirmation
- Intuitive red/blue temperature keys
- Large, easy-to-see characters
- Available only through professional contractors

*PROGRAMMABLE THERMOSTAT ACCESSORIES:

Adapter Plate = F61-2600
Remote F1451328 and F1451378 Sensor

*Available through PROSTOCK®.

[] Designates Metric Conversions

ACCESSORIES—DOWNFLOW (con't.)

FOR HIGH ALTITUDES:

RGGD HIGH ALTITUDE FIELD CONVERSION KITS:

MODEL	INPUT (KBTU)	KIT NO.
-GGD-06	60,000	None Needed
-GGD-07	75,000	RXGY-F23 (8000 ft. only)
-GGD-09*	90,000	RXGY-F24
-GGD-10*	105,000	RXGY-F25
-GGD-12*	120,000	RXGY-F26

*5000 ft. & above only (except where noted).

OPTION CODE FOR HIGH ALTITUDE: U.S. & CANADA – 278

NOTE: High altitude kits and options do **NOT** include additional burner orifices. If a burner orifice change is necessary, they must be ordered through PROSTOCK®. See Installation Instructions for more information.

Option – 278 furnaces are shipped with #51 DMS orifices installed. This is one drill size smaller than standard furnaces to account for expected average elevations and heating values typically seen in these areas.

CAUTION: Always follow National Fuel Gas Code (NFGC) guidelines when converting furnaces for high altitudes.

For all installations above 2000 ft. (including all option – 278 models), the burner orifice size must be recalculated and verified. A burner orifice change may still be required. See Installation Instructions for more information.

Manifold gas pressure reduction methods may **NOT** be used on these models. The only method permitted on modulating furnace models is to recalculate the burner orifice size. See Installation Instructions for more information.

ALTERNATE (LEFT SIDE) CONDENSATE DRAIN KIT:

RXGY-H01 (All Models)

[] Designates Metric Conversions

Before proceeding with installation, refer to installation instructions packaged with each model, as well as complying with all Federal, State, Provincial, and Local codes, regulations, and practices.

**Rheem Heating,
Cooling and
Water Heating**

P.O. Box 17010, Fort Smith, AR 72917



"In keeping with its policy of continuous progress and product improvement, Rheem reserves the right to make changes without notice."