



PACKAGE HEAT PUMPS

FORM NO. P66-767

Featuring Earth-Friendly R-410A Refrigerant



RQNL-B HIGH EFFICIENCY 13-SEER SERIES NOMINAL SIZES 2-4 TONS [7.03-14.07 kW]

RQPL-B HIGH EFFICIENCY 14-SEER SERIES NOMINAL SIZES 2-4 TONS [7.03-14.07 kW]



Manufactured by





Unit Features & Benefits	3-4
Model Identification Options.....	5-6
General Data	
RQNL-B Series	7-8
RQPL-B Series	9-10
General Data Notes	11
Performance Data	
RQNL-B Series	12-16
RQPL-B Series	17-21
Airflow Performance	
RQNL-B Series	22-23
RQPL-B Series	24-25
Electrical Data	
RQNL-B Series	26
RQPL-B Series	26
Electric Heater Kits	27-29
Dimensional Data	30-31
Typical Installations	32
Accessories	33-40
Typical Wiring.....	41-44
Limited Warranty	46

These quality features are included in the WeatherKing Outdoor Package Heat Pumps

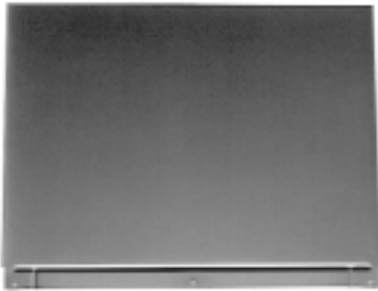

5

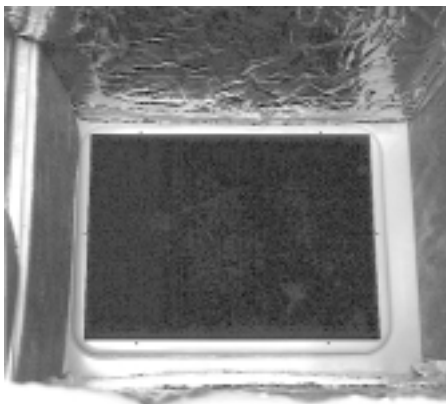
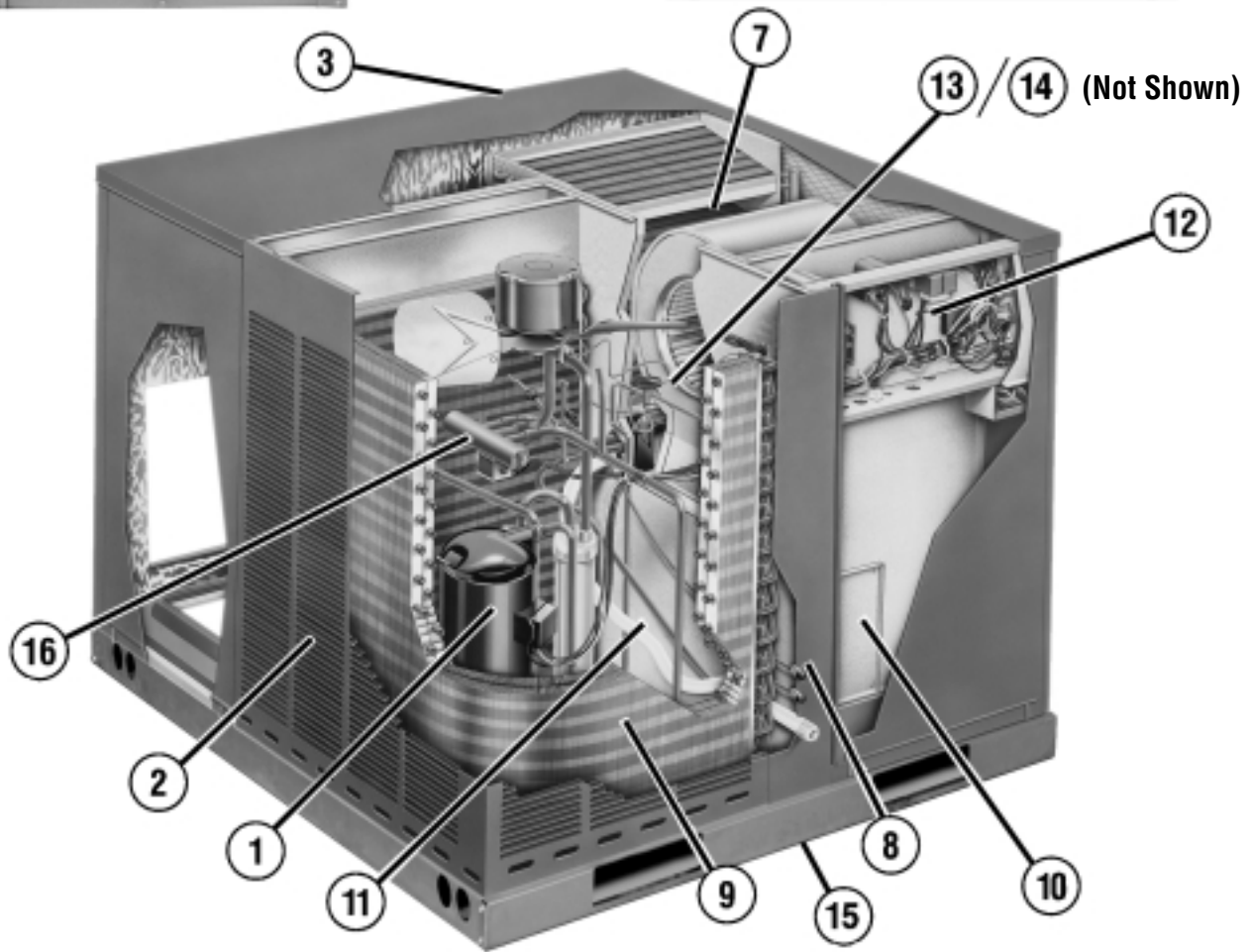
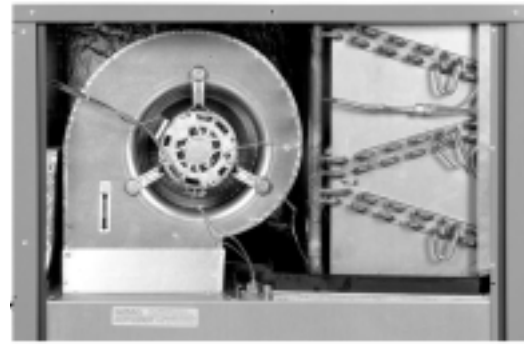

4

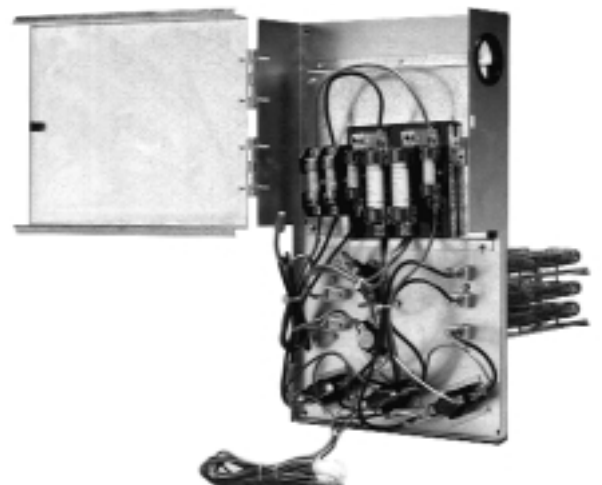



Features Below Correspond to Photos on Page 3

1. All models feature Copeland® Scroll® compressors for maximum efficiency and quiet operation. This unit contains a special scroll compressor that is designed specifically to operate with R-410A Refrigerants and polyolester (POE) oils. The compressor is hermetically sealed and incorporates internal high temperature motor overload protection and durable insulation on the motor windings. It is externally mounted on rubber grommets to reduce vibration and noise.
2. Louvered condenser compartment for protecting the coil against yard hazards and/or weather extremes.
3. One-piece top with a deep flange to help keep water out of the unit.
4. Supply and return air openings feature a one-inch tall flange to prevent water migration into the ductwork.
5. Access panels have “weep holes” and channels to further help manage water run-off.
6. Side and down discharge options available on all models. (Shipped Downflow Standard).
7. Easily accessible blower section complete with slide-out blower.
8. Refrigerant connections are conveniently located for easy service diagnostics.
9. Condenser and evaporator coils feature enhanced fins for better heat transfer and rifled copper tubing for greater efficiency.
10. Supplemental electric heat strips up to 15 kW are available (field or factory installed) for periods of extreme cold temperatures. Single point wiring makes installation even easier.
11. All units feature an internal trap on the condensate line eliminating the need for installing an on-site external trap.
12. Easily accessible control box. Package heat pump utilizes demand defrost control which monitors the outdoor ambient temperature, outdoor coil temperature, and compressor run-time to determine when a defrost cycle is required.
13. Thermal Expansion Valve standard on all models for superior superheat control, reliability, and energy efficiency at all operating conditions.
14. Filter Drier Standard on all models (not shown).
15. Rugged Baserail for improved installation and handling.
16. Reversing valve directs flow of refrigerant and reverses the refrigerant flow when heating is required.



MODEL IDENTIFICATION—RQNL-B/RQPL-B SERIES



R Q N L — B024 J K 000 XXX

Factory Installed Options
(See Next Page)

Heating Capacity (Factory Installed)
000 = No Resistance Heat
005 = 05 KW Resistance Heat (018-030)
010 = 10 KW Resistance Heat (024-048)
015 = 15 KW Resistance Heat (036-048)

Drive Package
K = Direct Drive

Electrical Designation
J = 208-230V—1PH—60 Hz
C = 208-230V—3PH—60 Hz

Cooling Capacity (BTUH) [kW]
024 = 24,000 [7.03]
030 = 30,000 [8.79]
036 = 36,000 [10.55]
042 = 42,000 [12.31]
048 = 48,000 [14.07]

Design Series
L = R-410A

Efficiency Designation
N = 13 SEER High Efficiency
P = 14 SEER High Efficiency

Product Classification
Q = Package Heat Pump

Tradebrand
R = WeatherKing

[] Designates Metric Conversions



Instructions for Factory Installed Option(s) Selection

Note: Two characters following the model number will be utilized to designate a factory-installed option or combination of options. If no factory option(s) is required, nothing follows the model number.

Step 1. After a basic rooftop model is selected, choose a *two-character* option code from the FACTORY INSTALLED OPTION SELECTION TABLE.

FACTORY INSTALLED OPTION CODES

Option Code	Side Flow
AA	No Option
AKA	x

Example: RQNL-B036JK000**XX** (where **XX** is factory installed option)

Example: No Options

RQNL-B036JK000

Example: Options with Sideflow

RQNL-B036JK000AKA

Note: Factory installed economizer is not available on these models.



NOMINAL SIZES 2-4 TONS [7.03-14.07 kW]

Model RQNL-B Series	B024JK	B030JK	B036CK	B036JK
Cooling Performance¹				CONTINUED →
Gross Cooling Capacity Btu [kW]	24,400 [7.15]	29,000 [8.5]	36,200 [10.61]	36,200 [10.61]
EER/SEER ²	11/13	11/13	11/13	11/13
Nominal CFM/ARI Rated CFM [L/s]	800/800 [378/378]	1000/1000 [472/472]	1200/1250 [566/590]	1200/1250 [566/590]
ARI Net Cooling Capacity Btu [kW]	23,600 [6.91]	27,800 [8.15]	35,000 [10.26]	35,000 [10.26]
Net Sensible Capacity Btu [kW]	17,600 [5.16]	20,800 [6.09]	26,000 [7.62]	26,000 [7.62]
Net Latent Capacity Btu [kW]	6,000 [1.76]	7,000 [2.05]	9,000 [2.64]	9,000 [2.64]
Net System Power kW	2.15	2.53	3.18	3.18
Heating Performance (Heat Pumps)⁴				
Heating Input Btu [kW] Rating	23,600 [6.91]	28,200 [8.26]	34,000 [9.96]	34,000 [9.96]
System Power KW/COP	2.02/3.4	2.45/3.4	2.86/3.5	2.86/3.5
Low Temp. Btuh [kW] Rating	13,000 [3.81]	16,000 [4.69]	19,500 [5.71]	19,500 [5.71]
System Power KW/COP	1.9/2	2.26/2.1	2.61/2.2	2.61/2.2
HSPF (Btu/Watts-hr)	7.7	7.7	7.7	7.7
Compressor				
No./Type	1/Copeland Scroll	1/Copeland Scroll	1/Copeland Scroll	1/Copeland Scroll
Outdoor Sound Rating (dB)³				
	76	76	76	76
Outdoor Coil—Fin Type				
Tube Type	Louvered	Louvered	Louvered	Louvered
Tube Size in. [mm] OD	Rifled	Rifled	Rifled	Rifled
Tube Size in. [mm] OD	0.375 [9.5]	0.375 [9.5]	0.375 [9.5]	0.375 [9.5]
Face Area sq. ft. [sq. m]	14.51 [1.35]	16.32 [1.52]	11.2 [1.04]	11.2 [1.04]
Rows / FPI [FPcm]	1 / 22 [9]	1 / 22 [9]	2 / 22 [9]	2 / 22 [9]
Refrigerant Control	TX Valves	TX Valves	TX Valves	TX Valves
Indoor Coil—Fin Type				
Tube Type	Louvered	Louvered	Louvered	Louvered
Tube Type	Rifled	Rifled	Rifled	Rifled
Tube Size in. [mm]	0.375 [9.5]	0.375 [9.5]	0.375 [9.5]	0.375 [9.5]
Face Area sq. ft. [sq. m]	5.54 [0.51]	7.39 [0.69]	7.39 [0.69]	7.39 [0.69]
Rows / FPI [FPcm]	2 / 15 [6]	2 / 15 [6]	2 / 15 [6]	2 / 15 [6]
Refrigerant Control	TX Valves	TX Valves	TX Valves	TX Valves
Drain Connection No./Size in. [mm]	1/1 [25.4]	1/1 [25.4]	1/1 [25.4]	1/1 [25.4]
Outdoor Fan—Type				
Propeller	Propeller	Propeller	Propeller	Propeller
No. Used/Diameter in. [mm]	1/22 [558.8]	1/22 [558.8]	1/22 [558.8]	1/22 [558.8]
Drive Type/No. Speeds	Direct/1	Direct/1	Direct/1	Direct/1
CFM [L/s]	2700 [1274]	2700 [1274]	2700 [1274]	2700 [1274]
No. Motors/HP	1 at 1/5 HP	1 at 1/5 HP	1 at 1/5 HP	1 at 1/5 HP
Motor RPM	1075	1075	1075	1075
Indoor Fan—Type				
FC Centrifugal	FC Centrifugal	FC Centrifugal	FC Centrifugal	FC Centrifugal
No. Used/Diameter in. [mm]	1/9x7 [228.6x177.8]	1/10x9 [254x228.6]	1/10x9 [254x228.6]	1/10x9 [254x228.6]
Drive Type/No. Speeds	Direct/2	Direct/3	Direct/1	Direct/1
No. Motors	1	1	1	1
Motor HP	1/4	1/2	1/3	1/3
Motor RPM	1075	1075	1075	1075
Motor Frame Size	48	48	48	48
Filter—Type				
Field Supplied	Field Supplied	Field Supplied	Field Supplied	Field Supplied
Furnished	No	No	No	No
(No.) Size Recommended in. [mm]	(1)1x20x20 [25x508x508]	(1)1x24x24 [25x610x610]	(1)1x24x24 [25x610x610]	(1)1x24x24 [25x610x610]
Refrigerant Charge Oz. [g]				
	98 [2778]	108 [3062]	146 [4139]	146 [4139]
Weights				
Net Weight lbs. [kg]	391 [177]	444 [201]	471 [214]	468 [212]
Ship Weight lbs. [kg]	401 [182]	455 [206]	482 [219]	479 [217]

See Page 11 for Notes.

[] Designates Metric Conversions

NOMINAL SIZES 2-4 TONS [7.03-14.07 kW]

Model RQNL-B Series	B042CK	B042JK	B048CK	B048JK
Cooling Performance¹				
Gross Cooling Capacity Btu [kW]	43,500 [12.75]	43,500 [12.75]	49,000 [14.36]	49,000 [14.36]
EER/SEER ²	11/13	11/13	11/13	11/13
Nominal CFM/ARI Rated CFM [L/s]	1400/1400 [661/661]	1400/1400 [661/661]	1600/1600 [755/755]	1600/1600 [755/755]
ARI Net Cooling Capacity Btu [kW]	42,500 [12.45]	42,500 [12.45]	47,500 [13.92]	47,500 [13.92]
Net Sensible Capacity Btu [kW]	31,500 [9.23]	31,500 [9.23]	36,000 [10.55]	36,000 [10.55]
Net Latent Capacity Btu [kW]	11,000 [3.22]	11,000 [3.22]	11,500 [3.37]	11,500 [3.37]
Net System Power kW	3.86	3.86	4.31	4.31
Heating Performance (Heat Pumps)⁴				
Heating Input Btu [kW] Rating	41,500 [12.16]	41,500 [12.16]	46,000 [13.48]	46,000 [13.48]
System Power KW/COP	3.65/3.4	3.65/3.4	3.89/3.4	3.89/3.4
Low Temp. Btuh [kW] Rating	24,200 [7.09]	24,200 [7.09]	26,600 [7.79]	26,600 [7.79]
System Power KW/COP	3.43/2.08	3.43/2.08	3.57/2.2	3.57/2.2
HSPF (Btu/Watts-hr)	7.7	7.7	7.7	7.7
Compressor				
No./Type	1/Copeland Scroll	1/Copeland Scroll	1/Copeland Scroll	1/Copeland Scroll
Outdoor Sound Rating (dB)³				
	76	76	78	78
Outdoor Coil—Fin Type				
Tube Type	Louvered	Louvered	Louvered	Louvered
Tube Type	Rifled	Rifled	Rifled	Rifled
Tube Size in. [mm] OD	0.375 [9.5]	0.375 [9.5]	0.375 [9.5]	0.375 [9.5]
Face Area sq. ft. [sq. m]	16.32 [1.52]	16.32 [1.52]	16.32 [1.52]	16.32 [1.52]
Rows / FPI [FPcm]	2 / 22 [9]	2 / 22 [9]	2 / 22 [9]	2 / 22 [9]
Refrigerant Control	TX Valves	TX Valves	TX Valves	TX Valves
Indoor Coil—Fin Type				
Tube Type	Louvered	Louvered	Louvered	Louvered
Tube Type	Rifled	Rifled	Rifled	Rifled
Tube Size in. [mm]	0.375 [9.5]	0.375 [9.5]	0.375 [9.5]	0.375 [9.5]
Face Area sq. ft. [sq. m]	7.39 [0.69]	7.39 [0.69]	7.39 [0.69]	7.39 [0.69]
Rows / FPI [FPcm]	2 / 15 [6]	2 / 15 [6]	2 / 15 [6]	2 / 15 [6]
Refrigerant Control	TX Valves	TX Valves	TX Valves	TX Valves
Drain Connection No./Size in. [mm]	1/1 [25.4]	1/1 [25.4]	1/1 [25.4]	1/1 [25.4]
Outdoor Fan—Type				
Propeller	Propeller	Propeller	Propeller	Propeller
No. Used/Diameter in. [mm]	1/22 [558.8]	1/22 [558.8]	1/22 [558.8]	1/22 [558.8]
Drive Type/No. Speeds	Direct/1	Direct/1	Direct/1	Direct/1
CFM [L/s]	3300 [1557]	3300 [1557]	3000 [1416]	3000 [1416]
No. Motors/HP	1 at 1/3 HP	1 at 1/3 HP	1 at 1/3 HP	1 at 1/3 HP
Motor RPM	1075	1075	1075	1075
Indoor Fan—Type				
FC Centrifugal	FC Centrifugal	FC Centrifugal	FC Centrifugal	FC Centrifugal
No. Used/Diameter in. [mm]	1/10x9 [254x228.6]	1/10x9 [254x228.6]	1/10x9 [254x228.6]	1/10x9 [254x228.6]
Drive Type/No. Speeds	Direct/2	Direct/2	Direct/2	Direct/2
No. Motors	1	1	1	1
Motor HP	3/4	3/4	3/4	3/4
Motor RPM	1075	1075	1075	1075
Motor Frame Size	48	48	48	48
Filter—Type				
Field Supplied	Field Supplied	Field Supplied	Field Supplied	Field Supplied
Furnished	No	No	No	No
(No.) Size Recommended in. [mm]	(1)1x24x24 [25x610x610]	(1)1x24x24 [25x610x610]	(1)1x24x24 [25x610x610]	(1)1x24x24 [25x610x610]
Refrigerant Charge Oz. [g]				
	176 [4990]	176 [4990]	183 [5188]	183 [5188]
Weights				
Net Weight lbs. [kg]	508 [230]	505 [229]	500 [227]	510 [231]
Ship Weight lbs. [kg]	519 [235]	516 [234]	511 [232]	521 [236]

See Page 11 for Notes.

[] Designates Metric Conversions



NOMINAL SIZES 2-4 TONS [7.03-14.07 kW]

Model RQPL-B Series	B024JK	B030JK	B036CK	B036JK
Cooling Performance¹				CONTINUED →
Gross Cooling Capacity Btu [kW]	25,000 [7.32]	29,800 [8.73]	36,800 [10.78]	36,800 [10.78]
EER/SEER ²	11.8/14	12/14	12/14	12/14
Nominal CFM/ARI Rated CFM [L/s]	800/850 [378/401]	1000/1050 [472/495]	1200/1250 [566/590]	1200/1250 [566/590]
ARI Net Cooling Capacity Btu [kW]	24,400 [7.15]	29,200 [8.56]	36,000 [10.55]	36,000 [10.55]
Net Sensible Capacity Btu [kW]	18,900 [5.54]	23,000 [6.74]	27,000 [7.91]	27,000 [7.91]
Net Latent Capacity Btu [kW]	5,500 [1.61]	6,200 [1.82]	9,000 [2.64]	9,000 [2.64]
Net System Power kW	2.06	2.43	3	3
Heating Performance (Heat Pumps)⁴				
Heating Input Btu [kW] Rating	23,800 [6.97]	27,800 [8.15]	33,200 [9.73]	33,200 [9.73]
System Power KW/COP	1.94/3.5	2.27/3.6	2.73/3.6	2.73/3.6
Low Temp. Btuh [kW] Rating	13,800 [4.04]	15,500 [4.54]	18,000 [5.27]	18,000 [5.27]
System Power KW/COP	1.78/2.2	2.07/2.2	2.5/2.2	2.5/2.2
HSPF (Btu/Watts-hr)	8	8	8	8
Compressor				
No./Type	1/Copeland Scroll	1/Copeland Scroll	1/Copeland Scroll	1/Copeland Scroll
Outdoor Sound Rating (dB)³				
	76	76	76	76
Outdoor Coil—Fin Type				
Tube Type	Louvered	Louvered	Louvered	Louvered
Tube Size in. [mm] OD	Rifled	Rifled	Rifled	Rifled
Tube Size in. [mm] OD	0.375 [9.5]	0.375 [9.5]	0.375 [9.5]	0.375 [9.5]
Face Area sq. ft. [sq. m]	14.51 [1.35]	16.32 [1.52]	11.2 [1.04]	11.2 [1.04]
Rows / FPI [FPcm]	1 / 22 [9]	1 / 22 [9]	2 / 22 [9]	2 / 22 [9]
Refrigerant Control	TX Valves	TX Valves	TX Valves	TX Valves
Indoor Coil—Fin Type				
Tube Type	Louvered	Louvered	Louvered	Louvered
Tube Type	Rifled	Rifled	Rifled	Rifled
Tube Size in. [mm]	0.375 [9.5]	0.375 [9.5]	0.375 [9.5]	0.375 [9.5]
Face Area sq. ft. [sq. m]	5.54 [0.51]	7.39 [0.69]	7.39 [0.69]	7.39 [0.69]
Rows / FPI [FPcm]	2 / 15 [6]	2 / 15 [6]	2 / 15 [6]	2 / 15 [6]
Refrigerant Control	TX Valves	TX Valves	TX Valves	TX Valves
Drain Connection No./Size in. [mm]	1/1 [25.4]	1/1 [25.4]	1/1 [25.4]	1/1 [25.4]
Outdoor Fan—Type				
Propeller	Propeller	Propeller	Propeller	Propeller
No. Used/Diameter in. [mm]	1/22 [558.8]	1/22 [558.8]	1/22 [558.8]	1/22 [558.8]
Drive Type/No. Speeds	Direct/1	Direct/1	Direct/1	Direct/1
CFM [L/s]	2700 [1274]	2700 [1274]	2700 [1274]	2700 [1274]
No. Motors/HP	1 at 1/5 HP	1 at 1/5 HP	1 at 1/5 HP	1 at 1/5 HP
Motor RPM	1075	1075	1075	1075
Indoor Fan—Type				
FC Centrifugal	FC Centrifugal	FC Centrifugal	FC Centrifugal	FC Centrifugal
No. Used/Diameter in. [mm]	1/9x7 [228.6x177.8]	1/10x9 [254x228.6]	1/10x9 [254x228.6]	1/10x9 [254x228.6]
Drive Type/No. Speeds	Direct/2	Direct/3	Direct/3	Direct/3
No. Motors	1	1	1	1
Motor HP	1/3	1/2	1/2	1/2
Motor RPM	1050	1050	1075	1050
Motor Frame Size	48	48	48	48
Filter—Type				
Field Supplied	Field Supplied	Field Supplied	Field Supplied	Field Supplied
Furnished	No	No	No	No
(No.) Size Recommended in. [mm]	(1)1x20x20 [25x508x508]	(1)1x24x24 [25x610x610]	(1)1x24x24 [25x610x610]	(1)1x24x24 [25x610x610]
Refrigerant Charge Oz. [g]				
	98 [2778]	108 [3062]	146 [4139]	146 [4139]
Weights				
Net Weight lbs. [kg]	391 [177]	444 [201]	471 [214]	468 [212]
Ship Weight lbs. [kg]	401 [182]	455 [206]	482 [219]	479 [217]

See Page 11 for Notes.

[] Designates Metric Conversions

NOMINAL SIZES 2-4 TONS [7.03-14.07 kW]

Model RQPL-B Series	B042CK	B042JK	B048CK	B048JK
Cooling Performance¹				
Gross Cooling Capacity Btu [kW]	43,500 [12.75]	43,500 [12.75]	49,000 [14.36]	49,000 [14.36]
EER/SEER ²	11.3/14	11.3/14	11.5/14	11.5/14
Nominal CFM/ARI Rated CFM [L/s]	1400/1400 [661/661]	1400/1400 [661/661]	1600/1600 [755/755]	1600/1600 [755/755]
ARI Net Cooling Capacity Btu [kW]	42,500 [12.45]	42,500 [12.45]	47,500 [13.92]	47,500 [13.92]
Net Sensible Capacity Btu [kW]	31,500 [9.23]	31,500 [9.23]	36,000 [10.55]	36,000 [10.55]
Net Latent Capacity Btu [kW]	11,000 [3.22]	11,000 [3.22]	11,500 [3.37]	11,500 [3.37]
Net System Power kW	3.85	3.85	4.26	4.26
Heating Performance (Heat Pumps)⁴				
Heating Input Btu [kW] Rating	41,500 [12.16]	41,500 [12.16]	46,000 [13.48]	46,000 [13.48]
System Power KW/COP	3.65/3.4	3.65/3.4	3.89/3.45	3.89/3.45
Low Temp. Btuh [kW] Rating	24,200 [7.09]	24,200 [7.09]	26,600 [7.79]	26,600 [7.79]
System Power KW/COP	3.43/2.08	3.43/2.08	3.57/2.2	3.57/2.2
HSPF (Btu/Watts-hr)	8	8	8	8
Compressor				
No./Type	1/Copeland Scroll	1/Copeland Scroll	1/Copeland Scroll	1/Copeland Scroll
Outdoor Sound Rating (dB)³				
	76	76	78	78
Outdoor Coil—Fin Type				
Tube Type	Louvered	Louvered	Louvered	Louvered
Tube Size in. [mm] OD	Rifled	Rifled	Rifled	Rifled
Tube Size in. [mm] OD	0.375 [9.5]	0.375 [9.5]	0.375 [9.5]	0.375 [9.5]
Face Area sq. ft. [sq. m]	16.32 [1.52]	16.32 [1.52]	16.32 [1.52]	16.32 [1.52]
Rows / FPI [FPcm]	2 / 22 [9]	2 / 22 [9]	2 / 22 [9]	2 / 22 [9]
Refrigerant Control	TX Valves	TX Valves	TX Valves	TX Valves
Indoor Coil—Fin Type				
Tube Type	Louvered	Louvered	Louvered	Louvered
Tube Type	Rifled	Rifled	Rifled	Rifled
Tube Size in. [mm]	0.375 [9.5]	0.375 [9.5]	0.375 [9.5]	0.375 [9.5]
Face Area sq. ft. [sq. m]	7.39 [0.69]	7.39 [0.69]	7.39 [0.69]	7.39 [0.69]
Rows / FPI [FPcm]	2 / 15 [6]	2 / 15 [6]	2 / 15 [6]	2 / 15 [6]
Refrigerant Control	TX Valves	TX Valves	TX Valves	TX Valves
Drain Connection No./Size in. [mm]	1/1 [25.4]	1/1 [25.4]	1/1 [25.4]	1/1 [25.4]
Outdoor Fan—Type				
Propeller	Propeller	Propeller	Propeller	Propeller
No. Used/Diameter in. [mm]	1/22 [558.8]	1/22 [558.8]	1/22 [558.8]	1/22 [558.8]
Drive Type/No. Speeds	Direct/1	Direct/1	Direct/1	Direct/1
CFM [L/s]	3300 [1557]	3300 [1557]	3000 [1416]	3000 [1416]
No. Motors/HP	1 at 1/3 HP	1 at 1/3 HP	1 at 1/3 HP	1 at 1/3 HP
Motor RPM	1075	1075	1075	1075
Indoor Fan—Type				
FC Centrifugal	FC Centrifugal	FC Centrifugal	FC Centrifugal	FC Centrifugal
No. Used/Diameter in. [mm]	1/10x9 [254x228.6]	1/10x9 [254x228.6]	1/10x9 [254x228.6]	1/10x9 [254x228.6]
Drive Type/No. Speeds	Direct/2	Direct/2	Direct/2	Direct/2
No. Motors	1	1	1	1
Motor HP	3/4	3/4	3/4	3/4
Motor RPM	1075	1075	1075	1075
Motor Frame Size	48	48	48	48
Filter—Type				
Field Supplied	Field Supplied	Field Supplied	Field Supplied	Field Supplied
Furnished	No	No	No	No
(No.) Size Recommended in. [mm]	(1)1x24x24 [25x610x610]	(1)1x24x24 [25x610x610]	(1)1x24x24 [25x610x610]	(1)1x24x24 [25x610x610]
Refrigerant Charge Oz. [g]				
	176 [4990]	176 [4990]	183 [5188]	183 [5188]
Weights				
Net Weight lbs. [kg]	508 [230]	505 [229]	500 [227]	510 [231]
Ship Weight lbs. [kg]	519 [235]	516 [234]	511 [232]	521 [236]

See Page 11 for Notes.

[] Designates Metric Conversions



NOTES:

1. Cooling Performance is rated at 95° F ambient, 80° F entering dry bulb, 67° F entering wet bulb. Gross capacity does not include the effect of fan motor heat. ARI capacity is net and includes the effect of fan motor heat. Units are suitable for operation in CFM range shown in airflow tables. Units are certified in accordance with the Unitary Air Conditioner Equipment certification program, which is based on ARI Standard 210/240 or 360.
2. EER and/or SEER are rated at ARI conditions and in accordance with DOE test procedures.
3. Outdoor Sound Rating shown is tested in accordance with ARI Standard 270.
4. Heating Performance is rated at 47° F ambient, 70° F entering dry bulb for High Temp rating and 17° F ambient, 70° F entering dry bulb for Low Temp rating. Performance ratings do include the effect of fan motor heat.

SYSTEMS PERFORMANCE—RQNL-B SERIES



COOLING PERFORMANCE DATA—RQNL-B024

		ENTERING INDOOR AIR @ 80°F [26.7°C] dbE ①									
		71°F [21.7°C]			67°F [19.4°C]			63°F [17.2°C]			
wbE		880 [415]	800 [378]	720 [340]	880 [415]	800 [378]	720 [340]	880 [415]	800 [378]	720 [340]	
CFM [L/s]		880 [415]	800 [378]	720 [340]	880 [415]	800 [378]	720 [340]	880 [415]	800 [378]	720 [340]	
DR ①		.17	.15	.13	.17	.15	.13	.17	.15	.13	
OUTDOOR DRY BULB TEMPERATURE °F [°C]	75 [23.9]	Total BTUH [kW] Sens BTUH [kW] Power	29.4 [8.62] 18.2 [5.33] 1.5	28.9 [8.47] 17.4 [5.10] 1.5	28.3 [8.29] 16.6 [4.86] 1.5	28.1 [8.24] 21.0 [6.15] 1.5	27.6 [8.09] 20.1 [5.89] 1.5	27.1 [7.94] 19.1 [5.60] 1.5	27.1 [7.94] 22.3 [6.54] 1.5	26.6 [7.80] 21.3 [6.24] 1.5	26.1 [7.65] 20.3 [5.95] 1.5
	80 [26.7]	Total BTUH [kW] Sens BTUH [kW] Power	29.2 [8.56] 18.0 [5.28] 1.6	28.6 [8.38] 17.2 [5.04] 1.6	28.1 [8.24] 16.4 [4.81] 1.6	27.8 [8.15] 20.8 [6.10] 1.6	27.3 [8.00] 19.8 [5.80] 1.6	26.8 [7.85] 18.9 [5.54] 1.6	26.8 [7.85] 22.1 [6.48] 1.6	26.4 [7.74] 21.1 [6.18] 1.6	25.9 [7.59] 20.1 [5.89] 1.6
	85 [29.4]	Total BTUH [kW] Sens BTUH [kW] Power	28.5 [8.35] 17.6 [5.16] 1.7	28.0 [8.21] 16.8 [4.92] 1.7	27.5 [8.06] 16.0 [4.69] 1.7	27.2 [7.97] 20.4 [5.98] 1.7	26.7 [7.83] 19.5 [5.71] 1.7	26.2 [7.68] 18.6 [5.45] 1.7	26.2 [7.68] 21.7 [6.36] 1.7	25.7 [7.53] 20.7 [6.07] 1.7	25.2 [7.39] 19.7 [5.77] 1.7
	90 [32.2]	Total BTUH [kW] Sens BTUH [kW] Power	27.5 [8.06] 17.1 [5.01] 1.8	27.0 [7.91] 16.3 [4.78] 1.8	26.5 [7.77] 15.6 [4.57] 1.8	26.1 [7.65] 19.9 [5.83] 1.8	25.7 [7.53] 19.0 [5.57] 1.8	25.2 [7.39] 18.1 [5.30] 1.8	25.2 [7.39] 21.2 [6.21] 1.8	24.7 [7.24] 20.2 [5.92] 1.8	24.3 [7.12] 19.3 [5.66] 1.8
	95 [35]	Total BTUH [kW] Sens BTUH [kW] Power	26.2 [7.68] 16.5 [4.84] 1.9	25.8 [7.56] 15.8 [4.63] 1.9	25.3 [7.41] 15.0 [4.40] 1.9	24.9 [7.30] 19.3 [5.66] 1.9	24.5 [7.18] 18.5 [5.42] 1.9	24.0 [7.03] 17.6 [5.16] 1.9	23.9 [7.00] 20.6 [6.04] 1.9	23.5 [6.89] 19.7 [5.77] 1.9	23.1 [6.77] 18.8 [5.51] 1.9
	100 [37.8]	Total BTUH [kW] Sens BTUH [kW] Power	24.9 [7.30] 15.9 [4.66] 2.0	24.4 [7.15] 15.2 [4.45] 2.0	24.0 [7.03] 14.5 [4.25] 2.0	23.5 [6.89] 18.7 [5.48] 2.0	23.1 [6.77] 17.9 [5.25] 2.0	22.7 [6.65] 17.0 [4.98] 2.0	22.5 [6.59] 20.0 [5.86] 2.0	22.1 [6.48] 19.1 [5.60] 2.0	21.7 [6.36] 18.2 [5.33] 2.0
	105 [40.6]	Total BTUH [kW] Sens BTUH [kW] Power	23.5 [6.89] 15.2 [4.45] 2.1	23.1 [6.77] 14.5 [4.25] 2.1	22.7 [6.65] 13.9 [4.07] 2.1	22.2 [6.51] 18.0 [5.28] 2.1	21.8 [6.39] 17.2 [5.04] 2.1	21.4 [6.27] 16.4 [4.81] 2.1	21.2 [6.21] 19.3 [5.66] 2.1	20.8 [6.10] 18.5 [5.42] 2.1	20.4 [5.98] 17.6 [5.16] 2.1
	110 [43.3]	Total BTUH [kW] Sens BTUH [kW] Power	22.2 [6.51] 14.6 [4.28] 2.2	21.8 [6.39] 14.0 [4.10] 2.2	21.4 [6.27] 13.3 [3.90] 2.2	20.9 [6.13] 17.4 [5.10] 2.2	20.5 [6.01] 16.7 [4.89] 2.2	20.1 [5.89] 15.9 [4.66] 2.2	19.9 [5.83] 18.7 [5.48] 2.2	19.5 [5.71] 17.9 [5.25] 2.2	19.2 [5.63] 17.0 [4.98] 2.2
	115 [46.1]	Total BTUH [kW] Sens BTUH [kW] Power	21.1 [6.18] 14.0 [4.10] 2.3	20.7 [6.07] 13.4 [3.93] 2.3	20.3 [5.95] 12.8 [3.75] 2.3	19.8 [5.80] 16.9 [4.95] 2.3	19.4 [5.69] 16.1 [4.72] 2.3	19.0 [5.57] 15.4 [4.51] 2.3	18.8 [5.51] 18.1 [5.30] 2.3	18.4 [5.39] 17.3 [5.07] 2.3	18.1 [5.30] 16.5 [4.84] 2.3

DR —Depression ratio
dbE—Entering air dry bulb
wbE—Entering air wet bulb

Total —Total capacity x 1000 BTUH
Sens —Sensible capacity x 1000 BTUH
Power—KW input

NOTES:

① When the entering air dry bulb is other than 80°F [27°C], adjust the sensible capacity from the table by adding $[1.10 \times \text{CFM} \times (1 - \text{DR}) \times (\text{dbE} - 80)]$.

HEATING PERFORMANCE DATA—RQNL-B024

		ENTERING INDOOR AIR @ 80°F [26.7°C] dbE ①									
		60°F [15.5°C]			70°F [21.1°C]			80°F [26.7°C]			
IDB		880 [415]	800 [378]	720 [340]	880 [415]	800 [378]	720 [340]	880 [415]	800 [378]	720 [340]	
CFM [L/s]		880 [415]	800 [378]	720 [340]	880 [415]	800 [378]	720 [340]	880 [415]	800 [378]	720 [340]	
OUTDOOR DRY BULB TEMPERATURE °F [°C]	0 [-17.8]	Total BTUH [kW] Power	8.3 [2.43] 1.4	8.3 [2.43] 1.4	8.2 [2.40] 1.4	7.4 [2.17] 1.6	7.4 [2.17] 1.6	7.3 [2.14] 1.6	6.0 [1.76] 1.8	6.0 [1.76] 1.8	5.9 [1.73] 1.9
	5 [-15]	Total BTUH [kW] Power	10.0 [2.93] 1.4	9.9 [2.90] 1.4	9.8 [2.87] 1.4	9.1 [2.67] 1.6	9.0 [2.64] 1.6	9.0 [2.64] 1.6	7.6 [2.23] 1.8	7.6 [2.23] 1.8	7.5 [2.20] 1.9
	10 [-12.2]	Total BTUH [kW] Power	11.6 [3.40] 1.4	11.5 [3.37] 1.4	11.4 [3.34] 1.5	10.7 [3.14] 1.6	10.6 [3.11] 1.6	10.6 [3.11] 1.6	9.3 [2.73] 1.8	9.2 [2.70] 1.9	9.1 [2.67] 1.9
	15 [-9.4]	Total BTUH [kW] Power	13.2 [3.87] 1.4	13.1 [3.84] 1.5	13.0 [3.81] 1.5	12.3 [3.60] 1.6	12.3 [3.60] 1.6	12.2 [3.58] 1.7	10.9 [3.19] 1.9	10.8 [3.17] 1.9	10.8 [3.17] 1.9
	20 [-6.7]	Total BTUH [kW] Power	14.9 [4.37] 1.5	14.8 [4.34] 1.5	14.7 [4.31] 1.5	14.0 [4.10] 1.6	13.9 [4.07] 1.7	13.8 [4.04] 1.7	12.5 [3.66] 1.9	12.5 [3.66] 1.9	12.4 [3.63] 1.9
	25 [-3.9]	Total BTUH [kW] Power	16.5 [4.84] 1.5	16.4 [4.81] 1.5	16.3 [4.78] 1.5	15.6 [4.57] 1.7	15.5 [4.54] 1.7	15.4 [4.51] 1.7	14.2 [4.16] 1.9	14.1 [4.13] 1.9	14.0 [4.10] 2.0
	30 [-1.1]	Total BTUH [kW] Power	18.1 [5.30] 1.5	18.0 [5.28] 1.5	17.9 [5.25] 1.5	17.2 [5.04] 1.7	17.1 [5.01] 1.7	17.0 [4.98] 1.7	15.8 [4.63] 1.9	15.7 [4.60] 2.0	15.6 [4.57] 2.0
	35 [1.7]	Total BTUH [kW] Power	19.8 [5.80] 1.5	19.6 [5.74] 1.5	19.5 [5.71] 1.6	18.9 [5.54] 1.7	18.7 [5.48] 1.7	18.6 [5.45] 1.7	17.4 [5.10] 1.9	17.3 [5.07] 2.0	17.2 [5.04] 2.0
	40 [4.4]	Total BTUH [kW] Power	21.4 [6.27] 1.5	21.3 [6.24] 1.6	21.1 [6.18] 1.6	20.5 [6.01] 1.7	20.4 [5.98] 1.7	20.2 [5.92] 1.8	19.1 [5.60] 2.0	18.9 [5.54] 2.0	18.8 [5.51] 2.0
	45 [7.2]	Total BTUH [kW] Power	23.0 [6.74] 1.6	22.9 [6.71] 1.6	22.7 [6.65] 1.6	22.1 [6.48] 1.7	22.0 [6.45] 1.8	21.8 [6.39] 1.8	20.7 [6.07] 2.0	20.6 [6.04] 2.0	20.4 [5.98] 2.0
50 [10]	Total BTUH [kW] Power	24.7 [7.24] 1.6	24.5 [7.18] 1.6	24.3 [7.12] 1.6	23.8 [6.98] 1.8	23.6 [6.92] 1.8	23.4 [6.86] 1.8	22.3 [6.54] 2.0	22.2 [6.51] 2.0	22.0 [6.45] 2.1	

IDB—Indoor air dry bulb

[] Designates Metric Conversions



SYSTEMS PERFORMANCE—RQNL-B SERIES

COOLING PERFORMANCE DATA—RQNL-B030

		ENTERING INDOOR AIR @ 80°F [26.7°C] dbE ①									
		71°F [21.7°C]			67°F [19.4°C]			63°F [17.2°C]			
		1100 [519]	1000 [472]	900 [425]	1100 [519]	1000 [472]	900 [425]	1100 [519]	1000 [472]	900 [425]	
		CFM [L/s]									
		DR ①	.02	.18	.16	.02	.18	.16	.02	.18	.16
OUTDOOR DRY BULB TEMPERATURE °F [°C]	75 [23.9]	Total BTUH [kW]	36.1 [10.58]	35.4 [10.37]	34.8 [10.20]	34.1 [9.99]	33.4 [9.79]	32.8 [9.61]	32.7 [9.58]	32.1 [9.41]	31.5 [9.23]
		Sens BTUH [kW]	22.0 [6.45]	21.0 [6.15]	20.0 [5.86]	25.3 [7.41]	24.2 [7.09]	23.0 [6.74]	26.7 [7.83]	25.5 [7.47]	24.3 [7.12]
		Power	1.9	1.9	1.8	1.8	1.8	1.8	1.9	1.9	1.8
	80 [26.7]	Total BTUH [kW]	34.9 [10.23]	34.3 [10.05]	33.6 [9.85]	32.9 [9.64]	32.3 [9.47]	31.7 [9.29]	31.5 [9.23]	31.0 [9.09]	30.4 [8.91]
		Sens BTUH [kW]	21.4 [6.27]	20.4 [5.98]	19.5 [5.71]	24.7 [7.24]	23.6 [6.92]	22.5 [6.59]	26.1 [7.65]	25.0 [7.33]	23.8 [6.98]
		Power	2.0	1.9	1.9	1.9	1.9	1.9	2.0	1.9	1.9
	85 [29.4]	Total BTUH [kW]	33.8 [9.91]	33.2 [9.73]	32.6 [9.55]	31.8 [9.32]	31.2 [9.14]	30.6 [8.97]	30.4 [8.91]	29.8 [8.73]	29.3 [8.59]
		Sens BTUH [kW]	20.8 [6.10]	19.9 [5.83]	19.0 [5.57]	24.1 [7.06]	23.0 [6.74]	22.0 [6.45]	25.5 [7.47]	24.4 [7.15]	23.3 [6.83]
		Power	2.1	2.0	2.0	2.0	2.0	2.0	2.1	2.0	2.0
	90 [32.2]	Total BTUH [kW]	32.6 [9.55]	32.0 [9.38]	31.5 [9.23]	30.6 [8.97]	30.1 [8.82]	29.5 [8.65]	29.3 [8.59]	28.7 [8.41]	28.2 [8.26]
Sens BTUH [kW]		20.2 [5.92]	19.3 [5.66]	18.4 [5.39]	23.5 [6.89]	22.5 [6.59]	21.4 [6.27]	25.0 [7.33]	23.9 [7.00]	22.7 [6.65]	
Power		2.2	2.1	2.1	2.1	2.1	2.1	2.2	2.1	2.1	
95 [35]	Total BTUH [kW]	31.5 [9.23]	30.9 [9.06]	30.4 [8.91]	29.5 [8.65]	29.0 [8.50]	28.4 [8.32]	28.1 [8.24]	27.6 [8.09]	27.1 [7.94]	
	Sens BTUH [kW]	19.7 [5.77]	18.8 [5.51]	17.9 [5.25]	23.0 [6.74]	22.0 [6.45]	20.9 [6.13]	24.4 [7.15]	23.3 [6.83]	22.2 [6.51]	
	Power	2.2	2.2	2.2	2.2	2.2	2.2	2.2	2.2	2.2	
100 [37.8]	Total BTUH [kW]	30.3 [8.88]	29.8 [8.73]	29.3 [8.59]	28.3 [8.29]	27.8 [8.15]	27.3 [8.00]	27.0 [7.91]	26.5 [7.77]	26.0 [7.62]	
	Sens BTUH [kW]	19.2 [5.63]	18.3 [5.36]	17.4 [5.10]	22.4 [6.56]	21.4 [6.27]	20.4 [5.98]	23.9 [7.00]	22.8 [6.68]	21.7 [6.36]	
	Power	2.3	2.3	2.3	2.3	2.3	2.3	2.3	2.3	2.3	
105 [40.6]	Total BTUH [kW]	29.2 [8.56]	28.6 [8.38]	28.1 [8.24]	27.2 [7.97]	26.7 [7.83]	26.2 [7.68]	25.8 [7.56]	25.3 [7.41]	24.9 [7.30]	
	Sens BTUH [kW]	18.6 [5.45]	17.8 [5.22]	16.9 [4.95]	21.9 [6.42]	20.9 [6.13]	19.9 [5.83]	23.3 [6.83]	22.3 [6.54]	21.3 [6.24]	
	Power	2.4	2.4	2.4	2.4	2.4	2.4	2.4	2.4	2.4	
110 [43.3]	Total BTUH [kW]	27.9 [8.18]	27.4 [8.03]	26.9 [7.88]	25.9 [7.59]	25.5 [7.47]	25.0 [7.33]	24.6 [7.21]	24.1 [7.06]	23.7 [6.95]	
	Sens BTUH [kW]	18.1 [5.30]	17.3 [5.07]	16.5 [4.84]	21.4 [6.27]	20.4 [5.98]	19.5 [5.71]	22.8 [6.68]	21.8 [6.39]	20.8 [6.10]	
	Power	2.5	2.5	2.5	2.5	2.5	2.5	2.5	2.5	2.5	
115 [46.1]	Total BTUH [kW]	26.6 [7.80]	26.1 [7.65]	25.7 [7.53]	24.6 [7.21]	24.2 [7.09]	23.7 [6.95]	23.3 [6.83]	22.8 [6.68]	22.4 [6.56]	
	Sens BTUH [kW]	17.5 [5.13]	16.7 [4.89]	15.9 [4.66]	20.8 [6.10]	19.9 [5.83]	19.0 [5.57]	22.2 [6.51]	21.2 [6.21]	20.3 [5.95]	
	Power	2.6	2.6	2.6	2.6	2.6	2.5	2.6	2.6	2.6	

DR —Depression ratio
dbE—Entering air dry bulb
wbE—Entering air wet bulb

Total —Total capacity x 1000 BTUH
Sens —Sensible capacity x 1000 BTUH
Power—KW input

NOTES:

① When the entering air dry bulb is other than 80°F [27°C], adjust the sensible capacity from the table by adding $[1.10 \times \text{CFM} \times (1 - \text{DR}) \times (\text{dbE} - 80)]$.

HEATING PERFORMANCE DATA—RQNL-B030

		IDB	60°F [15.5°C]			70°F [21.1°C]			80°F [26.7°C]		
		CFM [L/s]	1100 [519]	1000 [472]	900 [425]	1100 [519]	1000 [472]	900 [425]	1100 [519]	1000 [472]	900 [425]
OUTDOOR DRY BULB TEMPERATURE °F [°C]	0 [-17.8]	Total BTUH [kW]	9.3 [2.73]	9.3 [2.73]	9.2 [2.70]	7.8 [2.29]	7.7 [2.26]	7.7 [2.26]	6.4 [1.88]	6.3 [1.85]	6.3 [1.85]
		Power	1.6	1.6	1.6	1.8	1.8	1.8	2.0	2.0	2.1
	5 [-15]	Total BTUH [kW]	11.3 [3.31]	11.2 [3.28]	11.1 [3.25]	9.7 [2.84]	9.6 [2.81]	9.6 [2.81]	8.3 [2.43]	8.2 [2.40]	8.2 [2.40]
		Power	1.6	1.6	1.6	1.8	1.8	1.9	2.0	2.1	2.1
	10 [-12.2]	Total BTUH [kW]	13.2 [3.87]	13.1 [3.84]	13.0 [3.81]	11.6 [3.40]	11.5 [3.37]	11.5 [3.37]	10.2 [2.99]	10.1 [2.96]	10.1 [2.96]
		Power	1.6	1.7	1.7	1.9	1.9	1.9	2.1	2.1	2.1
	15 [-9.4]	Total BTUH [kW]	15.1 [4.43]	15.0 [4.40]	14.9 [4.37]	13.5 [3.96]	13.5 [3.96]	13.4 [3.93]	12.1 [3.55]	12.0 [3.52]	12.0 [3.52]
		Power	1.7	1.7	1.7	1.9	1.9	1.9	2.1	2.1	2.2
	20 [-6.7]	Total BTUH [kW]	17.0 [4.98]	16.9 [4.95]	16.8 [4.92]	15.5 [4.54]	15.4 [4.51]	15.3 [4.48]	14.0 [4.10]	13.9 [4.07]	13.8 [4.04]
		Power	1.7	1.7	1.7	1.9	1.9	2.0	2.1	2.2	2.2
25 [-3.9]	Total BTUH [kW]	18.9 [5.54]	18.8 [5.51]	18.7 [5.48]	17.4 [5.10]	17.3 [5.07]	17.1 [5.01]	16.0 [4.69]	15.9 [4.66]	15.7 [4.60]	
	Power	1.7	1.8	1.8	1.9	2.0	2.0	2.2	2.2	2.2	
30 [-1.1]	Total BTUH [kW]	20.9 [6.13]	20.7 [6.07]	20.6 [6.04]	19.3 [5.66]	19.2 [5.63]	19.0 [5.57]	17.9 [5.25]	17.8 [5.22]	17.6 [5.16]	
	Power	1.8	1.8	1.8	2.0	2.0	2.0	2.2	2.2	2.3	
35 [1.7]	Total BTUH [kW]	22.8 [6.68]	22.6 [6.62]	22.5 [6.59]	21.2 [6.21]	21.1 [6.18]	20.9 [6.13]	19.8 [5.80]	19.7 [5.77]	19.5 [5.71]	
	Power	1.8	1.8	1.8	2.0	2.0	2.1	2.2	2.3	2.3	
40 [4.4]	Total BTUH [kW]	24.7 [7.24]	24.5 [7.18]	24.4 [7.15]	23.2 [6.80]	23.0 [6.74]	22.8 [6.68]	21.7 [6.36]	21.6 [6.33]	21.4 [6.27]	
	Power	1.8	1.8	1.9	2.0	2.1	2.1	2.3	2.3	2.3	
45 [7.2]	Total BTUH [kW]	26.6 [7.80]	26.4 [7.74]	26.3 [7.71]	25.1 [7.36]	24.9 [7.30]	24.7 [7.24]	23.7 [6.95]	23.5 [6.89]	23.3 [6.83]	
	Power	1.9	1.9	1.9	2.1	2.1	2.1	2.3	2.3	2.3	
50 [10]	Total BTUH [kW]	28.6 [8.38]	28.4 [8.32]	28.2 [8.26]	27.0 [7.91]	26.8 [7.85]	26.6 [7.80]	25.6 [7.50]	25.4 [7.44]	25.2 [7.39]	
	Power	1.9	1.9	1.9	2.1	2.1	2.1	2.3	2.4	2.4	

IDB—Indoor air dry bulb

[] Designates Metric Conversions

SYSTEMS PERFORMANCE—RQNL-B SERIES



COOLING PERFORMANCE DATA—RQNL-B036

		ENTERING INDOOR AIR @ 80°F [26.7°C] dbE ①									
		71°F [21.7°C]			67°F [19.4°C]			63°F [17.2°C]			
wbE		CFM [L/s]	1380 [651]	1250 [590]	1120 [528]	1380 [651]	1250 [590]	1120 [528]	1380 [651]	1250 [590]	1120 [528]
DR ①			.21	.19	.17	.21	.19	.17	.21	.19	.17
OUTDOOR DRY BULB TEMPERATURE °F [°C]	75 [23.9]	Total BTUH [kW] Sens BTUH [kW] Power	44.5 [13.04] 27.2 [7.97] 2.3	43.7 [12.81] 26.0 [7.62] 2.3	42.9 [12.57] 24.8 [7.27] 2.2	42.5 [12.46] 31.3 [9.17] 2.3	41.7 [12.22] 29.9 [8.76] 2.2	40.9 [11.99] 28.5 [8.35] 2.2	41.3 [12.10] 33.7 [9.88] 2.2	40.6 [11.90] 32.2 [9.44] 2.2	39.8 [11.66] 30.7 [9.00] 2.2
	80 [26.7]	Total BTUH [kW] Sens BTUH [kW] Power	43.4 [12.72] 26.6 [7.80] 2.4	42.6 [12.48] 25.4 [7.44] 2.4	41.8 [12.25] 24.2 [7.09] 2.4	41.3 [12.10] 30.7 [9.00] 2.4	40.6 [11.90] 29.3 [8.59] 2.4	39.9 [11.69] 27.9 [8.18] 2.4	40.2 [11.78] 33.0 [9.67] 2.4	39.5 [11.58] 31.6 [9.26] 2.4	38.8 [11.37] 30.1 [8.82] 2.3
	85 [29.4]	Total BTUH [kW] Sens BTUH [kW] Power	42.1 [12.34] 26.0 [7.62] 2.6	41.3 [12.10] 24.8 [7.27] 2.5	40.6 [11.90] 23.6 [6.92] 2.5	40.0 [11.72] 30.0 [8.79] 2.5	39.3 [11.52] 28.7 [8.41] 2.5	38.6 [11.31] 27.3 [8.00] 2.5	38.9 [11.40] 32.4 [9.50] 2.5	38.2 [11.20] 30.9 [9.06] 2.5	37.5 [10.99] 29.5 [8.65] 2.5
	90 [32.2]	Total BTUH [kW] Sens BTUH [kW] Power	40.6 [11.90] 25.3 [7.41] 2.7	39.9 [11.69] 24.1 [7.06] 2.7	39.1 [11.46] 23.0 [6.74] 2.7	38.5 [11.28] 29.3 [8.59] 2.7	37.9 [11.11] 28.0 [8.21] 2.7	37.2 [10.90] 26.7 [7.83] 2.6	37.4 [10.96] 31.7 [9.29] 2.7	36.7 [10.76] 30.3 [8.88] 2.6	36.1 [10.58] 28.8 [8.44] 2.6
	95 [35]	Total BTUH [kW] Sens BTUH [kW] Power	39.0 [11.43] 24.5 [7.18] 2.9	38.3 [11.22] 23.4 [6.86] 2.8	37.6 [11.02] 22.3 [6.54] 2.8	36.9 [10.81] 28.6 [8.38] 2.8	36.3 [10.64] 27.3 [8.00] 2.8	35.6 [10.43] 26.0 [7.62] 2.8	35.8 [10.49] 30.9 [9.06] 2.8	35.2 [10.32] 29.6 [8.67] 2.8	34.5 [10.11] 28.2 [8.26] 2.8
	100 [37.8]	Total BTUH [kW] Sens BTUH [kW] Power	37.3 [10.93] 23.7 [6.95] 3.0	36.7 [10.76] 22.7 [6.65] 3.0	36.0 [10.55] 21.6 [6.33] 2.9	35.3 [10.35] 27.8 [8.15] 3.0	34.6 [10.14] 26.5 [7.77] 2.9	34.0 [9.96] 25.3 [7.41] 2.9	34.1 [9.99] 30.2 [8.85] 3.0	33.5 [9.82] 28.8 [8.44] 2.9	32.9 [9.64] 27.5 [8.06] 2.9
	105 [40.6]	Total BTUH [kW] Sens BTUH [kW] Power	35.6 [10.43] 22.9 [6.71] 3.1	35.0 [10.26] 21.9 [6.42] 3.1	34.4 [10.08] 20.9 [6.13] 3.1	33.6 [9.85] 27.0 [7.91] 3.1	33.0 [9.67] 25.8 [7.56] 3.1	32.4 [9.50] 24.6 [7.21] 3.1	32.4 [9.50] 29.4 [8.62] 3.1	31.9 [9.35] 28.1 [8.24] 3.1	31.3 [9.17] 26.7 [7.83] 3.0
	110 [43.3]	Total BTUH [kW] Sens BTUH [kW] Power	34.0 [9.96] 22.1 [6.48] 3.3	33.4 [9.79] 21.1 [6.18] 3.3	32.7 [9.58] 20.1 [5.89] 3.2	31.9 [9.35] 26.2 [7.68] 3.3	31.3 [9.17] 25.0 [7.33] 3.2	30.8 [9.03] 23.8 [6.98] 3.2	30.8 [9.03] 28.5 [8.35] 3.2	30.2 [8.85] 27.3 [8.00] 3.2	29.7 [8.70] 26.0 [7.62] 3.2
	115 [46.1]	Total BTUH [kW] Sens BTUH [kW] Power	32.4 [9.50] 21.3 [6.24] 3.4	31.8 [9.32] 20.3 [5.95] 3.4	31.2 [9.14] 19.4 [5.69] 3.4	30.3 [8.88] 25.3 [7.41] 3.4	29.8 [8.73] 24.2 [7.09] 3.4	29.2 [8.56] 23.1 [6.77] 3.3	29.2 [8.56] 27.7 [8.12] 3.4	28.6 [8.38] 26.5 [7.77] 3.4	28.1 [8.24] 25.2 [7.39] 3.3

DR —Depression ratio
dbE —Entering air dry bulb
wbE—Entering air wet bulb

Total —Total capacity x 1000 BTUH
Sens —Sensible capacity x 1000 BTUH
Power—KW input

NOTES:

① When the entering air dry bulb is other than 80°F [27°C], adjust the sensible capacity from the table by adding $[1.10 \times \text{CFM} \times (1 - \text{DR}) \times (\text{dbE} - 80)]$.

HEATING PERFORMANCE DATA—RQNL-B036

		ENTERING INDOOR AIR @ 80°F [26.7°C] dbE ①									
		60°F [15.5°C]			70°F [21.1°C]			80°F [26.7°C]			
IDB		CFM [L/s]	1380 [651]	1250 [590]	1120 [528]	1380 [651]	1250 [590]	1120 [528]	1380 [651]	1250 [590]	1120 [528]
OUTDOOR DRY BULB TEMPERATURE °F [°C]	0 [-17.8]	Total BTUH [kW] Power	11.9 [3.49] 1.8	11.9 [3.49] 1.8	11.8 [3.46] 1.9	9.9 [2.90] 2.1	9.8 [2.87] 2.1	9.8 [2.87] 2.1	8.5 [2.49] 2.4	8.5 [2.49] 2.4	8.4 [2.46] 2.4
	5 [-15]	Total BTUH [kW] Power	14.4 [4.22] 1.9	14.3 [4.19] 1.9	14.2 [4.16] 1.9	12.4 [3.63] 2.1	12.3 [3.60] 2.1	12.2 [3.58] 2.2	11.0 [3.22] 2.4	10.9 [3.19] 2.4	10.8 [3.17] 2.5
	10 [-12.2]	Total BTUH [kW] Power	16.8 [4.92] 1.9	16.7 [4.89] 1.9	16.6 [4.86] 1.9	14.8 [4.34] 2.2	14.7 [4.31] 2.2	14.6 [4.28] 2.2	13.4 [3.93] 2.4	13.3 [3.90] 2.5	13.2 [3.87] 2.5
	15 [-9.4]	Total BTUH [kW] Power	19.3 [5.66] 1.9	19.2 [5.63] 2.0	19.0 [5.57] 2.0	17.3 [5.07] 2.2	17.1 [5.01] 2.2	17.0 [4.98] 2.2	15.9 [4.66] 2.5	15.8 [4.63] 2.5	15.7 [4.60] 2.5
	20 [-6.7]	Total BTUH [kW] Power	21.7 [6.36] 2.0	21.6 [6.33] 2.0	21.4 [6.27] 2.0	19.7 [5.77] 2.2	19.6 [5.74] 2.3	19.4 [5.69] 2.3	18.3 [5.36] 2.5	18.2 [5.33] 2.6	18.1 [5.30] 2.6
	25 [-3.9]	Total BTUH [kW] Power	24.2 [7.09] 2.0	24.0 [7.03] 2.0	23.9 [7.00] 2.1	22.2 [6.51] 2.3	22.0 [6.45] 2.3	21.8 [6.39] 2.3	20.8 [6.10] 2.6	20.6 [6.04] 2.6	20.5 [6.01] 2.6
	30 [-1.1]	Total BTUH [kW] Power	26.7 [7.83] 2.1	26.5 [7.77] 2.1	26.3 [7.71] 2.1	24.6 [7.21] 2.3	24.4 [7.15] 2.3	24.3 [7.12] 2.4	23.2 [6.80] 2.6	23.1 [6.77] 2.6	22.9 [6.71] 2.7
	35 [1.7]	Total BTUH [kW] Power	29.1 [8.53] 2.1	28.9 [8.47] 2.1	28.7 [8.41] 2.2	27.1 [7.94] 2.4	26.9 [7.88] 2.4	26.7 [7.83] 2.4	25.7 [7.53] 2.6	25.5 [7.47] 2.7	25.3 [7.41] 2.7
	40 [4.4]	Total BTUH [kW] Power	31.6 [9.26] 2.1	31.3 [9.17] 2.2	31.1 [9.11] 2.2	29.5 [8.65] 2.4	29.3 [8.59] 2.4	29.1 [8.53] 2.5	28.1 [8.24] 2.7	27.9 [8.18] 2.7	27.7 [8.12] 2.8
	45 [7.2]	Total BTUH [kW] Power	34.0 [9.96] 2.2	33.8 [9.91] 2.2	33.5 [9.82] 2.2	32.0 [9.38] 2.4	31.7 [9.29] 2.5	31.5 [9.23] 2.5	30.6 [8.97] 2.7	30.4 [8.91] 2.8	30.2 [8.85] 2.8
50 [10]	Total BTUH [kW] Power	36.5 [10.70] 2.2	36.2 [10.61] 2.2	35.9 [10.52] 2.3	34.4 [10.08] 2.5	34.2 [10.02] 2.5	33.9 [9.94] 2.5	33.0 [9.67] 2.8	32.8 [9.61] 2.8	32.6 [9.55] 2.8	

IDB—Indoor air dry bulb

[] Designates Metric Conversions



SYSTEMS PERFORMANCE—RQNL-B SERIES

COOLING PERFORMANCE DATA—RQNL-B042

		ENTERING INDOOR AIR @ 80°F [26.7°C] dbE ①										
		wbE	71°F [21.7°C]			67°F [19.4°C]			63°F [17.2°C]			
		CFM [L/s]	1540 [727]	1400 [661]	1260 [595]	1540 [727]	1400 [661]	1260 [595]	1540 [727]	1400 [661]	1260 [595]	
		DR ①	.17	.15	.14	.17	.15	.14	.17	.15	.14	
OUTDOOR DRY BULB TEMPERATURE °F [°C]	75 [23.9]	Total BTUH [kW]	53.9 [15.80]	52.9 [15.50]	51.9 [15.21]	50.9 [14.92]	50.0 [14.65]	49.1 [14.39]	48.1 [14.10]	47.3 [13.86]	46.4 [13.60]	
		Sens BTUH [kW]	32.2 [9.44]	30.7 [9.00]	29.3 [8.59]	27.1 [7.94]	25.5 [7.50]	24.2 [7.06]	23.1 [6.77]	22.1 [6.45]	21.1 [6.15]	20.1 [5.86]
		Power	2.9	2.9	2.9	2.9	2.9	2.9	2.9	2.9	2.9	2.9
	80 [26.7]	Total BTUH [kW]	52.0 [15.24]	51.0 [14.95]	50.1 [14.68]	49.0 [14.36]	48.1 [14.10]	47.2 [13.83]	46.2 [13.54]	45.4 [13.31]	44.6 [13.07]	
		Sens BTUH [kW]	31.3 [9.17]	29.9 [8.76]	28.5 [8.35]	26.4 [7.74]	24.9 [7.30]	23.5 [6.89]	22.4 [6.60]	21.4 [6.31]	20.5 [6.03]	
		Power	3.1	3.1	3.1	3.1	3.1	3.1	3.1	3.1	3.1	
	85 [29.4]	Total BTUH [kW]	50.3 [14.74]	49.4 [14.48]	48.5 [14.21]	47.3 [13.86]	46.5 [13.63]	45.6 [13.36]	44.6 [13.07]	43.8 [12.84]	43.0 [12.60]	
		Sens BTUH [kW]	30.5 [8.94]	29.2 [8.56]	27.8 [8.15]	25.7 [7.53]	24.2 [7.06]	22.9 [6.64]	21.8 [6.35]	20.9 [6.06]	20.1 [5.82]	
		Power	3.3	3.3	3.2	3.2	3.2	3.2	3.2	3.2	3.2	
	90 [32.2]	Total BTUH [kW]	48.7 [14.27]	47.9 [14.04]	47.0 [13.77]	45.8 [13.42]	44.9 [13.16]	44.1 [12.92]	43.0 [12.60]	42.2 [12.37]	41.5 [12.16]	
Sens BTUH [kW]		29.8 [8.73]	28.4 [8.32]	27.1 [7.94]	25.0 [7.30]	23.5 [6.89]	22.4 [6.60]	21.4 [6.31]	20.5 [6.03]	19.7 [5.79]		
Power		3.4	3.4	3.4	3.4	3.4	3.4	3.4	3.4	3.4		
95 [35]	Total BTUH [kW]	47.2 [13.83]	46.4 [13.60]	45.5 [13.33]	44.2 [12.95]	43.4 [12.72]	42.7 [12.51]	41.5 [12.16]	40.7 [11.93]	40.0 [11.72]		
	Sens BTUH [kW]	29.0 [8.50]	27.7 [8.12]	26.4 [7.74]	24.3 [7.10]	22.8 [6.67]	21.7 [6.38]	20.8 [6.09]	19.9 [5.80]	19.1 [5.56]		
	Power	3.6	3.6	3.6	3.6	3.6	3.6	3.6	3.6	3.6		
100 [37.8]	Total BTUH [kW]	45.6 [13.36]	44.8 [13.13]	44.0 [12.90]	42.6 [12.48]	41.9 [12.28]	41.1 [12.05]	39.9 [11.69]	39.2 [11.49]	38.5 [11.28]		
	Sens BTUH [kW]	28.2 [8.26]	26.9 [7.88]	25.7 [7.53]	23.6 [6.90]	22.1 [6.47]	21.0 [6.18]	20.1 [5.89]	19.2 [5.60]	18.4 [5.36]		
	Power	3.8	3.8	3.7	3.8	3.7	3.7	3.8	3.7	3.7		
105 [40.6]	Total BTUH [kW]	43.8 [12.84]	43.0 [12.60]	42.3 [12.40]	40.8 [11.96]	40.1 [11.75]	39.4 [11.55]	38.1 [11.17]	37.4 [10.96]	36.7 [10.76]		
	Sens BTUH [kW]	27.4 [8.03]	26.1 [7.65]	24.9 [7.30]	22.8 [6.90]	21.3 [6.47]	20.2 [6.18]	19.3 [5.89]	18.4 [5.60]	17.6 [5.36]		
	Power	4.0	3.9	3.9	3.9	3.9	3.9	3.9	3.9	3.9		
110 [43.3]	Total BTUH [kW]	41.7 [12.22]	41.0 [12.02]	40.2 [11.78]	38.8 [11.37]	38.1 [11.17]	37.4 [10.96]	36.0 [10.55]	35.4 [10.37]	34.7 [10.17]		
	Sens BTUH [kW]	26.4 [7.74]	25.2 [7.39]	24.1 [7.06]	22.0 [6.64]	20.5 [6.21]	19.4 [5.92]	18.5 [5.63]	17.6 [5.34]	16.8 [5.10]		
	Power	4.1	4.1	4.1	4.1	4.1	4.0	4.1	4.1	4.0		
115 [46.1]	Total BTUH [kW]	39.3 [11.52]	38.6 [11.31]	37.9 [11.11]	36.3 [10.64]	35.6 [10.43]	35.0 [10.26]	33.5 [9.82]	32.9 [9.64]	32.3 [9.47]		
	Sens BTUH [kW]	25.4 [7.44]	24.2 [7.09]	23.1 [6.77]	21.0 [6.35]	19.5 [5.92]	18.4 [5.63]	17.5 [5.34]	16.6 [5.05]	15.8 [4.81]		
	Power	4.3	4.3	4.2	4.3	4.2	4.2	4.3	4.2	4.2		

DR —Depression ratio
dbE—Entering air dry bulb
wbE—Entering air wet bulb

Total —Total capacity x 1000 BTUH
Sens —Sensible capacity x 1000 BTUH
Power—KW input

NOTES:

① When the entering air dry bulb is other than 80°F [27°C], adjust the sensible capacity from the table by adding $[1.10 \times \text{CFM} \times (1 - \text{DR}) \times (\text{dbE} - 80)]$.

HEATING PERFORMANCE DATA—RQNL-B042

		IDB	60°F [15.5°C]			70°F [21.1°C]			80°F [26.7°C]		
		CFM [L/s]	1540 [727]	1400 [661]	1260 [595]	1540 [727]	1400 [661]	1260 [595]	1540 [727]	1400 [661]	1260 [595]
OUTDOOR DRY BULB TEMPERATURE °F [°C]	0 [-17.8]	Total BTUH [kW]	13.9 [4.07]	13.8 [4.04]	13.7 [4.02]	12.9 [3.78]	12.8 [3.75]	12.8 [3.75]	11.2 [3.28]	11.1 [3.25]	11.1 [3.25]
		Power	2.6	2.6	2.6	3.0	3.0	3.1	3.3	3.4	3.4
	5 [-15]	Total BTUH [kW]	16.9 [4.95]	16.8 [4.92]	16.7 [4.89]	16.0 [4.69]	15.8 [4.63]	15.7 [4.60]	14.2 [4.16]	14.1 [4.13]	14.0 [4.10]
		Power	2.6	2.6	2.7	3.0	3.1	3.1	3.4	3.4	3.5
	10 [-12.2]	Total BTUH [kW]	20.0 [5.86]	19.8 [5.80]	19.7 [5.77]	19.0 [5.57]	18.8 [5.51]	18.7 [5.48]	17.3 [5.07]	17.1 [5.01]	17.0 [4.98]
		Power	2.6	2.7	2.7	3.1	3.1	3.1	3.4	3.5	3.5
	15 [-9.4]	Total BTUH [kW]	23.0 [6.74]	22.8 [6.68]	22.6 [6.62]	22.0 [6.45]	21.8 [6.39]	21.7 [6.36]	20.3 [5.95]	20.1 [5.89]	20.0 [5.86]
		Power	2.7	2.7	2.7	3.1	3.1	3.2	3.5	3.5	3.5
	20 [-6.7]	Total BTUH [kW]	26.0 [7.62]	25.8 [7.56]	25.6 [7.50]	25.0 [7.33]	24.8 [7.27]	24.7 [7.24]	23.3 [6.83]	23.1 [6.77]	23.0 [6.74]
		Power	2.7	2.7	2.8	3.1	3.2	3.2	3.5	3.5	3.6
25 [-3.9]	Total BTUH [kW]	29.0 [8.50]	28.8 [8.44]	28.6 [8.38]	28.0 [8.21]	27.8 [8.15]	27.6 [8.09]	26.3 [7.71]	26.1 [7.65]	25.9 [7.59]	
	Power	2.8	2.8	2.8	3.2	3.2	3.3	3.5	3.6	3.6	
30 [-1.1]	Total BTUH [kW]	32.0 [9.38]	31.8 [9.32]	31.6 [9.26]	31.1 [9.11]	30.8 [9.03]	30.6 [8.97]	29.3 [8.59]	29.1 [8.53]	28.9 [8.47]	
	Power	2.8	2.8	2.9	3.2	3.2	3.3	3.6	3.6	3.7	
35 [1.7]	Total BTUH [kW]	35.1 [10.29]	34.8 [10.20]	34.6 [10.14]	34.1 [9.99]	33.8 [9.91]	33.6 [9.85]	32.4 [9.50]	32.1 [9.41]	31.9 [9.35]	
	Power	2.8	2.9	2.9	3.2	3.3	3.3	3.6	3.6	3.7	
40 [4.4]	Total BTUH [kW]	38.1 [11.17]	37.8 [11.08]	37.5 [10.99]	37.1 [10.87]	36.8 [10.79]	36.6 [10.73]	35.4 [10.37]	35.1 [10.29]	34.9 [10.23]	
	Power	2.9	2.9	2.9	3.3	3.3	3.4	3.6	3.7	3.7	
45 [7.2]	Total BTUH [kW]	41.1 [12.05]	40.8 [11.96]	40.5 [11.87]	40.1 [11.75]	39.8 [11.66]	39.6 [11.61]	38.4 [11.25]	38.1 [11.17]	37.9 [11.11]	
	Power	2.9	2.9	3.0	3.3	3.4	3.4	3.7	3.7	3.8	
50 [10]	Total BTUH [kW]	44.1 [12.92]	43.8 [12.84]	43.5 [12.75]	43.1 [12.63]	42.8 [12.54]	42.5 [12.46]	41.4 [12.13]	41.1 [12.05]	40.8 [11.96]	
	Power	2.9	3.0	3.0	3.4	3.4	3.4	3.7	3.8	3.8	

IDB—Indoor air dry bulb

[] Designates Metric Conversions



COOLING PERFORMANCE DATA—RQNL-B048

		ENTERING INDOOR AIR @ 80°F [26.7°C] dbE ①									
		wbE			71°F [21.7°C]			67°F [19.4°C]			63°F [17.2°C]
		CFM [L/s]	1760 [831]	1600 [755]	1440 [680]	1760 [831]	1600 [755]	1440 [680]	1760 [831]	1600 [755]	1440 [680]
		DR ①	.15	.13	.11	.15	.13	.11	.15	.13	.11
OUTDOOR DRY BULB TEMPERATURE °F [°C]	75 [23.9]	Total BTUH [kW] Sens BTUH [kW] Power	60.4 [17.70] 37.4 [10.96] 3.2	59.3 [17.38] 35.7 [10.46] 3.2	58.3 [17.09] 34.1 [9.99] 3.2	57.1 [16.73] 42.7 [12.51] 3.2	56.1 [16.44] 40.8 [11.96] 3.2	55.0 [16.12] 38.9 [11.40] 3.1	54.5 [15.97] 45.0 [13.19] 3.2	53.5 [15.68] 43.0 [12.60] 3.1	52.5 [15.39] 41.0 [12.02] 3.1
	80 [26.7]	Total BTUH [kW] Sens BTUH [kW] Power	58.8 [17.23] 36.6 [10.73] 3.4	57.8 [16.94] 35.0 [10.26] 3.4	56.7 [16.62] 33.3 [9.76] 3.3	55.5 [16.27] 41.9 [12.28] 3.4	54.5 [15.97] 40.0 [11.72] 3.4	53.5 [15.68] 38.2 [11.20] 3.3	52.9 [15.50] 44.2 [12.95] 3.4	51.9 [15.21] 42.2 [12.37] 3.3	51.0 [14.95] 40.3 [11.81] 3.3
	85 [29.4]	Total BTUH [kW] Sens BTUH [kW] Power	57.0 [16.71] 35.7 [10.46] 3.6	56.0 [16.41] 34.1 [9.99] 3.6	55.0 [16.12] 32.5 [9.52] 3.5	53.7 [15.74] 41.0 [12.02] 3.6	52.7 [15.44] 39.2 [11.49] 3.5	51.8 [15.18] 37.3 [10.93] 3.5	51.1 [14.98] 43.3 [12.69] 3.5	50.2 [14.71] 41.4 [12.13] 3.5	49.3 [14.45] 39.4 [11.55] 3.5
	90 [32.2]	Total BTUH [kW] Sens BTUH [kW] Power	55.1 [16.15] 34.8 [10.20] 3.8	54.1 [15.86] 33.2 [9.73] 3.7	53.1 [15.56] 31.7 [9.29] 3.7	51.7 [15.15] 40.1 [11.75] 3.8	50.8 [14.89] 38.3 [11.22] 3.7	49.9 [14.62] 36.5 [10.70] 3.7	49.1 [14.39] 42.4 [12.43] 3.7	48.3 [14.16] 40.5 [11.87] 3.7	47.4 [13.89] 38.6 [11.31] 3.7
	95 [35]	Total BTUH [kW] Sens BTUH [kW] Power	53.1 [15.56] 33.8 [9.91] 4.0	52.1 [15.27] 32.3 [9.47] 3.9	51.2 [15.01] 30.8 [9.03] 3.9	49.8 [14.59] 39.1 [11.46] 3.9	48.9 [14.33] 37.4 [10.96] 3.9	48.0 [14.07] 35.6 [10.43] 3.9	47.2 [13.83] 41.4 [12.13] 3.9	46.3 [13.57] 39.6 [11.61] 3.9	45.5 [13.33] 37.7 [11.05] 3.9
	100 [37.8]	Total BTUH [kW] Sens BTUH [kW] Power	51.1 [14.98] 32.9 [9.64] 4.2	50.2 [14.71] 31.4 [9.20] 4.1	49.3 [14.45] 29.9 [8.76] 4.1	47.8 [14.01] 38.2 [11.20] 4.1	46.9 [13.75] 36.5 [10.70] 4.1	46.1 [13.51] 34.8 [10.20] 4.1	45.2 [13.25] 40.5 [11.87] 4.1	44.4 [13.01] 38.7 [11.34] 4.1	43.6 [12.78] 36.9 [10.81] 4.0
	105 [40.6]	Total BTUH [kW] Sens BTUH [kW] Power	49.3 [14.45] 32.0 [9.38] 4.3	48.4 [14.18] 30.6 [8.97] 4.3	47.5 [13.92] 29.2 [8.56] 4.3	46.0 [13.48] 37.3 [10.93] 4.3	45.1 [13.22] 35.7 [10.46] 4.3	44.3 [12.98] 34.0 [9.96] 4.2	43.4 [12.72] 39.6 [11.61] 4.3	42.6 [12.48] 37.9 [11.11] 4.3	41.8 [12.25] 36.1 [10.58] 4.2
	110 [43.3]	Total BTUH [kW] Sens BTUH [kW] Power	47.6 [13.95] 31.3 [9.17] 4.5	46.8 [13.72] 29.9 [8.76] 4.5	45.9 [13.45] 28.5 [8.35] 4.5	44.3 [12.98] 36.6 [10.73] 4.5	43.5 [12.75] 34.9 [10.23] 4.5	42.7 [12.51] 33.3 [9.76] 4.4	41.7 [12.22] 38.9 [11.40] 4.5	41.0 [12.02] 37.1 [10.87] 4.4	40.2 [11.78] 35.4 [10.37] 4.4
	115 [46.1]	Total BTUH [kW] Sens BTUH [kW] Power	46.3 [13.57] 30.7 [9.00] 4.7	45.5 [13.33] 29.3 [8.59] 4.7	44.6 [13.07] 27.9 [8.18] 4.6	43.0 [12.60] 36.0 [10.55] 4.7	42.2 [12.37] 34.4 [10.08] 4.7	41.4 [12.13] 32.8 [9.61] 4.6	40.4 [11.84] 38.3 [11.22] 4.7	39.6 [11.61] 36.6 [10.73] 4.6	38.9 [11.40] 34.8 [10.20] 4.6

DR —Depression ratio
dbE—Entering air dry bulb
wbE—Entering air wet bulb

Total —Total capacity x 1000 BTUH
Sens —Sensible capacity x 1000 BTUH
Power—KW input

NOTES:

① When the entering air dry bulb is other than 80°F [27°C], adjust the sensible capacity from the table by adding $[1.10 \times \text{CFM} \times (1 - \text{DR}) \times (\text{dbE} - 80)]$.

HEATING PERFORMANCE DATA—RQNL-B048

		IDB	60°F [15.5°C]			70°F [21.1°C]			80°F [26.7°C]		
		CFM [L/s]	1760 [831]	1600 [755]	1440 [680]	1760 [831]	1600 [755]	1440 [680]	1760 [831]	1600 [755]	1440 [680]
OUTDOOR DRY BULB TEMPERATURE °F [°C]	0 [-17.8]	Total BTUH [kW] Power	16.9 [4.95] 2.6	16.8 [4.92] 2.6	16.7 [4.89] 2.6	15.4 [4.51] 3.0	15.3 [4.48] 3.0	15.2 [4.45] 3.0	14.4 [4.22] 3.4	14.3 [4.19] 3.5	14.2 [4.16] 3.5
	5 [-15]	Total BTUH [kW] Power	20.1 [5.89] 2.6	19.9 [5.83] 2.6	19.8 [5.80] 2.7	18.6 [5.45] 3.0	18.5 [5.42] 3.0	18.3 [5.36] 3.1	17.6 [5.16] 3.5	17.5 [5.13] 3.5	17.3 [5.07] 3.5
	10 [-12.2]	Total BTUH [kW] Power	23.2 [6.80] 2.7	23.1 [6.77] 2.7	22.9 [6.71] 2.7	21.8 [6.39] 3.1	21.6 [6.33] 3.1	21.5 [6.30] 3.1	20.7 [6.07] 3.5	20.6 [6.04] 3.6	20.4 [5.98] 3.6
	15 [-9.4]	Total BTUH [kW] Power	26.4 [7.74] 2.7	26.2 [7.68] 2.8	26.0 [7.62] 2.8	24.9 [7.30] 3.1	24.7 [7.24] 3.2	24.6 [7.21] 3.2	23.9 [7.00] 3.6	23.7 [6.95] 3.6	23.6 [6.92] 3.7
	20 [-6.7]	Total BTUH [kW] Power	29.5 [8.65] 2.8	29.3 [8.59] 2.8	29.1 [8.53] 2.8	28.1 [8.24] 3.2	27.9 [8.18] 3.2	27.7 [8.12] 3.2	27.1 [7.94] 3.6	26.9 [7.88] 3.7	26.7 [7.83] 3.7
	25 [-3.9]	Total BTUH [kW] Power	32.7 [9.58] 2.8	32.5 [9.52] 2.9	32.2 [9.44] 2.9	31.2 [9.14] 3.2	31.0 [9.09] 3.3	30.8 [9.03] 3.3	30.2 [8.85] 3.7	30.0 [8.79] 3.7	29.8 [8.73] 3.8
	30 [-1.1]	Total BTUH [kW] Power	35.9 [10.52] 2.9	35.6 [10.43] 2.9	35.4 [10.37] 2.9	34.4 [10.08] 3.3	34.1 [9.99] 3.3	33.9 [9.94] 3.4	33.4 [9.79] 3.7	33.1 [9.70] 3.8	32.9 [9.64] 3.8
	35 [1.7]	Total BTUH [kW] Power	39.0 [11.43] 2.9	38.7 [11.34] 3.0	38.5 [11.28] 3.0	37.5 [10.99] 3.3	37.3 [10.93] 3.4	37.0 [10.84] 3.4	36.5 [10.70] 3.8	36.3 [10.64] 3.8	36.0 [10.55] 3.9
	40 [4.4]	Total BTUH [kW] Power	42.2 [12.37] 3.0	41.9 [12.28] 3.0	41.6 [12.19] 3.1	40.7 [11.93] 3.4	40.4 [11.84] 3.4	40.1 [11.75] 3.5	39.7 [11.63] 3.8	39.4 [11.55] 3.9	39.1 [11.46] 3.9
	45 [7.2]	Total BTUH [kW] Power	45.3 [13.28] 3.0	45.0 [13.19] 3.1	44.7 [13.10] 3.1	43.9 [12.87] 3.4	43.6 [12.78] 3.5	43.2 [12.66] 3.5	42.8 [12.54] 3.9	42.5 [12.46] 3.9	42.2 [12.37] 4.0
50 [10]	Total BTUH [kW] Power	48.5 [14.21] 3.1	48.1 [14.10] 3.1	47.8 [14.01] 3.2	47.0 [13.77] 3.5	46.7 [13.69] 3.5	46.4 [13.60] 3.6	46.0 [13.48] 3.9	45.7 [13.39] 4.0	45.3 [13.28] 4.0	

IDB—Indoor air dry bulb

[] Designates Metric Conversions

SYSTEMS PERFORMANCE—RQPL-B SERIES



COOLING PERFORMANCE DATA—RQPL-B024

		ENTERING INDOOR AIR @ 80°F [26.7°C] dbE ①									
		71°F [21.7°C]			67°F [19.4°C]			63°F [17.2°C]			
		CFM [L/s]	940 [444]	850 [401]	760 [359]	940 [444]	850 [401]	760 [359]	940 [444]	850 [401]	760 [359]
		DR ①	.15	.13	.11	.15	.13	.11	.15	.13	.11
OUTDOOR DRY BULB TEMPERATURE °F [°C]	75 [23.9]	Total BTUH [kW] Sens BTUH [kW] Power	29.9 [8.76] 19.2 [5.63] 1.5	29.4 [8.62] 18.4 [5.39] 1.5	28.8 [8.44] 17.5 [5.13] 1.5	28.6 [8.38] 22.0 [6.45] 1.5	28.0 [8.21] 21.0 [6.15] 1.5	27.5 [8.06] 20.1 [5.89] 1.5	27.6 [8.09] 23.3 [6.83] 1.5	27.1 [7.94] 22.3 [6.54] 1.5	26.6 [7.80] 21.2 [6.21] 1.5
	80 [26.7]	Total BTUH [kW] Sens BTUH [kW] Power	29.7 [8.70] 19.0 [5.57] 1.6	29.1 [8.53] 18.1 [5.30] 1.6	28.6 [8.38] 17.3 [5.07] 1.6	28.3 [8.29] 21.8 [6.39] 1.6	27.8 [8.15] 20.8 [6.10] 1.6	27.3 [8.00] 19.9 [5.83] 1.6	27.3 [8.00] 23.1 [6.77] 1.6	26.8 [7.85] 22.1 [6.48] 1.6	26.4 [7.74] 21.0 [6.15] 1.6
	85 [29.4]	Total BTUH [kW] Sens BTUH [kW] Power	29.0 [8.50] 18.6 [5.45] 1.7	28.5 [8.35] 17.8 [5.22] 1.7	27.9 [8.18] 16.9 [4.95] 1.7	27.6 [8.09] 21.4 [6.27] 1.7	27.2 [7.97] 20.5 [6.01] 1.7	26.7 [7.83] 19.5 [5.71] 1.7	26.7 [7.83] 22.7 [6.65] 1.7	26.2 [7.68] 21.7 [6.36] 1.7	25.7 [7.53] 20.7 [6.07] 1.7
	90 [32.2]	Total BTUH [kW] Sens BTUH [kW] Power	28.0 [8.21] 18.1 [5.30] 1.8	27.5 [8.06] 17.3 [5.07] 1.8	27.0 [7.91] 16.5 [4.84] 1.8	26.6 [7.80] 20.9 [6.13] 1.8	26.2 [7.68] 20.0 [5.86] 1.8	25.7 [7.53] 19.1 [5.60] 1.8	25.6 [7.50] 22.2 [6.51] 1.8	25.2 [7.39] 21.2 [6.21] 1.8	24.7 [7.24] 20.2 [5.92] 1.8
	95 [35]	Total BTUH [kW] Sens BTUH [kW] Power	26.7 [7.83] 17.5 [5.13] 1.9	26.3 [7.71] 16.7 [4.89] 1.9	25.8 [7.56] 16.0 [4.69] 1.9	25.4 [7.44] 20.4 [5.98] 1.9	24.9 [7.30] 19.4 [5.69] 1.9	24.5 [7.18] 18.5 [5.42] 1.9	24.4 [7.15] 21.6 [6.33] 1.9	24.0 [7.03] 20.7 [6.07] 1.9	23.5 [6.89] 19.7 [5.77] 1.9
	100 [37.8]	Total BTUH [kW] Sens BTUH [kW] Power	25.4 [7.44] 16.9 [4.95] 2.0	24.9 [7.30] 16.1 [4.72] 2.0	24.5 [7.18] 15.4 [4.51] 2.0	24.0 [7.03] 19.7 [5.77] 2.0	23.6 [6.92] 18.8 [5.51] 2.0	23.2 [6.80] 18.0 [5.28] 2.0	23.0 [6.74] 21.0 [6.15] 2.0	22.6 [6.62] 20.1 [5.89] 2.0	22.2 [6.51] 19.1 [5.60] 2.0
	105 [40.6]	Total BTUH [kW] Sens BTUH [kW] Power	24.0 [7.03] 16.3 [4.78] 2.1	23.6 [6.92] 15.5 [4.54] 2.1	23.1 [6.77] 14.8 [4.34] 2.1	22.6 [6.62] 19.1 [5.60] 2.1	22.2 [6.51] 18.2 [5.33] 2.1	21.8 [6.39] 17.4 [5.10] 2.1	21.7 [6.36] 20.4 [5.98] 2.1	21.3 [6.24] 19.5 [5.71] 2.1	20.9 [6.13] 18.5 [5.42] 2.1
	110 [43.3]	Total BTUH [kW] Sens BTUH [kW] Power	22.7 [6.65] 15.6 [4.57] 2.2	22.3 [6.54] 14.9 [4.37] 2.2	21.9 [6.42] 14.2 [4.16] 2.2	21.4 [6.27] 18.5 [5.42] 2.2	21.0 [6.15] 17.6 [5.16] 2.2	20.6 [6.04] 16.8 [4.92] 2.2	20.4 [5.98] 19.7 [5.77] 2.2	20.0 [5.86] 18.9 [5.54] 2.2	19.6 [5.74] 18.0 [5.28] 2.2
	115 [46.1]	Total BTUH [kW] Sens BTUH [kW] Power	21.6 [6.33] 15.1 [4.43] 2.3	21.2 [6.21] 14.4 [4.22] 2.3	20.8 [6.10] 13.7 [4.02] 2.3	20.2 [5.92] 17.9 [5.25] 2.3	19.9 [5.83] 17.1 [5.01] 2.3	19.5 [5.71] 16.3 [4.78] 2.3	19.3 [5.66] 19.2 [5.63] 2.3	18.9 [5.54] 18.3 [5.36] 2.3	18.6 [5.45] 17.5 [5.13] 2.3

DR —Depression ratio
dbE—Entering air dry bulb
wbE—Entering air wet bulb

Total —Total capacity x 1000 BTUH
Sens —Sensible capacity x 1000 BTUH
Power—KW input

NOTES:

① When the entering air dry bulb is other than 80°F [27°C], adjust the sensible capacity from the table by adding $[1.10 \times \text{CFM} \times (1 - \text{DR}) \times (\text{dbE} - 80)]$.

HEATING PERFORMANCE DATA—RQPL-B024

		ENTERING INDOOR AIR @ 80°F [26.7°C] dbE ①									
		60°F [15.5°C]			70°F [21.1°C]			80°F [26.7°C]			
		CFM [L/s]	940 [444]	850 [401]	760 [359]	940 [444]	850 [401]	760 [359]	940 [444]	850 [401]	760 [359]
OUTDOOR DRY BULB TEMPERATURE °F [°C]	0 [-17.8]	Total BTUH [kW] Power	8.9 [2.61] 1.4	8.8 [2.58] 1.4	8.7 [2.55] 1.4	8.0 [2.34] 1.6	7.9 [2.32] 1.6	7.9 [2.32] 1.6	6.5 [1.90] 1.8	6.5 [1.90] 1.8	6.5 [1.90] 1.9
	5 [-15]	Total BTUH [kW] Power	10.5 [3.08] 1.4	10.4 [3.05] 1.4	10.4 [3.05] 1.5	9.6 [2.81] 1.6	9.6 [2.81] 1.6	9.5 [2.78] 1.6	8.2 [2.40] 1.8	8.1 [2.37] 1.9	8.1 [2.37] 1.9
	10 [-12.2]	Total BTUH [kW] Power	12.1 [3.55] 1.4	12.1 [3.55] 1.5	12.0 [3.52] 1.5	11.3 [3.31] 1.6	11.2 [3.28] 1.6	11.1 [3.25] 1.7	9.8 [2.87] 1.9	9.8 [2.87] 1.9	9.7 [2.84] 1.9
	15 [-9.4]	Total BTUH [kW] Power	13.8 [4.04] 1.5	13.7 [4.02] 1.5	13.6 [3.99] 1.5	12.9 [3.78] 1.6	12.8 [3.75] 1.7	12.7 [3.72] 1.7	11.5 [3.37] 1.9	11.4 [3.34] 1.9	11.3 [3.31] 1.9
	20 [-6.7]	Total BTUH [kW] Power	15.4 [4.51] 1.5	15.3 [4.48] 1.5	15.2 [4.45] 1.5	14.5 [4.25] 1.7	14.4 [4.22] 1.7	14.3 [4.19] 1.7	13.1 [3.84] 1.9	13.0 [3.81] 1.9	12.9 [3.78] 1.9
	25 [-3.9]	Total BTUH [kW] Power	17.1 [5.01] 1.5	16.9 [4.95] 1.5	16.8 [4.92] 1.5	16.2 [4.75] 1.7	16.1 [4.72] 1.7	15.9 [4.66] 1.7	14.7 [4.31] 1.9	14.6 [4.28] 1.9	14.5 [4.25] 2.0
	30 [-1.1]	Total BTUH [kW] Power	18.7 [5.48] 1.5	18.6 [5.45] 1.5	18.4 [5.39] 1.6	17.8 [5.22] 1.7	17.7 [5.19] 1.7	17.6 [5.16] 1.7	16.4 [4.81] 1.9	16.3 [4.78] 2.0	16.1 [4.72] 2.0
	35 [1.7]	Total BTUH [kW] Power	20.3 [5.95] 1.5	20.2 [5.92] 1.6	20.0 [5.86] 1.6	19.4 [5.69] 1.7	19.3 [5.66] 1.7	19.2 [5.63] 1.8	18.0 [5.28] 2.0	17.9 [5.25] 2.0	17.8 [5.22] 2.0
	40 [4.4]	Total BTUH [kW] Power	22.0 [6.45] 1.6	21.8 [6.39] 1.6	21.7 [6.36] 1.6	21.1 [6.18] 1.7	20.9 [6.13] 1.8	20.8 [6.10] 1.8	19.6 [5.74] 2.0	19.5 [5.71] 2.0	19.4 [5.69] 2.0
	45 [7.2]	Total BTUH [kW] Power	23.6 [6.92] 1.6	23.4 [6.86] 1.6	23.3 [6.83] 1.6	22.7 [6.65] 1.8	22.6 [6.62] 1.8	22.4 [6.56] 1.8	21.3 [6.24] 2.0	21.1 [6.18] 2.0	21.0 [6.15] 2.1
50 [10]	Total BTUH [kW] Power	25.2 [7.39] 1.6	25.1 [7.36] 1.6	24.9 [7.30] 1.6	24.4 [7.15] 1.8	24.2 [7.09] 1.8	24.0 [7.03] 1.8	22.9 [6.71] 2.0	22.8 [6.68] 2.0	22.6 [6.62] 2.1	

IDB—Indoor air dry bulb

[] Designates Metric Conversions



SYSTEMS PERFORMANCE—RQPL-B SERIES

COOLING PERFORMANCE DATA—RQPL-B030

		ENTERING INDOOR AIR @ 80°F [26.7°C] dbE ①									
		71°F [21.7°C]			67°F [19.4°C]			63°F [17.2°C]			
wbE		1160 [547]	1050 [496]	940 [444]	1160 [547]	1050 [496]	940 [444]	1160 [547]	1050 [496]	940 [444]	
CFM [L/s]		1160 [547]	1050 [496]	940 [444]	1160 [547]	1050 [496]	940 [444]	1160 [547]	1050 [496]	940 [444]	
DR ①		.15	.13	.11	.15	.13	.11	.15	.13	.11	
OUTDOOR DRY BULB TEMPERATURE °F	75 [23.9]	Total BTUH [kW] Sens BTUH [kW] Power	36.9 [10.81] 23.7 [6.95] 1.9	36.2 [10.61] 22.6 [6.62] 1.9	35.5 [10.40] 21.5 [6.30] 1.9	34.9 [10.23] 26.9 [7.88] 1.9	34.2 [10.02] 25.7 [7.53] 1.9	33.6 [9.85] 24.5 [7.18] 1.9	33.5 [9.82] 28.4 [8.32] 1.9	32.9 [9.64] 27.1 [7.94] 1.9	32.3 [9.47] 25.8 [7.56] 1.9
	80 [26.7]	Total BTUH [kW] Sens BTUH [kW] Power	35.7 [10.46] 23.1 [6.77] 2.0	35.1 [10.29] 22.0 [6.45] 2.0	34.4 [10.08] 21.0 [6.15] 2.0	33.7 [9.88] 26.3 [7.71] 2.0	33.1 [9.70] 25.2 [7.39] 2.0	32.5 [9.52] 24.0 [7.03] 2.0	32.3 [9.47] 27.8 [8.15] 2.0	31.8 [9.32] 26.5 [7.77] 2.0	31.2 [9.14] 25.3 [7.41] 2.0
	85 [29.4]	Total BTUH [kW] Sens BTUH [kW] Power	34.6 [10.14] 22.5 [6.59] 2.1	33.9 [9.94] 21.5 [6.30] 2.1	33.3 [9.76] 20.5 [6.01] 2.1	32.6 [9.55] 25.8 [7.56] 2.1	32.0 [9.38] 24.6 [7.21] 2.1	31.4 [9.20] 23.5 [6.89] 2.1	31.2 [9.14] 27.2 [7.97] 2.1	30.6 [8.97] 26.0 [7.62] 2.1	30.1 [8.82] 24.8 [7.27] 2.1
	90 [32.2]	Total BTUH [kW] Sens BTUH [kW] Power	33.4 [9.79] 21.9 [6.42] 2.2	32.8 [9.61] 20.9 [6.13] 2.2	32.2 [9.44] 20.0 [5.86] 2.2	31.4 [9.20] 25.2 [7.39] 2.2	30.9 [9.06] 24.1 [7.06] 2.2	30.3 [8.88] 23.0 [6.74] 2.2	30.1 [8.82] 26.6 [7.80] 2.2	29.5 [8.65] 25.4 [7.44] 2.2	29.0 [8.50] 24.3 [7.12] 2.2
	95 [35]	Total BTUH [kW] Sens BTUH [kW] Power	32.3 [9.47] 21.4 [6.27] 2.3	31.7 [9.29] 20.4 [5.98] 2.3	31.1 [9.11] 19.5 [5.71] 2.3	30.3 [8.88] 24.7 [7.24] 2.3	29.8 [8.73] 23.6 [6.92] 2.3	29.2 [8.56] 22.5 [6.59] 2.2	28.9 [8.47] 26.1 [7.65] 2.3	28.4 [8.32] 24.9 [7.30] 2.3	27.9 [8.18] 23.8 [6.98] 2.3
	100 [37.8]	Total BTUH [kW] Sens BTUH [kW] Power	31.1 [9.11] 20.8 [6.10] 2.4	30.6 [8.97] 19.9 [5.83] 2.4	30.0 [8.79] 19.0 [5.57] 2.4	29.1 [8.53] 24.1 [7.06] 2.4	28.6 [8.38] 23.0 [6.74] 2.4	28.1 [8.24] 22.0 [6.45] 2.3	27.8 [8.15] 25.5 [7.47] 2.4	27.3 [8.00] 24.4 [7.15] 2.4	26.8 [7.85] 23.3 [6.83] 2.4
	105 [40.6]	Total BTUH [kW] Sens BTUH [kW] Power	30.0 [8.79] 20.3 [5.95] 2.5	29.4 [8.62] 19.4 [5.69] 2.5	28.9 [8.47] 18.5 [5.42] 2.5	28.0 [8.21] 23.6 [6.92] 2.5	27.5 [8.06] 22.5 [6.59] 2.5	27.0 [7.91] 21.5 [6.30] 2.4	26.6 [7.80] 25.0 [7.33] 2.5	26.1 [7.65] 23.9 [7.00] 2.5	25.6 [7.50] 22.8 [6.68] 2.5
	110 [43.3]	Total BTUH [kW] Sens BTUH [kW] Power	28.7 [8.41] 19.7 [5.77] 2.6	28.2 [8.26] 18.8 [5.51] 2.6	27.7 [8.12] 18.0 [5.28] 2.6	26.7 [7.83] 23.0 [6.74] 2.6	26.2 [7.68] 22.0 [6.45] 2.6	25.8 [7.56] 21.0 [6.15] 2.5	25.4 [7.44] 24.4 [7.15] 2.6	24.9 [7.30] 23.4 [6.86] 2.6	24.5 [7.18] 22.3 [6.54] 2.6
	115 [46.1]	Total BTUH [kW] Sens BTUH [kW] Power	27.4 [8.03] 19.2 [5.63] 2.7	26.9 [7.88] 18.3 [5.36] 2.7	26.4 [7.74] 17.5 [5.13] 2.7	25.4 [7.44] 22.5 [6.59] 2.7	25.0 [7.33] 21.5 [6.30] 2.6	24.5 [7.18] 20.5 [6.01] 2.6	24.1 [7.06] 23.9 [7.00] 2.7	23.6 [6.92] 22.8 [6.68] 2.7	23.2 [6.80] 21.8 [6.39] 2.7

DR —Depression ratio
dbE—Entering air dry bulb
wbE—Entering air wet bulb

Total —Total capacity x 1000 BTUH
Sens —Sensible capacity x 1000 BTUH
Power—KW input

NOTES:

① When the entering air dry bulb is other than 80°F [27°C], adjust the sensible capacity from the table by adding $[1.10 \times \text{CFM} \times (1 - \text{DR}) \times (\text{dbE} - 80)]$.

HEATING PERFORMANCE DATA—RQPL-B030

		60°F [15.5°C]			70°F [21.1°C]			80°F [26.7°C]			
IDB		1160 [547]	1050 [496]	940 [444]	1160 [547]	1050 [496]	940 [444]	1160 [547]	1050 [496]	940 [444]	
CFM [L/s]		1160 [547]	1050 [496]	940 [444]	1160 [547]	1050 [496]	940 [444]	1160 [547]	1050 [496]	940 [444]	
OUTDOOR DRY BULB TEMPERATURE °F	0 [-17.8]	Total BTUH [kW] Power	9.5 [2.78] 1.6	9.5 [2.78] 1.6	9.4 [2.75] 1.6	8.0 [2.34] 1.8	7.9 [2.32] 1.8	7.9 [2.32] 1.8	6.6 [1.93] 2.0	6.5 [1.90] 2.0	6.5 [1.90] 2.1
	5 [-15]	Total BTUH [kW] Power	11.5 [3.37] 1.6	11.4 [3.34] 1.6	11.3 [3.31] 1.6	19.9 [2.90] 1.8	19.8 [2.87] 1.8	19.8 [2.87] 1.9	18.5 [2.49] 2.0	18.4 [2.46] 2.1	18.4 [2.46] 2.1
	10 [-12.2]	Total BTUH [kW] Power	13.4 [3.93] 1.6	13.3 [3.90] 1.7	13.2 [3.87] 1.7	11.8 [3.46] 1.9	11.8 [3.46] 1.9	11.7 [3.43] 1.9	10.4 [3.05] 2.1	10.3 [3.02] 2.1	10.3 [3.02] 2.1
	15 [-9.4]	Total BTUH [kW] Power	15.3 [4.48] 1.7	15.2 [4.45] 1.7	15.1 [4.43] 1.7	13.8 [4.04] 1.9	13.7 [4.02] 1.9	13.6 [3.99] 1.9	12.3 [3.60] 2.1	12.3 [3.60] 2.1	12.2 [3.58] 2.2
	20 [-6.7]	Total BTUH [kW] Power	17.2 [5.04] 1.7	17.1 [5.01] 1.7	17.0 [4.98] 1.7	15.7 [4.60] 1.9	15.6 [4.57] 1.9	15.5 [4.54] 2.0	14.3 [4.19] 2.1	14.2 [4.16] 2.2	14.1 [4.13] 2.2
	25 [-3.9]	Total BTUH [kW] Power	19.2 [5.63] 1.7	19.0 [5.57] 1.8	18.9 [5.54] 1.8	17.6 [5.16] 1.9	17.5 [5.13] 2.0	17.4 [5.10] 2.0	16.2 [4.75] 2.2	16.1 [4.72] 2.2	16.0 [4.69] 2.2
	30 [-1.1]	Total BTUH [kW] Power	21.1 [6.18] 1.8	20.9 [6.13] 1.8	20.8 [6.10] 1.8	19.5 [5.71] 2.0	19.4 [5.69] 2.0	19.3 [5.66] 2.0	18.1 [5.30] 2.2	18.0 [5.28] 2.2	17.9 [5.25] 2.3
	35 [1.7]	Total BTUH [kW] Power	23.0 [6.74] 1.8	22.8 [6.68] 1.8	22.7 [6.65] 1.8	21.5 [6.30] 2.0	21.3 [6.24] 2.0	21.2 [6.21] 2.1	20.0 [5.86] 2.2	19.9 [5.83] 2.3	19.7 [5.77] 2.3
	40 [4.4]	Total BTUH [kW] Power	24.9 [7.30] 1.8	24.8 [7.27] 1.8	24.6 [7.21] 1.9	23.4 [6.86] 2.0	23.2 [6.80] 2.1	23.0 [6.74] 2.1	22.0 [6.45] 2.3	21.8 [6.39] 2.3	21.6 [6.33] 2.3
	45 [7.2]	Total BTUH [kW] Power	26.9 [7.88] 1.9	26.7 [7.83] 1.9	26.5 [7.77] 1.9	25.3 [7.41] 2.1	25.1 [7.36] 2.1	24.9 [7.30] 2.1	23.9 [7.00] 2.3	23.7 [6.95] 2.3	23.5 [6.89] 2.4
50 [10]	Total BTUH [kW] Power	28.8 [8.44] 1.9	28.6 [8.38] 1.9	28.4 [8.32] 1.9	27.2 [7.97] 2.1	27.0 [7.91] 2.1	26.8 [7.85] 2.2	25.8 [7.56] 2.3	25.6 [7.50] 2.4	25.4 [7.44] 2.4	

IDB—Indoor air dry bulb

[] Designates Metric Conversions

SYSTEMS PERFORMANCE—RQPL-B SERIES



COOLING PERFORMANCE DATA—RQPL-B036

		ENTERING INDOOR AIR @ 80°F [26.7°C] dbE ①									
		71°F [21.7°C]			67°F [19.4°C]			63°F [17.2°C]			
		CFM [L/s]	1380 [651]	1250 [590]	1120 [528]	1380 [651]	1250 [590]	1120 [528]	1380 [651]	1250 [590]	1120 [528]
		DR ①	.21	.19	.17	.21	.19	.17	.21	.19	.17
OUTDOOR DRY BULB TEMPERATURE °F [°C]	75 [23.9]	Total BTUH [kW] Sens BTUH [kW] Power	45.0 [13.19] 27.7 [8.12] 2.3	44.2 [12.95] 26.5 [7.77] 2.2	43.4 [12.72] 25.3 [7.41] 2.2	42.9 [12.57] 31.8 [9.32] 2.2	42.2 [12.37] 30.4 [8.91] 2.2	41.4 [12.13] 28.9 [8.47] 2.2	41.8 [12.25] 34.2 [10.02] 2.2	41.0 [12.02] 32.6 [9.55] 2.2	40.3 [11.81] 31.1 [9.11] 2.2
	80 [26.7]	Total BTUH [kW] Sens BTUH [kW] Power	43.9 [12.87] 27.1 [7.94] 2.4	43.1 [12.63] 25.9 [7.59] 2.4	42.3 [12.40] 24.7 [7.24] 2.4	41.8 [12.25] 31.2 [9.14] 2.4	41.1 [12.05] 29.8 [8.73] 2.4	40.3 [11.81] 28.4 [8.32] 2.3	40.7 [11.93] 33.5 [9.82] 2.4	39.9 [11.69] 32.0 [9.38] 2.3	39.2 [11.49] 30.5 [8.94] 2.3
	85 [29.4]	Total BTUH [kW] Sens BTUH [kW] Power	42.6 [12.48] 26.5 [7.77] 2.5	41.8 [12.25] 25.3 [7.41] 2.5	41.0 [12.02] 24.1 [7.06] 2.5	40.5 [11.87] 30.5 [8.94] 2.5	39.8 [11.66] 29.1 [8.53] 2.5	39.1 [11.46] 27.8 [8.15] 2.5	39.4 [11.55] 32.9 [9.64] 2.5	38.7 [11.34] 31.4 [9.20] 2.5	37.9 [11.11] 29.9 [8.76] 2.5
	90 [32.2]	Total BTUH [kW] Sens BTUH [kW] Power	41.1 [12.05] 25.7 [7.53] 2.7	40.3 [11.81] 24.6 [7.21] 2.7	39.6 [11.61] 23.5 [6.89] 2.6	39.0 [11.43] 29.8 [8.73] 2.7	38.3 [11.22] 28.5 [8.35] 2.6	37.6 [11.02] 27.1 [7.94] 2.6	37.9 [11.11] 32.2 [9.44] 2.6	37.2 [10.90] 30.7 [9.00] 2.6	36.5 [10.70] 29.3 [8.59] 2.6
	95 [35]	Total BTUH [kW] Sens BTUH [kW] Power	39.5 [11.58] 25.0 [7.33] 2.8	38.8 [11.37] 23.9 [7.00] 2.8	38.1 [11.17] 22.8 [6.68] 2.8	37.4 [10.96] 29.1 [8.53] 2.8	36.8 [10.79] 27.8 [8.15] 2.8	36.1 [10.58] 26.5 [7.77] 2.8	36.3 [10.64] 31.4 [9.20] 2.8	35.6 [10.43] 30.0 [8.79] 2.8	35.0 [10.26] 28.6 [8.38] 2.7
	100 [37.8]	Total BTUH [kW] Sens BTUH [kW] Power	37.8 [11.08] 24.2 [7.09] 3.0	37.1 [10.87] 23.2 [6.80] 2.9	36.5 [10.70] 22.1 [6.48] 2.9	35.8 [10.49] 28.3 [8.29] 2.9	35.1 [10.29] 27.0 [7.91] 2.9	34.5 [10.11] 25.8 [7.56] 2.9	34.6 [10.14] 30.7 [9.00] 2.9	34.0 [9.96] 29.3 [8.59] 2.9	33.4 [9.79] 27.9 [8.18] 2.9
	105 [40.6]	Total BTUH [kW] Sens BTUH [kW] Power	36.1 [10.58] 23.4 [6.86] 3.1	35.5 [10.40] 22.4 [6.56] 3.1	34.8 [10.20] 21.3 [6.24] 3.1	34.1 [9.99] 27.5 [8.06] 3.1	33.5 [9.82] 26.3 [7.71] 3.1	32.8 [9.61] 25.0 [7.33] 3.0	32.9 [9.64] 29.9 [8.76] 3.1	32.3 [9.47] 28.5 [8.35] 3.0	31.7 [9.29] 27.2 [7.97] 3.0
	110 [43.3]	Total BTUH [kW] Sens BTUH [kW] Power	34.4 [10.08] 22.6 [6.62] 3.3	33.8 [9.91] 21.6 [6.33] 3.2	33.2 [9.73] 20.6 [6.04] 3.2	32.4 [9.50] 26.7 [7.83] 3.2	31.8 [9.32] 25.5 [7.47] 3.2	31.2 [9.14] 24.3 [7.12] 3.2	31.2 [9.14] 29.0 [8.50] 3.2	30.7 [9.00] 27.7 [8.12] 3.2	30.1 [8.82] 26.4 [7.74] 3.2
	115 [46.1]	Total BTUH [kW] Sens BTUH [kW] Power	32.8 [9.61] 21.8 [6.39] 3.4	32.2 [9.44] 20.8 [6.10] 3.4	31.7 [9.29] 19.8 [5.80] 3.3	30.8 [9.03] 25.8 [7.56] 3.4	30.2 [8.85] 24.7 [7.24] 3.3	29.7 [8.70] 23.5 [6.89] 3.3	29.6 [8.67] 28.2 [8.26] 3.4	29.1 [8.53] 26.9 [7.88] 3.3	28.6 [8.38] 25.7 [7.53] 3.3

DR —Depression ratio
dbE —Entering air dry bulb
wbE —Entering air wet bulb

Total —Total capacity x 1000 BTUH
Sens —Sensible capacity x 1000 BTUH
Power—KW input

NOTES:

① When the entering air dry bulb is other than 80°F [27°C], adjust the sensible capacity from the table by adding $[1.10 \times \text{CFM} \times (1 - \text{DR}) \times (\text{dbE} - 80)]$.

HEATING PERFORMANCE DATA—RQPL-B036

		ENTERING INDOOR AIR @ 80°F [26.7°C] dbE ①									
		60°F [15.5°C]			70°F [21.1°C]			80°F [26.7°C]			
		CFM [L/s]	1380 [651]	1250 [590]	1120 [528]	1380 [651]	1250 [590]	1120 [528]	1380 [651]	1250 [590]	1120 [528]
OUTDOOR DRY BULB TEMPERATURE °F [°C]	0 [-17.8]	Total BTUH [kW] Power	11.7 [3.43] 1.8	11.6 [3.40] 1.9	11.5 [3.37] 1.9	9.6 [2.81] 2.1	9.6 [2.81] 2.1	9.5 [2.78] 2.1	8.3 [2.43] 2.4	8.2 [2.40] 2.4	8.1 [2.37] 2.4
	5 [-15]	Total BTUH [kW] Power	14.1 [4.13] 1.9	14.0 [4.10] 1.9	13.9 [4.07] 1.9	12.1 [3.55] 2.1	12.0 [3.52] 2.2	11.9 [3.49] 2.2	10.7 [3.14] 2.4	10.6 [3.11] 2.5	10.6 [3.11] 2.5
	10 [-12.2]	Total BTUH [kW] Power	16.6 [4.86] 1.9	16.5 [4.84] 1.9	16.3 [4.78] 2.0	14.5 [4.25] 2.2	14.4 [4.22] 2.2	14.3 [4.19] 2.2	13.2 [3.87] 2.5	13.1 [3.84] 2.5	13.0 [3.81] 2.5
	15 [-9.4]	Total BTUH [kW] Power	19.0 [5.57] 2.0	18.9 [5.54] 2.0	18.8 [5.51] 2.0	17.0 [4.98] 2.2	16.9 [4.95] 2.2	16.7 [4.89] 2.3	15.6 [4.57] 2.5	15.5 [4.54] 2.5	15.4 [4.51] 2.6
	20 [-6.7]	Total BTUH [kW] Power	21.5 [6.30] 2.0	21.3 [6.24] 2.0	21.2 [6.21] 2.1	19.4 [5.69] 2.3	19.3 [5.66] 2.3	19.2 [5.63] 2.3	18.1 [5.30] 2.5	17.9 [5.25] 2.6	17.8 [5.22] 2.6
	25 [-3.9]	Total BTUH [kW] Power	23.9 [7.00] 2.0	23.8 [6.98] 2.1	23.6 [6.92] 2.1	21.9 [6.42] 2.3	21.7 [6.36] 2.3	21.6 [6.33] 2.4	20.5 [6.01] 2.6	20.4 [5.98] 2.6	20.2 [5.92] 2.7
	30 [-1.1]	Total BTUH [kW] Power	26.4 [7.74] 2.1	26.2 [7.68] 2.1	26.0 [7.62] 2.1	24.3 [7.12] 2.3	24.2 [7.09] 2.4	24.0 [7.03] 2.4	23.0 [6.74] 2.6	22.8 [6.68] 2.7	22.6 [6.62] 2.7
	35 [1.7]	Total BTUH [kW] Power	28.8 [8.44] 2.1	28.6 [8.38] 2.1	28.4 [8.32] 2.2	26.8 [7.85] 2.4	26.6 [7.80] 2.4	26.4 [7.74] 2.4	25.4 [7.44] 2.7	25.2 [7.39] 2.7	25.1 [7.36] 2.7
	40 [4.4]	Total BTUH [kW] Power	31.3 [9.17] 2.2	31.1 [9.11] 2.2	30.8 [9.03] 2.2	29.2 [8.56] 2.4	29.0 [8.50] 2.4	28.8 [8.44] 2.5	27.9 [8.18] 2.7	27.7 [8.12] 2.7	27.5 [8.06] 2.8
	45 [7.2]	Total BTUH [kW] Power	33.7 [9.88] 2.2	33.5 [9.82] 2.2	33.3 [9.76] 2.3	31.7 [9.29] 2.5	31.5 [9.23] 2.5	31.2 [9.14] 2.5	30.3 [8.88] 2.8	30.1 [8.82] 2.8	29.9 [8.76] 2.8
50 [10]	Total BTUH [kW] Power	36.2 [10.61] 2.2	35.9 [10.52] 2.3	35.7 [10.46] 2.3	34.1 [9.99] 2.5	33.9 [9.94] 2.5	33.7 [9.88] 2.6	32.8 [9.61] 2.8	32.5 [9.52] 2.8	32.3 [9.47] 2.9	

IDB—Indoor air dry bulb

[] Designates Metric Conversions



SYSTEMS PERFORMANCE—RQPL-B SERIES

COOLING PERFORMANCE DATA—RQPL-B042

		ENTERING INDOOR AIR @ 80°F [26.7°C] dbE ①									
		wbE	71°F [21.7°C]			67°F [19.4°C]			63°F [17.2°C]		
		CFM [L/s]	1540 [727]	1400 [661]	1260 [595]	1540 [727]	1400 [661]	1260 [595]	1540 [727]	1400 [661]	1260 [595]
		DR ①	.17	.15	.14	.17	.15	.14	.17	.15	.14
OUTDOOR DRY BULB TEMPERATURE °F [°C]	75 [23.9]	Total BTUH [kW]	53.9 [5.80]	52.9 [15.50]	51.9 [15.21]	50.9 [14.92]	50.0 [14.65]	49.1 [14.39]	48.1 [14.10]	47.3 [13.86]	46.4 [13.60]
		Sens BTUH [kW]	32.2 [9.44]	30.7 [9.00]	29.3 [8.59]	27.1 [7.94]	26.4 [7.74]	25.7 [7.53]	24.9 [7.30]	24.1 [7.06]	23.1 [6.77]
		Power	2.9	2.9	2.9	3.3	3.3	3.3	3.9	3.9	4.0
	80 [26.7]	Total BTUH [kW]	52.0 [15.24]	51.0 [14.95]	50.1 [14.68]	49.0 [14.36]	48.1 [14.10]	47.2 [13.83]	46.2 [13.54]	45.4 [13.31]	44.6 [13.07]
		Sens BTUH [kW]	31.3 [9.17]	29.9 [8.76]	28.5 [8.35]	27.1 [7.94]	26.4 [7.74]	25.7 [7.53]	24.9 [7.30]	24.1 [7.06]	23.1 [6.77]
		Power	3.1	3.1	3.1	3.4	3.4	3.4	3.9	3.9	4.0
	85 [29.4]	Total BTUH [kW]	50.3 [14.74]	49.4 [14.48]	48.5 [14.21]	47.3 [13.86]	46.5 [13.63]	45.6 [13.36]	44.6 [13.07]	43.8 [12.84]	43.0 [12.60]
		Sens BTUH [kW]	30.5 [8.94]	29.2 [8.56]	27.8 [8.15]	26.4 [7.74]	25.7 [7.53]	24.9 [7.30]	24.1 [7.06]	23.1 [6.77]	22.4 [6.50]
		Power	3.3	3.2	3.2	3.6	3.6	3.6	4.1	4.1	4.2
	90 [32.2]	Total BTUH [kW]	48.7 [14.27]	47.9 [14.04]	47.0 [13.77]	45.8 [13.42]	44.9 [13.16]	44.1 [12.92]	43.0 [12.60]	42.2 [12.37]	41.5 [12.16]
Sens BTUH [kW]		29.8 [8.73]	28.4 [8.32]	27.1 [7.94]	25.7 [7.53]	24.9 [7.30]	24.1 [7.06]	23.1 [6.77]	22.4 [6.50]	21.7 [6.27]	
Power		3.4	3.4	3.4	3.8	3.8	3.8	4.3	4.3	4.4	
95 [35]	Total BTUH [kW]	47.2 [13.83]	46.4 [13.60]	45.5 [13.33]	44.2 [12.95]	43.4 [12.72]	42.7 [12.51]	41.5 [12.16]	40.7 [11.93]	40.0 [11.72]	
	Sens BTUH [kW]	29.0 [8.50]	27.7 [8.12]	26.4 [7.74]	24.9 [7.30]	24.1 [7.06]	23.1 [6.77]	22.4 [6.50]	21.7 [6.27]	21.0 [6.04]	
	Power	3.6	3.6	3.5	3.9	3.9	3.9	4.4	4.4	4.5	
100 [37.8]	Total BTUH [kW]	45.6 [13.36]	44.8 [13.13]	44.0 [12.90]	42.6 [12.48]	41.9 [12.28]	41.1 [12.05]	39.9 [11.69]	39.2 [11.49]	38.5 [11.28]	
	Sens BTUH [kW]	28.2 [8.26]	26.9 [7.88]	25.7 [7.53]	24.1 [7.06]	23.1 [6.77]	22.4 [6.50]	21.7 [6.27]	21.0 [6.04]	20.3 [5.81]	
	Power	3.8	3.7	3.7	4.1	4.1	4.1	4.6	4.6	4.7	
105 [40.6]	Total BTUH [kW]	43.8 [12.84]	43.0 [12.60]	42.3 [12.40]	40.8 [11.96]	40.1 [11.75]	39.4 [11.55]	38.1 [11.17]	37.4 [10.96]	36.7 [10.76]	
	Sens BTUH [kW]	27.4 [8.03]	26.1 [7.65]	24.9 [7.30]	23.1 [6.77]	22.4 [6.50]	21.7 [6.27]	21.0 [6.04]	20.3 [5.81]	19.6 [5.60]	
	Power	3.9	3.9	3.9	4.3	4.3	4.3	4.8	4.8	4.9	
110 [43.3]	Total BTUH [kW]	41.7 [12.22]	41.0 [12.02]	40.2 [11.78]	38.8 [11.37]	38.1 [11.17]	37.4 [10.96]	36.0 [10.55]	35.4 [10.37]	34.7 [10.17]	
	Sens BTUH [kW]	26.4 [7.74]	25.2 [7.39]	24.1 [7.06]	22.4 [6.50]	21.7 [6.27]	21.0 [6.04]	20.3 [5.81]	19.6 [5.60]	18.9 [5.40]	
	Power	4.1	4.1	4.0	4.4	4.4	4.4	4.9	4.9	5.0	
115 [46.1]	Total BTUH [kW]	39.3 [11.52]	38.6 [11.31]	37.9 [11.11]	36.3 [10.64]	35.6 [10.43]	35.0 [10.26]	33.5 [9.82]	32.9 [9.64]	32.3 [9.47]	
	Sens BTUH [kW]	25.4 [7.44]	24.2 [7.09]	23.1 [6.77]	21.7 [6.27]	21.0 [6.04]	20.3 [5.81]	19.6 [5.60]	18.9 [5.40]	18.2 [5.20]	
	Power	4.3	4.2	4.2	4.6	4.6	4.6	5.1	5.1	5.2	

DR —Depression ratio
dbE—Entering air dry bulb
wbE—Entering air wet bulb

Total —Total capacity x 1000 BTUH
Sens —Sensible capacity x 1000 BTUH
Power—KW input

NOTES:

① When the entering air dry bulb is other than 80°F [27°C], adjust the sensible capacity from the table by adding $[1.10 \times \text{CFM} \times (1 - \text{DR}) \times (\text{dbE} - 80)]$.

HEATING PERFORMANCE DATA—RQPL-B042

		IDB	60°F [15.5°C]			70°F [21.1°C]			80°F [26.7°C]		
		CFM [L/s]	1540 [727]	1400 [661]	1260 [595]	1540 [727]	1400 [661]	1260 [595]	1540 [727]	1400 [661]	1260 [595]
OUTDOOR DRY BULB TEMPERATURE °F [°C]	0 [-17.8]	Total BTUH [kW]	13.9 [4.07]	13.8 [4.04]	13.7 [4.02]	12.9 [3.78]	12.8 [3.75]	12.8 [3.75]	11.2 [3.28]	11.1 [3.25]	11.1 [3.25]
		Power	2.6	2.6	2.6	3.0	3.0	3.1	3.3	3.4	3.4
	5 [-15]	Total BTUH [kW]	16.9 [4.95]	16.8 [4.92]	16.7 [4.89]	16.0 [4.69]	15.8 [4.63]	15.7 [4.60]	14.2 [4.16]	14.1 [4.13]	14.0 [4.10]
		Power	2.6	2.6	2.7	3.0	3.1	3.1	3.4	3.4	3.5
	10 [-12.2]	Total BTUH [kW]	20.0 [5.86]	19.8 [5.80]	19.7 [5.77]	19.0 [5.57]	18.8 [5.51]	18.7 [5.48]	17.3 [5.07]	17.1 [5.01]	17.0 [4.98]
		Power	2.6	2.7	2.7	3.1	3.1	3.1	3.4	3.5	3.5
	15 [-9.4]	Total BTUH [kW]	23.0 [6.74]	22.8 [6.68]	22.6 [6.62]	22.0 [6.45]	21.8 [6.39]	21.7 [6.36]	20.3 [5.95]	20.1 [5.89]	20.0 [5.86]
		Power	2.7	2.7	2.7	3.1	3.1	3.2	3.5	3.5	3.5
	20 [-6.7]	Total BTUH [kW]	26.0 [7.62]	25.8 [7.56]	25.6 [7.50]	25.0 [7.33]	24.8 [7.27]	24.7 [7.24]	23.3 [6.83]	23.1 [6.77]	23.0 [6.74]
		Power	2.7	2.7	2.8	3.1	3.2	3.2	3.5	3.5	3.6
25 [-3.9]	Total BTUH [kW]	29.0 [8.50]	28.8 [8.44]	28.6 [8.38]	28.0 [8.21]	27.8 [8.15]	27.6 [8.09]	26.3 [7.71]	26.1 [7.65]	25.9 [7.59]	
	Power	2.8	2.8	2.8	3.2	3.2	3.3	3.5	3.6	3.6	
30 [-1.1]	Total BTUH [kW]	32.0 [9.38]	31.8 [9.32]	31.6 [9.26]	31.1 [9.11]	30.8 [9.03]	30.6 [8.97]	29.3 [8.59]	29.1 [8.53]	28.9 [8.47]	
	Power	2.8	2.8	2.9	3.2	3.2	3.3	3.6	3.6	3.7	
35 [1.7]	Total BTUH [kW]	35.1 [10.29]	34.8 [10.20]	34.6 [10.14]	34.1 [9.99]	33.8 [9.91]	33.6 [9.85]	32.4 [9.50]	32.1 [9.41]	31.9 [9.35]	
	Power	2.8	2.9	2.9	3.2	3.3	3.3	3.6	3.6	3.7	
40 [4.4]	Total BTUH [kW]	38.1 [11.17]	37.8 [11.08]	37.5 [10.99]	37.1 [10.87]	36.8 [10.79]	36.6 [10.73]	35.4 [10.37]	35.1 [10.29]	34.9 [10.23]	
	Power	2.9	2.9	2.9	3.3	3.3	3.4	3.6	3.7	3.7	
45 [7.2]	Total BTUH [kW]	41.1 [12.05]	40.8 [11.96]	40.5 [11.87]	40.1 [11.75]	39.8 [11.66]	39.5 [11.58]	38.4 [11.25]	38.1 [11.17]	37.9 [11.11]	
	Power	2.9	2.9	3.0	3.3	3.4	3.4	3.7	3.7	3.8	
50 [10]	Total BTUH [kW]	44.1 [12.92]	43.8 [12.84]	43.5 [12.75]	43.1 [12.63]	42.8 [12.54]	42.5 [12.46]	41.4 [12.13]	41.1 [12.05]	40.8 [11.96]	
	Power	2.9	3.0	3.0	3.4	3.4	3.4	3.7	3.8	3.8	

IDB—Indoor air dry bulb

[] Designates Metric Conversions

SYSTEMS PERFORMANCE—RQPL-B SERIES



COOLING PERFORMANCE DATA—RQPL-B048

		ENTERING INDOOR AIR @ 80°F [26.7°C] dbE ①									
		wbE	71°F [21.7°C]			67°F [19.4°C]			63°F [17.2°C]		
			CFM [L/s]	1760 [831]	1600 [755]	1440 [680]	1760 [831]	1600 [755]	1440 [680]	1760 [831]	1600 [755]
DR ①			.15	.13	.11	.15	.13	.11	.15	.13	.11
OUTDOOR DRY BULB TEMPERATURE °F [°C]	75 [23.9]	Total BTUH [kW] Sens BTUH [kW] Power	60.4 [17.70] 37.4 [10.96] 3.2	59.3 [17.38] 35.7 [10.46] 3.1	58.3 [17.09] 34.1 [9.99] 3.1	57.1 [16.73] 42.7 [12.51] 3.1	56.1 [16.44] 40.8 [11.96] 3.1	55.0 [16.12] 38.9 [11.40] 3.1	54.5 [15.97] 45.0 [13.19] 3.1	53.5 [15.68] 43.0 [12.60] 3.1	52.5 [15.39] 41.0 [12.02] 3.1
	80 [26.7]	Total BTUH [kW] Sens BTUH [kW] Power	58.8 [17.23] 36.6 [10.73] 3.4	57.8 [16.94] 35.0 [10.26] 3.3	56.7 [16.62] 33.3 [9.76] 3.3	55.5 [16.27] 41.9 [12.28] 3.3	54.5 [15.97] 40.0 [11.72] 3.3	53.5 [15.68] 38.2 [11.20] 3.3	52.9 [15.50] 44.2 [12.95] 3.3	51.9 [15.21] 42.2 [12.37] 3.3	51.0 [14.95] 40.3 [11.81] 3.2
	85 [29.4]	Total BTUH [kW] Sens BTUH [kW] Power	57.0 [16.71] 35.7 [10.46] 3.5	56.0 [16.41] 34.1 [9.99] 3.5	55.0 [16.12] 32.5 [9.52] 3.5	53.7 [15.74] 41.0 [12.02] 3.5	52.7 [15.44] 39.2 [11.49] 3.5	51.8 [15.18] 37.3 [10.93] 3.5	51.1 [14.98] 43.3 [12.69] 3.5	50.2 [14.71] 41.4 [12.13] 3.5	49.3 [14.45] 39.4 [11.55] 3.4
	90 [32.2]	Total BTUH [kW] Sens BTUH [kW] Power	55.1 [16.15] 34.8 [10.20] 3.7	54.1 [15.86] 33.2 [9.73] 3.7	53.1 [15.56] 31.7 [9.29] 3.7	51.7 [15.15] 40.1 [11.75] 3.7	50.8 [14.89] 38.3 [11.22] 3.7	49.9 [14.62] 36.5 [10.70] 3.6	49.1 [14.39] 42.4 [12.43] 3.7	48.3 [14.16] 40.5 [11.87] 3.6	47.4 [13.89] 38.6 [11.31] 3.6
	95 [35]	Total BTUH [kW] Sens BTUH [kW] Power	53.1 [15.56] 33.8 [9.91] 3.9	52.1 [15.27] 32.3 [9.47] 3.9	51.2 [15.01] 30.8 [9.03] 3.9	49.8 [14.59] 39.1 [11.46] 3.9	48.9 [14.33] 37.4 [10.96] 3.9	48.0 [14.07] 35.6 [10.43] 3.8	47.2 [13.83] 41.4 [12.13] 3.9	46.3 [13.57] 39.6 [11.61] 3.8	45.5 [13.33] 37.7 [11.05] 3.8
	100 [37.8]	Total BTUH [kW] Sens BTUH [kW] Power	51.1 [14.98] 32.9 [9.64] 4.1	50.2 [14.71] 31.4 [9.20] 4.1	49.3 [14.45] 29.9 [8.76] 4.0	47.8 [14.01] 38.2 [11.20] 4.1	46.9 [13.75] 36.5 [10.70] 4.0	46.1 [13.51] 34.8 [10.20] 4.0	45.2 [13.25] 40.5 [11.87] 4.1	44.4 [13.01] 38.7 [11.34] 4.0	43.6 [12.78] 36.9 [10.81] 4.0
	105 [40.6]	Total BTUH [kW] Sens BTUH [kW] Power	49.3 [14.45] 32.0 [9.38] 4.3	48.4 [14.18] 30.6 [8.97] 4.3	47.5 [13.92] 29.2 [8.56] 4.2	46.0 [13.48] 37.3 [10.93] 4.2	45.1 [13.22] 35.7 [10.46] 4.2	44.3 [12.98] 34.0 [9.96] 4.2	43.4 [12.72] 39.6 [11.61] 4.2	42.6 [12.48] 37.9 [11.11] 4.2	41.8 [12.25] 36.1 [10.58] 4.2
	110 [43.3]	Total BTUH [kW] Sens BTUH [kW] Power	47.6 [13.95] 31.3 [9.17] 4.5	46.8 [13.72] 29.9 [8.76] 4.4	45.9 [13.45] 28.5 [8.35] 4.4	44.3 [12.98] 36.6 [10.73] 4.5	43.5 [12.75] 34.9 [10.23] 4.4	42.7 [12.51] 33.3 [9.76] 4.4	41.7 [12.22] 38.9 [11.40] 4.4	41.0 [12.02] 37.1 [10.87] 4.4	40.2 [11.78] 35.4 [10.37] 4.4
	115 [46.1]	Total BTUH [kW] Sens BTUH [kW] Power	46.3 [13.57] 30.7 [9.00] 4.7	45.5 [13.33] 29.3 [8.59] 4.6	44.6 [13.07] 27.9 [8.18] 4.6	43.0 [12.60] 36.0 [10.55] 4.6	42.2 [12.37] 34.4 [10.08] 4.6	41.4 [12.13] 32.8 [9.61] 4.6	40.4 [11.84] 38.3 [11.22] 4.6	39.6 [11.61] 36.6 [10.73] 4.6	38.9 [11.40] 34.8 [10.20] 4.5

DR —Depression ratio
dbE—Entering air dry bulb
wbE—Entering air wet bulb

Total —Total capacity x 1000 BTUH
Sens —Sensible capacity x 1000 BTUH
Power—KW input

NOTES:

① When the entering air dry bulb is other than 80°F [27°C], adjust the sensible capacity from the table by adding $[1.10 \times \text{CFM} \times (1 - \text{DR}) \times (\text{dbE} - 80)]$.

HEATING PERFORMANCE DATA—RQPL-B048

		IDB	60°F [15.5°C]			70°F [21.1°C]			80°F [26.7°C]		
			CFM [L/s]	1760 [831]	1600 [755]	1440 [680]	1760 [831]	1600 [755]	1440 [680]	1760 [831]	1600 [755]
OUTDOOR DRY BULB TEMPERATURE °F [°C]	0 [-17.8]	Total BTUH [kW] Power	16.9 [4.95] 2.6	16.8 [4.92] 2.6	16.7 [4.89] 2.6	15.4 [4.51] 3.0	15.3 [4.48] 3.0	15.2 [4.45] 3.0	14.4 [4.22] 3.4	14.3 [4.19] 3.5	14.2 [4.16] 3.5
	5 [-15]	Total BTUH [kW] Power	20.1 [5.89] 2.6	19.9 [5.83] 2.6	19.8 [5.80] 2.7	18.6 [5.45] 3.0	18.5 [5.42] 3.0	18.3 [5.36] 3.1	17.6 [5.16] 3.5	17.5 [5.13] 3.5	17.3 [5.07] 3.5
	10 [-12.2]	Total BTUH [kW] Power	23.2 [6.80] 2.7	23.1 [6.77] 2.7	22.9 [6.71] 2.7	21.8 [6.39] 3.1	21.6 [6.33] 3.1	21.5 [6.30] 3.1	20.7 [6.07] 3.5	20.6 [6.04] 3.6	20.4 [5.98] 3.6
	15 [-9.4]	Total BTUH [kW] Power	26.4 [7.74] 2.7	26.2 [7.68] 2.8	26.0 [7.62] 2.8	24.9 [7.30] 3.1	24.7 [7.24] 3.2	24.6 [7.21] 3.2	23.9 [7.00] 3.6	23.7 [6.95] 3.6	23.6 [6.92] 3.7
	20 [-6.7]	Total BTUH [kW] Power	29.5 [8.65] 2.8	29.3 [8.59] 2.8	29.1 [8.53] 2.8	28.1 [8.24] 3.2	27.9 [8.18] 3.2	27.7 [8.12] 3.2	27.1 [7.94] 3.6	26.9 [7.88] 3.7	26.7 [7.83] 3.7
	25 [-3.9]	Total BTUH [kW] Power	32.7 [9.58] 2.8	32.5 [9.52] 2.9	32.2 [9.44] 2.9	31.2 [9.14] 3.2	31.0 [9.09] 3.3	30.8 [9.03] 3.3	30.2 [8.85] 3.7	30.0 [8.79] 3.7	29.8 [8.73] 3.8
	30 [-1.1]	Total BTUH [kW] Power	35.9 [10.52] 2.9	35.6 [10.43] 2.9	35.4 [10.37] 2.9	34.4 [10.08] 3.3	34.1 [9.99] 3.3	33.9 [9.94] 3.4	33.4 [9.79] 3.7	33.1 [9.70] 3.8	32.9 [9.64] 3.8
	35 [1.7]	Total BTUH [kW] Power	39.0 [11.43] 2.9	38.7 [11.34] 3.0	38.5 [11.28] 3.0	37.5 [10.99] 3.3	37.3 [10.93] 3.4	37.0 [10.84] 3.4	36.5 [10.70] 3.8	36.3 [10.64] 3.8	36.0 [10.55] 3.9
	40 [4.4]	Total BTUH [kW] Power	42.2 [12.37] 3.0	41.9 [12.28] 3.0	41.6 [12.19] 3.1	40.7 [11.93] 3.4	40.4 [11.84] 3.4	40.1 [11.75] 3.5	39.7 [11.63] 3.8	39.4 [11.55] 3.9	39.1 [11.46] 3.9
	45 [7.2]	Total BTUH [kW] Power	45.3 [13.28] 3.0	45.0 [13.19] 3.1	44.7 [13.10] 3.1	43.9 [12.87] 3.4	43.6 [12.78] 3.5	43.2 [12.66] 3.5	42.8 [12.54] 3.9	42.5 [12.46] 3.9	42.2 [12.37] 4.0
50 [10]	Total BTUH [kW] Power	48.5 [14.21] 3.1	48.1 [14.10] 3.1	47.8 [14.01] 3.2	47.0 [13.77] 3.5	46.7 [13.69] 3.5	46.4 [13.60] 3.6	46.0 [13.48] 3.9	45.7 [13.39] 4.0	45.3 [13.28] 4.0	

IDB—Indoor air dry bulb

[] Designates Metric Conversions



INDOOR AIRFLOW PERFORMANCE—208 VOLTS

Nominal Cooling Capacity Tons [kW]	Motor Speed from Factory	Manufacturer Recommended Air-Flow Range (Min/Max) CFM	Blower Size/ Motor HP [W] & # of Speeds	Motor Speed	External Static Pressure—Inches W.C. [kPa] Side Discharge—Wet Coil							
					0.1 [1.02]	0.2 [1.05]	0.3 [1.07]	0.4 [1.10]	0.5 [1.12]	0.6 [1.15]	0.7 [1.17]	
2.0 [7.03]	High	700 CFM/900 CFM [271/319 L/s]	9x7 Blower 1/4 HP [186] 2 Speed (PSC Motor)	Low	CFM	675 [319]	657 [310]	634 [299]	602 [284]	560 [264]	505 [238]	435 [205]
					RPM	695	785	870	905	940	980	1020
					Watts	221	214	203	191	171	163	149
2.5 [8.79]	Low	875 CFM/1125 CFM [413/531 L/s]	10x9 Blower 1/2 HP [372] 2 Speed (PSC Motor)	High	CFM	898 [424]	861 [406]	822 [388]	777 [367]	721 [340]	651 [307]	562 [265]
					RPM	940	965	995	1020	1045	1070	1090
					Watts	292	278	266	253	239	221	199
3.0 [10.55]	Low	1050 CFM/1350 CFM [496/637 L/s]	10x9 Blower 1/3 HP [248] 1 Speed (PSC Motor)	High	CFM	1076 [508]	1059 [500]	1032 [487]	996 [470]	950 [448]	896 [423]	832 [393]
					RPM	730	775	820	865	905	940	975
					Watts	356	349	341	331	320	305	287
3.5 [12.31]	Low (Tap 1)	1225 CFM/1575 CFM [578/743 L/s]	10x9 Blower 3/4 HP [559] 2 Speed (X13 Motor)	High (Tap 2)	CFM	1222 [577]	1201 [567]	1173 [554]	1137 [537]	1090 [514]	1030 [486]	954 [450]
					RPM	785	805	830	870	905	950	990
					Watts	355	352	346	340	331	320	306
4.0 [14.07]	Low (Tap 1)	1350 CFM/1700 CFM [496/802 L/s]	10x9 Blower 3/4 HP [559] 2 Speed (X13 Motor)	High (Tap 2)	CFM	1455 [687]	1431 [675]	1396 [659]	1360 [642]	1315 [621]	1285 [606]	1241 [586]
					RPM	824	856	889	931	968	1009	1041
					Watts	268	280	288	303	311	325	331
4.0 [14.07]	Low (Tap 1)	1350 CFM/1700 CFM [496/802 L/s]	10x9 Blower 3/4 HP [559] 2 Speed (X13 Motor)	High (Tap 2)	CFM	1559 [736]	1530 [722]	1488 [702]	1454 [686]	1417 [669]	1375 [649]	1336 [631]
					RPM	870	893	932	968	1007	1036	1072
					Watts	321	327	338	351	364	371	381
4.0 [14.07]	Low (Tap 1)	1350 CFM/1700 CFM [496/802 L/s]	10x9 Blower 3/4 HP [559] 2 Speed (X13 Motor)	High (Tap 2)	CFM	1675 [791]	1658 [782]	1610 [760]	1580 [746]	1535 [724]	1491 [704]	1422 [671]
					RPM	923	944	979	1013	1045	1077	1098
					Watts	390	401	412	425	433	440	432
4.0 [14.07]	Low (Tap 1)	1350 CFM/1700 CFM [496/802 L/s]	10x9 Blower 3/4 HP [559] 2 Speed (X13 Motor)	High (Tap 2)	CFM	1770 [835]	1751 [826]	1706 [805]	1672 [789]	1624 [766]	1555 [734]	1463 [690]
					RPM	966	989	1018	1050	1078	1100	1115
					Watts	454	466	473	486	490	481	460

NOTE: Effect of electric heat strip on airflow performance is negligible.

DOWN DISCHARGE PRESSURE DROP (ADD TO EXTERNAL STATIC PRESSURE)			
CFM [L/s]	600 [283]	800 [378]	1600 [775]
Pressure Drop—Inches W.C. [kPa]	.00	.01 [1.002]	.07 [1.017]
	1000 [472]	1200 [566]	1400 [661]
	.02 [1.005]	.03 [1.007]	.05 [1.012]

[] Designates Metric Conversions



INDOOR AIRFLOW PERFORMANCE—230 VOLTS

Nominal Cooling Capacity Tons [kW]	Motor Speed from Factory	Manufacturer Recommended Air-Flow Range (Min/Max) CFM	Blower Size/ Motor HP [W] & # of Speeds	Motor Speed	External Static Pressure—Inches W.C. [kPa]							
					Side Discharge—Wet Coil							
					0.1 [0.02]	0.2 [0.05]	0.3 [0.07]	0.4 [0.10]	0.5 [0.12]	0.6 [0.15]	0.7 [0.17]	
2.0 [7.03]	High	700 CFM/900 CFM [271/319 L/s]	9x7 Blower 1/4 HP [186] 2 Speed (PSC Motor)	Low	CFM	771 [364]	751 [354]	725 [342]	691 [326]	645 [304]	584 [276]	546 [258]
					RPM	825	870	910	950	985	1010	1030
					Watts	253	242	230	217	204	189	181
2.5 [8.79]	Low	875 CFM/1125 CFM [413/531 L/s]	10x9 Blower 1/2 HP [373] 3 Speed (PSC Motor)	Medium	CFM	946 [446]	922 [435]	882 [416]	830 [392]	769 [363]	701 [331]	630 [297]
					RPM	990	1015	1035	1055	1070	1085	1100
					Watts	315	303	288	273	257	241	226
3.0 [10.55]	High	1050 CFM/1350 CFM [496/637 L/s]	10x9 Blower 1/3 HP [249] 1 Speed (PSC Motor)	High	CFM	1206 [569]	1182 [558]	1157 [546]	1128 [532]	1091 [515]	1044 [493]	983 [464]
					RPM	760	815	870	910	950	975	1000
					Watts	419	406	394	381	368	353	334
3.5 [12.31]	Low (Tap 1)	1225 CFM/1575 CFM [578/743 L/s]	10x9 Blower 3/4 HP [559] 2 Speed (X13 Motor)	High	CFM	1411 [666]	1388 [646]	1327 [626]	1285 [606]	1238 [584]	1183 [558]	1116 [527]
					RPM	865	900	935	970	1000	1020	1035
					Watts	498	498	481	464	447	431	391
4.0 [14.07]	Low (Tap 1)	1350 CFM/1700 CFM [496/802 L/s]	10x9 Blower 3/4 HP [559] 2 Speed (X13 Motor)	High (Tap 2)	CFM	1641 [774]	1577 [744]	1515 [715]	1455 [687]	1393 [657]	1329 [627]	1262 [596]
					RPM	980	1000	1020	1035	1050	1065	1080
					Watts	589	565	543	523	503	481	456
3.0 [10.55]	High	1050 CFM/1350 CFM [496/637 L/s]	10x9 Blower 1/3 HP [249] 1 Speed (PSC Motor)	High	CFM	1391 [656]	1357 [640]	1312 [619]	1258 [594]	1201 [567]	1145 [540]	1093 [516]
					RPM	835	875	915	940	965	985	1000
					Watts	428	419	406	392	378	365	355
3.5 [12.31]	Low (Tap 1)	1225 CFM/1575 CFM [578/743 L/s]	10x9 Blower 3/4 HP [559] 2 Speed (X13 Motor)	Low (Tap 1)	CFM	1467 [692]	1439 [679]	1408 [665]	1360 [642]	1331 [628]	1287 [607]	1259 [594]
					RPM	831	854	894	932	972	1005	1042
					Watts	276	282	297	307	319	326	341
4.0 [14.07]	Low (Tap 1)	1350 CFM/1700 CFM [496/802 L/s]	10x9 Blower 3/4 HP [559] 2 Speed (X13 Motor)	High (Tap 2)	CFM	1550 [732]	1520 [717]	1486 [701]	1449 [684]	1407 [664]	1382 [652]	1337 [631]
					RPM	867	890	930	974	1003	1039	1073
					Watts	317	323	339	355	362	377	385
4.0 [14.07]	Low (Tap 1)	1350 CFM/1700 CFM [496/802 L/s]	10x9 Blower 3/4 HP [559] 2 Speed (X13 Motor)	Low (Tap 1)	CFM	1692 [799]	1661 [784]	1633 [771]	1589 [750]	1560 [736]	1512 [714]	1442 [681]
					RPM	931	950	982	1018	1054	1082	1103
					Watts	404	409	424	434	450	453	443
4.0 [14.07]	Low (Tap 1)	1350 CFM/1700 CFM [496/802 L/s]	10x9 Blower 3/4 HP [559] 2 Speed (X13 Motor)	High (Tap 2)	CFM	1748 [825]	1718 [811]	1686 [796]	1647 [777]	1616 [763]	1543 [728]	1472 [695]
					RPM	955	978	1010	1043	1073	1096	1111
					Watts	440	446	462	475	484	473	459

NOTE: Effect of electric heat strip on airflow performance is negligible.

DOWN DISCHARGE PRESSURE DROP (ADD TO EXTERNAL STATIC PRESSURE)			
CFM [L/s]	600 [283]	800 [378]	1000 [472]
Pressure Drop—Inches W.C. [kPa]	.00	.01 [.002]	.02 [.005]
		1200 [566]	1400 [661]
		.03 [.007]	.05 [.012]
		1600 [775]	.07 [.017]

[] Designates Metric Conversions



INDOOR AIRFLOW PERFORMANCE—208 VOLTS

Nominal Cooling Capacity Tons [kW]	Motor Speed from Factory	Manufacturer Recommended Air-Flow Range (Min/Max) CFM	Blower Size/ Motor HP [W] & # of Speeds	Motor Speed	External Static Pressure—Inches W.C. [kPa] Side Discharge—Wet Coil									
					0.1 [0.2]	0.2 [0.05]	0.3 [0.07]	0.4 [0.10]	0.5 [0.12]	0.6 [0.15]	0.7 [0.17]	0.8 [0.20]		
2.0 [7.03]	High (Tap 1)	700 CFM/900 CFM [271/319 L/s]	9x7 Blower 1/3 HP [372] 3 Speed (X13 Motor)	Low (Tap 1)	CFM	847 [400]	818 [386]	788 [372]	765 [361]	737 [348]	695 [328]	659 [311]	581 [274]	
					RPM	892	818	788	765	737	695	659	581	
					Watts	145	147	156	157	164	167	167	155	
2.5 [8.79]	Low (Tap 1)	875 CFM/1125 CFM [413/531 L/s]	10x9 Blower 1/2 HP [372] 3 Speed (X13 Motor)	Medium (Tap 2)	CFM	914 [431]	887 [419]	853 [403]	824 [389]	793 [374]	762 [360]	717 [338]	602 [284]	
					RPM	934	971	1024	1053	1083	1121	1135	1155	
					Watts	173	177	185	186	188	192	185	164	
3.0 [10.55]	Low (Tap 1)	1050 CFM/1350 CFM [496/637 L/s]	10x9 Blower 1/2 HP [372] 3 Speed (X13 Motor)	High (Tap 3)	CFM	1067 [504]	1034 [488]	992 [468]	957 [452]	912 [430]	820 [387]	778 [367]	729 [344]	
					RPM	719	749	791	819	876	952	983	1024	
					Watts	143	145	155	159	169	182	185	192	
3.5 [12.31]	Low (Tap 1)	1225 CFM/1575 CFM [578/743 L/s]	10x9 Blower 3/4 HP [559] 2 Speed (X13 Motor)	Low (Tap 1)	CFM	1165 [550]	1132 [534]	1091 [515]	1051 [496]	1009 [476]	959 [453]	855 [404]	819 [387]	
					RPM	744	785	833	864	905	951	1020	1053	
					Watts	167	177	188	191	202	206	217	351	
4.0 [14.07]	Low (Tap 1)	1350 CFM/1700 CFM [496/802 L/s]	10x9 Blower 3/4 HP [559] 2 Speed (X13 Motor)	High (Tap 2)	CFM	1252 [591]	1213 [572]	1166 [550]	1137 [537]	1099 [519]	1046 [494]	986 [465]	892 [421]	
					RPM	796	826	868	893	934	982	1026	1086	
					Watts	206	210	219	225	234	245	248	256	
3.0 [10.55]	Low (Tap 1)	1050 CFM/1350 CFM [496/637 L/s]	10x9 Blower 1/2 HP [372] 3 Speed (X13 Motor)	Medium (Tap 2)	CFM	1247 [589]	1220 [576]	1178 [556]	1143 [539]	1099 [519]	1064 [502]	998 [471]	904 [427]	
					RPM	784	819	863	890	932	957	1012	1075	
					Watts	200	208	219	224	233	236	246	256	
3.5 [12.31]	Low (Tap 1)	1225 CFM/1575 CFM [578/743 L/s]	10x9 Blower 3/4 HP [559] 2 Speed (X13 Motor)	High (Tap 3)	CFM	1307 [617]	1292 [610]	1238 [584]	1214 [573]	1170 [552]	1135 [536]	1087 [513]	989 [467]	
					RPM	820	850	889	918	944	981	1028	1087	
					Watts	233	242	248	255	262	268	277	284	
4.0 [14.07]	Low (Tap 1)	1350 CFM/1700 CFM [496/802 L/s]	10x9 Blower 3/4 HP [559] 2 Speed (X13 Motor)	Low (Tap 1)	CFM	1396 [659]	1357 [640]	1334 [630]	1286 [607]	1253 [591]	1207 [570]	1163 [549]	1103 [521]	
					RPM	864	898	920	942	976	1010	1043	1089	
					Watts	268	280	288	292	299	304	310	316	
3.5 [12.31]	Low (Tap 1)	1225 CFM/1575 CFM [578/743 L/s]	10x9 Blower 3/4 HP [559] 2 Speed (X13 Motor)	High (Tap 2)	CFM	1455 [687]	1431 [675]	1396 [659]	1360 [642]	1315 [621]	1285 [606]	1241 [586]		
					RPM	824	856	889	931	968	1009	1041		
					Watts	268	280	288	303	311	325	331		
4.0 [14.07]	Low (Tap 1)	1350 CFM/1700 CFM [496/802 L/s]	10x9 Blower 3/4 HP [559] 2 Speed (X13 Motor)	High (Tap 2)	CFM	1559 [736]	1530 [722]	1488 [702]	1454 [686]	1417 [669]	1375 [649]	1336 [631]		
					RPM	870	893	932	968	1007	1036	1072		
					Watts	321	327	338	351	364	371	381		
3.5 [12.31]	Low (Tap 1)	1225 CFM/1575 CFM [578/743 L/s]	10x9 Blower 3/4 HP [559] 2 Speed (X13 Motor)	Low (Tap 1)	CFM	1675 [791]	1658 [782]	1610 [760]	1580 [746]	1535 [724]	1491 [704]	1422 [671]		
					RPM	923	944	979	1013	1045	1077	1098		
					Watts	390	401	412	425	433	440	432		
4.0 [14.07]	Low (Tap 1)	1350 CFM/1700 CFM [496/802 L/s]	10x9 Blower 3/4 HP [559] 2 Speed (X13 Motor)	High (Tap 2)	CFM	1770 [835]	1751 [826]	1706 [805]	1672 [789]	1624 [766]	1555 [734]	1463 [690]		
					RPM	966	989	1018	1050	1078	1100	1115		
					Watts	454	466	473	486	490	481	460		

NOTE: Effect of electric heat strip on airflow performance is negligible.

DOWN DISCHARGE PRESSURE DROP (ADD TO EXTERNAL STATIC PRESSURE)		
CFM [L/s]	600 [283]	800 [378]
Pressure Drop—Inches W.C. [kPa]	.02 [0.005]	.01 [0.002]
	1000 [472]	1200 [566]
	.02 [0.005]	.03 [0.007]
	1400 [661]	1600 [775]
	.05 [0.012]	.07 [0.017]

[] Designates Metric Conversions



INDOOR AIRFLOW PERFORMANCE—230 VOLTS

Nominal Cooling Capacity Tons [kW]	Motor Speed from Factory	Manufacturer Recommended Air-Flow Range (Min/Max) CFM	Blower Size/ Motor HP [W] & # of Speeds	Motor Speed	External Static Pressure—Inches W.C. [kPa]									
					Side Discharge—Wet Coil									
					0.1 [.02]	0.2 [.05]	0.3 [.07]	0.4 [.10]	0.5 [.12]	0.6 [.15]	0.7 [.17]	0.8 [.20]		
2.0 [7.03]	Low (Tap 1)	700 CFM/900 CFM [271/319 L/s]	9x7 Blower 1/3 HP [249] 3 Speed (X13 Motor)	Low (Tap 1)	CFM	862 [407]	834 [394]	819 [387]	781 [369]	761 [359]	729 [344]	695 [328]	606 [286]	
					RPM	889	953	974	1018	1065	1101	1133	1156	
					Watts	151	159	162	166	173	176	180	165	
2.5 [8.79]	Low (Tap 1)	875 CFM/1125 CFM [413/531 L/s]	10x9 Blower 1/2 HP [372] 3 Speed (X13 Motor)	Medium (Tap 2)	CFM	918 [433]	888 [419]	874 [412]	838 [395]	819 [387]	781 [369]	711 [336]	616 [291]	
					RPM	953	988	1032	1060	1091	1126	1146	1157	
					Watts	181	184	194	198	200	204	189	168	
3.0 [10.55]	Low (Tap 1)	1050 CFM/1350 CFM [496/637 L/s]	10x9 Blower 1/2 HP [372] 3 Speed (X13 Motor)	High (Tap 3)	CFM	1076 [508]	1041 [491]	1017 [480]	970 [458]	928 [438]	852 [402]	785 [370]	745 [352]	
					RPM	715	753	787	825	877	946	1005	1032	
					Watts	144	148	157	169	175	187	198	202	
3.5 [12.31]	Low (Tap 1)	1225 CFM/1575 CFM [578/743 L/s]	10x9 Blower 3/4 HP [559] 2 Speed (X13 Motor)	Low (Tap 1)	CFM	1187 [560]	1124 [530]	1096 [517]	1071 [505]	1024 [483]	987 [466]	896 [423]	852 [402]	
					RPM	762	799	832	859	914	940	1021	1059	
					Watts	176	182	191	196	209	212	227	235	
4.0 [14.07]	Low (Tap 1)	1350 CFM/1700 CFM [496/802 L/s]	10x9 Blower 3/4 HP [559] 2 Speed (X13 Motor)	High (Tap 2)	CFM	1271 [600]	1223 [577]	1169 [552]	1137 [537]	1104 [521]	1071 [505]	1015 [479]	934 [441]	
					RPM	797	836	878	905	939	974	1026	1089	
					Watts	212	217	227	231	241	247	257	270	
3.0 [10.55]	Low (Tap 1)	1050 CFM/1350 CFM [496/637 L/s]	10x9 Blower 1/2 HP [372] 3 Speed (X13 Motor)	Low (Tap 1)	CFM	1258 [594]	1215 [573]	1200 [566]	1160 [547]	1130 [533]	1082 [511]	1026 [484]	954 [450]	
					RPM	802	829	861	894	933	971	1020	1077	
					Watts	210	217	225	230	239	245	259	268	
3.5 [12.31]	Low (Tap 1)	1225 CFM/1575 CFM [578/743 L/s]	10x9 Blower 3/4 HP [559] 2 Speed (X13 Motor)	Medium (Tap 2)	CFM	1336 [631]	1298 [613]	1259 [594]	1229 [580]	1198 [565]	1160 [547]	1116 [527]	1071 [505]	
					RPM	821	867	903	920	957	993	1038	1071	
					Watts	239	249	259	262	275	279	290	299	
3.5 [12.31]	Low (Tap 1)	1225 CFM/1575 CFM [578/743 L/s]	10x9 Blower 3/4 HP [559] 2 Speed (X13 Motor)	High (Tap 3)	CFM	1416 [668]	1379 [651]	1342 [633]	1292 [610]	1275 [602]	1240 [585]	1200 [566]	1168 [551]	
					RPM	874	898	933	952	993	1011	1060	1091	
					Watts	285	290	299	304	314	322	328	337	
3.5 [12.31]	Low (Tap 1)	1225 CFM/1575 CFM [578/743 L/s]	10x9 Blower 3/4 HP [559] 2 Speed (X13 Motor)	Low (Tap 1)	CFM	1467 [692]	1439 [679]	1408 [665]	1360 [642]	1331 [628]	1287 [607]	1259 [594]	1225 [580]	
					RPM	831	854	894	932	972	1005	1042	1071	
					Watts	276	282	297	307	319	326	341	341	
3.5 [12.31]	Low (Tap 1)	1225 CFM/1575 CFM [578/743 L/s]	10x9 Blower 3/4 HP [559] 2 Speed (X13 Motor)	High (Tap 2)	CFM	1550 [732]	1520 [717]	1486 [701]	1449 [684]	1407 [664]	1382 [652]	1337 [631]	1299	
					RPM	867	890	930	974	1003	1039	1073	1091	
					Watts	317	323	339	355	362	377	385	385	
4.0 [14.07]	Low (Tap 1)	1350 CFM/1700 CFM [496/802 L/s]	10x9 Blower 3/4 HP [559] 2 Speed (X13 Motor)	Low (Tap 1)	CFM	1692 [799]	1661 [784]	1633 [771]	1589 [750]	1560 [736]	1512 [714]	1442 [681]	1403	
					RPM	931	950	982	1018	1054	1082	1103	1103	
					Watts	404	409	424	434	450	453	443	443	
4.0 [14.07]	Low (Tap 1)	1350 CFM/1700 CFM [496/802 L/s]	10x9 Blower 3/4 HP [559] 2 Speed (X13 Motor)	High (Tap 2)	CFM	1748 [825]	1718 [811]	1686 [796]	1647 [777]	1616 [778]	1543 [779]	1472 [780]	1411	
					RPM	955	978	1010	1043	1073	1096	1111	1111	
					Watts	440	446	462	475	484	473	459	459	

NOTE: Effect of electric heat strip on airflow performance is negligible.

DOWN DISCHARGE PRESSURE DROP (ADD TO EXTERNAL STATIC PRESSURE)			
CFM [L/s]	600 [283]	800 [378]	1600 [775]
Pressure Drop—Inches W.C. [kPa]	.00	.01 [.002]	.07 [.017]

[] Designates Metric Conversions



ELECTRICAL DATA—RQNL-B/RQPL-B SERIES

ELECTRICAL DATA – RQNL-B SERIES									
		-B024JK	-B030JK	-B036CK	-B036JK	-B042CK	-B042JK	-B048CK	-B048JK
Unit Information	Unit Operating Voltage Range	187-253	187-253	187-253	187-253	187-253	187-253	187-253	187-253
	Minimum Circuit Ampacity	19/19	22/22	17/17	24/24	25/25	33/33	26/26	37/37
	Minimum Overcurrent Protection Device Size	25/25	25/25	20/20	25/25	30/30	35/35	30/30	40/40
	Maximum Overcurrent Protection Device Size	30/30	35/35	25/25	40/40	35/35	50/50	35/35	50/50
Compressor Motor	No.	1	1	1	1	1	1	1	1
	Volts	208/230	208/230	208/230	208/230	208/230	208/230	208/230	208/230
	Phase	1	1	3	1	3	1	3	1
	HP	2	2 1/2	3	3	3 1/2	3 1/2	4	4
	RPM	3450	3450	3450	3450	3450	3450	3450	3450
	Amps (RLA)	12.8/12.8	14.1/14.1	10.4/10.4	16.7/16.7	13.1/13.1	19.9/19.9	13.7/13.7	23.8/23.8
	Amps (LRA)	58.3/58.3	73/73	88/88	79/79	83.1/83.1	109/109	83.1/83.1	117/117
Condenser Motor	No.	1	1	1	1	1	1	1	1
	Volts	208/230	208/230	208/230	208/230	208/230	208/230	208/230	208/230
	Phase	1	1	1	1	1	1	1	1
	HP	1/5	1/5	1/5	1/5	1/3	1/3	1/3	1/3
	Amps (FLA)	1.3	1.3	1.3	1.3	2	2	2	2
	Amps (LRA)	2.2	2.2	2.2	2.2	3.9	3.9	3.9	3.9
Evaporator Fan	No.	1	1	1	1	1	1	1	1
	Volts	208/230	208/230	208/230	208/230	208/230	208/230	208/230	208/230
	Phase	1	1	1	1	1	1	1	1
	HP	1/4	1/2	1/3	1/3	3/4	3/4	3/4	3/4
	Amps (FLA)	1.5	2.4	1.7	1.7	6	6	6	6
	Amps (LRA)	2.4	5.1	2.5	2.5	0	0	0	0

ELECTRICAL DATA – RQPL-B SERIES									
		-B024JK	-B030JK	-B036CK	-B036JK	-B042CK	-B042JK	-B048CK	-B048JK
Unit Information	Unit Operating Voltage Range	187-253	187-253	187-253	187-253	187-253	187-253	187-253	187-253
	Minimum Circuit Ampacity	21/21	24/24	19/19	27/27	25/25	33/33	26/26	37/37
	Minimum Overcurrent Protection Device Size	25/25	25/25	20/20	30/30	30/30	35/35	30/30	40/40
	Maximum Overcurrent Protection Device Size	30/30	35/35	25/25	40/40	35/35	50/50	35/35	50/50
Compressor Motor	No.	1	1	1	1	1	1	1	1
	Volts	208/230	208/230	208/230	208/230	208/230	208/230	208/230	208/230
	Phase	1	1	3	1	3	1	3	1
	HP	2	2 1/2	3	3	3 1/2	3 1/2	4	4
	RPM	3450	3450	3450	3450	3450	3450	3450	3450
	Amps (RLA)	12.8/12.8	14.1/14.1	10.4/10.4	16.7/16.7	13.1/13.1	19.9/19.9	13.7/13.7	23.8/23.8
	Amps (LRA)	58.3/58.3	73/73	88/88	79/79	83.1/83.1	109/109	83.1/83.1	117/117
Condenser Motor	No.	1	1	1	1	1	1	1	1
	Volts	208/230	208/230	208/230	208/230	208/230	208/230	208/230	208/230
	Phase	1	1	1	1	1	1	1	1
	HP	1/5	1/5	1/5	1/5	1/3	1/3	1/3	1/3
	Amps (FLA)	1.3	1.3	1.3	1.3	2	2	2	2
	Amps (LRA)	2.2	2.2	2.2	2.2	3.9	3.9	3.9	3.9
Evaporator Fan	No.	1	1	1	1	1	1	1	1
	Volts	208/230	208/230	208/230	208/230	208/230	208/230	208/230	208/230
	Phase	1	1	1	1	1	1	1	1
	HP	1/3	1/2	1/2	1/2	3/4	3/4	3/4	3/4
	Amps (FLA)	2.8	4.1	4.1	4.1	6	6	6	6
	Amps (LRA)	0	0	0	0	0	0	0	0

1. Horsepower Per Compressor.
2. Amp Draw Per Motor. Multiply Value By Number of Motors to Determine Total Amps.

Unit Model Application	Electric Heater Kit Models
RQNL/RQPL-B024JK	RXQJ-A05J (208-240 volt, 1-ph, 5kW)
	RXQJ-A10J (208-240 volt, 1-ph, 10kW)
RQNL/RQPL-B030JK	RXQJ-A05J (208-240 volt, 1-ph, 5kW)
	RXQJ-A10J (208-240 volt, 1-ph, 10kW)
RQNL/RQPL-B036JK	RXQJ-A10J (208-240 volt, 1-ph, 10kW)
	RXQJ-A15J (208-240 volt, 1-ph, 15kW)
RQNL/RQPL-B042JK	RXQJ-B10J (208-240 volt, 1-ph, 10kW)
	RXQJ-B15J (208-240 volt, 1-ph, 15kW)
RQNL/RQPL-B048JK	RXQJ-B10J (208-240 volt, 1-ph, 10kW)
	RXQJ-B15J (208-240 volt, 1-ph, 15kW)
RQNL/RQPL-B036CK	RXQJ-A10C (208-240 volt, 3-ph, 10kW)
	RXQJ-A15C (208-240 volt, 3-ph, 15kW)
RQNL/RQPL-B042CK	RXQJ-A10C (208-240 volt, 3-ph, 10kW)
	RXQJ-A15C (208-240 volt, 3-ph, 15kW)
RQNL/RQPL-B048CK	RXQJ-A10C (208-240 volt, 3-ph, 10kW)
	RXQJ-A15C (208-240 volt, 3-ph, 15kW)

WARNING

ONLY ELECTRIC HEATER KITS SUPPLIED BY THIS MANUFACTURER AS DESCRIBED IN THIS PUBLICATION HAVE BEEN DESIGNED, TESTED, AND EVALUATED BY A NATIONALLY RECOGNIZED SAFETY TESTING AGENCY FOR USE WITH THIS UNIT. USE OF ANY OTHER MANUFACTURED ELECTRIC HEATERS INSTALLED WITHIN THIS UNIT MAY CAUSE HAZARDOUS CONDITIONS RESULTING IN PROPERTY DAMAGE, FIRE, BODILY INJURY OR DEATH.



ELECTRIC HEATER KITS—RQNL-B SERIES

208-240 VOLT, SINGLE PHASE, 60 HZ, AUXILIARY ELECTRIC HEATER KITS CHARACTERISTICS AND APPLICATION

Single Power Supply For Both Unit and Heater Kit										Separate Power Supply For Both Unit and Heater Kit					
Unit Model No. RQNL-	Heater Kit					Heat Pump					Heater Kit			Heat Pump	
	RXOJ-Heater Kit Nominal kW	No. of Elements	No. of Sequence Steps	Rated Heater kW @ 208-240 V	Heater KBTU/Hr @ 208-240 V	Heater Amp. @ 208-240 V	Unit Min. Ckt. Ampacity @ 208-240 V	Over Current Protective Device Size		Min. Ckt. Ampacity 208/240V	Max. Fuse Size 208/240V	Min. Circuit Ampacity 208-240 V	Over Current Protective Device Size		
								Min./Max. @ 208 V	Min./Max. @ 240 V				Min./Max. @ 208 V	Min./Max. @ 240 V	
B024JK	No Heat	—	—	—	—	—	19/19	30/30	30/30	—	—	19/19	30/30	30/30	
	A05J	1	1	3.6/4.8	12.28/16.38	17.3/20.0	41/44	45/50	45/50	22/25	25/25	—	—	—	
	A10J	2	2	7.2/9.6	24.56/32.75	34.6/40.0	62/69	70/70	70/70	44/50	45/50	—	—	—	
B030JK	No Heat	—	—	—	—	—	22/22	35/35	35/35	—	—	22/22	35/35	35/35	
	A05J	1	1	3.6/4.8	12.28/16.38	17.3/20.0	43/47	50/50	50/50	22/25	25/25	—	—	—	
	A10J	2	2	7.2/9.6	24.56/32.75	34.6/40.0	65/72	70/80	70/80	44/50	45/50	—	—	—	
B036JK	No Heat	—	—	—	—	—	24/24	40/40	40/40	—	—	24/24	40/40	40/40	
	A10J	2	2	7.2/9.6	24.56/32.75	34.6/40.0	68/74	70/80	70/80	44/50	45/50	—	—	—	
	A15J	3	3	10.8/14.4	36.84/49.13	51.9/60.0	89/99	90/100	90/100	65/75	70/80	—	—	—	
B042JK	No Heat	—	—	—	—	—	33/33	50/50	50/50	—	—	33/33	50/50	50/50	
	B10J	2	2	7.2/9.6	24.56/32.75	34.6/40.0	77/83	80/90	80/90	44/50	45/50	—	—	—	
	B15J	3	3	10.8/14.4	36.84/49.13	51.9/60.0	98/108	100/110	100/110	65/75	70/80	—	—	—	
B048JK	No Heat	—	—	—	—	—	37/37	50/50	50/50	—	—	37/37	50/50	50/50	
	B10J	2	2	7.2/9.6	24.56/32.75	34.6/40.0	80/87	90/90	90/90	44/50	45/50	—	—	—	
	B15J	3	3	10.8/14.4	36.84/49.13	51.9/60.0	102/112	110/125	110/125	65/75	70/80	—	—	—	

208-240 VOLT, THREE PHASE, 60 HZ, AUXILIARY ELECTRIC HEATER KITS CHARACTERISTICS AND APPLICATION

Single Power Supply For Both Unit and Heater Kit										Separate Power Supply For Both Unit and Heater Kit					
Unit Model No. RQNL-	Heater Kit					Heat Pump					Heater Kit			Heat Pump	
	RXOJ-Heater Kit Nominal kW	No. of Elements	No. of Sequence Steps	Rated Heater kW @ 208-240 V	Heater KBTU/Hr @ 208-240 V	Heater Amp. @ 208-240 V	Unit Min. Ckt. Ampacity @ 208-240 V	Over Current Protective Device Size		Min. Ckt. Ampacity 208/240V	Max. Fuse Size 208/240V	Min. Circuit Ampacity 208-240 V	Over Current Protective Device Size		
								Min./Max. @ 208 V	Min./Max. @ 240 V				Min./Max. @ 208 V	Min./Max. @ 240 V	
B036CK	No Heat	—	—	—	—	—	17/17	25/25	25/25	—	—	17/17	25/25	25/25	
	A10C	3	3	7.2/9.6	24.56/32.75	20.0/23.1	42/45	45/45	45/45	25/29	25/30	—	—	—	
	A15C	3	3	10.8/14.4	36.84/49.13	30.1/34.7	54/60	60/60	60/60	38/44	40/45	—	—	—	
B042CK	No Heat	—	—	—	—	—	25/25	35/35	35/35	—	—	25/25	35/35	35/35	
	A10C	3	3	7.2/9.6	24.56/32.75	20.0/23.1	50/54	50/60	50/60	25/29	25/30	—	—	—	
	A15C	3	3	10.8/14.4	36.84/49.13	30.1/34.7	63/68	70/70	70/70	38/44	40/45	—	—	—	
B048CK	No Heat	—	—	—	—	—	26/26	35/35	35/35	—	—	26/26	35/35	35/35	
	A10C	3	3	7.2/9.6	24.56/32.75	20.0/23.1	51/55	60/60	60/60	25/29	25/30	—	—	—	
	A15C	3	3	10.8/14.4	36.84/49.13	30.1/34.7	63/69	70/70	70/70	38/44	40/45	—	—	—	

ELECTRIC HEATER KITS—RQPL-B SERIES



208-240 VOLT, SINGLE PHASE, 60 HZ, AUXILIARY ELECTRIC HEATER KITS CHARACTERISTICS AND APPLICATION														
Single Power Supply For Both Unit and Heater Kit						Separate Power Supply For Both Unit and Heater Kit								
Unit Model No. RQPL-	Heater Kit					Heat Pump					Heater Kit		Heat Pump	
	RXQJ-Heater Kit Nominal kW	No. of Elements	No. of Sequence Steps	Rated Heater kW @ 208-240 V	Heater KBTU/Hr @ 208-240 V	Heater Amp. @ 208-240 V	Unit Min. Ckt. Ampacity @ 208-240 V	Over Current Protective Device Size		Min. Ckt. Ampacity 208-240 V	Max. Fuse Size 208/240V	Min./Max. @ 208 V	Over Current Protective Device Size Min./Max. @ 240 V	
								Min./Max. @ 208 V	Min./Max. @ 240 V					
B024JK	No Heat A05J A10J	1 2	—	3.6/4.8 7.2/9.6	12.28/16.38 24.56/32.75	17.3/20.0 34.6/40.0	21/21 42/46 64/71	30/30 50/50 70/80	30/30 50/50 70/80	21/21	—	30/30	30/30	
B030JK	No Heat A05J A10J	1 2	—	3.6/4.8 7.2/9.6	12.28/16.38 24.56/32.75	17.3/20.0 34.6/40.0	24/24 48/49 67/74	35/35 50/50 70/80	35/35 50/50 70/80	24/24	—	35/35	35/35	
B036JK	No Heat A10J A15J	2 3	—	7.2/9.6 10.8/14.4	24.56/32.75 36.84/49.13	34.6/40.0 51.9/60.0	27/27 92/102	40/40 70/80 100/110	40/40 70/80 100/110	27/27	—	40/40	40/40	
B042JK	No Heat B10J B15J	2 3	—	7.2/9.6 10.8/14.4	24.56/32.75 36.84/49.13	34.6/40.0 51.9/60.0	33/33 77/83 98/108	50/50 80/90 100/110	50/50 80/90 100/110	—	—	50/50	50/50	
B048JK	No Heat B10J B15J	2 3	—	7.2/9.6 10.8/14.4	24.56/32.75 36.84/49.13	34.6/40.0 51.9/60.0	37/37 80/87 102/112	50/50 90/90 110/125	50/50 90/90 110/125	37/37	—	50/50	50/50	

208-240 VOLT, THREE PHASE, 60 HZ, AUXILIARY ELECTRIC HEATER KITS CHARACTERISTICS AND APPLICATION														
Single Power Supply For Both Unit and Heater Kit						Separate Power Supply For Both Unit and Heater Kit								
Unit Model No. RQPL-	Heater Kit					Heat Pump					Heater Kit		Heat Pump	
	RXQJ-Heater Kit Nominal kW	No. of Elements	No. of Sequence Steps	Rated Heater kW @ 208-240 V	Heater KBTU/Hr @ 208-240 V	Heater Amp. @ 208-240 V	Unit Min. Ckt. Ampacity @ 208-240 V	Over Current Protective Device Size		Min. Ckt. Ampacity 208-240 V	Max. Fuse Size 208/240V	Min./Max. @ 208 V	Over Current Protective Device Size Min./Max. @ 240 V	
								Min./Max. @ 208 V	Min./Max. @ 240 V					
B036CK	No Heat A10C A15C	3 3	—	7.2/9.6 10.8/14.4	24.56/32.75 36.84/49.13	20.0/23.1 30.1/34.7	19/19 44/48 57/62	25/25 45/50 60/70	25/25 45/50 60/70	—	—	25/25	25/25	
B042CK	No Heat A10C A15C	3 3	—	7.2/9.6 10.8/14.4	24.56/32.75 36.84/49.13	20.0/23.1 30.1/34.7	25/25 50/54 63/68	35/35 50/60 70/70	35/35 50/60 70/70	25/25	—	35/35	35/35	
B048CK	No Heat A10C A15C	3 3	—	7.2/9.6 10.8/14.4	24.56/32.75 36.84/49.13	20.0/23.1 30.1/34.7	26/26 51/55 63/69	35/35 60/60 70/70	35/35 60/60 70/70	26/26	—	35/35	35/35	

UNIT DIMENSIONS SELF-CONTAINED AIR CONDITIONERS

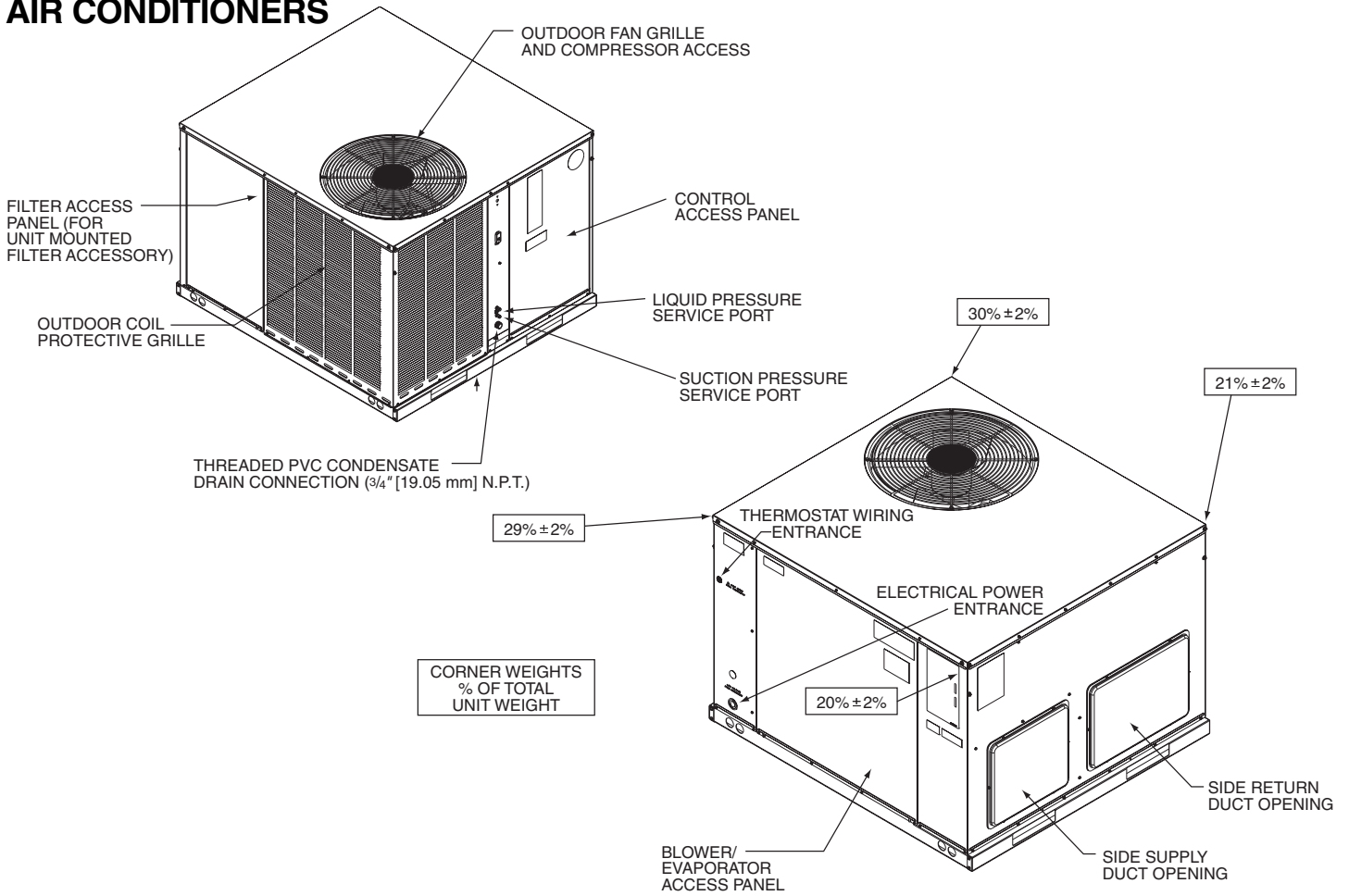

TOP VIEW

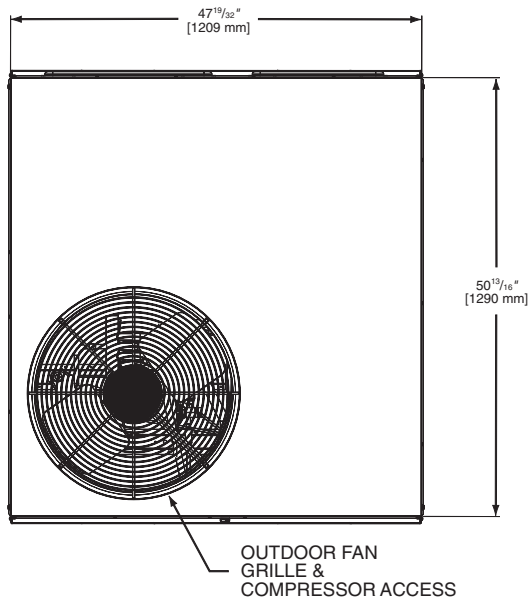

BOTTOM VIEW

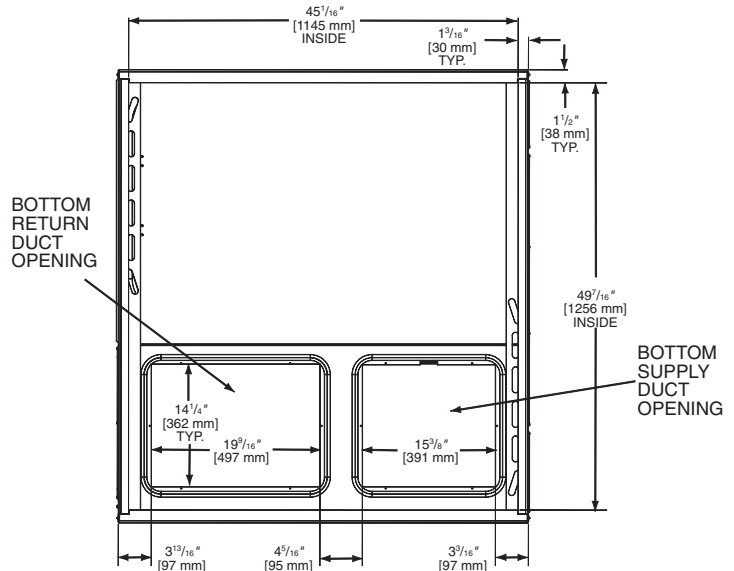

[] Designates Metric Conversions

SIDE VIEW

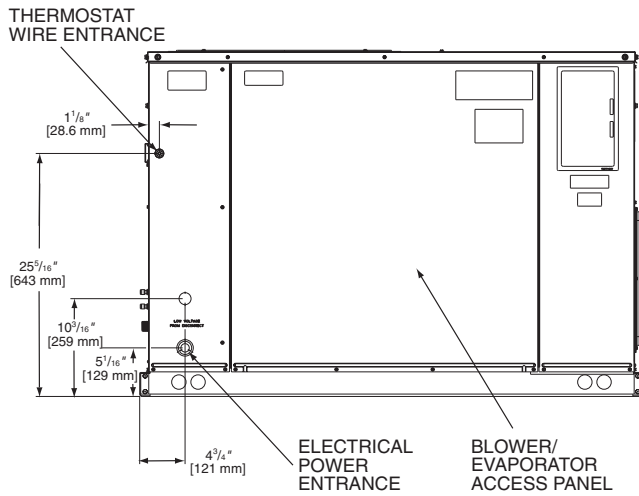

SIDE VIEW

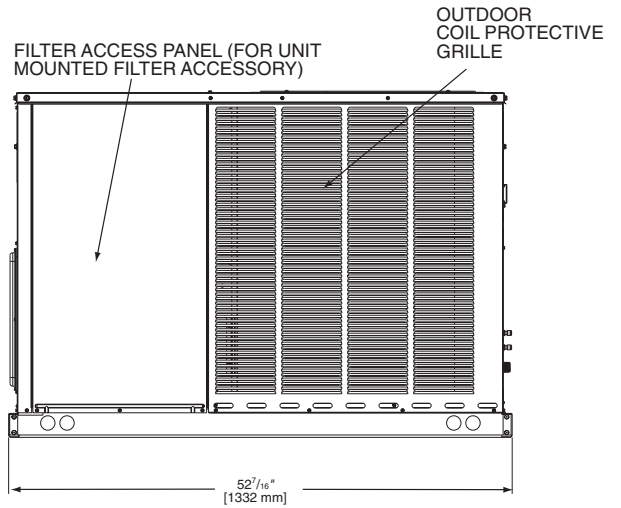

FRONT VIEW

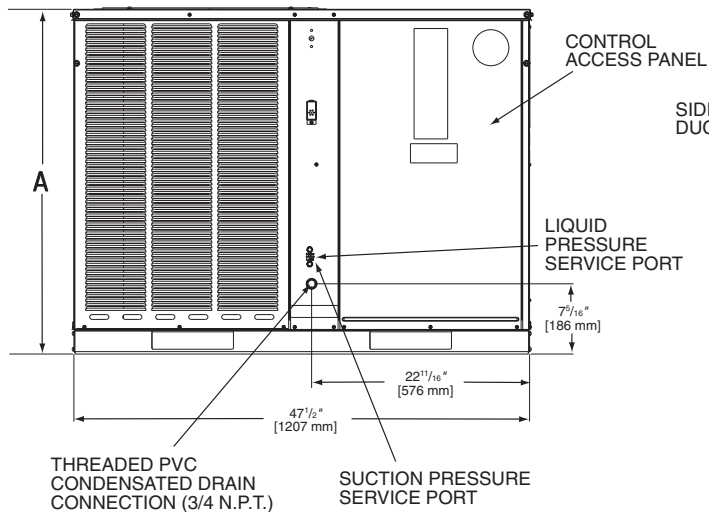

BACK VIEW

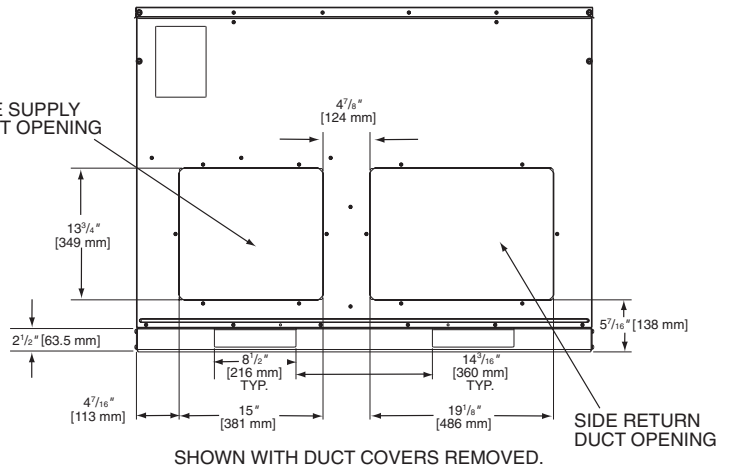

IMPORTANT:
 INSTALLATION MUST NOT INTERFERE WITH DRAINAGE OPENINGS IN BOTTOM OF UNIT UNDER OUTDOOR COIL.

Model Number	Height "A"
B024	35 ¹⁵ / ₁₆
B030, B036, B042, B048	41

IMPORTANT:
 UNIT MUST BE LEVEL TO PREVENT WATER MIGRATION.

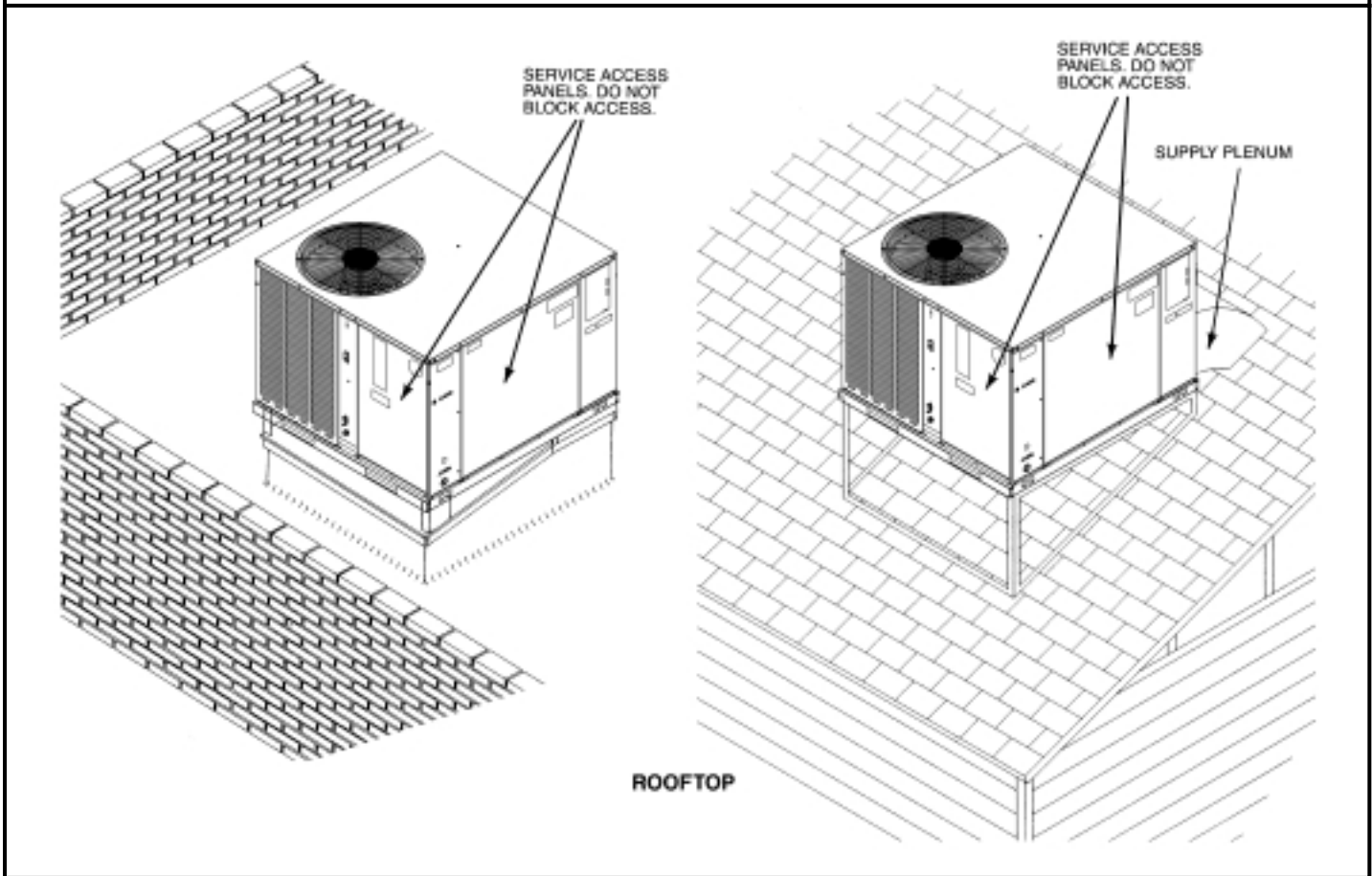
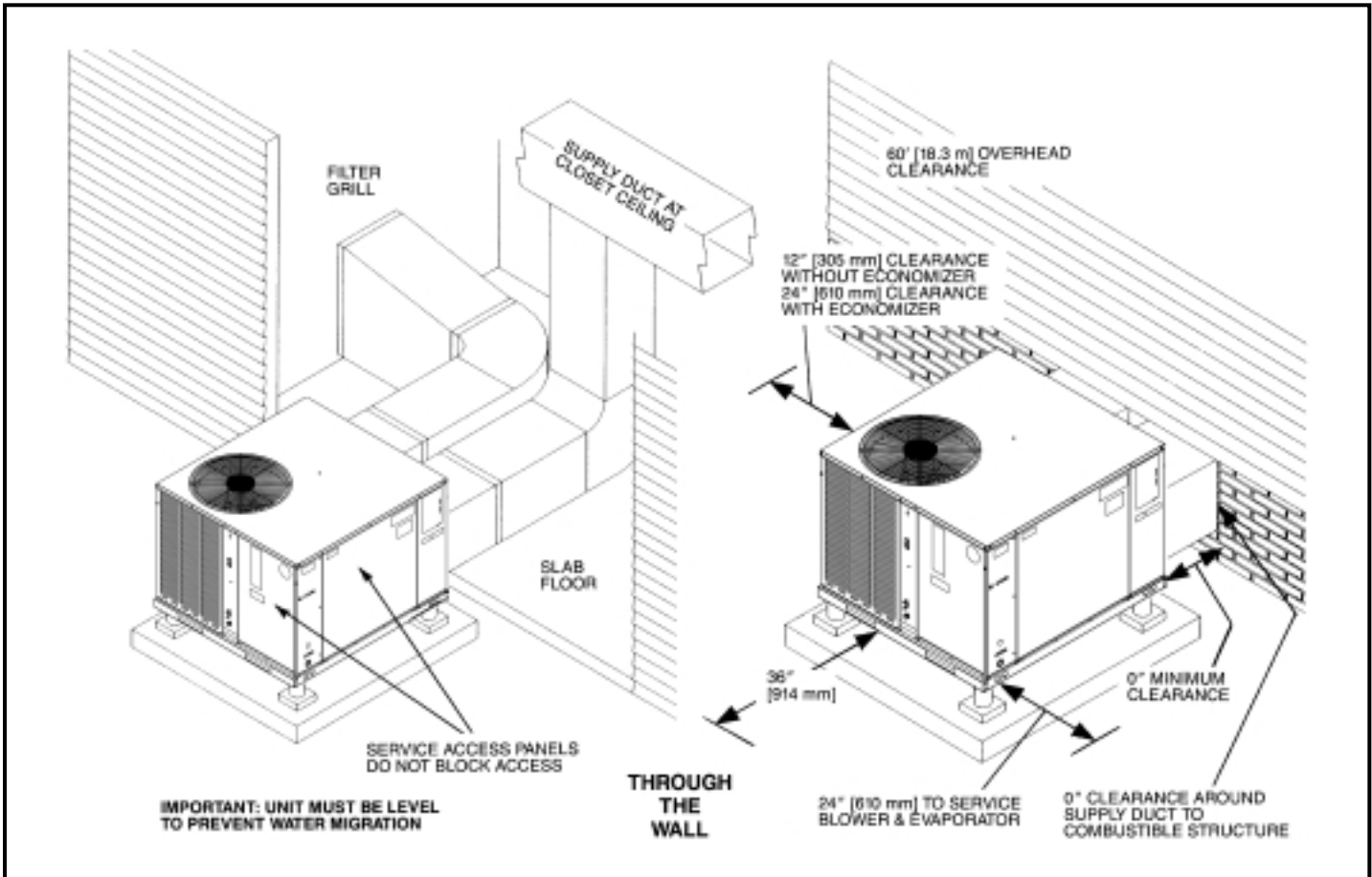

ACCESSORY EQUIPMENT

Accessory Description	Model Application	Accessory Model No.
Roofcurbs	RQNL-B/RQPL-B	RXQG-AAA14 (14" [356 mm] Height) RXQG-AAA24 (24" [610 mm] Height)
Supply & Return Diffusers	RQNL-B/RQPL-B	RXRN-BD15
Economizers (Downflow Only)	RQNL-B/RQPL-B	RXRE-CAA30 (3 Position) RXRD-CAM10 (Fully Modulating)
Fresh Air Damper	RQNL-B/RQPL-B	RXRF-FAB1 (Motorized-35%) RXRF-FAA1 (Fixed-35%)
Rectangular to Round Transition (Downflow)	RQNL-B/RQPL-B	RXMC-CA02 (16" [406 mm] Ducts) RXMC-CA03 (18" [457 mm] Ducts)
Filter Kit	RQNL-B/RQPL-B	RXRY-B01
High Pressure Control	RQNL-B/RQPL-B	RXAB-A04
Outdoor Thermostat	RQNL-B/RQPL-B	RXPT-A01
Low Ambient Control	RQNL-B/RQPL-B	RXPZ-C01 or RXPZ-F01
Duct Adapter Sideflow Square to Round Transition	RQNL-B/RQPL-B	RXMC-BA01
Lift Kit	RQNL-B/RQPL-B	RXML-A01

COMMON SUPPLY/RETURN CONCENTRIC AIR DIFFUSER

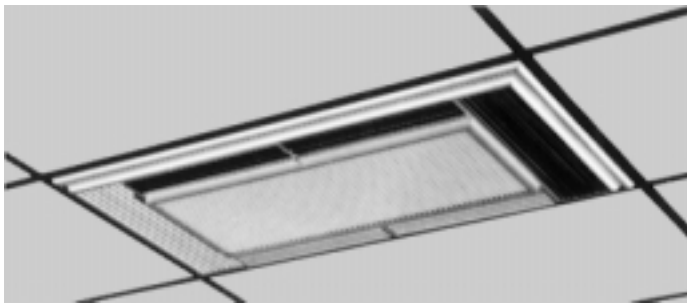

DIFFUSER INSTALLS FLUSH WITH CEILING

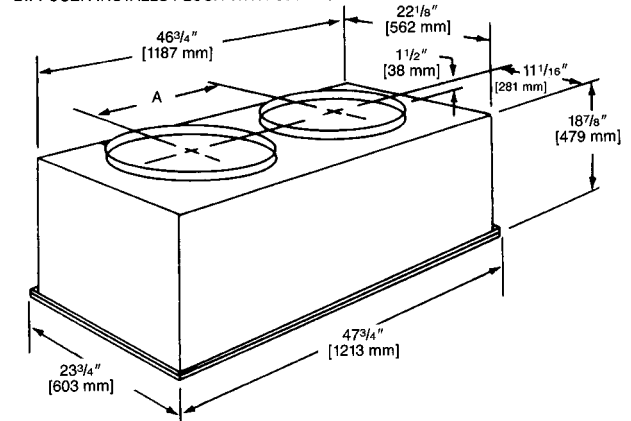

SUPPLY/RETURN DIFFUSER

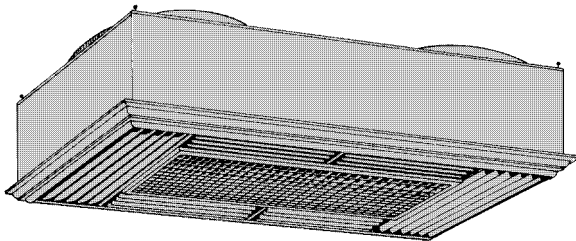

Designed to convert a side by side or an over and under arrangement into a concentric distribution of air. The diffuser is flush mounted, completely insulated, assembled, and internally baffled to provide four way supply air distribution with a center return. To make the assembly complete and ready to fit into a 2' [0.61 m] x 4' [1.22 m] suspended ceiling grid, the diffuser includes adjustable supply louvers, hanging rings, anti-sweat gasket, and round flanges for use with flexible ducts.

Model No.	Diameter Inches [mm]	Shipping Wt. Lbs. [kg]	Dimension A Inches [mm]
RXRN-BD15	16 [406]	90 [40.82]	20 1/2 [521]

NOTE: The location of the combination supply and return diffuser should not exceed 10 feet [3.05 m] above the floor level for units @ 1000 CFM [472 L/s] or less and 12 [3.66 m] to 14 feet [4.27 m] above the floor level for units with CFM greater than 1000 [472 L/s]. If the diffuser is installed with a greater distance than recommended above, the supply air may become stratified above the required comfort area causing uncomfortable conditions.

AIRFLOW/PRESSURE DROP INFORMATION (INCHES W.C. [kPa])

Accessory	Approximate CFM [L/s]-Supply Air			
	1300 [614]	1575 [743]	1800 [850]	2200 [1038]
Plenum & Supply/Return Duct	.07 [.017]	.10 [.024]	.12 [.030]	.17 [.042]
Diffuser	.09 [.022]	.13 [.032]	.16 [.040]	.24 [.060]
Economizer	.06 [.015]	.09 [.022]	.11 [.027]	.17 [.042]

SUPPLY AIR/PERFORMANCE

Diffuser Airflow CFM [L/s]	Range of Throw Ft. [m]
800 [378]-1200 [566]	14 [4.27]-16 [4.88]
1600 [755]-2000 [944]	18 [5.49]-28 [8.53]

[] Designates Metric Conversions

DUCT ADAPTERS RECTANGULAR TO ROUND TRANSITIONS (DOWNFLOW)

RXMC-CA02

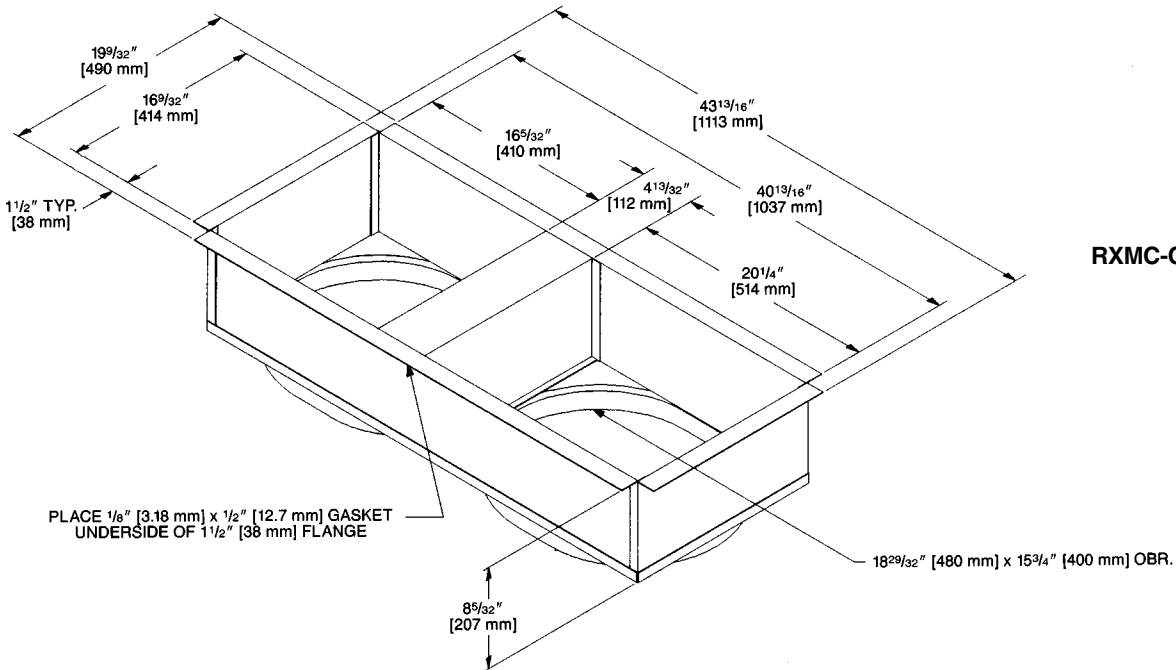
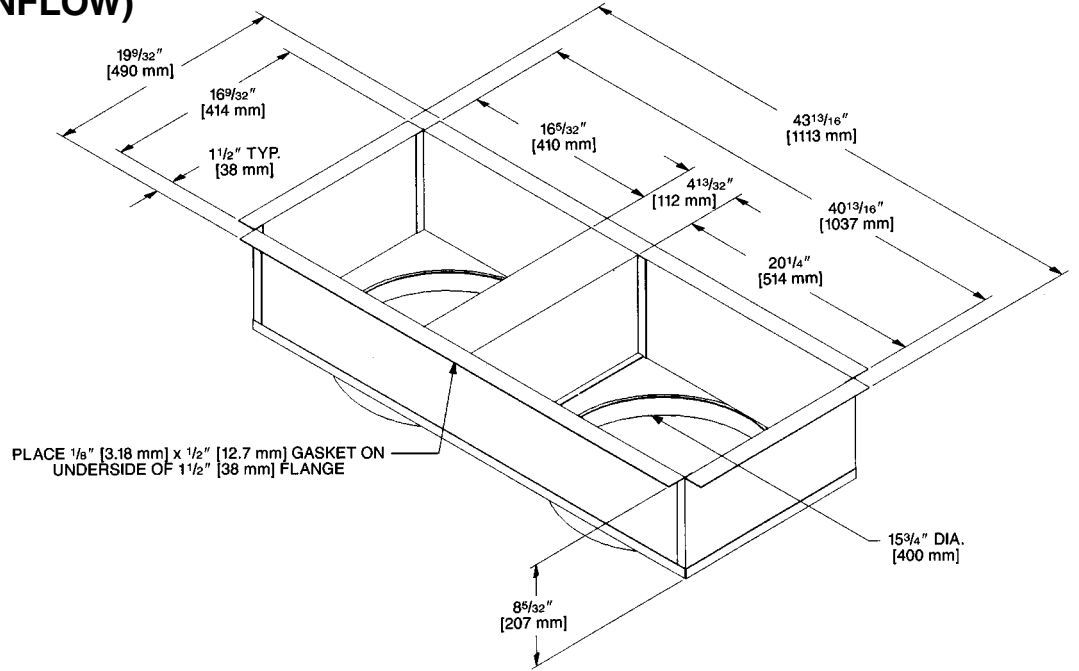

RXMC-CA03

[] Designates Metric Conversions

FRESH AIR DAMPER FOR USE ON RQNL-B/RQPL-B SERIES

RXRF-FAA1 (Fixed - 0-35%)

The 0-35% manual outside Air Damper is designed to replace the unit return air duct cover. No drilling or damper assembly is required. The amount of outside air (0-35%) is controlled by simply adjusting the side damper.

RXRF-FAB1 (Motorized - 0-35%)

The 0-35% motorized outside Air Damper is designed to replace the unit return air duct cover. No drilling or damper assembly is required. The control motor opens the adjustable slide damper when the unit blower motor is energized.

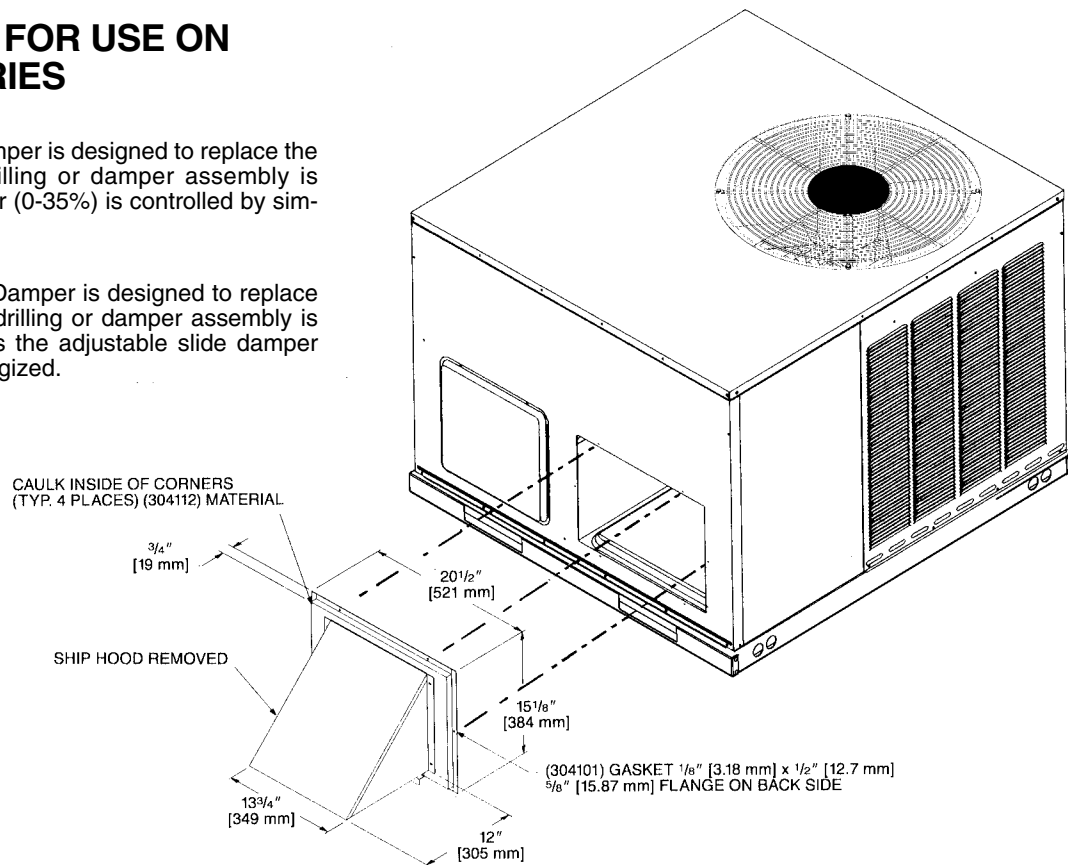

ECONOMIZERS

RXRE-CAA30 (3 Position) and RXRD-CAM10 (Fully Modulating) for RQNL-B/RQPL-B Series Downflow Application

RXRE-CAA30 (3 Position)

Provided with enthalpy control, and mixed air sensor. Settings include fully open, fully closed and adjustable mid point.

RXRD-CAM10 (Fully Modulating)

Provided with enthalpy control, mixed air sensor and minimum position potentiometer for proportioning (modulating) the amount of fresh air.

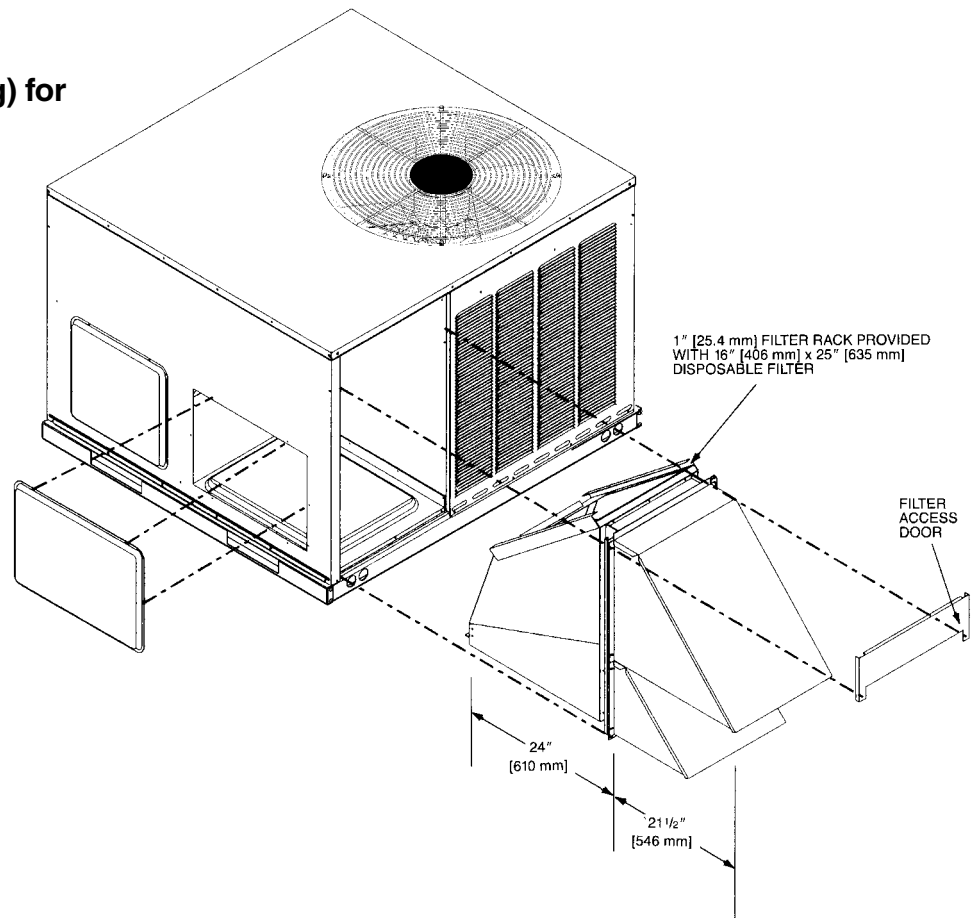

[] Designates Metric Conversions

ECONOMIZERS

RXRE-CAA30 (3 Position) and RXRD-CCM1C (Fully Modulating) for RQNL-B/RQPL-B Series Horizontal Application

RXRE-CAA30 (3 Position)

Provided with enthalpy control, and mixed air sensor. Settings include fully open, fully closed and adjustable mid point.

RXRD-CCM10 (Fully Modulating)

Provided with enthalpy control, mixed air sensor and minimum position potentiometer for proportioning (modulating) the amount of fresh air.

[] Designates Metric Conversions

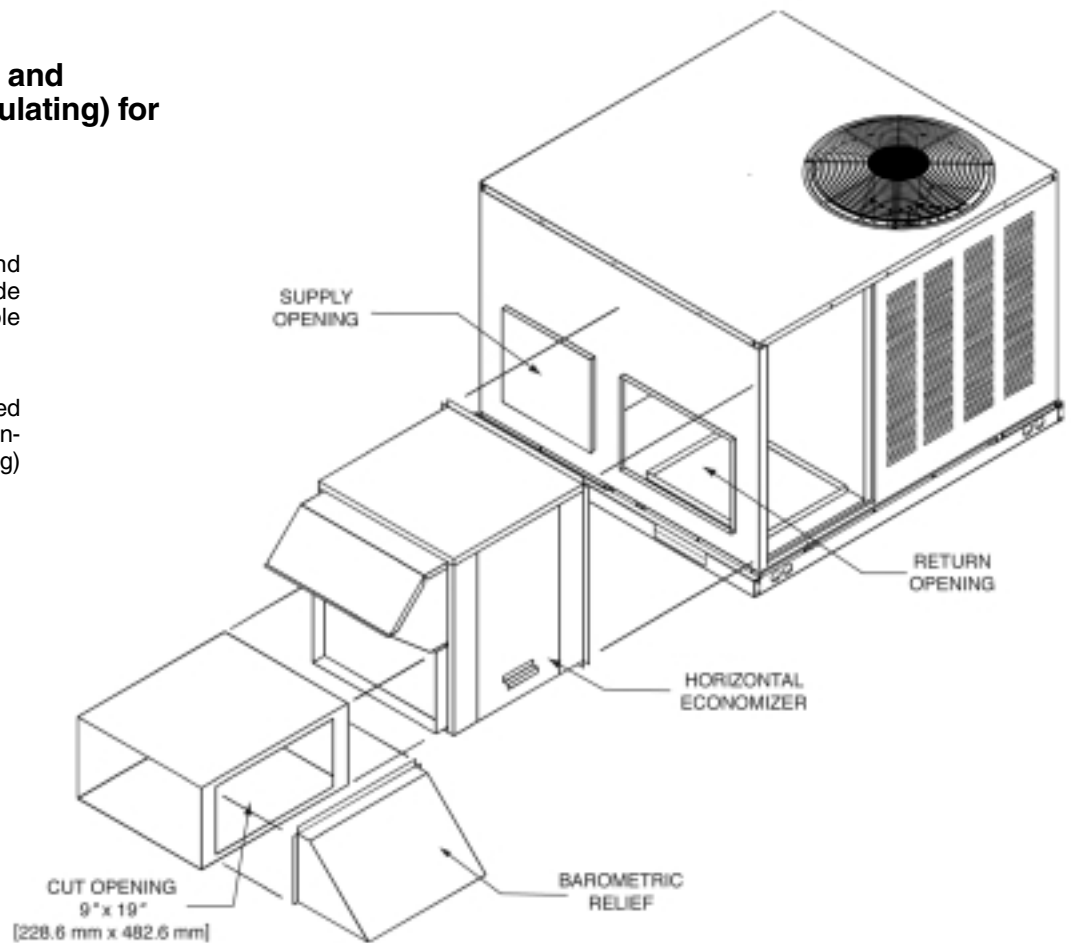

FILTER KIT INSTALLATION RXRY-B01

For use in either vertical
or horizontal discharge.

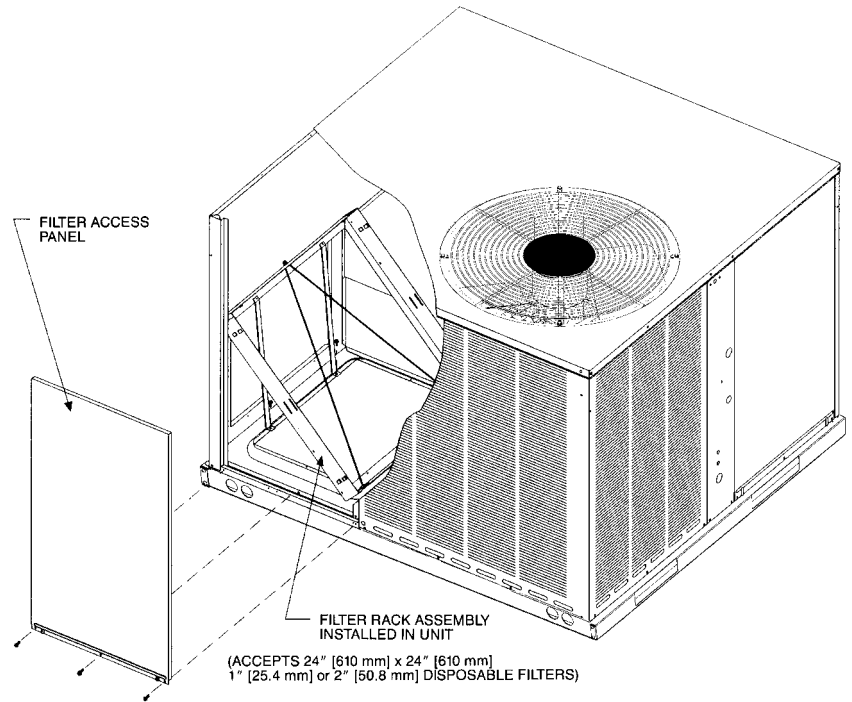

	CFM [L/s]	
Minimum Airflow	Nominal Airflow	Maximum Airflow
510 [241]	600 [283]	660 [311]
680 [321]	800 [378]	880 [415]
850 [401]	1000 [472]	1100 [519]
1020 [481]	1200 [566]	1320 [623]
1190 [562]	1400 [661]	1540 [727]
1275 [602]	1500 [708]	1650 [779]
1700 [802]	2000 [944]	2200 [1039]

[] Designates Metric Conversions

Airflow Pressure Drop, Inches W.C. [kPa]		
CFM [L/s]	1" Filter	2" Filter
500 [236]	.02 [.0050]	.03 [.0075]
600 [283]	.02 [.0050]	.03 [.0075]
700 [330]	.03 [.0075]	.04 [.0010]
800 [378]	.04 [.0010]	.05 [.0124]
900 [425]	.05 [.0124]	.06 [.0149]
1000 [472]	.07 [.0174]	.08 [.0199]
1100 [519]	.08 [.0199]	.09 [.0224]
1200 [566]	.10 [.0249]	.12 [.0299]
1300 [614]	.13 [.0324]	.15 [.0373]
1400 [661]	.16 [.0398]	.19 [.0473]
1500 [708]	.19 [.0473]	.21 [.0523]
1600 [755]	.20 [.0498]	.23 [.0572]
1700 [802]	.21 [.0523]	.24 [.0598]
1800 [850]	.22 [.0548]	.25 [.0623]
1900 [897]	.24 [.0598]	.27 [.0672]
2000 [944]	.26 [.0647]	.29 [.0722]

DUCT ADAPTER SIDEFLOW SQUARE TO ROUND TRANSITION RXMC-BA01

Adapts the side rectangular supply and return openings to 14" [356 mm] diameter round openings. Adapters provided with same finish as unit and also provided with thermal insulation.

[] Designates Metric Conversions

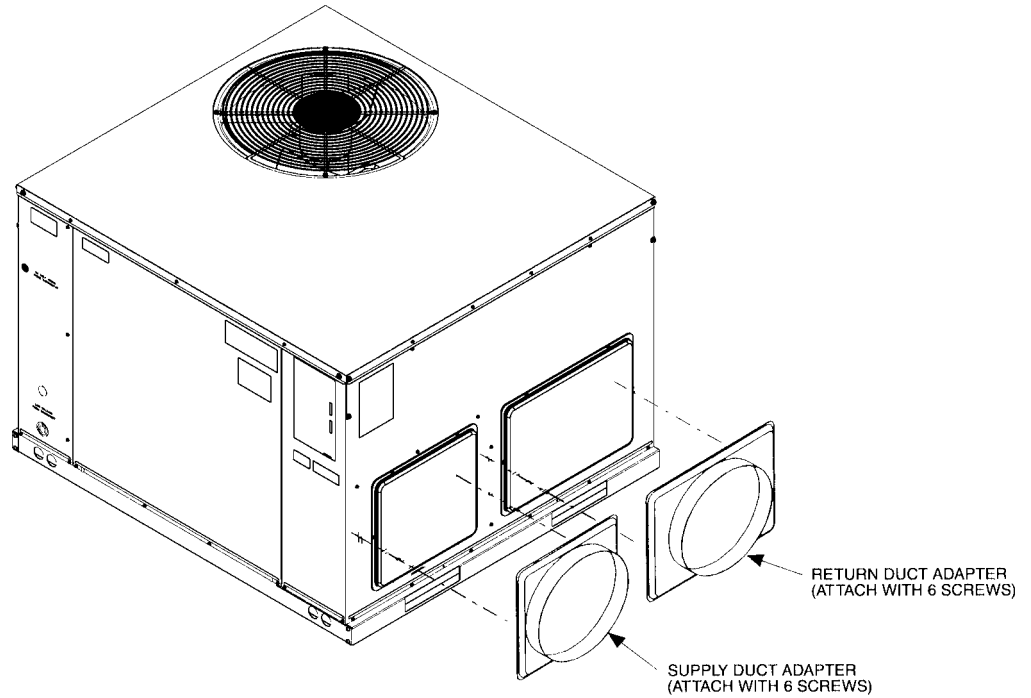

Roofcurb (Sloped) RXQG-AAA14 & RXQG-AAA24 for RQNL-B/RQPL-B Series

Note: Heat pump models must use sloped curbs.

Hinged corners make for fast, easy set-up.

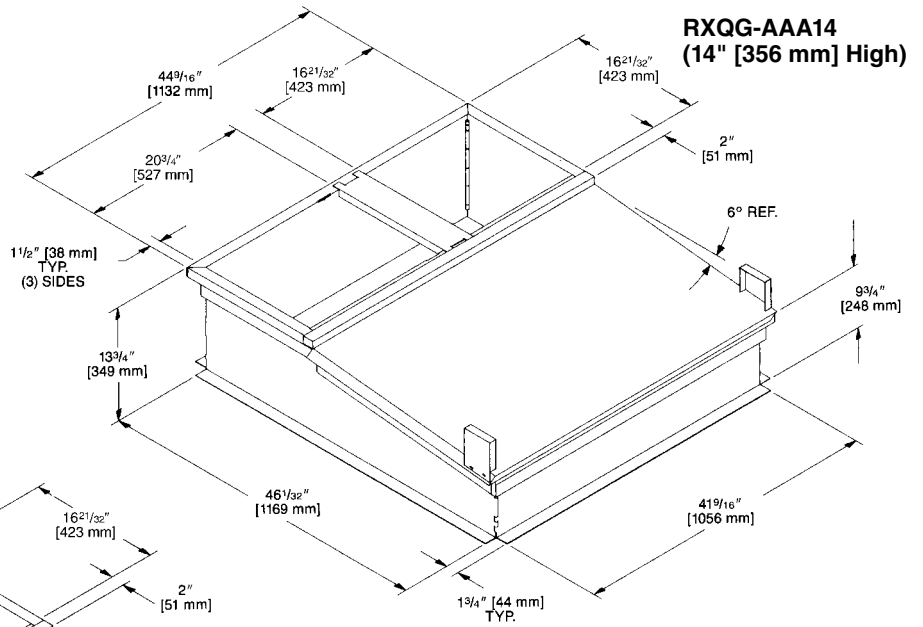

RXQG-AAA24 (24" [610 mm] High)

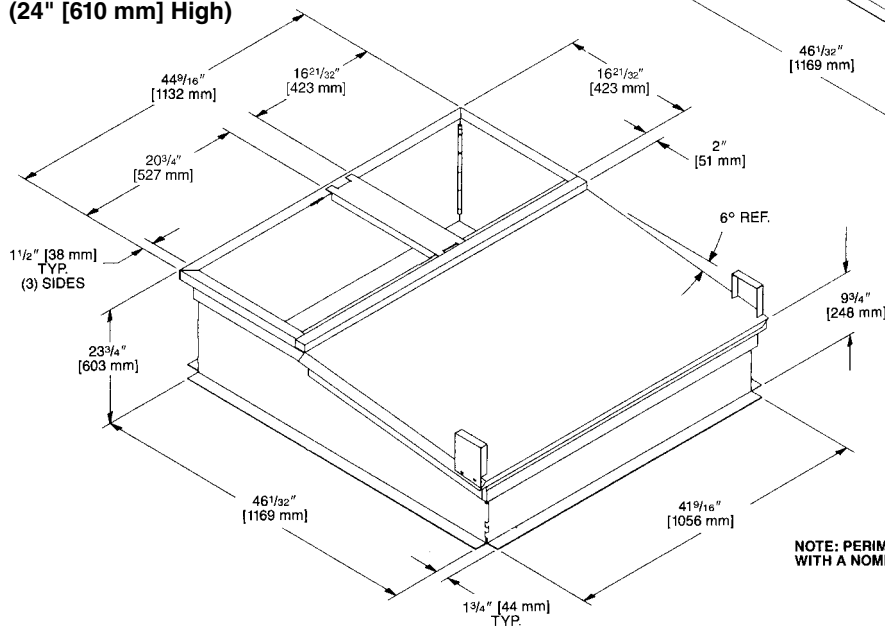

NOTE: PERIMETER OF ROOFCURB IS SUPPLIED WITH A NOMINAL 1" [25.4 mm] x 4" [102 mm] PINE NAILING STRIP.

Packaged Heat Pump Roofcurb Installation (Sloped)

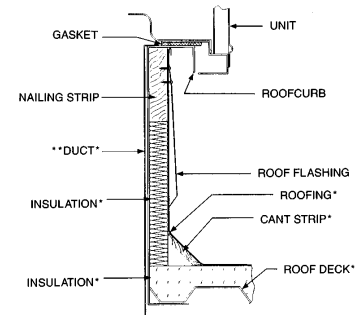
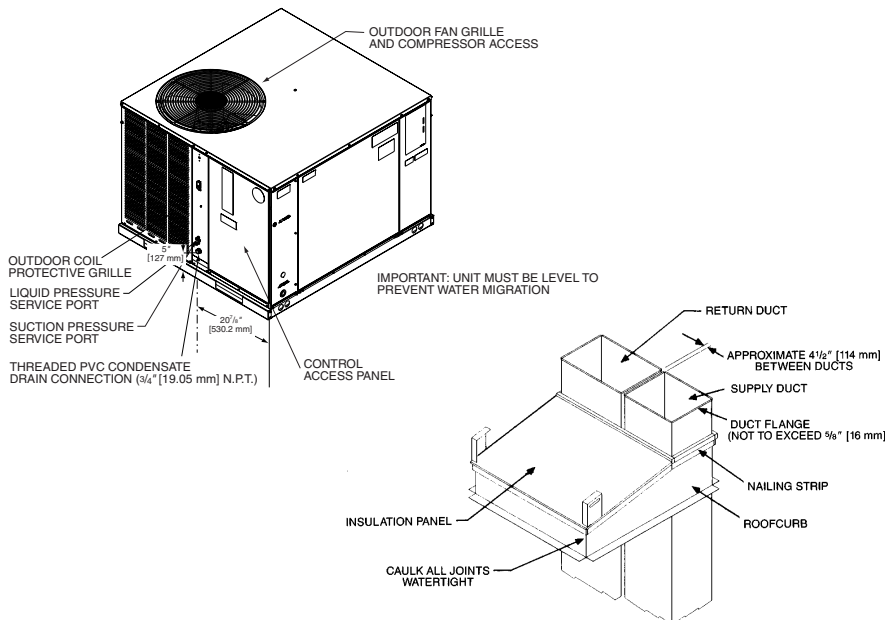

*BY CONTRACTOR
**FOR INSTALLATION OF DUCT AS SHOWN, USE RECOMMENDED DUCT SIZES FROM ROOFCURB INSTALLATION INSTRUCTIONS. FOR DUCT FLANGE AT ATTACHMENT TO UNIT, SEE UNIT INSTALLATION INSTRUCTIONS FOR RECOMMENDED DUCT SIZES.

[] Designates Metric Conversions

ROOFCURB ADAPTERS

Fabricated from galvanized steel to adapt the New cabinet to the old style curb. All are furnished with a New gasket.

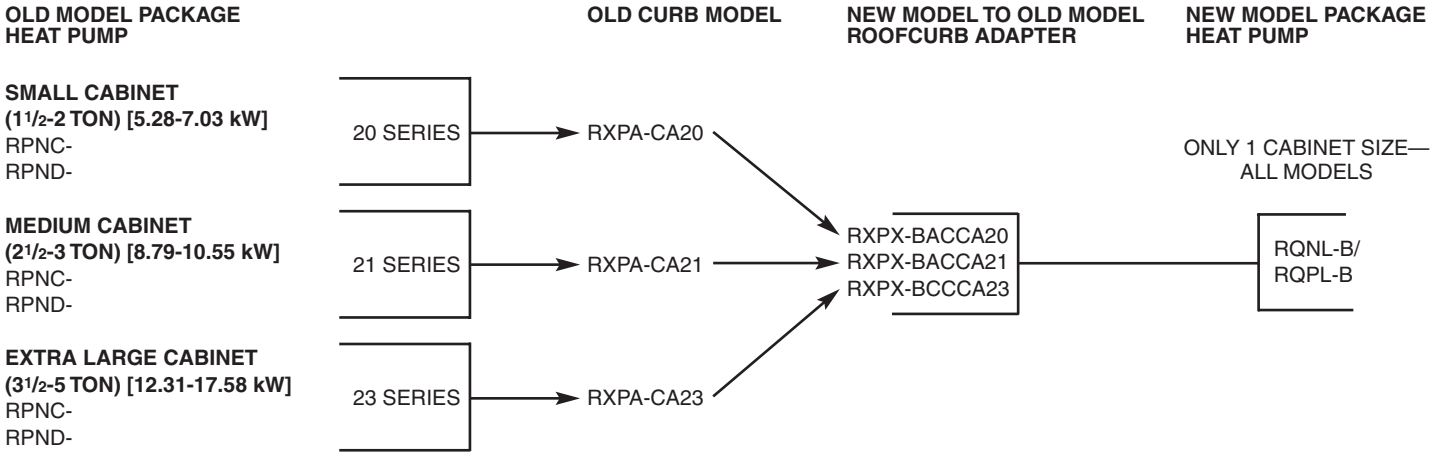

[] Designates Metric Conversions

LIFT KIT—MODEL NO. RXML-A01

The lift kit is intended for temporary installation while the unit is being lifted into position. Kit includes 4 lift brackets.

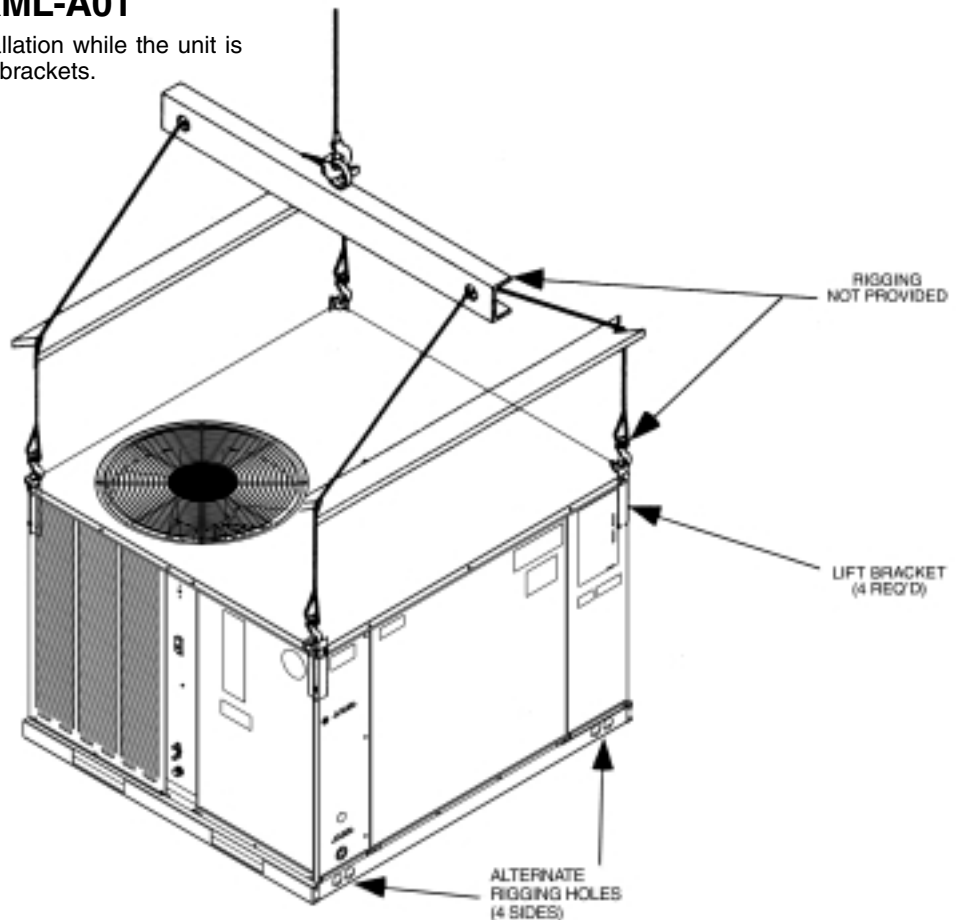

SCHEMATIC DIAGRAM

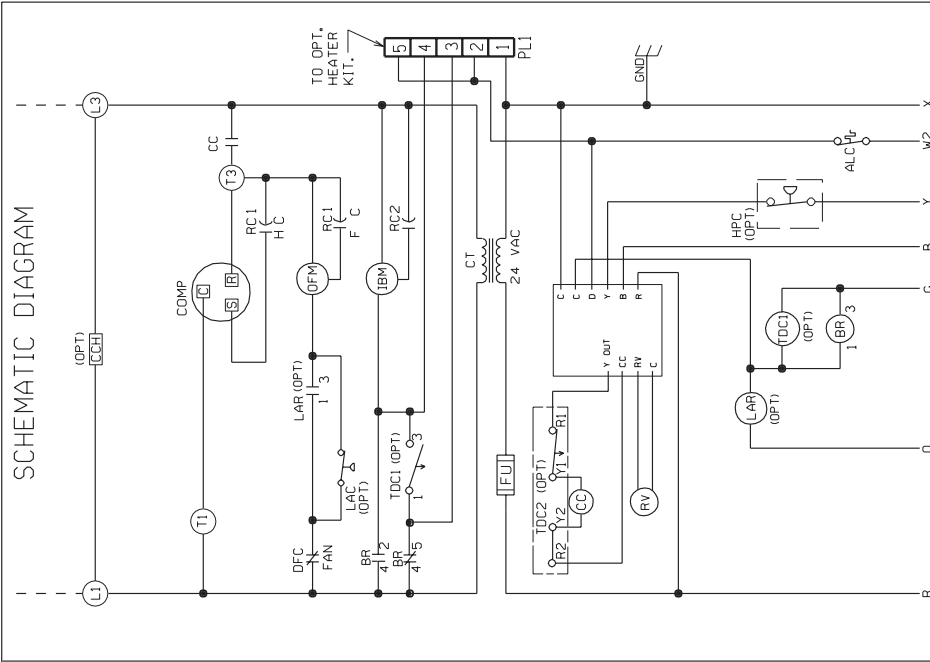

MODEL	FACTORY BLOWER SPEED
2.0 TON	HIGH
2.5 TON	LOW
3.0 TON	HIGH

WIRING DIAGRAM

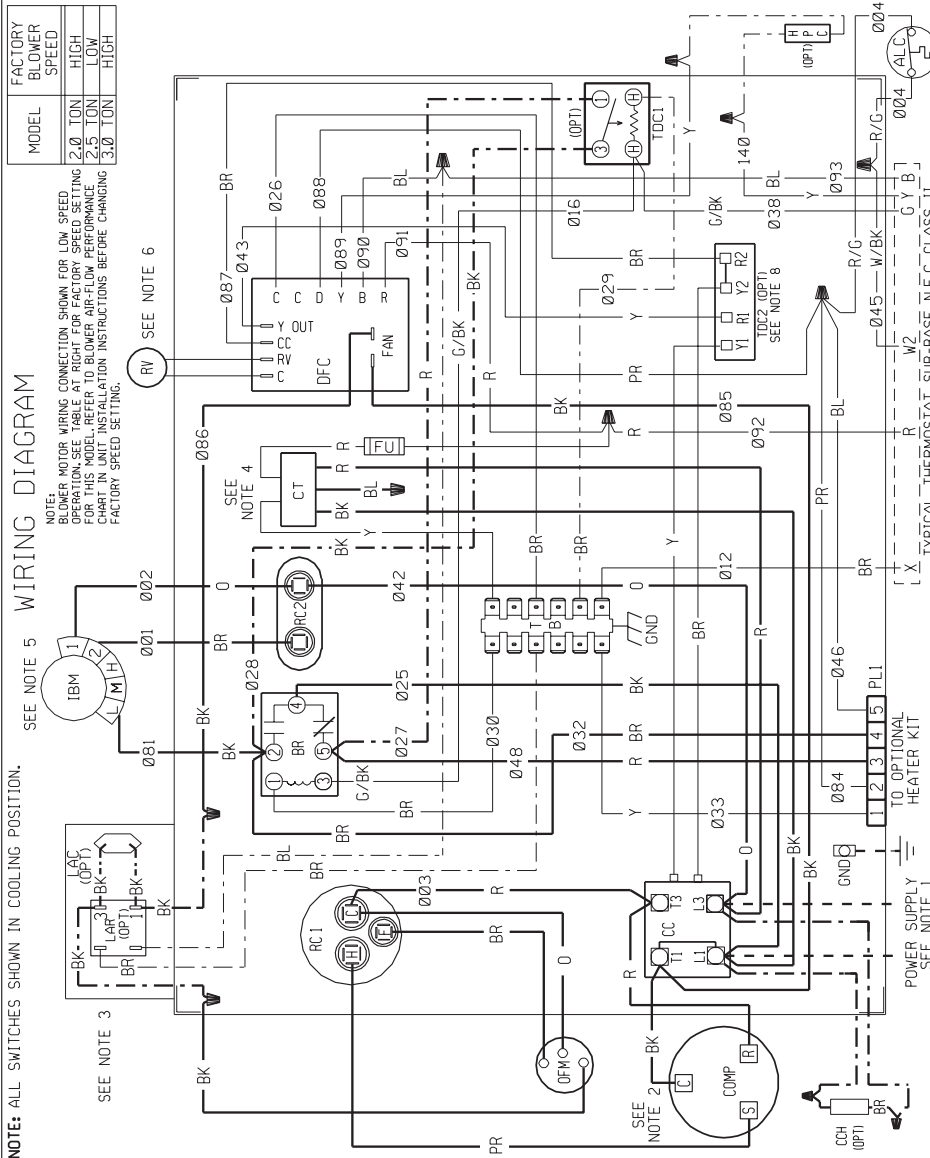

NOTE: ALL SWITCHES SHOWN IN COOLING POSITION.

SEE NOTE 5

NOTE: BLOWER MOTOR WIRING CONNECTION SHOWN FOR LOW SPEED OPERATION. FOR THIS MODEL, REFER TO BLOWER AIR-FLOW PERFORMANCE CHART IN UNIT INSTALLATION INSTRUCTIONS BEFORE CHANGING FACTORY SPEED SETTING.

SEE NOTE 6

SEE NOTE 2

SEE NOTE 4

SEE NOTE 8

WIRE COLOR CODE

BK	BLACK
BR	BROWN
BL	BLUE
G	GREEN
GY	GRAY
O	ORANGE
PR	PURPLE
R	RED
W	WHITE
Y	YELLOW

ELECTRICAL WIRING DIAGRAM

PACKAGE HEAT PUMP
1 PH, 208-230 VOLT
PSC INDOOR BLOWER MOTOR

WIRING INFORMATION

LINE VOLTAGE
 -FACTORY STANDARD
 -FACTORY OPTION
 -FIELD INSTALLED

LOW VOLTAGE
 -FACTORY STANDARD
 -FACTORY OPTION
 -FIELD INSTALLED

REPLACEMENT WIRE
 -MUST BE THE SAME SIZE AND TYPE OF INSULATION AS ORIGINAL (105 C MIN.)
 -CABINET MUST BE PERMANENTLY GROUNDED AND CONFORM TO I.E.C., N.E.C., C.E.C. AND LOCAL CODES AS APPLICABLE.

- ### NOTES:
- CONNECTORS SUITABLE FOR USE WITH COPPER CONDUCTORS ONLY.
 - COMPRESSOR MOTOR THERMALLY PROTECTED.
 - IF LAC/LAR IS NOT USED, CONNECT BLACK WIRE FROM OFM TO WIRE NUT FROM DR
 - TRANSFORMER-FACTORY WIRED FOR 230 VOLTS, USE RED AND BLUE LEADS FOR 208 VOLTS.
 - MOTOR FACTORY WIRED FOR CORRECT SPEED.
 - THIS COMPONENT ENERGIZED IN HEATING.
 - SEE FUSE LABEL ON CONTROL BOX COVER FOR FUSE SIZING AND CLASSIFICATION.
 - BROWN & YELLOW WIRES ARE CONTINUOUS IF OPTIONAL TDC IS NOT PRESENT.

COMPONENT CODE

ALC	AUX LIMIT CONTROL
BR	BLOWER RELAY
CC	COMPRESSOR CONTACTOR
CH	CRANKCASE HEATER
CCM	COMPRESSOR CONTROL TRANSFORMER
CT	DEFROST CONTROL
DFC	FUSE
FU	GROUND
GV	HIGH PRESSURE CONTROL
HPC	INDOOR BLOWER MOTOR
IBM	INDOOR BLOWER MOTOR
LAC	LOW AMBIENT COOLING CONTROL
LAR	LOW AMBIENT RELAY
OC	OUTDOOR FAN MOTOR
OPT	OPTIONAL
PL	PLUG
RC	RUN CAPACITOR
RV	REVERSING VALVE
TB	TERMINAL BLOCK
TDC	TIME DELAY CONTROL
W	WIRE NUT

90-23621-12 03

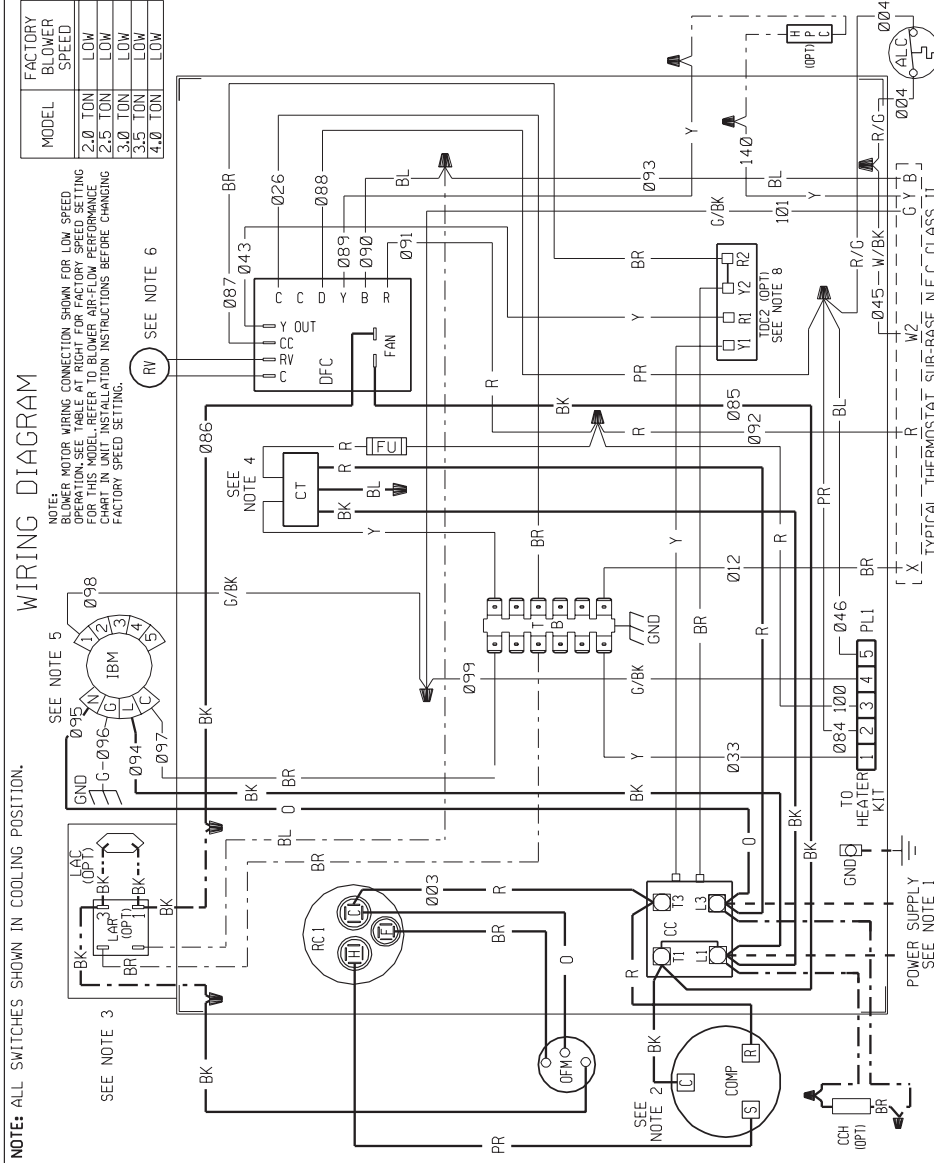
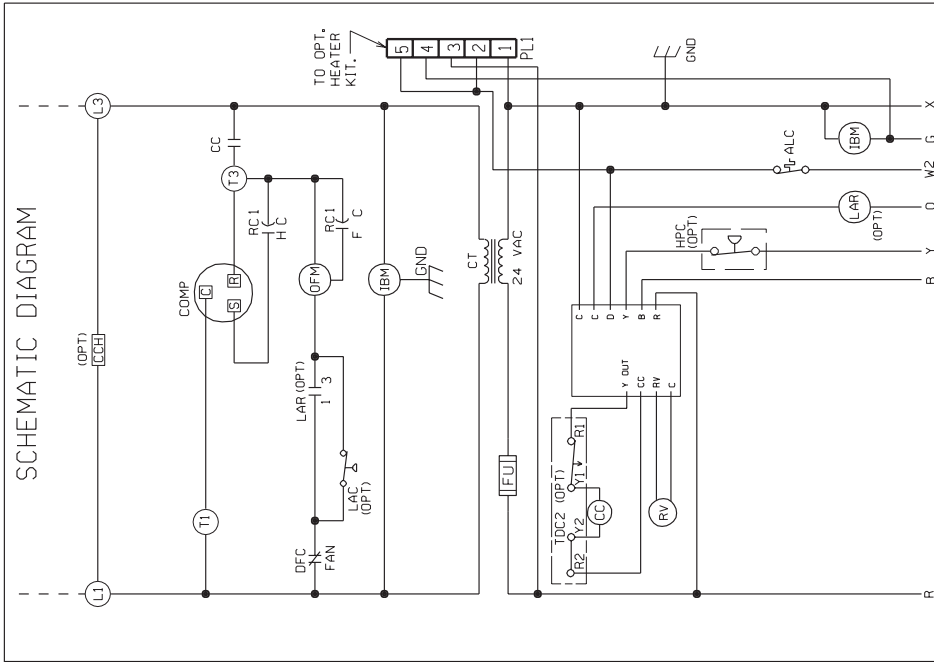

MODEL	FACTORY BLOWER SPEED
2.0 TON	LOW
2.5 TON	LOW
3.0 TON	LOW
3.5 TON	LOW
4.0 TON	LOW

NOTE: BLOWER MOTOR WIRING CONNECTION SHOWN FOR LOW SPEED OPERATION. SEE TABLE AT RIGHT FOR FACTORY SPEED SETTING. FOR THIS MODEL, REFER TO BLOWER AIR-FLOW PERFORMANCE INFORMATION IN THE INSTALLATION INSTRUCTIONS BEFORE CHANGING FACTORY SPEED SETTING.

NOTE: ALL SWITCHES SHOWN IN COOLING POSITION.

WIRE COLOR CODE
BK...BLACK
BR...BROWN
BL...BLUE
R...RED
W...WHITE
Y...YELLOW
GY...GRAY

WIRING INFORMATION

LINE VOLTAGE
 -FACTORY STANDARD
 -FACTORY OPTION
 -FIELD INSTALLED

LOW VOLTAGE
 -FACTORY STANDARD
 -FACTORY OPTION
 -FIELD INSTALLED

REPLACEMENT WIRE
 -MUST BE THE SAME SIZE AND TYPE OF INSULATION AS ORIGINAL (105 C MIN.)

WARNING
 -CABINET MUST BE PERMANENTLY GROUNDED AND CONFORM TO I.E.C., N.E.C., C.E.C. AND LOCAL CODES AS APPLICABLE.

NOTES:

- CONNECTORS SUITABLE FOR USE WITH COPPER CONDUCTORS ONLY.
- COMPRESSOR MOTOR THERMALLY PROTECTED.
- IF LAC/LAR IS NOT USED, CONNECT BLACK WIRE FROM OFM TO WIRE NUT FROM DR
- TRANSFORMER FACTORY WIRED FOR 230 VOLTS. USE RED AND BLUE LEADS FOR 208 VOLTS.
- MOTOR FACTORY WIRED FOR CORRECT SPEED.
- THIS COMPONENT ENERGIZED IN HEATING.
- SEE FUSE LABEL ON CONTROL BOX COVER FOR FUSE SIZING AND CLASSIFICATION.
- BROWN & YELLOW WIRES ARE CONTINUOUS IF OPTIONAL TDC2 IS NOT PRESENT.

COMPONENT CODE	DESCRIPTION
ALC	AUX. LIMIT CONTROL
BR	BLOWER RELAY
CC	COMPRESSOR CONTACTOR
CCH	CRANKCASE HEATER
COMP	COMPRESSOR TRANSFORMER
DFC	DEFROST CONTROL
FUSE	RUN CAPACITOR
IBM	INDOOR BLOWER MOTOR
LAC	LOW AMBIENT COOLING CONTROL
LAR	LOW AMBIENT RELAY
OFM	OUTDOOR FAN MOTOR
OPT	OPTIONAL
RC	REVERSING VALVE
RC1	TERMINAL BLOCK
RC2	TIME DELAY CONTROL
RV	WIRE NUT
T1	INDOOR BLOWER MOTOR
TDC	HIGH PRESSURE CONTROL
TDC2	INDOOR BLOWER MOTOR

DWG. NO. 90-23621-13 REV 04

ELECTRICAL WIRING DIAGRAM

PACKAGE HEAT PUMP

1 PH, 208-230 VOLT
 X-13 INDOOR BLOWER MOTOR

DR. BY KDF
 APP. BY KDF
 DATE 03-15-05
 DWG. NO. 90-23621-13
 REV 04

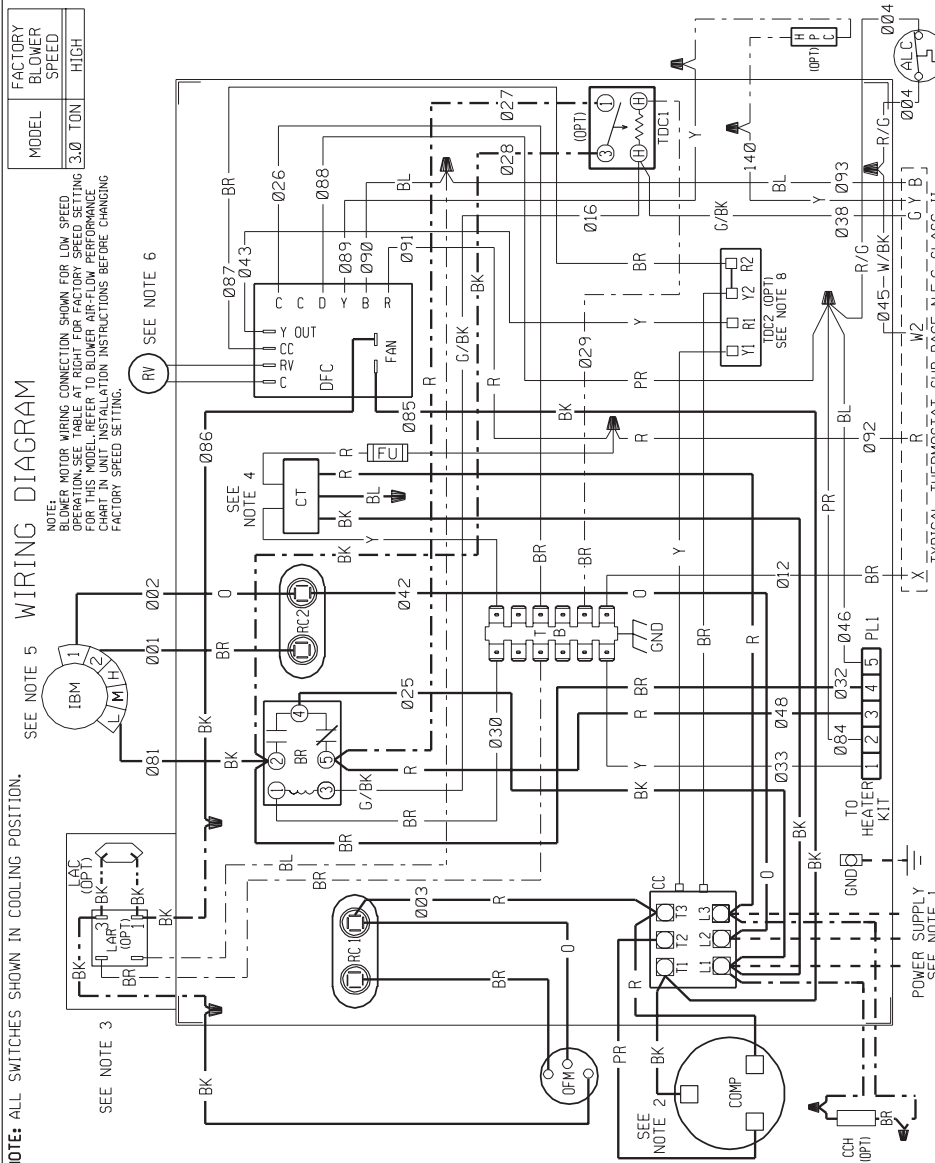
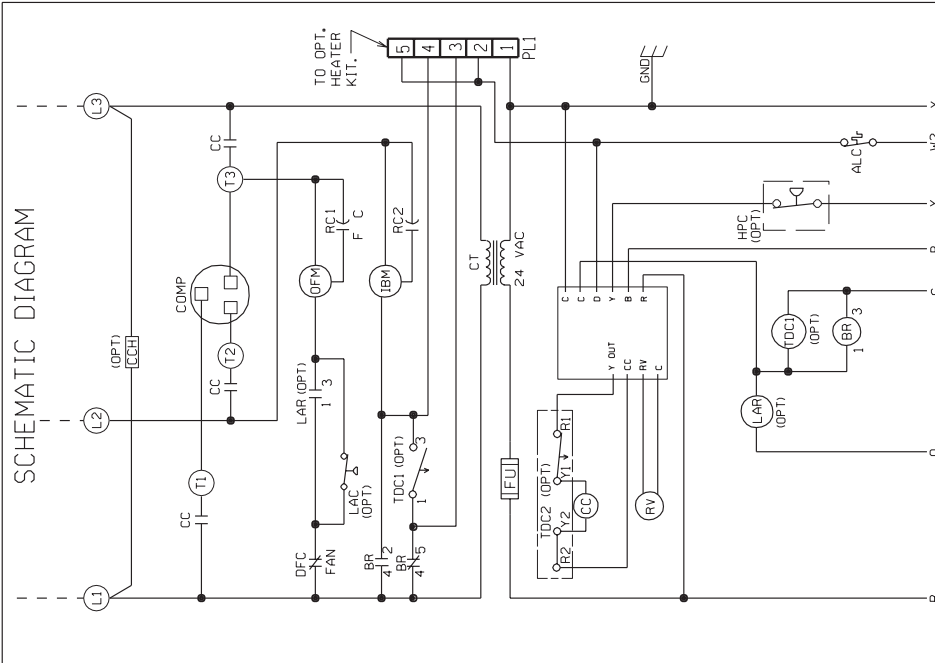

MODEL	FACTORY BLOWER SPEED
3.0 TON	HIGH

NOTE: BLOWER MOTOR WIRING CONNECTION SHOWN FOR LOW SPEED OPERATION. SEE TABLE AT RIGHT FOR FACTORY SPEED SETTING FOR THIS MODEL. REFER TO BLOWER AIR-FLOW PERFORMANCE CHART IN UNIT INSTALLATION INSTRUCTIONS BEFORE CHANGING FACTORY SPEED SETTING.

SEE NOTE 5

NOTE: ALL SWITCHES SHOWN IN COOLING POSITION.

WIRE COLOR CODE	
BK	BLACK
BR	BROWN
BL	BLUE
G	GREEN
GY	GRAY
O	ORANGE
PR	PURPLE
R	RED
W	WHITE
Y	YELLOW

ELECTRICAL WIRING DIAGRAM	
PACKAGE HEAT PUMP	
3 PH, 208-230 VOLT	
PSC INDOOR BLOWER MOTOR	
DR. BY	KDF
APP. BY	DATE
DWG. NO.	90-23621-14
REV	04

WIRING INFORMATION	
LINE VOLTAGE	STANDARD
-FACTORY OPTION	FIELD INSTALLED
LOW VOLTAGE	-FACTORY STANDARD
-FACTORY OPTION	-FIELD INSTALLED
REPLACEMENT WIRE	MUST BE THE SAME SIZE AND TYPE OF INSULATION AS ORIGINAL (105 C° MIN.)
-CABINET MUST BE PERMANENTLY GROUNDED AND CONFORM TO I.E.C., N.E.C., C.E.C. AND LOCAL CODES AS APPLICABLE.	

NOTES:	
1.	CONNECTORS SUITABLE FOR USE WITH COPPER CONDUCTORS ONLY.
2.	COMPRESSOR MOTOR THERMALLY PROTECTED.
3.	IF LAC/LAR IS NOT USED, CONNECT BLACK WIRE FROM OFM TO WIRE NUT FROM DR
4.	TRANSFORMER FACTORY WIRED FOR 230 VOLTS. USE RED AND BLUE LEADS FOR 208 VOLTS.
5.	MOTOR FACTORY WIRED FOR CORRECT SPEED.
6.	THIS COMPONENT ENERGIZED IN HEATING.
7.	SEE FUSE LABEL ON CONTROL BOX COVER FOR FUSE SIZING AND CLASSIFICATION.
8.	BROWN & YELLOW WIRES ARE CONTINUOUS IF OPTIONAL TDC2 IS NOT PRESENT.

COMPONENT CODE	
ALC	AUX. LIMIT CONTROL
BR	BLOWER RELAY CONTACTOR
CC	COMPRESSOR-HEATER
CC	COMPRESSOR
CC	CONTROL TRANSFORMER
CC	DEFROST CONTROL
CC	FUSE
CC	GROUND
CC	HIGH PRESSURE CONTROL
CC	INDOOR BLOWER MOTOR
CC	LOW AMBIENT COOLING
CC	CONTROL RELAY
CC	OUTDOOR FAN MOTOR
CC	OPTIONAL PLUG
CC	RUN CAPACITOR
CC	REVERSING VALVE
CC	TERMINAL BLOCK
CC	TIME DELAY CONTROL
CC	WIRE NUT

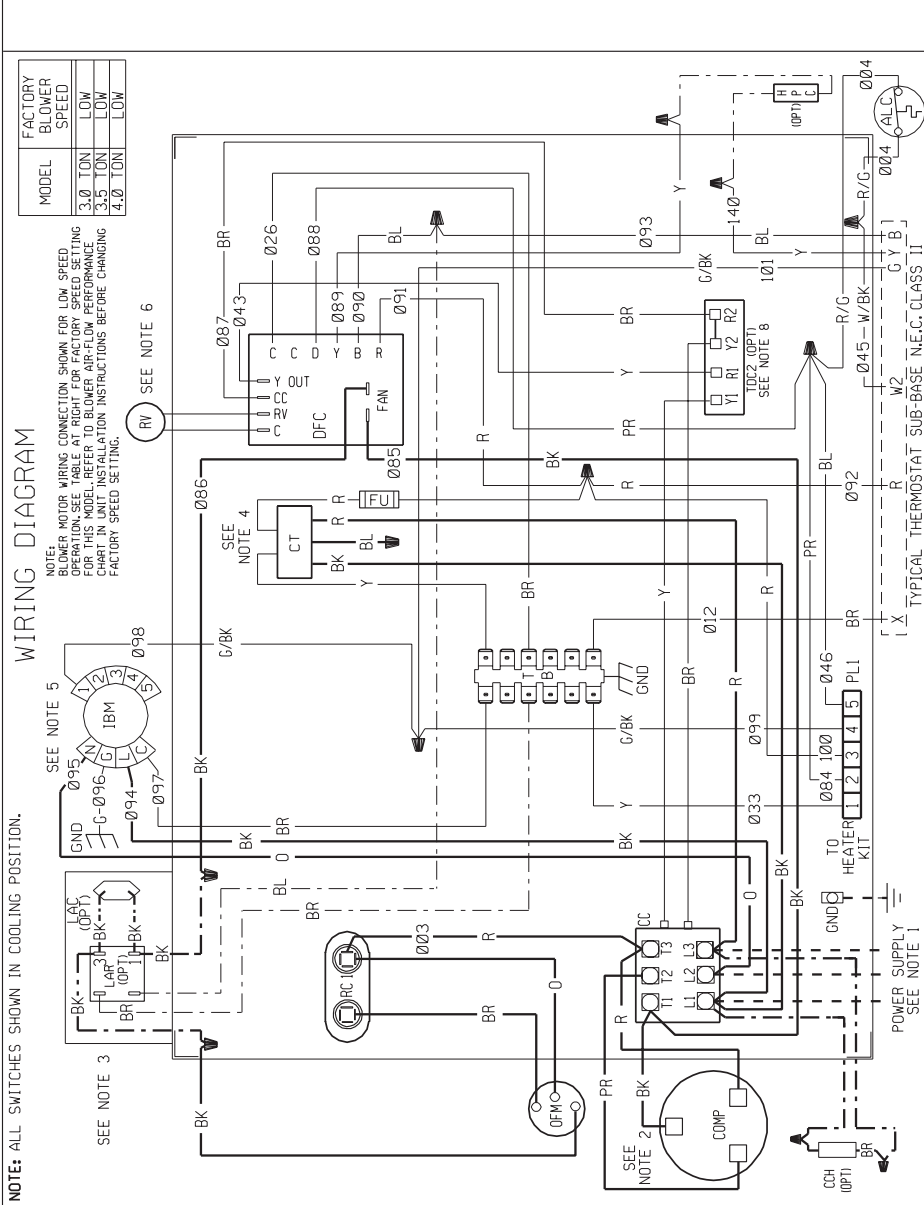
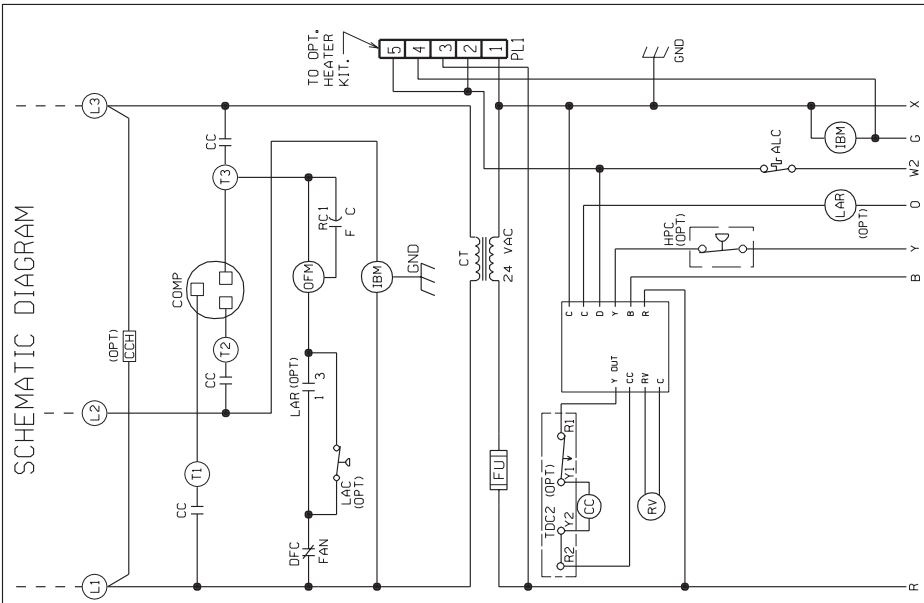

MODEL	FACTORY BLOWER SPEED
3.0 TON	LOW
3.5 TON	LOW
4.0 TON	LOW

NOTE: MOTOR WIRING CONNECTION SHOWN FOR LOW SPEED OPERATION. REFER TO BLOWER AIR-FLOW PERFORMANCE CHART IN UNIT INSTALLATION INSTRUCTIONS BEFORE CHANGING FACTORY SPEED SETTING.

NOTE: ALL SWITCHES SHOWN IN COOLING POSITION.

WIRE COLOR CODE

BK	BLACK
BR	BROWN
BL	BLUE
G	GREEN
GY	GRAY
OR	ORANGE
PR	PURPLE
R	RED
W	WHITE
Y	YELLOW

ELECTRICAL WIRING DIAGRAM

PACKAGE HEAT PUMP
3 PH, 208-230 VOLT
X-13 INDOOR BLOWER MOTOR

WIRING INFORMATION

LINE VOLTAGE
-FACTORY STANDARD
-FACTORY OPTION
-FIELD INSTALLED

LOW VOLTAGE
-FACTORY STANDARD
-FIELD INSTALLED

REPLACEMENT WIRE
-MUST BE THE SAME SIZE AND TYPE OF INSULATION AS ORIGINAL (105 C MIN.)
-CABINET MUST BE PERMANENTLY GROUNDED AND CONFORM TO I.E.C., N.E.C., C.E.C. AND LOCAL CODES AS APPLICABLE.

- ### NOTES:
- CONNECTORS SUITABLE FOR USE WITH COPPER CONDUCTORS ONLY.
 - COMPRESSOR MOTOR THERMALLY PROTECTED.
 - IF LAC/LAR IS NOT USED, CONNECT BLACK WIRE FROM OFM TO WIRE NOT FROM DR
 - TRANSFORMER FACTORY WIRED FOR 230 VOLTS. USE RED AND BLUE LEADS FOR 208 VOLTS.
 - MOTOR FACTORY WIRED FOR CORRECT SPEED.
 - THIS COMPONENT ENERGIZED IN HEATING.
 - SEE FUSE LABEL ON CONTROL BOX COVER FOR FUSE SIZING AND CLASSIFICATION.
 - BROWN & YELLOW WIRES ARE CONTINUOUS IF OPTIONAL TOCC2 IS NOT PRESENT.

COMPONENT CODE

ALC	AUX LIMIT CONTROL
BC	BLOWER RELAY CONTACTOR
CC	COMPRESSOR HEATER
CCM	CRANKCASE HEATER
CT	CONTROL TRANSFORMER
CT	CONTROL TRANSFORMER
DFC	DEFROST CONTROL
FUSE	FUSE
GN	GROUND
HPC	HIGH PRESSURE CONTROL
IBM	INDOOR BLOWER MOTOR
LAC	LOW AMBIENT COOLING
LAR	CONTROL RELAY
OFM	LOW AMBIENT OUTDOOR FAN MOTOR
OPT	OPTIONAL
PL	PLUG
RC	RUN CAPACITOR
RV	REVERSING VALVE
TB	TERMINAL BLOCK
TDC	TIME DELAY CONTROL WIRE NUT

DWG. NO.	90-23621-15	REV	04
DR. BY	DATE	APP. BY	DATE
KDF	03-15-05	KDF	03-15-05
DWG. NO.	90-23621-15	REV	04

BEFORE PURCHASING THIS APPLIANCE, READ IMPORTANT ENERGY COST AND EFFICIENCY INFORMATION AVAILABLE FROM YOUR RETAILER.

GENERAL TERMS OF LIMITED WARRANTY

ICECOSM will furnish a replacement for any part of this product which fails in normal use and service within the applicable periods stated, in accordance with the terms of the limited warranty.

For Complete Details of the Limited Warranty, Including Applicable Terms and Conditions, See Your Local Installer or Contact the Manufacturer for a Copy.

- Electric Heating Elements for Optional
- Electric Heating KitsFive (5) Years
- Compressor.....Five (5) Years
- 14 SEER 1-Phase Models
- (Residential Applications)Ten (10) Years
- 14 SEER 1 & 3-Phase Models
- (Commercial Applications).....Five (5) Years
- 13 SEER 1 & 3-Phase ModelsFive (5) Years
- Any Other Part
- 1-Phase Models
- (Residential Applications)Five (5) Years
- 1 & 3-Phase Models
- (Commercial Applications)One (1) Year

Before proceeding with installation, refer to installation instructions packaged with each model, as well as complying with all Federal, State, Provincial, and Local codes, regulations, and practices.

Manufactured By ICECO



5600 Old Greenwood Road, Fort Smith, Arkansas 72908



"In keeping with its policy of continuous progress and product improvement, ICECO reserves the right to make changes without notice."