



PACKAGE GAS / ELECTRIC ROOFTOP UNITS

FORM NO. R22-844 REV. 2
Supersedes Form No. R22-844 Rev. 1

Featuring Industry Standard R-410A Refrigerant

R-410A

**RKNL-C STANDARD EFFICIENCY SERIES
With ClearControl™**

**NOMINAL SIZES 15-25 TONS [52.8-87.9 kW]
ASHRAE 90.1-2007 COMPLIANT MODEL**



25 TON MODEL IS OUTSIDE THE
SCOPE OF AHRI STANDARD 340/360



Introduction	3
Unit Features & Benefits	4-8
Selection Procedure	9
Model Identification Options	10-11
General Data	
RKNL-C Series	12-23
General Data Notes	24
Performance Data	
RKNL-C Series	25-26
Airflow Performance	
RKNL-C Series	27-30
Electrical Data	
RKNL-C Series	31-33
Dimensional Data	34-37
Accessories	38-52
Mechanical Specifications	53-59
Typical Wiring	60-63
Limited Warranty	64

These quality features are included in the Ruud Package Gas/Electric Unit



STANDARD FEATURES INCLUDE:

- R-410A HFC refrigerant.
- Complete factory charged, wired and run tested.
- Scroll compressors with internal line break overload and high-pressure protection.
- Dual stage compressors.
- Convertible airflow – vertical downflow or horizontal sideflow.
- TXV refrigerant metering system on each circuit.
- High Pressure and Low Pressure/Loss of charge protection standard on all models.
- Solid Core liquid line filter drier on each circuit.
- Single slab, single pass designed evaporator and condenser coils facilitate easy cleaning for maintaining high efficiencies.
- Cooling operation up to 125 degree F ambient.
- Foil faced insulation encapsulated throughout entire unit minimizes airborne fibers from the air stream.
- Hinged major access door with heavy-duty gasketing, 1/4 turn latches and door retainers.
- Slide Out Indoor fan assembly for added service convenience.
- Powder Paint Finish meets ASTM B117 steel coated on each side for maximum protection. G90 galvanized.
- Base pan with drawn supply and return opening for superior water management.
- Forkable base rails for easy handling and lifting.
- Single point electrical connections.
- Internally sloped slide out condensate pan conforms to ASHRAE 62 standards.
- High performance belt drive motor with variable pitch pulleys and quick adjust belt system.
- Permanently lubricated evaporator, condenser and gas heat inducer motors.
- Condenser motors are internally protected, totally enclosed with shaft down design.
- 2 inch filter standard with slide out design.
- Two stage gas valve, direct spark ignition, and induced draft for efficiency and reliability.
- Tubular heat exchange for long life and induced draft for efficiency and reliability.
- Solid state furnace control with on board diagnostics.
- 24 volt control system with resettable circuit breakers.
- Colored and labeled wiring.
- Copper tube/Aluminum Fin coils.
- Factory Installed Direct Digital Control (DDC) and sensors which can connect to LonWorks™ or BACnet® BAS systems for remote monitoring and control.

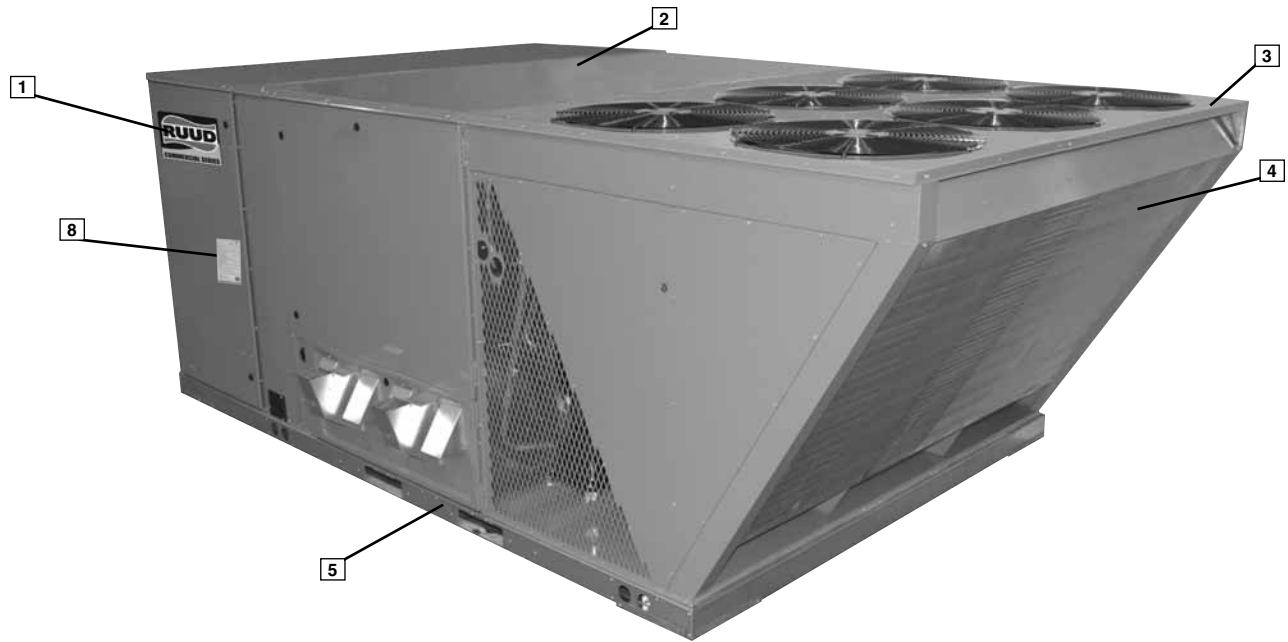

Ruud Package equipment is designed from the ground up with the latest features and benefits required to compete in today's market. The clean design stands alone in the industry and is a testament to the quality, reliability, ease of installation and serviceability that goes into each unit. Outwardly, the large Ruud *Commercial Series™* label (1) identifies the brand to the customer.

The sheet-metal cabinet (2) uses nothing less than 20-gauge material for structural components with an underlying coat of G90. To ensure the leak-proof integrity of these units, the design utilizes a top with a 1/8" drip lip (3), gasket-protected panels and screws. The slanted outdoor coil protects the coil from hail damage (4). Every Ruud package unit uses the toughest finish in the industry, using electro deposition baked-on enamel tested to withstand a rigorous 1000-hour salt spray test, per ASTM B117.

Anything built to last must start with the right foundation. In this case, the foundation is 14-gauge, commercial-grade, full-perimeter base rails (5), which integrate fork slots and rigging holes to save set-up time on the job site. The base pan is stamped, which forms a 1-1/8" flange around the supply and return opening and has eliminated the worry of water entering the conditioned space (6). The drainpan (7) is made of material that resists the growth of harmful bacteria and is sloped for the latest IAQ benefits. Furthermore, the drainpan slides out for easy cleaning. The insulation has been placed on the underside of the basepan, removing areas that would allow for potential moisture accumulation, which can facilitate growth of harmful bacteria. All insulation is secured with both adhesive and mechanical fasteners, and all edges are hidden.

During development, each unit was tested to U.L. 1995, ANSI 21.47, AHRI 340-360 and other Ruud-required reliability tests. Ruud adheres to stringent ISO 9002 quality procedures, and each unit bears the U.L. and AHRI certification labels located on the unit nameplate (8). Contractors can rest assured that when a Ruud package unit arrives at the job, it is ready to go with a factory charge and quality checks.

Access to all major compartments is from the front of the unit, including the filter and electrical compartment, blower compartment, furnace section, and outdoor section. Each panel is permanently embossed with the compartment name (control/filter access, blower access and furnace access).

Electrical and filter compartment access is through a large, tool-less, hinged-access panel with 1/4 turn latches. On the outside of the panel is the unit nameplate, which contains the model and serial number, electrical data and other important unit information.

The unit charging chart is located on the inside of the electrical and filter compartment door. Electrical wiring diagrams are found on the control box cover, which allows contractors to move them to more readable locations. To the right of the control box the model and serial number can be found. Having this information on the inside will assure model identification for the life of the product. The production line quality test assurance label is also placed in this location (9). The two-inch throwaway filters (10) are easily removed on a tracked system for easy replacement.

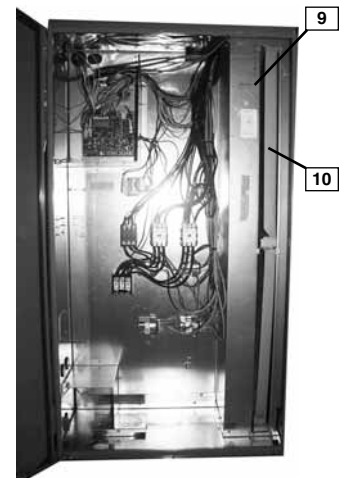
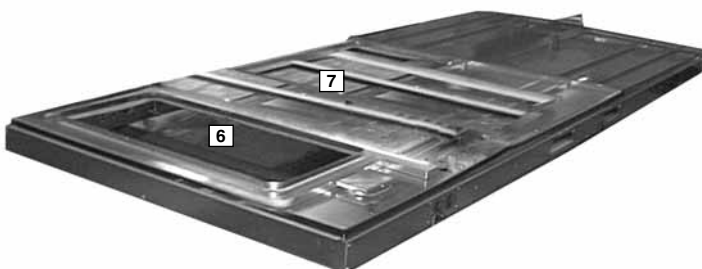

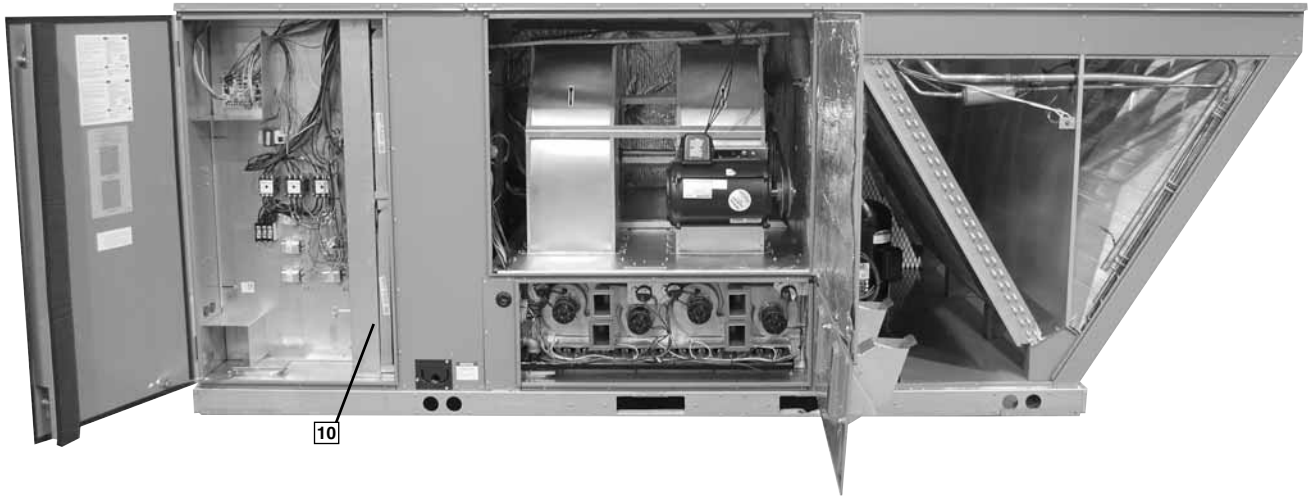

Inside the control box (10), each electrical component is clearly identified with a label that matches the component to the wire diagram for ease of trouble shooting. All wiring is numbered on each end of the termination and color-coded to match the wiring diagram. The integrated furnace control, used to control furnace operation, incorporates a flashing LED troubleshooting device. Flash codes are clearly outlined on the unit wiring diagram. The control transformer has a low voltage circuit breaker that trips if a low voltage electrical short occurs. There is a blower contactor and compressor contactor for each compressor.

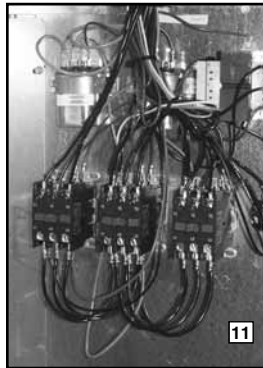

As part of the ClearControl™ system which allows real time monitoring and communication between rooftop units, the RKNL-C Package Heat Pump has a Rooftop Unit Controller (RTU-C) factory mounted and wired in the control panel. The RTU-C is a solid-state microprocessor-based control board that provides flexible control and extensive diagnostics for all unit functions. The RTU-C through proportional/integral control algorithms perform specific unit functions that govern unit operation in response to: zone conditions, system temperatures, system pressures, ambient conditions and electrical inputs. The RTU-C features a 16 x 2 character LCD display and a five-button keypad for local configuration and direct diagnosis of the system. New features include a clogged filter switch (CFS), fan proving switch (FPS), return air temperature sensor (RAT), discharge air temperature sensor (DAT) and outdoor air temperature sensor (OAT). Freeze sensors (FS) are used in place of freezestats to allow measurement of refrigerant suction line temperatures. The RKNL-C Package Gas/Electric with ClearControl™ is specifically designed to be applied in four distinct applications:

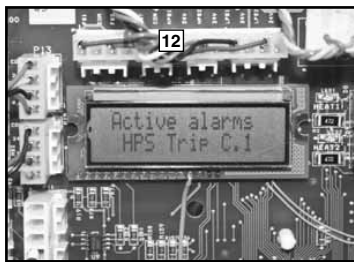

The RKNL-C is compatible with a third party building management system that supports the BACnet Application Specific Controller device profile, with the use of a field installed BACnet Communication Module. The BACnet Communication Module plugs onto the unit RTU-C controller and allows communication between ClearControl™ and the BACnet MSTP network. A zone sensor, a BACnet network zone sensor, a BACnet thermostat or DDC controller may be used to send the zone temperature or thermostat demands to the RTU-C. The BACnet Communication Module is compatible with MSTP EIA-485 daisy chain networks communicating at 38.4 bps. It is compatible with twisted pair, shielded cables.

The RKNL-C is compatible with a third party building management system that supports the LonMark Space Comfort Controller (SCC) functional profile or LonMark Discharge Air Controller (DAC) functional profile. This is accomplished with a field installed LonMark communication module. The LonMark Communication Module plugs onto the RTU-C controller and allows communication between ClearControl™ and a LonWorks Network. A zone sensor, a LonTalk network zone sensor, or a LonTalk thermostat or DDC controller may be used to send the zone temperature or thermostat demands to the RTU-C. The LonMark Communication Module utilizes an FTT-10A free topology transceiver communicating at 78.8 kbps. It is compatible with Echelon qualified twisted pair cable, Belden 8471 or NEMA Level 4 cables. The Module can communicate up to 1640 ft. with no repeater. The LonWorks limit of 64 nodes per segment applies to this device.

The RKNL-C is compatible with a programmable 24 volt thermostat. Connections are made via conventional thermostat screw terminals. Extensive unit status and diagnostics are displayed on the LCD screen of the RTU-C.

The RKNL-C is compatible with a zone sensor and mechanical or solid state time clock connected to the RTU-C. Extensive unit status and diagnostics are displayed on the LCD screen of the RTU-C.

A factory or field installed Comfort Alert® module is available for power phase-monitoring protection and additional compressor diagnostics. The alarms can be displayed on the RTU-C display, through the (BAS) network, or connected to the "L-Terminal" of a thermostat for notification.

For added convenience in the field, a factory-installed convenience outlet and disconnect (13) are available. Low and High voltage can enter either from the side or through the base. Low-voltage connections are made through the low-voltage terminal strip. For ease of access, the U.L.-required low voltage barrier can be temporarily removed for low-voltage termination and then reinstalled. The high-voltage connection is terminated at the high-voltage terminal block. The suggested mounting for the field-installed disconnect is on the exterior side of the electrical control box.



In the outdoor section are the external gauge ports. (14). With gauge ports mounted externally, an accurate diagnostic of system operation can be performed quickly and easily.



The blower compartment is to the right of the control box and can be accessed by 1/4 turn latches. To allow easy maintenance of the blower assembly, the entire assembly easily slides out by removing

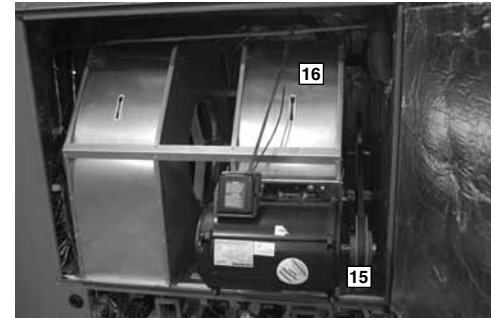

four #10 screws from the blower assembly. The adjustable motor pulley (15) can easily be adjusted by loosening the bolts on either side of the motor mount. Removing the bolts allows for easy removal of the blower pulley by pushing the blower assembly up to loosen the belt. Once the belt is removed, the motor sheave can be adjusted to the desired number of turns, ranging from 1 to 6 turns open. Where the demands for the job require high static, Ruud has high-static drives available that deliver nominal airflow up to 2" of static. By referring to the airflow performance tables listed in the installation instructions, proper static pressure and CFM requirements can be dialed in. The scroll housing (16) and blower scroll provide quiet and efficient airflow. The blower sheave is secured by an "H" bushing which firmly secures the pulley to the blower shaft for years of trouble-free operation. The "H" bushing allows for easy removal of the blower pulley from the shaft, as opposed to the use of a set screw, which can score the shaft, creating burrs that make blower-pulley removal difficult.

Also inside the blower compartment are the optional low-ambient controls (17). The low-ambient controls allow for operation of the compressor down to 0 degrees ambient temperature by cycling the outdoor fans on high pressure. Use of polarized plugs and schrader fittings allow for easy field or factory installation. The freeze sensor clips on the suction line near the evaporator outlet. The freeze sensor protects the compressor if the evaporator coil gets too cold (below freezing) due to low airflow and allows monitoring of the suction line temperature on the controller display.



Inside the blower compartment the interlaced evaporator can also be viewed. The evaporator uses enhanced fin technology for maximum heat transfer. The TXV metering device assures even distribution of refrigerant throughout the evaporator.

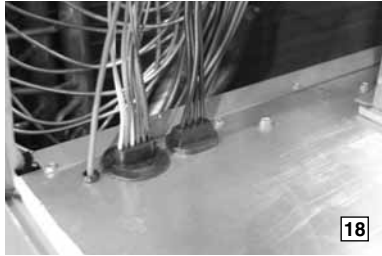

Wiring throughout the unit is neatly bundled and routed. Where wire harnesses go through the condenser bulkhead or blower deck, a molded wire harness assembly (18) provides an air-tight and water-tight seal, and provides strain relief. Care is also taken to tuck raw edges of insulation behind sheet metal to improve indoor air quality.

The furnace compartment contains the latest furnace technology on the market. The draft inducers (19) draw the flame from the Ruud exclusive in-shot burners (20) into the aluminized tubular heat exchanger (21) for clean, efficient gas heat. Stainless steel heat exchangers can be factory installed for those applications that have high fresh-air requirements, or applications in corrosive environments. Each furnace is equipped with a two-stage gas valve (22), which provides two stages of gas heat input. The first stage operates at 50% of the second stage (full fire). 81% steady state efficiency is maintained on both first and second stage by staging the multiple inducers to optimize the combustion airflow and maintain a near stoichiometric burn at each stage.



The direct spark igniter (23) assures reliable ignition in the most adverse conditions. This is coupled with remote flame sense (24) to assure that the flame has carried across the entire length of the burner assembly. Gas supply can be routed from the side or up through the base.

Each furnace has the following safety devices to assure consistent and reliable operation after ignition:

- Pressures switches (25) to assure adequate combustion airflow before ignition.
- Rollout switches (26) to assure no obstruction or cracks in the heat exchanger.
- A limit device that protects the furnace from over-temperature problems.

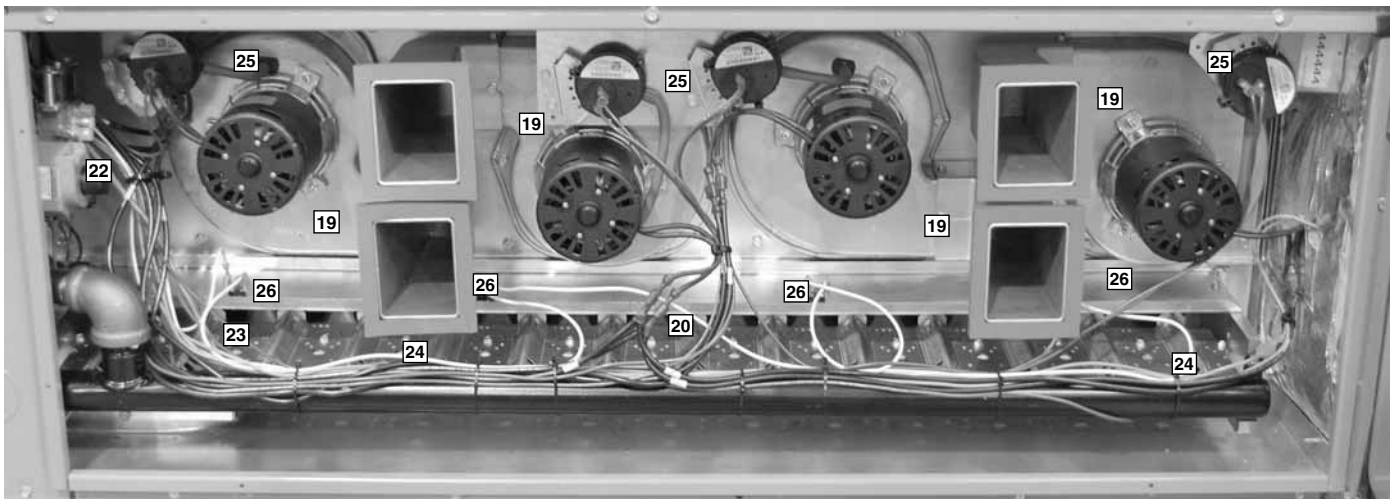

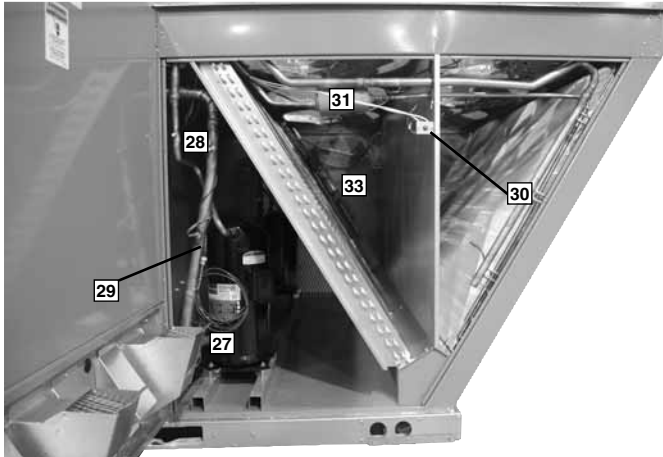

The compressor compartment houses the heartbeat of the unit. The scroll compressor (27) is known for its long life, and for reliable, quiet, and efficient operation. The suction and discharge lines are designed with shock loops (28) to absorb the strain and stress that the starting torque, steady state operation, and shut down cycle impose on the refrigerant tubing. Each compressor and circuit is independent for built-in redundancy, and each circuit is clearly marked throughout the system. Each unit has two stages of efficient cooling operation, first stage is approximately 50% of second stage.

The low-pressure switches (29) and high-pressure switches (30) are mounted on the appropriate refrigerant lines in the condenser section. The high-pressure switch will shut off the compressors if pressures exceeding 610 PSIG are detected as may occur if the outdoor fan motor fails. The low-pressure switches shut off the compressors if low pressure is detected due to loss of refrigerant charge. Each factory-installed option is brazed into the appropriate high or low side and wired appropriately. Use of polarized plugs allow for easy field inspection and repair.

Each unit comes standard with filter dryer (31). The condenser fan motor (32) can easily be accessed and maintained by removing the protective fan grille. The polarized plug connection allows the motor to be changed quickly and eliminates the need to snake wires through the unit. The outdoor coil uses the latest enhanced fin design (33) for the most effective method of heat transfer. The outdoor coil is slanted to protect it from Mother Nature.



Each unit is designed for both downflow or horizontal applications (34) for job configuration flexibility. The return air compartment can also contain an economizer (35).



Three models exist; two for downflow applications (a downflow economizer with factory installed smoke detector in the return section is available), and one for horizontal applications. Each unit is pre-wired for the economizer to allow quick plug-in installation. The downflow economizer is also available as a factory-installed option. Power Exhaust is easily field-installed. The economizer, which provides free cooling when outdoor conditions are suitable and also provides fresh air to meet local requirements, comes standard with single enthalpy controls. The controls can be upgraded to dual enthalpy easily in the field. The direct drive actuator combined with gear drive dampers has eliminated the need for linkage adjustment in the field. The economizer control has a minimum position setpoint, an outdoor-air setpoint, a mix-air setpoint, and a CO₂ setpoint. Barometric relief is standard on all economizers. The power exhaust is housed in the barometric relief opening and is easily slipped in with a plug-in assembly. The wire harness to the economizer also has accommodations for a smoke detector.



The damper minimum position, actual damper position, power exhaust on/off setpoint, mixed air temperature limit setpoint and Demand Controlled Ventilation (DCV) setpoint can be read and adjusted at the unit controller display or remotely through a network connection.

The Space CO₂ level, mixed air temperature, and Economizer Status (Free Cooling Available, Single or Dual Enthalpy) can be read at the unit controller display or remotely through a network connection. Economizer Faults will trigger a network Alarm and can be read at the unit controller display or remotely through a network connection.

The Ruud roofcurb (36) is made for toolless assembly at the jobsite by inserting a pin into a hinge in each corner of the adjacent curb sides (37), which makes the assembly process quick and easy.

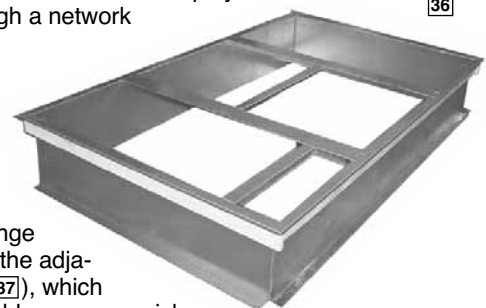



To select an RKNL-C Cooling and Heating unit to meet a job requirement, follow this procedure, with example, using data supplied in this specification sheet.

1. DETERMINE COOLING AND HEATING REQUIREMENTS AND SPECIFIC OPERATING CONDITIONS FROM PLANS AND SPECS.

Example:	
Voltage—	208/240V – 3 Phase – 60 Hz
Total Cooling Capacity—	205,000 BTUH [60.0 kW]
Sensible Cooling Capacity—	155,000 BTUH [45.4 kW]
Heating Capacity—	235,000 BTUH [68.8 kW]
*Condenser Entering Air—	95°F [35.0°C] DB
*Evaporator Mixed Air Entering—	65°F [18.3°C] WB 78°F [25.6°C] DB
*Indoor Air Flow (vertical)—	7200 CFM [3398 L/s]
*External Static Pressure—	0.70 in. WG [.17 kPa]

2. SELECT UNIT TO MEET COOLING REQUIREMENTS.

Since total cooling is within the range of a nominal 20 ton [70.3 kW] unit, enter cooling performance table at 95°F [35.0°C] DB condenser inlet air. Interpolate between 63°F [17.2°C] WB and 67°F [19.4°C] to determine total and sensible capacity and power input for 65°F [18.3°C] WB evaporator inlet air at 7725 CFM [3645 L/s] indoor air flow (table basis):

Total Cooling Capacity = 238,250 BTUH [69.76 kW]
Sensible Cooling Capacity = 192,550 BTUH [56.38 kW]
Power Input (Compressor and Cond. Fans) = 18,200 watts

Use formula in note ① to determine sensible capacity at 78°F [25.6°C] DB evaporator entering air:

$192,550 + (1.10 \times 7,200 \times (1 - 0.11) \times (78 - 80))$
Sensible Cooling Capacity = 178,452 BTUH [52.25 kW]

3. CORRECT CAPACITIES OF STEP 2 FOR ACTUAL AIR FLOW.

Select factors from airflow correction table at 7200 CFM [3398 L/s] and apply to data obtained in step 2 to obtain gross capacity:

Total Capacity = $238,250 \times 0.99 = 235,868$ BTUH [69.06 kW]
Sensible Capacity = $178,452 \times 0.96 = 171,314$ BTUH [50.16 kW]
Power Input = $18,200 \times 0.99 = 18,018$ Watts

These are Gross Capacities, not corrected for blower motor heat or power.

4. DETERMINE BLOWER SPEED AND WATTS TO MEET SYSTEM DESIGN.

Enter Indoor Blower performance table at 7200 CFM [3398 L/s]. Total ESP (external static pressure) per the spec of 0.70 in. WG [.17 kPa] includes the system duct and grilles. Add from the table "Component Air Resistance," 0.01 in. WG [.00 kPa] for wet coil, 0.08 in. WG [.02 kPa] for downflow air flow, for a total selection static pressure of 0.79 (0.8) in. WG [.20 kPa], and determine:

RPM = 739
WATTS = 2,862
DRIVE = L (standard 5 H.P. motor)

5. CALCULATE INDOOR BLOWER BTUH HEAT EFFECT FROM MOTOR WATTS, STEP 4.

$2,862 \times 3.412 = 9,765$ BTUH [2.86 kW]

6. CALCULATE NET COOLING CAPACITIES, EQUAL TO GROSS CAPACITY, STEP 3, MINUS INDOOR BLOWER MOTOR HEAT.

Net Total Capacity = $235,868 - 9,765 = 226,103$ BTUH [66.21 kW]
Net Sensible Capacity = $171,314 - 9,765 = 161,549$ BTUH [47.30 kW]

7. CALCULATE UNIT INPUT AND JOB EER.

Total Power Input = 18,018 (step 3) + 2,862 (step 4) = 20,880 Watts

$EER = \frac{\text{Net Total BTUH [kW] (step 6)}}{\text{Power Input, Watts (above)}} = \frac{226,103}{20,880} = 10.83$

8. SELECT UNIT HEATING CAPACITY.

From Physical Data Table read that gas heating output (input rating x efficiency) is:

Heating Capacity = 243,000 BTUH [71.2 kW]

9. CHOOSE MODEL RKNL-C240CL30E.

*NOTE: These operating conditions are typical of a commercial application in a 95°F/79°F [35°C/26°C] design area with indoor design of 76°F [24°C] DB and 50% RH and 10% ventilation air, with the unit roof mounted and centered on the zone it conditions by ducts.

[] Designates Metric Conversions

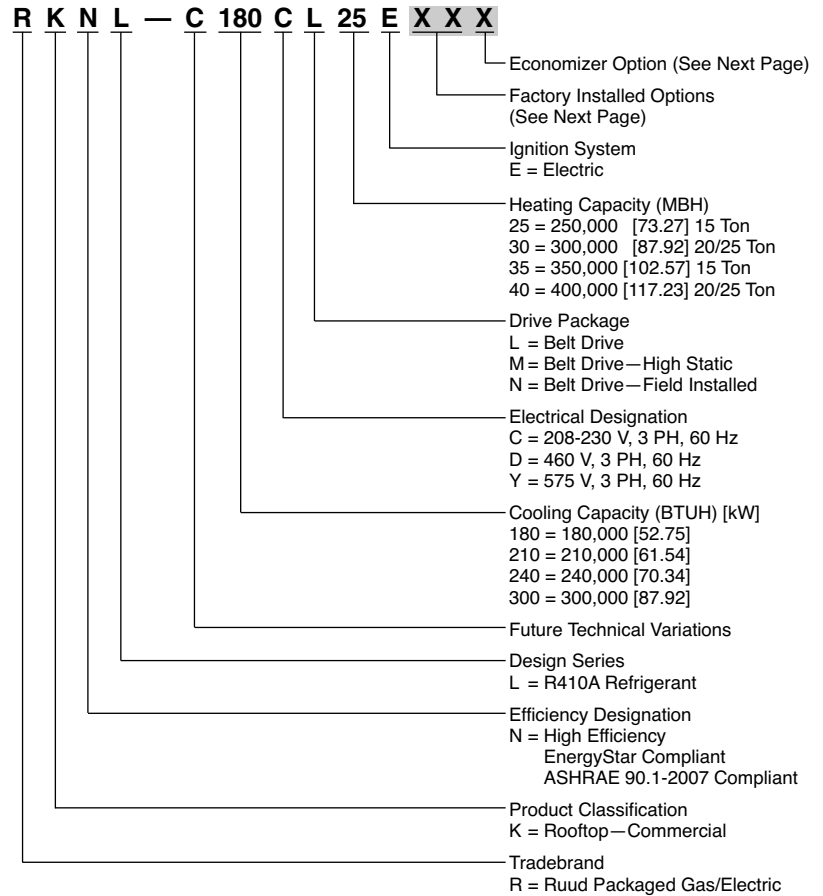

[] Designates Metric Conversions



FACTORY INSTALLED OPTION CODES FOR RKNL-C 180/210/240/300

Option Code	Stainless Steel Heat Exchanger	Non-Powered Convenience Outlet/Unfused Service Disconnect	Low Ambient/Comfort Alert	Variable Frequency Drive
AA				
AJ	x			
AH		x		
AR			x	
AU				x
JB	x	x		
CY	x	x	x	
DS	x	x	x	x

"x" indicates factory installed option.

ECONOMIZER SELECTION FOR RKNL-C 180/210/240/300

Option Code	No Economizer	DDC Single Enthalpy Economizer* With Barometric Relief	DDC Single Enthalpy Economizer* With Barometric Relief and Smoke Detector
A	x		
H		x	
J			x

"x" indicates factory installed option.

*Downflow economizer only.

Instructions for Factory Installed Option(s) Selection

Note: Three characters following the model number will be utilized to designate a factory-installed option or combination of options. If no factory option(s) is required, nothing follows the model number.

Step 1. After a basic rooftop model is selected, choose a two-character option code from the FACTORY INSTALLED OPTION SELECTION TABLE.

Proceed to Step 2.

Step 2. The last option code character is utilized for factory-installed economizers. Choose a character from the FACTORY INSTALLED ECONOMIZER SELECTION TABLE.

Example: RKNL-C240CL40E~~XX~~ (where ~~XX~~ is factory installed option)

Example: No Options

RKNL-C240CL40E

Example: No option with factory installed economizer

RKNL-C240CL40EAAH

Example: Options with low ambient and comfort alert, unwired convenience outlet, unfused service disconnect, and stainless steel heat exchanger with no factory installed economizer

RKNL-C240CL40ECYA

Example: Options same as above with factory installed economizer

RKNL-C240CL40ECYH



NOM. SIZES 15-25 TONS [52.8-87.9 kW] MODELS

Model RKNL-C Series	C180CL25E	C180CL35E	C180CM25E	C180CM35E
Cooling Performance¹				
Gross Cooling Capacity Btu [kW]	188,000 [55.08]	188,000 [55.08]	188,000 [55.08]	188,000 [55.08]
EER/SEER ²	11.1/NA	11.1/NA	11.1/NA	11.1/NA
Nominal CFM/AHRI Rated CFM [L/s]	6000/5900 [2831/2784]	6000/5900 [2831/2784]	6000/5900 [2831/2784]	6000/5900 [2831/2784]
AHRI Net Cooling Capacity Btu [kW]	182,000 [53.33]	182,000 [53.33]	182,000 [53.33]	182,000 [53.33]
Net Sensible Capacity Btu [kW]	135,700 [39.76]	135,700 [39.76]	135,700 [39.76]	135,700 [39.76]
Net Latent Capacity Btu [kW]	46,300 [13.57]	46,300 [13.57]	46,300 [13.57]	46,300 [13.57]
IEER ³	12.4	12.4	12.4	12.4
Net System Power kW	16.35	16.35	16.35	16.35
Heating Performance (Package Gas/Electric)⁴				
Heating Input Btu [kW] (1st Stage / 2nd Stage)	125,000/250,000 [36.62/73.25]	175,000/350,000 [51.27/102.55]	125,000/250,000 [36.62/73.25]	175,000/350,000 [51.27/102.55]
Heating Output Btu [kW] (1st Stage / 2nd Stage)	101,500/203,000 [29.74/59.48]	142,000/284,000 [41.61/83.21]	101,500/203,000 [29.74/59.48]	142,000/284,000 [41.61/83.21]
Temperature Rise Range °F [°C] (1st Stage / 2nd Stage)	0-0 [0/0] / 15-45 [8.3/25]	0-0 [0/0] / 30-60 [16.7/33.3]	0-0 [0/0] / 15-45 [8.3/25]	0-0 [0/0] / 30-60 [16.7/33.3]
Steady State Efficiency (%)	81	81	81	81
No. Burners	10	14	10	14
No. Stages	2	2	2	2
Gas Connection Pipe Size in. [mm]	0.75 [19]	0.75 [19]	0.75 [19]	0.75 [19]
Compressor				
No./Type	2/Scroll	2/Scroll	2/Scroll	2/Scroll
Outdoor Sound Rating (dB)⁵				
	91	91	91	91
Outdoor Coil—Fin Type				
Tube Type	Rifled	Rifled	Rifled	Rifled
Tube Size in. [mm] OD	0.375 [9.5]	0.375 [9.5]	0.375 [9.5]	0.375 [9.5]
Face Area sq. ft. [sq. m]	53.3 [4.95]	53.3 [4.95]	53.3 [4.95]	53.3 [4.95]
Rows / FPI [FPcm]	1 / 22 [9]	1 / 22 [9]	1 / 22 [9]	1 / 22 [9]
Indoor Coil—Fin Type				
Tube Type	Rifled	Rifled	Rifled	Rifled
Tube Size in. [mm]	0.375 [9.5]	0.375 [9.5]	0.375 [9.5]	0.375 [9.5]
Face Area sq. ft. [sq. m]	26.67 [2.48]	26.67 [2.48]	26.67 [2.48]	26.67 [2.48]
Rows / FPI [FPcm]	2 / 18 [7]	2 / 18 [7]	2 / 18 [7]	2 / 18 [7]
Refrigerant Control	TX Valves	TX Valves	TX Valves	TX Valves
Drain Connection No./Size in. [mm]	1/1 [25.4]	1/1 [25.4]	1/1 [25.4]	1/1 [25.4]
Outdoor Fan—Type				
No. Used/Diameter in. [mm]	4/24 [609.6]	4/24 [609.6]	4/24 [609.6]	4/24 [609.6]
Drive Type/No. Speeds	Direct/1	Direct/1	Direct/1	Direct/1
CFM [L/s]	16000 [7550]	16000 [7550]	16000 [7550]	16000 [7550]
No. Motors/HP	4 at 1/3 HP	4 at 1/3 HP	4 at 1/3 HP	4 at 1/3 HP
Motor RPM	1075	1075	1075	1075
Indoor Fan—Type				
No. Used/Diameter in. [mm]	2/18x9 [457x229]	2/18x9 [457x229]	2/18x9 [457x229]	2/18x9 [457x229]
Drive Type/No. Speeds	Belt/Variable	Belt/Variable	Belt/Variable	Belt/Variable
No. Motors	1	1	1	1
Motor HP	3	3	5	5
Motor RPM	1725	1725	1725	1725
Motor Frame Size	56	56	184	184
Filter—Type				
Furnished	Yes	Yes	Yes	Yes
(No.) Size Recommended in. [mm x mm x mm]	(8)2x25x20 [51x635x508]	(8)2x25x20 [51x635x508]	(8)2x25x20 [51x635x508]	(8)2x25x20 [51x635x508]
Refrigerant Charge Oz. (Sys. 1/Sys. 2) [g]				
	205/211 [5812/5982]	205/211 [5812/5982]	205/211 [5812/5982]	205/211 [5812/5982]
Weights				
Net Weight lbs. [kg]	1958 [888]	1971 [894]	1987 [901]	2000 [907]
Ship Weight lbs. [kg]	2058 [934]	2071 [939]	2087 [947]	2100 [953]

CONTINUED →

See Page 24 for Notes.

[] Designates Metric Conversions



NOM. SIZES 15-25 TONS [52.8-87.9 kW] MODELS

Model RKNL-C Series	C180DL25E	C180DL35E	C180DM25E	C180DM35E
Cooling Performance¹				CONTINUED →
Gross Cooling Capacity Btu [kW]	188,000 [55.08]	188,000 [55.08]	188,000 [55.08]	188,000 [55.08]
EER/SEER ²	11.1/NA	11.1/NA	11.1/NA	11.1/NA
Nominal CFM/AHRI Rated CFM [L/s]	6000/5900 [2831/2784]	6000/5900 [2831/2784]	6000/5900 [2831/2784]	6000/5900 [2831/2784]
AHRI Net Cooling Capacity Btu [kW]	182,000 [53.33]	182,000 [53.33]	182,000 [53.33]	182,000 [53.33]
Net Sensible Capacity Btu [kW]	135,700 [39.76]	135,700 [39.76]	135,700 [39.76]	135,700 [39.76]
Net Latent Capacity Btu [kW]	46,300 [13.57]	46,300 [13.57]	46,300 [13.57]	46,300 [13.57]
IEER ³	12.4	12.4	12.4	12.4
Net System Power kW	16.35	16.35	16.35	16.35
Heating Performance (Package Gas/Electric)⁴				
Heating Input Btu [kW] (1st Stage / 2nd Stage)	125,000/250,000 [36.62/73.25]	175,000/350,000 [51.27/102.55]	125,000/250,000 [36.62/73.25]	175,000/350,000 [51.27/102.55]
Heating Output Btu [kW] (1st Stage / 2nd Stage)	101,500/203,000 [29.74/59.48]	142,000/284,000 [41.61/83.21]	101,500/203,000 [29.74/59.48]	142,000/284,000 [41.61/83.21]
Temperature Rise Range °F [°C] (1st Stage / 2nd Stage)	0-0 [0/0] / 15-45 [8.3/25]	0-0 [0/0] / 30-60 [16.7/33.3]	0-0 [0/0] / 15-45 [8.3/25]	0-0 [0/0] / 30-60 [16.7/33.3]
Steady State Efficiency (%)	81	81	81	81
No. Burners	10	14	10	14
No. Stages	2	2	2	2
Gas Connection Pipe Size in. [mm]	0.75 [19]	0.75 [19]	0.75 [19]	0.75 [19]
Compressor				
No./Type	2/Scroll	2/Scroll	2/Scroll	2/Scroll
Outdoor Sound Rating (dB)⁵				
	91	91	91	91
Outdoor Coil—Fin Type				
Tube Type	Louvered	Louvered	Louvered	Louvered
Tube Size in. [mm] OD	0.375 [9.5]	0.375 [9.5]	0.375 [9.5]	0.375 [9.5]
Face Area sq. ft. [sq. m]	53.3 [4.95]	53.3 [4.95]	53.3 [4.95]	53.3 [4.95]
Rows / FPI [FPcm]	1 / 22 [9]	1 / 22 [9]	1 / 22 [9]	1 / 22 [9]
Indoor Coil—Fin Type				
Tube Type	Louvered	Louvered	Louvered	Louvered
Tube Size in. [mm]	0.375 [9.5]	0.375 [9.5]	0.375 [9.5]	0.375 [9.5]
Face Area sq. ft. [sq. m]	26.67 [2.48]	26.67 [2.48]	26.67 [2.48]	26.67 [2.48]
Rows / FPI [FPcm]	2 / 18 [7]	2 / 18 [7]	2 / 18 [7]	2 / 18 [7]
Refrigerant Control	TX Valves	TX Valves	TX Valves	TX Valves
Drain Connection No./Size in. [mm]	1/1 [25.4]	1/1 [25.4]	1/1 [25.4]	1/1 [25.4]
Outdoor Fan—Type				
No. Used/Diameter in. [mm]	4/24 [609.6]	4/24 [609.6]	4/24 [609.6]	4/24 [609.6]
Drive Type/No. Speeds	Direct/1	Direct/1	Direct/1	Direct/1
CFM [L/s]	16000 [7550]	16000 [7550]	16000 [7550]	16000 [7550]
No. Motors/HP	4 at 1/3 HP	4 at 1/3 HP	4 at 1/3 HP	4 at 1/3 HP
Motor RPM	1075	1075	1075	1075
Indoor Fan—Type				
No. Used/Diameter in. [mm]	FC Centrifugal 2/18x9 [457x229]	FC Centrifugal 2/18x9 [457x229]	FC Centrifugal 2/18x9 [457x229]	FC Centrifugal 2/18x9 [457x229]
Drive Type/No. Speeds	Belt/Variable	Belt/Variable	Belt/Variable	Belt/Variable
No. Motors	1	1	1	1
Motor HP	3	3	5	5
Motor RPM	1725	1725	1725	1725
Motor Frame Size	56	56	184	184
Filter—Type				
Furnished	Disposable Yes	Disposable Yes	Disposable Yes	Disposable Yes
(No.) Size Recommended in. [mm x mm x mm]	(8)2x25x20 [51x635x508]	(8)2x25x20 [51x635x508]	(8)2x25x20 [51x635x508]	(8)2x25x20 [51x635x508]
Refrigerant Charge Oz. (Sys. 1/Sys. 2) [g]				
	205/211 [5812/5982]	205/211 [5812/5982]	205/211 [5812/5982]	205/211 [5812/5982]
Weights				
Net Weight lbs. [kg]	1958 [888]	1971 [894]	1987 [901]	2000 [907]
Ship Weight lbs. [kg]	2058 [934]	2071 [939]	2087 [947]	2100 [953]

See Page 24 for Notes.

[] Designates Metric Conversions



NOM. SIZES 15-25 TONS [52.8-87.9 kW] MODELS

Model RKNL-C Series	C180YL35E	C180YM35E	C210CL25E	C210CL35E
Cooling Performance¹				
Gross Cooling Capacity Btu [kW]	188,000 [55.08]	188,000 [55.08]	212,000 [62.12]	212,000 [62.12]
EER/SEER ²	11.1/NA	11.1/NA	11.6/NA	11.6/NA
Nominal CFM/AHRI Rated CFM [L/s]	6000/5900 [2831/2784]	6000/5900 [2831/2784]	7000/7025 [3303/3315]	7000/7025 [3303/3315]
AHRI Net Cooling Capacity Btu [kW]	182,000 [53.33]	182,000 [53.33]	204,000 [59.77]	204,000 [59.77]
Net Sensible Capacity Btu [kW]	135,700 [39.76]	135,700 [39.76]	154,900 [45.39]	154,900 [45.39]
Net Latent Capacity Btu [kW]	46,300 [13.57]	46,300 [13.57]	49,100 [14.39]	49,100 [14.39]
IEER ³	12.4	12.4	12.6	12.6
Net System Power kW	16.35	16.35	17.57	17.57
Heating Performance (Package Gas/Electric)⁴				
Heating Input Btu [kW] (1st Stage / 2nd Stage)	175,000/350,000 [51.27/102.55]	175,000/350,000 [51.27/102.55]	125,000/250,000 [36.62/73.25]	175,000/350,000 [51.27/102.55]
Heating Output Btu [kW] (1st Stage / 2nd Stage)	142,000/284,000 [41.61/83.21]	142,000/284,000 [41.61/83.21]	101,500/203,000 [29.74/59.48]	142,000/284,000 [41.61/83.21]
Temperature Rise Range °F [°C] (1st Stage / 2nd Stage)	0-0 [0/0] / 30-60 [16.7/33.3]	0-0 [0/0] / 30-60 [16.7/33.3]	0-0 [0/0] / 15-45 [8.3/25]	0-0 [0/0] / 25-55 [13.9/30.6]
Steady State Efficiency (%)	81	81	81	81
No. Burners	14	14	10	14
No. Stages	2	2	2	2
Gas Connection Pipe Size in. [mm]	0.75 [19]	0.75 [19]	0.75 [19]	0.75 [19]
Compressor				
No./Type	2/Scroll	2/Scroll	2/Scroll	2/Scroll
Outdoor Sound Rating (dB)⁵				
	91	91	91	91
Outdoor Coil—Fin Type				
Tube Type	Rifled	Rifled	Rifled	Rifled
Tube Size in. [mm] OD	0.375 [9.5]	0.375 [9.5]	0.375 [9.5]	0.375 [9.5]
Face Area sq. ft. [sq. m]	53.3 [4.95]	53.3 [4.95]	53.3 [4.95]	53.3 [4.95]
Rows / FPI [FPcm]	1 / 22 [9]	1 / 22 [9]	2 / 18 [7]	2 / 18 [7]
Indoor Coil—Fin Type				
Tube Type	Rifled	Rifled	Rifled	Rifled
Tube Size in. [mm]	0.375 [9.5]	0.375 [9.5]	0.375 [9.5]	0.375 [9.5]
Face Area sq. ft. [sq. m]	26.67 [2.48]	26.67 [2.48]	26.67 [2.48]	26.67 [2.48]
Rows / FPI [FPcm]	2 / 18 [7]	2 / 18 [7]	2 / 18 [7]	2 / 18 [7]
Refrigerant Control	TX Valves	TX Valves	TX Valves	TX Valves
Drain Connection No./Size in. [mm]	1/1 [25.4]	1/1 [25.4]	1/1 [25.4]	1/1 [25.4]
Outdoor Fan—Type				
No. Used/Diameter in. [mm]	4/24 [609.6]	4/24 [609.6]	4/24 [609.6]	4/24 [609.6]
Drive Type/No. Speeds	Direct/1	Direct/1	Direct/1	Direct/1
CFM [L/s]	16000 [7550]	16000 [7550]	14800 [6984]	14800 [6984]
No. Motors/HP	4 at 1/3 HP	4 at 1/3 HP	4 at 1/3 HP	4 at 1/3 HP
Motor RPM	1075	1075	1075	1075
Indoor Fan—Type				
No. Used/Diameter in. [mm]	2/18x9 [457x229]	2/18x9 [457x229]	2/18x9 [457x229]	2/18x9 [457x229]
Drive Type/No. Speeds	Belt/Variable	Belt/Variable	Belt/Variable	Belt/Variable
No. Motors	1	1	1	1
Motor HP	3	5	3	3
Motor RPM	1725	1725	1725	1725
Motor Frame Size	56	184	56	56
Filter—Type				
Furnished	Yes	Yes	Yes	Yes
(No.) Size Recommended in. [mm x mm x mm]	(8)2x25x20 [51x635x508]	(8)2x25x20 [51x635x508]	(8)2x25x20 [51x635x508]	(8)2x25x20 [51x635x508]
Refrigerant Charge Oz. (Sys. 1/Sys. 2) [g]				
	205/211 [5812/5982]	205/211 [5812/5982]	294/302 [8335/8562]	294/302 [8335/8562]
Weights				
Net Weight lbs. [kg]	1986 [901]	2015 [914]	2145 [973]	2158 [979]
Ship Weight lbs. [kg]	2086 [946]	2115 [959]	2272 [1031]	2285 [1036]

CONTINUED →

See Page 24 for Notes.

[] Designates Metric Conversions



NOM. SIZES 15-25 TONS [52.8-87.9 kW] MODELS

Model RKNL-C Series	C210CM25E	C210CM35E	C210DL25E	C210DL35E
Cooling Performance¹				
Gross Cooling Capacity Btu [kW]	212,000 [62.12]	212,000 [62.12]	212,000 [62.12]	212,000 [62.12]
EER/SEER ²	11.6/NA	11.6/NA	11.6/NA	11.6/NA
Nominal CFM/AHRI Rated CFM [L/s]	7000/7025 [3303/3315]	7000/7025 [3303/3315]	7000/7025 [3303/3315]	7000/7025 [3303/3315]
AHRI Net Cooling Capacity Btu [kW]	204,000 [59.77]	204,000 [59.77]	204,000 [59.77]	204,000 [59.77]
Net Sensible Capacity Btu [kW]	154,900 [45.39]	154,900 [45.39]	154,900 [45.39]	154,900 [45.39]
Net Latent Capacity Btu [kW]	49,100 [14.39]	49,100 [14.39]	49,100 [14.39]	49,100 [14.39]
IEER ³	12.6	12.6	12.6	12.6
Net System Power kW	17.57	17.57	17.57	17.57
Heating Performance (Package Gas/Electric)⁴				
Heating Input Btu [kW] (1st Stage / 2nd Stage)	125,000/250,000 [36.62/73.25]	175,000/350,000 [51.27/102.55]	125,000/250,000 [36.62/73.25]	175,000/350,000 [51.27/102.55]
Heating Output Btu [kW] (1st Stage / 2nd Stage)	101,500/203,000 [29.74/59.48]	142,000/284,000 [41.61/83.21]	101,500/203,000 [29.74/59.48]	142,000/284,000 [41.61/83.21]
Temperature Rise Range °F [°C] (1st Stage / 2nd Stage)	0-0 [0/0] / 15-45 [8.3/25]	0-0 [0/0] / 25-55 [13.9/30.6]	0-0 [0/0] / 15-45 [8.3/25]	0-0 [0/0] / 25-55 [13.9/30.6]
Steady State Efficiency (%)	81	81	81	81
No. Burners	10	14	10	14
No. Stages	2	2	2	2
Gas Connection Pipe Size in. [mm]	0.75 [19]	0.75 [19]	0.75 [19]	0.75 [19]
Compressor				
No./Type	2/Scroll	2/Scroll	2/Scroll	2/Scroll
Outdoor Sound Rating (dB)⁵				
	91	91	91	91
Outdoor Coil—Fin Type				
Tube Type	Rifled	Rifled	Rifled	Rifled
Tube Size in. [mm] OD	0.375 [9.5]	0.375 [9.5]	0.375 [9.5]	0.375 [9.5]
Face Area sq. ft. [sq. m]	53.3 [4.95]	53.3 [4.95]	53.3 [4.95]	53.3 [4.95]
Rows / FPI [FPcm]	2 / 18 [7]	2 / 18 [7]	2 / 18 [7]	2 / 18 [7]
Indoor Coil—Fin Type				
Tube Type	Rifled	Rifled	Rifled	Rifled
Tube Size in. [mm]	0.375 [9.5]	0.375 [9.5]	0.375 [9.5]	0.375 [9.5]
Face Area sq. ft. [sq. m]	26.67 [2.48]	26.67 [2.48]	26.67 [2.48]	26.67 [2.48]
Rows / FPI [FPcm]	2 / 18 [7]	2 / 18 [7]	2 / 18 [7]	2 / 18 [7]
Refrigerant Control	TX Valves	TX Valves	TX Valves	TX Valves
Drain Connection No./Size in. [mm]	1/1 [25.4]	1/1 [25.4]	1/1 [25.4]	1/1 [25.4]
Outdoor Fan—Type				
No. Used/Diameter in. [mm]	4/24 [609.6]	4/24 [609.6]	4/24 [609.6]	4/24 [609.6]
Drive Type/No. Speeds	Direct/1	Direct/1	Direct/1	Direct/1
CFM [L/s]	14800 [6984]	14800 [6984]	14800 [6984]	14800 [6984]
No. Motors/HP	4 at 1/3 HP	4 at 1/3 HP	4 at 1/3 HP	4 at 1/3 HP
Motor RPM	1075	1075	1075	1075
Indoor Fan—Type				
No. Used/Diameter in. [mm]	2/18x9 [457x229]	2/18x9 [457x229]	2/18x9 [457x229]	2/18x9 [457x229]
Drive Type/No. Speeds	Belt/Variable	Belt/Variable	Belt/Variable	Belt/Variable
No. Motors	1	1	1	1
Motor HP	5	5	3	3
Motor RPM	1725	1725	1725	1725
Motor Frame Size	184	184	56	56
Filter—Type				
Furnished	Disposable	Disposable	Disposable	Disposable
(No.) Size Recommended in. [mm x mm x mm]	(8)2x25x20 [51x635x508]	(8)2x25x20 [51x635x508]	(8)2x25x20 [51x635x508]	(8)2x25x20 [51x635x508]
Refrigerant Charge Oz. (Sys. 1/Sys. 2) [g]				
	294/302 [8335/8562]	294/302 [8335/8562]	294/302 [8335/8562]	294/302 [8335/8562]
Weights				
Net Weight lbs. [kg]	2174 [986]	2187 [992]	2145 [973]	2158 [979]
Ship Weight lbs. [kg]	2301 [1044]	2314 [1050]	2272 [1031]	2285 [1036]

CONTINUED →

See Page 24 for Notes.

[] Designates Metric Conversions



NOM. SIZES 15-25 TONS [52.8-87.9 kW] MODELS

Model RKNL-C Series	C210DM25E	C210DM35E	C210YL35E	C210YM35E
Cooling Performance¹				
Gross Cooling Capacity Btu [kW]	212,000 [62.12]	212,000 [62.12]	212,000 [62.12]	212,000 [62.12]
EER/SEER ²	11.6/NA	11.6/NA	11.6/NA	11.6/NA
Nominal CFM/AHRI Rated CFM [L/s]	7000/7025 [3303/3315]	7000/7025 [3303/3315]	7000/7025 [3303/3315]	7000/7025 [3303/3315]
AHRI Net Cooling Capacity Btu [kW]	204,000 [59.77]	204,000 [59.77]	204,000 [59.77]	204,000 [59.77]
Net Sensible Capacity Btu [kW]	154,900 [45.39]	154,900 [45.39]	154,900 [45.39]	154,900 [45.39]
Net Latent Capacity Btu [kW]	49,100 [14.39]	49,100 [14.39]	49,100 [14.39]	49,100 [14.39]
IEER ³	12.6	12.6	12.6	12.6
Net System Power kW	17.57	17.57	17.57	17.57
Heating Performance (Package Gas/Electric)⁴				
Heating Input Btu [kW] (1st Stage / 2nd Stage)	125,000/250,000 [36.62/73.25]	175,000/350,000 [51.27/102.55]	175,000/350,000 [51.27/102.55]	175,000/350,000 [51.27/102.55]
Heating Output Btu [kW] (1st Stage / 2nd Stage)	101,500/203,000 [29.74/59.48]	142,000/284,000 [41.61/83.21]	142,000/284,000 [41.61/83.21]	142,000/284,000 [41.61/83.21]
Temperature Rise Range °F [°C] (1st Stage / 2nd Stage)	0-0 [0/0] / 15-45 [8.3/25]	0-0 [0/0] / 25-55 [13.9/30.6]	0-0 [0/0] / 25-55 [13.9/30.6]	0-0 [0/0] / 25-55 [13.9/30.6]
Steady State Efficiency (%)	81	81	81	81
No. Burners	10	14	14	14
No. Stages	2	2	2	2
Gas Connection Pipe Size in. [mm]	0.75 [19]	0.75 [19]	0.75 [19]	0.75 [19]
Compressor				
No./Type	2/Scroll	2/Scroll	2/Scroll	2/Scroll
Outdoor Sound Rating (dB)⁵				
	91	91	91	91
Outdoor Coil—Fin Type				
Tube Type	Rifled	Rifled	Rifled	Rifled
Tube Size in. [mm] OD	0.375 [9.5]	0.375 [9.5]	0.375 [9.5]	0.375 [9.5]
Face Area sq. ft. [sq. m]	53.3 [4.95]	53.3 [4.95]	53.3 [4.95]	53.3 [4.95]
Rows / FPI [FPcm]	2 / 18 [7]	2 / 18 [7]	2 / 18 [7]	2 / 18 [7]
Indoor Coil—Fin Type				
Tube Type	Rifled	Rifled	Rifled	Rifled
Tube Size in. [mm]	0.375 [9.5]	0.375 [9.5]	0.375 [9.5]	0.375 [9.5]
Face Area sq. ft. [sq. m]	26.67 [2.48]	26.67 [2.48]	26.67 [2.48]	26.67 [2.48]
Rows / FPI [FPcm]	2 / 18 [7]	2 / 18 [7]	2 / 18 [7]	2 / 18 [7]
Refrigerant Control	TX Valves	TX Valves	TX Valves	TX Valves
Drain Connection No./Size in. [mm]	1/1 [25.4]	1/1 [25.4]	1/1 [25.4]	1/1 [25.4]
Outdoor Fan—Type				
No. Used/Diameter in. [mm]	4/24 [609.6]	4/24 [609.6]	4/24 [609.6]	4/24 [609.6]
Drive Type/No. Speeds	Direct/1	Direct/1	Direct/1	Direct/1
CFM [L/s]	14800 [6984]	14800 [6984]	14800 [6984]	14800 [6984]
No. Motors/HP	4 at 1/3 HP	4 at 1/3 HP	4 at 1/3 HP	4 at 1/3 HP
Motor RPM	1075	1075	1075	1075
Indoor Fan—Type				
No. Used/Diameter in. [mm]	2/18x9 [457x229]	2/18x9 [457x229]	2/18x9 [457x229]	2/18x9 [457x229]
Drive Type/No. Speeds	Belt/Variable	Belt/Variable	Belt/Variable	Belt/Variable
No. Motors	1	1	1	1
Motor HP	5	5	3	5
Motor RPM	1725	1725	1725	1725
Motor Frame Size	184	184	56	184
Filter—Type				
Furnished	Yes	Yes	Yes	Yes
(No.) Size Recommended in. [mm x mm x mm]	(8)2x25x20 [51x635x508]	(8)2x25x20 [51x635x508]	(8)2x25x20 [51x635x508]	(8)2x25x20 [51x635x508]
Refrigerant Charge Oz. (Sys. 1/Sys. 2) [g]				
	294/302 [8335/8562]	294/302 [8335/8562]	294/302 [8335/8562]	294/302 [8335/8562]
Weights				
Net Weight lbs. [kg]	2174 [986]	2187 [992]	2173 [986]	2202 [999]
Ship Weight lbs. [kg]	2301 [1044]	2314 [1050]	2300 [1043]	2329 [1056]

See Page 24 for Notes.

[] Designates Metric Conversions



NOM. SIZES 15-25 TONS [52.8-87.9 kW] MODELS

Model RKNL-C Series	C240CL30E	C240CL40E	C240CM30E	C240CM40E
Cooling Performance¹				CONTINUED →
Gross Cooling Capacity Btu [kW]	244,000 [71.49]	244,000 [71.49]	244,000 [71.49]	244,000 [71.49]
EER/SEER ²	11.1/NA	11.1/NA	11.1/NA	11.1/NA
Nominal CFM/AHRI Rated CFM [L/s]	8000/7725 [3775/3645]	8000/7725 [3775/3645]	8000/7725 [3775/3645]	8000/7725 [3775/3645]
AHRI Net Cooling Capacity Btu [kW]	234,000 [68.56]	234,000 [68.56]	234,000 [68.56]	234,000 [68.56]
Net Sensible Capacity Btu [kW]	171,600 [50.28]	171,600 [50.28]	171,600 [50.28]	171,600 [50.28]
Net Latent Capacity Btu [kW]	62,400 [18.28]	62,400 [18.28]	62,400 [18.28]	62,400 [18.28]
IEER ³	11.4	11.4	11.4	11.4
Net System Power kW	21.04	21.04	21.04	21.04
Heating Performance (Package Gas/Electric)⁴				
Heating Input Btu [kW] (1st Stage / 2nd Stage)	150,000/300,000 [43.95/87.9]	200,000/400,000 [58.6/117.2]	150,000/300,000 [43.95/87.9]	200,000/400,000 [58.6/117.2]
Heating Output Btu [kW] (1st Stage / 2nd Stage)	121,500/243,000 [35.6/71.2]	162,000/324,000 [47.47/94.93]	121,500/243,000 [35.6/71.2]	162,000/324,000 [47.47/94.93]
Temperature Rise Range °F [°C] (1st Stage / 2nd Stage)	0-0 [0/0] / 15-45 [8.3/25]	0-0 [0/0] / 25-55 [13.9/30.6]	0-0 [0/0] / 15-45 [8.3/25]	0-0 [0/0] / 25-55 [13.9/30.6]
Steady State Efficiency (%)	81	81	81	81
No. Burners	12	14	12	14
No. Stages	2	2	2	2
Gas Connection Pipe Size in. [mm]	0.75 [19]	0.75 [19]	0.75 [19]	0.75 [19]
Compressor				
No./Type	2/Scroll	2/Scroll	2/Scroll	2/Scroll
Outdoor Sound Rating (dB)⁵				
	91	91	91	91
Outdoor Coil—Fin Type				
Tube Type	Rifled	Rifled	Rifled	Rifled
Tube Size in. [mm] OD	0.375 [9.5]	0.375 [9.5]	0.375 [9.5]	0.375 [9.5]
Face Area sq. ft. [sq. m]	53.3 [4.95]	53.3 [4.95]	53.3 [4.95]	53.3 [4.95]
Rows / FPI [FPcm]	2 / 22 [9]	2 / 22 [9]	2 / 22 [9]	2 / 22 [9]
Indoor Coil—Fin Type				
Tube Type	Rifled	Rifled	Rifled	Rifled
Tube Size in. [mm]	0.375 [9.5]	0.375 [9.5]	0.375 [9.5]	0.375 [9.5]
Face Area sq. ft. [sq. m]	26.67 [2.48]	26.67 [2.48]	26.67 [2.48]	26.67 [2.48]
Rows / FPI [FPcm]	3 / 13 [5]	3 / 13 [5]	3 / 13 [5]	3 / 13 [5]
Refrigerant Control	TX Valves	TX Valves	TX Valves	TX Valves
Drain Connection No./Size in. [mm]	1/1 [25.4]	1/1 [25.4]	1/1 [25.4]	1/1 [25.4]
Outdoor Fan—Type				
No. Used/Diameter in. [mm]	6/24 [609.6]	6/24 [609.6]	6/24 [609.6]	6/24 [609.6]
Drive Type/No. Speeds	Direct/1	Direct/1	Direct/1	Direct/1
CFM [L/s]	19800 [9344]	19800 [9344]	19800 [9344]	19800 [9344]
No. Motors/HP	6 at 1/3 HP	6 at 1/3 HP	6 at 1/3 HP	6 at 1/3 HP
Motor RPM	1075	1075	1075	1075
Indoor Fan—Type				
No. Used/Diameter in. [mm]	2/18x9 [457x229]	2/18x9 [457x229]	2/18x9 [457x229]	2/18x9 [457x229]
Drive Type/No. Speeds	Belt/Variable	Belt/Variable	Belt/Variable	Belt/Variable
No. Motors	1	1	1	1
Motor HP	5	5	7 1/2	7 1/2
Motor RPM	1725	1725	1725	1725
Motor Frame Size	184	184	213	213
Filter—Type				
Furnished	Disposable	Disposable	Disposable	Disposable
(No.) Size Recommended in. [mm x mm x mm]	(8)2x25x20 [51x635x508]	(8)2x25x20 [51x635x508]	(8)2x25x20 [51x635x508]	(8)2x25x20 [51x635x508]
Refrigerant Charge Oz. (Sys. 1/Sys. 2) [g]				
	402/331 [11397/9384]	402/331 [11397/9384]	402/331 [11397/9384]	402/331 [11397/9384]
Weights				
Net Weight lbs. [kg]	2289 [1038]	2303 [1045]	2327 [1056]	2341 [1062]
Ship Weight lbs. [kg]	2389 [1084]	2403 [1090]	2427 [1101]	2441 [1107]

See Page 24 for Notes.

[] Designates Metric Conversions



NOM. SIZES 15-25 TONS [52.8-87.9 kW] MODELS

Model RKNL-C Series	C240CN30E	C240CN40E	C240DL30E	C240DL40E
Cooling Performance¹				
Gross Cooling Capacity Btu [kW]	244,000 [71.49]	244,000 [71.49]	244,000 [71.49]	244,000 [71.49]
EER/SEER ²	11.1/NA	11.1/NA	11.1/NA	11.1/NA
Nominal CFM/AHRI Rated CFM [L/s]	8000/7725 [3775/3645]	8000/7725 [3775/3645]	8000/7725 [3775/3645]	8000/7725 [3775/3645]
AHRI Net Cooling Capacity Btu [kW]	234,000 [68.56]	234,000 [68.56]	234,000 [68.56]	234,000 [68.56]
Net Sensible Capacity Btu [kW]	171,600 [50.28]	171,600 [50.28]	171,600 [50.28]	171,600 [50.28]
Net Latent Capacity Btu [kW]	62,400 [18.28]	62,400 [18.28]	62,400 [18.28]	62,400 [18.28]
IEER ³	11.4	11.4	11.4	11.4
Net System Power kW	21.04	21.04	21.04	21.04
Heating Performance (Package Gas/Electric)⁴				
Heating Input Btu [kW] (1st Stage / 2nd Stage)	150,000/300,000 [43.95/87.9]	200,000/400,000 [58.6/117.2]	150,000/300,000 [43.95/87.9]	200,000/400,000 [58.6/117.2]
Heating Output Btu [kW] (1st Stage / 2nd Stage)	121,500/243,000 [35.6/71.2]	162,000/324,000 [47.47/94.93]	121,500/243,000 [35.6/71.2]	162,000/324,000 [47.47/94.93]
Temperature Rise Range °F [°C] (1st Stage / 2nd Stage)	0-0 [0/0] / 15-45 [8.3/25]	0-0 [0/0] / 25-55 [13.9/30.6]	0-0 [0/0] / 15-45 [8.3/25]	0-0 [0/0] / 25-55 [13.9/30.6]
Steady State Efficiency (%)	81	81	81	81
No. Burners	12	14	12	14
No. Stages	2	2	2	2
Gas Connection Pipe Size in. [mm]	0.75 [19]	0.75 [19]	0.75 [19]	0.75 [19]
Compressor				
No./Type	2/Scroll	2/Scroll	2/Scroll	2/Scroll
Outdoor Sound Rating (dB)⁵				
	91	91	91	91
Outdoor Coil—Fin Type				
Tube Type	Rifled	Rifled	Rifled	Rifled
Tube Size in. [mm] OD	0.375 [9.5]	0.375 [9.5]	0.375 [9.5]	0.375 [9.5]
Face Area sq. ft. [sq. m]	53.3 [4.95]	53.3 [4.95]	53.3 [4.95]	53.3 [4.95]
Rows / FPI [FPcm]	2 / 22 [9]	2 / 22 [9]	2 / 22 [9]	2 / 22 [9]
Indoor Coil—Fin Type				
Tube Type	Rifled	Rifled	Rifled	Rifled
Tube Size in. [mm]	0.375 [9.5]	0.375 [9.5]	0.375 [9.5]	0.375 [9.5]
Face Area sq. ft. [sq. m]	26.67 [2.48]	26.67 [2.48]	26.67 [2.48]	26.67 [2.48]
Rows / FPI [FPcm]	3 / 13 [5]	3 / 13 [5]	3 / 13 [5]	3 / 13 [5]
Refrigerant Control	TX Valves	TX Valves	TX Valves	TX Valves
Drain Connection No./Size in. [mm]	1/1 [25.4]	1/1 [25.4]	1/1 [25.4]	1/1 [25.4]
Outdoor Fan—Type				
No. Used/Diameter in. [mm]	6/24 [609.6]	6/24 [609.6]	6/24 [609.6]	6/24 [609.6]
Drive Type/No. Speeds	Direct/1	Direct/1	Direct/1	Direct/1
CFM [L/s]	19800 [9344]	19800 [9344]	19800 [9344]	19800 [9344]
No. Motors/HP	6 at 1/3 HP	6 at 1/3 HP	6 at 1/3 HP	6 at 1/3 HP
Motor RPM	1075	1075	1075	1075
Indoor Fan—Type				
No. Used/Diameter in. [mm]	2/18x9 [457x229]	2/18x9 [457x229]	2/18x9 [457x229]	2/18x9 [457x229]
Drive Type/No. Speeds	Belt/Variable	Belt/Variable	Belt/Variable	Belt/Variable
No. Motors	1	1	1	1
Motor HP	7 1/2	7 1/2	5	5
Motor RPM	1725	1725	1725	1725
Motor Frame Size	213	213	184	184
Filter—Type				
Furnished	Disposable	Disposable	Disposable	Disposable
(No.) Size Recommended in. [mm x mm x mm]	(8)2x25x20 [51x635x508]	(8)2x25x20 [51x635x508]	(8)2x25x20 [51x635x508]	(8)2x25x20 [51x635x508]
Refrigerant Charge Oz. (Sys. 1/Sys. 2) [g]				
	402/331 [11397/9384]	402/331 [11397/9384]	402/331 [11397/9384]	402/331 [11397/9384]
Weights				
Net Weight lbs. [kg]	2325 [1055]	2340 [1061]	2289 [1038]	2303 [1045]
Ship Weight lbs. [kg]	2425 [1100]	2440 [1107]	2389 [1084]	2403 [1090]

CONTINUED →

See Page 24 for Notes.

[] Designates Metric Conversions



NOM. SIZES 15-25 TONS [52.8-87.9 kW] MODELS

Model RKNL-C Series	C240DM30E	C240DM40E	C240DN30E	C240DN40E
Cooling Performance¹				CONTINUED →
Gross Cooling Capacity Btu [kW]	244,000 [71.49]	244,000 [71.49]	244,000 [71.49]	244,000 [71.49]
EER/SEER ²	11.1/NA	11.1/NA	11.1/NA	11.1/NA
Nominal CFM/AHRI Rated CFM [L/s]	8000/7725 [3775/3645]	8000/7725 [3775/3645]	8000/7725 [3775/3645]	8000/7725 [3775/3645]
AHRI Net Cooling Capacity Btu [kW]	234,000 [68.56]	234,000 [68.56]	234,000 [68.56]	234,000 [68.56]
Net Sensible Capacity Btu [kW]	171,600 [50.28]	171,600 [50.28]	171,600 [50.28]	171,600 [50.28]
Net Latent Capacity Btu [kW]	62,400 [18.28]	62,400 [18.28]	62,400 [18.28]	62,400 [18.28]
IEER ³	11.4	11.4	11.4	11.4
Net System Power kW	21.04	21.04	21.04	21.04
Heating Performance (Package Gas/Electric)⁴				
Heating Input Btu [kW] (1st Stage / 2nd Stage)	150,000/300,000 [43.95/87.9]	200,000/400,000 [58.6/117.2]	150,000/300,000 [43.95/87.9]	200,000/400,000 [58.6/117.2]
Heating Output Btu [kW] (1st Stage / 2nd Stage)	121,500/243,000 [35.6/71.2]	162,000/324,000 [47.47/94.93]	121,500/243,000 [35.6/71.2]	162,000/324,000 [47.47/94.93]
Temperature Rise Range °F [°C] (1st Stage / 2nd Stage)	0-0 [0/0] / 15-45 [8.3/25]	0-0 [0/0] / 25-55 [13.9/30.6]	0-0 [0/0] / 15-45 [8.3/25]	0-0 [0/0] / 25-55 [13.9/30.6]
Steady State Efficiency (%)	81	81	81	81
No. Burners	12	14	12	14
No. Stages	2	2	2	2
Gas Connection Pipe Size in. [mm]	0.75 [19]	0.75 [19]	0.75 [19]	0.75 [19]
Compressor				
No./Type	2/Scroll	2/Scroll	2/Scroll	2/Scroll
Outdoor Sound Rating (dB)⁵				
	91	91	91	91
Outdoor Coil—Fin Type				
Tube Type	Rifled	Rifled	Rifled	Rifled
Tube Size in. [mm] OD	0.375 [9.5]	0.375 [9.5]	0.375 [9.5]	0.375 [9.5]
Face Area sq. ft. [sq. m]	53.3 [4.95]	53.3 [4.95]	53.3 [4.95]	53.3 [4.95]
Rows / FPI [FPcm]	2 / 22 [9]	2 / 22 [9]	2 / 22 [9]	2 / 22 [9]
Indoor Coil—Fin Type				
Tube Type	Rifled	Rifled	Rifled	Rifled
Tube Size in. [mm]	0.375 [9.5]	0.375 [9.5]	0.375 [9.5]	0.375 [9.5]
Face Area sq. ft. [sq. m]	26.67 [2.48]	26.67 [2.48]	26.67 [2.48]	26.67 [2.48]
Rows / FPI [FPcm]	3 / 13 [5]	3 / 13 [5]	3 / 13 [5]	3 / 13 [5]
Refrigerant Control	TX Valves	TX Valves	TX Valves	TX Valves
Drain Connection No./Size in. [mm]	1/1 [25.4]	1/1 [25.4]	1/1 [25.4]	1/1 [25.4]
Outdoor Fan—Type				
No. Used/Diameter in. [mm]	6/24 [609.6]	6/24 [609.6]	6/24 [609.6]	6/24 [609.6]
Drive Type/No. Speeds	Direct/1	Direct/1	Direct/1	Direct/1
CFM [L/s]	19800 [9344]	19800 [9344]	19800 [9344]	19800 [9344]
No. Motors/HP	6 at 1/3 HP	6 at 1/3 HP	6 at 1/3 HP	6 at 1/3 HP
Motor RPM	1075	1075	1075	1075
Indoor Fan—Type				
No. Used/Diameter in. [mm]	2/18x9 [457x229]	2/18x9 [457x229]	2/18x9 [457x229]	2/18x9 [457x229]
Drive Type/No. Speeds	Belt/Variable	Belt/Variable	Belt/Variable	Belt/Variable
No. Motors	1	1	1	1
Motor HP	7 1/2	7 1/2	7 1/2	7 1/2
Motor RPM	1725	1725	1725	1725
Motor Frame Size	184	213	184	213
Filter—Type				
Furnished	Disposable	Disposable	Disposable	Disposable
(No.) Size Recommended in. [mm x mm x mm]	(8)2x25x20 [51x635x508]	(8)2x25x20 [51x635x508]	(8)2x25x20 [51x635x508]	(8)2x25x20 [51x635x508]
Refrigerant Charge Oz. (Sys. 1/Sys. 2) [g]				
	402/331 [11397/9384]	402/331 [11397/9384]	402/331 [11397/9384]	402/331 [11397/9384]
Weights				
Net Weight lbs. [kg]	2327 [1056]	2341 [1062]	2325 [1055]	2340 [1061]
Ship Weight lbs. [kg]	2427 [1101]	2441 [1107]	2425 [1100]	2440 [1107]

See Page 24 for Notes.

[] Designates Metric Conversions



NOM. SIZES 15-25 TONS [52.8-87.9 kW] MODELS

Model RKNL-C Series	C240YL40E	C240YM40E	C240YN40E	C300CL30E
Cooling Performance¹				CONTINUED →
Gross Cooling Capacity Btu [kW]	244,000 [71.49]	244,000 [71.49]	244,000 [71.49]	312,000 [91.42]
EER/SEER ²	11.1/NA	11.1/NA	11.1/NA	10/NA
Nominal CFM/AHRI Rated CFM [L/s]	8000/7725 [3775/3645]	8000/7725 [3775/3645]	8000/7725 [3775/3645]	10000/9475 [4719/4471]
AHRI Net Cooling Capacity Btu [kW]	234,000 [68.56]	234,000 [68.56]	234,000 [68.56]	294,000 [86.14]
Net Sensible Capacity Btu [kW]	171,600 [50.28]	171,600 [50.28]	171,600 [50.28]	214,100 [62.73]
Net Latent Capacity Btu [kW]	62,400 [18.28]	62,400 [18.28]	62,400 [18.28]	79,900 [23.41]
IEER ³	11.4	11.4	11.4	10.1
Net System Power kW	21.04	21.04	21.04	29.39
Heating Performance (Package Gas/Electric)⁴				
Heating Input Btu [kW] (1st Stage / 2nd Stage)	200,000/400,000 [58.6/117.2]	200,000/400,000 [58.6/117.2]	200,000/400,000 [58.6/117.2]	150,000/300,000 [43.95/87.9]
Heating Output Btu [kW] (1st Stage / 2nd Stage)	162,000/324,000 [47.47/94.93]	162,000/324,000 [47.47/94.93]	162,000/324,000 [47.47/94.93]	121,500/243,000 [35.6/71.2]
Temperature Rise Range °F [°C] (1st Stage / 2nd Stage)	0-0 [0/0] / 25-55 [13.9/30.6]	0-0 [0/0] / 25-55 [13.9/30.6]	0-0 [0/0] / 25-55 [13.9/30.6]	0-0 [0/0] / 10-40 [5.6/22.2]
Steady State Efficiency (%)	81	81	81	81
No. Burners	14	14	14	12
No. Stages	2	2	2	2
Gas Connection Pipe Size in. [mm]	0.75 [19]	0.75 [19]	0.75 [19]	0.75 [19]
Compressor				
No./Type	2/Scroll	2/Scroll	2/Scroll	2/Scroll
Outdoor Sound Rating (dB)⁵				
	91	91	91	92
Outdoor Coil—Fin Type				
Tube Type	Louvered	Louvered	Louvered	Louvered
Tube Type	Rifled	Rifled	Rifled	Rifled
Tube Size in. [mm] OD	0.375 [9.5]	0.375 [9.5]	0.375 [9.5]	0.375 [9.5]
Face Area sq. ft. [sq. m]	53.3 [4.95]	53.3 [4.95]	53.3 [4.95]	53.3 [4.95]
Rows / FPI [FPcm]	2 / 22 [9]	2 / 22 [9]	2 / 22 [9]	2 / 22 [9]
Indoor Coil—Fin Type				
Tube Type	Louvered	Louvered	Louvered	Louvered
Tube Type	Rifled	Rifled	Rifled	Rifled
Tube Size in. [mm]	0.375 [9.5]	0.375 [9.5]	0.375 [9.5]	0.375 [9.5]
Face Area sq. ft. [sq. m]	26.67 [2.48]	26.67 [2.48]	26.67 [2.48]	26.67 [2.48]
Rows / FPI [FPcm]	3 / 13 [5]	3 / 13 [5]	3 / 13 [5]	4 / 15 [6]
Refrigerant Control	TX Valves	TX Valves	TX Valves	TX Valves
Drain Connection No./Size in. [mm]	1/1 [25.4]	1/1 [25.4]	1/1 [25.4]	1/1 [25.4]
Outdoor Fan—Type				
	Propeller	Propeller	Propeller	Propeller
No. Used/Diameter in. [mm]	6/24 [609.6]	6/24 [609.6]	6/24 [609.6]	6/24 [609.6]
Drive Type/No. Speeds	Direct/1	Direct/1	Direct/1	Direct/1
CFM [L/s]	19800 [9344]	19800 [9344]	19800 [9344]	19800 [9344]
No. Motors/HP	6 at 1/3 HP	6 at 1/3 HP	6 at 1/3 HP	6 at 1/3 HP
Motor RPM	1075	1075	1075	1075
Indoor Fan—Type				
	FC Centrifugal	FC Centrifugal	FC Centrifugal	FC Centrifugal
No. Used/Diameter in. [mm]	2/18x9 [457x229]	2/18x9 [457x229]	2/18x9 [457x229]	2/18x9 [457x229]
Drive Type/No. Speeds	Belt/Variable	Belt/Variable	Belt/Variable	Belt/Variable
No. Motors	1	1	1	1
Motor HP	5	7 1/2	7 1/2	7 1/2
Motor RPM	1725	1725	1725	1725
Motor Frame Size	184	213	213	213
Filter—Type				
	Disposable	Disposable	Disposable	Disposable
Furnished	Yes	Yes	Yes	Yes
(No.) Size Recommended in. [mm x mm x mm]	(8)2x25x20 [51x635x508]	(8)2x25x20 [51x635x508]	(8)2x25x20 [51x635x508]	(8)2x25x20 [51x635x508]
Refrigerant Charge Oz. (Sys. 1/Sys. 2) [g]				
	402/331 [11397/9384]	402/331 [11397/9384]	402/331 [11397/9384]	339/357 [9611/10121]
Weights				
Net Weight lbs. [kg]	2323 [1054]	2361 [1071]	2360 [1070]	2388 [1083]
Ship Weight lbs. [kg]	2423 [1099]	2461 [1116]	2460 [1116]	2488 [1129]

See Page 24 for Notes.

[] Designates Metric Conversions



NOM. SIZES 15-25 TONS [52.8-87.9 kW] MODELS

Model RKNL-C Series	C300CL40E	C300CM30E	C300CM40E	C300DL30E
Cooling Performance¹				CONTINUED →
Gross Cooling Capacity Btu [kW]	312,000 [91.42]	312,000 [91.42]	312,000 [91.42]	312,000 [91.42]
EER/SEER ²	10/NA	10/NA	10/NA	10/NA
Nominal CFM/AHRI Rated CFM [L/s]	10000/9475 [4719/4471]	10000/9475 [4719/4471]	10000/9475 [4719/4471]	10000/9475 [4719/4471]
AHRI Net Cooling Capacity Btu [kW]	294,000 [86.14]	294,000 [86.14]	294,000 [86.14]	294,000 [86.14]
Net Sensible Capacity Btu [kW]	214,100 [62.73]	214,100 [62.73]	214,100 [62.73]	214,100 [62.73]
Net Latent Capacity Btu [kW]	79,900 [23.41]	79,900 [23.41]	79,900 [23.41]	79,900 [23.41]
IEER ³	10.1	10.1	10.1	10.1
Net System Power kW	29.39	29.39	29.39	29.39
Heating Performance (Package Gas/Electric)⁴				
Heating Input Btu [kW] (1st Stage / 2nd Stage)	200,000/400,000 [58.6/117.2]	150,000/300,000 [43.95/87.9]	200,000/400,000 [58.6/117.2]	150,000/300,000 [43.95/87.9]
Heating Output Btu [kW] (1st Stage / 2nd Stage)	162,000/324,000 [47.47/94.93]	121,500/243,000 [35.6/71.2]	162,000/324,000 [47.47/94.93]	121,500/243,000 [35.6/71.2]
Temperature Rise Range °F [°C] (1st Stage / 2nd Stage)	0-0 [0/0] / 15-45 [8.3/25]	0-0 [0/0] / 10-40 [5.6/22.2]	0-0 [0/0] / 15-45 [8.3/25]	0-0 [0/0] / 10-40 [5.6/22.2]
Steady State Efficiency (%)	81	81	81	81
No. Burners	14	12	14	12
No. Stages	2	2	2	2
Gas Connection Pipe Size in. [mm]	0.75 [19]	0.75 [19]	0.75 [19]	0.75 [19]
Compressor				
No./Type	2/Scroll	2/Scroll	2/Scroll	2/Scroll
Outdoor Sound Rating (dB)⁵				
	92	92	92	92
Outdoor Coil—Fin Type				
Tube Type	Rifled	Rifled	Rifled	Rifled
Tube Size in. [mm] OD	0.375 [9.5]	0.375 [9.5]	0.375 [9.5]	0.375 [9.5]
Face Area sq. ft. [sq. m]	53.3 [4.95]	53.3 [4.95]	53.3 [4.95]	53.3 [4.95]
Rows / FPI [FPcm]	2 / 22 [9]	2 / 22 [9]	2 / 22 [9]	2 / 22 [9]
Indoor Coil—Fin Type				
Tube Type	Rifled	Rifled	Rifled	Rifled
Tube Size in. [mm]	0.375 [9.5]	0.375 [9.5]	0.375 [9.5]	0.375 [9.5]
Face Area sq. ft. [sq. m]	26.67 [2.48]	26.67 [2.48]	26.67 [2.48]	26.67 [2.48]
Rows / FPI [FPcm]	4 / 15 [6]	4 / 15 [6]	4 / 15 [6]	4 / 15 [6]
Refrigerant Control	TX Valves	TX Valves	TX Valves	TX Valves
Drain Connection No./Size in. [mm]	1/1 [25.4]	1/1 [25.4]	1/1 [25.4]	1/1 [25.4]
Outdoor Fan—Type				
No. Used/Diameter in. [mm]	6/24 [609.6]	6/24 [609.6]	6/24 [609.6]	6/24 [609.6]
Drive Type/No. Speeds	Direct/1	Direct/1	Direct/1	Direct/1
CFM [L/s]	19800 [9344]	19800 [9344]	19800 [9344]	19800 [9344]
No. Motors/HP	6 at 1/3 HP	6 at 1/3 HP	6 at 1/3 HP	6 at 1/3 HP
Motor RPM	1075	1075	1075	1075
Indoor Fan—Type				
No. Used/Diameter in. [mm]	2/18x9 [457x229]	2/18x9 [457x229]	2/18x9 [457x229]	2/18x9 [457x229]
Drive Type/No. Speeds	Belt/Variable	Belt/Variable	Belt/Variable	Belt/Variable
No. Motors	1	1	1	1
Motor HP	7 1/2	10	10	7 1/2
Motor RPM	1725	1725	1725	1725
Motor Frame Size	213	215	215	213
Filter—Type				
Furnished	Disposable	Disposable	Disposable	Disposable
(No.) Size Recommended in. [mm x mm x mm]	(8)2x25x20 [51x635x508]	(8)2x25x20 [51x635x508]	(8)2x25x20 [51x635x508]	(8)2x25x20 [51x635x508]
Refrigerant Charge Oz. (Sys. 1/Sys. 2) [g]				
	339/357 [9611/10121]	339/357 [9611/10121]	339/357 [9611/10121]	339/357 [9611/10121]
Weights				
Net Weight lbs. [kg]	2402 [1090]	2399 [1088]	2413 [1095]	2388 [1083]
Ship Weight lbs. [kg]	2502 [1135]	2499 [1134]	2513 [1140]	2488 [1129]

See Page 24 for Notes.

[] Designates Metric Conversions



NOM. SIZES 15-25 TONS [52.8-87.9 kW] MODELS

Model RKNL-C Series	C300DL40E	C300DM30E	C300DM40E	C300YL40E
Cooling Performance¹				
Gross Cooling Capacity Btu [kW]	312,000 [91.42]	312,000 [91.42]	312,000 [91.42]	312,000 [91.42]
EER/SEER ²	10/NA	10/NA	10/NA	10/NA
Nominal CFM/AHRI Rated CFM [L/s]	10000/9475 [4719/4471]	10000/9475 [4719/4471]	10000/9475 [4719/4471]	10000/9475 [4719/4471]
AHRI Net Cooling Capacity Btu [kW]	294,000 [86.14]	294,000 [86.14]	294,000 [86.14]	294,000 [86.14]
Net Sensible Capacity Btu [kW]	214,100 [62.73]	214,100 [62.73]	214,100 [62.73]	214,100 [62.73]
Net Latent Capacity Btu [kW]	79,900 [23.41]	79,900 [23.41]	79,900 [23.41]	79,900 [23.41]
IEER ³	10.1	10.1	10.1	10.1
Net System Power kW	29.39	29.39	29.39	29.39
Heating Performance (Package Gas/Electric)⁴				
Heating Input Btu [kW] (1st Stage / 2nd Stage)	200,000/400,000 [58.6/117.2]	150,000/300,000 [43.95/87.9]	200,000/400,000 [58.6/117.2]	200,000/400,000 [58.6/117.2]
Heating Output Btu [kW] (1st Stage / 2nd Stage)	162,000/324,000 [47.47/94.93]	121,500/243,000 [35.6/71.2]	162,000/324,000 [47.47/94.93]	162,000/324,000 [47.47/94.93]
Temperature Rise Range °F [°C] (1st Stage / 2nd Stage)	0-0 [0/0] / 15-45 [8.3/25]	0-0 [0/0] / 10-40 [5.6/22.2]	0-0 [0/0] / 15-45 [8.3/25]	0-0 [0/0] / 15-45 [8.3/25]
Steady State Efficiency (%)	81	81	81	81
No. Burners	14	12	14	14
No. Stages	2	2	2	2
Gas Connection Pipe Size in. [mm]	0.75 [19]	0.75 [19]	0.75 [19]	0.75 [19]
Compressor				
No./Type	2/Scroll	2/Scroll	2/Scroll	2/Scroll
Outdoor Sound Rating (dB)⁵				
	92	92	92	92
Outdoor Coil—Fin Type				
Tube Type	Rifled	Rifled	Rifled	Rifled
Tube Size in. [mm] OD	0.375 [9.5]	0.375 [9.5]	0.375 [9.5]	0.375 [9.5]
Face Area sq. ft. [sq. m]	53.3 [4.95]	53.3 [4.95]	53.3 [4.95]	53.3 [4.95]
Rows / FPI [FPcm]	2 / 22 [9]	2 / 22 [9]	2 / 22 [9]	2 / 22 [9]
Indoor Coil—Fin Type				
Tube Type	Rifled	Rifled	Rifled	Rifled
Tube Size in. [mm]	0.375 [9.5]	0.375 [9.5]	0.375 [9.5]	0.375 [9.5]
Face Area sq. ft. [sq. m]	26.67 [2.48]	26.67 [2.48]	26.67 [2.48]	26.67 [2.48]
Rows / FPI [FPcm]	4 / 15 [6]	4 / 15 [6]	4 / 15 [6]	4 / 15 [6]
Refrigerant Control	TX Valves	TX Valves	TX Valves	TX Valves
Drain Connection No./Size in. [mm]	1/1 [25.4]	1/1 [25.4]	1/1 [25.4]	1/1 [25.4]
Outdoor Fan—Type				
No. Used/Diameter in. [mm]	6/24 [609.6]	6/24 [609.6]	6/24 [609.6]	6/24 [609.6]
Drive Type/No. Speeds	Direct/1	Direct/1	Direct/1	Direct/1
CFM [L/s]	19800 [9344]	19800 [9344]	19800 [9344]	19800 [9344]
No. Motors/HP	6 at 1/3 HP	6 at 1/3 HP	6 at 1/3 HP	6 at 1/3 HP
Motor RPM	1075	1075	1075	1075
Indoor Fan—Type				
No. Used/Diameter in. [mm]	2/18x9 [457x229]	2/18x9 [457x229]	2/18x9 [457x229]	2/18x9 [457x229]
Drive Type/No. Speeds	Belt/Variable	Belt/Variable	Belt/Variable	Belt/Variable
No. Motors	1	1	1	1
Motor HP	7 1/2	10	10	7 1/2
Motor RPM	1725	1725	1725	1725
Motor Frame Size	213	215	215	213
Filter—Type				
Furnished	Yes	Yes	Yes	Yes
(No.) Size Recommended in. [mm x mm x mm]	(8)2x25x20 [51x635x508]	(8)2x25x20 [51x635x508]	(8)2x25x20 [51x635x508]	(8)2x25x20 [51x635x508]
Refrigerant Charge Oz. (Sys. 1/Sys. 2) [g]				
	339/357 [9611/10121]	339/357 [9611/10121]	339/357 [9611/10121]	339/357 [9611/10121]
Weights				
Net Weight lbs. [kg]	2402 [1090]	2399 [1088]	2413 [1095]	2422 [1099]
Ship Weight lbs. [kg]	2502 [1135]	2499 [1134]	2513 [1140]	2522 [1144]

CONTINUED →

See Page 24 for Notes.

[] Designates Metric Conversions

**NOM. SIZES 15-25 TONS [52.8-87.9 kW] MODELS**

Model RKNL-C Series	C300YM40E
Cooling Performance¹	
Gross Cooling Capacity Btu [kW]	312,000 [91.42]
EER/SEER ²	10/NA
Nominal CFM/AHRI Rated CFM [L/s]	10000/9475 [4719/4471]
AHRI Net Cooling Capacity Btu [kW]	294,000 [86.14]
Net Sensible Capacity Btu [kW]	214,100 [62.73]
Net Latent Capacity Btu [kW]	79,900 [23.41]
IEER ³	10.1
Net System Power kW	29.39
Heating Performance (Package Gas/Electric)⁴	
Heating Input Btu [kW] (1st Stage / 2nd Stage)	200,000/400,000 [58.6/117.2]
Heating Output Btu [kW] (1st Stage / 2nd Stage)	162,000/324,000 [47.47/94.93]
Temperature Rise Range °F [°C] (1st Stage / 2nd Stage)	0-0 [0/0] / 15-45 [8.3/25]
Steady State Efficiency (%)	81
No. Burners	14
No. Stages	2
Gas Connection Pipe Size in. [mm]	0.75 [19]
Compressor	
No./Type	2/Scroll
Outdoor Sound Rating (dB)⁵	
	92
Outdoor Coil—Fin Type	
Tube Type	Rifled
Tube Size in. [mm] OD	0.375 [9.5]
Face Area sq. ft. [sq. m]	53.3 [4.95]
Rows / FPI [FPcm]	2 / 22 [9]
Indoor Coil—Fin Type	
Tube Type	Rifled
Tube Size in. [mm]	0.375 [9.5]
Face Area sq. ft. [sq. m]	26.67 [2.48]
Rows / FPI [FPcm]	4 / 15 [6]
Refrigerant Control	TX Valves
Drain Connection No./Size in. [mm]	1/1 [25.4]
Outdoor Fan—Type	
	Propeller
No. Used/Diameter in. [mm]	6/24 [609.6]
Drive Type/No. Speeds	Direct/1
CFM [L/s]	19800 [9344]
No. Motors/HP	6 at 1/3 HP
Motor RPM	1075
Indoor Fan—Type	
	FC Centrifugal
No. Used/Diameter in. [mm]	2/18x9 [457x229]
Drive Type/No. Speeds	Belt/Variable
No. Motors	1
Motor HP	10
Motor RPM	1725
Motor Frame Size	215
Filter—Type	
	Disposable
Furnished	Yes
(No.) Size Recommended in. [mm x mm x mm]	(8)2x25x20 [51x635x508]
Refrigerant Charge Oz. (Sys. 1/Sys. 2) [g]	
	339/357 [9611/10121]
Weights	
Net Weight lbs. [kg]	2433 [1104]
Ship Weight lbs. [kg]	2533 [1149]

See Page 24 for Notes.

[] Designates Metric Conversions

NOTES:

1. Cooling Performance is rated at 95° F ambient, 80° F entering dry bulb, 67° F entering wet bulb. Gross capacity does not include the effect of fan motor heat. AHRI capacity is net and includes the effect of fan motor heat. Units are suitable for operation to $\pm 20\%$ of nominal cfm. Units are certified in accordance with the Unitary Air Conditioner Equipment certification program, which is based on AHRI Standard 210/240 or 340/360.
2. EER and/or SEER are rated at AHRI conditions and in accordance with DOE test procedures.
3. Integrated Energy Efficiency Ratio (IEER) is rated in accordance with AHRI Standard 210/240 or 360.
4. Heating Performance limit settings and rating data were established and approved under laboratory test conditions using American National Standard Institute standards. Ratings shown are for elevations up to 2000 feet. For elevations above 2000 feet, ratings should be reduced at the rate of 4% for each 1000 feet above sea level.
5. Outdoor Sound Rating shown is tested in accordance with AHRI Standard 270.
6. 25 ton model (C300) is outside the scope of AHRI Standard 340/360.



SYSTEMS PERFORMANCE—RKNL-C SERIES

GROSS SYSTEMS PERFORMANCE DATA—C180

		ENTERING INDOOR AIR @ 80°F [26.7°C] dbE ①									
wbE		71°F [21.7°C]			67°F [19.4°C]			63°F [17.2°C]			
CFM [L/s]		7200 [3398]	5900 [2784]	4800 [2265]	7200 [3398]	5900 [2784]	4800 [2265]	7200 [3398]	5900 [2784]	4800 [2265]	
DR ①		.04	.08	.13	.04	.08	.13	.04	.08	.13	
OUTDOOR DRY BULB TEMPERATURE °F [°C]	75 [23.9]	Total BTUH [kW] Sens BTUH [kW] Power	226.5 [66.4] 148.8 [43.6] 12.6	217.8 [63.8] 126.2 [37.0] 12.3	210.4 [61.7] 108.5 [31.8] 12.1	214.3 [62.8] 174.1 [51.0] 12.4	206.0 [60.4] 149.6 [43.9] 12.2	199.0 [58.3] 130.2 [38.2] 12.0	206.3 [60.5] 193.4 [56.7] 12.2	198.4 [58.1] 167.5 [49.1] 12.0	191.7 [56.2] 146.8 [43.0] 11.8
	80 [26.7]	Total BTUH [kW] Sens BTUH [kW] Power	222.2 [65.1] 146.6 [43.0] 13.1	213.6 [62.6] 124.3 [36.4] 12.9	206.4 [60.5] 106.9 [31.3] 12.7	209.9 [61.5] 171.9 [50.4] 13.0	201.8 [59.1] 147.8 [43.3] 12.7	195.0 [57.1] 128.7 [37.7] 12.5	202.0 [59.2] 191.3 [56.1] 12.8	194.2 [56.9] 165.7 [48.6] 12.6	187.6 [55.0] 145.3 [42.6] 12.4
	85 [29.4]	Total BTUH [kW] Sens BTUH [kW] Power	217.5 [63.7] 144.1 [42.2] 13.8	209.1 [61.3] 122.3 [35.9] 13.5	202.0 [59.2] 105.2 [30.8] 13.3	205.3 [60.2] 169.5 [49.7] 13.6	197.3 [57.8] 145.7 [42.7] 13.4	190.7 [55.9] 127.0 [37.2] 13.1	197.3 [57.8] 188.8 [55.3] 13.5	189.7 [55.6] 163.6 [48.0] 13.2	183.3 [53.7] 143.5 [42.1] 13.0
	90 [32.2]	Total BTUH [kW] Sens BTUH [kW] Power	212.5 [62.3] 141.4 [41.5] 14.5	204.3 [59.9] 120.0 [35.2] 14.2	197.4 [57.9] 103.3 [30.3] 14.0	200.2 [58.7] 166.7 [48.9] 14.3	192.5 [56.4] 143.5 [42.1] 14.0	186.0 [54.5] 125.1 [36.7] 13.8	192.3 [56.4] 186.2 [54.6] 14.2	184.9 [54.2] 161.4 [47.3] 13.9	178.6 [52.3] 141.6 [41.5] 13.7
	95 [35]	Total BTUH [kW] Sens BTUH [kW] Power	207.2 [60.7] 138.5 [40.6] 15.2	199.2 [58.4] 117.6 [34.5] 14.9	192.4 [56.4] 101.2 [29.7] 14.7	194.9 [57.1] 163.9 [48.0] 15.1	187.4 [54.9] 141.1 [41.4] 14.8	181.0 [53.0] 123.0 [36.1] 14.5	187.0 [54.8] 183.3 [53.7] 14.9	179.8 [52.7] 159.0 [46.6] 14.6	173.7 [50.9] 139.6 [40.9] 14.4
	100 [37.8]	Total BTUH [kW] Sens BTUH [kW] Power	201.5 [59.1] 135.4 [39.7] 16.0	193.7 [56.8] 115.0 [33.7] 15.7	187.2 [54.9] 99.1 [29.1] 15.4	189.2 [55.4] 160.7 [47.1] 15.9	181.9 [53.3] 138.4 [40.6] 15.6	175.8 [51.5] 120.8 [35.4] 15.3	181.3 [53.1] 180.1 [52.8] 15.7	174.3 [51.1] 156.3 [45.8] 15.4	168.4 [49.4] 137.3 [40.2] 15.1
	105 [40.6]	Total BTUH [kW] Sens BTUH [kW] Power	195.5 [57.3] 132.0 [38.7] 16.9	188.0 [55.1] 112.2 [32.9] 16.5	181.6 [53.2] 96.6 [28.3] 16.3	183.2 [53.7] 157.3 [46.1] 16.7	176.2 [51.6] 135.6 [39.8] 16.4	170.2 [49.9] 118.3 [34.7] 16.1	175.3 [51.4] 175.3 [51.4] 16.5	168.5 [49.4] 153.4 [45.0] 16.2	162.8 [47.7] 134.8 [39.5] 16.0
	110 [43.3]	Total BTUH [kW] Sens BTUH [kW] Power	189.2 [55.4] 128.4 [37.6] 17.8	181.9 [53.3] 109.1 [32.0] 17.4	175.7 [51.5] 93.9 [27.5] 17.1	176.9 [51.8] 153.7 [45.1] 17.6	170.1 [49.9] 132.6 [38.9] 17.3	164.3 [48.2] 115.8 [33.9] 17.0	169.0 [49.5] 169.0 [49.5] 17.5	162.5 [47.6] 150.5 [44.1] 17.1	156.9 [46.0] 132.3 [38.8] 16.8
	115 [46.1]	Total BTUH [kW] Sens BTUH [kW] Power	182.5 [53.5] 124.5 [36.5] 18.7	175.5 [51.4] 105.9 [31.0] 18.4	169.5 [49.7] 91.2 [26.7] 18.1	170.2 [49.9] 149.9 [43.9] 18.6	163.7 [48.0] 129.4 [37.9] 18.2	158.1 [46.3] 113.0 [33.1] 17.9	162.3 [47.6] 162.3 [47.6] 18.4	156.0 [45.7] 147.2 [43.2] 18.1	150.8 [44.2] 129.6 [38.0] 17.8

GROSS SYSTEMS PERFORMANCE DATA—C210

		ENTERING INDOOR AIR @ 80°F [26.7°C] dbE ①									
wbE		71°F [21.7°C]			67°F [19.4°C]			63°F [17.2°C]			
CFM [L/s]		8400 [3964]	7025 [3315]	5600 [2643]	8400 [3964]	7025 [3315]	5600 [2643]	8400 [3964]	7025 [3315]	5600 [2643]	
DR ①		.06	.09	.13	.06	.09	.13	.06	.09	.13	
OUTDOOR DRY BULB TEMPERATURE °F [°C]	75 [23.9]	Total BTUH [kW] Sens BTUH [kW] Power	258.4 [75.7] 193.9 [56.8] 13.0	249.5 [73.1] 168.8 [49.5] 12.8	240.3 [70.4] 144.5 [42.4] 12.5	244.1 [71.5] 224.6 [65.8] 12.8	235.7 [69.1] 197.4 [57.9] 12.6	227.0 [66.5] 170.8 [50.1] 12.4	231.9 [68.0] 231.9 [68.0] 12.7	223.9 [65.6] 217.1 [63.6] 12.4	215.7 [63.2] 189.1 [55.4] 12.2
	80 [26.7]	Total BTUH [kW] Sens BTUH [kW] Power	252.7 [74.1] 182.3 [53.4] 13.6	244.0 [71.5] 158.3 [46.4] 13.4	235.0 [68.9] 135.2 [39.6] 13.1	238.4 [69.9] 212.9 [62.4] 13.4	230.2 [67.5] 186.9 [54.8] 13.2	221.7 [65.0] 161.5 [47.3] 13.0	226.2 [66.3] 226.2 [66.3] 13.3	218.4 [64.0] 206.6 [60.6] 13.0	210.4 [61.7] 179.8 [52.7] 12.8
	85 [29.4]	Total BTUH [kW] Sens BTUH [kW] Power	246.7 [72.3] 171.9 [50.4] 14.2	238.2 [69.8] 149.0 [43.7] 14.0	229.4 [67.2] 126.9 [37.2] 13.7	232.4 [68.1] 202.7 [59.4] 14.1	224.4 [65.8] 177.7 [52.1] 13.8	216.1 [63.3] 153.4 [45.0] 13.6	220.2 [64.5] 220.2 [64.5] 13.9	212.6 [62.3] 197.4 [57.9] 13.7	204.8 [60.0] 171.7 [50.3] 13.4
	90 [32.2]	Total BTUH [kW] Sens BTUH [kW] Power	240.4 [70.5] 162.9 [47.8] 14.9	232.1 [68.0] 141.0 [41.3] 14.7	223.5 [65.5] 119.9 [35.1] 14.4	226.1 [66.3] 193.6 [56.7] 14.8	218.3 [64.0] 169.6 [49.7] 14.5	210.3 [61.6] 146.3 [42.9] 14.3	213.9 [62.7] 213.9 [62.7] 14.6	206.5 [60.5] 189.3 [55.5] 14.4	198.9 [58.3] 164.5 [48.2] 14.1
	95 [35]	Total BTUH [kW] Sens BTUH [kW] Power	233.8 [68.5] 155.3 [45.5] 15.7	225.7 [66.1] 134.2 [39.3] 15.4	217.4 [63.7] 114.0 [33.4] 15.1	219.5 [64.3] 186.0 [54.5] 15.5	212.0 [62.1] 162.9 [47.8] 15.2	204.1 [59.8] 140.3 [41.1] 15.0	207.3 [60.8] 207.0 [60.7] 15.3	200.2 [58.7] 182.6 [53.5] 15.1	192.8 [56.5] 158.6 [46.5] 14.8
	100 [37.8]	Total BTUH [kW] Sens BTUH [kW] Power	226.9 [66.5] 149.0 [43.7] 16.5	219.1 [64.2] 128.7 [37.7] 16.2	211.0 [61.8] 109.2 [32.0] 15.9	212.6 [62.3] 179.6 [52.6] 16.3	205.3 [60.2] 157.3 [46.1] 16.0	197.7 [57.9] 135.5 [39.7] 15.7	200.4 [58.7] 200.4 [58.7] 16.1	193.5 [56.7] 177.0 [51.9] 15.9	186.4 [54.6] 153.8 [45.1] 15.6
	105 [40.6]	Total BTUH [kW] Sens BTUH [kW] Power	219.7 [64.4] 143.9 [42.2] 17.3	212.1 [62.2] 124.3 [36.4] 17.0	204.3 [59.9] 105.5 [30.9] 16.7	205.4 [60.2] 174.6 [51.2] 17.1	198.3 [58.1] 152.9 [44.8] 16.8	191.0 [56.0] 131.8 [38.6] 16.5	193.2 [56.6] 193.2 [56.6] 17.0	186.5 [54.7] 172.7 [50.6] 16.7	179.7 [52.7] 150.2 [44.0] 16.4
	110 [43.3]	Total BTUH [kW] Sens BTUH [kW] Power	212.2 [62.2] 140.3 [41.1] 18.2	204.9 [60.1] 121.3 [35.6] 17.9	197.3 [57.8] 102.9 [30.2] 17.5	197.9 [58.0] 171.0 [50.1] 18.0	191.1 [56.0] 149.9 [43.9] 17.7	184.0 [53.9] 129.3 [37.9] 17.4	185.7 [54.4] 185.7 [54.4] 17.9	179.3 [52.5] 169.6 [49.7] 17.6	172.7 [50.6] 147.6 [43.3] 17.2
	115 [46.1]	Total BTUH [kW] Sens BTUH [kW] Power	204.4 [59.9] 138.1 [40.5] 19.1	197.3 [57.8] 119.4 [35.0] 18.8	190.1 [55.7] 101.6 [29.8] 18.5	190.1 [55.7] 168.7 [49.5] 19.0	183.5 [53.8] 148.0 [43.4] 18.6	176.8 [51.8] 127.9 [37.5] 18.3	177.9 [52.1] 177.9 [52.1] 18.8	171.8 [50.3] 167.8 [49.2] 18.5	165.4 [48.5] 146.1 [42.8] 18.1

DR —Depression ratio
dbE—Entering air dry bulb
wbE—Entering air wet bulb

Total —Total capacity x 1000 BTUH
Sens —Sensible capacity x 1000 BTUH
Power—KW input

NOTES: ① When the entering air dry bulb is other than 80°F [27°C], adjust the sensible capacity from the table by adding $[1.10 \times \text{CFM} \times (1 - \text{DR}) \times (\text{dbE} - 80)]$.

[] Designates Metric Conversions



GROSS SYSTEMS PERFORMANCE DATA—C240

		ENTERING INDOOR AIR @ 80°F [26.7°C] dbE ①									
wbE		71°F [21.7°C]			67°F [19.4°C]			63°F [17.2°C]			
CFM [L/s]		9600 [4531]	7725 [3646]	6400 [3020]	9600 [4531]	7725 [3646]	6400 [3020]	9600 [4531]	7725 [3646]	6400 [3020]	
DR ①		.06	.11	.15	.06	.11	.15	.06	.11	.15	
OUTDOOR DRY BULB TEMPERATURE °F [°C]	75 [23.9]	Total BTUH [kW] Sens BTUH [kW] Power	283.5 [83.1] 187.4 [54.9] 15.4	271.5 [79.6] 156.3 [45.8] 15.1	263.0 [77.1] 136.0 [39.9] 14.9	269.6 [79.0] 220.5 [64.6] 15.3	258.2 [75.7] 186.7 [54.7] 15.0	250.2 [73.3] 164.4 [48.2] 14.7	258.7 [75.8] 245.6 [72.0] 15.1	247.8 [72.6] 209.7 [61.5] 14.8	240.0 [70.3] 185.7 [54.4] 14.6
	80 [26.7]	Total BTUH [kW] Sens BTUH [kW] Power	280.8 [82.3] 186.4 [54.6] 16.2	269.0 [78.8] 155.6 [45.6] 15.9	260.6 [76.4] 135.4 [39.7] 15.6	267.0 [78.2] 219.6 [64.4] 16.0	255.7 [74.9] 186.0 [54.5] 15.7	247.7 [72.6] 163.8 [48.0] 15.5	256.1 [75.1] 244.7 [71.7] 15.9	245.3 [71.9] 209.0 [61.3] 15.5	237.6 [69.6] 185.2 [54.3] 15.3
	85 [29.4]	Total BTUH [kW] Sens BTUH [kW] Power	277.4 [81.3] 184.9 [54.2] 16.7	265.7 [77.9] 154.4 [45.3] 16.7	257.4 [75.4] 134.4 [39.4] 16.4	263.5 [77.2] 218.1 [63.9] 16.9	252.4 [74.0] 184.8 [54.2] 16.5	244.5 [71.7] 162.7 [47.7] 16.3	252.6 [74.0] 243.1 [71.3] 16.7	242.0 [70.9] 207.8 [60.9] 16.3	234.4 [68.7] 184.2 [54.0] 16.1
	90 [32.2]	Total BTUH [kW] Sens BTUH [kW] Power	273.1 [80.0] 182.8 [53.6] 17.9	261.6 [76.7] 152.7 [44.8] 17.5	253.4 [74.3] 132.9 [39.0] 17.3	259.3 [76.0] 216.2 [63.4] 17.7	248.3 [72.8] 183.2 [53.7] 17.4	240.6 [70.5] 161.5 [47.3] 17.1	248.4 [72.8] 241.1 [70.7] 17.6	237.9 [69.7] 206.1 [60.4] 17.2	230.5 [67.6] 182.8 [53.6] 16.9
	95 [35]	Total BTUH [kW] Sens BTUH [kW] Power	268.1 [78.6] 180.2 [52.8] 18.8	256.7 [75.2] 150.5 [44.1] 18.4	248.7 [72.9] 131.1 [38.4] 18.2	254.2 [74.5] 213.5 [62.6] 18.7	243.5 [71.4] 181.1 [53.1] 18.3	235.9 [69.1] 159.6 [46.8] 18.0	243.3 [71.3] 238.6 [69.9] 18.5	233.0 [68.3] 204.0 [59.8] 18.1	225.8 [66.2] 181.0 [53.1] 17.8
	100 [37.8]	Total BTUH [kW] Sens BTUH [kW] Power	262.2 [76.8] 177.1 [51.9] 19.8	251.1 [73.6] 148.0 [43.4] 19.4	243.3 [71.3] 129.0 [37.8] 19.1	248.3 [72.8] 210.4 [61.7] 19.6	237.8 [69.7] 178.5 [52.3] 19.2	230.4 [67.5] 157.4 [46.1] 18.9	237.4 [69.6] 235.3 [69.0] 19.5	227.4 [66.6] 201.4 [59.0] 19.1	220.3 [64.6] 178.7 [52.4] 18.8
	105 [40.6]	Total BTUH [kW] Sens BTUH [kW] Power	255.5 [74.9] 173.4 [50.8] 20.8	244.7 [71.7] 145.0 [42.5] 20.4	237.1 [69.5] 126.4 [37.1] 20.1	241.6 [70.8] 206.6 [60.6] 20.7	231.4 [67.8] 175.4 [51.4] 20.2	224.2 [65.7] 154.7 [45.3] 19.9	230.7 [67.6] 230.7 [67.6] 20.5	221.0 [64.8] 198.4 [58.2] 20.1	214.1 [62.7] 176.2 [51.6] 19.8
	110 [43.3]	Total BTUH [kW] Sens BTUH [kW] Power	248.0 [72.7] 169.2 [49.6] 21.9	237.5 [69.6] 141.5 [41.5] 21.5	230.1 [67.4] 123.4 [36.2] 21.1	234.1 [68.6] 202.4 [59.3] 21.7	224.2 [65.7] 171.9 [50.4] 21.3	217.2 [63.7] 151.7 [44.5] 21.0	223.2 [65.4] 223.2 [65.4] 21.6	213.8 [62.7] 194.9 [57.1] 21.1	207.1 [60.7] 173.1 [50.7] 20.8
	115 [46.1]	Total BTUH [kW] Sens BTUH [kW] Power	239.6 [70.2] 164.3 [48.2] 23.1	229.5 [67.3] 137.5 [40.3] 22.6	222.3 [65.1] 119.9 [35.1] 22.2	225.8 [66.2] 197.7 [58.0] 22.9	216.2 [63.4] 168.0 [49.2] 22.4	209.5 [61.4] 148.4 [43.5] 22.1	214.9 [63.0] 214.9 [63.0] 22.7	205.8 [60.3] 191.0 [56.0] 22.2	199.4 [58.4] 169.8 [49.8] 21.9

GROSS SYSTEMS PERFORMANCE DATA—C300

		ENTERING INDOOR AIR @ 80°F [26.7°C] dbE ①									
wbE		71°F [21.7°C]			67°F [19.4°C]			63°F [17.2°C]			
CFM [L/s]		12000 [5663]	9475 [4472]	8000 [3776]	12000 [5663]	9475 [4472]	8000 [3776]	12000 [5663]	9475 [4472]	8000 [3776]	
DR ①		.02	.08	0.11	.02	.08	0.11	.02	.08	0.11	
OUTDOOR DRY BULB TEMPERATURE °F [°C]	75 [23.9]	Total BTUH [kW] Sens BTUH [kW] Power	376.4 [110.3] 251.6 [73.7] 20.8	359.0 [105.2] 206.4 [60.5] 20.3	348.9 [102.3] 182.0 [53.3] 20.0	358.0 [104.9] 294.2 [86.2] 20.5	341.5 [100.1] 245.2 [71.9] 20.0	331.8 [97.2] 218.4 [64.0] 19.7	347.0 [101.7] 326.2 [95.6] 20.2	330.9 [97.0] 274.0 [80.3] 19.7	321.6 [94.3] 245.5 [72.0] 19.5
	80 [26.7]	Total BTUH [kW] Sens BTUH [kW] Power	369.9 [108.4] 248.1 [72.7] 21.7	352.8 [103.4] 203.6 [59.7] 21.2	342.8 [100.5] 179.5 [52.6] 21.0	351.5 [103.0] 290.8 [85.2] 21.4	335.2 [98.2] 242.3 [71.0] 21.0	325.7 [95.5] 215.9 [63.3] 20.7	340.4 [99.8] 322.6 [94.6] 21.2	324.6 [95.1] 271.1 [79.5] 20.7	315.5 [92.5] 243.0 [71.2] 20.4
	85 [29.4]	Total BTUH [kW] Sens BTUH [kW] Power	362.5 [106.2] 244.2 [71.6] 22.8	345.7 [101.3] 200.4 [58.7] 22.2	335.9 [98.4] 176.8 [51.8] 21.9	344.1 [100.8] 286.8 [84.1] 22.5	328.2 [96.2] 239.2 [70.1] 22.0	318.9 [93.5] 213.2 [62.5] 21.7	333.0 [97.6] 318.6 [93.4] 22.2	317.6 [93.1] 268.0 [78.6] 21.7	308.6 [90.4] 240.2 [70.4] 21.4
	90 [32.2]	Total BTUH [kW] Sens BTUH [kW] Power	354.3 [103.8] 239.8 [70.3] 23.9	338.0 [99.1] 197.0 [57.7] 23.3	328.4 [96.2] 173.8 [50.9] 23.0	335.9 [98.4] 282.4 [82.8] 23.6	320.4 [93.9] 235.7 [69.1] 23.0	311.3 [91.2] 210.1 [61.6] 22.7	324.9 [95.2] 314.4 [92.2] 23.3	309.8 [90.8] 264.5 [77.5] 22.7	301.1 [88.2] 237.2 [69.5] 22.4
	95 [35]	Total BTUH [kW] Sens BTUH [kW] Power	345.4 [101.2] 235.2 [68.9] 25.0	329.4 [96.5] 193.2 [56.6] 24.4	320.1 [93.8] 170.5 [50.0] 24.1	327.0 [95.8] 277.8 [81.4] 24.7	311.9 [91.4] 232.0 [68.0] 24.1	303.1 [88.8] 207.0 [60.7] 23.8	315.9 [92.6] 309.7 [90.8] 24.4	301.3 [88.3] 260.8 [76.4] 23.9	292.8 [85.8] 234.0 [68.6] 23.5
	100 [37.8]	Total BTUH [kW] Sens BTUH [kW] Power	335.7 [98.4] 230.3 [67.5] 26.2	320.2 [93.8] 189.3 [55.5] 25.6	311.1 [91.2] 167.1 [49.0] 25.3	317.3 [93.0] 272.9 [80.0] 25.9	302.6 [88.7] 228.0 [66.8] 25.3	294.1 [86.2] 203.6 [59.7] 25.0	306.2 [89.7] 304.7 [89.3] 25.6	292.1 [85.6] 256.9 [75.3] 25.1	283.8 [83.2] 230.5 [67.6] 24.7
	105 [40.6]	Total BTUH [kW] Sens BTUH [kW] Power	325.2 [95.3] 224.9 [65.9] 27.5	310.2 [90.9] 185.0 [54.2] 26.9	301.4 [88.3] 163.4 [47.9] 26.5	306.8 [89.9] 267.5 [78.4] 27.2	292.6 [85.8] 223.7 [65.6] 26.6	284.3 [83.3] 199.8 [58.6] 26.2	295.7 [86.7] 295.7 [86.7] 26.9	282.0 [82.6] 252.5 [74.0] 26.3	274.1 [80.3] 226.8 [66.5] 25.9
	110 [43.3]	Total BTUH [kW] Sens BTUH [kW] Power	313.9 [92.0] 219.3 [64.3] 28.9	299.4 [87.7] 180.5 [52.9] 28.2	290.9 [85.3] 159.5 [46.8] 27.8	295.5 [86.6] 261.9 [76.8] 28.6	281.9 [82.6] 219.3 [64.3] 27.9	273.9 [80.3] 195.9 [57.4] 27.5	284.4 [83.3] 284.4 [83.4] 28.3	271.3 [79.5] 248.1 [72.7] 27.6	263.6 [77.3] 222.9 [65.3] 27.2
	115 [46.1]	Total BTUH [kW] Sens BTUH [kW] Power	301.8 [88.4] 213.2 [62.5] 30.3	287.9 [84.4] 175.7 [51.5] 29.6	279.7 [82.0] 155.3 [45.5] 29.2	283.4 [83.1] 255.8 [75.0] 30.0	270.4 [79.2] 214.5 [62.9] 29.3	262.7 [77.0] 191.8 [56.2] 28.9	272.4 [79.8] 272.4 [79.8] 29.7	259.8 [76.1] 243.3 [71.3] 29.0	252.4 [74.0] 218.8 [64.1] 28.6

DR —Depression ratio
dbE—Entering air dry bulb
wbE—Entering air wet bulb

Total —Total capacity x 1000 BTUH
Sens —Sensible capacity x 1000 BTUH
Power—KW input

NOTES: ① When the entering air dry bulb is other than 80°F [27°C], adjust the sensible capacity from the table by adding [1.10 x CFM x (1 - DR) x (dbE - 80)].

[] Designates Metric Conversions



AIRFLOW PERFORMANCE—15 TON [52.8 kW]—SIDEFLOW

Air Flow CFM (L/s)		External Static Pressure—Inches of Water [kPa]																			
		0.1 [0.02]	0.2 [0.05]	0.3 [0.07]	0.4 [0.10]	0.5 [0.12]	0.6 [0.15]	0.7 [0.17]	0.8 [0.20]	0.9 [0.22]	1.0 [0.25]	1.1 [0.27]	1.2 [0.30]	1.3 [0.32]	1.4 [0.35]	1.5 [0.37]	1.6 [0.40]	1.7 [0.42]	1.8 [0.45]	1.9 [0.47]	2.0 [0.50]
4800 [2265]	—	—	—	—	—	583 [1393]	608 [1508]	632 [1621]	656 [1732]	679 [1841]	701 [1947]	723 [2052]	744 [2154]	764 [2254]	785 [2326]	805 [2430]	825 [2537]	844 [2647]	863 [2761]	881 [2878]	897 [2995]
5000 [2345]	—	—	—	—	591 [1476]	616 [1593]	640 [1707]	663 [1820]	686 [1930]	708 [2038]	729 [2145]	750 [2248]	771 [2350]	791 [2450]	811 [2528]	830 [2640]	850 [2755]	868 [2873]	887 [2995]	904 [3118]	920 [3248]
5200 [2454]	—	—	—	—	575 [1442]	600 [1562]	624 [1681]	648 [1797]	671 [1911]	693 [2023]	715 [2133]	736 [2241]	757 [2346]	777 [2447]	797 [2520]	817 [2633]	836 [2749]	855 [2869]	874 [2992]	892 [3118]	909 [3248]
5400 [2548]	—	—	—	—	583 [1530]	608 [1652]	632 [1772]	655 [1890]	678 [2005]	701 [2119]	722 [2231]	743 [2340]	764 [2447]	784 [2552]	804 [2665]	823 [2784]	842 [2908]	861 [3039]	879 [3177]	897 [3324]	914 [3476]
5600 [2643]	—	—	—	—	592 [1621]	616 [1745]	640 [1866]	663 [1986]	686 [2104]	708 [2218]	729 [2331]	750 [2442]	770 [2551]	791 [2620]	810 [2735]	829 [2855]	849 [2987]	867 [3126]	885 [3274]	903 [3434]	920 [3602]
5800 [2737]	—	—	—	—	576 [1588]	601 [1715]	625 [1840]	649 [1964]	672 [2085]	694 [2204]	716 [2321]	737 [2436]	757 [2548]	778 [2654]	798 [2764]	817 [2878]	836 [2995]	855 [3116]	873 [3249]	891 [3386]	909 [3527]
6000 [2831]	—	—	—	—	585 [1683]	610 [1813]	634 [1940]	657 [2065]	680 [2187]	702 [2308]	724 [2426]	744 [2543]	765 [2657]	785 [2731]	805 [2856]	824 [2984]	843 [3116]	861 [3251]	879 [3389]	897 [3531]	914 [3676]
6200 [2926]	—	—	—	—	570 [1650]	595 [1783]	619 [1913]	643 [2042]	666 [2169]	688 [2293]	710 [2415]	731 [2535]	752 [2653]	773 [2728]	792 [2834]	811 [2934]	831 [3055]	850 [3180]	868 [3310]	886 [3435]	903 [3562]
6400 [3020]	—	—	—	—	579 [1750]	604 [1885]	628 [2017]	652 [2148]	674 [2276]	697 [2402]	718 [2526]	739 [2648]	760 [2767]	780 [2852]	800 [2933]	819 [3018]	838 [3106]	856 [3196]	875 [3288]	892 [3381]	909 [3476]
6600 [3114]	—	—	—	—	589 [1854]	614 [1991]	637 [2125]	661 [2257]	683 [2386]	705 [2514]	727 [2640]	748 [2763]	768 [2884]	788 [2984]	808 [3119]	827 [3258]	845 [3340]	863 [3426]	881 [3514]	899 [3603]	916 [3694]
6800 [3209]	—	—	—	—	574 [1822]	599 [1961]	623 [2099]	647 [2235]	670 [2369]	692 [2500]	714 [2629]	735 [2756]	756 [2882]	776 [2984]	796 [3121]	815 [3262]	834 [3405]	853 [3552]	871 [3702]	888 [3856]	905 [4013]
7000 [3303]	—	—	—	—	584 [1930]	609 [2072]	633 [2211]	656 [2349]	679 [2484]	701 [2617]	723 [2748]	744 [2877]	764 [3003]	785 [3124]	804 [3255]	823 [3410]	842 [3559]	860 [3710]	878 [3865]	895 [4024]	912 [4185]
7200 [3398]	570 [1897]	595 [2042]	619 [2185]	643 [2327]	666 [2466]	689 [2602]	711 [2737]	732 [2870]	753 [3000]	773 [3127]	793 [3270]	812 [3416]	831 [3566]	849 [3719]	868 [3875]	885 [4035]	902 [4198]	919 [4364]	—	—	—

NOTE: L-Drive left of bold line, M-Drive right of bold line.

Drive Package	L						M					
	1	2	3	4	5	6	1	2	3	4	5	6
Motor H.P. [W]	733	701	669	640	605	572	927	903	873	840	808	775
Blower Sheave	BK105H											
Motor Sheave	1VP-56											
Turns Open	840											
RPM	808											

NOTES: 1. Factory sheave settings are shown in bold type.

2. Do not set motor sheave below minimum turns open shown.

3. Re-adjustment of sheave required to achieve rated airflow at AHR1 minimum External Static Pressure.

4. Drive data shown is for horizontal airflow with dry coil. Add component resistance (below) to duct resistance to determine total External Static Pressure.

COMPONENT AIR RESISTANCE—15 TON [52.8 kW]

CFM [L/s]	Resistance — Inches of Water [kPa]												
	4800 [2265]	5000 [2360]	5200 [2454]	5400 [2549]	5600 [2643]	5800 [2737]	6000 [2832]	6200 [2926]	6400 [3020]	6600 [3115]	6800 [3209]	7000 [3304]	7200 [3398]
Wet Coil	0.03 [0.01]	0.04 [0.01]	0.05 [0.01]	0.06 [0.01]	0.06 [0.01]	0.07 [0.02]	0.08 [0.02]	0.09 [0.02]	0.10 [0.02]	0.10 [0.02]	0.11 [0.03]	0.12 [0.03]	0.13 [0.03]
Downflow	0.05 [0.01]	0.05 [0.01]	0.05 [0.01]	0.05 [0.01]	0.05 [0.01]	0.05 [0.01]	0.06 [0.01]	0.06 [0.01]	0.06 [0.01]	0.06 [0.01]	0.07 [0.02]	0.08 [0.02]	0.08 [0.02]
Downflow Economizer R.A. Damper Open	0.09 [0.02]	0.10 [0.02]	0.10 [0.02]	0.11 [0.03]	0.12 [0.03]	0.13 [0.03]	0.14 [0.03]	0.14 [0.03]	0.15 [0.04]	0.16 [0.04]	0.16 [0.04]	0.17 [0.04]	0.18 [0.04]
Horizontal Economizer R.A. Damper Open	0.00 [0.00]	0.01 [0.00]	0.01 [0.00]	0.02 [0.00]	0.02 [0.00]	0.03 [0.01]	0.03 [0.01]	0.04 [0.01]	0.04 [0.01]	0.05 [0.01]	0.05 [0.01]	0.06 [0.01]	0.06 [0.01]
Concentric Grill RXRN-AD80 or RXRN-AD81 & Transition RXMC-CJ07	0.21 [0.05]	0.25 [0.06]	0.28 [0.07]	0.32 [0.08]	0.35 [0.09]	0.39 [0.10]	0.43 [0.11]	0.46 [0.11]	0.50 [0.12]	0.54 [0.13]	0.57 [0.14]	0.61 [0.15]	0.64 [0.16]

NOTE: Add component resistance to duct resistance to determine total external static pressure.

AIRFLOW CORRECTION FACTORS—15 TON [52.8 kW]

ACTUAL—CFM [L/s]	4800 [2265]	5000 [2360]	5200 [2454]	5400 [2549]	5600 [2643]	5800 [2737]	6000 [2832]	6200 [2926]	6400 [3020]	6600 [3115]	6800 [3209]	7000 [3304]	7200 [3398]
TOTAL MBTUH	0.97	0.97	0.98	0.98	0.99	1.00	1.00	1.01	1.02	1.03	1.03	1.03	1.04
SENSIBLE MBTUH	0.87	0.90	0.92	0.94	0.97	0.99	1.02	1.04	1.06	1.09	1.11	1.14	1.16
POWER kW	0.98	0.98	0.99	0.99	0.99	1.00	1.00	1.00	1.01	1.01	1.01	1.02	1.02

NOTES: Multiply correction factor times gross performance data—resulting sensible capacity cannot exceed total capacity.

[] Designates Metric Conversions



ELECTRICAL DATA – RKNL-C SERIES										
		C180CL	C180CM	C180DL	C180DM	C180YL	C180YM	C210CL	C210CM	C210DL
Unit Information	Unit Operating Voltage Range	187-253	187-253	414-506	414-506	518-632	518-632	187-253	187-253	414-506
	Volts	208/230	208/230	460	460	575	575	208/230	208/230	460
	Minimum Circuit Ampacity	78/78	81/81	38	40	28	30	88/88	91/91	44
	Minimum Overcurrent Protection Device Size	90/90	90/90	45	45	30	35	100/100	100/100	50
	Maximum Overcurrent Protection Device Size	100/100	100/100	45	50	35	35	110/110	110/110	50
Compressor Motor	No.	2	2	2	2	2	2	2	2	2
	Volts	200/230	200/230	460	460	575	575	200/230	200/230	460
	Phase	3	3	3	3	3	3	3	3	3
	RPM	3450	3450	3450	3450	3450	3450	3450	3450	3450
	HP, Compressor 1	7	7	7	7	7	7	7 1/2	7 1/2	7 1/2
	Amps (RLA), Comp. 1	25/25	25/25	12.2	12.2	9	9	29.5/29.5	29.5/29.5	14.7
	Amps (LRA), Comp. 1	164/164	164/164	100	100	78	78	195/195	195/195	95
	HP, Compressor 2			7	7					7 1/2
	Amps (RLA), Comp. 2	25/25	25/25	12.2	12.2	9	9	29.5/29.5	29.5/29.5	14.7
	Amps (LRA), Comp. 2	164/164	164/164	100	100	78	78	195/195	195/195	95
Condenser Motor	No.	4	4	4	4	4	4	4	4	4
	Volts	208/230	208/230	460	460	575	575	208/230	208/230	460
	Phase	1	1	1	1	1	1	1	1	1
	HP	1/3	1/3	1/3	1/3	1/3	1/3	1/3	1/3	1/3
	Amps (FLA, each)	2.4/2.4	2.4/2.4	1.4	1.4	1	1	2.4/2.4	2.4/2.4	1.4
	Amps (LRA, each)	4.7/4.7	4.7/4.7	2.4	2.4	1.8	1.8	4.7/4.7	4.7/4.7	2.4
Evaporator Fan	No.	1	1	1	1	1	1	1	1	1
	Volts	208/230	208/230	460	460	575	575	208/230	208/230	460
	Phase	3	3	3	3	3	3	3	3	3
	HP	3	5	3	5	3	5	3	5	3
	Amps (FLA, each)	11.5/11.5	14.9/14.9	4.6	6.6	3.5	5.3	11.5/11.5	14.9/14.9	4.6
	Amps (LRA, each)	74.5/74.5	82.6/82.6	38.1	46.3	20	39.4	74.5/74.5	82.6/82.6	38.1



ELECTRICAL DATA – RKNL-C SERIES										
		C210DM	C210YL	C210YM	C240CL	C240CM	C240CN	C240DL	C240DM	C240DN
Unit Information	Unit Operating Voltage Range	414-506	518-632	518-632	187-253	187-253	187-253	414-506	414-506	414-506
	Volts	460	575	575	208/230	208/230	208/230	460	460	460
	Minimum Circuit Ampacity	46	35	37	101/101	109/109	109/109	52	56	56
	Minimum Overcurrent Protection Device Size	50	40	40	110/110	125/125	125/125	60	60	60
	Maximum Overcurrent Protection Device Size	50	45	45	125/125	125/125	125/125	60	70	70
Compressor Motor	No.	2	2	2	2	2	2	2	2	2
	Volts	460	575	575	200/230	200/230	200/230	460	460	460
	Phase	3	3	3	3	3	3	3	3	3
	RPM	3450	3450	3450	3450	3450	3450	3450	3450	3450
	HP, Compressor 1	7 1/2	7 1/2	7 1/2	10	10	10	10	10	10
	Amps (RLA), Comp. 1	14.7	12.2	12.2	33.3/33.3	33.3/33.3	33.3/33.3	17.9	17.9	17.9
	Amps (LRA), Comp. 1	95	80	80	239/239	239/239	239/239	125	125	125
	HP, Compressor 2	7 1/2	7 1/2	7 1/2	7 1/2	7 1/2	7 1/2	7 1/2	7 1/2	7 1/2
	Amps (RLA), Comp. 2	14.7	12.2	12.2	29.5/29.5	29.5/29.5	29.5/29.5	14.7	14.7	14.7
	Amps (LRA), Comp. 2	95	80	80	195/195	195/195	195/195	95	95	95
Condenser Motor	No.	4	4	4	6	6	6	6	6	6
	Volts	460	575	575	208/230	208/230	208/230	460	460	460
	Phase	1	1	1	1	1	1	1	1	1
	HP	1/3	1/3	1/3	1/3	1/3	1/3	1/3	1/3	1/3
	Amps (FLA, each)	1.4	1	1	2.4/2.4	2.4/2.4	2.4/2.4	1.4	1.4	1.4
	Amps (LRA, each)	2.4	1.8	1.8	4.7/4.7	4.7/4.7	4.7/4.7	2.4	2.4	2.4
Evaporator Fan	No.	1	1	1	1	1	1	1	1	1
	Volts	460	575	575	208/230	208/230	208/230	460	460	460
	Phase	3	3	3	3	3	3	3	3	3
	HP	5	3	5	5	7 1/2	7 1/2	5	7 1/2	7 1/2
	Amps (FLA, each)	6.6	3.5	5.3	14.7/14.7	23.1/23.1	23.1/23.1	6.6	9.6	9.6
	Amps (LRA, each)	46.3	20	39.4	82.6/82.6	136/136	136/136	46.3	67	67



ELECTRICAL DATA – RKNL-C SERIES										
		C240YL	C240YM	C240YN	C300CL	C300CM	C300DL	C300DM	C300YL	C300YM
Unit Information	Unit Operating Voltage Range	518-632	518-632	518-632	187-253	187-253	414-506	414-506	518-632	518-632
	Volts	575	575	575	208/230	208/230	460	460	575	575
	Minimum Circuit Ampacity	40	42	42	147/147	149/149	60	63	47	50
	Minimum Overcurrent Protection Device Size	45	50	50	175/175	175/175	70	70	60	60
	Maximum Overcurrent Protection Device Size	50	50	50	175/175	175/175	70	80	60	60
Compressor Motor	No.	2	2	2	2	2	2	2	2	2
	Volts	575	575	575	200/240	200/240	460	460	575	575
	Phase	3	3	3	3	3	3	3	3	3
	RPM	3450	3450	3450	3450	3450	3450	3450	3450	3450
	HP, Compressor 1	10	10	10	11 1/2	11 1/2	11 1/2	11 1/2	11 1/2	11 1/2
	Amps (RLA), Comp. 1	12.8	12.8	12.8	48.1/48.1	48.1/48.1	18.6	18.6	14.7	14.7
	Amps (LRA), Comp. 1	80	80	80	245/245	245/245	125	125	100	100
	HP, Compressor 2	7 1/2	7 1/2	7 1/2					11 1/2	11 1/2
	Amps (RLA), Comp. 2	12.2	12.2	12.2	48.1/48.1	48.1/48.1	18.6	18.6	14.7	14.7
	Amps (LRA), Comp. 2	80	80	80	245/245	245/245	125	125	100	100
Condenser Motor	No.	6	6	6	6	6	6	6	6	6
	Volts	575	575	575	208/230	208/230	460	460	575	575
	Phase	1	1	1	1	1	1	1	1	1
	HP	1/3	1/3	1/3	1/3	1/3	1/3	1/3	1/3	1/3
	Amps (FLA, each)	1	1	1	2.4/2.4	2/2	1.4	1.4	1	1
	Amps (LRA, each)	1.8	1.8	1.8	4.7/4.7	3.9/3.9	2.4	2.4	1.8	1.8
Evaporator Fan	No.	1	1	1	1	1	1	1	1	1
	Volts	575	575	575	208/230	208/230	460	460	575	575
	Phase	3	3	3	3	3	3	3	3	3
	HP	5	7 1/2	7 1/2	7 1/2	10	7 1/2	10	7 1/2	10
	Amps (FLA, each)	5.3	7.8	7.8	24.2/24.2	28.5/28.5	9.6	12.5	7.8	10
	Amps (LRA, each)	39.4	53.8	53.8	136/136	178/178	67	74.6	53.8	59.2

GAS HEAT / ELECTRIC COOLING PACKAGE

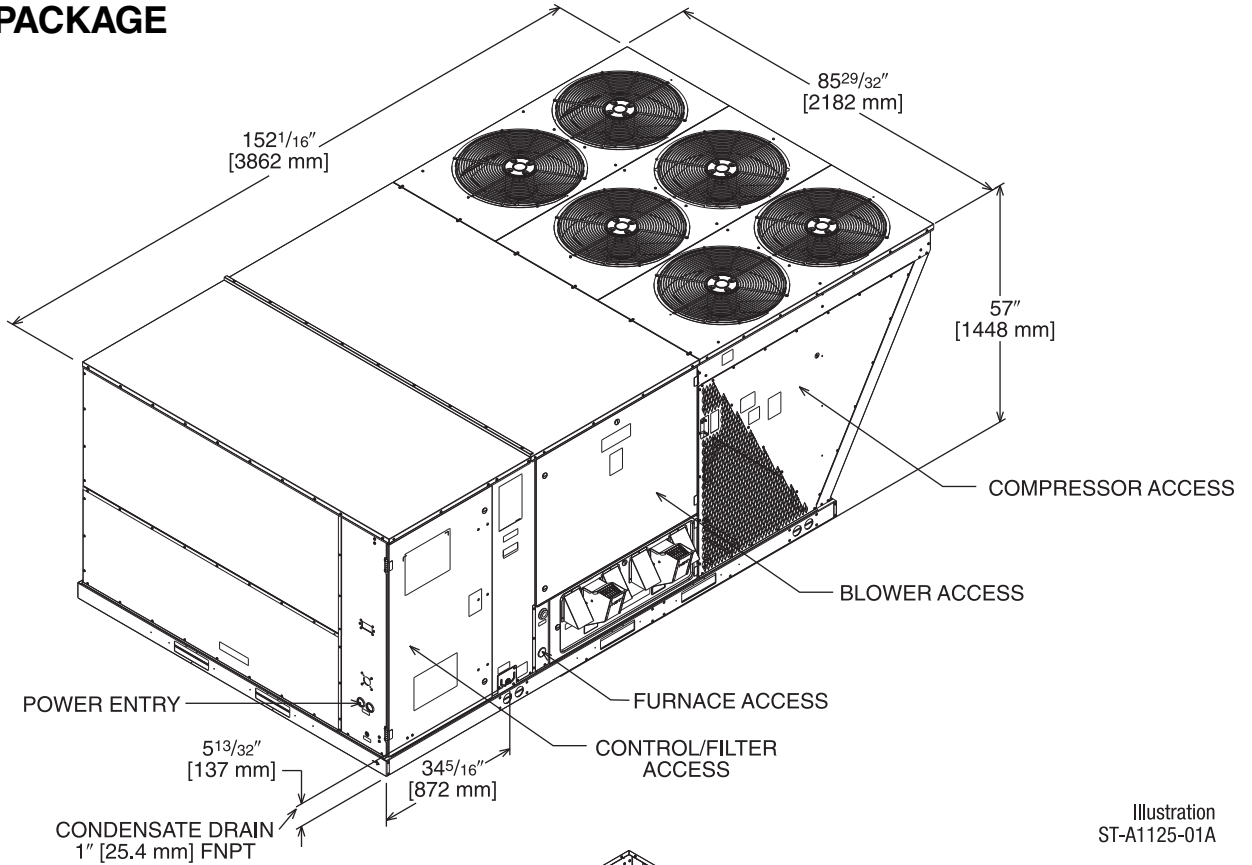
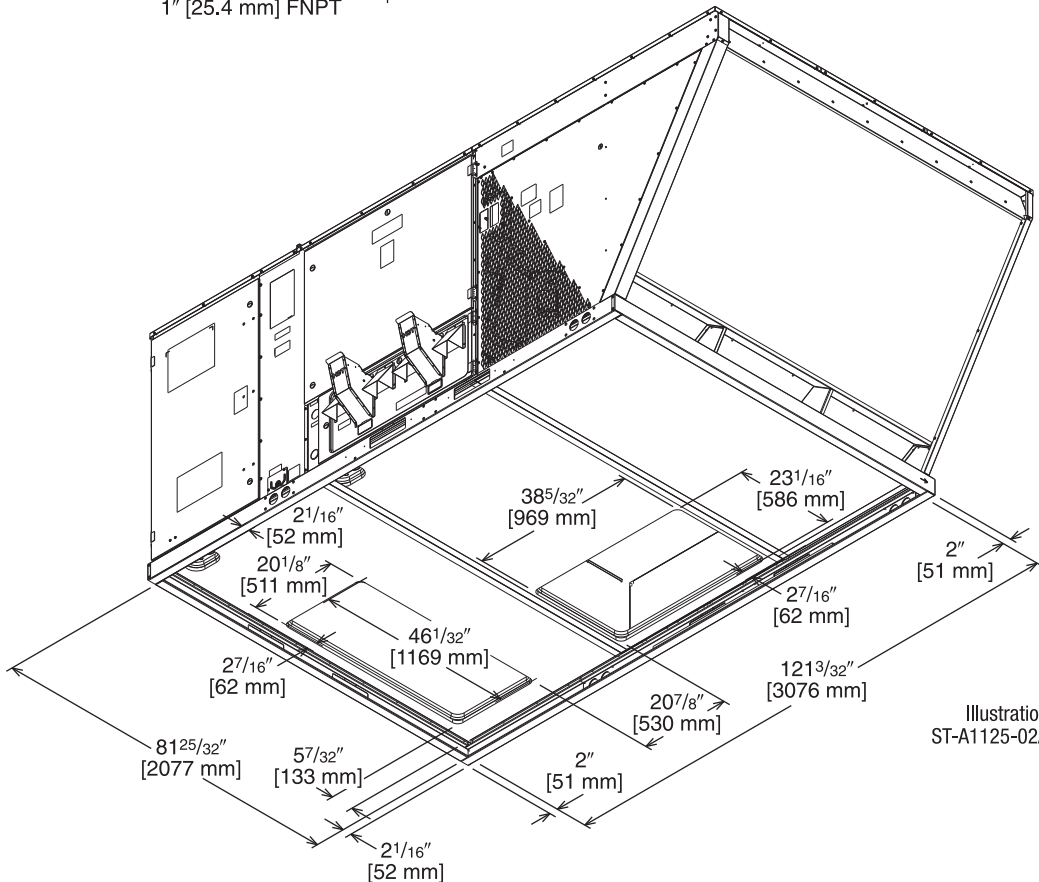

Illustration ST-A1125-01A



BOTTOM VIEW

Illustration ST-A1125-02A

[] Designates Metric Conversions

GAS HEAT / ELECTRIC COOLING PACKAGE

SUPPLY AND RETURN DIMENSIONS FOR HORIZONTAL APPLICATIONS

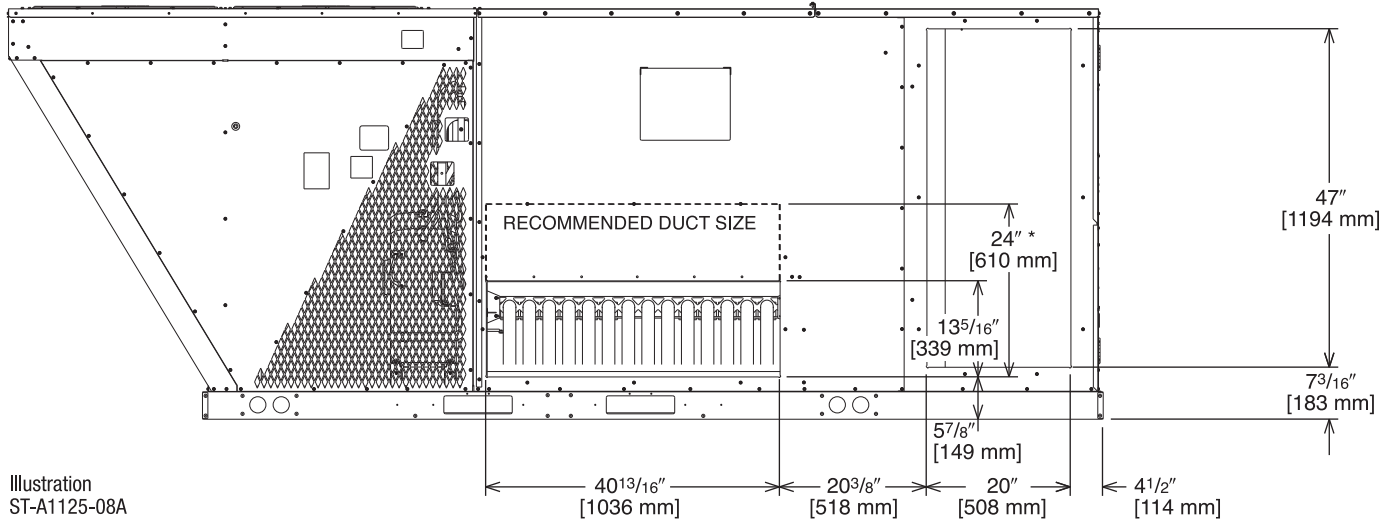

Illustration
ST-A1125-08A

* RECOMMENDED DUCT CONNECTION SIZE

DUCT SIDE VIEW (REAR)

SUPPLY AND RETURN DIMENSIONS FOR DOWNFLOW APPLICATIONS

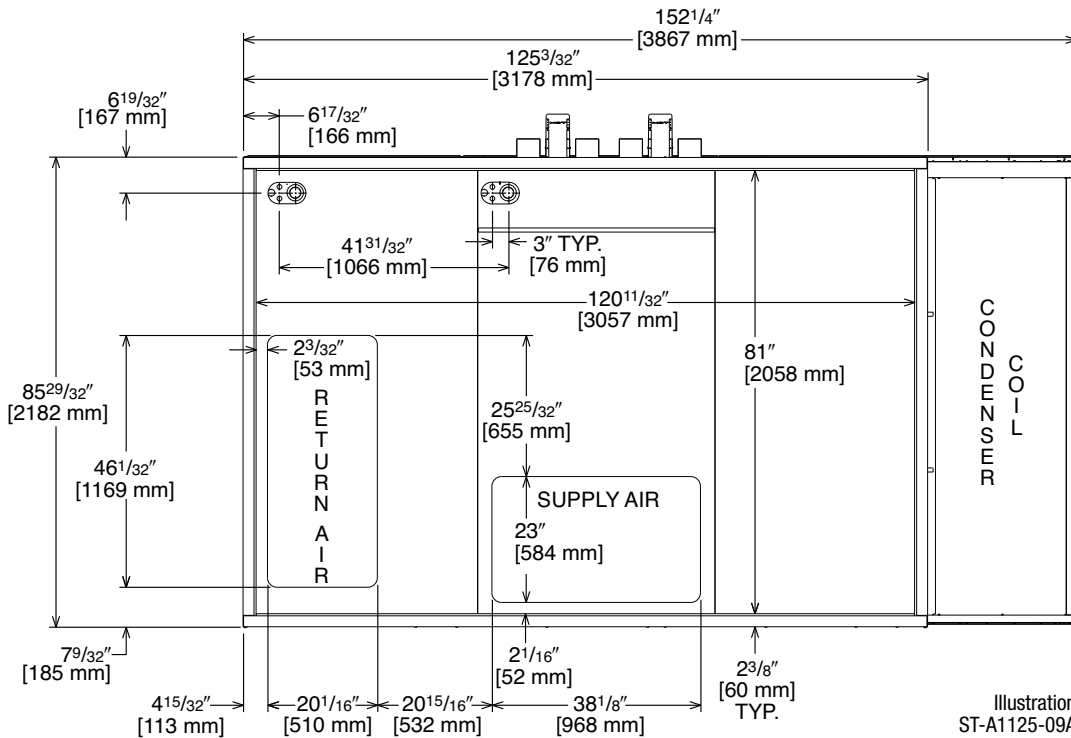

Illustration
ST-A1125-09A

BOTTOM VIEW

[] Designates Metric Conversions

UNIT DIMENSIONS GAS HEAT / ELECTRIC COOLING PACKAGE

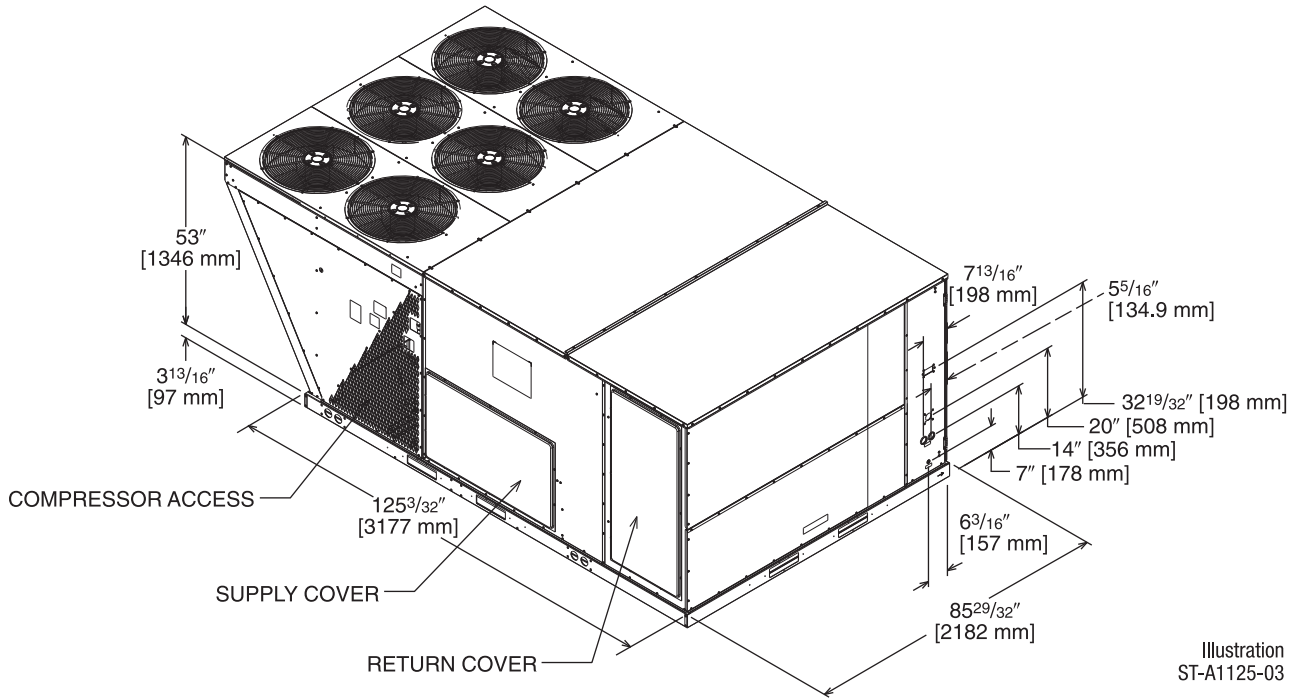
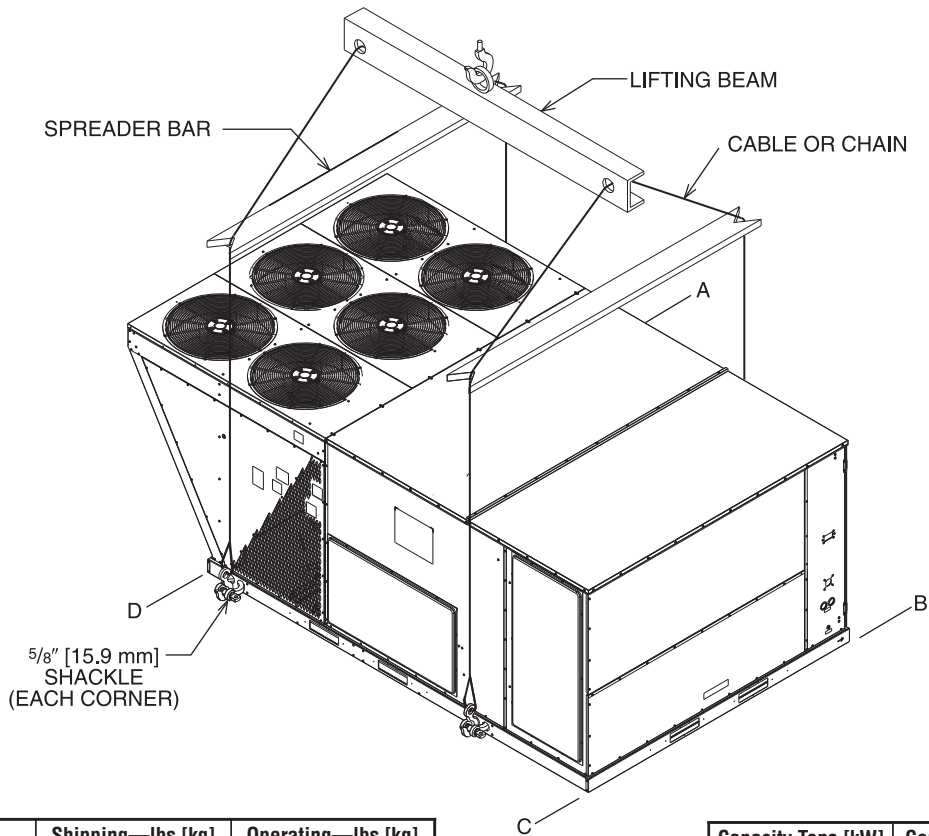

Illustration
ST-A1125-03



WEIGHTS

Accessory	Shipping—lbs [kg]	Operating—lbs [kg]
Economizer—Downflow	155 [70.31]	146 [66.22]
Economizer—Horizontal	165 [74.80]	155 [70.31]
Fresh Air Damper (Manual)	51 [23.13]	40 [18.14]
Fresh Air Damper (Motorized)	46 [20.87]	35 [15.88]
Roof Curb 14"	170 [77.11]	164 [74.39]

Capacity Tons [kW]	Corner Weights by Percentage			
	A	B	C	D
15-25 [52.8-87.9]	32%	27%	16%	24%

Corner weights measured at base of unit.

[] Designates Metric Conversions

SLAB INSTALLATION

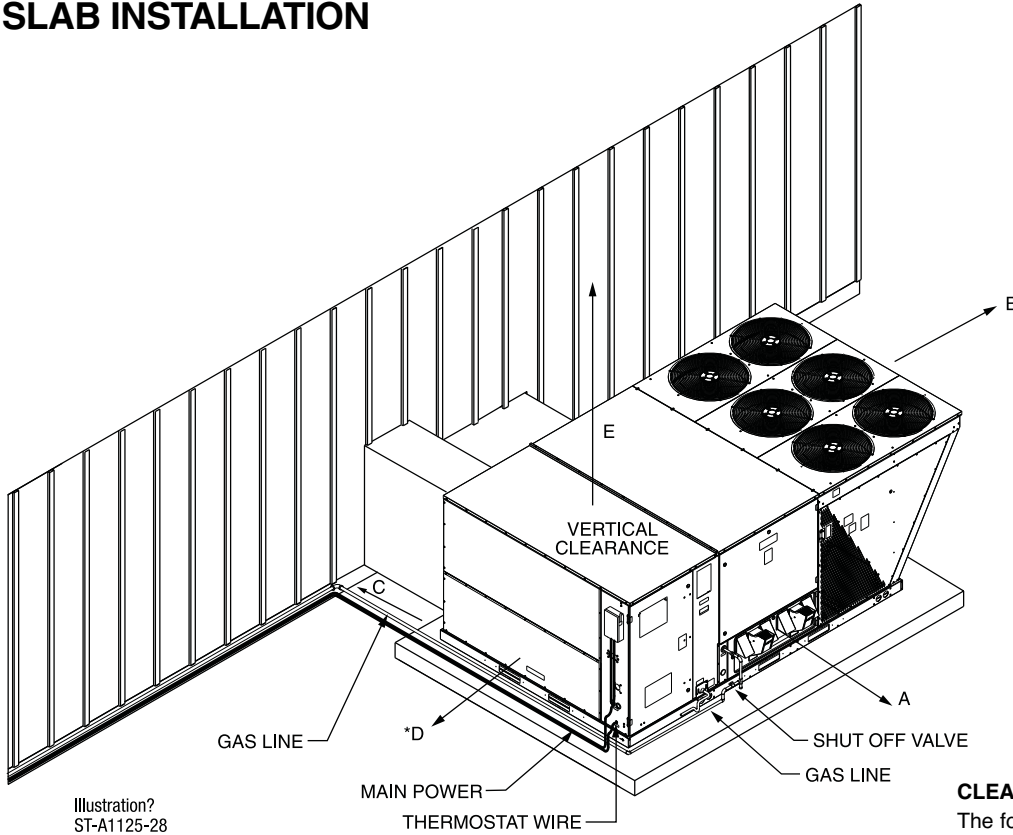

Illustration?
ST-A1125-28

CLEARANCES

The following minimum clearances are recommended for proper unit performance and serviceability.

Recommended Clearance In. [mm]	Location
80 [2032]	A - Front
18 [457]	B - Condenser Coil
+18 [457]	+C - Duct Side
*18 [457]	*D - Evaporator End
60 [1524]	E - Above
*Without Economizer, 48" [1219 mm] With Economizer +Without Horizontal Economizer, 42" [1067 mm] with Horizontal Economizer	

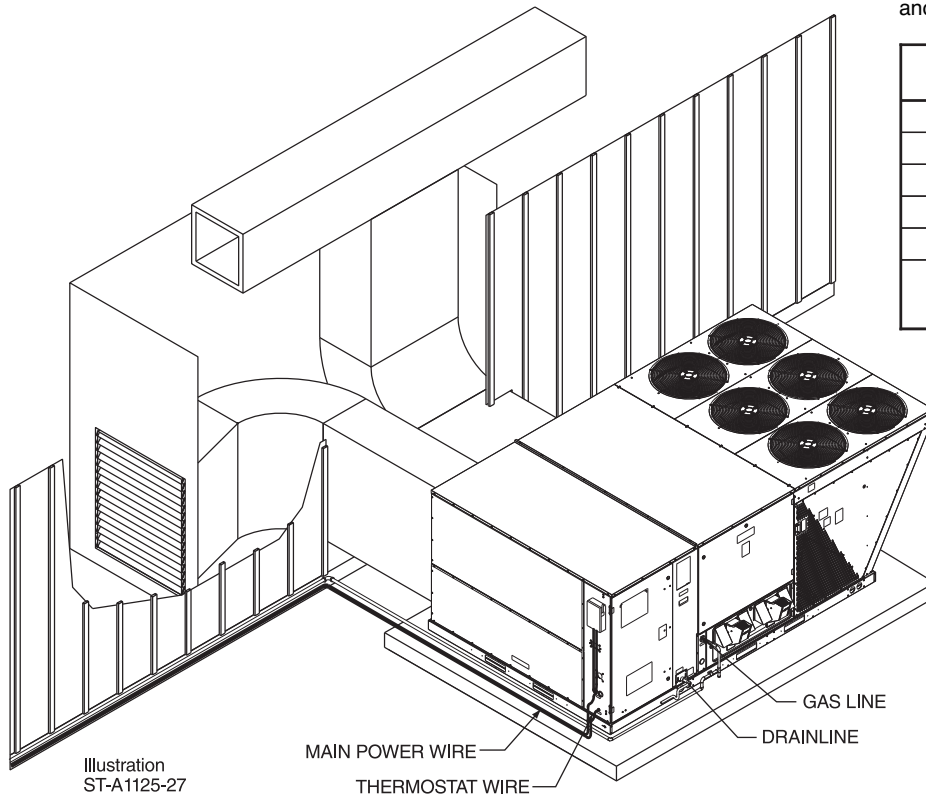

Illustration
ST-A1125-27

[] Designates Metric Conversions

FIELD INSTALLED ACCESSORY EQUIPMENT

Accessory	Model Number	Shipping Weight Lbs. [kg]	Installed Weight Lbs. [kg]	Factory Installation Available?
Thermostat	See Thermostat Specification Sheet (T22-001)			No
Downflow Economizer w/Single Enthalpy (DDC)	AXRD-PMCM3	277 [125.6]	168 [76.2]	Yes
Downflow Economizer w/Smoke Detector (DDC)	AXRD-SMCM3	280 [127.0]	171 [77.6]	Yes
Dual Enthalpy Kit	RXXR-AV03	1 [.5]	.5 [0.2]	No
Horizontal Economizer w/Single Enthalpy (DDC)	AXRD-RMCM3	333 [151.0]	301 [36.5]	No
Carbon Dioxide Sensor (Wall Mount)	RXXR-AR02	3 [1.4]	2 [1.0]	No
Power Exhaust (208/230V)	RXXR-BGF05C	119 [54.0]	59 [26.8]	No
Power Exhaust (460V)	RXXR-BGF05D	119 [54.0]	59 [26.8]	No
Power Exhaust (575V)	RXXR-BGF05Y	119 [54.0]	59 [26.8]	No
Manual Fresh Air Damper*	AXRF-KFA1	61 [27.7]	52 [23.6]	No
Motorized Kit for Manual Fresh Air Damper*	RXXR-AW03	42 [19.1]	35 [15.9]	No
Modulating Motor Kit w/position feedback for RXRF-KFA1	RXXR-AW05	45 [20.4]	38 [17.2]	No
Roofcurb, 14"	RXKG-CBH14	184 [83.5]	176 [79.8]	No
Roofcurb Adapter to RXRK-E56	RXXR-CJCE56	465 [210.9]	415 [88.2]	No
Roofcurb Adapter to RXKG-CAF14	RXXR-CJCF14	555 [251.7]	505 [29.1]	No
Concentric Diffuser (Step-Down, 18" x 36")	RXRN-AD81	310 [140.6]	157 [71.2]	No
Concentric Diffuser (Step-Down, 24" x 48")	RXRN-AD86	367 [166.5]	212 [96.2]	No
Concentric Diffuser (Step-Down, 28" x 60")	RXRN-AD88	410 [186.0]	370 [67.8]	No
Concentric Diffuser (Flush, 18" x 36")	RXRN-AD80	213 [96.6]	115 [52.2]	No
Downflow Transition (Rect. to Rect., 18" x 36")	RXMC-CJ07	81 [36.7]	74 [33.6]	No
Downflow Transition (Rect. to Rect., 24" x 48")	RXMC-CK08	81 [36.7]	74 [33.6]	No
Downflow Transition (Rect. to Rect., 28" x 60")	RXMC-CL09	81 [36.7]	74 [33.6]	No
Low-Ambient Control Kit (1 Per Compressor)	RXRZ-C02	3 [1.4]	2 [0.9]	Yes
Unwired Convenience Outlet	RXXR-AN01	2 [0.9]	1.5 [.7]	Yes
Unfused Service Disconnect+	RXXR-AP01	10 [4.5]	9 [4.1]	Yes
Comfort Alert (1 per compressor)	RXXR-AZ01	3 [1.4]	2 [0.9]	Yes
BACnet Communication Card	RXXR-AY01	1 [0.5]	1 [0.5]	No
LonWorks Communication Card	RXXR-AY02	1 [0.5]	1 [0.5]	No

*Motorized Kit and Manual Fresh Air Damper must be combined for a complete Motorized Outside Air Damper Selection.
 +Do not use on or RKNL-C300C voltage models.

[] Designates Metric Conversions

THERMOSTATS

100-Series *
Non-Programmable

200-Series *
Programmable

300-Series *
Deluxe
Programmable

500-Series *
Communicating/
Programmable

400-Series *
Special Applications/
Programmable

Brand	Unique Model Number Prefix	Descriptor (3 Characters)	Series (3 Characters)	System (2 Characters)	Type (2 Characters)
UHC	-	TST	101	GE	MS
UHC=Ruud		TST=Thermostat	100=Non-Programmable 200=Programmable 300=Deluxe Programmable 400=Special Applications/ Programmable 500=Communicating/ Programmable	GE=Gas/Oil/Electric HP=Heat Pump MD=Modulating Furnace DF=Dual Fuel UN=Universal AC/HP/GE CM=Communicating	SS=Single-Stage MS=Multi-Stage

* Photos are representative. Actual models may vary.

For detailed thermostat match-up information, see specification sheet form number T22-001.

FLUSH MOUNT ROOM TEMPERATURE SENSORS FOR NETWORKED DDC APPLICATIONS

ROOM TEMPERATURE SENSOR RHC-ZNS1
with **TIMED OVERRIDE BUTTON**

10kΩ room temperature sensor transmits room temperature to DDC system. Timed override button allows tenant to change from unoccupied temperature setpoint to occupied temperature setpoint for a preset time.

ROOM TEMPERATURE SENSOR RHC-ZNS2
with **TIMED OVERRIDE BUTTON** and **STATUS INDICATOR**

10kΩ room temperature sensor transmits room temperature to DDC system. Timed override button allows tenant to change from unoccupied temperature setpoint to occupied temperature setpoint for a preset time. Status Indicator Light transmits ALARM flash code to occupied space.

ROOM TEMPERATURE SENSOR RHC-ZNS3
with **SETPOINT ADJUSTMENT** and **TIMED OVERRIDE BUTTON**

10kΩ room temperature sensor with setpoint adjustment transmits room temperature to DDC system along with desired occupied room temperature setpoint. Timed override button allows tenant to change from unoccupied temperature setpoint to occupied temperature setpoint for a preset time.

COMMUNICATION CARDS

Field Installed



BACnet® COMMUNICATION CARD RXRX-AY01

The field installed BACnet® Communication Card allows the RTU-C unit controller to communicate with a third party building management system that supports the BACnet Application Specific Controller device profile. The BACnet® Communication Module plugs onto the unit RTU-C controller and allows communication between the RTU-C and the BACnet MSTP network.



LonWorks® COMMUNICATION CARD RXRX-AY02

The field installed LonWorks® Communication Card allows the RTU-C unit controller to communicate with a third party building management system that supports the LonMark Space Comfort Controller (SCC) functional profile or LonMark Discharge Air Controller (DAC) functional profile. The LonMark Communication Module plugs onto the RTU-C controller and allows communication between the RTU-C and a LonWorks Network.

ECONOMIZERS

Use to Select Factory Installed Options Only

AXRD-PMCM3—Single Enthalpy (Outdoor) with DDC

AXRD-SMCM3—Single Enthalpy (Outdoor) with Smoke Detector and DDC

RXXR-AV03—Dual Enthalpy Upgrade Kit

RXXR-AR02—Optional Wall-Mounted CO₂ Sensor

- Features **Honeywell** Controls
- Available Factory Installed or Field Accessory
- Gear Driven Direct Drive Actuator
- Fully Modulating (0-100%)
- Low Leakage Dampers
- Slip-In Design for Easy Installation
- Plug-In Polarized 12-pin and 4-pin Electrical Connections
- Pre-Configured—No Field Adjustments Necessary
- Standard Barometric Relief Damper
- Single Enthalpy with Dual Enthalpy Upgrade Kit Available
- CO₂ Input Sensor Available
- Field Assembled Hood Ships with Economizer
- Economizer Ships Complete for Downflow Duct Application.
- Optional Remote Minimum Position Potentiometer (270 ohm) (Honeywell #S963B1136) is available from Prostock.
- Field Installed Power Exhaust Available
- If connected to a Building Automation System (BAS), all economizer functions can be viewed on the (BAS) or 16 x 2 LCD screen
- If connected to thermostat, all economizer functions can be viewed on 16 x 2 character LCD screen

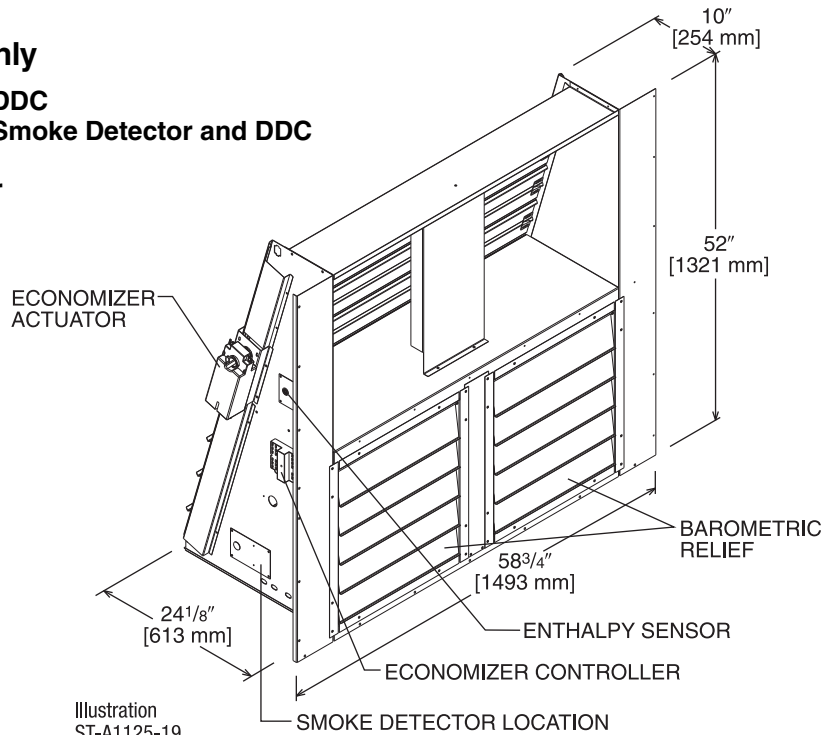

Illustration ST-A1125-19

TOLERANCE ±.125

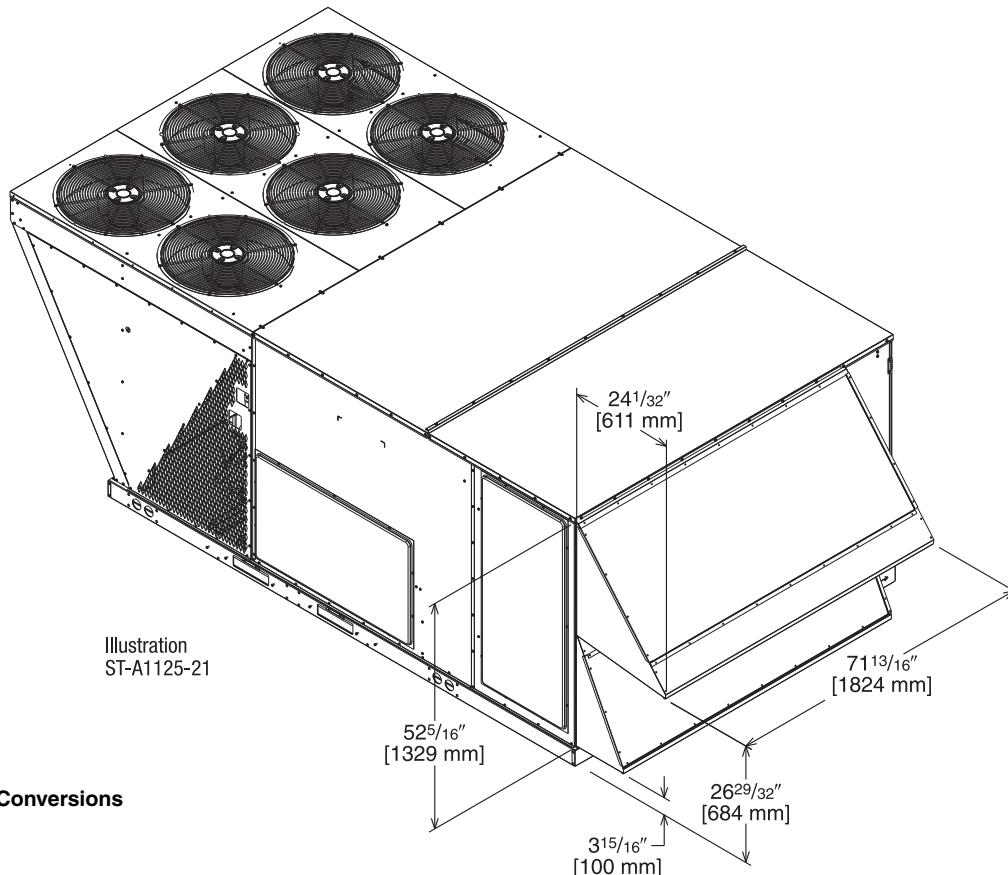

Illustration ST-A1125-21

[] Designates Metric Conversions

ECONOMIZER FOR HORIZONTAL DUCT INSTALLATION

Field Installed Only

AXRD-RMCM3—Single Enthalpy (Outdoor) with DDC
 RXXR-AV03—Dual Enthalpy Upgrade Kit
 RXXR-AR02—Wall-mounted CO₂ Sensor

- Features **Honeywell** Controls
- Available as a Field Installed Accessory Only
- Gear Driven Direct Drive Actuator
- Fully Modulating (0-100%)
- Low Leakage Dampers
- Slip-In Design for Easy Installation
- Plug-In Polarized 12-pin and 4-pin Electrical Connections
- Pre-Configured—No Field Adjustments Necessary
- Standard Barometric Relief Damper
- Single Enthalpy with Dual Enthalpy Upgrade Kit Available
- CO₂ Input Sensor Available
- Field Assembled Hood Ships with Economizer
- Economizer Ships Complete for Horizontal Duct Application
- Optional Remote Minimum Position Potentiometer (270 ohm) (Honeywell #S963B1136) is available from Prostock
- Field Installed Power Exhaust Available
- If connected to a Building Automation System (BAS), all economizer functions can be viewed on the (BAS) or 16 x 2 LCD screen
- If connected to thermostat, all economizer functions can be viewed on 16 x 2 LCD screen

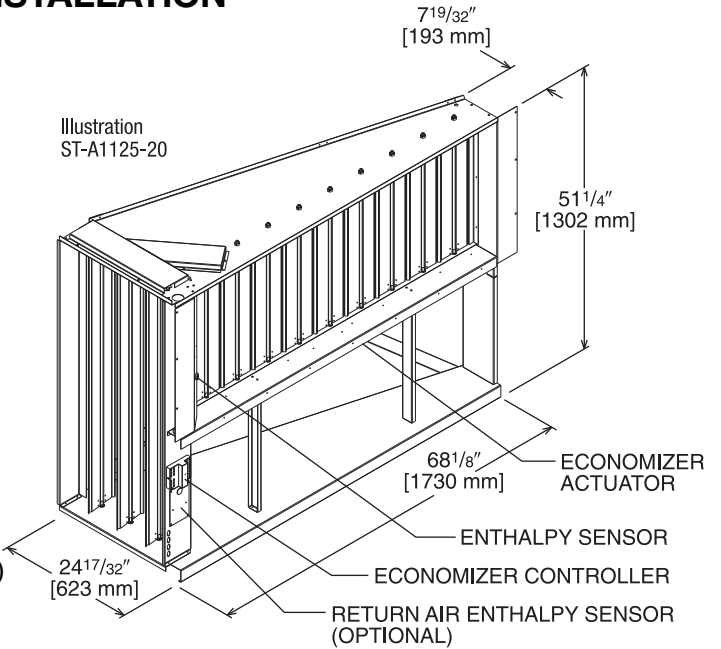

TOLERANCE ± .125

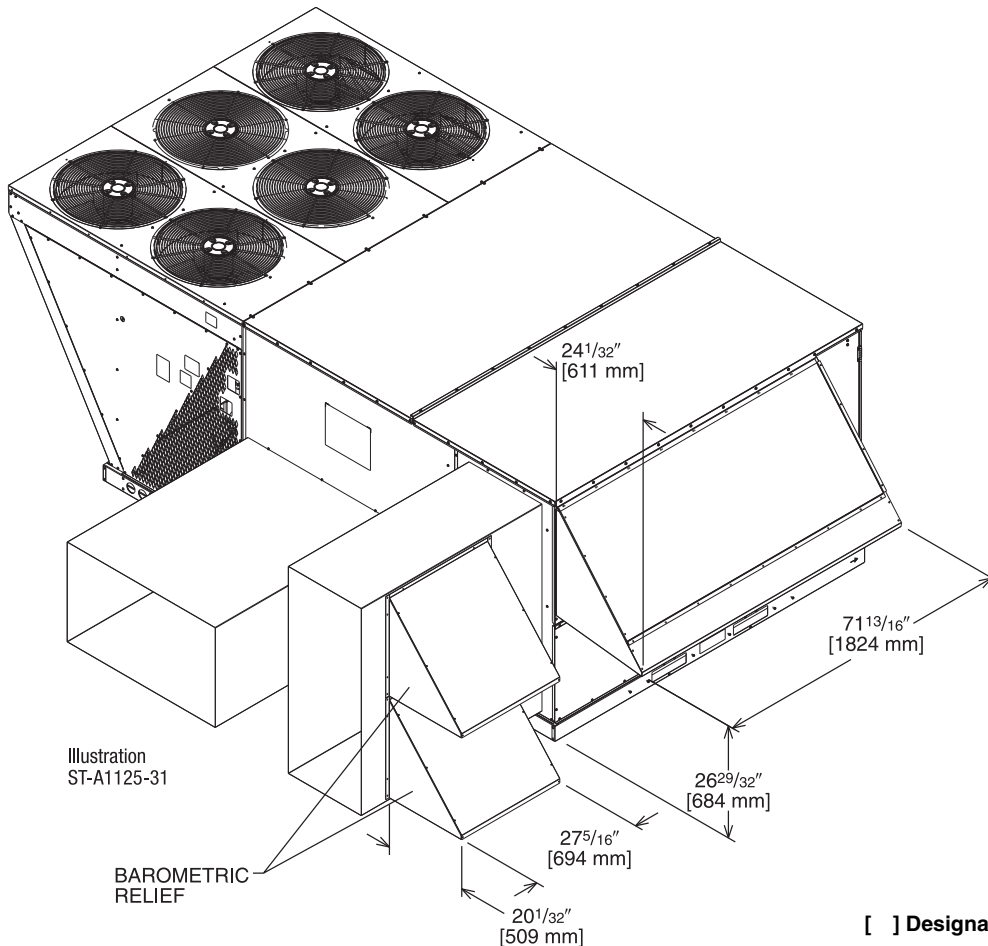

[] Designates Metric Conversions

POWER EXHAUST KIT FOR AXRD-PMCM3 & SMCM3 ECONOMIZERS

RXXR-BGF05 (C, D, or Y*)

*Voltage Code

VERTICAL AIRFLOW

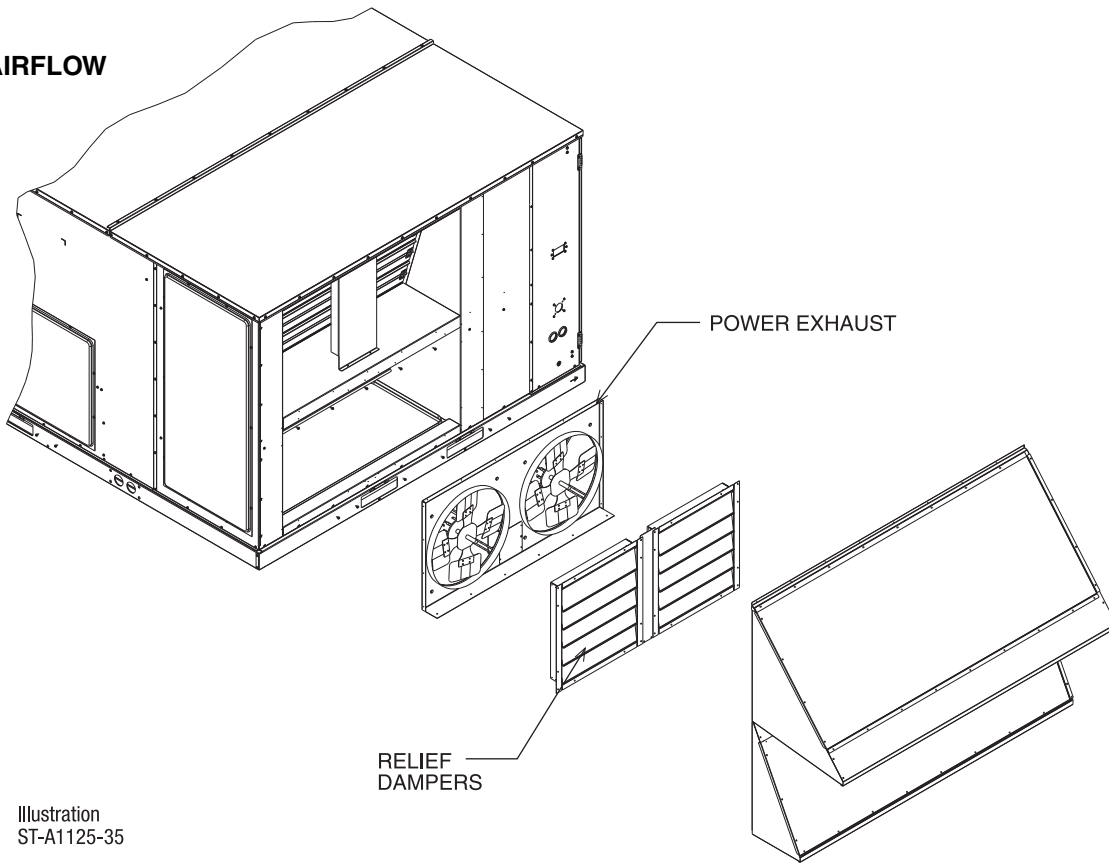

Illustration
ST-A1125-35

Model No.	No. of Fans	Volts	Phase	HP (ea.)	Low Speed		High Speed ①		FLA (ea.)	LRA (ea.)
					CFM [L/s] ②	RPM	CFM [L/s] ②	RPM		
RXXR-BGF05C	2	208-230	1	0.75	4100 [1935]	850	5200 [2454]	1050	5	4.97
RXXR-BGF05D	2	460	1	0.75	4100 [1935]	850	5200 [2454]	1050	2.2	3.4
RXXR-BGF05Y	2	575	1	0.75	4100 [1935]	850	5200 [2454]	1050	1.5	2.84

NOTES: ① Power exhaust is factory set on high speed motor tap.

② CFM is per fan at 0" w.c. external static pressure.

[] Designates Metric Conversions

FRESH AIR DAMPER

MOTORIZED DAMPER KIT

RXR-**AW03**

(Motor Kit for RXRF-KFA1)

RXR-**AW05**

(Modulating Motor Kit with position feedback for RXRF-KFA1)

- Features **Honeywell Controls**
- Gear Driven Direct Drive Actuator
- Fully Modulating (0-100%)
- Low Leakage Dampers
- Slip-In Design for Easy Installation
- Plug-In Polarized 12-pin and 4-pin Electrical Connections
- Pre-Configured—No Field Adjustments Necessary
- Addition of Dual Enthalpy Upgrade Kit allows limited economizer function
- CO₂ Sensor Input Available for Demand Control Ventilation (DCV)
- Optional Remote Minimum Position Potentiometer (270 ohm) (Honeywell #S963B1136) is available from Prostock.
- All fresh air damper functions can be viewed at the RTU-C unit controller display
- If connected to a Building Automation System (BAS), all fresh air damper functions can be viewed on the (BAS), on 16 x 2 LCD screen
- If connected to thermostat, all fresh air damper functions can be viewed on 16 x 2 LCD screen

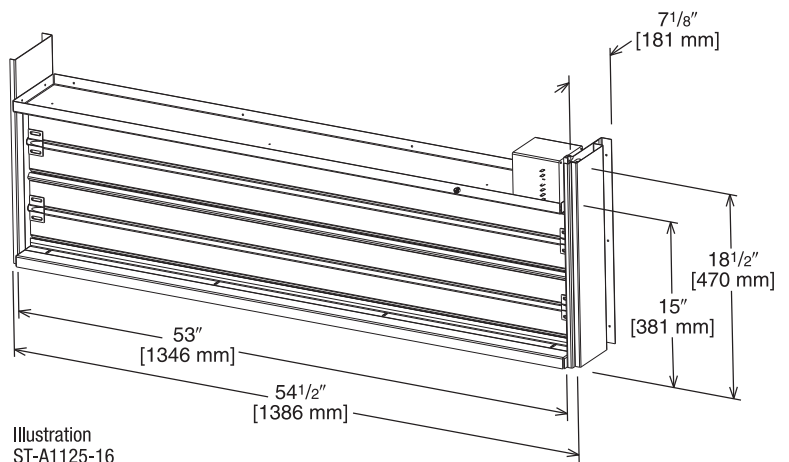

Illustration
ST-A1125-16

AXRF-KFA1 (Manual)

RXR-**AW03** (Motorized damper kit for manual fresh air damper)

RXR-**AW05** (Modulating damper kit with position feedback for RXRF-KFA1)

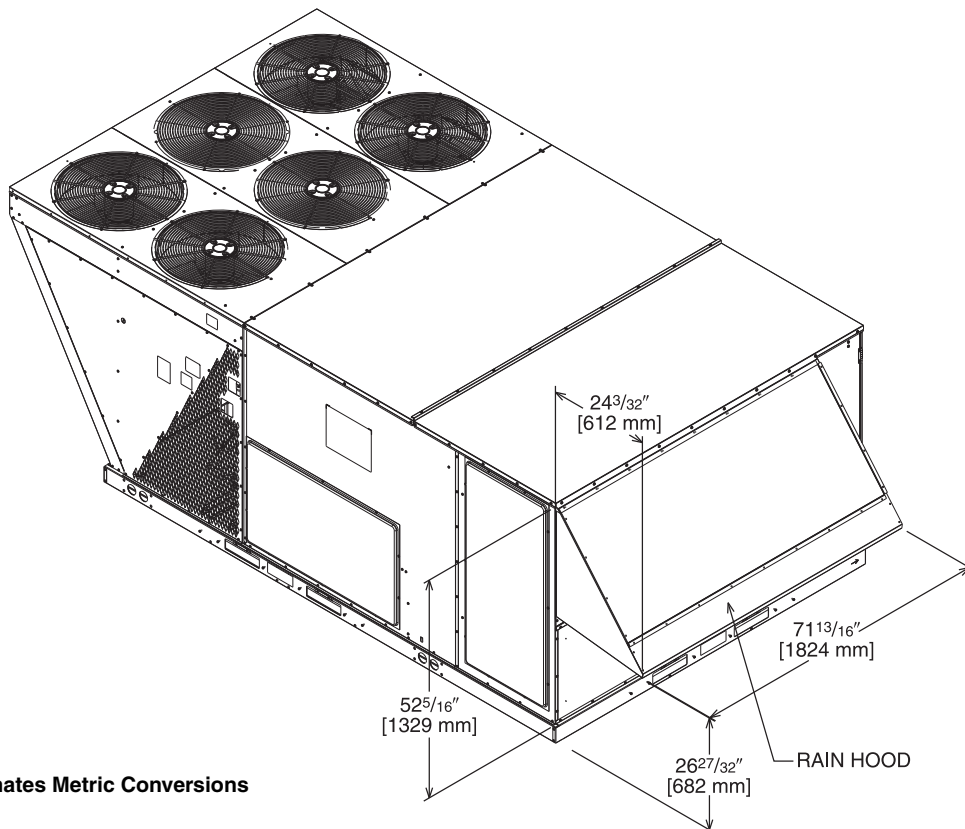

Illustration
ST-A1125-17

[] Designates Metric Conversions

ROOFCURBS (Full Perimeter)

- Ruud's new roofcurb designs can be utilized on 15, 17.5, 20 and 25 ton [52.8, 61.5, 70.3 and 87.9 kW] models.
- One available height (14" [356 mm]).
- Quick assembly corners for simple and fast assembly.
- 1" [25.4 mm] x 4" [102 mm] Nailers provided.
- Insulating panels not required because of insulated outdoor base pan.
- Sealing gasket (28" [711 mm]) provided with Roofcurb.
- Packaged for easy field assembly.

TYPICAL INSTALLATION

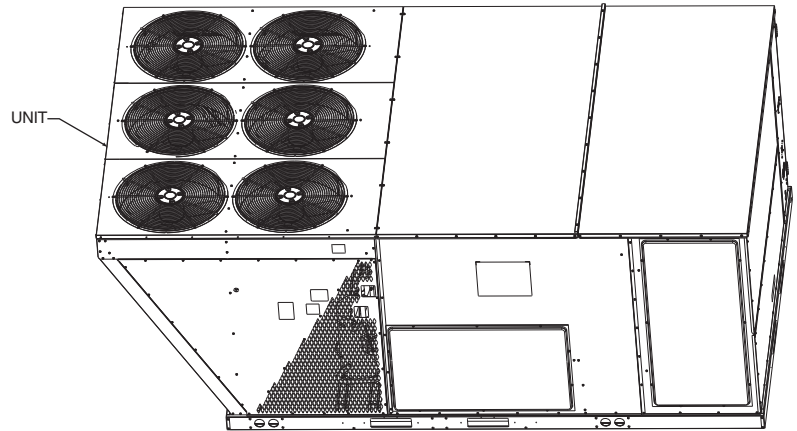

ROOFCURB ASSEMBLY

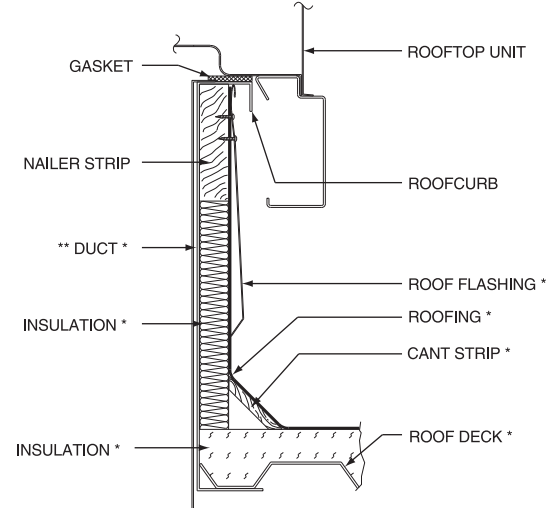
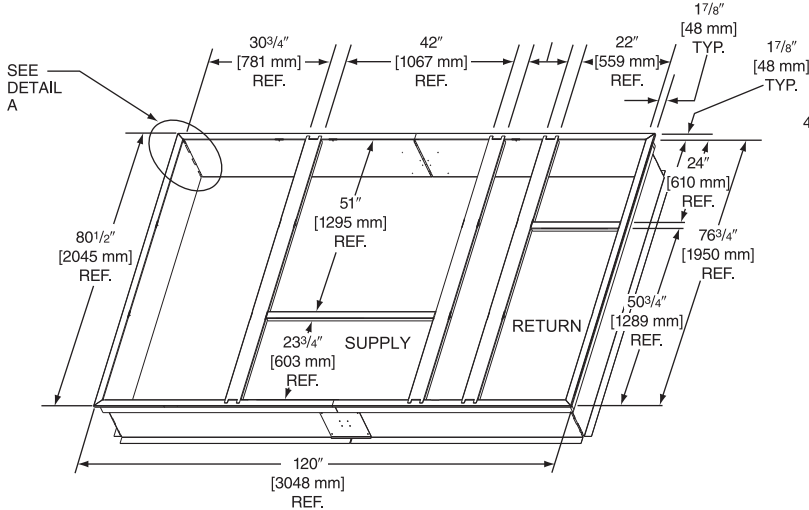
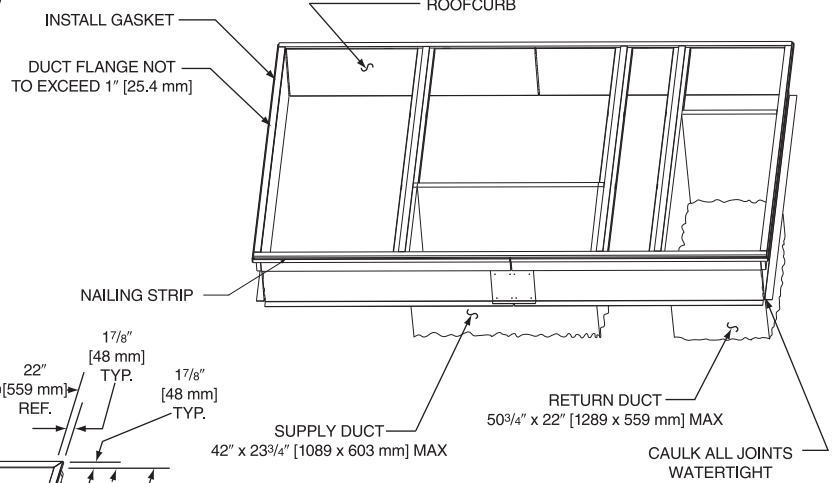
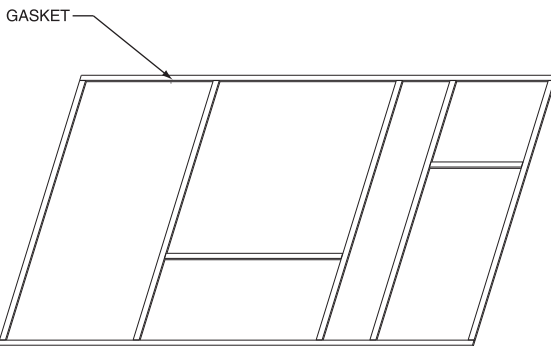
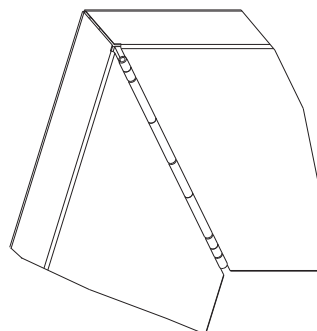

Illustration
ST-A1125-14



DETAIL A

[] Designates Metric Conversions

ROOFCURB ADAPTER

OLD MODELS

COMMERCIAL CABINET

(12.5, 15 & 20 TON)
([44, 52.8 & 70.3 kW])

(-)RCF, (-)RGF, (-)REF

OLD CURB MODEL

RXRK-E56

ROOFCURB ADAPTER

RXRK-CJCE56

NEW MODEL

(-)KNL

(15, 17.5, 20 & 25 TON)

([52.8, 61.5, 70.3 & 87.9 kW])

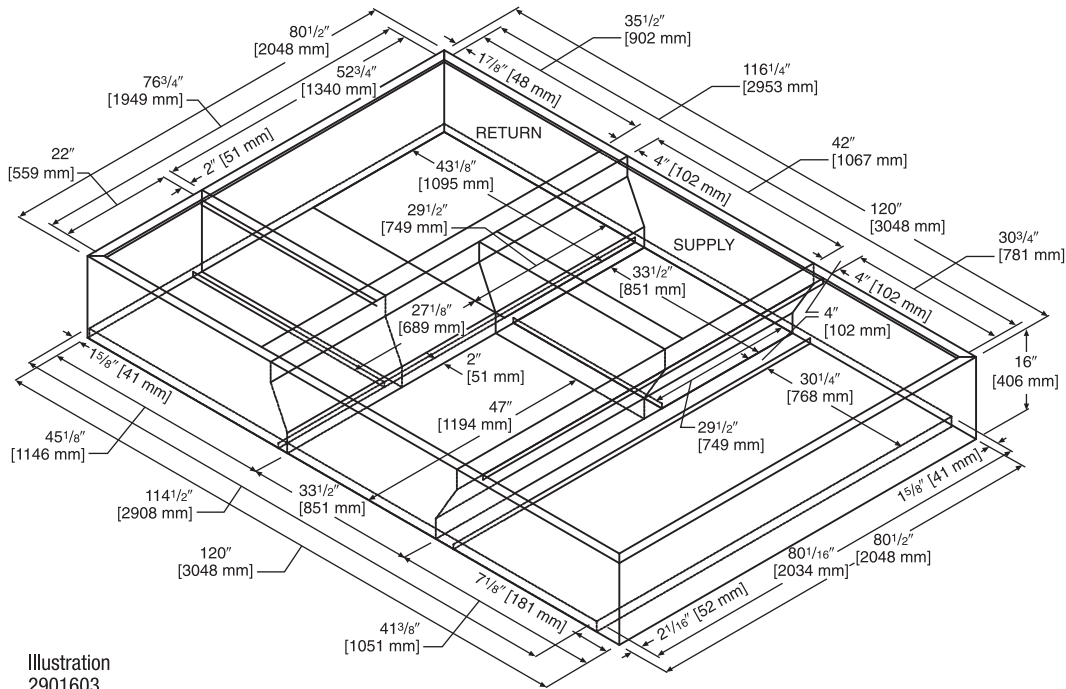

COMMERCIAL CABINET

(15, 20 & 25 TON)
([52.8, 70.3, 87.9 kW])

(-)KKB, (-)KMB, (-)KNB

RXKG-CAF14

RXRK-CJCF14

(-)KNL

(15, 17.5, 20 & 25 TON)

([52.8, 61.5, 70.3 & 87.9 kW])

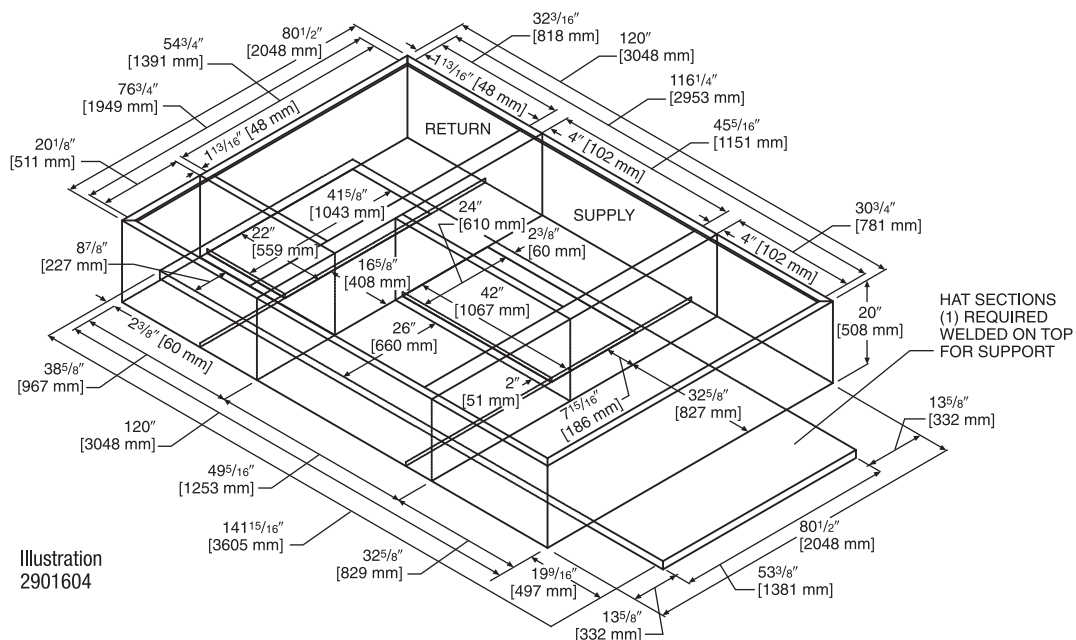

CONCENTRIC DIFFUSER APPLICATION

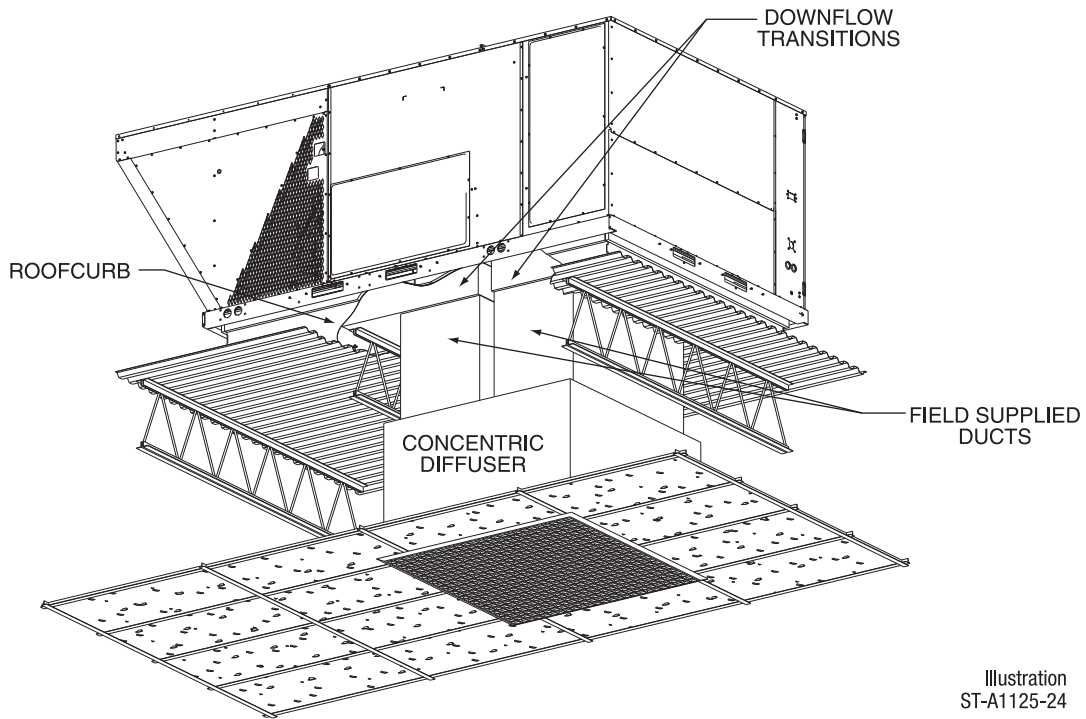

Illustration
ST-A1125-24

DOWNFLOW TRANSITION DRAWINGS

RXMC-CJ07 (15 Ton) [52.8 kW]

- Used with RXRN-AD80 and RXRN-AD81 Concentric Diffusers.

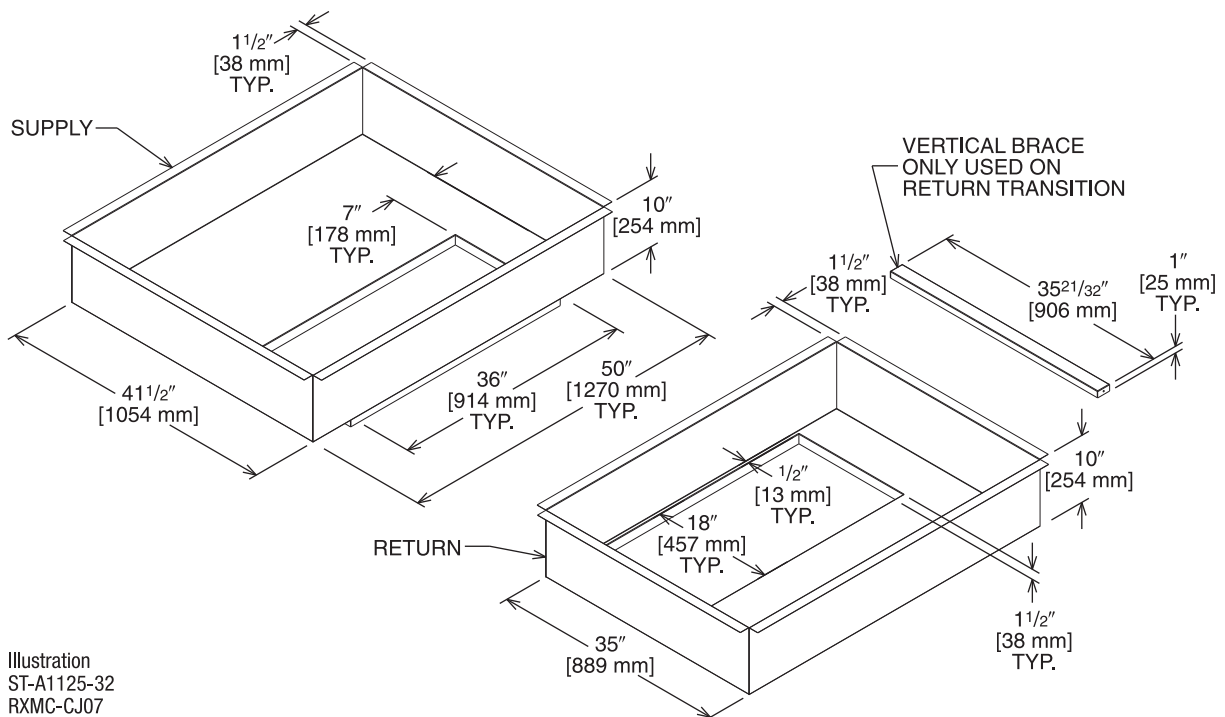

Illustration
ST-A1125-32
RXMC-CJ07

[] Designates Metric Conversions

DOWNFLOW TRANSITION DRAWINGS (Cont.)

RXMC-CK08 (20 Ton) [70.3 kW]

- Used with RXRN-AD86 Concentric Diffusers.

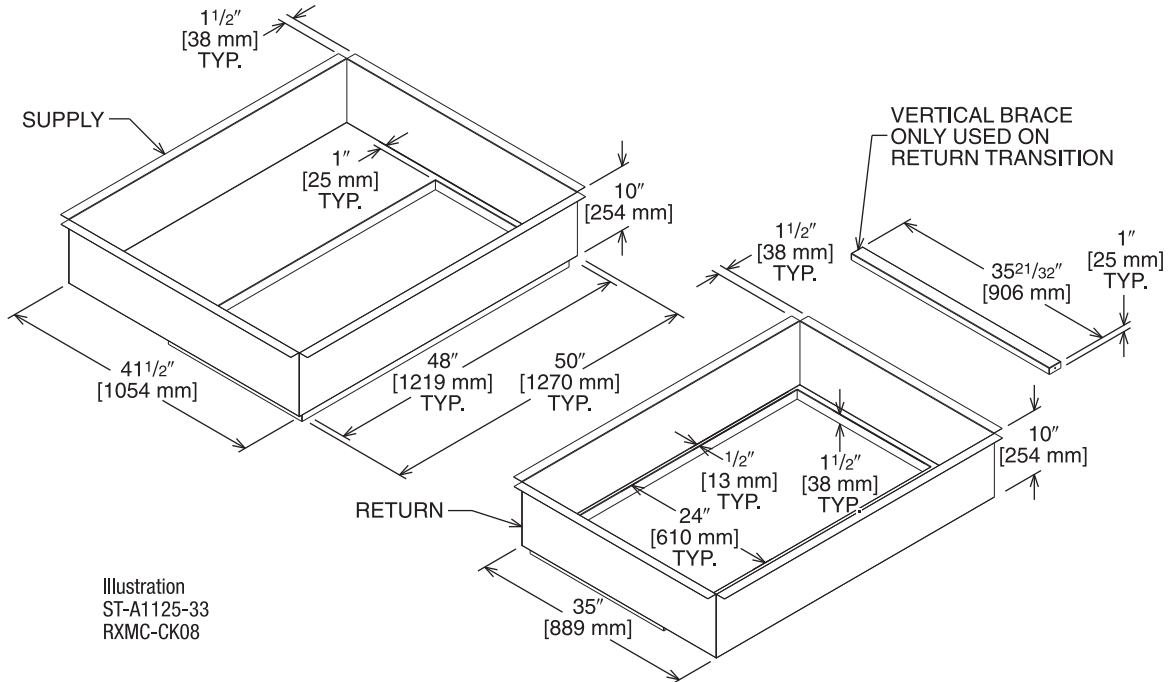

RXMC-CL09 (25 Ton) [87.9 kW]

- Used with RXRN-AD88 Concentric Diffusers.

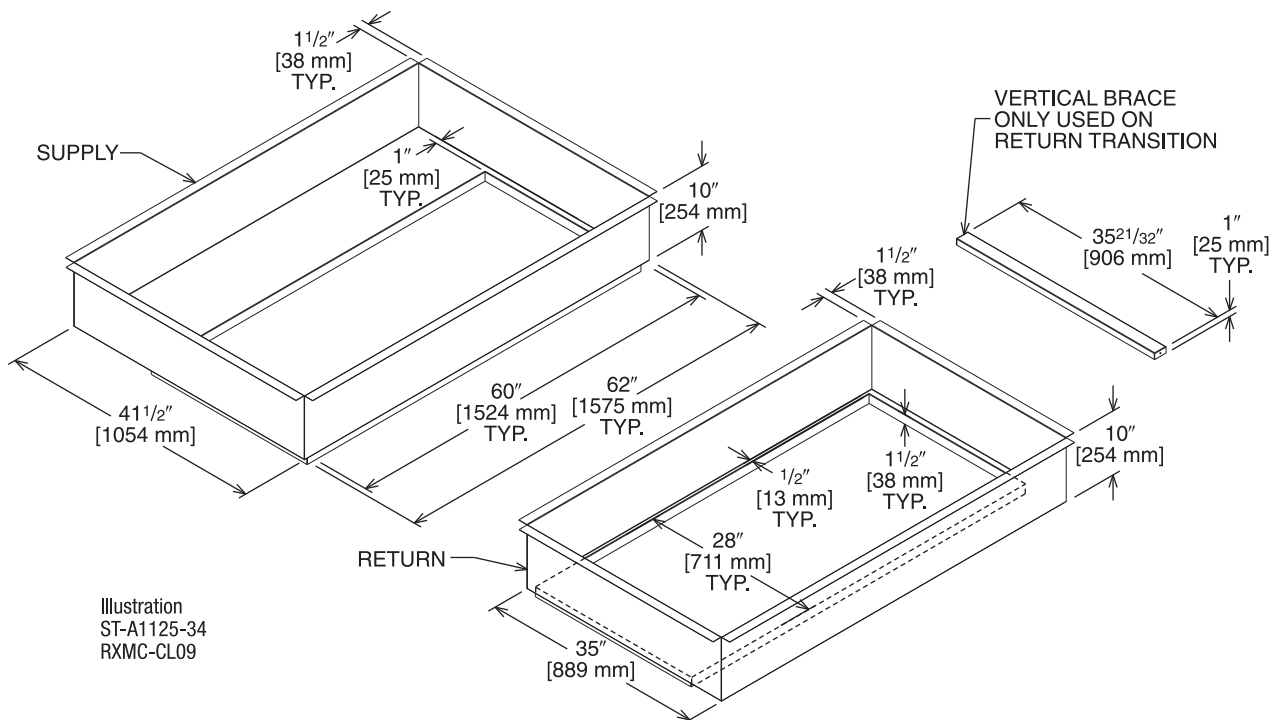

[] Designates Metric Conversions

**CONCENTRIC DIFFUSER
RXRN-AD80 SERIES
15 TON [52.8 kW] FLUSH**

- All aluminum diffuser with aluminum return air eggcrate.
- Built-in anti-sweat gasket.
- Molded fiberglass supports.
- Built-in hanging supports.
- Diffuser box constructed of sheetmetal insulated with 1" [25.4 mm] 1.5 lbs. [.7 kg] duct liner.

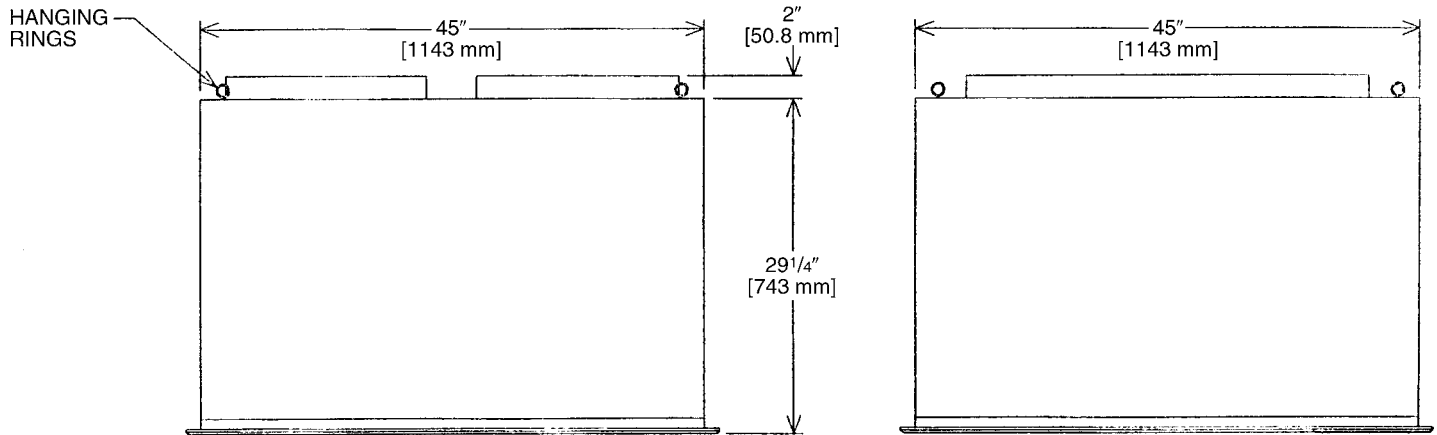
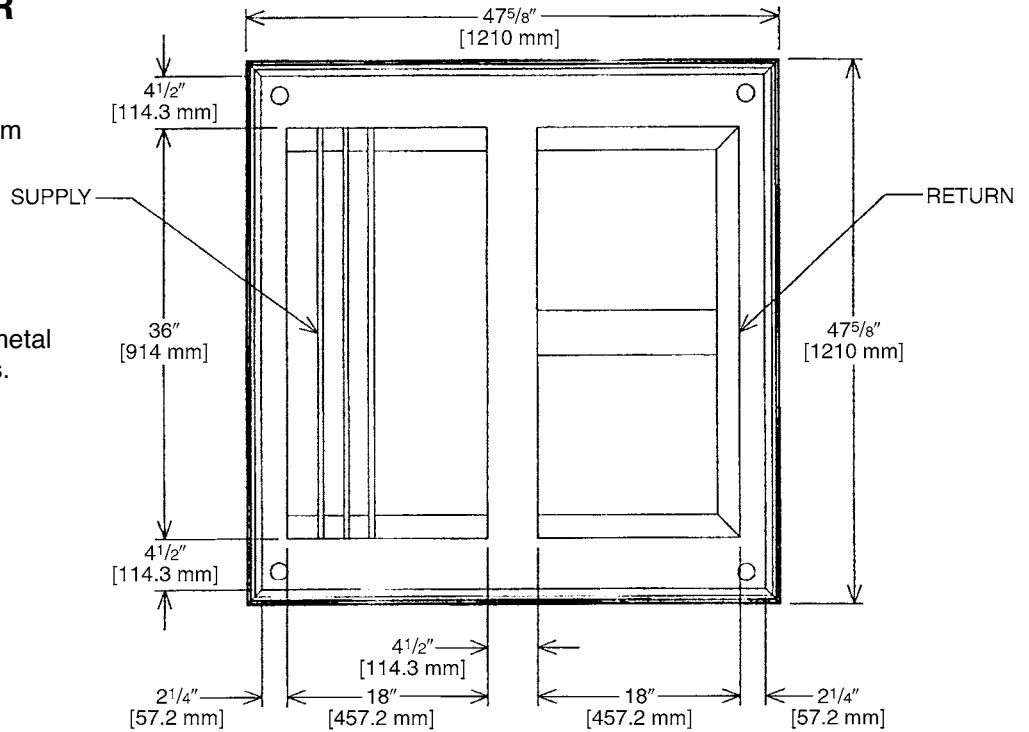

CONCENTRIC DIFFUSER SPECIFICATIONS

PART NUMBER	CFM [L/s]	STATIC PRESSURE	THROW FEET	NECK VELOCITY	JET VELOCITY
RXRN-AD80	5600 [2643]	0.36	28-37	1000	2082
	5800 [2737]	0.39	29-38	1036	2156
	6000 [2832]	0.42	40-50	1071	2230
	6200 [2926]	0.46	42-51	1107	2308
	6400 [3020]	0.50	43-52	1143	2379
	6600 [3115]	0.54	45-56	1179	2454

[] Designates Metric Conversions

CONCENTRIC DIFFUSER RXRN-AD81 SERIES 15 TON [52.8 kW] STEP DOWN

- All aluminum diffuser with aluminum return air eggcrate.
- Built-in anti-sweat gasket.
- Molded fiberglass supports.
- Built-in hanging supports.
- Diffuser box constructed of sheetmetal insulated with 1" [25.4 mm] 1.5 lbs. [.7 kg] duct liner.
- Double deflection diffuser with the blades secured by spring steel.

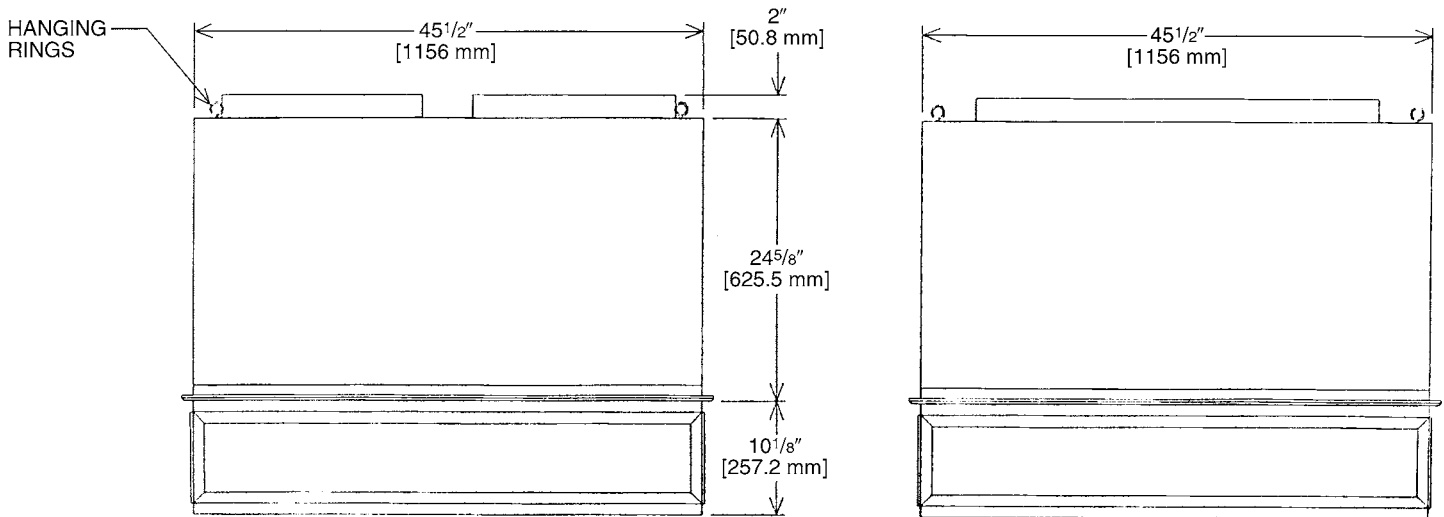
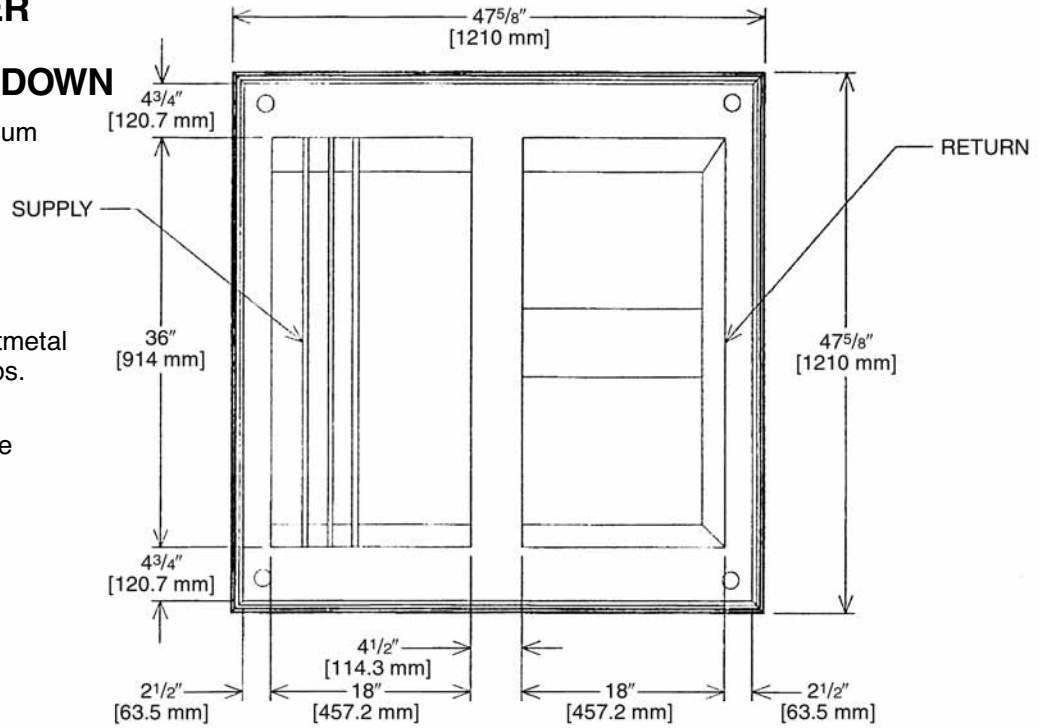

CONCENTRIC DIFFUSER SPECIFICATIONS

PART NUMBER	CFM [L/s]	STATIC PRESSURE	THROW FEET	NECK VELOCITY	JET VELOCITY
RXRN-AD81	5600 [2643]	0.36	39-49	920	920
	5800 [2737]	0.39	42-51	954	954
	6000 [2832]	0.42	44-54	1022	1022
	6200 [2926]	0.46	45-55	1056	1056
	6400 [3020]	0.50	46-55	1090	1090
	6600 [3115]	0.54	47-56	1124	1124

[] Designates Metric Conversions

CONCENTRIC DIFFUSER RXRN-AD86 SERIES 20 TON [70.3 kW] STEP DOWN

- All aluminum diffuser with aluminum return air eggcrate.
- Built-in anti-sweat gasket.
- Molded fiberglass supports.
- Built-in hanging supports.
- Diffuser box constructed of sheetmetal insulated with 1" [25.4 mm] 1.5 lbs. [.7 kg] duct liner.
- Double deflection diffuser with the blades secured by spring steel.

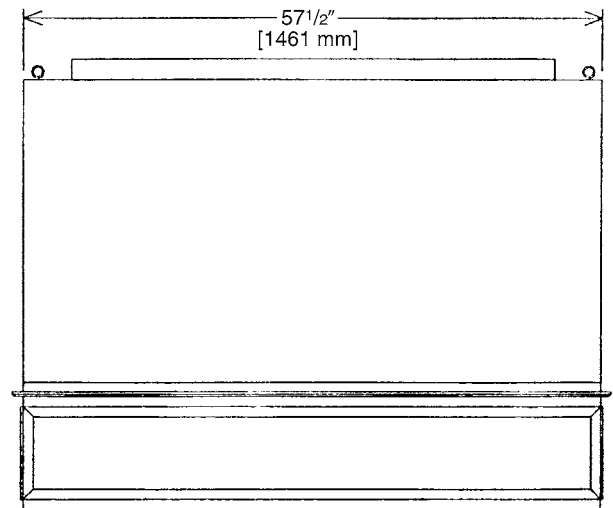
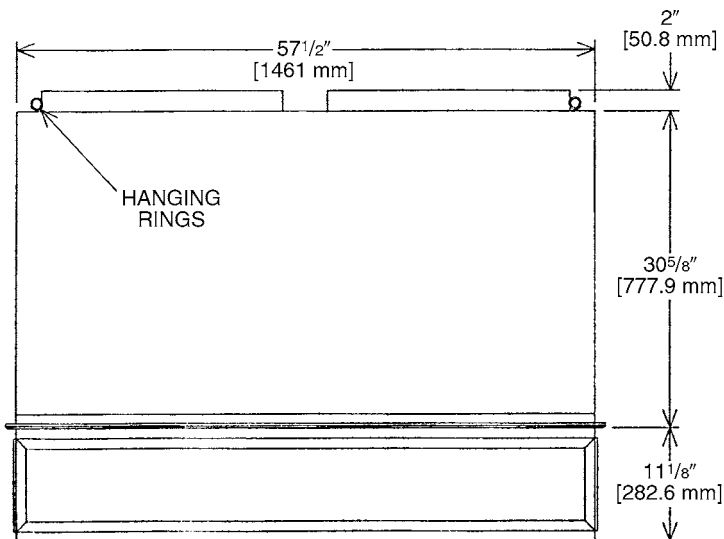
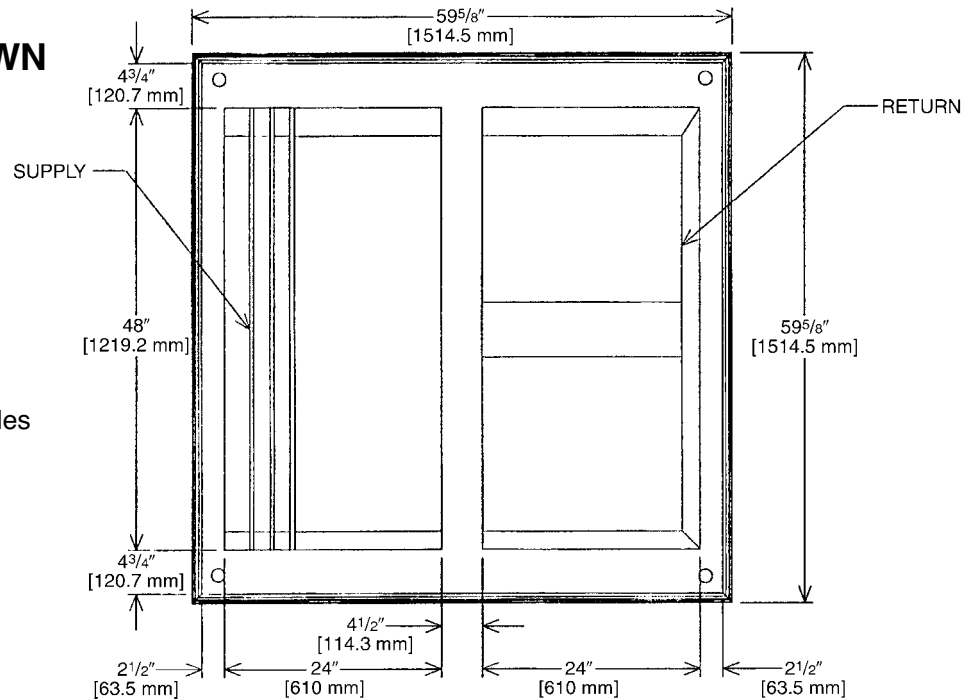

CONCENTRIC DIFFUSER SPECIFICATIONS

PART NUMBER	CFM [L/s]	STATIC PRESSURE	THROW FEET	NECK VELOCITY	JET VELOCITY
RXRN-AD86	7200 [3398]	0.39	33-38	827	827
	7400 [3492]	0.41	35-40	850	850
	7600 [3587]	0.43	36-41	873	873
	7800 [3681]	0.47	38-43	896	896
	8000 [3776]	0.50	39-44	918	918
	8200 [3870]	0.53	41-46	941	941
	8400 [3964]	0.56	43-49	964	964
	8600 [4059]	0.59	44-50	987	987
	8800 [4153]	0.63	47-55	1010	1010

[] Designates Metric Conversions

CONCENTRIC DIFFUSER RXRN-AD88 SERIES 25 TON [87.9 kW] STEP DOWN

- All aluminum diffuser with aluminum return air eggcrate.
- Built-in anti-sweat gasket.
- Molded fiberglass supports.
- Built-in hanging supports.
- Diffuser box constructed of sheetmetal insulated with 1" [25.4 mm] 1.5 lbs. [.7 kg] duct liner.
- Double deflection diffuser with the blades secured by spring steel.

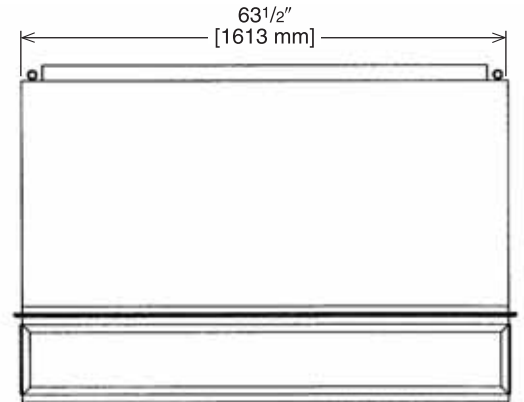
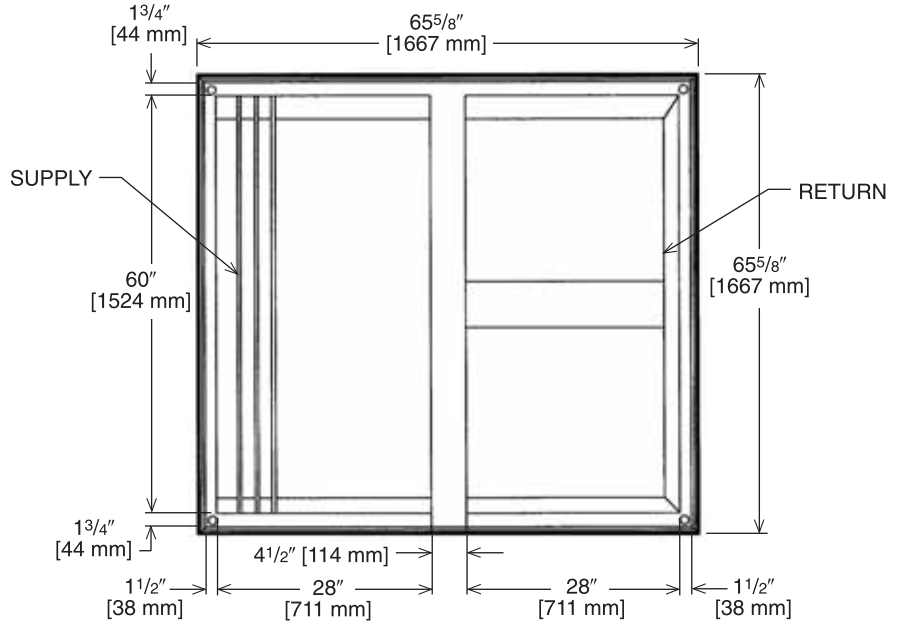

CONCENTRIC DIFFUSER SPECIFICATIONS

PART NUMBER	CFM [L/s]	STATIC PRESSURE	THROW FEET	NECK VELOCITY	JET VELOCITY
RXRN-AD88	10000 [4719]	0.51	46-54	907	907
	10500 [4955]	0.58	50-58	953	953
	11000 [5191]	0.65	53-61	998	998
	11500 [5427]	0.73	55-64	1043	1043
	12000 [5663]	0.82	58-67	1089	1089
	12500 [5898]	0.91	61-71	1134	1134
	13000 [6134]	1.00	64-74	1179	1179

[] Designates Metric Conversions

Guide Specifications RKNL-C180 thru C300

You may copy this document directly into your building specification. This specification is written to comply with the 2004 version of the "master format" as published by the Construction Specification Institute. www.csinet.org.

GAS HEAT PACKAGED ROOFTOP

HVAC Guide Specifications

Size Range: 15 to 25 Nominal Tons

Section Description

23 06 80 Schedules for Decentralized HVAC Equipment

23 06 80.13 Decentralized Unitary HVAC Equipment Schedule

23 06 80.13.A. Rooftop unit schedule

1. Schedule is per the project specification requirements.

23 07 16 HVAC Equipment Insulation

23 07 16.13 Decentralized, Rooftop Units:

1. Interior cabinet surfaces shall be insulated with a minimum 3/4-in. thick, minimum 1-1/2 lb density, flexible fiberglass insulation bonded with a phenolic binder, with aluminum foil facing on the air side.
2. Insulation and adhesive shall meet NFPA 90A requirements for flame spread and smoke generation.

23 09 13 Instrumentation and Control Devices for HVAC

23 09 13.23 Sensors and Transmitters

23 09 13.23.A. Thermostats

1. Thermostat must
 - a. have capability to energize 2 different stages of cooling, and 2 different stages of heating.
 - b. must include capability for occupancy scheduling.

23 09 23 Direct-digital Control system for HVAC

23 09 23.13 Decentralized, Rooftop Units:

23 09 23.13.A. RTU-C controller

1. Shall be ASHRAE 62-2001 compliant.
2. Shall accept 18-32VAC input power.
3. Shall have an operating temperature range from -40°F (-40°C) to 158°F (70°C), 10% - 95% RH (non-condensing).
4. Controller shall accept the following inputs: space temperature, setpoint adjustment, outdoor air temperature, indoor air quality, outdoor air enthalpy, fire shutdown, return air enthalpy, fan status, remote time clock/door switch.
5. Shall accept a CO₂ sensor in the conditioned space, and be Demand Control Ventilation (DCV) ready.
6. Shall provide the following outputs: Economizer, fan, cooling stage 1, cooling stage 2, heat stage 1, heat stage 2, heat stage 3/ exhaust/ occupied.
7. Unit shall provide surge protection for the controller through a circuit breaker.
8. Shall have a field installed communication card allowing the unit to be Internet capable, and communicate at a Baud rate of 19.2K or faster
9. Shall have an LED display independently showing the status of activity on the communication bus, and processor operation.
10. Shall have either a field installed BACnet® plug-in communication card which includes an EIA-485 protocol communication port, or a field installed LonWorks™ plug-in communications card.
11. Software upgrades will be accomplished by local download. Software upgrades through chip replacements are not allowed.
12. Shall be shock resistant in all planes to 5G peak, 11ms during operation, and 100G peak, 11ms during storage.
13. Shall be vibration resistant in all planes to 1.5G @ 20-300 Hz.
14. Shall support a bus length of 4000 ft max, 60 devices per 1000 ft section, and 1 RS-485 repeater per 1000 ft sections.

23 09 23.13.B. Open protocol, direct digital controller:

1. Shall be ASHRAE 62-2001 compliant.
2. Shall accept 18-30VAC, 50-60Hz, and consume 15VA or less power.
3. Shall have an operating temperature range from -40°F (-40°C) to 130°F (54°C), 10% - 90% RH (non-condensing).
4. Shall have either a field installed BACnet® plug-in communication card which includes an EIA-485 protocol communication port, or a field installed LonWorks™ plug-in communications card.
5. The BACnet® plug in communication card shall include built-in protocol for BACNET (MS/TP and PTP modes)
6. The LonWorks™ plug in communication card shall include the Echelon processor required for all Lon applications.
7. Shall allow access of up to 62 network variables (SNVT). Shall be compatible with all open controllers
8. Baud rate Controller shall be selectable through the EIA-485 protocol communication port.
9. Shall have an LED display independently showing the status of serial communication, running, errors, power, all digital outputs, and all analog inputs.
10. Shall accept the following inputs: space temperature, setpoint adjustment, outdoor air temperature, indoor air quality, outdoor air enthalpy, compressor lock-out, fire shutdown, enthalpy switch, and fan status/filter status/ humidity/ remote occupancy.

11. Shall provide the following outputs: economizer, fan, cooling stage 1, cooling stage 2, heat stage 1, heat stage 2, heat stage 3/ exhaust.
12. Software upgrades will be accomplished by either local or remote download. No software upgrades through chip replacements are allowed.

23 09 33 Electric and Electronic Control System for HVAC**23 09 33.13 Decentralized, Rooftop Units:****23 09 33.13.A. General:**

1. Shall be complete with self-contained low-voltage control circuit protected by a resettable circuit breaker on the 24-v transformer side. Transformer shall have 100VA capabilities.
2. Shall utilize color-coded wiring.
3. The heat exchanger shall be controlled by an integrated furnace controller (IFC) microprocessor. See heat exchanger section of this specification.
4. Shall include a central control terminal board to conveniently and safely provide connection points for vital control functions such as: smoke detectors, phase monitor, economizer, thermostat, DDC control options, loss of charge, freeze sensor, high pressure switches.
5. Unit shall include a minimum of one 10-pin screw terminal connection board for connection of control wiring.

23 09 33.23.B. Safeties:

1. Compressor over-temperature, over current.
2. Loss of charge switch.
 - a. Units with 2 compressors shall have different colored wires for the circuit 1 and circuit 2 low and high pressure switches.
 - b. Loss of charge switch shall use different color wire than the high pressure switch. The purpose is to assist the installer and service technician to correctly wire and or troubleshoot the rooftop unit.
 - c. Loss of charge switch shall have a different sized connector than the high pressure switch. They shall physically prevent the cross-wiring of the safety switches between the high and low pressure side of the system.
3. High-pressure switch.
 - a. Units with 2 compressors shall have different colored wires for the circuit 1 and circuit 2 low and high pressure switches.
 - b. High pressure switch shall use different color wire than the low pressure switch. The purpose is to assist the installer and service person to correctly wire and or troubleshoot the rooftop unit.
 - c. High pressure switch shall have a different sized connector than the loss of charge switch. They shall physically prevent the cross-wiring of the safety switches between the high and low pressure side of the system.
4. Freeze protection sensor, evaporator coil.
5. Automatic reset, motor thermal overload protector.
6. Heating section shall be provided with the following minimum protections.
 - a. High-temperature limit switches.
 - b. Induced draft motor pressure switch.
 - c. Flame rollout switch.
 - d. Flame proving controls.

23 09 93 Sequence of Operations for HVAC Controls**23 09 93.13 Decentralized, Rooftop Units:****23 40 13 Panel Air Filters****23 40 13.13 Decentralized, Rooftop Units:****23 40 13.13.A. Standard filter section shall**

1. Shall consist of factory-installed, low velocity, throwaway 2-in. thick fiberglass filters of commercially available sizes.
2. Unit shall use only one filter size. Multiple sizes are not acceptable.
3. Filter face velocity shall not exceed 365 fpm at nominal airflows.
4. Filters shall be accessible through an access panel as described in the unit cabinet section of the specification (23 81 19.13.H).

23 81 19 Self-Contained Air Conditioners**23 81 19.13 Small-Capacity Self-Contained Air Conditioners****23 81 19.13.A. General**

1. Outdoor, rooftop mounted, electrically controlled, heating and cooling unit utilizing a(n) hermetic scroll compressor(s) for cooling duty and gas combustion for heating duty.
2. Factory assembled, single-piece heating and cooling rooftop unit. Contained within the unit enclosure shall be all factory wiring, piping, controls, and special features required prior to field start-up.
3. Unit shall use environmentally safe, R-410A refrigerant.
4. Unit shall be installed in accordance with the manufacturer's instructions.
5. Unit must be selected and installed in compliance with local, state, and federal codes.

23 81 19.13.B. Quality Assurance

1. Unit meets ASHRAE 90.1-2004 minimum efficiency requirements.
2. 3 phase units are Energy Star qualified.
3. Unit shall be rated in accordance with AHRI Standards 210 and 360.
4. Unit shall be designed to conform to ASHRAE 15, 2001.
5. Unit shall be UL-tested and certified in accordance with ANSI Z21.47 Standards and UL-listed and certified under Canadian standards as a total package for safety requirements.
6. Insulation and adhesive shall meet NFPA 90A requirements for flame spread and smoke generation.
7. Unit casing shall be capable of withstanding 500-hour salt spray exposure per ASTM B117 (scribed specimen).
8. Unit casing shall be capable of withstanding Federal Test Method Standard No. 141 (Method 6061) 5000-hour salt spray.
9. Unit shall be designed in accordance with ISO 9001:2000, and shall be manufactured in a facility registered by ISO 9001:2000.
10. Roof curb shall be designed to conform to NRCA Standards.
11. Unit shall be subjected to a completely automated run test on the assembly line. The data for each unit will be stored at the factory, and must be available upon request.
12. Unit shall be designed in accordance with UL Standard 1995, including tested to withstand rain.
13. Unit shall be constructed to prevent intrusion of snow and tested to prevent snow intrusion into the control box up to 40 mph.

23 81 19.13.C. Delivery, Storage, and Handling

1. Unit shall be stored and handled per manufacturer's recommendations.
2. Lifted by crane requires either shipping top panel or spreader bars.
3. Unit shall only be stored or positioned in the upright position.

23 81 19.13.E. Project Conditions

1. As specified in the contract.

23 81 19.13.F. Operating Characteristics

1. Unit shall be capable of starting and running at 115°F (46°C) ambient outdoor temperature, meeting maximum load criteria of AHRI Standard 210/240 or 360 at $\pm 10\%$ voltage.
2. Compressor with standard controls shall be capable of operation down to 40°F (4°C), ambient outdoor temperatures. Accessory low ambient kit is necessary if mechanically cooling at ambient temperatures below 40°F (4°C).
3. Unit shall discharge supply air vertically or horizontally as shown on contract drawings.
4. Unit shall be factory configured for vertical supply & return configurations.
5. Unit shall be field convertible from vertical to horizontal configuration.

23 81 19.13.G. Electrical Requirements

1. Main power supply voltage, phase, and frequency must match those required by the manufacturer.

23 81 19.13.H. Unit Cabinet

1. Unit cabinet shall be constructed of galvanized steel, and shall be bonderized and coated with a baked enamel finish on all externally exposed surfaces.
2. Unit cabinet exterior paint shall be: film thickness, (dry) 0.003 inches minimum, gloss (per ASTM D523, 60°F / 16°C): 60, Hardness: H-2H Pencil hardness.
3. Evaporator fan compartment interior cabinet insulation shall conform to AHRI Standards 210 or 360 minimum exterior sweat criteria. Interior surfaces shall be insulated with a minimum 3/4-in. thick, 1 lb. density, flexible fiberglass insulation, aluminum foil-face coated on the air side.
4. Base of unit shall have locations for thru-the-base gas and electrical connections (factory installed or field installed), standard.
5. Base Rail
 - a. Unit shall have base rails on all sides.
 - b. Holes shall be provided in the base rails for rigging shackles to facilitate maneuvering and overhead rigging.

- c. Holes shall be provided in the base rail for moving the rooftop by fork truck.
- d. Base rail shall be a minimum of 14 gauge thickness.
- 6. Condensate pan and connections:
 - a. Shall be a sloped condensate drain pan made of a non-corrosive material.
 - b. Shall comply with ASHRAE Standard 62.
 - c. Shall use a 1" x 11-1/2 NPT drain connection through the side of the drain pan. Connection shall be made per manufacturer's recommendations.
- 7. Gas Connections:
 - a. All gas piping connecting to unit gas valve shall enter the unit cabinet at a single location on side of unit (horizontal plane).
 - b. Thru-the-base capability
 - i. Standard unit shall have a thru-the-base gas-line location using a raised, embossed portion of the unit basepan.
 - ii. No basepan penetration, other than those authorized by the manufacturer, is permitted.
- 8. Electrical Connections
 - a. All unit power wiring shall enter unit cabinet at a single, factory-prepared, knockout location.
 - b. Thru-the-base capability
 - i. Standard unit shall have a thru-the-base electrical location(s) using a raised, embossed portion of the unit basepan.
 - ii. No basepan penetration, other than those authorized by the manufacturer, is permitted.
- 9. Component access panels (standard)
 - a. Cabinet panels shall be easily removable for servicing.
 - b. Stainless steel metal hinges are standard on all doors.
 - c. Panels covering control box, indoor fan, indoor fan motor and gas components (where applicable), shall have 1/4 turn latches.

23 81 19.13.I. Gas Heat

- 1. General
 - a. Heat exchanger shall be an induced draft design. Positive pressure heat exchanger designs shall not be allowed.
 - b. Shall incorporate a direct-spark ignition system and redundant main gas valve.
 - c. Heat exchanger design shall allow combustion process condensate to gravity drain; maintenance to drain the gas heat exchanger shall not be required.
 - d. Gas supply pressure at the inlet to the rooftop unit gas valve must match that required by the manufacturer.
- 2. The heat exchanger shall be controlled by an integrated furnace controller (IFC) microprocessor.
 - a. IFC board shall notify users of fault using an LED (light-emitting diode).
- 3. Standard Heat Exchanger construction
 - a. Heat exchanger shall be of the tubular-section type constructed of a minimum of 20-gauge aluminum coated steel for corrosion resistance.
 - b. Burners shall be of the in-shot type constructed of aluminum-coated steel.
 - c. Burners shall incorporate orifices for rated heat output up to 2000 ft (610m) elevation. Additional accessory kits may be required for applications above 2000 ft (610m) elevation, depending on local gas supply conditions.
- 4. Optional Stainless Steel Heat Exchanger construction
 - a. Use energy saving, direct-spark ignition system.
 - b. Use a redundant main gas valve.
 - c. Burners shall be of the in-shot type constructed of aluminum-coated steel.
 - d. All gas piping shall enter the unit cabinet at a single location on side of unit (horizontal plane).
 - e. The optional stainless steel heat exchanger shall be of the tubular-section type, constructed of a minimum of 20-gauge type 409 stainless steel.
 - f. Type 409 stainless steel shall be used in heat exchanger tubes and vestibule plate.
 - g. Complete stainless steel heat exchanger allows for greater application flexibility.
- 5. Induced draft combustion motors and blowers
 - a. Shall be a direct-drive, single inlet, forward-curved centrifugal type.

- b. Shall be made from steel with a corrosion-resistant finish.
- c. Shall have permanently lubricated sealed bearings.
- d. Shall have inherent thermal overload protection.
- e. Shall have an automatic reset feature.

23 81 19.13.J. Coils**1. Standard Aluminum/Copper Coils:**

- a. Standard evaporator and condenser coils shall have aluminum lanced plate fins mechanically bonded to seamless internally grooved copper tubes with all joints brazed.
- b. Evaporator and condenser coils shall be leak tested to 150 psig, pressure tested to 550 psig, and qualified to UL 1995 burst test at 2,200 psi.

23 81 19.13.K. Refrigerant Components**1. Refrigerant circuit shall include the following control, safety, and maintenance features:**

- a. Thermal Expansion Valves (TXV) with orifice type distributor.
- b. Refrigerant filter drier.
- c. Service gauge connections on suction and discharge lines.
- d. Pressure gauge access through an access port in the front and rear panel of the unit.

2. Compressors

- a. Unit shall use one fully hermetic, scroll compressor for each independent refrigeration circuit.
- b. Compressor motors shall be cooled by refrigerant gas passing through motor windings.
- c. Compressors shall be internally protected from high discharge temperature conditions. Advanced Scroll Temperature Protection on 240-300 sizes.
- d. Compressors shall be protected from an over-temperature and over-ampereage conditions by an internal, motor overload device.
- e. Compressor shall be factory mounted on rubber grommets.
- f. Compressor motors shall have internal line break thermal and current overload protection.
- g. Crankcase heaters shall not be required for normal operating range.

23 81 19.13.L. Filter Section

- 1. Filters access is specified in the unit cabinet section of this specification.
- 2. Filters shall be held in place by filter tray, facilitating easy removal and installation.
- 3. Shall consist of factory-installed, low velocity, throw-away 2-in. thick fiberglass filters.
- 4. Filter face velocity shall not exceed 365 fpm at nominal airflows.
- 5. Filters shall be standard, commercially available sizes.
- 6. Only one size filter per unit is allowed.

23 81 19.13.M. Evaporator Fan and Motor**1. Evaporator fan motor:**

- a. Shall have permanently lubricated bearings.
- b. Shall have inherent automatic-reset thermal overload protection.
- c. Shall have a maximum continuous bhp rating for continuous duty operation; no safety factors above that rating shall be required.

2. Belt-driven Evaporator Fan:

- a. Belt drive shall include an adjustable-pitch motor pulley.
- b. Shall use sealed, permanently lubricated ball-bearing type.
- c. Blower fan shall be double-inlet type with forward-curved blades.
- d. Shall be constructed from steel with a corrosion resistant finish and dynamically balanced.

23 81 19.13.N. Condenser Fans and Motors**1. Condenser fan motors:**

- a. Shall be a totally enclosed motor.
- b. Shall use permanently lubricated bearings.
- c. Shall have inherent thermal overload protection with an automatic reset feature.
- d. Shall use a shaft-down design. Shaft-up designs including those with “rain-slinger devices” shall not be allowed.

2. Condenser Fans shall:

- a. Shall be a direct-driven propeller type fan
- b. Shall have aluminum blades riveted to corrosion-resistant steel spiders and shall be dynamically balanced.

23 81 19.13.O. Special Features

1. Integrated Economizers:
 - a. Integrated, gear-driven parallel modulating blade design type capable of simultaneous economizer and compressor operation.
 - b. Independent modules for vertical or horizontal return configurations shall be available. Vertical return modules shall be available as a factory installed option.
 - c. Damper blades shall be galvanized steel with metal gears. Plastic or composite blades on intake or return shall not be acceptable.
 - d. Shall include all hardware and controls to provide free cooling with outdoor air when temperature and/or humidity are below setpoints.
 - e. Shall be equipped with gear driven dampers for both the outdoor ventilation air and the return air for positive air stream control.
 - f. Shall be capable of introducing up to 100% outdoor air.
 - g. Shall be equipped with a barometric relief damper capable of relieving up to 100% return air. The barometric relief damper shall include seals, hardware and hoods to relieve building pressure. Damper shall gravity close upon unit shut down.
 - h. Shall be designed to close damper(s) during loss-of-power situations with spring return built into motor.
 - i. An outdoor single-enthalpy sensor shall be provided as standard. Outdoor air enthalpy set point shall be adjustable and shall range from the enthalpy equivalent of 63°F @ 50% rh to 73°F @ 50% rh. Additional sensor options shall be available as accessories.
 - j. The economizer controller shall also provide control of an accessory power exhaust unit function. Factory set at 70%, with a range of 0% to 100%.
 - k. The economizer shall maintain minimum airflow into the building during occupied period and provide design ventilation rate for full occupancy. A remote potentiometer may be used to override the damper set point.
 - l. Economizer controller shall accept a 2-10Vdc CO2 sensor input for IAQ/DCV control. In this mode, dampers shall modulate the outdoor-air damper to provide ventilation based on the sensor input.
 - m. Actuator shall be direct coupled to economizer gear. No linkage arms or control rods shall be acceptable.
 - n. Economizer controller shall provide indications when in free cooling mode, in the DCV mode, or the exhaust fan contact is closed.
2. Two-Position Damper
 - a. Damper shall be a Two-Position Damper. Damper travel shall be from the full closed position to the field adjustable %-open setpoint.
 - b. Damper shall include adjustable damper travel from 25% to 100% (full open).
 - c. Damper shall include single or dual blade, gear driven damper and actuator motor.
 - d. Actuator shall be direct coupled to economizer gear. No linkage arms or control rods shall be acceptable.
 - e. Damper will admit up to 100% outdoor air for applicable rooftop units.
 - f. Damper shall close upon indoor (evaporator) fan shutoff and/or loss of power.
 - g. The damper actuator shall plug into the rooftop unit's wiring harness plug. No hard wiring shall be required.
 - h. Outside air hood shall include aluminum water entrainment filter.
3. Manual damper
 - a. Manual damper package shall consist of damper, air inlet screen, and rain hood which can be preset to admit up to 50% outdoor air for year round ventilation.
4. Head Pressure Control Package
 - a. Controller shall control coil head pressure by condenser-fan cycling.
5. Liquid Propane (LP) Conversion Kit
 - a. Package shall contain all the necessary hardware and instructions to convert a standard natural gas unit for use with liquefied propane, up to 2000 ft (610m) elevation.
6. Unit-Mounted, Non-Fused Disconnect Switch:
 - a. Switch shall be factory-installed, internally mounted.
 - b. National Electric Code (NEC) and UL approved non-fused switch shall provide unit power shutoff.
 - c. Shall be accessible from outside the unit.
 - d. Shall provide local shutdown and lockout capability.

- e. Non-Powered convenience outlet.
 - f. Outlet shall be powered from a separate 115-120v power source.
 - g. A transformer shall not be included.
 - h. Outlet shall be field-installed and internally mounted with easily accessible 115-v female receptacle.
 - i. Outlet shall include 15 amp GFI receptacle.
 - j. Outlet shall be accessible from outside the unit.
7. Flue Discharge Deflector:
- a. Flue discharge deflector shall direct unit exhaust vertically instead of horizontally.
 - b. Deflector shall be defined as a “natural draft” device by the National Fuel and Gas (NFG) code.
8. Thru-the-Base Connectors:
- a. Kits shall provide connectors to permit gas and electrical connections to be brought to the unit through the unit basepan.
9. Propeller Power Exhaust:
- a. Power exhaust shall be used in conjunction with an integrated economizer.
 - b. Independent modules for vertical or horizontal return configurations shall be available.
 - c. Horizontal power exhaust is shall be mounted in return ductwork.
 - d. Power exhaust shall be controlled by economizer controller operation. Exhaust fans shall be energized when dampers open past the 0-100% adjustable setpoint on the economizer control.
10. Roof Curbs (Vertical):
- a. Full perimeter roof curb with exhaust capability providing separate airstreams for energy recovery from the exhaust air without supply air contamination.
 - b. Formed galvanized steel with wood nailer strip and shall be capable of supporting entire unit weight.
 - c. Permits installation and securing of ductwork to curb prior to mounting unit on the curb.
11. Universal Gas Conversion Kit:
- a. Package shall contain all the necessary hardware and instructions to convert a standard natural gas unit to operate from 2000-7000 ft (610 to 2134m) elevation with natural gas or from 0-7000 ft (90-2134m) elevation with liquefied propane.
12. Outdoor Air Enthalpy Sensor:
- a. The outdoor air enthalpy sensor shall be used to provide single enthalpy control. When used in conjunction with a return air enthalpy sensor, the unit will provide differential enthalpy control. The sensor allows the unit to determine if outside air is suitable for free cooling.
13. Return Air Enthalpy Sensor:
- a. The return air enthalpy sensor shall be used in conjunction with an outdoor air enthalpy sensor to provide differential enthalpy control.
14. Indoor Air Quality (CO₂) Sensor:
- a. Shall be able to provide demand ventilation indoor air quality (IAQ) control.
 - b. The IAQ sensor shall be available in wall mount with LED display. The set point shall have adjustment capability.
15. Smoke detectors:
- a. Shall be a Four-Wire Controller and Detector.
 - b. Shall be environmental compensated with differential sensing for reliable, stable, and drift-free sensitivity.
 - c. Shall use magnet-activated test/reset sensor switches.
 - d. Shall have tool-less connection terminal access.
 - e. Shall have a recessed momentary switch for testing and resetting the detector.
 - f. Controller shall include:
 - i. One set of normally open alarm initiation contacts for connection to an initiating device circuit on a fire alarm control panel
 - ii. Two Form-C auxiliary alarm relays for interface with rooftop unit or other equipment.
 - iii. One Form-C supervision (trouble) relay to control the operation of the Trouble LED on a remote test/reset station.
 - iv. Capable of direct connection to two individual detector modules.
 - v. Can be wired to up to 14 other duct smoke detectors for multiple fan shutdown applications.

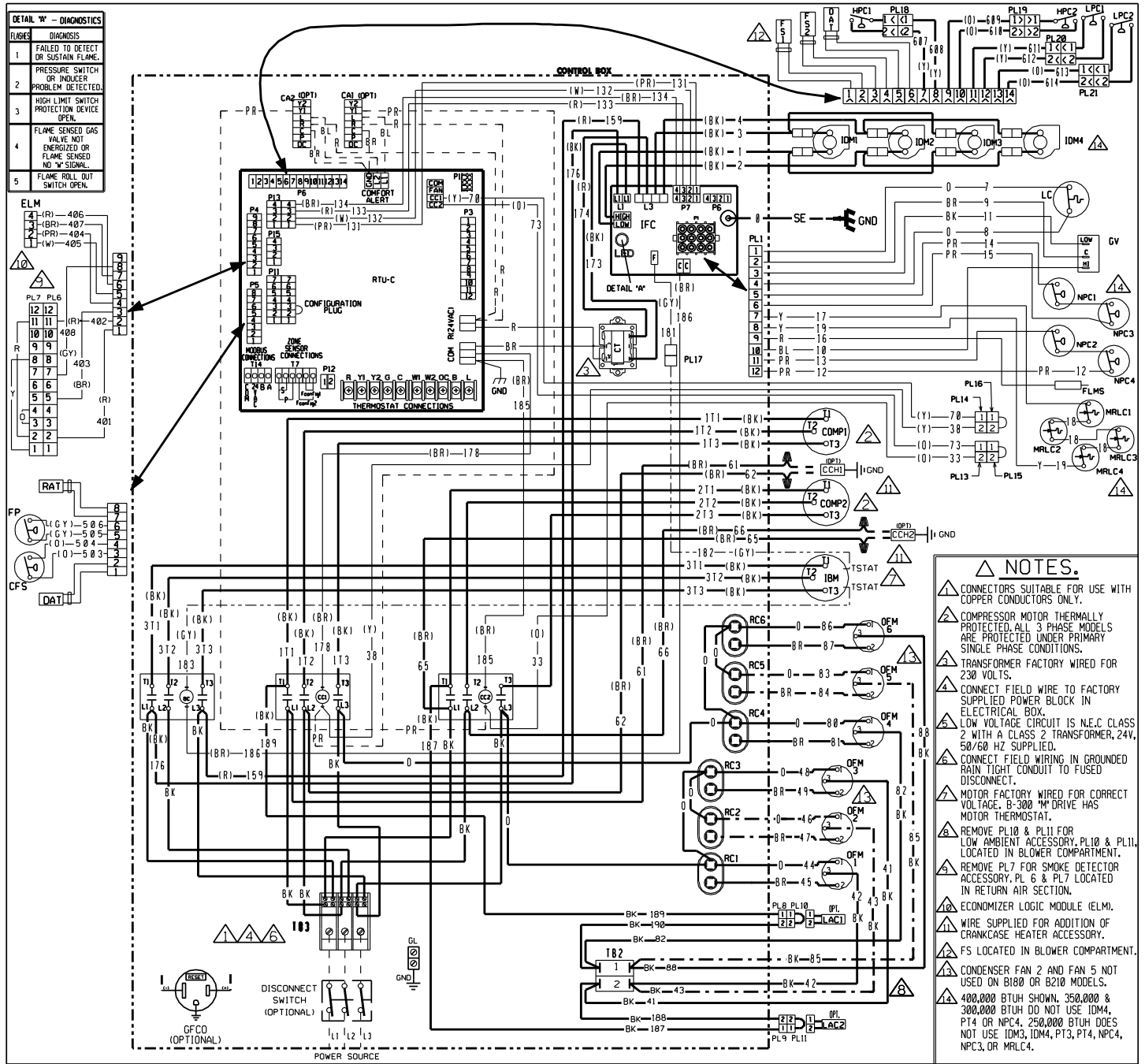

DETAIL 'W' - DIAGNOSTICS	
FLASKS	DIAGNOSIS
1	FAILED TO DETECT OR SUSTAIN FLAME.
2	PRESSURE SWITCH OR INDUCER PROBLEM DETECTED.
3	HIGH LIMIT SWITCH PROTECTION DEVICE OPEN.
4	FLAME SENSED GAS VALVE NOT ENERGIZED OR FLAME SENSED NO 'W' SIGNAL.
5	FLAME ROLL OUT SWITCH OPEN.

- NOTES.**
- ⚠ CONNECTORS SUITABLE FOR USE WITH COPPER CONDUCTORS ONLY.
 - ⚠ COMPRESSOR MOTOR THERMALLY PROTECTED. ALL 3 PHASE MODEL'S ARE PROTECTED UNDER PRIMARY SINGLE PHASE CONDITIONS.
 - ⚠ TRANSFORMER FACTORY WIRED FOR 230 VOLTS.
 - ⚠ CONNECT FIELD WIRE TO FACTORY SUPPLIED POWER BLOCK IN ELECTRICAL BOX.
 - ⚠ LOW VOLTAGE CIRCUIT IS N.E.C. CLASS 2 WITH A CLASS 2 TRANSFORMER, 24V, 50/60 HZ SUPPLIED.
 - ⚠ CONNECT FIELD WIRING IN GROUNDED RAIN TIGHT CONDUIT TO FUSED DISCONNECT.
 - ⚠ MOTOR FACTORY WIRED FOR CORRECT VOLTAGE. 0-300 'M' DRIVE HAS MOTOR THERMOSTAT.
 - ⚠ REMOVE PL10 & PL11 FOR LOW AMBIENT ACCESSORY. PL10 & PL11 LOCATED IN BLOWER COMPARTMENT.
 - ⚠ REMOVE PL7 FOR SMOKE DETECTOR ACCESSORY. PL 6 & PL7 LOCATED IN RETURN AIR SECTION.
 - ⚠ ECONOMIZER LOGIC MODULE (ELM).
 - ⚠ WIRE SUPPLIED FOR ADDITION OF CRANKCASE HEATER ACCESSORY.
 - ⚠ FS LOCATED IN BLOWER COMPARTMENT.
 - ⚠ CONDENSER FAN 2 AND FAN 5 NOT USED ON B180 OR B210 MODELS.
 - ⚠ 400,000 BTUH SHOWN. 350,000 & 300,000 BTUH DO NOT USE IDM4, PT4 OR NPC4. 250,000 BTUH DOES NOT USE IDM3, IDM4, PT3, PT4, NPC4, NPC3, OR MRLC4.

COMPONENT CODE		WIRING INFORMATION		WIRE COLOR CODE	
BC	BLOWER CONTACTOR	LINE VOLTAGE	---	BK	BLACK
CA	COMFORT ALERT MODULE	-FACTORY STANDARD	---	BR	BROWN
CC	COMPRESSOR CONTACTOR	-FACTORY OPTION	---	BL	BLUE
CCH	CRANKCASE HEATER	-FIELD INSTALLED	---	G	GREEN
CFS	CLOGGED FILTER SWITCH	LOW VOLTAGE	---	GY	GRAY
COMP	COMPRESSOR	-FACTORY STANDARD	---	O	ORANGE
CT	CONTROL TRANSFORMER	-FACTORY OPTION	---	PR	PURPLE
DAT	DISCHARGE AIR SENSOR	-FIELD INSTALLED	---	R	RED
DISC	DISCONNECT SWITCH	REPLACEMENT WIRE	---	W	WHITE
FLMS	FLAME SENSOR	-MUST BE THE SAME SIZE AND TYPE OF INSULATION AS ORIGINAL (105° C MIN.)	---	Y	YELLOW
FP	FAN PROVING	WARNING	---		
FS	FREEZE SENSOR	-CABINET MUST BE PERMANENTLY GROUNDED AND CONFORM TO I.E.C., N.E.C., C.E.C., AND LOCAL CODES AS APPLICABLE.	---		
GFCD	GROUND FAULT CONVENIENCE OUTLET				
GL	GROUND LUG				
GND	GROUND				
GV	GAS VALVE				
HPC	HIGH PRESSURE CONTROL				
IBM	INDOOR BLOWER MOTOR BELT DRIVE				
IDM	INDUCED DRAFT MOTOR				
IFC	INTEGRATED FURNACE CONTROL				
LAC	LOW AMBIENT COOLING CONTROL				
LC	LIMIT CONTROL				
LPC	LOW PRESSURE CONTROL				
MRLC	MANUAL RESET LIMIT CONTROL				
NPC	NEGATIVE PRESSURE CONTROL				
OAT	OUTSIDE AIR SENSOR				
OFM	OUTDOOR FAN MOTOR				
PL	PLUG				
PT	POWER TRANSFORMER				
RAT	RETURN AIR SENSOR				
RC	RUN CAPACITOR				
RTU-C	ROOFTOP UNIT CONTROL				
SE	SPARK ELECTRODE				
TB	TERMINAL BLOCK				
W	WIRE NUT				

WIRING DIAGRAM
RKNL-C180/210/240/300
 208-230/460V 3 PH, 60 HZ.
 ROOFTOP W/RTU-C

DR. BY MGR APP. BY DATE 4-13-09 DWG. NO. 90-103079-02 REV 01

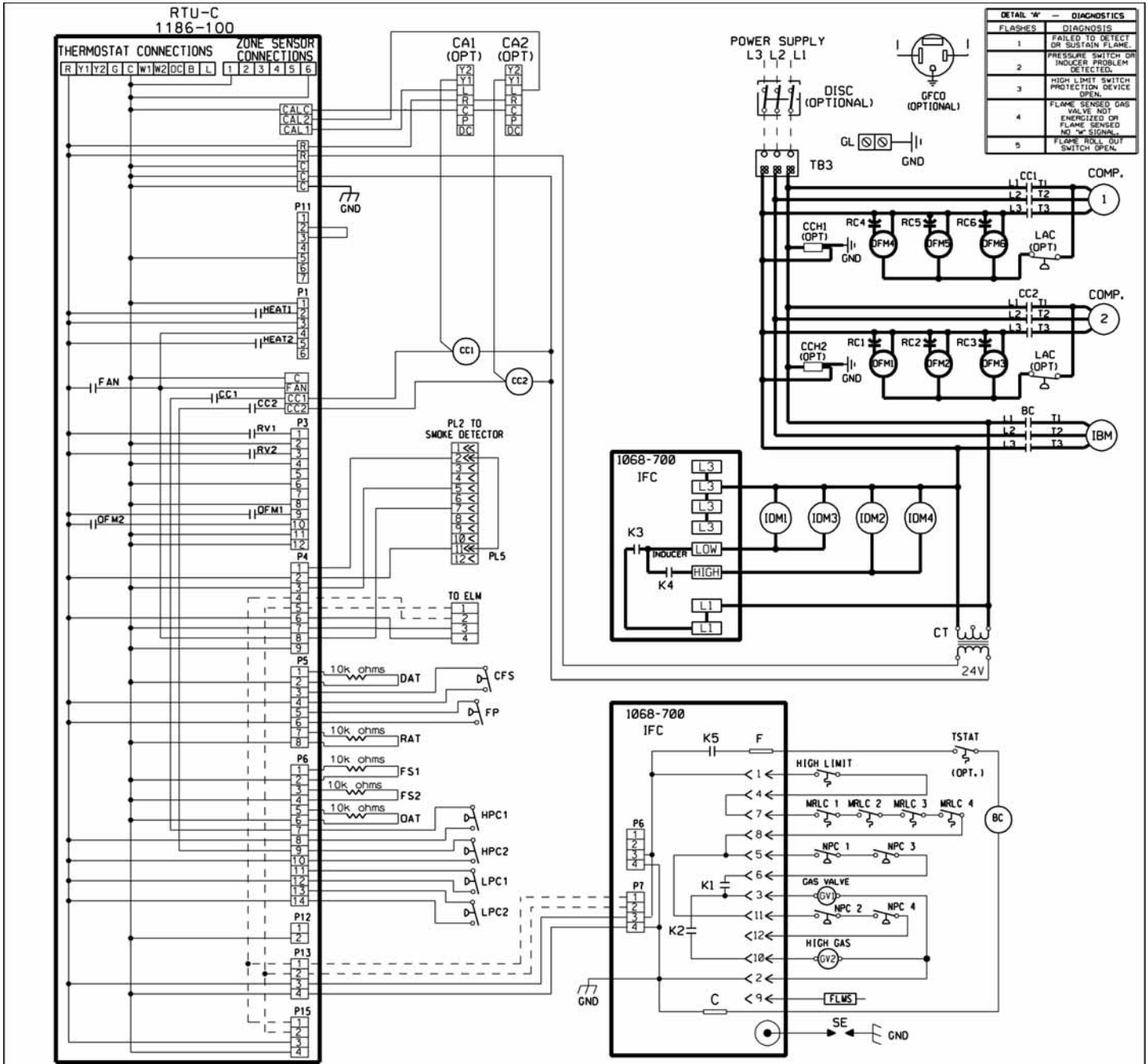

DETAIL 'W' - DIAGNOSTICS	
FLASHES	DIAGNOSIS
1	FAILED TO DETECT OR SUSTAIN FLAME.
2	PRESSURE SWITCH OR INDUCER PROBLEM DETECTED.
3	HIGH LIMIT SWITCH PROTECTION DEVICE OPEN.
4	FLAME SENSED GAS VALVE NOT ENERGIZED OR FLAME SENSED NO "W" SIGNAL.
5	FLAME ROLL-OUT SWITCH OPEN.

COMPONENT CODE		WIRING INFORMATION	WIRE COLOR CODE
BC	BLOWER CONTACTOR	LINE VOLTAGE	BK__BLACK
CA	COMFORT ALERT MODULE	-FACTORY STANDARD	BR__BROWN
CC	COMPRESSOR CONTACTOR	-FACTORY OPTION	BL__BLUE
CCH	CRANKCASE HEATER	-FIELD INSTALLED	G__GREEN
CFS	CLOGGED FILTER SWITCH	LOW VOLTAGE	GY__GRAY
COMP	COMPRESSOR	-FACTORY STANDARD	O__ORANGE
CT	CONTROL TRANSFORMER	-FACTORY OPTION	PR__PURPLE
DISC	DISCONNECT SWITCH	-FIELD INSTALLED	R__RED
FLMS	FLAME SENSOR	REPLACEMENT WIRE	W__WHITE
FP	FAN PROVING	-MUST BE THE SAME SIZE AND TYPE OF INSULATION AS ORIGINAL (105° C MIN.)	Y__YELLOW
FS	FREEZE SENSOR	WARNING	
GFCO	GROUND FAULT CONVENIENCE OUTLET	-CABINET MUST BE PERMANENTLY GROUNDED AND CONFORM TO I.E.C., N.E.C., C.E.C., AND LOCAL CODES AS APPLICABLE.	
GL	GROUND LUG		
GND	GROUND		
GV	GAS VALVE		
HPC	HIGH PRESSURE CONTROL		
IBM	INDOOR BLOWER MOTOR BELT DRIVE		
IDM	INDUCED DRAFT MOTOR		
IFC	INTEGRATED FURNACE CONTROL		
LAC	LOW AMBIENT COOLING CONTROL		
LC	LIMIT CONTROL		
LPC	LOW PRESSURE CONTROL		
MAS	MIX AIR SENSOR		
MRLC	MANUAL RESET LIMIT CONTROL		
NPC	NEGATIVE PRESSURE CONTROL		
DAT	OUTSIDE AIR SENSOR		
OFM	OUTDOOR FAN MOTOR		
PL	PLUG		
RAT	RETURN AIR SENSOR		
RC	RUN CAPACITOR		
SCC	SPACE COMFORT CONTROL		
SE	SPARK ELECTRODE		
TB	TERMINAL BLOCK		
WIRE NUT	WIRE NUT		

90-103263-02
REV 00

DR. BY MGR APP. BY DATE 7-16-09 DWG. NO. 90-103263-02 REV 00

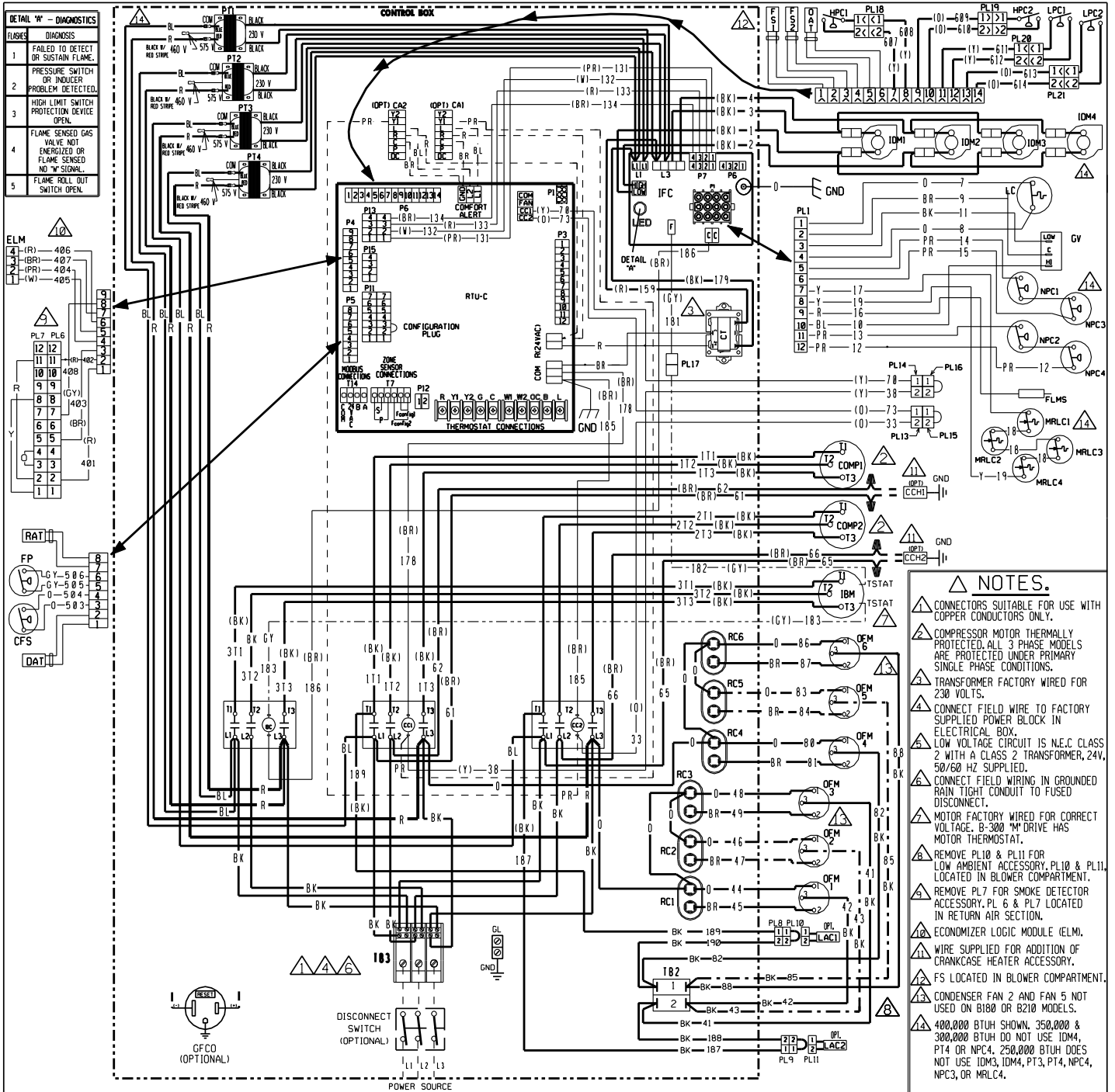

FLUKE	DIAGNOSIS
1	FAILED TO DETECT OR SUSTAIN FLAME.
2	PRESSURE SWITCH OR INDUCER PROBLEM DETECTED.
3	HIGH LIMIT SWITCH PROTECTION DEVICE OPEN.
4	FLAME SENSED GAS VALVE NOT ENERGIZED OR FLAME SENSED NO "M" SIGNAL.
5	FLAME ROLL OUT SWITCH OPEN.

- NOTES.**
- ⚠ CONNECTORS SUITABLE FOR USE WITH COPPER CONDUCTORS ONLY.
 - ⚠ COMPRESSOR MOTOR THERMALLY PROTECTED. ALL 3 PHASE MODELS ARE PROTECTED UNDER PRIMARY SINGLE PHASE CONDITIONS.
 - ⚠ TRANSFORMER FACTORY WIRE FOR 230 VOLTS.
 - ⚠ CONNECT FIELD WIRE TO FACTORY SUPPLIED POWER BLOCK IN ELECTRICAL BOX.
 - ⚠ LOW VOLTAGE CIRCUIT IS N.E.C. CLASS 2 WITH A CLASS 2 TRANSFORMER, 24V, 50/60 HZ SUPPLIED.
 - ⚠ CONNECT FIELD WIRING IN GROUNDED RAIN TIGHT CONDUIT TO FUSED DISCONNECT.
 - ⚠ MOTOR FACTORY WIRE FOR CORRECT VOLTAGE. B-300 "M" DRIVE HAS MOTOR THERMOSTAT.
 - ⚠ REMOVE PL10 & PL11 FOR LOW AMBIENT ACCESSORY. PL10 & PL11 LOCATED IN BLOWER COMPARTMENT.
 - ⚠ REMOVE PL7 FOR SMOKE DETECTOR ACCESSORY. PL 6 & PL7 LOCATED IN RETURN AIR SECTION.
 - ⚠ ECONOMIZER LOGIC MODULE (ELM). WIRE SUPPLIED FOR ADDITION OF CRANKCASE HEATER ACCESSORY.
 - ⚠ FS LOCATED IN BLOWER COMPARTMENT.
 - ⚠ CONDENSER FAN 2 AND FAN 5 NOT USED ON B180 OR B210 MODELS.
 - ⚠ 400,000 BTUH SHOWN. 350,000 & 300,000 BTUH DO NOT USE IDM4, PT4 OR NPC4. 250,000 BTUH DOES NOT USE IDM3, IDM4, PT3, PT4, NPC4, NPC3, OR MRLC4.

COMPONENT CODE	
BC	BLOWER CONTACTOR
CA	COMFORT ALERT MODULE
CC	COMPRESSOR CONTACTOR
CCH	CRANKCASE HEATER
CFS	CLOGGED FILTER SWITCH
COMP	COMPRESSOR
CT	CONTROL TRANSFORMER
DAT	DISCHARGE AIR SENSOR
DISC	DISCONNECT SWITCH
FLMS	FLAME SENSOR
FP	FAN PROVING
FS	FREEZE SENSOR
GFCD	GROUND FAULT CONVENIENCE OUTLET
GL	GROUND LUG
GND	GROUND
GV	GAS VALVE
HPC	HIGH PRESSURE CONTROL
IBM	INDOOR BLOWER MOTOR BELT DRIVE
IDM	INDUCED DRAFT MOTOR
IFC	INTEGRATED FURNACE CONTROL
LAC	LOW AMBIENT COOLING CONTROL
LC	LIMIT CONTROL
LPC	LOW PRESSURE CONTROL
MRLC	MANUAL RESET LIMIT CONTROL
NPC	NEGATIVE PRESSURE CONTROL
OAT	OUTSIDE AIR SENSOR
OFM	OUTDOOR FAN MOTOR
PL	PLUG
PT	POWER TRANSFORMER
RAT	RETURN AIR SENSOR
RC	RUN CAPACITOR
RTU-C	ROOFTOP UNIT CONTROL
SE	SPARK ELECTRODE
TB	TERMINAL BLOCK
WIRE NUT	WIRE NUT

WIRING INFORMATION

LINE VOLTAGE
 -FACTORY STANDARD
 -FACTORY OPTION
 -FIELD INSTALLED

LOW VOLTAGE
 -FACTORY STANDARD
 -FACTORY OPTION
 -FIELD INSTALLED

REPLACEMENT WIRE
 -MUST BE THE SAME SIZE AND TYPE OF INSULATION AS ORIGINAL (105° C MIN.)

WARNING
 -CABINET MUST BE PERMANENTLY GROUNDED AND CONFORM TO I.E.C., N.E.C. C.E.C., AND LOCAL CODES AS APPLICABLE.

WIRE COLOR CODE			
BK	BLACK	O	ORANGE
BR	BROWN	PR	PURPLE
BL	BLUE	R	RED
G	GREEN	W	WHITE
GY	GRAY	Y	YELLOW

WIRING DIAGRAM
RKNL-C180/210/240/300
 575V 3 PH, 60 HZ.
 ROOFTOP W/RTU-C

DR. BY	APP. BY	DATE	DWG. NO.	REV
MGR		4-8-09	90-103079-01	01

90-103079-01 REV 01

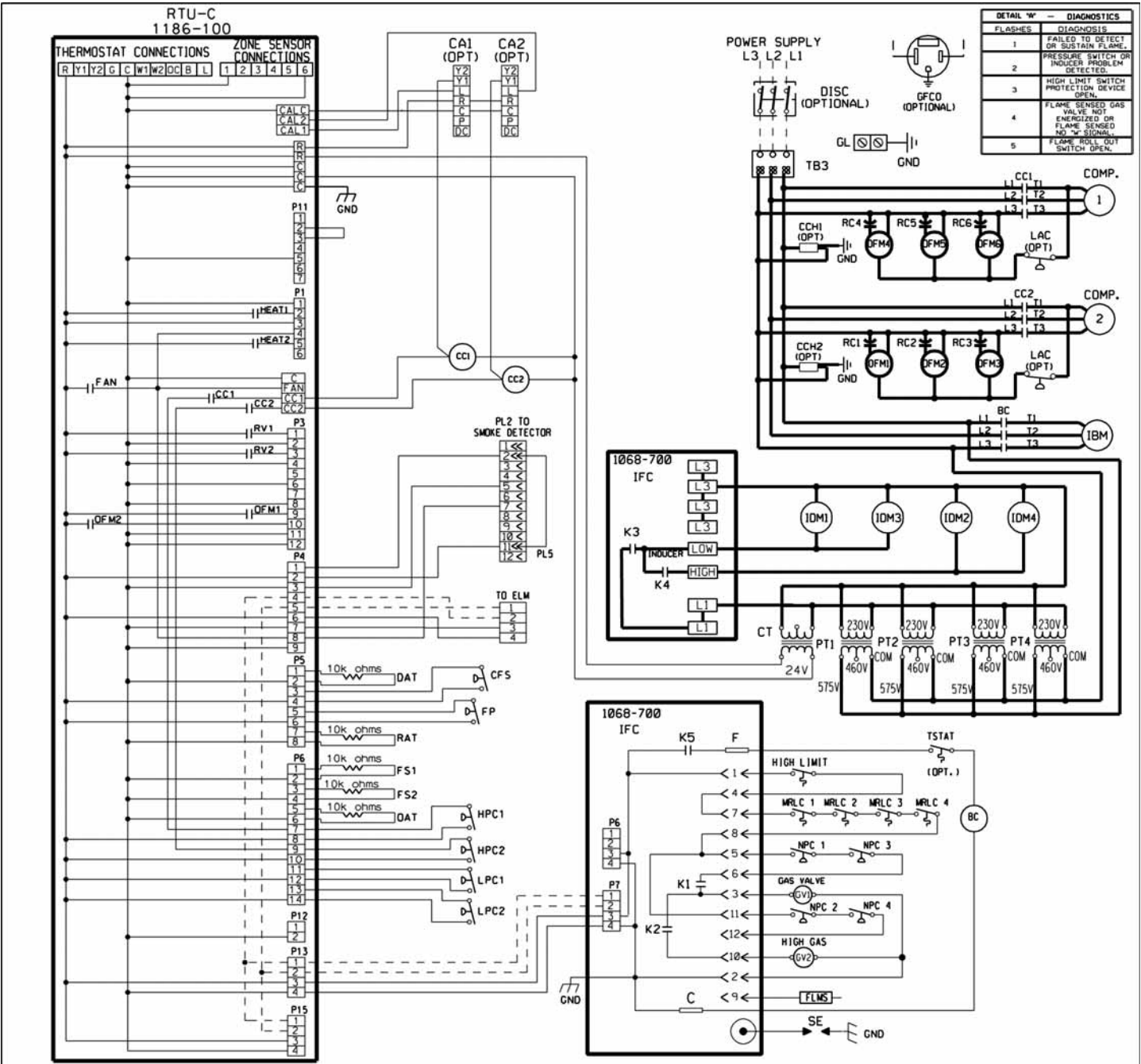

FLASHES	DIAGNOSIS
1	FAILED TO DETECT OR SUSTAIN FLAME.
2	PRESSURE SWITCH OR INDUCER PROBLEM DETECTED.
3	HIGH LIMIT SWITCH PROTECTION DEVICE OPEN.
4	FLAME SENSED GAS VALVE NOT ENERGIZED OR FLAME SENSED NO "W" SIGNAL.
5	FLAME ROLL-OUT SWITCH OPEN.

COMPONENT CODE

BC	BLOWER CONTACTOR	IDM	INDUCED DRAFT MOTOR
CA	COMFORT ALERT MODULE	IFC	INTEGRATED FURNACE CONTROL
CC	COMPRESSOR CONTACTOR	LAC	LOW AMBIENT COOLING CONTROL
CCH	CRANKCASE HEATER	LC	LIMIT CONTROL
CFS	CLOGGED FILTER SWITCH	LPC	LOW PRESSURE CONTROL
COMP	COMPRESSOR	MAS	MIX AIR SENSOR
CT	CONTROL TRANSFORMER	MRLC	MANUAL RESET LIMIT CONTROL
DISC	DISCONNECT SWITCH	NPC	NEGATIVE PRESSURE CONTROL
FLMS	FLAME SENSOR	OAT	OUTSIDE AIR SENSOR
FP	FAN PROVING	OFM	OUTDOOR FAN MOTOR
FS	FREEZE SENSOR	PL	PLUG
GFCO	GROUND FAULT CONVENIENCE OUTLET	RAT	RETURN AIR SENSOR
GL	GROUND LUG	RC	RUN CAPACITOR
GND	GROUND	SCC	SPACE COMFORT CONTROL
GV	GAS VALVE	SE	SPARK ELECTRODE
HPC	HIGH PRESSURE CONTROL	TB	TERMINAL BLOCK
IBM	INDOOR BLOWER MOTOR BELT DRIVE	WIRE NUT	

WIRING INFORMATION

LINE VOLTAGE
-FACTORY STANDARD
-FACTORY OPTION
-FIELD INSTALLED

LOW VOLTAGE
-FACTORY STANDARD
-FACTORY OPTION
-FIELD INSTALLED

REPLACEMENT WIRE
-MUST BE THE SAME SIZE AND TYPE OF INSULATION AS ORIGINAL (105°C MIN.)

WARNING
-CABINET MUST BE PERMANENTLY GROUNDED AND CONFORM TO I.E.C., N.E.C., C.E.C., AND LOCAL CODES AS APPLICABLE.

WIRE COLOR CODE

BK	BLACK	O	ORANGE
BR	BROWN	PR	PURPLE
BL	BLUE	R	RED
G	GREEN	W	WHITE
GY	GRAY	Y	YELLOW

WIRING SCHEMATIC
RKNL-C180/210/240/300
575V 3 PH, 60 HZ.
ROOFTOP W/RTU-C

DR. BY	APP. BY	DATE	DWG. NO.	REV
MGR		7-13-09		90-103263-01 00

BEFORE PURCHASING THIS APPLIANCE, READ IMPORTANT ENERGY COST AND EFFICIENCY INFORMATION AVAILABLE FROM YOUR RETAILER.

GENERAL TERMS OF LIMITED WARRANTY

Ruud will furnish a replacement for any part of this product which fails in normal use and service within the applicable periods stated, in accordance with the terms of the limited warranty.

Factory Standard Heat ExchangerTen (10) Years
Factory Option Stainless Steel Heat Exchanger
Three Phase models installed in a
commercial application.....Twenty (20) Years
Single Phase models installed in a
residential application.....Limited Lifetime

For Complete Details of the Limited Warranty, Including Applicable Terms and Conditions, See Your Local Installer or Contact the Manufacturer for a Copy.

Condenser Coil and Evaporator Coil leaks
caused by factory defectsFive (5) Years
Compressor (1 Phase, 12-SEER models)Ten (10) Years
Compressor (3 Phase models).....Five (5) Years
*Any Other PartOne (1) Year

***All other parts and components carry a limited warranty of five years, provided they are single-phase products installed in a residential application.**

Before proceeding with installation, refer to installation instructions packaged with each model, as well as complying with all Federal, State, Provincial, and Local codes, regulations, and practices.

**Ruud Heating,
Cooling and
Water Heating**

P.O. Box 17010, Fort Smith, AR 72917



"In keeping with its policy of continuous progress and product improvement, Ruud reserves the right to make changes without notice."