

SUBMITTAL SHEET FOR 14PJL SERIES 1 1/2 TO 5 NOMINAL TON [5.28 TO 17.58 kW], 14 SEER HEAT PUMP UNITS



Featuring
Earth-Friendly
R-410A Refrigerant



JOB NAME _____ LOCATION _____
 CONTRACTOR _____ ORDER NO. _____
 ENGINEER _____ UNIT MODEL NO. _____
 SUBMITTED FOR APPROVAL RECORD COIL MODEL NO. _____
 DATE _____ AIR HANDLER MODEL NO. _____

UNIT DATA

COOLING PERFORMANCE

EFFICIENCY SEER
 TOTAL CAPACITY* MBH [kW]
 SENSIBLE CAPACITY* MBH [kW]
 OUTDOOR DESIGN TEMP. °F [°C] DB
 TEMP. OF AIR ENTERING
 EVAPORATOR COIL °F [°C] DB
 °F [°C] WB
 POWER INPUT REQUIREMENT kW
 (*uses blower motor heat)

HEATING PERFORMANCE

EFFICIENCY HSPF
 TOTAL CAPACITY* MBH [kW]
 OUTDOOR DESIGN TEMP. °F [°C] DB
 TEMP. OF AIR ENTERING
 EVAPORATOR COIL °F [°C] DB

SUPPLY AIR BLOWER PERFORMANCE

TOTAL AIR SUPPLY CFM [L/s]
 TOTAL RESISTANCE EXTERNAL
 TO UNIT IWG
 BLOWER SPEED RPM
 POWER OUTPUT REQUIREMENT .. BHP
 MOTOR RATING HP [W]
 POWER INPUT REQUIREMENT kW

ELECTRICAL DATA

POWER SUPPLY Hz
 TOTAL UNIT AMPACITY AMPS
 MINIMUM WIRE SIZE AWG
 MAXIMUM OVERCURRENT DEVICE
 FUSES/HACR BREAKER AMPS

CLEARANCES

ACCESS SIDE 24" [609.6 mm]
 AIR INLETS 12" [304.8 mm]
 ABOVE UNIT 60" [1524 mm]

FEATURES FOR 14PJL SERIES HEAT PUMP UNITS 1 1/2 TO 5 NOMINAL TON [5.28 TO 17.58 kW]

- Strong, attractive cabinet-louvered design protects the coil from damage
 - Easily accessible control box
 - Grille/motor mount for quiet fan operation
 - Expansion Valves with Internal Check Valve—Provides for quieter refrigerant metering
 - Coils constructed with copper tubing and enhanced aluminum fins
 - Demand Defrost Control
 - Hot Gas Muffler
 - Service Valves
 - Non-Cycling Reversing Valve
 - Bi-Directional Filter Drier (shipped – not installed)
 - Certified and rated under ARI Standard 240
 - U.L. listed
 - Factory limited warranty on parts as follows:
 Condenser Coil leaks caused by factory defects Five (5) Years
 Conditional Compressor* Ten (10) Years
 Any Other Part Five (5) Years
- *See Product Warranty Card for Details.

ACCESSORIES/OPTIONS

- Outdoor Thermostats (Model No. RXPT-A01, A02, A03, A04) ..
 High Pressure Control (Model No. RXAB-A07)
 Low Ambient Control (Model No. RXAD-A08)
 Compressor Time Delay Control (Model No. RXMD-B01)
 Blower Time Delay Control (Model No. RXMD-C04)
 Sound Enclosure*
 Heat Pump Monitor (Model No. RXPM-B01)
 Thermostats and Subbases*
 Start Components*

*Available through the Replacement Parts Division

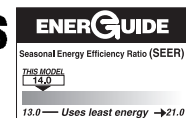

14PJL 18, 24, 30,
36, 42, 48, 60

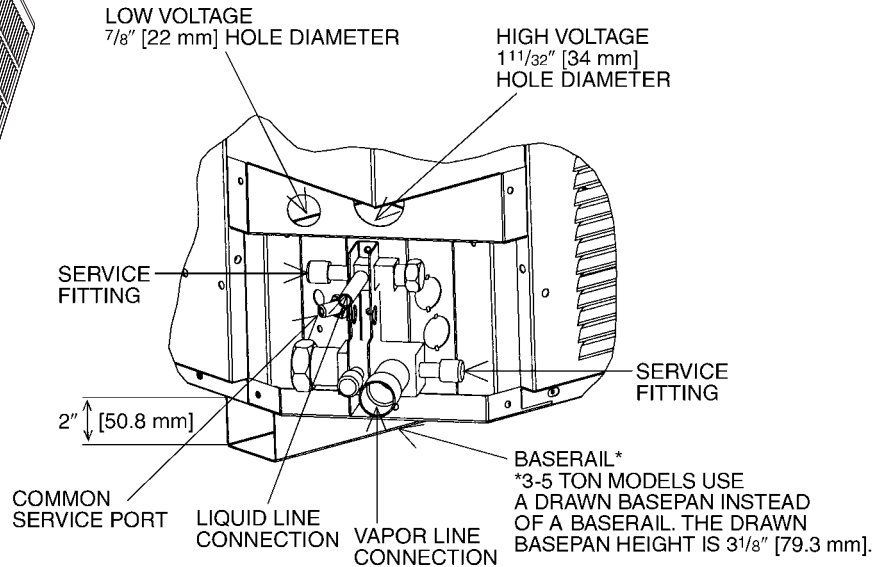
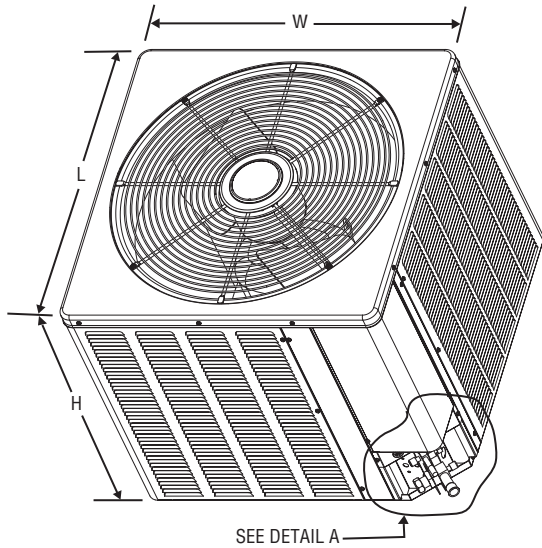

DETAIL A

Model No. 14PJL	Unit Dimensions		
	Height "H" Inches [mm]	Length "L" Inches [mm]	Width "W" Inches [mm]
18, 24	26 ¹ / ₄ [666.75]	23 ⁵ / ₈ [600]	23 ⁵ / ₈ [600]
30	26 ¹ / ₄ [666.75]	27 ⁵ / ₈ [702]	27 ⁵ / ₈ [702]
36	27 ³ / ₈ [695.32]	31 ⁵ / ₈ [803]	31 ⁵ / ₈ [803]
42, 48, 60	35 ³ / ₈ [898.52]	31 ⁵ / ₈ [803]	31 ⁵ / ₈ [803]

[] Designates Metric Conversions

NOTES:

Before proceeding with installation, refer to installation instructions packaged with each model, as well as complying with all Federal, State, Provincial, and Local codes, regulations, and practices.

"In keeping with its policy of continuous progress and product improvement, Manufacturer reserves the right to make changes without notice."