



# PACKAGE AIR CONDITIONERS

FORM NO. S11-935 REV. 5  
Supersedes Form No. S11-935 Rev. 4

## Featuring Industry Standard R-410A Refrigerant

### R-410A

### RLNL- 13 SEER SERIES NOMINAL SIZES 3-5 TONS [10.6-17.6 kW]

### RLPL- 14 SEER SERIES NOMINAL SIZES 3-5 TONS [10.6-17.6 kW]



\*Unit shown with optional louver panels installed.



(14 SEER MODELS ONLY)

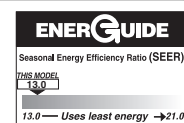
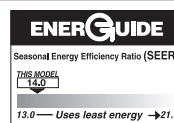

*"Proper sizing and installation of equipment is critical to achieve optimal performance. Ask your Contractor for details or visit [www.energystar.gov](http://www.energystar.gov)."*



Introduction .....	3-4
Selection Procedure .....	5
Model Identification Options .....	6-7
General Data	
RLNL- Series .....	8-16
RLPL- Series .....	17-23
General Data Notes .....	24
Performance Data	
RLNL- Series .....	25-26
RLPL- Series .....	27-28
Airflow Performance	
RLNL/RLPL- Series .....	29-36
Electrical Data	
RLNL- Series .....	37-39
RLPL- Series .....	40-42
Units with Heater Kits	
RLNL- Series .....	43-49
RLPL- Series .....	50-56
Dimensional Data .....	57-59
Accessories .....	60-67
Mechanical Specifications .....	68
Typical Wiring .....	69-74
Limited Warranty .....	76

## These quality features are included in the Rheem Package Outdoor Air Conditioning Unit

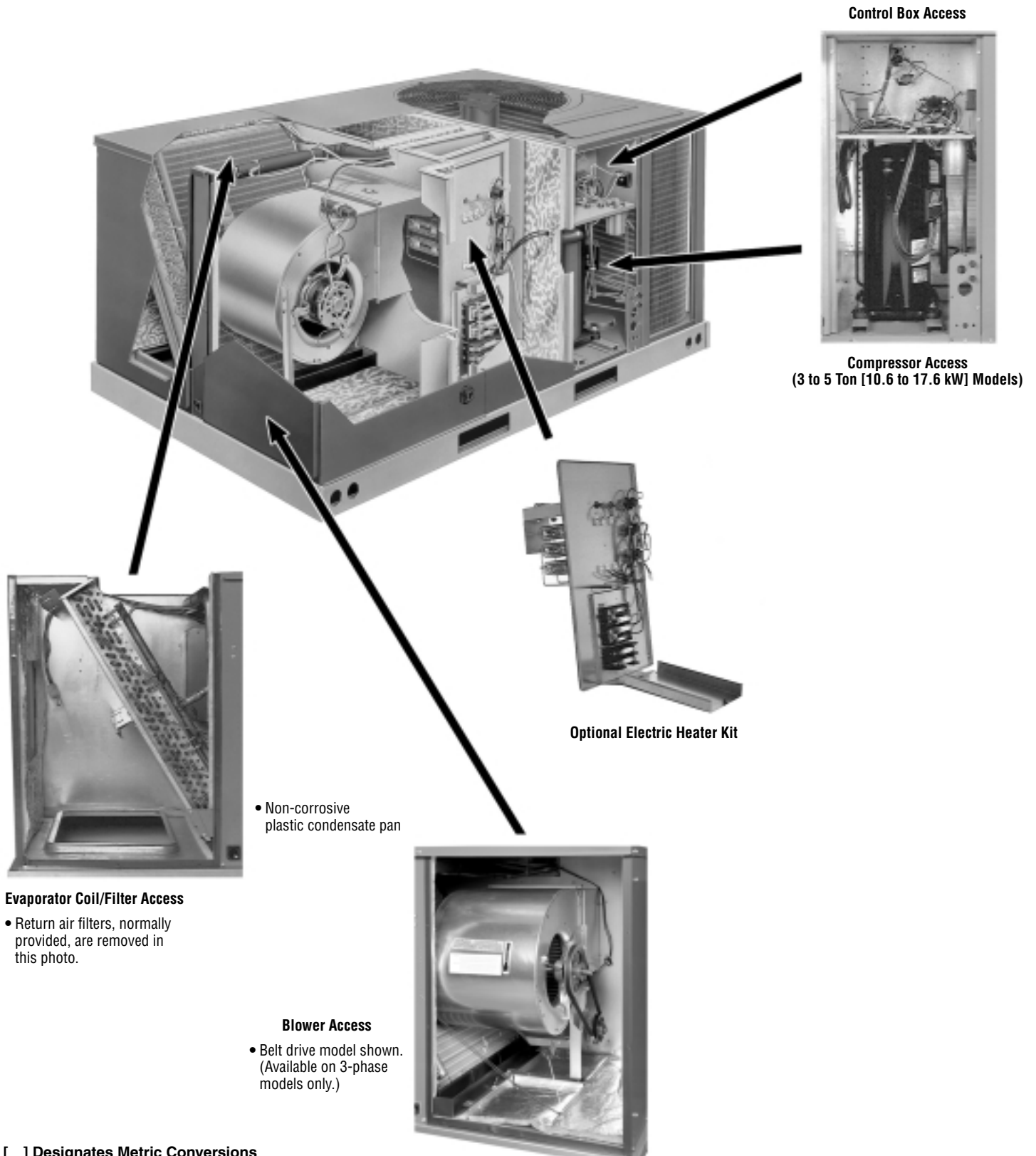

[ ] Designates Metric Conversions

## *These quality features are included in the Rheem Package Air Conditioner*



RLNL - A036, A042, A048, A060  
RLPL - A036, A042, A048, A060

### **STANDARD FEATURES INCLUDE:**

- R-410A HFC refrigerant.
- Complete factory charged, wired and run tested.
- Scroll compressors with internal line break overload and high-pressure protection.
- Single stage compressor on all models.
- Convertible airflow.
- TXV refrigerant metering system on each circuit.
- High Pressure and Low Pressure/Loss of charge protection standard on all models.
- Solid Core liquid line filter drier on each circuit.
- Single slab, single pass designed evaporator coil facilitates easy cleaning for maintained high efficiencies.
- Cooling operation up to 125 degree F ambient.
- Easily removable filter, blower, gas heat, and compressor/control access panels permits prompt service.
- Powder Paint Finish meets ASTM B117 steel coated on each side for maximum protection. G90 galvanized.
- One piece top cover and one piece base pan with drawn supply and return opening for superior water management.
- Externally mounted refrigerant gauge ports for easy service diagnostics.
- Factory or field-installed electric heat kits available up to 24 kW.
- Easy to install plug-in; slip in, 100% fully modulating economizer.
- Forkable base rails for easy handling and lifting.
- Single point electrical and gas connections.
- Direct drive or high performance belt drive motor with variable pitch pulleys and quick adjust belt system.
- Permanently lubricated evaporator, condenser and gas heat inducer motors.
- Condenser motors are internally protected, totally enclosed with shaft down design.
- 1 inch filter standard with slide out design.
- Colored and labeled wiring.
- Copper tube/Aluminum Fin coils.
- Molded compressor plug.



## RLNL- SELECTION PROCEDURES

### 1. Determine cooling and heating requirements at design conditions.

Example:

- Power supply .....208/230 - 3 Phase
- Total cooling capacity .....42,500 BTUH [12.44 kW]
- Sensible cooling capacity .....34,000 BTUH [9.96 kW]
- Heating capacity .....None
- Condenser entering air .....95°F [35°C]
- Evaporator entering air.....63°F [17°C] wb/76°F [24°C] db
- Indoor air flow .....1600 CFM [755 L/s]
- External static pressure .....1.1 in wg
- Required efficiency .....13 SEER

### 2. Select unit to meet cooling requirements.

Since total cooling is within the range of 4 ton [14.07 kW] unit and requires 13 SEER efficiency level, enter cooling performance from the RLNL-A048 table, at 95°F [35°C] outdoor temperature, 63°F [17°C] wb entering indoor air, and 1600 CFM [755 L/s]:

- Total capacity .....45,100 BTUH [13.21 kW]
- Power supply.....44,100 BTUH [12.91 kW]
- Power input .....3.6 kW

And also, at 76°F [24°C] db indoor entering air, and using the formula at the bottom of the page:

Sensible capacity .....38,327 BTUH [11.22 kW]

### 3. Determine blower speed and power to meet the system requirements.

At the given external static pressure of 1.1 in wg, the belt model must be selected. Enter the belt drive blower performance table at 1600 CFM [755 L/s] and 1.1 in wg ESP:

- RPM .....1195
- Watts .....755
- Drive .....M

### 4. Calculate indoor blower BTUH heat effect.

BTUH = Watts x 3.413 = 2577

### 5. Calculate net cooling capacities.

Net total cooling = 45,100 – 2577 = 42,523 BTUH [12.45 kW]  
Net sensible cooling = 36,908 – 2577 = 35,750 BTUH [10.06 kW]

### 6. Select Model

RLNL-A048CM000

[ ] Designates Metric Conversions

# MODEL IDENTIFICATION—RLNL/RLPL- SERIES

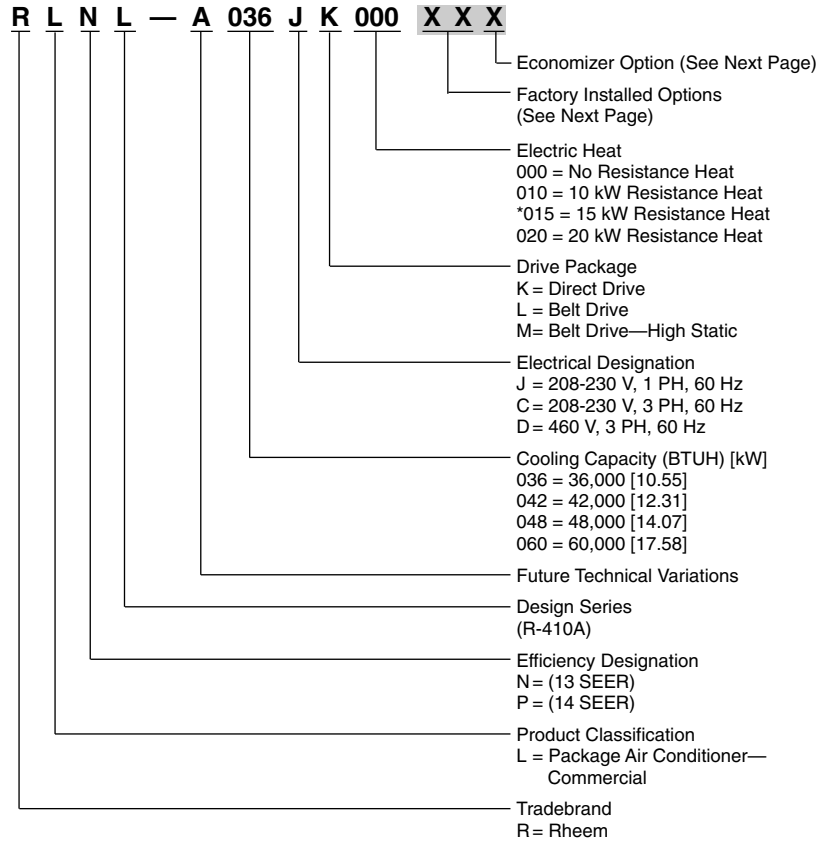

\*Electric Heat Approved for Canada

[ ] Designates Metric Conversions



**FACTORY INSTALLED OPTION CODES FOR RLNL/RLPL- (3-5 Ton) [10.6-17.6 kW] (A036, A042, A048, A060)**

Option Code	Hail Guard	Non-Powered Convenience Outlet	Low Ambient/ Freeze Stat
AD	x		
AG		x	
AP			x
BY	x		x
BJ	x	x	
CX	x	x	x
JC		x	x

Example: RLNL-A060JK000XXX (where XX is factory installed option)

Example: No Options

RLNL-A060JK000

Example: No Options with Factory Installed Economizer

RLNL-A060JK000AAB

Example: Options with Hailguard with no Factory Installed Economizer

RLNL-A060JK000ADA

Example: Options same as above with Factory Installed Economizer

RLNL-A060JK000ADB

**ECONOMIZER SELECTION FOR RLNL/RLPL- (3-5 Ton) [10.6-17.6 kW] (A036, A042, A048, A060)**

	No Economizer	Single Enthalpy Economizer With Barometric Relief
A	x	
B		x

“x” indicates factory installed option.

[ ] Designates Metric Conversions



## NOMINAL SIZES 3-5 TONS [10.6-17.6 kW]

Model RLNL- Series	A036CK	A036CL	A036CM	A036DK
<b>Cooling Performance<sup>1</sup></b>				<b>CONTINUED</b> →
Gross Cooling Capacity Btu [kW]	36,800 [10.78]	36,800 [10.78]	36,800 [10.78]	36,800 [10.78]
EER/SEER <sup>2</sup>	11.4/13	11.4/13	11.4/13	11.4/13
Nominal CFM/AHRI Rated CFM [L/s]	1200/1200 [566/566]	1200/1200 [566/566]	1200/1200 [566/566]	1200/1200 [566/566]
AHRI Net Cooling Capacity Btu [kW]	35,400 [10.37]	35,400 [10.37]	35,400 [10.37]	35,400 [10.37]
Net Sensible Capacity Btu [kW]	26,200 [7.68]	26,200 [7.68]	26,200 [7.68]	26,200 [7.68]
Net Latent Capacity Btu [kW]	9,200 [2.7]	9,200 [2.7]	9,200 [2.7]	9,200 [2.7]
Net System Power kW	3.1	3.1	3.1	3.1
<b>Compressor</b>				
No./Type	1/Scroll	1/Scroll	1/Scroll	1/Scroll
<b>Outdoor Sound Rating (dB)<sup>3</sup></b>	78	78	78	78
<b>Outdoor Coil - Fin Type</b>	Louvered	Louvered	Louvered	Louvered
Tube Type	Rifled	Rifled	Rifled	Rifled
Tube Size in. [mm] OD	0.375 [9.5]	0.375 [9.5]	0.375 [9.5]	0.375 [9.5]
Face Area sq. ft. [sq. m]	16.91 [1.57]	16.91 [1.57]	16.91 [1.57]	16.91 [1.57]
Rows / FPI [FPcm]	1 / 22 [9]	1 / 22 [9]	1 / 22 [9]	1 / 22 [9]
<b>Indoor Coil - Fin Type</b>	Corrugated	Corrugated	Corrugated	Corrugated
Tube Type	Rifled	Rifled	Rifled	Rifled
Tube Size in. [mm]	0.375 [9.5]	0.375 [9.5]	0.375 [9.5]	0.375 [9.5]
Face Area sq. ft. [sq. m]	5.17 [0.48]	5.17 [0.48]	5.17 [0.48]	5.17 [0.48]
Rows / FPI [FPcm]	2 / 17 [7]	2 / 17 [7]	2 / 17 [7]	2 / 17 [7]
Refrigerant Control	TX Valves	TX Valves	TX Valves	TX Valves
Drain Connection No./Size in. [mm]	1/0.75 [19.05]	1/0.75 [19.05]	1/0.75 [19.05]	1/0.75 [19.05]
<b>Outdoor Fan - Type</b>	Propeller	Propeller	Propeller	Propeller
No. Used/Diameter in. [mm]	1/24 [609.6]	1/24 [609.6]	1/24 [609.6]	1/24 [609.6]
Drive Type/No. Speeds	Direct/1	Direct/1	Direct/1	Direct/1
CFM [L/s]	3680 [1737]	3680 [1737]	3680 [1737]	3680 [1737]
No. Motors/HP	1 at 1/3 HP	1 at 1/3 HP	1 at 1/3 HP	1 at 1/3 HP
Motor RPM	1075	1075	1075	1075
<b>Indoor Fan - Type</b>	FC Centrifugal	FC Centrifugal	FC Centrifugal	FC Centrifugal
No. Used/Diameter in. [mm]	1/10x10 [254x254]	1/10x10 [254x254]	1/10x10 [254x254]	1/10x10 [254x254]
Drive Type/No. Speeds	Direct/3	Belt/Variable	Belt/Variable	Direct/3
No. Motors	1	1	1	1
Motor HP	1/2	1/2	3/4	1/2
Motor RPM	1075	1725	1725	1075
Motor Frame Size	48	48	56	48
<b>Filter - Type</b>	Disposable	Disposable	Disposable	Disposable
Furnished	Yes	Yes	Yes	Yes
(NO.) Size Recommended in. [mm x mm x mm]	(1)1x16x25 [25x406x635]	(1)1x16x25 [25x406x635]	(1)1x16x25 [25x406x635]	(1)1x16x25 [25x406x635]
	(1)1x16x25 [25x406x635]	(1)1x16x25 [25x406x635]	(1)1x16x25 [25x406x635]	(1)1x16x25 [25x406x635]
<b>Refrigerant Charge Oz. [g]</b>	96 [2722]	96 [2722]	96 [2722]	96 [2722]
<b>Weights</b>				
Net Weight lbs. [kg]	543 [246]	543 [246]	543 [246]	543 [246]
Ship Weight lbs. [kg]	550 [249]	550 [249]	550 [249]	550 [249]

See Page 24 for Notes.

[ ] Designates Metric Conversions



**NOMINAL SIZES 3-5 TONS [10.6-17.6 kW]**

Model RLNL- Series	A036DL	A036DM	A036JK	A036YL
<b>Cooling Performance<sup>1</sup></b>				<b>CONTINUED →</b>
Gross Cooling Capacity Btu [kW]	36,800 [10.78]	36,800 [10.78]	36,800 [10.78]	42,500 [12.45]
EER/SEER <sup>2</sup>	11.4/13	11.4/13	11.4/13	11.4/13
Nominal CFM/AHRI Rated CFM [L/s]	1200/1200 [566/566]	1200/1200 [566/566]	1200/1200 [566/566]	1200/1200 [566/566]
AHRI Net Cooling Capacity Btu [kW]	35,400 [10.37]	35,400 [10.37]	35,400 [10.37]	35,400 [10.37]
Net Sensible Capacity Btu [kW]	26,200 [7.68]	26,200 [7.68]	26,200 [7.68]	26,200 [7.68]
Net Latent Capacity Btu [kW]	9,200 [2.7]	9,200 [2.7]	9,200 [2.7]	9,200 [2.7]
Net System Power kW	3.1	3.1	3.1	3.1
<b>Compressor</b>				
No./Type	1/Scroll	1/Scroll	1/Scroll	1/Scroll
<b>Outdoor Sound Rating (dB)<sup>3</sup></b>	78	78	78	78
<b>Outdoor Coil - Fin Type</b>	Louvered	Louvered	Louvered	Louvered
Tube Type	Rifled	Rifled	Rifled	Rifled
Tube Size in. [mm] OD	0.375 [9.5]	0.375 [9.5]	0.375 [9.5]	0.375 [9.5]
Face Area sq. ft. [sq. m]	16.91 [1.57]	16.91 [1.57]	16.91 [1.57]	16.91 [1.57]
Rows / FPI [FPcm]	1 / 22 [9]	1 / 22 [9]	1 / 22 [9]	1 / 22 [9]
<b>Indoor Coil - Fin Type</b>	Corrugated	Corrugated	Corrugated	Corrugated
Tube Type	Rifled	Rifled	Rifled	Rifled
Tube Size in. [mm]	0.375 [9.5]	0.375 [9.5]	0.375 [9.5]	0.375 [9.5]
Face Area sq. ft. [sq. m]	5.17 [0.48]	5.17 [0.48]	5.17 [0.48]	5.17 [0.48]
Rows / FPI [FPcm]	2 / 17 [7]	2 / 17 [7]	2 / 17 [7]	2 / 17 [7]
Refrigerant Control	TX Valves	TX Valves	TX Valves	TX Valves
Drain Connection No./Size in. [mm]	1/0.75 [19.05]	1/0.75 [19.05]	1/0.75 [19.05]	1/0.75 [19.05]
<b>Outdoor Fan - Type</b>	Propeller	Propeller	Propeller	Propeller
No. Used/Diameter in. [mm]	1/24 [609.6]	1/24 [609.6]	1/24 [609.6]	1/24 [609.6]
Drive Type/No. Speeds	Direct/1	Direct/1	Direct/1	Direct/1
CFM [L/s]	3680 [1737]	3680 [1737]	3680 [1737]	3680 [1737]
No. Motors/HP	1 at 1/3 HP	1 at 1/3 HP	1 at 1/3 HP	1 at 1/3 HP
Motor RPM	1075	1075	1075	1075
<b>Indoor Fan - Type</b>	FC Centrifugal	FC Centrifugal	FC Centrifugal	FC Centrifugal
No. Used/Diameter in. [mm]	1/10x10 [254x254]	1/10x10 [254x254]	1/10x10 [254x254]	1/10x10 [254x254]
Drive Type/No. Speeds	Belt/Variable	Belt/Variable	Direct/3	Belt/Variable
No. Motors	1	1	1	1
Motor HP	1/2	3/4	1/2	3/4
Motor RPM	1725	1725	1075	1725
Motor Frame Size	48	56	48	56
<b>Filter - Type</b>	Disposable	Disposable	Disposable	Disposable
Furnished	Yes	Yes	Yes	Yes
(NO.) Size Recommended in. [mm x mm x mm]	(1)1x16x25 [25x406x635]	(1)1x16x25 [25x406x635]	(1)1x16x25 [25x406x635]	(1)1x16x25 [25x406x635]
	(1)1x16x25 [25x406x635]	(1)1x16x25 [25x406x635]	(1)1x16x25 [25x406x635]	(1)1x16x25 [25x406x635]
<b>Refrigerant Charge Oz. [g]</b>	96 [2722]	96 [2722]	96 [2722]	96 [2722]
<b>Weights</b>				
Net Weight lbs. [kg]	543 [246]	543 [246]	543 [246]	543 [246]
Ship Weight lbs. [kg]	550 [249]	550 [249]	550 [249]	550 [249]

See Page 24 for Notes.

[ ] Designates Metric Conversions



## NOMINAL SIZES 3-5 TONS [10.6-17.6 kW]

Model RLNL- Series	A036YM	A042CK	A042CL	A042CM
<b>Cooling Performance<sup>1</sup></b>				<b>CONTINUED</b> →
Gross Cooling Capacity Btu [kW]	42,500 [12.45]	42,500 [12.45]	42,500 [12.45]	42,500 [12.45]
EER/SEER <sup>2</sup>	11.4/13	11.2/13	11.2/13	11.2/13
Nominal CFM/AHRI Rated CFM [L/s]	1200/1200 [566/566]	1400/1450 [661/684]	1400/1450 [661/684]	1400/1450 [661/684]
AHRI Net Cooling Capacity Btu [kW]	35,400 [10.37]	40,500 [11.87]	40,500 [11.87]	40,500 [11.87]
Net Sensible Capacity Btu [kW]	26,200 [7.68]	30,600 [8.97]	30,600 [8.97]	30,600 [8.97]
Net Latent Capacity Btu [kW]	9,200 [2.7]	9,900 [2.9]	9,900 [2.9]	9,900 [2.9]
Net System Power kW	3.1	3.62	3.62	3.62
<b>Compressor</b>				
No./Type	1/Scroll	1/Scroll	1/Scroll	1/Scroll
<b>Outdoor Sound Rating (dB)<sup>3</sup></b>	78	78	78	78
<b>Outdoor Coil - Fin Type</b>	Louvered	Louvered	Louvered	Louvered
Tube Type	Rifled	Rifled	Rifled	Rifled
Tube Size in. [mm] OD	0.375 [9.5]	0.375 [9.5]	0.375 [9.5]	0.375 [9.5]
Face Area sq. ft. [sq. m]	16.91 [1.57]	16.91 [1.57]	16.91 [1.57]	16.91 [1.57]
Rows / FPI [FPcm]	1 / 22 [9]	1.53 / 22 [9]	1.53 / 22 [9]	1.53 / 22 [9]
<b>Indoor Coil - Fin Type</b>	Corrugated	Corrugated	Corrugated	Corrugated
Tube Type	Rifled	Rifled	Rifled	Rifled
Tube Size in. [mm]	0.375 [9.5]	0.375 [9.5]	0.375 [9.5]	0.375 [9.5]
Face Area sq. ft. [sq. m]	5.17 [0.48]	5.17 [0.48]	5.17 [0.48]	5.17 [0.48]
Rows / FPI [FPcm]	2 / 17 [7]	3 / 13 [5]	3 / 13 [5]	3 / 13 [5]
Refrigerant Control	TX Valves	TX Valves	TX Valves	TX Valves
Drain Connection No./Size in. [mm]	1/0.75 [19.05]	1/0.75 [19.05]	1/0.75 [19.05]	1/0.75 [19.05]
<b>Outdoor Fan - Type</b>	Propeller	Propeller	Propeller	Propeller
No. Used/Diameter in. [mm]	1/24 [609.6]	1/24 [609.6]	1/24 [609.6]	1/24 [609.6]
Drive Type/No. Speeds	Direct/1	Direct/1	Direct/1	Direct/1
CFM [L/s]	3680 [1737]	3680 [1737]	3680 [1737]	3680 [1737]
No. Motors/HP	1 at 1/3 HP	1 at 1/3 HP	1 at 1/3 HP	1 at 1/3 HP
Motor RPM	1075	1075	1075	1075
<b>Indoor Fan - Type</b>	FC Centrifugal	FC Centrifugal	FC Centrifugal	FC Centrifugal
No. Used/Diameter in. [mm]	1/10x10 [254x254]	1/10x10 [254x254]	1/10x10 [254x254]	1/10x10 [254x254]
Drive Type/No. Speeds	Belt/Variable	Direct/3	Belt/Variable	Belt/Variable
No. Motors	1	1	1	1
Motor HP	3/4	1/2	1/2	3/4
Motor RPM	1725	1075	1725	1725
Motor Frame Size	56	48	48	56
<b>Filter - Type</b>	Disposable	Disposable	Disposable	Disposable
Furnished	Yes	Yes	Yes	Yes
(NO.) Size Recommended in. [mm x mm x mm]	(1)1x16x25 [25x406x635]	(1)1x16x25 [25x406x635]	(1)1x16x25 [25x406x635]	(1)1x16x25 [25x406x635]
	(1)1x16x25 [25x406x635]	(1)1x16x25 [25x406x635]	(1)1x16x25 [25x406x635]	(1)1x16x25 [25x406x635]
<b>Refrigerant Charge Oz. [g]</b>	96 [2722]	125 [3544]	125 [3544]	125 [3544]
<b>Weights</b>				
Net Weight lbs. [kg]	543 [246]	570 [259]	570 [259]	570 [259]
Ship Weight lbs. [kg]	550 [249]	577 [262]	577 [262]	577 [262]

See Page 24 for Notes.

[ ] Designates Metric Conversions



**NOMINAL SIZES 3-5 TONS [10.6-17.6 kW]**

Model RLNL- Series	A042DK	A042DL	A042DM	A042JK
<b>Cooling Performance<sup>1</sup></b>				<b>CONTINUED →</b>
Gross Cooling Capacity Btu [kW]	42,500 [12.45]	42,500 [12.45]	42,500 [12.45]	50,000 [14.65]
EER/SEER <sup>2</sup>	11.2/13	11.2/13	11.2/13	11.2/13
Nominal CFM/AHRI Rated CFM [L/s]	1400/1450 [661/684]	1400/1450 [661/684]	1400/1450 [661/684]	1400/1450 [661/684]
AHRI Net Cooling Capacity Btu [kW]	40,500 [11.87]	40,500 [11.87]	40,500 [11.87]	40,500 [11.87]
Net Sensible Capacity Btu [kW]	30,600 [8.97]	30,600 [8.97]	30,600 [8.97]	30,600 [8.97]
Net Latent Capacity Btu [kW]	9,900 [2.9]	9,900 [2.9]	9,900 [2.9]	9,900 [2.9]
Net System Power kW	3.62	3.62	3.62	3.62
<b>Compressor</b>				
No./Type	1/Scroll	1/Scroll	1/Scroll	1/Scroll
<b>Outdoor Sound Rating (dB)<sup>3</sup></b>	78	78	78	78
<b>Outdoor Coil - Fin Type</b>	Louvered	Louvered	Louvered	Louvered
Tube Type	Rifled	Rifled	Rifled	Rifled
Tube Size in. [mm] OD	0.375 [9.5]	0.375 [9.5]	0.375 [9.5]	0.375 [9.5]
Face Area sq. ft. [sq. m]	16.91 [1.57]	16.91 [1.57]	16.91 [1.57]	16.91 [1.57]
Rows / FPI [FPcm]	1.53 / 22 [9]	1.53 / 22 [9]	1.53 / 22 [9]	1.53 / 22 [9]
<b>Indoor Coil - Fin Type</b>	Corrugated	Corrugated	Corrugated	Corrugated
Tube Type	Rifled	Rifled	Rifled	Rifled
Tube Size in. [mm]	0.375 [9.5]	0.375 [9.5]	0.375 [9.5]	0.375 [9.5]
Face Area sq. ft. [sq. m]	5.17 [0.48]	5.17 [0.48]	5.17 [0.48]	5.17 [0.48]
Rows / FPI [FPcm]	3 / 13 [5]	3 / 13 [5]	3 / 13 [5]	3 / 13 [5]
Refrigerant Control	TX Valves	TX Valves	TX Valves	TX Valves
Drain Connection No./Size in. [mm]	1/0.75 [19.05]	1/0.75 [19.05]	1/0.75 [19.05]	1/0.75 [19.05]
<b>Outdoor Fan - Type</b>	Propeller	Propeller	Propeller	Propeller
No. Used/Diameter in. [mm]	1/24 [609.6]	1/24 [609.6]	1/24 [609.6]	1/24 [609.6]
Drive Type/No. Speeds	Direct/1	Direct/1	Direct/1	Direct/1
CFM [L/s]	3680 [1737]	3680 [1737]	3680 [1737]	3680 [1737]
No. Motors/HP	1 at 1/3 HP	1 at 1/3 HP	1 at 1/3 HP	1 at 1/3 HP
Motor RPM	1075	1075	1075	1075
<b>Indoor Fan - Type</b>	FC Centrifugal	FC Centrifugal	FC Centrifugal	FC Centrifugal
No. Used/Diameter in. [mm]	1/10x10 [254x254]	1/10x10 [254x254]	1/10x10 [254x254]	1/10x10 [254x254]
Drive Type/No. Speeds	Direct/3	Belt/Variable	Belt/Variable	Direct/3
No. Motors	1	1	1	1
Motor HP	1/2	1/2	3/4	1/2
Motor RPM	1075	1725	1725	1075
Motor Frame Size	48	48	56	48
<b>Filter - Type</b>	Disposable	Disposable	Disposable	Disposable
Furnished	Yes	Yes	Yes	Yes
(NO.) Size Recommended in. [mm x mm x mm]	(1)1x16x25 [25x406x635]	(1)1x16x25 [25x406x635]	(1)1x16x25 [25x406x635]	(1)1x16x25 [25x406x635]
	(1)1x16x25 [25x406x635]	(1)1x16x25 [25x406x635]	(1)1x16x25 [25x406x635]	(1)1x16x25 [25x406x635]
<b>Refrigerant Charge Oz. [g]</b>	125 [3544]	125 [3544]	125 [3544]	125 [3544]
<b>Weights</b>				
Net Weight lbs. [kg]	570 [259]	570 [259]	570 [259]	570 [259]
Ship Weight lbs. [kg]	577 [262]	577 [262]	577 [262]	577 [262]

See Page 24 for Notes.

[ ] Designates Metric Conversions



## NOMINAL SIZES 3-5 TONS [10.6-17.6 kW]

Model RLNL- Series	A048CK	A048CL	A048CM	A048DK
<b>Cooling Performance<sup>1</sup></b>				<b>CONTINUED</b> →
Gross Cooling Capacity Btu [kW]	50,000 [14.65]	50,000 [14.65]	50,000 [14.65]	50,000 [14.65]
EER/SEER <sup>2</sup>	11.45/13	11.45/13	11.45/13	11.45/13
Nominal CFM/AHRI Rated CFM [L/s]	1600/1600 [755/755]	1600/1600 [755/755]	1600/1600 [755/755]	1600/1600 [755/755]
AHRI Net Cooling Capacity Btu [kW]	48,000 [14.06]	48,000 [14.06]	48,000 [14.06]	48,000 [14.06]
Net Sensible Capacity Btu [kW]	35,600 [10.43]	35,600 [10.43]	35,600 [10.43]	35,600 [10.43]
Net Latent Capacity Btu [kW]	12,400 [3.63]	12,400 [3.63]	12,400 [3.63]	12,400 [3.63]
Net System Power kW	4.19	4.19	4.19	4.19
<b>Compressor</b>				
No./Type	1/Scroll	1/Scroll	1/Scroll	1/Scroll
<b>Outdoor Sound Rating (dB)<sup>3</sup></b>	78	78	78	78
<b>Outdoor Coil - Fin Type</b>	Louvered	Louvered	Louvered	Louvered
Tube Type	Rifled	Rifled	Rifled	Rifled
Tube Size in. [mm] OD	0.375 [9.5]	0.375 [9.5]	0.375 [9.5]	0.375 [9.5]
Face Area sq. ft. [sq. m]	16.56 [1.54]	16.56 [1.54]	16.56 [1.54]	16.56 [1.54]
Rows / FPI [FPcm]	2 / 22 [9]	2 / 22 [9]	2 / 22 [9]	2 / 22 [9]
<b>Indoor Coil - Fin Type</b>	Corrugated	Corrugated	Corrugated	Corrugated
Tube Type	Rifled	Rifled	Rifled	Rifled
Tube Size in. [mm]	0.375 [9.5]	0.375 [9.5]	0.375 [9.5]	0.375 [9.5]
Face Area sq. ft. [sq. m]	5.17 [0.48]	5.17 [0.48]	5.17 [0.48]	5.17 [0.48]
Rows / FPI [FPcm]	3 / 15 [6]	3 / 15 [6]	3 / 15 [6]	3 / 15 [6]
Refrigerant Control	TX Valves	TX Valves	TX Valves	TX Valves
Drain Connection No./Size in. [mm]	1/0.75 [19.05]	1/0.75 [19.05]	1/0.75 [19.05]	1/0.75 [19.05]
<b>Outdoor Fan - Type</b>	Propeller	Propeller	Propeller	Propeller
No. Used/Diameter in. [mm]	1/24 [609.6]	1/24 [609.6]	1/24 [609.6]	1/24 [609.6]
Drive Type/No. Speeds	Direct/1	Direct/1	Direct/1	Direct/1
CFM [L/s]	3680 [1737]	3680 [1737]	3680 [1737]	3680 [1737]
No. Motors/HP	1 at 1/3 HP	1 at 1/3 HP	1 at 1/3 HP	1 at 1/3 HP
Motor RPM	1075	1075	1075	1075
<b>Indoor Fan - Type</b>	FC Centrifugal	FC Centrifugal	FC Centrifugal	FC Centrifugal
No. Used/Diameter in. [mm]	1/10x10 [254x254]	1/10x10 [254x254]	1/10x10 [254x254]	1/10x10 [254x254]
Drive Type/No. Speeds	Direct/3	Belt/Variable	Belt/Variable	Direct/3
No. Motors	1	1	1	1
Motor HP	1/2	1/2	3/4	1/2
Motor RPM	1075	1725	1725	1075
Motor Frame Size	48	48	56	48
<b>Filter - Type</b>	Disposable	Disposable	Disposable	Disposable
Furnished	Yes	Yes	Yes	Yes
(NO.) Size Recommended in. [mm x mm x mm]	(1)1x16x25 [25x406x635] (1)1x16x25 [25x406x635]	(1)1x16x25 [25x406x635] (1)1x16x25 [25x406x635]	(1)1x16x25 [25x406x635] (1)1x16x25 [25x406x635]	(1)1x16x25 [25x406x635] (1)1x16x25 [25x406x635]
<b>Refrigerant Charge Oz. [g]</b>	165 [4678]	165 [4678]	165 [4678]	165 [4678]
<b>Weights</b>				
Net Weight lbs. [kg]	580 [263]	580 [263]	580 [263]	580 [263]
Ship Weight lbs. [kg]	587 [266]	587 [266]	587 [266]	587 [266]

See Page 24 for Notes.

[ ] Designates Metric Conversions



**NOMINAL SIZES 3-5 TONS [10.6-17.6 kW]**

Model RLNL- Series	A048DL	A048DM	A048JK	A048YL
<b>Cooling Performance<sup>1</sup></b>				<b>CONTINUED →</b>
Gross Cooling Capacity Btu [kW]	50,000 [14.65]	50,000 [14.65]	50,000 [14.65]	61,000 [17.87]
EER/SEER <sup>2</sup>	11.45/13	11.45/13	11.45/13	11.45/13
Nominal CFM/AHRI Rated CFM [L/s]	1600/1600 [755/755]	1600/1600 [755/755]	1600/1600 [755/755]	1600/1600 [755/755]
AHRI Net Cooling Capacity Btu [kW]	48,000 [14.06]	48,000 [14.06]	48,000 [14.06]	48,000 [14.06]
Net Sensible Capacity Btu [kW]	35,600 [10.43]	35,600 [10.43]	35,600 [10.43]	35,600 [10.43]
Net Latent Capacity Btu [kW]	12,400 [3.63]	12,400 [3.63]	12,400 [3.63]	12,400 [3.63]
Net System Power kW	4.19	4.19	4.19	4.19
<b>Compressor</b>				
No./Type	1/Scroll	1/Scroll	1/Scroll	1/Scroll
<b>Outdoor Sound Rating (dB)<sup>3</sup></b>	78	78	78	78
<b>Outdoor Coil - Fin Type</b>	Louvered	Louvered	Louvered	Louvered
Tube Type	Rifled	Rifled	Rifled	Rifled
Tube Size in. [mm] OD	0.375 [9.5]	0.375 [9.5]	0.375 [9.5]	0.375 [9.5]
Face Area sq. ft. [sq. m]	16.56 [1.54]	16.56 [1.54]	16.56 [1.54]	16.56 [1.54]
Rows / FPI [FPcm]	2 / 22 [9]	2 / 22 [9]	2 / 22 [9]	2 / 22 [9]
<b>Indoor Coil - Fin Type</b>	Corrugated	Corrugated	Corrugated	Corrugated
Tube Type	Rifled	Rifled	Rifled	Rifled
Tube Size in. [mm]	0.375 [9.5]	0.375 [9.5]	0.375 [9.5]	0.375 [9.5]
Face Area sq. ft. [sq. m]	5.17 [0.48]	5.17 [0.48]	5.17 [0.48]	5.17 [0.48]
Rows / FPI [FPcm]	3 / 15 [6]	3 / 15 [6]	3 / 15 [6]	3 / 15 [6]
Refrigerant Control	TX Valves	TX Valves	TX Valves	TX Valves
Drain Connection No./Size in. [mm]	1/0.75 [19.05]	1/0.75 [19.05]	1/0.75 [19.05]	1/0.75 [19.05]
<b>Outdoor Fan - Type</b>	Propeller	Propeller	Propeller	Propeller
No. Used/Diameter in. [mm]	1/24 [609.6]	1/24 [609.6]	1/24 [609.6]	1/24 [609.6]
Drive Type/No. Speeds	Direct/1	Direct/1	Direct/1	Direct/1
CFM [L/s]	3680 [1737]	3680 [1737]	3680 [1737]	3680 [1737]
No. Motors/HP	1 at 1/3 HP	1 at 1/3 HP	1 at 1/3 HP	1 at 1/3 HP
Motor RPM	1075	1075	1075	1075
<b>Indoor Fan - Type</b>	FC Centrifugal	FC Centrifugal	FC Centrifugal	FC Centrifugal
No. Used/Diameter in. [mm]	1/10x10 [254x254]	1/10x10 [254x254]	1/10x10 [254x254]	1/10x10 [254x254]
Drive Type/No. Speeds	Belt/Variable	Belt/Variable	Direct/3	Belt/Variable
No. Motors	1	1	1	1
Motor HP	1/2	3/4	1/2	3/4
Motor RPM	1725	1725	1075	1725
Motor Frame Size	48	56	48	56
<b>Filter - Type</b>	Disposable	Disposable	Disposable	Disposable
Furnished	Yes	Yes	Yes	Yes
(NO.) Size Recommended in. [mm x mm x mm]	(1)1x16x25 [25x406x635] (1)1x16x25 [25x406x635]	(1)1x16x25 [25x406x635] (1)1x16x25 [25x406x635]	(1)1x16x25 [25x406x635] (1)1x16x25 [25x406x635]	(1)1x16x25 [25x406x635] (1)1x16x25 [25x406x635]
<b>Refrigerant Charge Oz. [g]</b>	165 [4678]	165 [4678]	165 [4678]	165 [4678]
<b>Weights</b>				
Net Weight lbs. [kg]	580 [263]	580 [263]	580 [263]	580 [263]
Ship Weight lbs. [kg]	587 [266]	587 [266]	587 [266]	587 [266]

See Page 24 for Notes.

[ ] Designates Metric Conversions



## NOMINAL SIZES 3-5 TONS [10.6-17.6 kW]

Model RLNL- Series	A048YM	A060CK	A060CL	A060CM
<b>Cooling Performance<sup>1</sup></b>				<b>CONTINUED</b> →
Gross Cooling Capacity Btu [kW]	50,000 [14.65]	61,000 [17.87]	61,000 [17.87]	61,000 [17.87]
EER/SEER <sup>2</sup>	11.45/13	11.1/13	11.1/13	11.1/13
Nominal CFM/AHRI Rated CFM [L/s]	1600/1600 [755/755]	2000/1900 [944/897]	2000/1900 [944/897]	2000/1900 [944/897]
AHRI Net Cooling Capacity Btu [kW]	48,000 [14.06]	59,000 [17.29]	59,000 [17.29]	59,000 [17.29]
Net Sensible Capacity Btu [kW]	35,600 [10.43]	42,000 [12.31]	42,000 [12.31]	42,000 [12.31]
Net Latent Capacity Btu [kW]	12,400 [3.63]	17,000 [4.98]	17,000 [4.98]	17,000 [4.98]
Net System Power kW	4.19	5.32	5.32	5.32
<b>Compressor</b>				
No./Type	1/Scroll	1/Scroll	1/Scroll	1/Scroll
<b>Outdoor Sound Rating (dB)<sup>3</sup></b>	78	83	83	83
<b>Outdoor Coil - Fin Type</b>	Louvered	Louvered	Louvered	Louvered
Tube Type	Rifled	Rifled	Rifled	Rifled
Tube Size in. [mm] OD	0.375 [9.5]	0.375 [9.5]	0.375 [9.5]	0.375 [9.5]
Face Area sq. ft. [sq. m]	16.56 [1.54]	16.56 [1.54]	16.56 [1.54]	16.56 [1.54]
Rows / FPI [FPcm]	2 / 22 [9]	2 / 22 [9]	2 / 22 [9]	2 / 22 [9]
<b>Indoor Coil - Fin Type</b>	Corrugated	Corrugated	Corrugated	Corrugated
Tube Type	Rifled	Rifled	Rifled	Rifled
Tube Size in. [mm]	0.375 [9.5]	0.375 [9.5]	0.375 [9.5]	0.375 [9.5]
Face Area sq. ft. [sq. m]	5.17 [0.48]	5.17 [0.48]	5.17 [0.48]	5.17 [0.48]
Rows / FPI [FPcm]	3 / 15 [6]	3 / 15 [6]	3 / 15 [6]	3 / 15 [6]
Refrigerant Control	TX Valves	TX Valves	TX Valves	TX Valves
Drain Connection No./Size in. [mm]	1/0.75 [19.05]	1/0.75 [19.05]	1/0.75 [19.05]	1/0.75 [19.05]
<b>Outdoor Fan - Type</b>	Propeller	Propeller	Propeller	Propeller
No. Used/Diameter in. [mm]	1/24 [609.6]	1/24 [609.6]	1/24 [609.6]	1/24 [609.6]
Drive Type/No. Speeds	Direct/1	Direct/1	Direct/1	Direct/1
CFM [L/s]	3680 [1737]	3930 [1855]	3930 [1855]	3930 [1855]
No. Motors/HP	1 at 1/3 HP	1 at 1/3 HP	1 at 1/3 HP	1 at 1/3 HP
Motor RPM	1075	1075	1075	1075
<b>Indoor Fan - Type</b>	FC Centrifugal	FC Centrifugal	FC Centrifugal	FC Centrifugal
No. Used/Diameter in. [mm]	1/10x10 [254x254]	1/10x10 [254x254]	1/10x10 [254x254]	1/10x10 [254x254]
Drive Type/No. Speeds	Belt/Variable	Direct/3	Belt/Variable	Belt/Variable
No. Motors	1	1	1	1
Motor HP	3/4	1	3/4	1
Motor RPM	1725	1075	1725	1725
Motor Frame Size	56	48	56	56
<b>Filter - Type</b>	Disposable	Disposable	Disposable	Disposable
Furnished	Yes	Yes	Yes	Yes
(NO.) Size Recommended in. [mm x mm x mm]	(1)1x16x25 [25x406x635] (1)1x16x25 [25x406x635]	(1)1x16x25 [25x406x635] (1)1x16x25 [25x406x635]	(1)1x16x25 [25x406x635] (1)1x16x25 [25x406x635]	(1)1x16x25 [25x406x635] (1)1x16x25 [25x406x635]
<b>Refrigerant Charge Oz. [g]</b>	165 [4678]	160 [4536]	160 [4536]	160 [4536]
<b>Weights</b>				
Net Weight lbs. [kg]	580 [263]	590 [268]	590 [268]	590 [268]
Ship Weight lbs. [kg]	587 [266]	597 [271]	597 [271]	597 [271]

See Page 24 for Notes.

[ ] Designates Metric Conversions



**NOMINAL SIZES 3-5 TONS [10.6-17.6 kW]**

Model RLNL- Series	A060DK	A060DL	A060DM	A060JK
<b>Cooling Performance<sup>1</sup></b>				<b>CONTINUED →</b>
Gross Cooling Capacity Btu [kW]	61,000 [17.87]	61,000 [17.87]	61,000 [17.87]	61,000 [17.87]
EER/SEER <sup>2</sup>	11.1/13	11.1/13	11.1/13	11.1/13
Nominal CFM/AHRI Rated CFM [L/s]	2000/1900 [944/897]	2000/1900 [944/897]	2000/1900 [944/897]	2000/1900 [944/897]
AHRI Net Cooling Capacity Btu [kW]	59,000 [17.29]	59,000 [17.29]	59,000 [17.29]	59,000 [17.29]
Net Sensible Capacity Btu [kW]	42,000 [12.31]	42,000 [12.31]	42,000 [12.31]	42,000 [12.31]
Net Latent Capacity Btu [kW]	17,000 [4.98]	17,000 [4.98]	17,000 [4.98]	17,000 [4.98]
Net System Power kW	5.32	5.32	5.32	5.32
<b>Compressor</b>				
No./Type	1/Scroll	1/Scroll	1/Scroll	1/Scroll
<b>Outdoor Sound Rating (dB)<sup>3</sup></b>	83	83	83	83
<b>Outdoor Coil - Fin Type</b>	Louvered	Louvered	Louvered	Louvered
Tube Type	Rifled	Rifled	Rifled	Rifled
Tube Size in. [mm] OD	0.375 [9.5]	0.375 [9.5]	0.375 [9.5]	0.375 [9.5]
Face Area sq. ft. [sq. m]	16.56 [1.54]	16.56 [1.54]	16.56 [1.54]	16.56 [1.54]
Rows / FPI [FPcm]	2 / 22 [9]	2 / 22 [9]	2 / 22 [9]	2 / 22 [9]
<b>Indoor Coil - Fin Type</b>	Corrugated	Corrugated	Corrugated	Corrugated
Tube Type	Rifled	Rifled	Rifled	Rifled
Tube Size in. [mm]	0.375 [9.5]	0.375 [9.5]	0.375 [9.5]	0.375 [9.5]
Face Area sq. ft. [sq. m]	5.17 [0.48]	5.17 [0.48]	5.17 [0.48]	5.17 [0.48]
Rows / FPI [FPcm]	3 / 15 [6]	3 / 15 [6]	3 / 15 [6]	3 / 15 [6]
Refrigerant Control	TX Valves	TX Valves	TX Valves	TX Valves
Drain Connection No./Size in. [mm]	1/0.75 [19.05]	1/0.75 [19.05]	1/0.75 [19.05]	1/0.75 [19.05]
<b>Outdoor Fan - Type</b>	Propeller	Propeller	Propeller	Propeller
No. Used/Diameter in. [mm]	1/24 [609.6]	1/24 [609.6]	1/24 [609.6]	1/24 [609.6]
Drive Type/No. Speeds	Direct/1	Direct/1	Direct/1	Direct/1
CFM [L/s]	3930 [1855]	3930 [1855]	3930 [1855]	3930 [1855]
No. Motors/HP	1 at 1/3 HP	1 at 1/3 HP	1 at 1/3 HP	1 at 1/3 HP
Motor RPM	1075	1075	1075	1075
<b>Indoor Fan - Type</b>	FC Centrifugal	FC Centrifugal	FC Centrifugal	FC Centrifugal
No. Used/Diameter in. [mm]	1/10x10 [254x254]	1/10x10 [254x254]	1/10x10 [254x254]	1/10x10 [254x254]
Drive Type/No. Speeds	Direct/3	Belt/Variable	Belt/Variable	Direct/3
No. Motors	1	1	1	1
Motor HP	1	3/4	1	1
Motor RPM	1075	1725	1725	1075
Motor Frame Size	48	56	56	48
<b>Filter - Type</b>	Disposable	Disposable	Disposable	Disposable
Furnished	Yes	Yes	Yes	Yes
(NO.) Size Recommended in. [mm x mm x mm]	(1)1x16x25 [25x406x635] (1)1x16x25 [25x406x635]	(1)1x16x25 [25x406x635] (1)1x16x25 [25x406x635]	(1)1x16x25 [25x406x635] (1)1x16x25 [25x406x635]	(1)1x16x25 [25x406x635] (1)1x16x25 [25x406x635]
<b>Refrigerant Charge Oz. [g]</b>	160 [4536]	160 [4536]	160 [4536]	160 [4536]
<b>Weights</b>				
Net Weight lbs. [kg]	590 [268]	590 [268]	590 [268]	590 [268]
Ship Weight lbs. [kg]	597 [271]	597 [271]	597 [271]	597 [271]

See Page 24 for Notes.

[ ] Designates Metric Conversions



## NOMINAL SIZES 3-5 TONS [10.6-17.6 kW]

Model RLNL- Series	A060YL	A060YM
<b>Cooling Performance<sup>1</sup></b>		
Gross Cooling Capacity Btu [kW]	61,000 [17.87]	61,000 [17.87]
EER/SEER <sup>2</sup>	11.1/13	11.1/13
Nominal CFM/AHRI Rated CFM [L/s]	2000/1900 [944/897]	2000/1900 [944/897]
AHRI Net Cooling Capacity Btu [kW]	59,000 [17.29]	59,000 [17.29]
Net Sensible Capacity Btu [kW]	42,000 [12.31]	42,000 [12.31]
Net Latent Capacity Btu [kW]	17,000 [4.98]	17,000 [4.98]
Net System Power kW	5.32	5.32
<b>Compressor</b>		
No./Type	1/Scroll	1/Scroll
<b>Outdoor Sound Rating (dB)<sup>3</sup></b>		
	83	83
<b>Outdoor Coil - Fin Type</b>		
	Louvered	Louvered
Tube Type	Rifled	Rifled
Tube Size in. [mm] OD	0.375 [9.5]	0.375 [9.5]
Face Area sq. ft. [sq. m]	16.56 [1.54]	16.56 [1.54]
Rows / FPI [FPcm]	2 / 22 [9]	2 / 22 [9]
<b>Indoor Coil - Fin Type</b>		
	Corrugated	Corrugated
Tube Type	Rifled	Rifled
Tube Size in. [mm]	0.375 [9.5]	0.375 [9.5]
Face Area sq. ft. [sq. m]	5.17 [0.48]	5.17 [0.48]
Rows / FPI [FPcm]	3 / 15 [6]	3 / 15 [6]
Refrigerant Control	TX Valves	TX Valves
Drain Connection No./Size in. [mm]	1/0.75 [19.05]	1/0.75 [19.05]
<b>Outdoor Fan - Type</b>		
	Propeller	Propeller
No. Used/Diameter in. [mm]	1/24 [609.6]	1/24 [609.6]
Drive Type/No. Speeds	Direct/1	Direct/1
CFM [L/s]	3930 [1855]	3930 [1855]
No. Motors/HP	1 at 1/3 HP	1 at 1/3 HP
Motor RPM	1075	1075
<b>Indoor Fan - Type</b>		
	FC Centrifugal	FC Centrifugal
No. Used/Diameter in. [mm]	1/10x10 [254x254]	1/10x10 [254x254]
Drive Type/No. Speeds	Belt/Variable	Belt/Variable
No. Motors	1	1
Motor HP	3/4	1
Motor RPM	1725	1725
Motor Frame Size	56	56
<b>Filter - Type</b>		
	Disposable	Disposable
Furnished	Yes	Yes
(NO.) Size Recommended in. [mm x mm x mm]	(1)1x16x25 [25x406x635] (1)1x16x25 [25x406x635]	(1)1x16x25 [25x406x635] (1)1x16x25 [25x406x635]
<b>Refrigerant Charge Oz. [g]</b>		
	160 [4536]	160 [4536]
<b>Weights</b>		
Net Weight lbs. [kg]	590 [268]	590 [268]
Ship Weight lbs. [kg]	597 [271]	597 [271]

See Page 24 for Notes.

[ ] Designates Metric Conversions



**NOMINAL SIZES 3-5 TONS [10.6-17.6 kW]**

Model RLPL- Series	A036CK	A036CL	A036CM	A036DK
<b>Cooling Performance<sup>1</sup></b>				<b>CONTINUED</b> →
Gross Cooling Capacity Btu [kW]	36,600 [10.72]	36,600 [10.72]	36,600 [10.72]	36,600 [10.72]
EER/SEER <sup>2</sup>	12.05/14	12.05/14	12.05/14	12.05/14
Nominal CFM/AHRI Rated CFM [L/s]	1200/1200 [566/566]	1200/1200 [566/566]	1200/1200 [566/566]	1200/1200 [566/566]
AHRI Net Cooling Capacity Btu [kW]	35,800 [10.49]	35,800 [10.49]	35,800 [10.49]	35,800 [10.49]
Net Sensible Capacity Btu [kW]	27,000 [7.91]	27,000 [7.91]	27,000 [7.91]	27,000 [7.91]
Net Latent Capacity Btu [kW]	8,800 [2.58]	8,800 [2.58]	8,800 [2.58]	8,800 [2.58]
Net System Power kW	2.97	2.97	2.97	2.97
<b>Compressor</b>				
No./Type	1/Scroll	1/Scroll	1/Scroll	1/Scroll
<b>Outdoor Sound Rating (dB)<sup>3</sup></b>	78	78	78	78
<b>Outdoor Coil - Fin Type</b>	Louvered	Louvered	Louvered	Louvered
Tube Type	Rifled	Rifled	Rifled	Rifled
Tube Size in. [mm] OD	0.375 [9.5]	0.375 [9.5]	0.375 [9.5]	0.375 [9.5]
Face Area sq. ft. [sq. m]	16.91 [1.57]	16.91 [1.57]	16.91 [1.57]	16.91 [1.57]
Rows / FPI [FPcm]	1 / 22 [9]	1 / 22 [9]	1 / 22 [9]	1 / 22 [9]
<b>Indoor Coil - Fin Type</b>	Corrugated	Corrugated	Corrugated	Corrugated
Tube Type	Rifled	Rifled	Rifled	Rifled
Tube Size in. [mm]	0.375 [9.5]	0.375 [9.5]	0.375 [9.5]	0.375 [9.5]
Face Area sq. ft. [sq. m]	5.17 [0.48]	5.17 [0.48]	5.17 [0.48]	5.17 [0.48]
Rows / FPI [FPcm]	2 / 17 [7]	2 / 17 [7]	2 / 17 [7]	2 / 17 [7]
Refrigerant Control	TX Valves	TX Valves	TX Valves	TX Valves
Drain Connection No./Size in. [mm]	1/0.75 [19.05]	1/0.75 [19.05]	1/0.75 [19.05]	1/0.75 [19.05]
<b>Outdoor Fan - Type</b>	Propeller	Propeller	Propeller	Propeller
No. Used/Diameter in. [mm]	1/24 [609.6]	1/24 [609.6]	1/24 [609.6]	1/24 [609.6]
Drive Type/No. Speeds	Direct/1	Direct/1	Direct/1	Direct/1
CFM [L/s]	3680 [1737]	3680 [1737]	3680 [1737]	3680 [1737]
No. Motors/HP	1 at 1/3 HP	1 at 1/3 HP	1 at 1/3 HP	1 at 1/3 HP
Motor RPM	1075	1075	1075	1075
<b>Indoor Fan - Type</b>	FC Centrifugal	FC Centrifugal	FC Centrifugal	FC Centrifugal
No. Used/Diameter in. [mm]	1/10x10 [254x254]	1/10x10 [254x254]	1/10x10 [254x254]	1/10x10 [254x254]
Drive Type/No. Speeds	Direct/4	Belt/Variable	Belt/Variable	Direct/4
No. Motors	1	1	1	1
Motor HP	1/2	1/2	3/4	1/2
Motor RPM	1075	1725	1725	1075
Motor Frame Size	48	48	56	48
<b>Filter - Type</b>	Disposable	Disposable	Disposable	Disposable
Furnished	Yes	Yes	Yes	Yes
(NO.) Size Recommended in. [mm x mm x mm]	(1)1x16x25 [25x406x635] (1)1x16x25 [25x406x635]	(1)1x16x25 [25x406x635] (1)1x16x25 [25x406x635]	(1)1x16x25 [25x406x635] (1)1x16x25 [25x406x635]	(1)1x16x25 [25x406x635] (1)1x16x25 [25x406x635]
<b>Refrigerant Charge Oz. [g]</b>	96 [2722]	96 [2722]	96 [2722]	96 [2722]
<b>Weights</b>				
Net Weight lbs. [kg]	543 [246]	543 [246]	543 [246]	543 [246]
Ship Weight lbs. [kg]	550 [249]	550 [249]	550 [249]	550 [249]

See Page 24 for Notes.

[ ] Designates Metric Conversions



## NOMINAL SIZES 3-5 TONS [10.6-17.6 kW]

Model RLPL- Series	A036DL	A036DM	A036JK	A042CK
<b>Cooling Performance<sup>1</sup></b>				<b>CONTINUED</b> →
Gross Cooling Capacity Btu [kW]	36,600 [10.72]	36,600 [10.72]	36,600 [10.72]	43,000 [12.6]
EER/SEER <sup>2</sup>	12.05/14	12.05/14	12.05/14	11.85/14
Nominal CFM/AHRI Rated CFM [L/s]	1200/1200 [566/566]	1200/1200 [566/566]	1200/1200 [566/566]	1400/1450 [661/684]
AHRI Net Cooling Capacity Btu [kW]	35,800 [10.49]	35,800 [10.49]	35,800 [10.49]	41,500 [12.16]
Net Sensible Capacity Btu [kW]	27,000 [7.91]	27,000 [7.91]	27,000 [7.91]	31,200 [9.14]
Net Latent Capacity Btu [kW]	8,800 [2.58]	8,800 [2.58]	8,800 [2.58]	10,300 [3.02]
Net System Power kW	2.97	2.97	2.97	3.5
<b>Compressor</b>				
No./Type	1/Scroll	1/Scroll	1/Scroll	1/Scroll
<b>Outdoor Sound Rating (dB)<sup>3</sup></b>	78	78	78	78
<b>Outdoor Coil - Fin Type</b>	Louvered	Louvered	Louvered	Louvered
Tube Type	Rifled	Rifled	Rifled	Rifled
Tube Size in. [mm] OD	0.375 [9.5]	0.375 [9.5]	0.375 [9.5]	0.375 [9.5]
Face Area sq. ft. [sq. m]	16.91 [1.57]	16.91 [1.57]	16.91 [1.57]	16.91 [1.57]
Rows / FPI [FPcm]	1 / 22 [9]	1 / 22 [9]	1 / 22 [9]	1.53 / 22 [9]
<b>Indoor Coil - Fin Type</b>	Corrugated	Corrugated	Corrugated	Corrugated
Tube Type	Rifled	Rifled	Rifled	Rifled
Tube Size in. [mm]	0.375 [9.5]	0.375 [9.5]	0.375 [9.5]	0.375 [9.5]
Face Area sq. ft. [sq. m]	5.17 [0.48]	5.17 [0.48]	5.17 [0.48]	5.17 [0.48]
Rows / FPI [FPcm]	2 / 17 [7]	2 / 17 [7]	2 / 17 [7]	3 / 13 [5]
Refrigerant Control	TX Valves	TX Valves	TX Valves	TX Valves
Drain Connection No./Size in. [mm]	1/0.75 [19.05]	1/0.75 [19.05]	1/0.75 [19.05]	1/0.75 [19.05]
<b>Outdoor Fan - Type</b>	Propeller	Propeller	Propeller	Propeller
No. Used/Diameter in. [mm]	1/24 [609.6]	1/24 [609.6]	1/24 [609.6]	1/24 [609.6]
Drive Type/No. Speeds	Direct/1	Direct/1	Direct/1	Direct/1
CFM [L/s]	3680 [1737]	3680 [1737]	3680 [1737]	3680 [1737]
No. Motors/HP	1 at 1/3 HP	1 at 1/3 HP	1 at 1/3 HP	1 at 1/3 HP
Motor RPM	1075	1075	1075	1075
<b>Indoor Fan - Type</b>	FC Centrifugal	FC Centrifugal	FC Centrifugal	FC Centrifugal
No. Used/Diameter in. [mm]	1/10x10 [254x254]	1/10x10 [254x254]	1/10x10 [254x254]	1/10x10 [254x254]
Drive Type/No. Speeds	Belt/Variable	Belt/Variable	Direct/4	Direct/4
No. Motors	1	1	1	1
Motor HP	1/2	3/4	1/2	3/4
Motor RPM	1725	1725	1075	1075
Motor Frame Size	48	56	48	48
<b>Filter - Type</b>	Disposable	Disposable	Disposable	Disposable
Furnished	Yes	Yes	Yes	Yes
(NO.) Size Recommended in. [mm x mm x mm]	(1)1x16x25 [25x406x635] (1)1x16x25 [25x406x635]	(1)1x16x25 [25x406x635] (1)1x16x25 [25x406x635]	(1)1x16x25 [25x406x635] (1)1x16x25 [25x406x635]	(1)1x16x25 [25x406x635] (1)1x16x25 [25x406x635]
<b>Refrigerant Charge Oz. [g]</b>	96 [2722]	96 [2722]	96 [2722]	125 [3544]
<b>Weights</b>				
Net Weight lbs. [kg]	543 [246]	543 [246]	543 [246]	570 [259]
Ship Weight lbs. [kg]	550 [249]	550 [249]	550 [249]	577 [262]

See Page 24 for Notes.

[ ] Designates Metric Conversions



## NOMINAL SIZES 3-5 TONS [10.6-17.6 kW]

Model RLPL- Series	A042CL	A042CM	A042DK	A042DL
<b>Cooling Performance<sup>1</sup></b>				
	<b>CONTINUED →</b>			
Gross Cooling Capacity Btu [kW]	43,000 [12.6]	43,000 [12.6]	43,000 [12.6]	43,000 [12.6]
EER/SEER <sup>2</sup>	11.85/14	11.85/14	11.85/14	11.85/14
Nominal CFM/AHRI Rated CFM [L/s]	1400/1450 [661/684]	1400/1450 [661/684]	1400/1450 [661/684]	1400/1450 [661/684]
AHRI Net Cooling Capacity Btu [kW]	41,500 [12.16]	41,500 [12.16]	41,500 [12.16]	41,500 [12.16]
Net Sensible Capacity Btu [kW]	31,200 [9.14]	31,200 [9.14]	31,200 [9.14]	31,200 [9.14]
Net Latent Capacity Btu [kW]	10,300 [3.02]	10,300 [3.02]	10,300 [3.02]	10,300 [3.02]
Net System Power kW	3.5	3.5	3.5	3.5
<b>Compressor</b>				
No./Type	1/Scroll	1/Scroll	1/Scroll	1/Scroll
<b>Outdoor Sound Rating (dB)<sup>3</sup></b>				
	78	78	78	78
<b>Outdoor Coil - Fin Type</b>				
	Louvered	Louvered	Louvered	Louvered
Tube Type	Rifled	Rifled	Rifled	Rifled
Tube Size in. [mm] OD	0.375 [9.5]	0.375 [9.5]	0.375 [9.5]	0.375 [9.5]
Face Area sq. ft. [sq. m]	16.91 [1.57]	16.91 [1.57]	16.91 [1.57]	16.91 [1.57]
Rows / FPI [FPcm]	1.53 / 22 [9]	1.53 / 22 [9]	1.53 / 22 [9]	1.53 / 22 [9]
<b>Indoor Coil - Fin Type</b>				
	Corrugated	Corrugated	Corrugated	Corrugated
Tube Type	Rifled	Rifled	Rifled	Rifled
Tube Size in. [mm]	0.375 [9.5]	0.375 [9.5]	0.375 [9.5]	0.375 [9.5]
Face Area sq. ft. [sq. m]	5.17 [0.48]	5.17 [0.48]	5.17 [0.48]	5.17 [0.48]
Rows / FPI [FPcm]	3 / 13 [5]	3 / 13 [5]	3 / 13 [5]	3 / 13 [5]
Refrigerant Control	TX Valves	TX Valves	TX Valves	TX Valves
Drain Connection No./Size in. [mm]	1/0.75 [19.05]	1/0.75 [19.05]	1/0.75 [19.05]	1/0.75 [19.05]
<b>Outdoor Fan - Type</b>				
	Propeller	Propeller	Propeller	Propeller
No. Used/Diameter in. [mm]	1/24 [609.6]	1/24 [609.6]	1/24 [609.6]	1/24 [609.6]
Drive Type/No. Speeds	Direct/1	Direct/1	Direct/1	Direct/1
CFM [L/s]	3680 [1737]	3680 [1737]	3680 [1737]	3680 [1737]
No. Motors/HP	1 at 1/3 HP	1 at 1/3 HP	1 at 1/3 HP	1 at 1/3 HP
Motor RPM	1075	1075	1075	1075
<b>Indoor Fan - Type</b>				
	FC Centrifugal	FC Centrifugal	FC Centrifugal	FC Centrifugal
No. Used/Diameter in. [mm]	1/10x10 [254x254]	1/10x10 [254x254]	1/10x10 [254x254]	1/10x10 [254x254]
Drive Type/No. Speeds	Belt/Variable	Belt/Variable	Direct/4	Belt/Variable
No. Motors	1	1	1	1
Motor HP	1/2	3/4	3/4	1/2
Motor RPM	1725	1725	1075	1725
Motor Frame Size	48	56	48	48
<b>Filter - Type</b>				
	Disposable	Disposable	Disposable	Disposable
Furnished	Yes	Yes	Yes	Yes
(NO.) Size Recommended in. [mm x mm x mm]	(1)1x16x25 [25x406x635]	(1)1x16x25 [25x406x635]	(1)1x16x25 [25x406x635]	(1)1x16x25 [25x406x635]
	(1)1x16x25 [25x406x635]	(1)1x16x25 [25x406x635]	(1)1x16x25 [25x406x635]	(1)1x16x25 [25x406x635]
<b>Refrigerant Charge Oz. [g]</b>				
	125 [3544]	125 [3544]	125 [3544]	125 [3544]
<b>Weights</b>				
Net Weight lbs. [kg]	570 [259]	570 [259]	570 [259]	570 [259]
Ship Weight lbs. [kg]	577 [262]	577 [262]	577 [262]	577 [262]

See Page 24 for Notes.

[ ] Designates Metric Conversions



## NOMINAL SIZES 3-5 TONS [10.6-17.6 kW]

Model RLPL- Series	A042DM	A042JK	A048CK	A048CL
<b>Cooling Performance<sup>1</sup></b>				<b>CONTINUED</b> →
Gross Cooling Capacity Btu [kW]	43,000 [12.6]	43,000 [12.6]	50,500 [14.8]	50,500 [14.8]
EER/SEER <sup>2</sup>	11.85/14	11.85/14	12.15/14	12.15/14
Nominal CFM/AHRI Rated CFM [L/s]	1400/1450 [661/684]	1400/1450 [661/684]	1600/1600 [755/755]	1600/1600 [755/755]
AHRI Net Cooling Capacity Btu [kW]	41,500 [12.16]	41,500 [12.16]	49,000 [14.36]	49,000 [14.36]
Net Sensible Capacity Btu [kW]	31,200 [9.14]	31,200 [9.14]	36,400 [10.67]	36,400 [10.67]
Net Latent Capacity Btu [kW]	10,300 [3.02]	10,300 [3.02]	12,600 [3.69]	12,600 [3.69]
Net System Power kW	3.5	3.5	4.03	4.03
<b>Compressor</b>				
No./Type	1/Scroll	1/Scroll	1/Scroll	1/Scroll
<b>Outdoor Sound Rating (dB)<sup>3</sup></b>	78	78	78	78
<b>Outdoor Coil - Fin Type</b>	Louvered	Louvered	Louvered	Louvered
Tube Type	Rifled	Rifled	Rifled	Rifled
Tube Size in. [mm] OD	0.375 [9.5]	0.375 [9.5]	0.375 [9.5]	0.375 [9.5]
Face Area sq. ft. [sq. m]	16.91 [1.57]	16.91 [1.57]	16.56 [1.54]	16.56 [1.54]
Rows / FPI [FPcm]	1.53 / 22 [9]	1.53 / 22 [9]	2 / 22 [9]	2 / 22 [9]
<b>Indoor Coil - Fin Type</b>	Corrugated	Corrugated	Corrugated	Corrugated
Tube Type	Rifled	Rifled	Rifled	Rifled
Tube Size in. [mm]	0.375 [9.5]	0.375 [9.5]	0.375 [9.5]	0.375 [9.5]
Face Area sq. ft. [sq. m]	5.17 [0.48]	5.17 [0.48]	5.17 [0.48]	5.17 [0.48]
Rows / FPI [FPcm]	3 / 13 [5]	3 / 13 [5]	3 / 15 [6]	3 / 15 [6]
Refrigerant Control	TX Valves	TX Valves	TX Valves	TX Valves
Drain Connection No./Size in. [mm]	1/0.75 [19.05]	1/0.75 [19.05]	1/0.75 [19.05]	1/0.75 [19.05]
<b>Outdoor Fan - Type</b>	Propeller	Propeller	Propeller	Propeller
No. Used/Diameter in. [mm]	1/24 [609.6]	1/24 [609.6]	1/24 [609.6]	1/24 [609.6]
Drive Type/No. Speeds	Direct/1	Direct/1	Direct/1	Direct/1
CFM [L/s]	3680 [1737]	3680 [1737]	3680 [1737]	3680 [1737]
No. Motors/HP	1 at 1/3 HP	1 at 1/3 HP	1 at 1/3 HP	1 at 1/3 HP
Motor RPM	1075	1075	1075	1075
<b>Indoor Fan - Type</b>	FC Centrifugal	FC Centrifugal	FC Centrifugal	FC Centrifugal
No. Used/Diameter in. [mm]	1/10x10 [254x254]	1/10x10 [254x254]	1/10x10 [254x254]	1/10x10 [254x254]
Drive Type/No. Speeds	Belt/Variable	Direct/4	Direct/4	Belt/Variable
No. Motors	1	1	1	1
Motor HP	3/4	3/4	3/4	1/2
Motor RPM	1725	1075	1075	1725
Motor Frame Size	56	48	48	48
<b>Filter - Type</b>	Disposable	Disposable	Disposable	Disposable
Furnished	Yes	Yes	Yes	Yes
(NO.) Size Recommended in. [mm x mm x mm]	(1)1x16x25 [25x406x635] (1)1x16x25 [25x406x635]	(1)1x16x25 [25x406x635] (1)1x16x25 [25x406x635]	(1)1x16x25 [25x406x635] (1)1x16x25 [25x406x635]	(1)1x16x25 [25x406x635] (1)1x16x25 [25x406x635]
<b>Refrigerant Charge Oz. [g]</b>	125 [3544]	125 [3544]	165 [4678]	165 [4678]
<b>Weights</b>				
Net Weight lbs. [kg]	570 [259]	570 [259]	580 [263]	580 [263]
Ship Weight lbs. [kg]	577 [262]	577 [262]	587 [266]	587 [266]

See Page 24 for Notes.

[ ] Designates Metric Conversions



**NOMINAL SIZES 3-5 TONS [10.6-17.6 kW]**

Model RLPL- Series	A048CM	A048DK	A048DL	A048DM
<b>Cooling Performance<sup>1</sup></b>				
Gross Cooling Capacity Btu [kW]	50,500 [14.8]	50,500 [14.8]	50,500 [14.8]	50,500 [14.8]
EER/SEER <sup>2</sup>	12.15/14	12.15/14	12.15/14	12.15/14
Nominal CFM/AHRI Rated CFM [L/s]	1600/1600 [755/755]	1600/1600 [755/755]	1600/1600 [755/755]	1600/1600 [755/755]
AHRI Net Cooling Capacity Btu [kW]	49,000 [14.36]	49,000 [14.36]	49,000 [14.36]	49,000 [14.36]
Net Sensible Capacity Btu [kW]	36,400 [10.67]	36,400 [10.67]	36,400 [10.67]	36,400 [10.67]
Net Latent Capacity Btu [kW]	12,600 [3.69]	12,600 [3.69]	12,600 [3.69]	12,600 [3.69]
Net System Power kW	4.03	4.03	4.03	4.03
<b>Compressor</b>				
No./Type	1/Scroll	1/Scroll	1/Scroll	1/Scroll
<b>Outdoor Sound Rating (dB)<sup>3</sup></b>				
	78	78	78	78
<b>Outdoor Coil - Fin Type</b>				
Tube Type	Rifled	Rifled	Rifled	Rifled
Tube Size in. [mm] OD	0.375 [9.5]	0.375 [9.5]	0.375 [9.5]	0.375 [9.5]
Face Area sq. ft. [sq. m]	16.56 [1.54]	16.56 [1.54]	16.56 [1.54]	16.56 [1.54]
Rows / FPI [FPcm]	2 / 22 [9]	2 / 22 [9]	2 / 22 [9]	2 / 22 [9]
<b>Indoor Coil - Fin Type</b>				
Tube Type	Corrugated	Corrugated	Corrugated	Corrugated
Tube Size in. [mm]	0.375 [9.5]	0.375 [9.5]	0.375 [9.5]	0.375 [9.5]
Face Area sq. ft. [sq. m]	5.17 [0.48]	5.17 [0.48]	5.17 [0.48]	5.17 [0.48]
Rows / FPI [FPcm]	3 / 15 [6]	3 / 15 [6]	3 / 15 [6]	3 / 15 [6]
Refrigerant Control	TX Valves	TX Valves	TX Valves	TX Valves
Drain Connection No./Size in. [mm]	1/0.75 [19.05]	1/0.75 [19.05]	1/0.75 [19.05]	1/0.75 [19.05]
<b>Outdoor Fan - Type</b>				
No. Used/Diameter in. [mm]	1/24 [609.6]	1/24 [609.6]	1/24 [609.6]	1/24 [609.6]
Drive Type/No. Speeds	Direct/1	Direct/1	Direct/1	Direct/1
CFM [L/s]	3680 [1737]	3680 [1737]	3680 [1737]	3680 [1737]
No. Motors/HP	1 at 1/3 HP	1 at 1/3 HP	1 at 1/3 HP	1 at 1/3 HP
Motor RPM	1075	1075	1075	1075
<b>Indoor Fan - Type</b>				
No. Used/Diameter in. [mm]	1/10x10 [254x254]	1/10x10 [254x254]	1/10x10 [254x254]	1/10x10 [254x254]
Drive Type/No. Speeds	Belt/Variable	Direct/4	Belt/Variable	Belt/Variable
No. Motors	1	1	1	1
Motor HP	3/4	3/4	1/2	3/4
Motor RPM	1725	1075	1725	1725
Motor Frame Size	56	48	48	56
<b>Filter - Type</b>				
Furnished	Disposable	Disposable	Disposable	Disposable
(NO.) Size Recommended in. [mm x mm x mm]	Yes (1)1x16x25 [25x406x635] (1)1x16x25 [25x406x635]	Yes (1)1x16x25 [25x406x635] (1)1x16x25 [25x406x635]	Yes (1)1x16x25 [25x406x635] (1)1x16x25 [25x406x635]	Yes (1)1x16x25 [25x406x635] (1)1x16x25 [25x406x635]
<b>Refrigerant Charge Oz. [g]</b>				
	165 [4678]	165 [4678]	165 [4678]	165 [4678]
<b>Weights</b>				
Net Weight lbs. [kg]	580 [263]	580 [263]	580 [263]	580 [263]
Ship Weight lbs. [kg]	587 [266]	587 [266]	587 [266]	587 [266]

**CONTINUED** →

See Page 24 for Notes.

[ ] Designates Metric Conversions



## NOMINAL SIZES 3-5 TONS [10.6-17.6 kW]

Model RLPL- Series	A048JK	A060CK	A060CL	A060CM
<b>Cooling Performance<sup>1</sup></b>				
Gross Cooling Capacity Btu [kW]	50,500 [14.8]	61,500 [18.02]	61,500 [18.02]	61,500 [18.02]
EER/SEER <sup>2</sup>	12.15/14	12.25/14	12.25/14	12.25/14
Nominal CFM/AHRI Rated CFM [L/s]	1600/1600 [755/755]	2000/1850 [944/873]	2000/1850 [944/873]	2000/1850 [944/873]
AHRI Net Cooling Capacity Btu [kW]	49,000 [14.36]	60,000 [17.58]	60,000 [17.58]	60,000 [17.58]
Net Sensible Capacity Btu [kW]	36,400 [10.67]	42,500 [12.45]	42,500 [12.45]	42,500 [12.45]
Net Latent Capacity Btu [kW]	12,600 [3.69]	17,500 [5.13]	17,500 [5.13]	17,500 [5.13]
Net System Power kW	4.03	4.9	4.9	4.9
<b>Compressor</b>				
No./Type	1/Scroll	1/Scroll	1/Scroll	1/Scroll
<b>Outdoor Sound Rating (dB)<sup>3</sup></b>				
	78	83	83	83
<b>Outdoor Coil - Fin Type</b>				
Tube Type	Rifled	Rifled	Rifled	Rifled
Tube Size in. [mm] OD	0.375 [9.5]	0.375 [9.5]	0.375 [9.5]	0.375 [9.5]
Face Area sq. ft. [sq. m]	16.56 [1.54]	16.56 [1.54]	16.56 [1.54]	16.56 [1.54]
Rows / FPI [FPcm]	2 / 22 [9]	2 / 22 [9]	2 / 22 [9]	2 / 22 [9]
<b>Indoor Coil - Fin Type</b>				
Tube Type	Corrugated	Corrugated	Corrugated	Corrugated
Tube Size in. [mm]	0.375 [9.5]	0.375 [9.5]	0.375 [9.5]	0.375 [9.5]
Face Area sq. ft. [sq. m]	5.17 [0.48]	5.17 [0.48]	5.17 [0.48]	5.17 [0.48]
Rows / FPI [FPcm]	3 / 15 [6]	3 / 15 [6]	3 / 15 [6]	3 / 15 [6]
Refrigerant Control	TX Valves	TX Valves	TX Valves	TX Valves
Drain Connection No./Size in. [mm]	1/0.75 [19.05]	1/0.75 [19.05]	1/0.75 [19.05]	1/0.75 [19.05]
<b>Outdoor Fan - Type</b>				
No. Used/Diameter in. [mm]	1/24 [609.6]	1/24 [609.6]	1/24 [609.6]	1/24 [609.6]
Drive Type/No. Speeds	Direct/1	Direct/1	Direct/1	Direct/1
CFM [L/s]	3680 [1737]	3930 [1855]	3930 [1855]	3930 [1855]
No. Motors/HP	1 at 1/3 HP	1 at 1/3 HP	1 at 1/3 HP	1 at 1/3 HP
Motor RPM	1075	1075	1075	1075
<b>Indoor Fan - Type</b>				
No. Used/Diameter in. [mm]	1/10x10 [254x254]	1/10x10 [254x254]	1/11x10 [279.4x254]	1/11x10 [279.4x254]
Drive Type/No. Speeds	Direct/4	Direct/3	Belt/Variable	Belt/Variable
No. Motors	1	1	1	1
Motor HP	3/4	1	3/4	1
Motor RPM	1075	1075	1725	1725
Motor Frame Size	48	48	56	56
<b>Filter - Type</b>				
Furnished	Disposable	Disposable	Disposable	Disposable
(NO.) Size Recommended in. [mm x mm x mm]	Yes (1)1x16x25 [25x406x635] (1)1x16x25 [25x406x635]	Yes (1)1x16x25 [25x406x635] (1)1x16x25 [25x406x635]	Yes (1)1x16x25 [25x406x635] (1)1x16x25 [25x406x635]	Yes (1)1x16x25 [25x406x635] (1)1x16x25 [25x406x635]
<b>Refrigerant Charge Oz. [g]</b>				
	165 [4678]	147 [4167]	147 [4167]	147 [4167]
<b>Weights</b>				
Net Weight lbs. [kg]	580 [263]	590 [268]	590 [268]	590 [268]
Ship Weight lbs. [kg]	587 [266]	597 [271]	597 [271]	597 [271]

See Page 24 for Notes.

[ ] Designates Metric Conversions



## NOMINAL SIZES 3-5 TONS [10.6-17.6 kW]

Model RLPL- Series	A060DK	A060DL	A060DM	A060JK
<b>Cooling Performance<sup>1</sup></b>				
Gross Cooling Capacity Btu [kW]	61,500 [18.02]	61,500 [18.02]	61,500 [18.02]	61,500 [18.02]
EER/SEER <sup>2</sup>	12.25/14	12.25/14	12.25/14	12.25/14
Nominal CFM/AHRI Rated CFM [L/s]	2000/1850 [944/873]	2000/1850 [944/873]	2000/1850 [944/873]	2000/1850 [944/873]
AHRI Net Cooling Capacity Btu [kW]	60,000 [17.58]	60,000 [17.58]	60,000 [17.58]	60,000 [17.58]
Net Sensible Capacity Btu [kW]	42,500 [12.45]	42,500 [12.45]	42,500 [12.45]	42,500 [12.45]
Net Latent Capacity Btu [kW]	17,500 [5.13]	17,500 [5.13]	17,500 [5.13]	17,500 [5.13]
Net System Power kW	4.9	4.9	4.9	4.9
<b>Compressor</b>				
No./Type	1/Scroll	1/Scroll	1/Scroll	1/Scroll
<b>Outdoor Sound Rating (dB)<sup>3</sup></b>				
	83	83	83	83
<b>Outdoor Coil - Fin Type</b>				
Tube Type	Louvered	Louvered	Louvered	Louvered
Tube Type	Rifled	Rifled	Rifled	Rifled
Tube Size in. [mm] OD	0.375 [9.5]	0.375 [9.5]	0.375 [9.5]	0.375 [9.5]
Face Area sq. ft. [sq. m]	16.56 [1.54]	16.56 [1.54]	16.56 [1.54]	16.56 [1.54]
Rows / FPI [FPcm]	2 / 22 [9]	2 / 22 [9]	2 / 22 [9]	2 / 22 [9]
<b>Indoor Coil - Fin Type</b>				
Tube Type	Corrugated	Corrugated	Corrugated	Corrugated
Tube Type	Rifled	Rifled	Rifled	Rifled
Tube Size in. [mm]	0.375 [9.5]	0.375 [9.5]	0.375 [9.5]	0.375 [9.5]
Face Area sq. ft. [sq. m]	5.17 [0.48]	5.17 [0.48]	5.17 [0.48]	5.17 [0.48]
Rows / FPI [FPcm]	3 / 15 [6]	3 / 15 [6]	3 / 15 [6]	3 / 15 [6]
Refrigerant Control	TX Valves	TX Valves	TX Valves	TX Valves
Drain Connection No./Size in. [mm]	1/0.75 [19.05]	1/0.75 [19.05]	1/0.75 [19.05]	1/0.75 [19.05]
<b>Outdoor Fan - Type</b>				
	Propeller	Propeller	Propeller	Propeller
No. Used/Diameter in. [mm]	1/24 [609.6]	1/24 [609.6]	1/24 [609.6]	1/24 [609.6]
Drive Type/No. Speeds	Direct/1	Direct/1	Direct/1	Direct/1
CFM [L/s]	3930 [1855]	3930 [1855]	3930 [1855]	3930 [1855]
No. Motors/HP	1 at 1/3 HP	1 at 1/3 HP	1 at 1/3 HP	1 at 1/3 HP
Motor RPM	1075	1075	1075	1075
<b>Indoor Fan - Type</b>				
	FC Centrifugal	FC Centrifugal	FC Centrifugal	FC Centrifugal
No. Used/Diameter in. [mm]	1/10x10 [254x254]	1/11x10 [279.4x254]	1/11x10 [279.4x254]	1/10x10 [254x254]
Drive Type/No. Speeds	Direct/3	Belt/Variable	Belt/Variable	Direct/3
No. Motors	1	1	1	1
Motor HP	1	3/4	1	1
Motor RPM	1075	1725	1725	1075
Motor Frame Size	48	56	56	48
<b>Filter - Type</b>				
	Disposable	Disposable	Disposable	Disposable
Furnished	Yes	Yes	Yes	Yes
(NO.) Size Recommended in. [mm x mm x mm]	(1)1x16x25 [25x406x635]	(1)1x16x25 [25x406x635]	(1)1x16x25 [25x406x635]	(1)1x16x25 [25x406x635]
	(1)1x16x25 [25x406x635]	(1)1x16x25 [25x406x635]	(1)1x16x25 [25x406x635]	(1)1x16x25 [25x406x635]
<b>Refrigerant Charge Oz. [g]</b>				
	147 [4167]	147 [4167]	147 [4167]	147 [4167]
<b>Weights</b>				
Net Weight lbs. [kg]	590 [268]	590 [268]	590 [268]	590 [268]
Ship Weight lbs. [kg]	597 [271]	597 [271]	597 [271]	597 [271]

See Page 24 for Notes.

[ ] Designates Metric Conversions



## NOTES:

1. Cooling Performance is rated at 95° F ambient, 80° F entering dry bulb, 67° F entering wet bulb. Gross capacity does not include the effect of fan motor heat. AHRI capacity is net and includes the effect of fan motor heat. Units are suitable for operation to  $\pm 20\%$  of nominal CFM. Units are certified in accordance with the Unitary Air Conditioner Equipment certification program, which is based on AHRI Standard 210/240 or 360.
2. EER and/or SEER are rated at AHRI conditions and in accordance with DOE test procedures.
3. Outdoor Sound Rating shown is tested in accordance with AHRI Standard 270.



# SYSTEMS PERFORMANCE—RLNL- SERIES

## GROSS SYSTEMS PERFORMANCE DATA—RLNL-A036

		ENTERING INDOOR AIR @ 80°F [26.7°C] dbE ①									
wbE		71°F [21.7°C]			67°F [19.4°C]			63°F [17.2°C]			
CFM [L/s]		1500 [708]	1200 [566]	900 [425]	1500 [708]	1200 [566]	900 [425]	1500 [708]	1200 [566]	900 [425]	
DR ①		.19	.15	.11	.19	.15	.11	.19	.15	.11	
OUTDOOR DRY BULB TEMPERATURE °F [°C]	75 [23.9]	Total BTUH [kW] Sens BTUH [kW] Power	46.6 [13.66] 28.3 [8.29] 2.1	44.6 [13.07] 25.3 [7.41] 2.1	42.5 [12.46] 22.4 [6.56] 2.0	43.2 [12.66] 33.4 [9.79] 2.2	41.4 [12.13] 29.9 [8.76] 2.1	39.5 [11.58] 26.4 [7.74] 2.1	40.2 [11.78] 38.6 [11.31] 2.2	38.4 [11.25] 34.6 [10.14] 2.1	36.7 [10.76] 30.5 [8.94] 2.1
	80 [26.7]	Total BTUH [kW] Sens BTUH [kW] Power	45.4 [13.31] 27.7 [8.12] 2.3	43.5 [12.75] 24.8 [7.27] 2.2	41.5 [12.16] 21.9 [6.42] 2.2	42.1 [12.34] 32.8 [9.61] 2.3	40.3 [11.81] 29.4 [8.62] 2.3	38.4 [11.25] 25.9 [7.59] 2.2	39.0 [11.43] 38.0 [11.14] 2.3	37.3 [10.93] 34.0 [9.96] 2.3	35.6 [10.43] 30.1 [8.82] 2.2
	85 [29.4]	Total BTUH [kW] Sens BTUH [kW] Power	44.3 [12.98] 27.1 [7.94] 2.4	42.3 [12.40] 24.2 [7.09] 2.4	40.4 [11.84] 21.4 [6.27] 2.3	40.9 [11.99] 32.2 [9.44] 2.4	39.2 [11.49] 28.8 [8.44] 2.4	37.4 [10.96] 25.4 [7.44] 2.4	37.9 [11.11] 37.4 [10.96] 2.5	36.2 [10.61] 33.5 [9.82] 2.4	34.6 [10.14] 29.6 [8.67] 2.4
	90 [32.2]	Total BTUH [kW] Sens BTUH [kW] Power	43.1 [12.63] 26.4 [7.74] 2.5	41.2 [12.07] 23.7 [6.95] 2.5	39.3 [11.52] 20.9 [6.13] 2.4	39.8 [11.66] 31.5 [9.23] 2.6	38.0 [11.14] 28.2 [8.26] 2.5	36.3 [10.64] 25.0 [7.33] 2.5	36.7 [10.76] 36.7 [10.76] 2.6	35.1 [10.29] 32.9 [9.64] 2.5	33.5 [9.82] 29.1 [8.53] 2.5
	95 [35]	Total BTUH [kW] Sens BTUH [kW] Power	41.9 [12.28] 25.8 [7.56] 2.7	40.1 [11.75] 23.1 [6.77] 2.6	38.3 [11.22] 20.4 [5.98] 2.6	38.6 [11.31] 30.9 [9.06] 2.7	36.9 [10.81] 27.7 [8.12] 2.7	35.2 [10.32] 24.5 [7.18] 2.6	35.5 [10.40] 35.5 [10.40] 2.7	33.9 [9.94] 32.4 [9.50] 2.7	32.4 [9.50] 28.6 [8.38] 2.6
	100 [37.8]	Total BTUH [kW] Sens BTUH [kW] Power	40.7 [11.93] 25.2 [7.39] 2.8	38.9 [11.40] 22.5 [6.59] 2.8	37.1 [10.87] 19.9 [5.83] 2.7	37.3 [10.93] 30.3 [8.88] 2.9	35.7 [10.46] 27.1 [7.94] 2.8	34.1 [9.99] 23.9 [7.00] 2.7	34.3 [10.05] 34.3 [10.05] 2.9	32.8 [9.61] 31.8 [9.32] 2.8	31.3 [9.17] 28.1 [8.24] 2.8
	105 [40.6]	Total BTUH [kW] Sens BTUH [kW] Power	39.4 [11.55] 24.5 [7.18] 3.0	37.7 [11.05] 21.9 [6.42] 2.9	36.0 [10.55] 19.4 [5.69] 2.8	36.1 [10.58] 29.6 [8.67] 3.0	34.5 [10.11] 26.5 [7.77] 2.9	32.9 [9.64] 23.4 [6.86] 2.9	33.0 [9.67] 33.0 [9.67] 3.0	31.6 [9.26] 31.2 [9.14] 2.9	30.1 [8.82] 27.5 [8.06] 2.9
	110 [43.3]	Total BTUH [kW] Sens BTUH [kW] Power	38.1 [11.17] 23.7 [6.95] 3.1	36.5 [10.70] 21.3 [6.24] 3.0	34.8 [10.20] 18.8 [5.51] 3.0	34.8 [10.20] 28.8 [8.44] 3.1	33.3 [9.76] 25.8 [7.56] 3.1	31.8 [9.32] 22.8 [6.68] 3.0	31.7 [9.29] 31.7 [9.29] 3.1	30.3 [8.88] 30.3 [8.88] 3.1	29.0 [8.50] 26.9 [7.88] 3.0
	115 [46.1]	Total BTUH [kW] Sens BTUH [kW] Power	36.8 [10.79] 23.0 [6.74] 3.2	35.2 [10.32] 20.6 [6.04] 3.2	33.6 [9.85] 18.2 [5.33] 3.1	33.5 [9.82] 28.1 [8.24] 3.3	32.0 [9.38] 25.1 [7.36] 3.2	30.6 [8.97] 22.2 [6.51] 3.1	30.4 [8.91] 30.4 [8.91] 3.3	29.1 [8.53] 29.1 [8.53] 3.2	27.7 [8.12] 26.3 [7.71] 3.1

## GROSS SYSTEMS PERFORMANCE DATA—RLNL-A042

		ENTERING INDOOR AIR @ 80°F [26.7°C] dbE ①									
wbE		71°F [21.7°C]			67°F [19.4°C]			63°F [17.2°C]			
CFM [L/s]		1810 [854.2]	1450 [684.3]	1090 [514.4]	1810 [854.2]	1450 [684.3]	1090 [514.4]	1810 [854.2]	1450 [684.3]	1090 [514.4]	
DR ①		.20	.16	.10	.20	.16	.10	.20	.16	.10	
OUTDOOR DRY BULB TEMPERATURE °F [°C]	75 [23.9]	Total BTUH [kW] Sens BTUH [kW] Power	52.9 [15.50] 32.9 [9.64] 2.5	50.6 [14.83] 29.4 [8.62] 2.5	48.3 [14.16] 26.0 [7.62] 2.4	49.8 [14.59] 39.1 [11.46] 2.5	47.6 [13.95] 35.0 [10.26] 2.5	45.5 [13.33] 30.9 [9.06] 2.4	47.4 [13.89] 45.3 [13.28] 2.5	45.3 [13.28] 40.6 [11.90] 2.5	43.3 [12.69] 35.9 [10.52] 2.4
	80 [26.7]	Total BTUH [kW] Sens BTUH [kW] Power	51.5 [15.09] 32.1 [9.41] 2.7	49.3 [14.45] 28.7 [8.41] 2.6	47.0 [13.77] 25.4 [7.44] 2.6	48.5 [14.21] 38.3 [11.22] 2.7	46.3 [13.57] 34.3 [10.05] 2.6	44.2 [12.95] 30.3 [8.88] 2.6	46.0 [13.48] 44.8 [13.13] 2.7	44.0 [12.90] 39.9 [11.69] 2.6	42.0 [12.31] 35.3 [10.35] 2.6
	85 [29.4]	Total BTUH [kW] Sens BTUH [kW] Power	50.1 [14.68] 31.3 [9.17] 2.8	48.0 [14.07] 28.1 [8.24] 2.8	45.8 [13.42] 24.8 [7.27] 2.7	47.1 [13.80] 37.6 [11.02] 2.8	45.0 [13.19] 33.6 [9.85] 2.8	43.0 [12.60] 29.7 [8.70] 2.7	44.7 [13.10] 44.0 [12.90] 2.8	42.7 [12.51] 39.3 [11.52] 2.8	40.8 [11.96] 34.7 [10.17] 2.7
	90 [32.2]	Total BTUH [kW] Sens BTUH [kW] Power	48.7 [14.27] 30.7 [9.00] 3.0	46.6 [13.66] 27.4 [8.03] 2.9	44.5 [13.04] 24.2 [7.09] 2.9	45.7 [13.39] 36.9 [10.81] 3.0	43.7 [12.81] 33.0 [9.67] 2.9	41.7 [12.22] 29.2 [8.56] 2.9	43.2 [12.66] 43.0 [12.60] 3.0	41.4 [12.13] 38.7 [11.34] 2.9	39.5 [11.58] 34.2 [10.02] 2.9
	95 [35]	Total BTUH [kW] Sens BTUH [kW] Power	47.3 [13.86] 30.0 [8.79] 3.2	45.2 [13.25] 26.8 [7.85] 3.1	43.2 [12.66] 23.7 [6.95] 3.0	44.2 [12.95] 36.2 [10.61] 3.2	42.3 [12.40] 32.4 [9.50] 3.1	40.4 [11.84] 28.6 [8.38] 3.0	41.8 [12.25] 41.8 [12.25] 3.2	40.0 [11.72] 38.0 [11.14] 3.1	38.2 [11.20] 33.6 [9.85] 3.0
	100 [37.8]	Total BTUH [kW] Sens BTUH [kW] Power	45.8 [13.42] 29.2 [8.56] 3.3	43.8 [12.84] 26.2 [7.68] 3.3	41.8 [12.25] 23.1 [6.77] 3.2	42.7 [12.51] 35.4 [10.37] 3.3	40.9 [11.99] 31.7 [9.29] 3.2	39.0 [11.43] 28.0 [8.21] 3.2	40.3 [11.81] 40.3 [11.81] 3.3	38.6 [11.31] 37.4 [10.96] 3.2	36.8 [10.79] 33.0 [9.67] 3.2
	105 [40.6]	Total BTUH [kW] Sens BTUH [kW] Power	44.3 [12.98] 28.5 [8.35] 3.5	42.3 [12.40] 25.5 [7.47] 3.4	40.4 [11.84] 22.5 [6.59] 3.3	41.2 [12.07] 34.7 [10.17] 3.5	39.4 [11.55] 31.0 [9.09] 3.4	37.6 [11.02] 27.4 [8.03] 3.3	38.8 [11.37] 38.8 [11.37] 3.5	37.1 [10.87] 36.7 [10.76] 3.4	35.4 [10.37] 32.4 [9.50] 3.3
	110 [43.3]	Total BTUH [kW] Sens BTUH [kW] Power	42.7 [12.51] 27.6 [8.09] 3.6	40.8 [11.96] 24.7 [7.24] 3.6	39.0 [11.43] 21.8 [6.39] 3.5	39.6 [11.61] 33.8 [9.91] 3.6	37.9 [11.11] 30.3 [8.88] 3.6	36.2 [10.61] 26.7 [7.83] 3.5	37.2 [10.90] 37.2 [10.90] 3.6	35.6 [10.43] 35.6 [10.43] 3.6	34.0 [9.96] 31.7 [9.29] 3.5
	115 [46.1]	Total BTUH [kW] Sens BTUH [kW] Power	41.1 [12.05] 26.6 [7.80] 3.8	39.3 [11.52] 23.9 [7.00] 3.7	37.5 [10.99] 21.1 [6.18] 3.6	38.0 [11.14] 32.9 [9.64] 3.8	36.3 [10.64] 29.4 [8.62] 3.7	34.7 [10.17] 26.0 [7.62] 3.6	35.6 [10.43] 35.6 [10.43] 3.8	34.0 [9.96] 34.0 [9.96] 3.7	32.5 [9.52] 31.0 [9.09] 3.6

DR —Depression ratio  
dbE—Entering air dry bulb  
wbE—Entering air wet bulb

Total —Total capacity x 1000 BTUH  
Sens —Sensible capacity x 1000 BTUH  
Power—KW input

NOTES: ① When the entering air dry bulb is other than 80°F [27°C], adjust the sensible capacity from the table by adding  $[1.10 \times \text{CFM} \times (1 - \text{DR}) \times (\text{dbE} - 80)]$ .

[ ] Designates Metric Conversions

# SYSTEMS PERFORMANCE—RLNL- SERIES



## GROSS SYSTEMS PERFORMANCE DATA—RLNL-A048

ENTERING INDOOR AIR @ 80°F [26.7°C] dbE ①											
wbE		71°F [21.7°C]			67°F [19.4°C]			63°F [17.2°C]			
CFM [L/s]		2000 [943.8]	1600 [755.1]	1200 [566.3]	2000 [943.8]	1600 [755.1]	1200 [566.3]	2000 [943.8]	1600 [755.1]	1200 [566.3]	
DR ①		.18	.14	.09	.18	.14	.09	.18	.14	.09	
OUTDOOR DRY BULB TEMPERATURE °F [°C]	75 [23.9]	Total BTUH [kW] Sens BTUH [kW] Power	63.8 [18.70] 38.9 [11.40] 2.9	61.1 [17.91] 34.9 [10.23] 2.8	58.3 [17.09] 30.8 [9.03] 2.8	59.4 [17.41] 45.9 [13.45] 2.9	56.9 [16.68] 41.1 [12.05] 2.9	54.3 [15.91] 36.3 [10.64] 2.8	54.4 [15.94] 53.0 [15.53] 2.9	52.0 [15.24] 47.5 [13.92] 2.8	49.6 [14.54] 42.0 [12.31] 2.7
	80 [26.7]	Total BTUH [kW] Sens BTUH [kW] Power	62.0 [18.17] 38.0 [11.14] 3.1	59.3 [17.38] 34.0 [9.96] 3.0	56.6 [16.59] 30.0 [8.79] 3.0	57.6 [16.88] 44.9 [13.16] 3.1	55.1 [16.15] 40.2 [11.78] 3.0	52.6 [15.42] 35.5 [10.40] 3.0	52.5 [15.39] 52.1 [15.27] 3.1	50.3 [14.74] 46.6 [13.66] 3.0	48.0 [14.07] 41.2 [12.07] 2.9
	85 [29.4]	Total BTUH [kW] Sens BTUH [kW] Power	60.2 [17.64] 37.0 [10.84] 3.3	57.6 [16.88] 33.1 [9.70] 3.2	55.0 [16.12] 29.2 [8.56] 3.1	55.8 [16.35] 43.9 [12.87] 3.3	53.4 [15.65] 39.3 [11.52] 3.2	50.9 [14.92] 34.7 [10.17] 3.2	50.7 [14.86] 50.7 [14.86] 3.3	48.5 [14.21] 45.7 [13.39] 3.2	46.3 [13.57] 40.4 [11.84] 3.1
	90 [32.2]	Total BTUH [kW] Sens BTUH [kW] Power	58.4 [17.12] 36.0 [10.55] 3.5	55.9 [16.38] 32.2 [9.44] 3.4	53.3 [15.62] 28.4 [8.32] 3.3	54.0 [15.83] 42.9 [12.57] 3.5	51.7 [15.15] 38.4 [11.25] 3.4	49.3 [14.45] 34.0 [9.96] 3.4	48.9 [14.33] 48.9 [14.33] 3.4	46.8 [13.72] 44.8 [13.13] 3.4	44.7 [13.10] 39.6 [11.61] 3.3
	95 [35]	Total BTUH [kW] Sens BTUH [kW] Power	56.6 [16.59] 35.0 [10.26] 3.7	54.2 [15.88] 31.3 [9.17] 3.6	51.7 [15.15] 27.7 [8.12] 3.5	52.2 [15.30] 42.0 [12.31] 3.7	50.0 [14.65] 37.6 [11.02] 3.6	47.7 [13.98] 33.2 [9.73] 3.5	47.2 [13.83] 47.2 [13.83] 3.6	45.1 [13.22] 44.1 [12.92] 3.6	43.1 [12.63] 38.8 [11.37] 3.5
	100 [37.8]	Total BTUH [kW] Sens BTUH [kW] Power	54.9 [16.09] 34.1 [9.99] 3.9	52.6 [15.42] 30.5 [8.94] 3.8	50.2 [14.71] 26.9 [7.88] 3.7	50.5 [14.80] 41.0 [12.02] 3.9	48.4 [14.18] 36.7 [10.76] 3.8	46.2 [13.54] 32.5 [9.52] 3.7	45.5 [13.33] 45.5 [13.33] 3.8	43.5 [12.75] 43.1 [12.63] 3.8	41.5 [12.16] 38.1 [11.17] 3.7
	105 [40.6]	Total BTUH [kW] Sens BTUH [kW] Power	53.3 [15.62] 33.2 [9.73] 4.0	51.0 [14.95] 29.7 [8.70] 4.0	48.7 [14.27] 26.3 [7.71] 3.9	48.9 [14.33] 40.2 [11.78] 4.1	46.8 [13.72] 36.0 [10.55] 4.0	44.7 [13.10] 31.8 [9.32] 3.9	43.9 [12.87] 43.9 [12.87] 4.0	42.0 [12.31] 42.0 [12.31] 3.9	40.1 [11.75] 37.4 [10.96] 3.9
	110 [43.3]	Total BTUH [kW] Sens BTUH [kW] Power	51.9 [15.21] 32.4 [9.50] 4.2	49.6 [14.54] 29.1 [8.53] 4.2	47.4 [13.89] 25.7 [7.53] 4.1	47.5 [13.92] 39.4 [11.55] 4.3	45.4 [13.31] 35.3 [10.35] 4.2	43.3 [12.69] 31.2 [9.14] 4.1	42.4 [12.43] 42.4 [12.43] 4.2	40.5 [11.87] 40.5 [11.87] 4.1	38.7 [11.34] 36.8 [10.79] 4.1
	115 [46.1]	Total BTUH [kW] Sens BTUH [kW] Power	50.5 [14.80] 31.8 [9.32] 4.4	48.3 [14.16] 28.5 [8.35] 4.3	46.1 [13.51] 25.1 [7.36] 4.3	46.1 [13.51] 38.8 [11.37] 4.5	44.1 [12.92] 34.7 [10.17] 4.4	42.1 [12.34] 30.7 [9.00] 4.3	41.0 [12.02] 41.0 [12.02] 4.4	39.3 [11.52] 39.3 [11.52] 4.3	37.5 [10.99] 36.3 [10.64] 4.2

## GROSS SYSTEMS PERFORMANCE DATA—RLNL-A060

ENTERING INDOOR AIR @ 80°F [26.7°C] dbE ①											
wbE		71°F [21.7°C]			67°F [19.4°C]			63°F [17.2°C]			
CFM [L/s]		2380 [1123.2]	1900 [896.7]	1420 [670.1]	2380 [1123.2]	1900 [896.7]	1420 [670.1]	2380 [1123.2]	1900 [896.7]	1420 [670.1]	
DR ①		.22	.18	.15	.22	.18	.15	.22	.18	.15	
OUTDOOR DRY BULB TEMPERATURE °F [°C]	75 [23.9]	Total BTUH [kW] Sens BTUH [kW] Power	78.2 [22.92] 46.4 [13.60] 3.9	74.8 [21.92] 41.5 [12.16] 3.8	71.4 [20.93] 36.7 [10.76] 3.7	72.4 [21.22] 53.7 [15.74] 3.9	69.2 [20.28] 48.1 [14.10] 3.8	66.1 [19.37] 42.5 [12.46] 3.7	70.5 [20.66] 61.8 [18.11] 3.8	67.4 [19.75] 55.3 [16.21] 3.7	64.3 [18.84] 48.9 [14.33] 3.6
	80 [26.7]	Total BTUH [kW] Sens BTUH [kW] Power	76.2 [22.33] 45.5 [13.33] 4.1	72.9 [21.36] 40.7 [11.93] 4.0	69.6 [20.40] 36.0 [10.55] 3.9	70.4 [20.63] 52.8 [15.47] 4.1	67.3 [19.72] 47.2 [13.83] 4.0	64.2 [18.82] 41.7 [12.22] 3.9	68.4 [20.05] 60.9 [17.85] 4.0	65.4 [19.17] 54.5 [15.97] 3.9	62.5 [18.32] 48.1 [14.10] 3.8
	85 [29.4]	Total BTUH [kW] Sens BTUH [kW] Power	74.1 [21.72] 44.4 [13.01] 4.3	70.8 [20.75] 39.7 [11.63] 4.3	67.6 [19.81] 35.1 [10.29] 4.2	68.2 [19.99] 51.6 [15.12] 4.4	65.3 [19.14] 46.2 [13.54] 4.3	62.3 [18.26] 40.8 [11.96] 4.2	66.3 [19.43] 59.7 [17.50] 4.2	63.4 [18.58] 53.5 [15.68] 4.2	60.5 [17.73] 47.3 [13.86] 4.1
	90 [32.2]	Total BTUH [kW] Sens BTUH [kW] Power	71.9 [21.07] 43.1 [12.63] 4.6	68.7 [20.13] 38.6 [11.31] 4.5	65.6 [19.23] 34.1 [9.99] 4.4	66.0 [19.34] 50.4 [14.77] 4.6	63.1 [18.49] 45.1 [13.22] 4.5	60.3 [17.67] 39.9 [11.69] 4.4	64.1 [18.79] 58.5 [17.14] 4.5	61.3 [17.97] 52.4 [15.36] 4.4	58.5 [17.14] 46.3 [13.57] 4.3
	95 [35]	Total BTUH [kW] Sens BTUH [kW] Power	69.6 [20.40] 41.8 [12.25] 4.8	66.6 [19.52] 37.5 [10.99] 4.7	63.6 [18.64] 33.1 [9.70] 4.6	63.8 [18.70] 49.1 [14.39] 4.8	61.0 [17.88] 44.0 [12.90] 4.7	58.2 [17.06] 38.9 [11.40] 4.6	61.8 [18.11] 57.2 [16.76] 4.7	59.1 [17.32] 51.2 [15.01] 4.6	56.4 [16.53] 45.3 [13.28] 4.5
	100 [37.8]	Total BTUH [kW] Sens BTUH [kW] Power	67.4 [19.75] 40.6 [11.90] 5.1	64.4 [18.87] 36.3 [10.64] 5.0	61.5 [18.02] 32.1 [9.41] 4.9	61.5 [18.02] 47.8 [14.01] 5.1	58.9 [17.26] 42.8 [12.54] 5.0	56.2 [16.47] 37.8 [11.08] 4.9	59.6 [17.47] 55.9 [16.38] 5.0	57.0 [16.71] 50.1 [14.68] 4.9	54.4 [15.94] 44.3 [12.98] 4.8
	105 [40.6]	Total BTUH [kW] Sens BTUH [kW] Power	65.2 [19.11] 39.3 [11.52] 5.3	62.4 [18.29] 35.2 [10.32] 5.2	59.5 [17.44] 31.1 [9.11] 5.1	59.3 [17.38] 46.6 [13.66] 5.3	56.8 [16.65] 41.8 [12.25] 5.2	54.2 [15.88] 36.9 [10.81] 5.1	57.4 [16.82] 54.7 [16.03] 5.2	54.9 [16.09] 49.0 [14.36] 5.1	52.4 [15.36] 43.3 [12.69] 5.0
	110 [43.3]	Total BTUH [kW] Sens BTUH [kW] Power	63.1 [18.49] 38.3 [11.22] 5.6	60.4 [17.70] 34.3 [10.05] 5.4	57.6 [16.88] 30.3 [8.88] 5.3	57.3 [16.79] 45.5 [13.33] 5.6	54.8 [16.06] 40.8 [11.96] 5.5	52.3 [15.33] 36.0 [10.55] 5.3	55.3 [16.21] 53.6 [15.71] 5.5	52.9 [15.50] 48.0 [14.07] 5.3	50.5 [14.80] 42.4 [12.43] 5.2
	115 [46.1]	Total BTUH [kW] Sens BTUH [kW] Power	61.1 [17.91] 37.4 [10.96] 5.8	58.5 [17.14] 33.5 [9.82] 5.7	55.8 [16.35] 29.6 [8.67] 5.6	55.3 [16.21] 44.6 [13.07] 5.8	52.9 [15.50] 40.0 [11.72] 5.7	50.5 [14.80] 35.3 [10.35] 5.6	53.3 [15.62] 52.7 [15.44] 5.7	51.0 [14.95] 47.2 [13.83] 5.6	48.7 [14.27] 41.7 [12.22] 5.5

DR —Depression ratio  
dbE—Entering air dry bulb  
wbE—Entering air wet bulb

Total —Total capacity x 1000 BTUH  
Sens —Sensible capacity x 1000 BTUH  
Power—KW input

NOTES: ① When the entering air dry bulb is other than 80°F [27°C], adjust the sensible capacity from the table by adding  $[1.10 \times \text{CFM} \times (1 - \text{DR}) \times (\text{dbE} - 80)]$ .

[ ] Designates Metric Conversions



# SYSTEMS PERFORMANCE—RLPL- SERIES

## GROSS SYSTEMS PERFORMANCE DATA—RLPL-A036

		ENTERING INDOOR AIR @ 80°F [26.7°C] dbE ①									
wbE		71°F [21.7°C]			67°F [19.4°C]			63°F [17.2°C]			
CFM [L/s]		1500 [708]	1200 [566]	900 [425]	1500 [708]	1200 [566]	900 [425]	1500 [708]	1200 [566]	900 [425]	
DR ①		.18	.14	.08	.18	.14	.08	.18	.14	.08	
OUTDOOR DRY BULB TEMPERATURE °F [°C]	75 [23.9]	Total BTUH [kW] Sens BTUH [kW] Power	46.9 [13.75] 28.0 [8.21] 2.1	44.8 [13.13] 25.0 [7.33] 2.0	42.8 [12.54] 22.1 [6.48] 2.0	43.3 [12.69] 33.3 [9.76] 2.2	41.4 [12.13] 29.9 [8.76] 2.1	39.5 [11.58] 26.4 [7.74] 2.1	40.5 [11.87] 38.2 [11.20] 2.1	38.7 [11.34] 34.3 [10.05] 2.1	36.9 [10.81] 30.3 [8.88] 2.0
	80 [26.7]	Total BTUH [kW] Sens BTUH [kW] Power	45.8 [13.42] 27.7 [8.12] 2.2	43.8 [12.84] 24.8 [7.27] 2.2	41.8 [12.25] 21.9 [6.42] 2.1	42.2 [12.37] 33.1 [9.70] 2.3	40.3 [11.81] 29.6 [8.67] 2.3	38.5 [11.28] 26.1 [7.65] 2.2	39.3 [11.52] 38.1 [11.17] 2.3	37.6 [11.02] 34.0 [9.96] 2.2	35.9 [10.52] 30.0 [8.79] 2.2
	85 [29.4]	Total BTUH [kW] Sens BTUH [kW] Power	44.5 [13.04] 27.2 [7.97] 2.4	42.6 [12.48] 24.3 [7.12] 2.3	40.7 [11.93] 21.5 [6.30] 2.3	41.0 [12.02] 32.6 [9.55] 2.5	39.2 [11.49] 29.2 [8.56] 2.4	37.4 [10.96] 25.8 [7.56] 2.4	38.1 [11.17] 37.5 [10.99] 2.4	36.5 [10.70] 33.6 [9.85] 2.4	34.8 [10.20] 29.7 [8.70] 2.3
	90 [32.2]	Total BTUH [kW] Sens BTUH [kW] Power	43.3 [12.69] 26.5 [7.77] 2.5	41.4 [12.13] 23.7 [6.95] 2.5	39.5 [11.58] 21.0 [6.15] 2.4	39.7 [11.63] 31.9 [9.35] 2.6	37.9 [11.11] 28.6 [8.38] 2.6	36.2 [10.61] 25.2 [7.39] 2.5	36.8 [10.79] 36.7 [10.76] 2.6	35.2 [10.32] 33.0 [9.67] 2.5	33.6 [9.85] 29.1 [8.53] 2.5
	95 [35]	Total BTUH [kW] Sens BTUH [kW] Power	41.9 [12.28] 25.8 [7.56] 2.7	40.1 [11.75] 23.1 [6.77] 2.6	38.3 [11.22] 20.4 [5.98] 2.6	38.4 [11.25] 31.1 [9.11] 2.8	36.7 [10.76] 27.9 [8.18] 2.7	35.0 [10.26] 24.6 [7.21] 2.7	35.5 [10.40] 35.5 [10.40] 2.7	34.0 [9.96] 32.3 [9.47] 2.7	32.4 [9.50] 28.5 [8.35] 2.6
	100 [37.8]	Total BTUH [kW] Sens BTUH [kW] Power	40.6 [11.90] 24.9 [7.30] 2.8	38.9 [11.40] 22.3 [6.54] 2.8	37.1 [10.87] 19.7 [5.77] 2.7	37.0 [10.84] 30.3 [8.88] 2.9	35.4 [10.37] 27.2 [7.97] 2.9	33.8 [9.91] 24.0 [7.03] 2.8	34.2 [10.02] 34.2 [10.02] 2.9	32.7 [9.58] 31.6 [9.26] 2.8	31.2 [9.14] 27.9 [8.18] 2.8
	105 [40.6]	Total BTUH [kW] Sens BTUH [kW] Power	39.4 [11.55] 24.1 [7.06] 3.0	37.6 [11.02] 21.6 [6.33] 2.9	35.9 [10.52] 19.1 [5.60] 2.8	35.8 [10.49] 29.5 [8.65] 3.1	34.2 [10.02] 26.4 [7.74] 3.0	32.7 [9.58] 23.3 [6.83] 2.9	33.0 [9.67] 33.0 [9.67] 3.0	31.5 [9.23] 30.8 [9.03] 3.0	30.1 [8.82] 27.2 [7.97] 2.9
	110 [43.3]	Total BTUH [kW] Sens BTUH [kW] Power	38.2 [11.20] 23.3 [6.83] 3.1	36.5 [10.70] 20.9 [6.13] 3.1	34.8 [10.20] 18.4 [5.39] 3.0	34.6 [10.14] 28.7 [8.41] 3.2	33.1 [9.70] 25.7 [7.53] 3.1	31.6 [9.26] 22.7 [6.65] 3.1	31.8 [9.32] 31.8 [9.32] 3.2	30.4 [8.91] 30.1 [8.82] 3.1	29.0 [8.50] 26.6 [7.80] 3.0
	115 [46.1]	Total BTUH [kW] Sens BTUH [kW] Power	37.1 [10.87] 22.6 [6.62] 3.3	35.5 [10.40] 20.3 [5.95] 3.2	33.9 [9.94] 17.9 [5.25] 3.1	33.5 [9.82] 28.0 [8.21] 3.4	32.0 [9.38] 25.1 [7.36] 3.3	30.6 [8.97] 22.2 [6.51] 3.2	30.7 [9.00] 30.7 [9.00] 3.3	29.3 [8.59] 29.3 [8.59] 3.3	28.0 [8.21] 26.1 [7.65] 3.2

## GROSS SYSTEMS PERFORMANCE DATA—RLPL-A042

		ENTERING INDOOR AIR @ 80°F [26.7°C] dbE ①									
wbE		71°F [21.7°C]			67°F [19.4°C]			63°F [17.2°C]			
CFM [L/s]		1810 [854.2]	1450 [684.3]	1090 [514.4]	1810 [854.2]	1450 [684.3]	1090 [514.4]	1810 [854.2]	1450 [684.3]	1090 [514.4]	
DR ①		.20	.16	.11	.20	.16	.11	.20	.16	.11	
OUTDOOR DRY BULB TEMPERATURE °F [°C]	75 [23.9]	Total BTUH [kW] Sens BTUH [kW] Power	52.7 [15.44] 32.4 [9.50] 2.6	50.4 [14.77] 29.0 [8.50] 2.5	48.1 [14.10] 25.6 [7.50] 2.5	50.0 [14.65] 39.0 [11.43] 2.5	47.8 [14.01] 34.9 [10.23] 2.5	45.7 [13.39] 30.9 [9.06] 2.4	46.1 [13.51] 45.2 [13.25] 2.5	44.1 [12.92] 40.5 [11.87] 2.5	42.1 [12.34] 35.8 [10.49] 2.4
	80 [26.7]	Total BTUH [kW] Sens BTUH [kW] Power	51.8 [15.18] 31.9 [9.35] 2.7	49.5 [14.51] 28.5 [8.35] 2.7	47.3 [13.86] 25.2 [7.39] 2.6	49.1 [14.39] 38.5 [11.28] 2.7	46.9 [13.75] 34.5 [10.11] 2.6	44.8 [13.13] 30.4 [8.91] 2.6	45.2 [13.25] 44.7 [13.10] 2.7	43.2 [12.66] 40.0 [11.72] 2.6	41.2 [12.07] 35.4 [10.37] 2.6
	85 [29.4]	Total BTUH [kW] Sens BTUH [kW] Power	50.6 [14.83] 31.3 [9.17] 2.9	48.4 [14.18] 28.0 [8.21] 2.8	46.2 [13.54] 24.7 [7.24] 2.8	47.9 [14.04] 37.9 [11.11] 2.9	45.8 [13.42] 33.9 [9.94] 2.8	43.7 [12.81] 30.0 [8.79] 2.7	43.9 [12.87] 43.9 [12.87] 2.8	42.0 [12.31] 39.5 [11.58] 2.8	40.1 [11.75] 34.9 [10.23] 2.7
	90 [32.2]	Total BTUH [kW] Sens BTUH [kW] Power	49.1 [14.39] 30.5 [8.94] 3.0	47.0 [13.77] 27.3 [8.00] 3.0	44.9 [13.16] 24.2 [7.09] 2.9	46.4 [13.60] 37.1 [10.87] 3.0	44.4 [13.01] 33.3 [9.76] 2.9	42.4 [12.43] 29.4 [8.62] 2.9	42.5 [12.46] 42.5 [12.46] 3.0	40.7 [11.93] 38.8 [11.37] 2.9	38.8 [11.37] 34.3 [10.05] 2.9
	95 [35]	Total BTUH [kW] Sens BTUH [kW] Power	47.5 [13.92] 29.7 [8.70] 3.2	45.5 [13.33] 26.6 [7.80] 3.1	43.4 [12.72] 23.5 [6.89] 3.1	44.8 [13.13] 36.4 [10.67] 3.2	42.9 [12.57] 32.6 [9.55] 3.1	40.9 [11.99] 28.8 [8.44] 3.0	40.9 [11.99] 40.9 [11.99] 3.2	39.1 [11.46] 38.3 [11.22] 3.1	37.3 [10.93] 33.7 [9.88] 3.0
	100 [37.8]	Total BTUH [kW] Sens BTUH [kW] Power	45.8 [13.42] 28.9 [8.47] 3.4	43.8 [12.84] 25.9 [7.59] 3.3	41.8 [12.25] 22.9 [6.71] 3.2	43.1 [12.63] 35.5 [10.40] 3.3	41.2 [12.07] 31.8 [9.32] 3.3	39.4 [11.55] 28.1 [8.24] 3.2	39.2 [11.49] 39.2 [11.49] 3.3	37.5 [10.99] 37.2 [10.90] 3.2	35.8 [10.49] 33.0 [9.67] 3.2
	105 [40.6]	Total BTUH [kW] Sens BTUH [kW] Power	44.1 [12.92] 28.0 [8.21] 3.5	42.1 [12.34] 25.1 [7.36] 3.4	40.2 [11.78] 22.2 [6.51] 3.4	41.3 [12.10] 34.6 [10.14] 3.5	39.5 [11.58] 31.0 [9.09] 3.4	37.7 [11.05] 27.4 [8.03] 3.3	37.4 [10.96] 37.4 [10.96] 3.5	35.8 [10.49] 35.8 [10.49] 3.4	34.2 [10.02] 32.3 [9.47] 3.3
	110 [43.3]	Total BTUH [kW] Sens BTUH [kW] Power	42.3 [12.40] 27.1 [7.94] 3.7	40.5 [11.87] 24.3 [7.12] 3.6	38.6 [11.31] 21.5 [6.30] 3.5	39.6 [11.61] 33.7 [9.88] 3.6	37.9 [11.11] 30.2 [8.85] 3.6	36.2 [10.61] 26.7 [7.83] 3.5	35.7 [10.46] 35.7 [10.46] 3.6	34.1 [9.99] 34.1 [9.99] 3.6	32.6 [9.55] 31.6 [9.26] 3.5
	115 [46.1]	Total BTUH [kW] Sens BTUH [kW] Power	40.6 [11.90] 26.2 [7.68] 3.8	38.9 [11.40] 23.5 [6.89] 3.7	37.1 [10.87] 20.8 [6.10] 3.7	37.9 [11.11] 32.8 [9.61] 3.8	36.3 [10.64] 29.4 [8.62] 3.7	34.6 [10.14] 26.0 [7.62] 3.6	34.0 [9.96] 34.0 [9.96] 3.8	32.5 [9.52] 32.5 [9.52] 3.7	31.1 [9.11] 30.9 [9.06] 3.6

DR —Depression ratio  
dbE—Entering air dry bulb  
wbE—Entering air wet bulb

Total —Total capacity x 1000 BTUH  
Sens —Sensible capacity x 1000 BTUH  
Power—KW input

NOTES: ① When the entering air dry bulb is other than 80°F [27°C], adjust the sensible capacity from the table by adding  $[1.10 \times \text{CFM} \times (1 - \text{DR}) \times (\text{dbE} - 80)]$ .

[ ] Designates Metric Conversions

# SYSTEMS PERFORMANCE—RLPL- SERIES



## GROSS SYSTEMS PERFORMANCE DATA—RLPL-A048

ENTERING INDOOR AIR @ 80°F [26.7°C] dbE ①											
wbE		71°F [21.7°C]			67°F [19.4°C]			63°F [17.2°C]			
CFM [L/s]		2000 [943.8]	1600 [755.1]	1200 [566.3]	2000 [943.8]	1600 [755.1]	1200 [566.3]	2000 [943.8]	1600 [755.1]	1200 [566.3]	
DR ①		.17	.13	.08	.17	.13	.08	.17	.13	.08	
OUTDOOR DRY BULB TEMPERATURE °F [°C]	75 [23.9]	Total BTUH [kW] Sens BTUH [kW] Power	63.2 [18.52] 38.5 [11.28] 2.9	60.4 [17.70] 34.4 [10.08] 2.8	57.7 [16.91] 30.4 [8.91] 2.8	59.4 [17.41] 45.8 [13.42] 2.9	56.8 [16.65] 41.0 [12.02] 2.9	54.2 [15.88] 36.2 [10.61] 2.8	53.7 [15.74] 52.6 [15.42] 2.9	51.4 [15.06] 47.1 [13.80] 2.8	49.0 [14.36] 41.6 [12.19] 2.8
	80 [26.7]	Total BTUH [kW] Sens BTUH [kW] Power	61.1 [17.91] 37.1 [10.87] 3.1	58.5 [17.14] 33.3 [9.76] 3.0	55.8 [16.35] 29.4 [8.62] 3.0	57.3 [16.79] 44.5 [13.04] 3.1	54.8 [16.06] 39.9 [11.69] 3.0	52.3 [15.33] 35.2 [10.32] 3.0	51.6 [15.12] 51.3 [15.03] 3.1	49.4 [14.48] 45.9 [13.45] 3.0	47.1 [13.80] 40.5 [11.87] 2.9
	85 [29.4]	Total BTUH [kW] Sens BTUH [kW] Power	59.4 [17.41] 36.2 [10.61] 3.3	56.8 [16.65] 32.4 [9.50] 3.2	54.2 [15.88] 28.6 [8.38] 3.1	55.6 [16.29] 43.6 [12.78] 3.3	53.2 [15.59] 39.0 [11.43] 3.2	50.8 [14.89] 34.5 [10.11] 3.2	49.9 [14.62] 49.9 [14.62] 3.3	47.7 [13.98] 45.1 [13.22] 3.2	45.6 [13.36] 39.8 [11.66] 3.1
	90 [32.2]	Total BTUH [kW] Sens BTUH [kW] Power	57.9 [16.97] 35.5 [10.40] 3.5	55.4 [16.24] 31.8 [9.32] 3.4	52.9 [15.50] 28.1 [8.24] 3.3	54.1 [15.86] 42.9 [12.57] 3.5	51.8 [15.18] 38.4 [11.25] 3.4	49.4 [14.48] 33.9 [9.94] 3.3	48.4 [14.18] 48.4 [14.18] 3.5	46.3 [13.57] 44.4 [13.01] 3.4	44.2 [12.95] 39.2 [11.49] 3.3
	95 [35]	Total BTUH [kW] Sens BTUH [kW] Power	56.6 [16.59] 34.9 [10.23] 3.7	54.1 [15.86] 31.3 [9.17] 3.6	51.7 [15.15] 27.6 [8.09] 3.5	52.8 [15.47] 42.3 [12.40] 3.7	50.5 [14.80] 37.9 [11.11] 3.6	48.2 [14.13] 33.4 [9.79] 3.5	47.1 [13.80] 47.1 [13.80] 3.6	45.0 [13.19] 44.0 [12.90] 3.6	43.0 [12.60] 38.8 [11.37] 3.5
	100 [37.8]	Total BTUH [kW] Sens BTUH [kW] Power	55.2 [16.18] 34.3 [10.05] 3.9	52.8 [15.47] 30.8 [9.03] 3.8	50.4 [14.77] 27.2 [7.97] 3.7	51.4 [15.06] 41.7 [12.22] 3.9	49.2 [14.42] 37.3 [10.93] 3.8	46.9 [13.75] 33.0 [9.67] 3.7	45.7 [13.39] 45.7 [13.39] 3.8	43.7 [12.81] 43.3 [12.69] 3.8	41.8 [12.25] 38.3 [11.22] 3.7
	105 [40.6]	Total BTUH [kW] Sens BTUH [kW] Power	53.7 [15.74] 33.6 [9.85] 4.0	51.4 [15.06] 30.1 [8.82] 4.0	49.1 [14.39] 26.6 [7.80] 3.9	49.9 [14.62] 41.0 [12.02] 4.1	47.7 [13.98] 36.7 [10.76] 4.0	45.6 [13.36] 32.4 [9.50] 3.9	44.2 [12.95] 44.2 [12.95] 4.0	42.3 [12.40] 42.3 [12.40] 3.9	40.4 [11.84] 37.8 [11.08] 3.9
	110 [43.3]	Total BTUH [kW] Sens BTUH [kW] Power	52.0 [15.24] 32.7 [9.58] 4.2	49.7 [14.57] 29.3 [8.59] 4.1	47.5 [13.92] 25.8 [7.56] 4.1	48.2 [14.13] 40.0 [11.72] 4.2	46.1 [13.51] 35.8 [10.49] 4.2	44.0 [12.90] 31.7 [9.29] 4.1	42.5 [12.46] 42.5 [12.46] 4.2	40.7 [11.93] 40.7 [11.93] 4.1	38.8 [11.37] 37.0 [10.84] 4.0
	115 [46.1]	Total BTUH [kW] Sens BTUH [kW] Power	49.9 [14.62] 31.3 [9.17] 4.4	47.7 [13.98] 28.0 [8.21] 4.3	45.5 [13.33] 24.8 [7.27] 4.2	46.0 [13.48] 38.7 [11.34] 4.4	44.0 [12.90] 34.6 [10.14] 4.3	42.0 [12.31] 30.6 [8.97] 4.3	40.4 [11.84] 40.4 [11.84] 4.4	38.6 [11.31] 38.6 [11.31] 4.3	36.9 [10.81] 35.9 [10.52] 4.2

## GROSS SYSTEMS PERFORMANCE DATA—RLPL-A060

ENTERING INDOOR AIR @ 80°F [26.7°C] dbE ①											
wbE		71°F [21.7°C]			67°F [19.4°C]			63°F [17.2°C]			
CFM [L/s]		2310 [1090.1]	1850 [873.1]	1390 [656]	2310 [1090.1]	1850 [873.1]	1390 [656]	2310 [1090.1]	1850 [873.1]	2310 [1090.1]	
DR ①		.20	.17	.13	.20	.17	.13	.20	.17	.13	
OUTDOOR DRY BULB TEMPERATURE °F [°C]	75 [23.9]	Total BTUH [kW] Sens BTUH [kW] Power	77.5 [22.71] 45.5 [13.33] 3.6	74.2 [21.75] 40.7 [11.93] 3.5	70.8 [20.75] 36.0 [10.55] 3.5	71.2 [20.87] 52.6 [15.42] 3.6	68.1 [19.96] 47.1 [13.80] 3.5	65.0 [19.05] 41.6 [12.19] 3.4	65.8 [19.28] 62.5 [18.32] 3.6	63.0 [18.46] 56.0 [16.41] 3.5	60.1 [17.61] 49.5 [14.51] 3.4
	80 [26.7]	Total BTUH [kW] Sens BTUH [kW] Power	75.7 [22.19] 44.6 [13.07] 3.8	72.4 [21.22] 40.0 [11.72] 3.8	69.1 [20.25] 35.3 [10.35] 3.7	69.4 [20.34] 51.8 [15.18] 3.8	66.4 [19.46] 46.4 [13.60] 3.7	63.4 [18.58] 41.0 [12.02] 3.7	64.0 [18.76] 61.8 [18.11] 3.8	61.2 [17.94] 55.3 [16.21] 3.7	58.4 [17.12] 48.8 [14.30] 3.6
	85 [29.4]	Total BTUH [kW] Sens BTUH [kW] Power	74.0 [21.69] 43.8 [12.84] 4.1	70.8 [20.75] 39.2 [11.49] 4.0	67.6 [19.81] 34.7 [10.17] 3.9	67.7 [19.84] 51.0 [14.95] 4.0	64.8 [18.99] 45.6 [13.36] 4.0	61.9 [18.14] 40.3 [11.81] 3.9	62.4 [18.29] 61.0 [17.88] 4.0	59.6 [17.47] 54.6 [16.00] 3.9	56.9 [16.68] 48.2 [14.13] 3.8
	90 [32.2]	Total BTUH [kW] Sens BTUH [kW] Power	72.4 [21.22] 43.0 [12.60] 4.3	69.3 [20.31] 38.5 [11.28] 4.2	66.1 [19.37] 34.0 [9.96] 4.1	66.1 [19.37] 50.2 [14.71] 4.3	63.3 [18.55] 44.9 [13.16] 4.2	60.4 [17.70] 39.7 [11.63] 4.1	60.7 [17.79] 60.1 [17.61] 4.2	58.1 [17.03] 53.9 [15.80] 4.1	55.5 [16.27] 47.6 [13.95] 4.1
	95 [35]	Total BTUH [kW] Sens BTUH [kW] Power	70.8 [20.75] 42.2 [12.37] 4.5	67.7 [19.84] 37.8 [11.08] 4.4	64.6 [18.93] 33.4 [9.79] 4.3	64.5 [18.90] 49.4 [14.48] 4.5	61.7 [18.08] 44.2 [12.95] 4.4	58.9 [17.26] 39.0 [11.43] 4.3	59.1 [17.32] 59.1 [17.32] 4.5	56.5 [16.56] 53.1 [15.56] 4.4	54.0 [15.83] 46.9 [13.75] 4.3
	100 [37.8]	Total BTUH [kW] Sens BTUH [kW] Power	69.0 [20.22] 41.3 [12.10] 4.7	66.0 [19.34] 37.0 [10.84] 4.6	63.0 [18.46] 32.7 [9.58] 4.6	62.7 [18.38] 48.5 [14.21] 4.7	60.0 [17.58] 43.4 [12.72] 4.6	57.3 [16.79] 38.3 [11.22] 4.5	57.3 [16.79] 57.3 [16.79] 4.7	54.8 [16.06] 52.3 [15.33] 4.6	52.3 [15.33] 46.2 [13.54] 4.5
	105 [40.6]	Total BTUH [kW] Sens BTUH [kW] Power	67.0 [19.64] 40.3 [11.81] 5.0	64.1 [18.79] 36.1 [10.58] 4.9	61.2 [17.94] 31.9 [9.35] 4.8	60.7 [17.79] 47.5 [13.92] 4.9	58.1 [17.03] 42.5 [12.46] 4.8	55.4 [16.24] 37.5 [10.99] 4.7	55.3 [16.21] 55.3 [16.21] 4.9	52.9 [15.50] 51.4 [15.06] 4.8	50.5 [14.80] 45.4 [13.31] 4.7
	110 [43.3]	Total BTUH [kW] Sens BTUH [kW] Power	64.7 [18.96] 39.2 [11.49] 5.2	61.9 [18.14] 35.1 [10.29] 5.1	59.1 [17.32] 31.0 [9.09] 5.0	58.4 [17.12] 46.3 [13.57] 5.2	55.9 [16.38] 41.5 [12.16] 5.1	53.3 [15.62] 36.6 [10.73] 5.0	53.0 [15.53] 53.0 [15.53] 5.1	50.7 [14.86] 50.4 [14.77] 5.0	48.4 [14.18] 44.5 [13.04] 4.9
	115 [46.1]	Total BTUH [kW] Sens BTUH [kW] Power	61.9 [18.14] 37.8 [11.08] 5.4	59.2 [17.35] 33.9 [9.94] 5.3	56.6 [16.59] 29.9 [8.76] 5.2	55.6 [16.29] 45.0 [13.19] 5.4	53.2 [15.59] 40.3 [11.81] 5.3	50.8 [14.89] 35.6 [10.43] 5.2	50.3 [14.74] 50.3 [14.74] 5.4	48.1 [14.10] 48.1 [14.10] 5.3	45.9 [13.45] 43.4 [12.72] 5.1

DR —Depression ratio  
dbE—Entering air dry bulb  
wbE—Entering air wet bulb

Total —Total capacity x 1000 BTUH  
Sens —Sensible capacity x 1000 BTUH  
Power—KW input

NOTES: ① When the entering air dry bulb is other than 80°F [27°C], adjust the sensible capacity from the table by adding  $[1.10 \times \text{CFM} \times (1 - \text{DR}) \times (\text{dbE} - 80)]$ .

[ ] Designates Metric Conversions



## DIRECT-DRIVE 208 AIRFLOW PERFORMANCE

Unit Model	Motor Speed From Factory		Heating Input BTU/hr [kW]	Manufacturer Recommended Air-Flow Range (Min/Max) CFM	Blower Size/ Motor HP [W] # of Speeds	Motor Speed	CFM [L/s] Air Delivery/RPM/Watts—208 Volts																	
	Cool	Heat					External Static Pressure—Inches W.C. [kPa]																	
							0.1 [.02]	0.2 [.05]	0.3 [.07]	0.4 [.10]	0.5 [.12]	0.6 [.15]	0.7 [.17]	0.8 [.20]										
RLNL-A036	Low	Low	[06] [10] [12] [15] [20]	1050/1350	10x10 1/2 HP [373] 3 Speed Motor	Low	CFM	1210 [571]	1193 [563]	1175 [555]	1155 [545]	1125 [531]	1075 [507]	1015 [479]	925 [437]									
							Watts	450	400	395	385	380	375	370	360									
							CFM	1515 [715]	1500 [708]	1475 [696]	1450 [684]	1405 [663]	1350 [637]	1275 [602]	1180 [557]									
	High	High	High	1680 [793]	1650 [779]	1625 [767]	1580 [746]	1530 [722]	1460 [689]	1390 [656]	1338 [631]	1280 [604]	1280 [604]	1280 [604]	1280 [604]									
																Watts	650	640	630	610	580	560	545	515
																CFM	1210 [571]	1193 [563]	1175 [555]	1155 [545]	1125 [531]	1075 [507]	1015 [479]	925 [437]
RLNL-A042	Med	Med	[06] [10] [12] [15] [20]	1225/1575	10x10 1/2 HP [373] 3 Speed Motor	Med	CFM	1515 [715]	1500 [708]	1475 [696]	1450 [684]	1405 [663]	1350 [637]	1275 [602]	1180 [557]									
							Watts	525	515	510	505	490	475	460	445									
							CFM	1680 [793]	1650 [779]	1625 [767]	1580 [746]	1530 [722]	1460 [689]	1390 [656]	1280 [604]									
	High	High	High	1680 [793]	1650 [779]	1625 [767]	1580 [746]	1530 [722]	1460 [689]	1390 [656]	1338 [631]	1280 [604]	1280 [604]	1280 [604]	1280 [604]									
																Watts	650	640	630	610	580	560	545	515
																CFM	1210 [571]	1193 [563]	1175 [555]	1155 [545]	1125 [531]	1075 [507]	1015 [479]	925 [437]
RLNL-A048	Med	Med	[06] [10] [12] [15] [20]	1400/1800	10x10 1/2 HP [373] 3 Speed Motor	Low	CFM	1210 [571]	1193 [563]	1175 [555]	1155 [545]	1125 [531]	1075 [507]	1015 [479]	925 [437]									
							Watts	450	400	395	385	380	375	370	360									
							CFM	1515 [715]	1500 [708]	1475 [696]	1450 [684]	1405 [663]	1350 [637]	1275 [602]	1180 [557]									
	High	High	High	1680 [793]	1650 [779]	1625 [767]	1580 [746]	1530 [722]	1460 [689]	1390 [656]	1338 [631]	1280 [604]	1280 [604]	1280 [604]	1280 [604]									
																Watts	650	640	630	610	580	560	545	515
																CFM	1210 [571]	1193 [563]	1175 [555]	1155 [545]	1125 [531]	1075 [507]	1015 [479]	925 [437]
RLNL-A060	Med	Med	[06] [10] [12] [15] [20]	1750/2250	10x10 1 HP [745] 3 Speed Motor (X-13)	Low	CFM	1575 [743]	1536 [725]	1496 [706]	1457 [688]	1417 [669]	1377 [650]	1338 [631]	1298 [613]									
							Watts	297	314	330	347	364	381	397	414									
							CFM	1985 [937]	1954 [922]	1919 [906]	1876 [885]	1824 [861]	1759 [830]	1679 [792]	1581 [746]									
	High	High	High	2431 [1147]	2372 [1119]	2306 [1088]	2228 [1051]	2138 [1009]	2032 [959]	1907 [900]	1762 [832]	1762 [832]	1762 [832]	1762 [832]	1762 [832]									
																Watts	535	553	574	593	606	609	599	572
																CFM	2431 [1147]	2372 [1119]	2306 [1088]	2228 [1051]	2138 [1009]	2032 [959]	1907 [900]	1762 [832]
Watts	970	981	964	926	872	806	736	665																

[ ] Designates Metric Conversions



## DIRECT-DRIVE 230 AIRFLOW PERFORMANCE

Unit Model	Motor Speed From Factory		Heating Input BTU/hr [KW]	Manufacturer Recommended Air-Flow Range (Min/Max) CFM	Blower Size/ Motor HP [w] # of Speeds	Motor Speed	CFM [L/s] Air Delivery/RPM/Watts—230 Volts									
	Cool	Heat					External Static Pressure—Inches W.C. [kPa]									
							0.1 [0.2]	0.2 [0.05]	0.3 [0.07]	0.4 [0.10]	0.5 [0.12]	0.6 [0.15]	0.7 [0.17]	0.8 [0.20]		
RLNL-A036	Low	Low	[06] [10] [12] [15] [20]	1050/1350	10x10 1/2 HP [373] 3 Speed Motor	Low	CFM	1400 [661]	1375 [649]	1360 [642]	1335 [630]	1305 [616]	1255 [592]	1210 [571]	1100 [519]	
							Watts	470	460	455	450	440	435	425	410	
	Med	Low					CFM	1685 [795]	1620 [765]	1580 [746]	1550 [732]	1500 [708]	1430 [675]	1360 [637]	1230 [580]	
							Watts	635	600	580	570	550	535	505	475	
	High	Low					CFM	1870 [883]	1830 [864]	1790 [845]	1730 [816]	1660 [783]	1580 [746]	1500 [708]	1375 [649]	
							Watts	780	760	740	700	660	635	600	555	
RLNL-A042	Med	Med	[06] [10] [12] [15] [20]	1225/1575	10x10 1/2 HP [373] 3 Speed Motor	Med	CFM	1400 [661]	1375 [649]	1360 [642]	1335 [630]	1305 [616]	1255 [592]	1210 [571]	1100 [519]	
							Watts	470	460	455	450	440	435	425	410	
	High	Med					CFM	1685 [795]	1620 [765]	1580 [746]	1550 [732]	1500 [708]	1430 [675]	1360 [637]	1230 [580]	
							Watts	635	600	580	570	550	535	505	475	
	Low	Med					CFM	1870 [883]	1830 [864]	1790 [845]	1730 [816]	1660 [783]	1580 [746]	1500 [708]	1375 [649]	
							Watts	780	760	740	700	660	635	600	555	
RLNL-A048	Med	Med	[06] [10] [12] [15] [20]	1400/1800	10x10 1/2 HP [373] 3 Speed Motor	Med	CFM	1400 [661]	1375 [649]	1360 [642]	1335 [630]	1305 [616]	1255 [592]	1210 [571]	1100 [519]	
							Watts	470	460	455	450	440	435	425	410	
	High	Med					CFM	1685 [795]	1620 [765]	1580 [746]	1550 [732]	1500 [708]	1430 [675]	1360 [637]	1230 [580]	
							Watts	635	600	580	570	550	535	505	475	
	Low	Med					CFM	1870 [883]	1830 [864]	1790 [845]	1730 [816]	1660 [783]	1580 [746]	1500 [708]	1375 [649]	
							Watts	780	760	740	700	660	635	600	555	
RLNL-A060	Med	Med	[06] [10] [12] [15] [20]	1750/2250	10x10 1 HP [745] 3 Speed Motor (X-13)	Med	CFM	1575 [743]	1536 [725]	1496 [706]	1457 [688]	1417 [669]	1377 [650]	1338 [631]	1298 [613]	
							Watts	297	314	330	347	364	381	397	414	
	High	Med					CFM	1985 [937]	1954 [922]	1919 [906]	1876 [885]	1824 [861]	1759 [830]	1679 [792]	1581 [746]	
							Watts	535	553	574	593	606	609	599	572	
	Low	Med					CFM	2431 [1147]	2372 [1119]	2306 [1088]	2228 [1051]	2138 [1009]	2032 [959]	1907 [900]	1762 [832]	
							Watts	970	981	964	926	872	806	736	665	

[ ] Designates Metric Conversions



## DIRECT-DRIVE 460 AIRFLOW PERFORMANCE

Unit Model	Motor Speed From Factory		Heating Input BTU/hr [kW]	Manufacturer Recommended Air-Flow Range (Min/Max) CFM	Blower Size/ Motor HP [w] # of Speeds	Motor Speed	CFM [L/s] Air Delivery/RPM/Watts—460 Volts									
	Cool	Heat					External Static Pressure—Inches W.C. [kPa]									
							0.1 [0.2]	0.2 [0.5]	0.3 [0.7]	0.4 [1.0]	0.5 [1.2]	0.6 [1.5]	0.7 [1.7]	0.8 [2.0]		
RLNL-A036	Low	Low	[06] [10] [12] [15] [20]	1050/1350	10x10 1/2 HP [373] 3 Speed Motor (PSC)	Low	1400 [661]	1375 [649]	1360 [642]	1335 [630]	450	1305 [616]	1255 [592]	1210 [571]	1100 [519]	
						Watts	470	460	455	450	440	435	425	410		
	Med	Med	[06] [10] [12] [15] [20]	1225/1575	10x10 1/2 HP [373] 3 Speed Motor (PSC)	Med	1685 [795]	1620 [765]	1580 [746]	1550 [732]	580	1500 [708]	1430 [675]	1350 [637]	1230 [580]	
						Watts	635	600	580	570	550	535	505	475		
RLNL-A042	Med	Med	[06] [10] [12] [15] [20]	1400/1800	10x10 1/2 HP [373] 3 Speed Motor (PSC)	High	1870 [883]	1830 [864]	1790 [845]	1730 [816]	700	660 [783]	635 [746]	600 [708]	555 [649]	
						Watts	780	760	740	700	660	635	600	555		
	Low	Low	[06] [10] [12] [15] [20]	1750/2250	10x10 1 HP [745] 3 Speed Motor (X-13)	Low	1400 [661]	1375 [649]	1360 [642]	1335 [630]	450	1305 [616]	1255 [592]	1210 [571]	1100 [519]	
						Watts	470	460	455	450	440	435	425	410		
RLNL-A048	Med	Med	[06] [10] [12] [15] [20]	1400/1800	10x10 1/2 HP [373] 3 Speed Motor (PSC)	Med	1685 [795]	1620 [765]	1580 [746]	1550 [732]	580	1500 [708]	1430 [675]	1350 [637]	1230 [580]	
						Watts	635	600	580	570	550	535	505	475		
	High	High	[06] [10] [12] [15] [20]	1750/2250	10x10 1 HP [745] 3 Speed Motor (X-13)	High	1870 [883]	1830 [864]	1790 [845]	1730 [816]	700	660 [783]	635 [746]	600 [708]	555 [649]	
						Watts	780	760	740	700	660	635	600	555		
RLNL-A060	Med	Med	[06] [10] [12] [15] [20]	1750/2250	10x10 1 HP [745] 3 Speed Motor (X-13)	Low	1575 [743]	1536 [725]	1496 [706]	1457 [688]	330	1417 [669]	1377 [650]	1338 [631]	1298 [613]	
						Watts	297	314	330	347	364	381	397	414		
	Med	Med	[06] [10] [12] [15] [20]	1750/2250	10x10 1 HP [745] 3 Speed Motor (X-13)	Med	1985 [937]	1954 [922]	1919 [906]	1876 [885]	574	1824 [861]	1759 [830]	1679 [792]	1581 [746]	
						Watts	535	553	574	593	606	609	599	572		
High	High	[06] [10] [12] [15] [20]	1750/2250	10x10 1 HP [745] 3 Speed Motor (X-13)	High	2431 [1147]	2372 [1119]	2306 [1088]	2228 [1051]	964	2138 [1009]	2032 [959]	1907 [900]	1762 [832]		
					Watts	970	981	964	926	872	806	736	665			

[ ] Designates Metric Conversions



## DIRECT-DRIVE 208 AIRFLOW PERFORMANCE

Unit Model Cooling Capacity Tons [kW]	Motor Speed from Factory		Heating Input BTU/hr [kW]	Manufacturer Recommended Air-Flow Range (Min/Max) CFM	Blower Size/ Motor HP [w] # of Speeds	Motor Speed	CFM [L/s] Air Delivery/RPM/Watts—208 Volts Side Discharge—Wet Coil								
	Cool	Heat					External Static Pressure—Inches W.C. [kPa]								
							0.1 [0.2]	0.2 [0.05]	0.3 [0.07]	0.4 [0.10]	0.5 [0.12]	0.6 [0.15]	0.7 [0.17]	0.8 [0.20]	
RLPL-A036 3.0 [10.55]	Low (Tap 2)	Low (Tap 2)	[06]	1050/1350	10 x 10 1/2 HP [373] 3 Speed (X-13 Motor)	Low (Tap 2)	CFM	1381 [652]	1339 [632]	1291 [609]	1236 [583]	1193 [563]	1144 [540]	1079 [509]	1004 [474]
			RPM				675	717	766	808	855	903	961	1016	
			Watts				200	214	225	233	248	262	275	289	
			CFM				1479 [698]	1432 [676]	1385 [654]	1346 [635]	1304 [615]	1256 [593]	1201 [567]	1137 [537]	
RLPL-A042 3.5 [12.31]	Med. (Tap 2)	Med. (Tap 2)	[06]	1225/1575	10 x 10 3/4 HP [559] 4 Speed (X-13 Motor)	Med. (Tap 2)	CFM	1643 [775]	1605 [757]	1567 [740]	1523 [719]	1479 [698]	1441 [680]	1403 [662]	1365 [644]
			RPM				768	805	842	887	932	971	1009	1048	
			Watts				304	319	333	350	366	381	395	410	
			CFM				1643 [775]	1605 [757]	1567 [740]	1523 [719]	1479 [698]	1441 [680]	1403 [662]	1365 [644]	
RLPL-A048 4.0 [14.07]	Med. (Tap 2)	Med. (Tap 2)	[06]	1400/1800	10 x 10 3/4 HP [559] 4 Speed (X-13 Motor)	Med. (Tap 2)	CFM	1457 [688]	1410 [665]	1363 [643]	1322 [624]	1280 [604]	1235 [583]	1190 [562]	1106 [522]
			RPM				710	763	816	858	900	951	1002	1061	
			Watts				229	241	252	267	282	299	315	330	
			CFM				1717 [810]	1676 [791]	1635 [772]	1596 [753]	1556 [734]	1514 [715]	1471 [694]	1425 [673]	
RLPL-A060 5.0 [17.59]	Med. (Tap 2)	Med. (Tap 2)	[06]	1750/2250	10 x 10 1 HP [745] 3 Speed (X-13 Motor)	High (Tap 4)	CFM	1575 [743]	1536 [725]	1496 [706]	1457 [688]	1417 [669]	1377 [650]	1338 [631]	1298 [613]
			RPM				741	783	824	866	907	949	990	1032	
			Watts				297	314	330	347	364	381	397	414	
			CFM				1985 [937]	1954 [922]	1919 [906]	1876 [885]	1824 [861]	1759 [830]	1679 [792]	1581 [746]	
RLPL-A060 5.0 [17.59]	Med. (Tap 2)	Med. (Tap 2)	[10]	1750/2250	10 x 10 1 HP [745] 3 Speed (X-13 Motor)	High (Tap 4)	CFM	2431 [1147]	2372 [1119]	2306 [1088]	2228 [1051]	2138 [1009]	2032 [959]	1907 [900]	1762 [832]
			RPM				1076	1089	1102	1114	1125	1133	1142	1151	
			Watts				970	981	964	926	872	806	736	665	
			CFM				2431 [1147]	2372 [1119]	2306 [1088]	2228 [1051]	2138 [1009]	2032 [959]	1907 [900]	1762 [832]	

[ ] Designates Metric Conversions



## DIRECT-DRIVE 230/460 AIRFLOW PERFORMANCE

Unit Model Cooling Capacity Tons [kW]	Motor Speed from Factory		Heating Input BTU/hr [kW]	Manufacturer Recommended Air-Flow Range (Min/Max) CFM	Blower Size/ Motor HP [w] # of Speeds	Motor Speed	CFM [L/s] Air Delivery/RPM/Watts—230/460 Volts Side Discharge—Wet Coil									
	External Static Pressure—Inches W.C. [kPa]															
	Cool	Heat					0.1 [L02]	0.2 [L05]	0.3 [L07]	0.4 [L10]	0.5 [L12]	0.6 [L15]	0.7 [L17]	0.8 [L20]		
RLPL-A036 3.0 [10.55]			[06]	1050/1350	10 x 10 1/2 HP [373] 3 Speed (X-13 Motor)	Low (Tap 2)	CFM 1381 [652]	1339 [632]	1291 [609]	1236 [583]	1193 [563]	1144 [540]	1079 [509]	1004 [474]	1016	
	Low (Tap 2)	Watts 200	[10] [12]			717	214	225	233	248	262	275	289			
	Med. (Tap 3)	CFM 1479 [698]	1432 [676]			1385 [654]	1346 [635]	1304 [615]	1256 [593]	1201 [567]	1137 [537]	1024				
	High (Tap 4)	RPM 706	751			795	835	874	919	970	336					
		Watts 242	254			266	282	291	306	319	336					
		CFM 1669 [788]	1626 [767]			1585 [748]	1544 [729]	1500 [708]	1460 [689]	1418 [669]	1376 [649]	442				
RLPL-A042 3.5 [12.31]			[06]	1225/1575	10 x 10 3/4 HP [559] 4 Speed (X-13 Motor)	Low (Tap 1)	CFM 1444 [681]	1396 [659]	1347 [636]	1306 [616]	1265 [597]	1225 [578]	1185 [559]	1108 [523]	1038	
	Med. (Tap 2)	Watts 208	[10] [12]			731	223	237	253	268	281	293	317			
	Med. (Tap 3)	CFM 1643 [775]	1605 [757]			1567 [740]	1523 [719]	1479 [698]	1441 [680]	1403 [662]	1365 [644]	410				
	High (Tap 4)	RPM 768	805			842	887	932	971	1009	1048					
		Watts 304	319			333	350	366	381	395	410					
		CFM 1875 [885]	1837 [867]			1799 [849]	1755 [828]	1711 [808]	1673 [790]	1635 [772]	1597 [754]	546				
RLPL-A048 4.0 [14.07]			[06]	1400/1800	10 x 10 3/4 HP [559] 4 Speed (X-13 Motor)	Low (Tap 1)	CFM 1457 [688]	1410 [665]	1363 [643]	1322 [624]	1280 [604]	1235 [583]	1190 [562]	1106 [522]	1061	
	Med. (Tap 2)	Watts 229	[10] [12]			763	241	252	267	282	299	315	330			
	Med. (Tap 3)	CFM 1717 [810]	1676 [791]			1635 [772]	1596 [753]	1556 [734]	1514 [715]	1471 [694]	1425 [673]	461				
	High (Tap 4)	RPM 817	854			890	931	971	1012	1052	1092					
		Watts 360	374			387	402	417	433	449	461					
		CFM 1875 [885]	1837 [867]			1799 [849]	1757 [829]	1714 [809]	1674 [790]	1633 [771]	1548 [731]	535				
RLPL-A060 5.0 [17.59]			[06]	1750/2250	10 x 10 1 HP [745] 3 Speed (X-13 Motor)	Low (Tap 1)	CFM 1575 [743]	1536 [725]	1496 [706]	1457 [688]	1417 [669]	1377 [650]	1338 [631]	1298 [613]	1032	
	Med. (Tap 2)	Watts 297	[10] [12]			783	314	330	347	364	381	397	414			
	Med. (Tap 3)	CFM 1985 [937]	1954 [922]			1919 [906]	1876 [885]	1824 [861]	1759 [830]	1679 [792]	1581 [746]	572				
	High (Tap 4)	RPM 902	942			979	1013	1040	1071	1096	1119					
		Watts 535	553			574	593	606	609	599	572					
		CFM 2431 [1147]	2372 [1119]			2306 [1088]	2228 [1051]	2138 [1009]	2032 [959]	1907 [900]	1762 [832]	665				
	RPM 1076	1089	1102	1114	1125	1133	1142	1151								
	Watts 970	981	964	926	872	806	736	665								

[ ] Designates Metric Conversions



## BELT-DRIVE AIRFLOW PERFORMANCE RLNL/RLPL-

Capacity 3 & 3.5 Ton [10.55 & 12.31 kW] Packaged Air Conditioner (13 & 14 SEER)		3 PH—208-230/460 Volt—External Static Pressure—Inches of Water [kPa]																														
		0.1 [.02]		0.2 [.05]		0.3 [.07]		0.4 [.10]		0.5 [.12]		0.6 [.15]		0.7 [.17]		0.8 [.20]		0.9 [.22]		1.0 [.25]		1.1 [.27]		1.2 [.30]		1.3 [.32]		1.4 [.35]		1.5 [.37]		
Air Flow CFM [L/s]	RPM	W	RPM	W	RPM	W	RPM	W	RPM	W	RPM	W	RPM	W	RPM	W	RPM	W	RPM	W	RPM	W	RPM	W	RPM	W	RPM	W	RPM	W		
900 [425]	—	—	665	290	300	730	300	315	830	330	330	360	375	960	390	410	1040	445	1080	470	1140	510	1190	540	1235	590	1300	610	1350	630	1385	660
1000 [472]	—	625	275	680	295	750	310	805	325	850	345	895	375	935	390	970	410	1015	1065	1100	1150	1200	1250	1300	1350	1400	1450	1500	1550	1600	1650	
1100 [519]	—	640	300	710	315	780	325	830	340	875	365	915	390	955	405	990	430	1040	1080	1125	1170	1215	1260	1305	1350	1400	1450	1500	1550	1600	1650	
1200 [566]	—	670	315	735	330	800	345	850	365	890	385	935	410	975	430	1010	1060	1100	1145	1190	1235	1280	1325	1370	1415	1460	1505	1550	1600	1650		
1300 [614]	625	315	700	330	770	350	830	370	875	415	955	440	990	1040	1085	1130	1175	1220	1265	1310	1355	1400	1445	1490	1535	1580	1625	1670	1715	1760		
1400 [661]	655	340	730	365	795	385	850	400	890	430	935	445	975	1010	1050	1090	1130	1170	1210	1250	1290	1330	1370	1410	1450	1490	1530	1570	1610	1650		
1500 [708]	685	380	755	390	825	415	870	435	915	450	955	480	1000	1040	1080	1120	1160	1200	1240	1280	1320	1360	1400	1440	1480	1520	1560	1600	1640	1680		
1600 [755]	730	420	790	435	850	455	890	490	935	505	970	525	1005	1045	1085	1120	1160	1200	1240	1280	1320	1360	1400	1440	1480	1520	1560	1600	1640	1680		
1700 [802]	755	465	825	475	875	505	915	535	955	550	985	570	1040	1080	1120	1160	1200	1240	1280	1320	1360	1400	1440	1480	1520	1560	1600	1640	1680	1720		
1800 [850]	790	500	850	530	890	550	935	570	975	600	1020	650	1080	1120	1160	1200	1240	1280	1320	1360	1400	1440	1480	1520	1560	1600	1640	1680	1720	1760		

Bold lines separate L, M and N drives respectively.

Drive Package	L	M	N (Field-Supplied)
Motor H.P. [W]	1/2 [373]	3/4 [559]	3/4 [559]
Blower Sheave	6.9 Pitch Diameter	6.4 Pitch Diameter	6.4 Pitch Diameter
Motor Sheave	Adjustable 2.4-3.4 Pitch Diameter	Adjustable 3.4-4.4 Pitch Diameter	Adjustable 4.0-5.0 Pitch Diameter
Turns Open	0 1 2 3 4 5 6	0 1 2 3 4 5 6	0 1 2 3 4 5 6
RPM	935 875 830 780 730 680 625 1295 1230 1185 1135 1085 1000 955		RPM Range 1090-1365

### NOTES:

- Performance shown with dry coil & standard 2" [50.8 mm] filters.
- Standard CFM @ .075 lbs./cu. ft.
- Motor efficiency = 80%
- BHP =  $\frac{\text{Watts} \times \text{Motor Eff.}}{746}$
- Add component resistance to duct static to determine E.S.P. as shown on charts.

Capacity 4 Ton [14.06 kW]—Packaged Air Conditioner (13 & 14 SEER)		3 PH—208-230/460 Volt—External Static Pressure—Inches of Water [kPa]																												
		0.1 [.02]		0.2 [.05]		0.3 [.07]		0.4 [.10]		0.5 [.12]		0.6 [.15]		0.7 [.17]		0.8 [.20]		0.9 [.22]		1.0 [.25]		1.1 [.27]		1.2 [.30]		1.3 [.32]		1.4 [.35]		1.5 [.37]
Air Flow CFM [L/s]	RPM	W	RPM	W	RPM	W	RPM	W	RPM	W	RPM	W	RPM	W	RPM	W	RPM	W	RPM	W	RPM	W	RPM	W	RPM	W	RPM	W	RPM	W
1200 [566]	—	—	745	340	810	375	865	390	900	400	945	420	1000	440	1040	460	1075	490	1115	540	1170	580	1215	620	1260	650	1300	685	1350	740
1300 [614]	—	695	330	770	365	835	395	880	415	920	435	975	455	1010	470	1060	490	1100	1150	1200	1250	1300	1350	1400	1450	1500	1550	1600	1650	1700
1400 [661]	—	725	350	795	395	855	420	895	435	945	455	995	470	1030	500	1070	520	1115	1160	1210	1260	1310	1360	1410	1460	1510	1560	1610	1660	1710
1500 [708]	690	360	750	390	820	425	875	450	900	465	970	500	1055	560	1100	580	1140	1180	1230	1280	1330	1380	1430	1480	1530	1580	1630	1680	1730	
1600 [755]	720	390	780	430	850	460	895	480	945	500	1035	565	1075	590	1115	635	1160	1205	1250	1300	1350	1400	1450	1500	1550	1600	1650	1700	1750	
1700 [802]	750	430	810	465	870	485	920	500	970	530	1015	570	1055	600	1090	645	1140	1185	1230	1280	1330	1380	1430	1480	1530	1580	1630	1680	1730	
1800 [850]	780	475	840	515	895	540	945	555	990	600	1035	625	1080	660	1115	710	1155	1200	1250	1300	1350	1400	1450	1500	1550	1600	1650	1700	1750	
1900 [897]	820	520	870	560	925	580	970	600	1015	640	1060	690	1115	750	1145	790	1185	1230	1280	1330	1380	1430	1480	1530	1580	1630	1680	1730	1780	
2000 [944]	850	585	900	610	950	630	1000	665	1045	715	1090	760	1130	810	1170	865	1205	1250	1300	1350	1400	1450	1500	1550	1600	1650	1700	1750	1800	

Bold lines separate L, M and N drives respectively.

Drive Package	L	M	N (Field-Supplied)
Motor H.P. [W]	1/2 [373]	3/4 [559]	3/4 [559]
Blower Sheave	6.9 Pitch Diameter	6.4 Pitch Diameter	6.4 Pitch Diameter
Motor Sheave	Adjustable 2.8-3.8 Pitch Diameter	Adjustable 3.4-4.4 Pitch Diameter	Adjustable 4.0-5.0 Pitch Diameter
Turns Open	0 1 2 3 4 5 6	0 1 2 3 4 5 6	0 1 2 3 4 5 6
RPM	990 945 895 850 800 750 695 1270 1225 1170 1115 1065 1015 965		RPM Range 1090-1365

Factory sheave settings are shown in bold print.

[ ] Designates Metric Conversions

### NOTES:

- Performance shown with dry coil & standard 2" [50.8 mm] filters.
- Standard CFM @ .075 lbs./cu. ft.
- Motor efficiency = 80%
- BHP =  $\frac{\text{Watts} \times \text{Motor Eff.}}{746}$
- Add component resistance to duct static to determine E.S.P. as shown on charts.





## BELT-DRIVE AIRFLOW PERFORMANCE—5 TON [17.58 kW] 14 SEER 3 PHASE MODELS

Capacity		5 Ton [17.6 kW]—Package Air Conditioner (14 SEER)										3 PH—208-230/460 Volt—External Static Pressure—Inches of Water [kPa]																				
Air Flow CFM [L/s]		0.1 [0.02]		0.2 [0.05]		0.3 [0.07]		0.4 [0.10]		0.5 [0.12]		0.6 [0.15]		0.7 [0.17]		0.8 [0.20]		0.9 [0.22]		1.0 [0.25]		1.1 [0.27]		1.2 [0.30]		1.3 [0.32]		1.4 [0.35]		1.5 [0.37]		
RPM	W	RPM	W	RPM	W	RPM	W	RPM	W	RPM	W	RPM	W	RPM	W	RPM	W	RPM	W	RPM	W	RPM	W	RPM	W	RPM	W	RPM	W	RPM	W	
1400 [661]	—	—	—	—	—	—	—	794	395	835	433	877	467	918	499	962	528	1011	556	1085	610	1118	668	1152	723	1187	776	1220	827	1250	876	
1500 [708]	—	—	—	—	—	—	—	810	440	851	478	892	512	934	544	978	573	1026	601	1087	666	1120	724	1154	779	1189	832	1222	883	1252	932	
1600 [755]	—	—	—	789	446	830	489	871	527	913	562	954	593	998	623	1059	668	1090	729	1123	786	1158	842	1193	894	1226	945	1255	995	—	—	
1700 [802]	—	—	—	813	501	854	544	896	582	937	616	979	648	1023	677	1065	736	1096	797	1129	855	1164	910	1199	963	1232	1014	1262	1063	—	—	
1800 [850]	—	—	—	799	470	840	560	882	604	923	642	964	676	1006	708	1044	747	1087	811	1105	872	1139	930	1173	985	1208	1038	1241	1089	1271	1138	
1900 [897]	788	507	828	574	869	625	910	668	952	706	993	741	1035	772	1057	828	1087	892	1118	953	1151	1011	1186	1066	1221	1119	1254	1170	1283	1219	—	—
2000 [944]	817	578	857	644	898	695	939	739	981	777	1022	811	1044	848	1073	916	1103	980	1134	1041	1168	1099	1202	1154	1237	1207	1270	1258	1300	1307	—	—
2100 [991]	845	663	885	720	927	771	968	814	1009	852	1035	869	1064	943	1093	1011	1123	1075	1154	1136	1187	1194	1222	1249	1256	1302	1290	1353	—	—	—	—
2200 [1038]	873	734	913	801	955	852	996	896	1037	934	1057	971	1086	1044	1115	1113	1145	1177	1176	1238	1210	1295	1244	1350	1459	—	—	—	—	—	—	—
2300 [1085]	902	821	942	888	983	939	1024	983	1049	1000	1081	1080	1111	1153	1140	1222	1169	1286	1201	1347	1234	1404	1269	1459	—	—	—	—	—	—	—	—
2400 [1133]	933	914	973	981	1014	1032	1036	1028	1075	1116	1107	1196	1137	1270	1165	1338	1195	1402	1227	1463	—	—	—	—	—	—	—	—	—	—	—	—
2500 [1180]	970	1013	1010	1080	1035	1052	1062	1152	1101	1240	1133	1320	1163	1393	1191	1462	—	—	—	—	—	—	—	—	—	—	—	—	—	—	—	—

NOTE: L-Drive left of bold line, M-Drive right of bold line.

Drive Package	L					M						
	0	1	2	3	4	5	0	1	2	3	4	5
Motor H.P. [w]	3/4 [559]											
Blower Sheave	6.9 Pitch Diameter											
Motor Sheave	Adjustable 2.8-3.8 Pitch Diameter											
Turns Open	Adjustable 4.0-5.0 Pitch Diameter											
RPM	1007	963	<b>922</b>	880	833	785	1272	1242	1210	<b>1172</b>	1130	1089

Factory sheave settings are shown in bold print.

## COMPONENT AIR RESISTANCE

Component	Standard Indoor Airflow—CFM [L/s]					Resistance—Inches Water [kPa]					
	2200 [944]	2400 [1133]	2600 [1227]	2800 [1321]	3200 [1510]	3400 [1605]					
Wet Coil	.079	.090	.102	.118	.128	.135					
Downflow	.061	.079	.089	.100	.108	.112					
R.S.I. Economizer	.09	.10	.11	.12	.13	.15					
R.A. Damper											

### NOTES:

- Performance shown with dry coil & standard 2" [50.8 mm] filters.
- Standard CFM @ .075 lbs./cu. ft.
- Motor efficiency = 80%
- BHP =  $\frac{\text{Watts} \times \text{Motor Eff.}}{746}$
- Add component resistance to duct static to determine E.S.P. as shown on charts.

[ ] Designates Metric Conversions



ELECTRICAL DATA – RLNL SERIES												
		-A036CK	-A036CL	-A036CM	-A036DK	-A036DL	-A036DM	-A036JK	-A036YL	-A036YM	-A042CK	-A042CL
Unit Information	Unit Operating Voltage Range	187-253	187-253	187-253	414-506	414-506	414-506	187-253	517-633	517-633	187-253	187-253
	Minimum Circuit Ampacity	19/19	18/18	18/18	11	10	10	27/27	7	7	23/23	22/22
	Minimum Overcurrent Protection Device Size	25/25	20/20	25/25	15	15	15	35/35	15	15	30/30	25/25
	Maximum Overcurrent Protection Device Size	25/25	25/25	25/25	15	15	15	40/40	15	15	35/35	30/30
Compressor Motor	No.	1	1	1	1	1	1	1	1	1	1	1
	Volts	208/230	208/230	208/230	460	460	460	208/230	575	575	208/230	208/230
	Phase	3	3	3	3	3	3	1	3	3	3	3
	HP	3	3	3	3	3	3	3	3	3	3 1/2	3 1/2
	RPM	3450	3450	3450	3450	3450	3450	3450	3450	3450	3450	3450
	Amps (RLA)	10.4/10.4	10.4/10.4	10.4/10.4	5.8	5.8	5.8	16.7/16.7	3.8	3.8	13.5/13.5	13.5/13.5
	Amps (LRA)	88/88	88/88	88/88	38	38	38	79/79	36.5	36.5	88/88	88/88
Condenser Motor	No.	1	1	1	1	1	1	1	1	1	1	1
	Volts	208/230	208/230	208/230	460	460	460	208/230	575	575	208/230	208/230
	Phase	1	1	1	1	1	1	1	1	1	1	1
	HP	1/3	1/3	1/3	1/3	1/3	1/3	1/3	1/3	1/3	1/3	1/3
	Amps (FLA)	1.5	1.5	1.5	1	1	1	1.5	0.8	0.8	1.5	1.5
	Amps (LRA)	3	3	3	1.9	1.9	1.9	3	1.9	1.9	3	3
Evaporator Fan	No.	1	1	1	1	1	1	1	1	1	1	1
	Volts	208/230	208/230	208/230	460	460	460	208/230	575	575	208/230	208/230
	Phase	1	3	3	1	3	3	1	3	3	1	3
	HP	1/2	1/2	3/4	1/2	1/2	3/4	1/2	3/4	3/4	1/2	1/2
	Amps (FLA)	4	2.8	3.4	2	1.4	1.6	4	1.3	1.3	4	2.8
	Amps (LRA)	6.7	11.3	16.8	3.6	6.2	8.4	6.7	6	6	6.7	11.3

1. Horsepower Per Compressor.
2. Amp Draw Per Motor. Multiply Value By Number of Motors to Determine Total Amps.



ELECTRICAL DATA – RLNL SERIES												
		-A042CM	-A042DK	-A042DL	-A042DM	-A042JK	-A048CK	-A048CL	-A048CM	-A048DK	-A048DL	-A048DM
Unit Information	Unit Operating Voltage Range	187-253	414-506	414-506	414-506	187-253	187-253	187-253	187-253	414-506	414-506	414-506
	Minimum Circuit Ampacity	22/22	11	10	11	28/28	23/23	22/22	23/23	11	11	11
	Minimum Overcurrent Protection Device Size	30/30	15	15	15	35/35	30/30	25/25	30/30	15	15	15
	Maximum Overcurrent Protection Device Size	35/35	15	15	15	45/45	35/35	35/35	35/35	15	15	15
Compressor Motor	No.	1	1	1	1	1	1	1	1	1	1	1
	Volts	208/230	460	460	460	208/230	208/230	208/230	208/230	460	460	460
	Phase	3	3	3	3	1	3	3	3	3	3	3
	HP	3 1/2	3 1/2	3 1/2	3 1/2	3 1/2	4	4	4	4	4	4
	RPM	3450	3450	3450	3450	3450	3450	3450	3450	3450	3450	3450
	Amps (RLA)	13.5/13.5	6	6	6	17.9/17.9	13.7/13.7	13.7/13.7	13.7/13.7	6.2	6.2	6.2
	Amps (LRA)	88/88	44	44	44	112/112	83.1/83.1	83.1/83.1	83.1/83.1	41	41	41
Condenser Motor	No.	1	1	1	1	1	1	1	1	1	1	1
	Volts	208/230	460	460	460	208/230	208/230	208/230	208/230	460	460	460
	Phase	1	1	1	1	1	1	1	1	1	1	1
	HP	1/3	1/3	1/3	1/3	1/3	1/3	1/3	1/3	1/3	1/3	1/3
	Amps (FLA)	1.5	1	1	1	1.5	1.5	1.5	1.5	1	1	1
	Amps (LRA)	3	1.9	1.9	1.9	3	3	3	3	1.9	1.9	1.9
Evaporator Fan	No.	1	1	1	1	1	1	1	1	1	1	1
	Volts	208/230	460	460	460	208/230	208/230	208/230	208/230	460	460	460
	Phase	3	1	3	3	1	1	3	3	1	3	3
	HP	3/4	1/2	1/2	3/4	1/2	1/2	1/2	3/4	1/2	1/2	3/4
	Amps (FLA)	3.4	2	1.4	1.6	4	4	2.8	3.4	2	1.4	1.6
	Amps (LRA)	16.8	3.6	6.2	8.4	6.7	6.7	11.3	16.8	3.6	6.2	8.4

1. Horsepower Per Compressor.
2. Amp Draw Per Motor. Multiply Value By Number of Motors to Determine Total Amps.



ELECTRICAL DATA – RLNL SERIES													
		-A048JK	-A048YL	-A048YM	-A060CK	-A060CL	-A060CM	-A060DK	-A060DL	-A060DM	-A060JK	-A060YL	-A060YM
Unit Information	Unit Operating Voltage Range	187-253	517-633	517-633	187-253	187-253	187-253	414-506	414-506	414-506	187-253	517-633	517-633
	Minimum Circuit Ampacity	33/33	9	9	30/30	26/26	26/26	15	13	13	43/43	10	10
	Minimum Overcurrent Protection Device Size	40/40	15	15	35/35	30/30	30/30	20	15	15	50/50	15	15
	Maximum Overcurrent Protection Device Size	50/50	15	15	40/40	40/40	40/40	20	20	20	60/60	15	15
Compressor Motor	No.	1	1	1	1	1	1	1	1	1	1	1	1
	Volts	208/230	575	575	208/230	208/230	208/230	460	460	460	208/230	575	575
	Phase	1	3	3	3	3	3	3	3	3	1	3	3
	HP	4	4	4	5	5	5	5	5	5	5	5	5
	RPM	3450	3450	3450	3450	3450	3450	3450	3450	3450	3450	3450	3450
	Amps (RLA)	21.8/21.8	4.8	4.8	15.6/15.6	15.6/15.6	15.6/15.6	7.8	7.8	7.8	26.3/26.3	5.8	5.8
	Amps (LRA)	117/117	33	33	110/110	110/110	110/110	52	52	52	134/134	38.9	38.9
Condenser Motor	No.	1	1	1	1	1	1	1	1	1	1	1	1
	Volts	208/230	575	575	208/230	208/230	208/230	460	460	460	208/230	575	575
	Phase	1	1	1	1	1	1	1	1	1	1	1	1
	HP	1/3	1/3	1/3	1/3	1/3	1/3	1/3	1/3	1/3	1/3	1/3	1/3
	Amps (FLA)	1.5	0.8	0.8	2.2	2.2	2.2	1	1	1	2.2	0.8	0.8
	Amps (LRA)	3	1.9	1.9	4.9	4.9	4.9	1.9	1.9	1.9	4.9	1.9	1.9
Evaporator Fan	No.	1	1	1	1	1	1	1	1	1	1	1	1
	Volts	208/230	575	575	208/230	208/230	208/230	460	460	460	208/230	575	575
	Phase	1	3	3	1	3	3	1	3	3	1	3	3
	HP	1/2	3/4	3/4	1	3/4	1	1	3/4	1	1	3/4	1
	Amps (FLA)	4	1.3	1.3	7.6	3.4	3.8	4	1.6	1.9	7.6	1.3	1.4
	Amps (LRA)	6.7	6	6	0	16.8	24	0	8.4	12	0	6	7.2

1. Horsepower Per Compressor.

2. Amp Draw Per Motor. Multiply Value By Number of Motors to Determine Total Amps.



ELECTRICAL DATA – RLPL SERIES										
		-A036CK	-A036CL	-A036CM	-A036DK	-A036DL	-A036DM	-A036JK	-A042CK	-A042CL
Unit Information	Unit Operating Voltage Range	187-253	187-253	187-253	414-506	414-506	414-506	187-253	187-253	187-253
	Minimum Circuit Ampacity	19/19	18/18	18/18	11	10	10	27/27	25/25	22/22
	Minimum Overcurrent Protection Device Size	25/25	20/20	25/25	15	15	15	35/35	30/30	25/25
	Maximum Overcurrent Protection Device Size	25/25	25/25	25/25	15	15	15	40/40	35/35	30/30
Compressor Motor	No.	1	1	1	1	1	1	1	1	1
	Volts	208/230	208/230	208/230	460	460	460	208/230	208/230	208/230
	Phase	3	3	3	3	3	3	1	3	3
	HP	3	3	3	3	3	3	3	3 1/2	3 1/2
	RPM	3450	3450	3450	3450	3450	3450	3450	3450	3450
	Amps (RLA)	10.4/10.4	10.4/10.4	10.4/10.4	5.8	5.8	5.8	16.7/16.7	13.5/13.5	13.5/13.5
	Amps (LRA)	88/88	88/88	88/88	38	38	38	79/79	88/88	88/88
Condenser Motor	No.	1	1	1	1	1	1	1	1	1
	Volts	208/230	208/230	208/230	460	460	460	208/230	208/230	208/230
	Phase	1	1	1	1	1	1	1	1	1
	HP	1/3	1/3	1/3	1/3	1/3	1/3	1/3	1/3	1/3
	Amps (FLA)	1.5	1.5	1.5	1	1	1	1.5	1.5	1.5
	Amps (LRA)	3	3	3	1.9	1.9	1.9	3	3	3
Evaporator Fan	No.	1	1	1	1	1	1	1	1	1
	Volts	208/230	208/230	208/230	460	460	460	208/230	208/230	208/230
	Phase	1	3	3	1	3	3	1	1	3
	HP	1/2	1/2	3/4	1/2	1/2	3/4	1/2	3/4	1/2
	Amps (FLA)	4.1	2.8	3.4	2.1	1.4	1.6	4.1	6	2.8
	Amps (LRA)	0	11.3	16.8	0	6.2	8.4	0	0	11.3

1. Horsepower Per Compressor.
2. Amp Draw Per Motor. Multiply Value By Number of Motors to Determine Total Amps.



ELECTRICAL DATA – RLPL SERIES										
		-A042CM	-A042DK	-A042DL	-A042DM	-A042JK	-A048CK	-A048CL	-A048CM	-A048DK
Unit Information	Unit Operating Voltage Range	187-253	414-506	414-506	414-506	187-253	187-253	187-253	187-253	414-506
	Minimum Circuit Ampacity	22/22	12	10	11	30/30	25/25	22/22	23/23	12
	Minimum Overcurrent Protection Device Size	30/30	15	15	15	35/35	30/30	25/25	30/30	15
	Maximum Overcurrent Protection Device Size	35/35	15	15	15	45/45	35/35	35/35	35/35	15
Compressor Motor	No.	1	1	1	1	1	1	1	1	1
	Volts	208/230	460	460	460	208/230	208/230	208/230	208/230	460
	Phase	3	3	3	3	1	3	3	3	3
	HP	3 1/2	3 1/2	3 1/2	3 1/2	3 1/2	4	4	4	4
	RPM	3450	3450	3450	3450	3450	3450	3450	3450	3450
	Amps (RLA)	13.5/13.5	6	6	6	17.9/17.9	13.7/13.7	13.7/13.7	13.7/13.7	6.2
	Amps (LRA)	88/88	44	44	44	112/112	83.1/83.1	83.1/83.1	83.1/83.1	41
Condenser Motor	No.	1	1	1	1	1	1	1	1	1
	Volts	208/230	460	460	460	208/230	208/230	208/230	208/230	460
	Phase	1	1	1	1	1	1	1	1	1
	HP	1/3	1/3	1/3	1/3	1/3	1/3	1/3	1/3	1/3
	Amps (FLA)	1.5	1	1	1	1.5	1.5	1.5	1.5	1
	Amps (LRA)	3	1.9	1.9	1.9	3	3	3	3	1.9
Evaporator Fan	No.	1	1	1	1	1	1	1	1	1
	Volts	208/230	460	460	460	208/230	208/230	208/230	208/230	460
	Phase	3	1	3	3	1	1	3	3	1
	HP	3/4	3/4	1/2	3/4	3/4	3/4	1/2	3/4	3/4
	Amps (FLA)	3.4	3.2	1.4	1.6	6	6	2.8	3.4	3.2
	Amps (LRA)	16.8	0	6.2	8.4	0	0	11.3	16.8	0

1. Horsepower Per Compressor.
2. Amp Draw Per Motor. Multiply Value By Number of Motors to Determine Total Amps.



ELECTRICAL DATA – RLPL SERIES											
		-A048DL	-A048DM	-A048JK	-A060CK	-A060CL	-A060CM	-A060DK	-A060DL	-A060DM	-A060JK
Unit Information	Unit Operating Voltage Range	414-506	414-506	187-253	187-253	187-253	187-253	414-506	414-506	414-506	187-253
	Minimum Circuit Ampacity	11	11	35/35	30/30	26/26	26/26	15	13	13	43/43
	Minimum Overcurrent Protection Device Size	15	15	45/45	35/35	30/30	35/35	20	15	15	50/50
	Maximum Overcurrent Protection Device Size	15	15	50/50	45/45	40/40	40/40	20	20	20	60/60
Compressor Motor	No.	1	1	1	1	1	1	1	1	1	1
	Volts	460	460	208/230	208/230	208/230	208/230	460	460	460	208/230
	Phase	3	3	1	3	3	3	3	3	3	1
	HP	4	4	4	5	5	5	5	5	5	5
	RPM	3450	3450	3450	3450	3450	3450	3450	3450	3450	3450
	Amps (RLA)	6.2	6.2	21.8/21.8	16/16	16/16	16/16	7.8	7.8	7.8	26.4/26.4
	Amps (LRA)	41	41	117/117	110/110	110/110	110/110	52	52	52	134/134
Condenser Motor	No.	1	1	1	1	1	1	1	1	1	1
	Volts	460	460	208/230	208/230	208/230	208/230	460	460	460	208/230
	Phase	1	1	1	1	1	1	1	1	1	1
	HP	1/3	1/3	1/3	1/3	1/3	1/3	1/3	1/3	1/3	1/3
	Amps (FLA)	1	1	1.5	2.2	2.2	2.2	1	1	1	2.2
	Amps (LRA)	1.9	1.9	3	4.9	4.9	4.9	1.9	1.9	1.9	4.9
Evaporator Fan	No.	1	1	1	1	1	1	1	1	1	1
	Volts	460	460	208/230	208/230	208/230	208/230	460	460	460	208/230
	Phase	3	3	1	1	3	3	1	3	3	1
	HP	1/2	3/4	3/4	1	3/4	1	1	3/4	1	1
	Amps (FLA)	1.4	1.6	6	7.6	3.4	3.8	4	1.6	1.9	7.6
	Amps (LRA)	6.2	8.4	0	0	16.8	24	0	8.4	12	0

1. Horsepower Per Compressor.
2. Amp Draw Per Motor. Multiply Value By Number of Motors to Determine Total Amps.



# UNITS WITH HEATER KITS—RLNL- SERIES

208-240 VOLT, THREE PHASE, 60 HZ, AUXILIARY ELECTRIC HEATER KITS CHARACTERISTICS AND APPLICATION												
Model No. RLNL-	RXJJ- Heater Kit Nominal kW	Rated Heater kW @ 208/240 V	Heater KBTU/Hr @ 208/240 V	Heater Amp. @ 208/240 V	Unit Min. Ckt. Ampacity @ 208/240 V	Over Current Protective Device Size		Separate Power Supply For Both Unit and Heater Kit				
						Min./Max. @ 208 V	Min./Max. @ 240 V	Heater Kit Min. Ckt. Ampacity 208/240 V	Heater Kit Max. Fuse Size 208/240 V	Air Cond. Min. Ckt. Ampacity 208/240 V	Air Cond. Protective Device Size Min./Max. @ 208 V	Air Cond. Over Current Protective Device Size Min./Max. @ 240 V
A036CK	No Heat	—	—	—	19/19	25/25	25/25	—	—	19/19	25/25	25/25
	A06C+	4.2/5.6	14.33/19.10	11.7/13.5	20/22	25/25	25/25	15/17	15/20	—	—	—
	A10C+	7.2/9.6	24.56/32.75	20.0/23.1	30/34	30/30	35/35	25/29	25/30	—	—	—
	*A11C+	7.2/9.6	24.56/32.75	20.0/23.1	30/34	30/30	35/35	25/29	25/30	—	—	—
	A12C+	8.4/11.2	28.66/38.21	23.4/27.0	35/39	35/35	40/40	30/34	30/35	—	—	—
	A15C+	10.8/14.4	36.84/49.13	30.1/34.7	43/49	45/45	50/50	38/44	40/45	—	—	—
A042CK	A20C+	14.4/19.2	49.13/65.50	40.1/46.2	56/63	60/60	70/70	51/58	60/60	—	—	—
	*A21C+	14.4/19.2	49.13/65.50	40.1/46.2	56/63	60/60	70/70	51/58	60/60	—	—	—
	No Heat	—	—	—	23/23	30/35	30/35	—	—	23/23	30/35	30/35
	A06C+	4.2/5.6	14.33/19.10	11.7/13.5	23/23	30/35	30/35	15/17	15/20	—	—	—
	A10C+	7.2/9.6	24.56/32.75	20.0/23.1	30/34	30/35	35/35	25/29	25/30	—	—	—
	*A11C+	7.2/9.6	24.56/32.75	20.0/23.1	30/34	30/35	35/35	25/29	25/30	—	—	—
A048CK	A12C+	8.4/11.2	28.66/38.21	23.4/27.0	35/39	35/35	40/40	30/34	30/35	—	—	—
	A15C+	10.8/14.4	36.84/49.13	30.1/34.7	43/49	45/45	50/50	38/44	40/45	—	—	—
	A20C+	14.4/19.2	49.13/65.50	40.1/46.2	56/63	60/60	70/70	51/58	60/60	—	—	—
	*A21C+	14.4/19.2	49.13/65.50	40.1/46.2	56/63	60/60	70/70	51/58	60/60	—	—	—
	No Heat	—	—	—	23/23	30/35	30/35	—	—	23/23	30/35	30/35
	A06C+	4.2/5.6	14.33/19.10	11.7/13.5	23/23	30/35	30/35	15/17	15/20	—	—	—
A060CK	A10C+	7.2/9.6	24.56/32.75	20.0/23.1	30/34	30/35	35/35	25/29	25/30	—	—	—
	*A11C+	7.2/9.6	24.56/32.75	20.0/23.1	35/39	35/40	40/40	25/29	25/30	—	—	—
	A12C+	8.4/11.2	28.66/38.21	23.4/27.0	39/44	40/40	45/45	30/34	30/35	—	—	—
	A15C+	10.8/14.4	36.84/49.13	30.1/34.7	48/53	50/50	60/60	38/44	40/45	—	—	—
	A20C+	14.4/19.2	49.13/65.50	40.1/46.2	60/68	60/60	70/70	51/58	60/60	—	—	—
	*A21C+	14.4/19.2	49.13/65.50	40.1/46.2	60/68	60/60	70/70	51/58	60/60	—	—	—

\*= For Canadian use only. Uses "P" fuses for inductive circuit.  
 += Field installed only.



208-240 VOLT, THREE PHASE, 60 HZ, AUXILIARY ELECTRIC HEATER KITS CHARACTERISTICS AND APPLICATION												
Single Power Supply For Both Unit and Heater Kit						Separate Power Supply For Both Unit and Heater Kit						
Model No. RLNL-	RXJ- Heater Kit Nominal kW	Rated Heater kW @ 208/240 V	Heater KBTU/Hr @ 208/240 V	Heater Amp. @ 208/240 V	Unit Min. Ckt. Ampacity @ 208/240 V	Over Current Protective Device Size		Heater Kit Min. Ckt. Ampacity 208/240 V	Heater Kit Max. Fuse Size 208/240 V	Air Cond. Min. Ckt. Ampacity 208/240 V	Air Cond. Over Current Protective Device Size	
						Min. @ 208 V	Max. @ 240 V				Min. @ 208 V	Max. @ 240 V
A036CL	No Heat	—	—	—	18/18	20/25	20/25	—	—	18/18	20/25	20/25
	A06C+	4.2/5.6	14.33/19.10	11.7/13.5	19/21	20/25	25/30	15/17	15/20	—	—	—
	A10C+	7.2/9.6	24.56/32.75	20.0/23.1	29/33	30/30	35/35	25/29	25/30	—	—	—
	*A11C+	7.2/9.6	24.56/32.75	20.0/23.1	29/33	30/30	35/35	25/29	25/30	—	—	—
	A12C+	8.4/11.2	28.66/38.21	23.4/27.0	33/38	35/35	40/40	30/34	30/35	—	—	—
	A15C+	10.8/14.4	36.84/49.13	30.1/34.7	42/47	45/45	50/50	38/44	40/45	—	—	—
A042CL	A20C+	14.4/19.2	49.13/65.50	40.1/46.2	54/62	60/60	70/70	51/58	60/60	—	—	—
	*A21C+	14.4/19.2	49.13/65.50	40.1/46.2	54/62	60/60	70/70	51/58	60/60	—	—	—
	No Heat	—	—	—	22/22	25/30	25/30	—	—	22/22	25/30	25/30
	A06C+	4.2/5.6	14.33/19.10	11.7/13.5	22/22	25/30	25/30	15/17	15/20	—	—	—
	A10C+	7.2/9.6	24.56/32.75	20.0/23.1	29/33	30/30	35/35	25/29	25/30	—	—	—
	*A11C+	7.2/9.6	24.56/32.75	20.0/23.1	29/33	30/30	35/35	25/29	25/30	—	—	—
A048CL	A12C+	8.4/11.2	28.66/38.21	23.4/27.0	33/38	35/35	40/40	30/34	30/35	—	—	—
	A15C+	10.8/14.4	36.84/49.13	30.1/34.7	42/47	45/45	50/50	38/44	40/45	—	—	—
	A20C+	14.4/19.2	49.13/65.50	40.1/46.2	54/62	60/60	70/70	51/58	60/60	—	—	—
	*A21C+	14.4/19.2	49.13/65.50	40.1/46.2	54/62	60/60	70/70	51/58	60/60	—	—	—
	No Heat	—	—	—	22/22	25/35	25/35	—	—	22/22	25/35	25/35
	A06C+	4.2/5.6	14.33/19.10	11.7/13.5	22/22	25/35	25/35	15/17	15/20	—	—	—
A060CL	A10C+	7.2/9.6	24.56/32.75	20.0/23.1	29/33	30/35	35/35	25/29	25/30	—	—	—
	*A11C+	7.2/9.6	24.56/32.75	20.0/23.1	29/33	30/35	35/35	25/29	25/30	—	—	—
	A12C+	8.4/11.2	28.66/38.21	23.4/27.0	33/38	35/35	40/40	30/34	30/35	—	—	—
	A15C+	10.8/14.4	36.84/49.13	30.1/34.7	42/48	45/45	50/50	38/44	40/45	—	—	—
	A20C+	14.4/19.2	49.13/65.50	40.1/46.2	55/62	60/60	70/70	51/58	60/60	—	—	—
	*A21C+	14.4/19.2	49.13/65.50	40.1/46.2	55/62	60/60	70/70	51/58	60/60	—	—	—
A24C+	A24C+	18.0/24.0	61.41/81.88	50.1/57.8	67/77	70/70	80/80	63/73	70/80	—	—	—
	No Heat	—	—	—	26/26	30/40	30/40	—	—	26/26	30/40	30/40
	A06C+	4.2/5.6	14.33/19.10	11.7/13.5	26/26	30/40	30/40	15/17	15/20	—	—	—
	A10C+	7.2/9.6	24.56/32.75	20.0/23.1	30/34	30/40	35/40	25/29	25/30	—	—	—
	*A11C+	7.2/9.6	24.56/32.75	20.0/23.1	30/34	30/40	35/40	25/29	25/30	—	—	—
	A12C+	8.4/11.2	28.66/38.21	23.4/27.0	34/38	35/40	40/40	30/34	30/35	—	—	—

\*= For Canadian use only. Uses "P" fuses for inductive circuit.  
+ = Field installed only.



# UNITS WITH HEATER KITS—RLNL- SERIES

208-240 VOLT, THREE PHASE, 60 HZ, AUXILIARY ELECTRIC HEATER KITS CHARACTERISTICS AND APPLICATION												
Separate Power Supply For Both Unit and Heater Kit												
Model No. RLNL-	RXJ- Heater Kit Nominal kW	Rated Heater kW @ 208/240 V	Heater KBTU/Hr @ 208/240 V	Heater Amp. @ 208/240 V	Unit Min. Ckt. Ampacity @ 208/240 V	Over Current Protective Device Size		Heater Kit Min. Ckt. Ampacity 208/240 V	Heater Kit Max. Fuse Size 208/240 V	Air Cond. Min. Ckt. Ampacity 208/240 V	Air Cond. Over Current Protective Device Size	
						Min. @ 208 V	Max. @ 240 V				Min. @ 208 V	Max. @ 240 V
A036CM	No Heat	—	—	—	18/18	25/25	25/25	—	—	18/18	25/25	25/25
	A06C+	4.2/5.6	14.33/19.10	11.7/13.5	19/22	25/25	25/25	15/17	15/20	—	—	—
	A10C+	7.2/9.6	24.56/32.75	20.0/23.1	30/34	30/30	35/35	25/29	25/30	—	—	—
	*A11C+	7.2/9.6	24.56/32.75	20.0/23.1	30/34	30/30	35/35	25/29	25/30	—	—	—
	A12C+	8.4/11.2	28.66/38.21	23.4/27.0	34/38	35/35	40/40	30/34	30/35	—	—	—
	A15C+	10.8/14.4	36.84/49.13	30.1/34.7	42/48	45/45	50/50	38/44	40/45	—	—	—
A042CM	A20C+	14.4/19.2	49.13/65.50	40.1/46.2	55/62	60/60	70/70	51/58	60/60	—	—	—
	*A21C+	14.4/19.2	49.13/65.50	40.1/46.2	55/62	60/60	70/70	51/58	60/60	—	—	—
	No Heat	—	—	—	22/22	30/35	30/35	—	—	22/22	30/35	30/35
	A06C+	4.2/5.6	14.33/19.10	11.7/13.5	22/22	30/35	30/35	15/17	15/20	—	—	—
	A10C+	7.2/9.6	24.56/32.75	20.0/23.1	30/34	30/35	35/35	25/29	25/30	—	—	—
	*A11C+	7.2/9.6	24.56/32.75	20.0/23.1	30/34	30/35	35/35	25/29	25/30	—	—	—
A048CM	A12C+	8.4/11.2	28.66/38.21	23.4/27.0	34/38	35/35	40/40	30/34	30/35	—	—	—
	A15C+	10.8/14.4	36.84/49.13	30.1/34.7	42/48	45/45	50/50	38/44	40/45	—	—	—
	A20C+	14.4/19.2	49.13/65.50	40.1/46.2	55/62	60/60	70/70	51/58	60/60	—	—	—
	*A21C+	14.4/19.2	49.13/65.50	40.1/46.2	55/62	60/60	70/70	51/58	60/60	—	—	—
	No Heat	—	—	—	23/23	30/35	30/35	—	—	23/23	30/35	30/35
	A06C+	4.2/5.6	14.33/19.10	11.7/13.5	23/23	30/35	30/35	15/17	15/20	—	—	—
A060CM	A10C+	7.2/9.6	24.56/32.75	20.0/23.1	30/34	30/35	35/35	25/29	25/30	—	—	—
	*A11C+	7.2/9.6	24.56/32.75	20.0/23.1	30/34	30/35	35/35	25/29	25/30	—	—	—
	A12C+	8.4/11.2	28.66/38.21	23.4/27.0	34/38	35/35	40/40	30/34	30/35	—	—	—
	A15C+	10.8/14.4	36.84/49.13	30.1/34.7	42/48	45/45	50/50	38/44	40/45	—	—	—
	A20C+	14.4/19.2	49.13/65.50	40.1/46.2	55/62	60/60	70/70	51/58	60/60	—	—	—
	*A21C+	14.4/19.2	49.13/65.50	40.1/46.2	55/62	60/60	70/70	51/58	60/60	—	—	—
A060CM	No Heat	—	—	—	26/26	30/40	30/40	—	—	26/26	30/40	30/40
	A06C+	4.2/5.6	14.33/19.10	11.7/13.5	26/26	30/40	30/40	15/17	15/20	—	—	—
	A10C+	7.2/9.6	24.56/32.75	20.0/23.1	30/34	30/40	35/40	25/29	25/30	—	—	—
	*A11C+	7.2/9.6	24.56/32.75	20.0/23.1	30/34	30/40	35/40	25/29	25/30	—	—	—
	A12C+	8.4/11.2	28.66/38.21	23.4/27.0	34/39	35/40	40/40	30/34	30/35	—	—	—
	A15C+	10.8/14.4	36.84/49.13	30.1/34.7	43/49	45/45	50/50	38/44	40/45	—	—	—
A060CM	A20C+	14.4/19.2	49.13/65.50	40.1/46.2	55/63	60/60	70/70	51/58	60/60	—	—	—
	*A21C+	14.4/19.2	49.13/65.50	40.1/46.2	55/63	60/60	70/70	51/58	60/60	—	—	—
	A24C+	18.0/24.0	61.41/81.88	50.1/57.8	68/77	70/70	80/80	63/73	70/80	—	—	—

\*= For Canadian use only. Uses "P" fuses for inductive circuit.  
+ = Field installed only.

# UNITS WITH HEATER KITS—RLNL- SERIES



460 VOLT, THREE PHASE, 60 HZ, AUXILIARY ELECTRIC HEATER KITS CHARACTERISTICS AND APPLICATION												
Single Power Supply For Both Unit and Heater Kit						Separate Power Supply For Both Unit and Heater Kit						
Model No. RLNL-	RXJJ-Heater Kit Nominal kW	Rated Heater kW @ 460 V	Heater KBTU/Hr @ 460 V	Heater Amp. @ 460 V	Unit Min. Ckt. Ampacity @ 460 V	Over Current Protective Device Size @ 460 V		Heater Kit Min. Ckt. Ampacity @ 460 V	Heater Kit Max. Fuse Size @ 460 V	Air Cond. Min. Ckt. Ampacity @ 460 V	Air Cond. Over Current Protective Device Size @ 460 V	
						Min./Max.	Min./Max.				Min./Max.	Min./Max.
A036DK	No Heat	—	—	—	11	15/15	—	—	—	11	15/15	—
	A06D+	5.6	19.10	6.7	11	15/15	—	9	15	—	—	—
	A10D+	9.6	32.75	11.6	17	20/20	—	15	15	—	—	—
	*A11D+	9.6	32.75	11.6	17	20/20	—	15	15	—	—	—
	A12D+	11.2	38.21	13.5	20	20/20	—	17	20	—	—	—
	A15D+	14.4	49.13	17.3	25	25/25	—	22	25	—	—	—
A042DK	A20D+	19.2	65.50	23.1	32	35/35	—	29	30	—	—	—
	*A21D+	19.2	65.50	23.1	32	35/35	—	29	30	—	—	—
	No Heat	—	—	—	11	15/15	—	—	—	11	15/15	—
	A06D+	5.6	19.10	6.7	11	15/15	—	9	15	—	—	—
	A10D+	9.6	32.75	11.6	17	20/20	—	15	15	—	—	—
	*A11D+	9.6	32.75	11.6	17	20/20	—	15	15	—	—	—
A048DK	A12D+	11.2	38.21	13.5	20	20/20	—	17	20	—	—	—
	A15D+	14.4	49.13	17.3	25	25/25	—	22	25	—	—	—
	A20D+	19.2	65.50	23.1	32	35/35	—	29	30	—	—	—
	*A21D+	19.2	65.50	23.1	32	35/35	—	29	30	—	—	—
	No Heat	—	—	—	11	15/15	—	—	—	11	15/15	—
	A06D+	5.6	19.10	6.7	11	15/15	—	9	15	—	—	—
A060DK	A10D+	9.6	32.75	11.6	17	20/20	—	15	15	—	—	—
	*A11D+	9.6	32.75	11.6	20	20/20	—	15	15	—	—	—
	A12D+	11.2	38.21	13.5	22	25/25	—	17	20	—	—	—
	A15D+	14.4	49.13	17.4	27	25/30	—	22	25	—	—	—
	A20D+	19.2	65.50	23.3	35	35/35	—	29	30	—	—	—
	*A21D+	19.2	65.50	23.3	35	35/35	—	29	30	—	—	—
A24D+	24.0	81.88	28.9	42	45/45	—	37	40	—	—	—	

\*= For Canadian use only. Uses "P" fuses for inductive circuit.  
+ = Field installed only.



# UNITS WITH HEATER KITS—RLNL- SERIES

## 460 VOLT, THREE PHASE, 60 HZ, AUXILIARY ELECTRIC HEATER KITS CHARACTERISTICS AND APPLICATION

Model No. RLNL-	Single Power Supply For Both Unit and Heater Kit										Separate Power Supply For Both Unit and Heater Kit					
	RXJJ- Heater Kit Nominal kW	Rated Heater kW @ 460 V	Heater KBTU/Hr @ 460 V	Heater Amp. @ 460 V	Unit Min. Ckt. Ampacity @ 460 V	Over Current Protective Device Size @ 460 V		Heater Kit Min. Ckt. Ampacity @ 460 V	Heater Kit Max. Fuse Size @ 460 V	Air Cond. Min. Ckt. Ampacity @ 460 V	Air Cond. Over Current Protective Device Size @ 460 V					
						Min. @ 460 V	Max. @ 460 V				Min. @ 460 V	Max. @ 460 V				
A036DL	No Heat	—	—	—	10	15/15	—	—	—	10	15/15	—				
	A06D+	5.6	19.10	6.7	11	15/15	—	—	—	—	—	—				
	A10D+	9.6	32.75	11.6	17	20/20	—	—	—	—	—	—				
	*A11D+	9.6	32.75	11.6	17	20/20	—	—	—	—	—	—				
	A12D+	11.2	38.21	13.5	19	20/20	—	—	—	—	—	—				
	A15D+	14.4	49.13	17.3	24	25/25	—	—	—	—	—	—				
A042DL	A20D+	19.2	65.50	23.1	31	35/35	—	—	—	—	—	—				
	*A21D+	19.2	65.50	23.1	31	35/35	—	—	—	—	—	—				
	No Heat	—	—	—	10	15/15	—	—	—	10	15/15	—				
	A06D+	5.6	19.10	6.7	11	15/15	—	—	—	—	—	—				
	A10D+	9.6	32.75	11.6	17	20/20	—	—	—	—	—	—				
	*A11D+	9.6	32.75	11.6	17	20/20	—	—	—	—	—	—				
A048DL	A12D+	11.2	38.21	13.5	19	20/20	—	—	—	—	—	—				
	A15D+	14.4	49.13	17.3	24	25/25	—	—	—	—	—	—				
	A20D+	19.2	65.50	23.1	31	35/35	—	—	—	—	—	—				
	*A21D+	19.2	65.50	23.1	31	35/35	—	—	—	—	—	—				
	No Heat	—	—	—	11	15/15	—	—	—	11	15/15	—				
	A06D+	5.6	19.10	6.7	11	15/15	—	—	—	—	—	—				
A060DL	A10D+	9.6	32.75	11.6	17	20/20	—	—	—	—	—	—				
	*A11D+	9.6	32.75	11.6	17	20/20	—	—	—	—	—	—				
	A12D+	11.2	38.21	13.5	19	20/20	—	—	—	—	—	—				
	A15D+	14.4	49.13	17.3	24	25/25	—	—	—	—	—	—				
	A20D+	19.2	65.50	23.1	31	35/35	—	—	—	—	—	—				
	*A21D+	19.2	65.50	23.1	31	35/35	—	—	—	—	—	—				
A064DL	No Heat	—	—	—	13	15/20	—	—	—	13	15/20	—				
	A06D+	5.6	19.10	6.7	13	15/20	—	—	—	—	—	—				
	A10D+	9.6	32.75	11.6	17	20/20	—	—	—	—	—	—				
	*A11D+	9.6	32.75	11.6	17	20/20	—	—	—	—	—	—				
	A12D+	11.2	38.21	13.5	19	20/20	—	—	—	—	—	—				
	A15D+	14.4	49.13	17.3	24	25/25	—	—	—	—	—	—				
A068DL	A20D+	19.2	65.50	23.1	31	35/35	—	—	—	—	—	—				
	*A21D+	19.2	65.50	23.1	31	35/35	—	—	—	—	—	—				
	No Heat	—	—	—	13	15/20	—	—	—	13	15/20	—				
	A06D+	5.6	19.10	6.7	13	15/20	—	—	—	—	—	—				
	A10D+	9.6	32.75	11.6	17	20/20	—	—	—	—	—	—				
	*A11D+	9.6	32.75	11.6	17	20/20	—	—	—	—	—	—				
A072DL	A12D+	11.2	38.21	13.5	19	20/20	—	—	—	—	—	—				
	A15D+	14.4	49.13	17.3	24	25/25	—	—	—	—	—	—				
	A20D+	19.2	65.50	23.1	31	35/35	—	—	—	—	—	—				
	*A21D+	19.2	65.50	23.1	31	35/35	—	—	—	—	—	—				
	No Heat	—	—	—	13	15/20	—	—	—	13	15/20	—				
	A06D+	5.6	19.10	6.7	13	15/20	—	—	—	—	—	—				
A076DL	A10D+	9.6	32.75	11.6	17	20/20	—	—	—	—	—	—				
	*A11D+	9.6	32.75	11.6	17	20/20	—	—	—	—	—	—				
	A12D+	11.2	38.21	13.5	19	20/20	—	—	—	—	—	—				
	A15D+	14.4	49.13	17.3	24	25/25	—	—	—	—	—	—				
	A20D+	19.2	65.50	23.1	31	35/35	—	—	—	—	—	—				
	*A21D+	19.2	65.50	23.1	31	35/35	—	—	—	—	—	—				
A080DL	A24D+	24.0	81.88	28.9	39	40/40	—	—	—	—	—	—				
	No Heat	—	—	—	13	15/20	—	—	—	13	15/20	—				
	A06D+	5.6	19.10	6.7	13	15/20	—	—	—	—	—	—				
	A10D+	9.6	32.75	11.6	17	20/20	—	—	—	—	—	—				
	*A11D+	9.6	32.75	11.6	17	20/20	—	—	—	—	—	—				
	A12D+	11.2	38.21	13.5	19	20/20	—	—	—	—	—	—				

\*= For Canadian use only. Uses "p" fuses for inductive circuit.

+ = Field installed only.

# UNITS WITH HEATER KITS—RLNL- SERIES



460 VOLT, THREE PHASE, 60 HZ, AUXILIARY ELECTRIC HEATER KITS CHARACTERISTICS AND APPLICATION													
Model No. RLNL-	RXJJ- Heater Kit Nominal kW	Rated Heater kW @ 460 V	Heater KBTU/Hr @ 460 V	Heater Amp. @ 460 V	Unit Min. Ckt. Ampacity @ 460 V	Over Current Protective Device Size		Separate Power Supply For Both Unit and Heater Kit					
						Min./Max. @ 460 V	Min./Max. @ 460 V	Heater Kit Min. Ckt. Ampacity 460 V	Heater Kit Max. Fuse Size 460 V	Air Cond. Min. Ckt. Ampacity @ 460 V	Air Cond. Over Current Protective Device Size		
											Min./Max. @ 460 V	Min./Max. @ 460 V	
A036DM	No Heat	—	—	—	10	15/15	—	—	—	10	—	15/15	—
	A06D+	5.6	19.10	6.7	11	15/15	—	—	9	15	—	—	—
	A10D+	9.6	32.75	11.6	17	20/20	20/20	—	15	15	—	—	—
	*A11D+	9.6	32.75	11.6	17	20/20	20/20	—	15	15	—	—	—
	A12D+	11.2	38.21	13.5	19	20/20	20/20	—	17	20	—	—	—
	A15D+	14.4	49.13	17.3	24	25/25	25/25	—	22	25	—	—	—
A042DM	A20D+	19.2	65.50	23.1	31	35/35	—	—	29	30	—	—	—
	*A21D+	19.2	65.50	23.1	31	35/35	—	—	29	30	—	—	—
	No Heat	—	—	—	11	15/15	—	—	—	11	—	15/15	—
	A06D+	5.6	19.10	6.7	11	15/15	—	—	9	15	—	—	—
	A10D+	9.6	32.75	11.6	17	20/20	20/20	—	15	15	—	—	—
	*A11D+	9.6	32.75	11.6	17	20/20	20/20	—	15	15	—	—	—
A048DM	A12D+	11.2	38.21	13.5	19	20/20	—	—	17	20	—	—	—
	A15D+	14.4	49.13	17.3	24	25/25	—	—	22	25	—	—	—
	A20D+	19.2	65.50	23.1	31	35/35	—	—	29	30	—	—	—
	*A21D+	19.2	65.50	23.1	31	35/35	—	—	29	30	—	—	—
	No Heat	—	—	—	11	15/15	—	—	—	11	—	15/15	—
	A06D+	5.6	19.10	6.7	11	15/15	—	—	9	15	—	—	—
A060DM	A10D+	9.6	32.75	11.6	17	20/20	—	—	15	15	—	—	—
	*A11D+	9.6	32.75	11.6	17	20/20	—	—	15	15	—	—	—
	A12D+	11.2	38.21	13.5	20	20/20	—	—	17	20	—	—	—
	A15D+	14.4	49.13	17.3	24	25/25	—	—	22	25	—	—	—
	A20D+	19.2	65.50	23.1	32	35/35	—	—	29	30	—	—	—
	*A21D+	19.2	65.50	23.1	32	35/35	—	—	29	30	—	—	—
A066DM	A24D+	24.0	81.88	28.9	39	40/40	—	—	37	40	—	—	—
	No Heat	—	—	—	13	15/20	—	—	—	13	—	15/20	—
	A06D+	5.6	19.10	6.7	13	15/20	—	—	9	15	—	—	—
	A10D+	9.6	32.75	11.6	17	20/20	20/20	—	15	15	—	—	—
	*A11D+	9.6	32.75	11.6	17	20/20	20/20	—	15	15	—	—	—
	A12D+	11.2	38.21	13.5	20	20/20	20/20	—	17	20	—	—	—

\*= For Canadian use only. Uses "P" fuses for inductive circuit.  
+ = Field installed only.



# UNITS WITH HEATER KITS—RLNL- SERIES

208-240 VOLT, SINGLE PHASE, 60 HZ, AUXILIARY ELECTRIC HEATER KITS CHARACTERISTICS AND APPLICATION												
		Single Power Supply For Both Unit and Heater Kit						Separate Power Supply For Both Unit and Heater Kit				
Model No. RLNL-	RXJ-Heater Kit Nominal kW	Rated Heater kW @ 208/240 V	Heater KBTU/Hr @ 208/240 V	Heater Amp. @ 208/240 V	Unit Min. Ckt. Ampacity @ 208/240 V	Over Current Protective Device Size		Heater Kit Min. Ckt. Ampacity 208/240 V	Heater Kit Max. Fuse Size 208/240 V	Air Cond. Min. Ckt. Ampacity @ 208/240 V	Air Cond. Over Current Protective Device Size	
						Min./Max. @ 208 V	Min./Max. @ 240 V				Min./Max. @ 208 V	Min./Max. @ 240 V
A036JK	No Heat	—	—	—	27/27	35/40	35/40	—	—	27/27	35/40	35/40
	A06J+	4.2/5.6	14.33/19.10	20.2/23.3	31/35	35/40	35/40	26/30	30/30	—	—	—
	A10J+	7.2/9.6	24.56/32.75	34.7/40.0	49/55	50/50	60/60	44/50	45/50	—	—	—
	*A11J+	7.2/9.6	24.56/32.75	34.7/40.0	49/55	50/50	60/60	44/50	45/50	—	—	—
	A12J+	8.4/11.2	28.66/38.21	40.4/46.7	56/64	60/60	70/70	51/59	60/60	—	—	—
	A15J+	10.8/14.4	36.84/49.13	52.0/60.0	70/80	80/80	80/80	65/75	70/80	—	—	—
A042JK	A20J+	14.4/19.2	49.13/65.50	69.3/80.0	92/105	100/100	110/110	87/100	90/100	—	—	—
	*A21J+	14.4/19.2	49.13/65.50	69.3/80.0	92/105	100/100	110/110	87/100	90/100	—	—	—
	No Heat	—	—	—	28/28	35/45	35/45	—	—	28/28	35/45	35/45
	A06J+	4.2/5.6	14.33/19.10	20.2/23.3	31/35	35/45	35/45	26/30	30/30	—	—	—
	A10J	7.2/9.6	24.56/32.75	34.7/40.0	49/55	50/50	60/60	44/50	45/50	—	—	—
	*A11J+	7.2/9.6	24.56/32.75	34.7/40.0	49/55	50/50	60/60	44/50	45/50	—	—	—
A048JK	A12J+	8.4/11.2	28.66/38.21	40.4/46.7	56/64	60/60	70/70	51/59	60/60	—	—	—
	A15J	10.8/14.4	36.84/49.13	52.0/60.0	70/80	80/80	80/80	65/75	70/80	—	—	—
	A20J	14.4/19.2	49.13/65.50	69.3/80.0	92/105	100/100	110/110	87/100	90/100	—	—	—
	*A21J+	14.4/19.2	49.13/65.50	69.3/80.0	92/105	100/100	110/110	87/100	90/100	—	—	—
	No Heat	—	—	—	33/33	40/50	40/50	—	—	33/33	40/50	40/50
	A06J+	4.2/5.6	14.33/19.10	20.2/23.3	33/35	40/50	40/50	26/30	30/30	—	—	—
A060JK	A10J+	7.2/9.6	24.56/32.75	34.7/40.0	49/55	50/50	60/60	44/50	45/50	—	—	—
	*A11J+	7.2/9.6	24.56/32.75	34.7/40.0	49/55	50/50	60/60	44/50	45/50	—	—	—
	A12J+	8.4/11.2	28.66/38.21	40.4/46.7	56/64	60/60	70/70	51/59	60/60	—	—	—
	A15J	10.8/14.4	36.84/49.13	52.0/60.0	70/80	80/80	80/80	65/75	70/80	—	—	—
	A20J	14.4/19.2	49.13/65.50	69.3/80.0	92/105	100/100	110/110	87/100	90/100	—	—	—
	*A21J+	14.4/19.2	49.13/65.50	69.3/80.0	92/105	100/100	110/110	87/100	90/100	—	—	—

\*= For Canadian use only. Uses "rp" fuses for inductive circuit.  
+ = Field installed only.

# UNITS WITH HEATER KITS—RLPL- SERIES



## 208-240 VOLT, THREE PHASE, 60 HZ, AUXILIARY ELECTRIC HEATER KITS CHARACTERISTICS AND APPLICATION

Model No. RLPL-	Single Power Supply For Both Unit and Heater Kit										Separate Power Supply For Both Unit and Heater Kit					
	RXJJ- Heater Kit Nominal KW	Rated Heater KW @ 208/240 V	Heater KBTU/Hr @ 208/240 V	Heater Amp. @ 208/240 V	Unit Min. Ckt. Ampacity @ 208/240 V	Over Current Protective Device Size @ 240 V		Heater Kit Min. Ckt. Ampacity 208/240 V	Heater Kit Max. Fuse Size 208/240 V	Air Cond. Min. Ckt. Ampacity 208/240 V	Air Cond. Over Current Protective Device Size @ 240 V					
						Min./Max. @ 208 V	Min./Max. @ 240 V				Min./Max. @ 208 V	Min./Max. @ 240 V				
A036CK	NONE*	—	—	—	19/19	25/25	25/25	—	—	19/19	25/25	25/25				
	A06C+	4.2/5.6	14.33/19.10	11.7/13.5	20/22	25/25	25/25	15/20	—	—	—	—				
	A10C+	7.2/9.6	24.56/32.75	20.0/23.1	31/34	35/35	35/35	25/30	—	—	—	—				
	*A11C+	7.2/9.6	24.56/32.75	20.0/23.1	31/34	35/35	35/35	25/29	—	—	—	—				
	A12C+	8.4/11.2	28.66/38.21	23.4/27.0	35/39	40/40	40/40	30/34	—	—	—	—				
	A15C+	10.8/14.4	36.84/49.13	30.1/34.7	43/49	45/45	50/50	38/44	—	—	—	—				
A20C+	14.4/19.2	49.13/65.50	40.1/46.2	56/63	60/60	70/70	51/58	—	—	—	—					
*A21C+	14.4/19.2	49.13/65.50	40.1/46.2	56/63	60/60	70/70	51/58	—	—	—	—					
A042CK	NONE*	—	—	—	25/25	30/35	30/35	—	—	25/25	30/35	30/35				
	A06C+	4.2/5.6	14.33/19.10	11.7/13.5	25/25	30/35	30/35	15/20	—	—	—	—				
	A10C+	7.2/9.6	24.56/32.75	20.0/23.1	33/37	35/35	40/40	25/30	—	—	—	—				
	*A11C+	7.2/9.6	24.56/32.75	20.0/23.1	33/37	35/35	40/40	25/29	—	—	—	—				
	A12C+	8.4/11.2	28.66/38.21	23.4/27.0	37/42	40/40	45/45	30/34	—	—	—	—				
	A15C+	10.8/14.4	36.84/49.13	30.1/34.7	46/51	50/50	60/60	38/44	—	—	—	—				
A20C+	14.4/19.2	49.13/65.50	40.1/46.2	58/66	60/60	70/70	51/58	—	—	—	—					
*A21C+	14.4/19.2	49.13/65.50	40.1/46.2	58/66	60/60	70/70	51/58	—	—	—	—					
A048CK	NONE*	—	—	—	25/25	30/35	30/35	—	—	25/25	30/35	30/35				
	A06C+	4.2/5.6	14.33/19.10	11.7/13.5	25/25	30/35	30/35	15/20	—	—	—	—				
	A10C+	7.2/9.6	24.56/32.75	20.0/23.1	33/37	35/35	40/40	25/30	—	—	—	—				
	*A11C+	7.2/9.6	24.56/32.75	20.0/23.1	33/37	35/35	40/40	25/29	—	—	—	—				
	A12C+	8.4/11.2	28.66/38.21	23.4/27.0	37/42	40/40	45/45	30/34	—	—	—	—				
	A15C+	10.8/14.4	36.84/49.13	30.1/34.7	46/51	50/50	60/60	38/44	—	—	—	—				
A20C+	14.4/19.2	49.13/65.50	40.1/46.2	58/66	60/60	70/70	51/58	—	—	—	—					
*A21C+	14.4/19.2	49.13/65.50	40.1/46.2	58/66	60/60	70/70	51/58	—	—	—	—					
A060CK	NONE*	—	—	—	30/30	35/45	35/45	—	—	30/30	35/45	35/45				
	A06C+	4.2/5.6	14.33/19.10	11.7/13.5	30/30	35/45	35/45	15/20	—	—	—	—				
	A10C+	7.2/9.6	24.56/32.75	20.0/23.1	35/39	35/45	40/45	25/30	—	—	—	—				
	*A11C+	7.2/9.6	24.56/32.75	20.0/23.1	35/39	35/45	40/45	25/29	—	—	—	—				
	A12C+	8.4/11.2	28.66/38.21	23.4/27.0	39/44	40/45	45/45	30/34	—	—	—	—				
	A15C+	10.8/14.4	36.84/49.13	30.1/34.7	48/53	50/50	60/60	38/44	—	—	—	—				
A20C+	14.4/19.2	49.13/65.50	40.1/46.2	60/68	60/60	70/70	51/58	—	—	—	—					
*A21C+	14.4/19.2	49.13/65.50	40.1/46.2	60/68	60/60	70/70	51/58	—	—	—	—					

\*= For Canadian use only. Uses "P" fuses for inductive circuit.

+ = Field installed only.



# UNITS WITH HEATER KITS—RLPL- SERIES

208-240 VOLT, THREE PHASE, 60 HZ, AUXILIARY ELECTRIC HEATER KITS CHARACTERISTICS AND APPLICATION												
Separate Power Supply For Both Unit and Heater Kit												
Model No. RLPL-	RXJJ- Heater Kit Nominal kW	Rated Heater kW @ 208/240 V	Heater KBTU/Hr @ 208/240 V	Heater Amp. @ 208/240 V	Unit Min. Ckt. Ampacity @ 208/240 V	Over Current Protective Device Size		Heater Kit Min. Ckt. Ampacity 208/240 V	Heater Kit Max. Fuse Size 208/240 V	Air Cond. Min. Ckt. Ampacity 208/240 V	Air Cond. Over Current Protective Device Size	
						Min./Max. @ 208 V	Min./Max. @ 240 V				Min./Max. @ 208 V	Min./Max. @ 240 V
A036CL	NONE*	—	—	—	18/18	20/25	20/25	—	—	18/18	20/25	20/25
	A060+	4.2/5.6	14.33/19.10	11.7/13.5	19/21	20/25	25/25	15/17	15/20	—	—	—
	A100+	7.2/9.6	24.56/32.75	20.0/23.1	29/33	30/30	35/35	25/29	25/30	—	—	—
	*A110+	7.2/9.6	24.56/32.75	20.0/23.1	29/33	30/30	35/35	25/29	25/30	—	—	—
	A120+	8.4/11.2	28.66/38.21	23.4/27.0	33/38	35/35	40/40	30/34	30/35	—	—	—
	A150+	10.8/14.4	36.84/49.13	30.1/34.7	42/47	45/45	50/50	38/44	40/45	—	—	—
A042CL	NONE*	—	—	—	54/62	60/60	70/70	51/58	60/60	—	—	—
	A060+	4.2/5.6	14.33/19.10	11.7/13.5	22/22	25/30	25/30	—	15/20	22/22	25/30	25/30
	A100+	7.2/9.6	24.56/32.75	20.0/23.1	29/33	30/30	35/35	15/17	15/20	—	—	—
	*A110+	7.2/9.6	24.56/32.75	20.0/23.1	29/33	30/30	35/35	25/29	25/30	—	—	—
	A120+	8.4/11.2	28.66/38.21	23.4/27.0	33/38	35/35	40/40	30/34	30/35	—	—	—
	A150+	10.8/14.4	36.84/49.13	30.1/34.7	42/47	45/45	50/50	38/44	40/45	—	—	—
A048CL	NONE*	—	—	—	54/62	60/60	70/70	51/58	60/60	—	—	—
	A060+	4.2/5.6	14.33/19.10	11.7/13.5	22/22	25/35	25/35	—	15/20	22/22	25/35	25/35
	A100+	7.2/9.6	24.56/32.75	20.0/23.1	29/33	30/35	35/35	15/17	15/20	—	—	—
	*A110+	7.2/9.6	24.56/32.75	20.0/23.1	29/33	30/35	35/35	25/29	25/30	—	—	—
	A120+	8.4/11.2	28.66/38.21	23.4/27.0	33/38	35/35	40/40	30/34	30/35	—	—	—
	A150+	10.8/14.4	36.84/49.13	30.1/34.7	42/47	45/45	50/50	38/44	40/45	—	—	—
A060CL	NONE*	—	—	—	54/62	60/60	70/70	51/58	60/60	—	—	—
	A060+	4.2/5.6	14.33/19.10	11.7/13.5	26/26	30/40	30/40	—	15/20	26/26	30/40	30/40
	A100+	7.2/9.6	24.56/32.75	20.0/23.1	30/34	30/40	35/40	15/17	15/20	—	—	—
	*A110+	7.2/9.6	24.56/32.75	20.0/23.1	30/34	30/40	35/40	25/29	25/30	—	—	—
	A120+	8.4/11.2	28.66/38.21	23.4/27.0	34/38	35/40	40/40	30/34	30/35	—	—	—
	A150+	10.8/14.4	36.84/49.13	30.1/34.7	42/48	45/45	50/50	38/44	40/45	—	—	—
A060CL	NONE*	—	—	—	55/62	60/60	70/70	51/58	60/60	—	—	—
	A060+	4.2/5.6	14.33/19.10	11.7/13.5	55/62	60/60	70/70	51/58	60/60	—	—	—
	A100+	7.2/9.6	24.56/32.75	20.0/23.1	55/62	60/60	70/70	51/58	60/60	—	—	—
	*A110+	7.2/9.6	24.56/32.75	20.0/23.1	55/62	60/60	70/70	51/58	60/60	—	—	—
	A120+	8.4/11.2	28.66/38.21	23.4/27.0	67/77	70/70	80/80	63/73	70/80	—	—	—
	A150+	10.8/14.4	36.84/49.13	30.1/34.7	67/77	70/70	80/80	63/73	70/80	—	—	—

\*= For Canadian use only. Uses "P" fuses for inductive circuit.  
+ = Field installed only.



208-240 VOLT, THREE PHASE, 60 HZ, AUXILIARY ELECTRIC HEATER KITS CHARACTERISTICS AND APPLICATION												
Separate Power Supply For Both Unit and Heater Kit												
Model No. RLPL -	RXJ- Heater Kit Nominal kW	Rated Heater kW @ 208/240 V	Heater KBTU/Hr @ 208/240 V	Heater Amp. @ 208/240 V	Unit Min. Ckt. Ampacity @ 208/240 V	Over Current Protective Device Size		Heater Kit Min. Ckt. Ampacity 208/240 V	Heater Kit Max. Fuse Size 208/240 V	Air Cond. Min. Ckt. Ampacity 208/240 V	Air Cond. Over Current Protective Device Size	
						Min./Max. @ 208 V	Min./Max. @ 240 V				Min./Max. @ 208 V	Min./Max. @ 240 V
A036CM	NONE*	—	—	—	18/18	25/25	25/25	—	—	18/18	25/25	25/25
	A060+	4.2/5.6	14.33/19.10	11.7/13.5	19/22	25/25	25/25	15/17	15/20	—	—	—
	A100+	7.2/9.6	24.56/32.75	20.0/23.1	30/34	30/30	35/35	25/29	25/30	—	—	—
	*A110+	7.2/9.6	24.56/32.75	20.0/23.1	30/34	30/30	35/35	25/29	25/30	—	—	—
	A120+	8.4/11.2	28.66/38.21	23.4/27.0	34/38	35/35	40/40	30/34	30/35	—	—	—
	A150+	10.8/14.4	36.84/49.13	30.1/34.7	42/48	45/45	50/50	38/44	40/45	—	—	—
A042CM	A200+	14.4/19.2	49.13/65.50	40.1/46.2	55/62	60/60	70/70	51/58	60/60	—	—	—
	*A210+	14.4/19.2	49.13/65.50	40.1/46.2	55/62	60/60	70/70	51/58	60/60	—	—	—
	NONE*	—	—	—	22/22	30/35	30/35	—	—	22/22	30/35	30/35
	A060+	4.2/5.6	14.33/19.10	11.7/13.5	22/22	30/35	30/35	15/17	15/20	—	—	—
	A100+	7.2/9.6	24.56/32.75	20.0/23.1	30/34	30/35	35/35	25/29	25/30	—	—	—
	*A110+	7.2/9.6	24.56/32.75	20.0/23.1	30/34	30/35	35/35	25/29	25/30	—	—	—
A048CM	A120+	8.4/11.2	28.66/38.21	23.4/27.0	34/38	35/35	40/40	30/34	30/35	—	—	—
	A150+	10.8/14.4	36.84/49.13	30.1/34.7	42/48	45/45	50/50	38/44	40/45	—	—	—
	A200+	14.4/19.2	49.13/65.50	40.1/46.2	55/62	60/60	70/70	51/58	60/60	—	—	—
	*A210+	14.4/19.2	49.13/65.50	40.1/46.2	55/62	60/60	70/70	51/58	60/60	—	—	—
	NONE*	—	—	—	23/23	30/35	30/35	—	—	23/23	30/35	30/35
	A060+	4.2/5.6	14.33/19.10	11.7/13.5	23/23	30/35	30/35	15/17	15/20	—	—	—
A060CM	A100+	7.2/9.6	24.56/32.75	20.0/23.1	30/34	30/35	35/35	25/29	25/30	—	—	—
	*A110+	7.2/9.6	24.56/32.75	20.0/23.1	30/34	30/35	35/35	25/29	25/30	—	—	—
	A120+	8.4/11.2	28.66/38.21	23.4/27.0	34/38	35/35	40/40	30/34	30/35	—	—	—
	A150+	10.8/14.4	36.84/49.13	30.1/34.7	42/48	45/45	50/50	38/44	40/45	—	—	—
	A200+	14.4/19.2	49.13/65.50	40.1/46.2	55/62	60/60	70/70	51/58	60/60	—	—	—
	*A210+	14.4/19.2	49.13/65.50	40.1/46.2	55/62	60/60	70/70	51/58	60/60	—	—	—
A060CM	NONE*	—	—	—	26/26	30/40	30/40	—	—	26/26	30/40	30/40
	A060+	4.2/5.6	14.33/19.10	11.7/13.5	26/26	30/40	30/40	15/17	15/20	—	—	—
	A100+	7.2/9.6	24.56/32.75	20.0/23.1	30/34	30/40	35/40	25/29	25/30	—	—	—
	*A110+	7.2/9.6	24.56/32.75	20.0/23.1	30/34	30/40	35/40	25/29	25/30	—	—	—
	A120+	8.4/11.2	28.66/38.21	23.4/27.0	34/39	35/40	40/40	30/34	30/35	—	—	—
	A150+	10.8/14.4	36.84/49.13	30.1/34.7	43/49	45/45	50/50	38/44	40/45	—	—	—
A060CM	A200+	14.4/19.2	49.13/65.50	40.1/46.2	55/63	60/60	70/70	51/58	60/60	—	—	—
	*A210+	14.4/19.2	49.13/65.50	40.1/46.2	55/63	60/60	70/70	51/58	60/60	—	—	—
	A240+	18.0/24.0	61.41/81.88	50.1/57.8	68/77	70/70	80/80	63/73	70/80	—	—	—

\*= For Canadian use only. Uses "P" fuses for inductive circuit.  
+ = Field installed only.



# UNITS WITH HEATER KITS—RLPL- SERIES

460 VOLT, THREE PHASE, 60 HZ, AUXILIARY ELECTRIC HEATER KITS CHARACTERISTICS AND APPLICATION												
Model No. RLPL-	Single Power Supply For Both Unit and Heater Kit						Separate Power Supply For Both Unit and Heater Kit					
	RXJJ- Heater Kit Nominal kW	Rated Heater kW @ 460 V	Heater KBTU/Hr @ 460 V	Heater Amp. @ 460 V	Unit Min. Ckt. Ampacity @ 460 V	Over Current Protective Device Size @ 460 V		Heater Kit Min. Ckt. Ampacity 460 V	Heater Kit Max. Fuse Size 460 V	Air Cond. Min. Ckt. Ampacity 460 V	Air Cond. Protective Device Size @ 460 V	
						Min./Max.	Min./Max.				Min./Max.	Min./Max.
A036DK	NONE*	—	—	—	11	15/15	—	—	—	11	15/15	—
	A06D+	5.6	19.10	6.7	11	15/15	—	—	—	—	—	—
	A10D+	9.6	32.75	11.6	18	20/20	—	—	—	—	—	—
	*A11D+	9.6	32.75	11.6	18	20/20	—	—	—	—	—	—
	A12D+	11.2	38.21	13.5	20	20/20	—	—	—	—	—	—
	A15D+	14.4	49.13	17.4	25	25/25	—	—	—	—	—	—
	A20D+	19.2	65.50	23.3	32	35/35	—	—	—	—	—	—
A042DK	*A21D+	19.2	65.50	23.3	32	35/35	—	—	—	—	—	—
	NONE*	—	—	—	12	15/15	—	—	—	12	15/15	—
	A06D+	5.6	19.10	6.7	13	15/15	—	—	—	—	—	—
	A10D+	9.6	32.75	11.6	19	20/20	—	—	—	—	—	—
	*A11D+	9.6	32.75	11.6	19	20/20	—	—	—	—	—	—
	A12D+	11.2	38.21	13.5	21	25/25	—	—	—	—	—	—
	A15D+	14.4	49.13	17.4	26	30/30	—	—	—	—	—	—
A048DK	A20D+	19.2	65.50	23.3	34	35/35	—	—	—	—	—	—
	*A21D+	19.2	65.50	23.3	34	35/35	—	—	—	—	—	—
	NONE*	—	—	—	12	15/15	—	—	—	12	15/15	—
	A06D+	5.6	19.10	6.7	13	15/15	—	—	—	—	—	—
	A10D+	9.6	32.75	11.6	19	20/20	—	—	—	—	—	—
	*A11D+	9.6	32.75	11.6	19	20/20	—	—	—	—	—	—
	A12D+	11.2	38.21	13.5	21	25/25	—	—	—	—	—	—
A060DK	A15D+	14.4	49.13	17.4	26	30/30	—	—	—	—	—	—
	A20D+	19.2	65.50	23.3	34	35/35	—	—	—	—	—	—
	*A21D+	19.2	65.50	23.3	34	35/35	—	—	—	—	—	—
	NONE*	—	—	—	15	20/20	—	—	—	15	20/20	—
	A06D+	5.6	19.10	6.7	15	20/20	—	—	—	—	—	—
	A10D+	9.6	32.75	11.6	20	20/20	—	—	—	—	—	—
	*A11D+	9.6	32.75	11.6	20	20/20	—	—	—	—	—	—
A060DK	A12D+	11.2	38.21	13.5	22	25/25	—	—	—	—	—	—
	A15D+	14.4	49.13	17.3	27	30/30	—	—	—	—	—	—
	A20D+	19.2	65.50	17.4	35	35/35	—	—	—	—	—	—
	*A21D+	19.2	65.50	23.3	35	35/35	—	—	—	—	—	—
	A24D+	24.0	81.88	23.3	42	45/45	—	—	—	—	—	—

\*= For Canadian use only. Uses "P" fuses for inductive circuit.  
+ = Field installed only.



460 VOLT, THREE PHASE, 60 HZ, AUXILIARY ELECTRIC HEATER KITS CHARACTERISTICS AND APPLICATION												
Model No. RLPL-	RXJ- Heater Kit Nominal kW	Rated Heater kW @ 460 V	Heater KBTU/Hr @ 460 V	Heater Amp. @ 460 V	Single Power Supply For Both Unit and Heater Kit				Separate Power Supply For Both Unit and Heater Kit			
					Unit Min. Ckt. Ampacity @ 460 V	Over Current Protective Device Size @ 460 V		Heater Kit Min. Ckt. Ampacity @ 460 V	Heater Kit Max. Fuse Size @ 460 V	Air Cond. Min. Ckt. Ampacity @ 460 V	Air Cond. Over Current Protective Device Size @ 460 V	
						Min./Max.	Min./Max.				Min./Max.	Min./Max.
A036DL	NONE*	—	—	—	10	15/15	—	—	—	10	15/15	—
	A06D+	5.6	19.10	6.7	11	15/15	—	—	9	15	—	—
	A10D+	9.6	32.75	11.6	17	20/20	—	—	15	15	—	—
	*A11D+	9.6	32.75	11.6	17	20/20	—	—	15	15	—	—
	A12D+	11.2	38.21	13.5	19	20/20	—	—	17	20	—	—
	A15D+	14.4	49.13	17.3	24	25/25	—	—	22	25	—	—
A042DL	A20D+	19.2	65.50	23.1	31	35/35	—	—	29	30	—	—
	*A21D+	19.2	65.50	23.1	31	35/35	—	—	29	30	—	—
	NONE*	—	—	—	10	15/15	—	—	—	—	10	15/15
	A06D+	5.6	19.10	6.7	11	15/15	—	—	9	15	—	—
	A10D+	9.6	32.75	11.6	17	20/20	—	—	15	15	—	—
	*A11D+	9.6	32.75	11.6	17	20/20	—	—	15	15	—	—
A048DL	A12D+	11.2	38.21	13.5	19	20/20	—	—	17	20	—	—
	A15D+	14.4	49.13	17.3	24	25/25	—	—	22	25	—	—
	A20D+	19.2	65.50	23.1	31	35/35	—	—	29	30	—	—
	*A21D+	19.2	65.50	23.1	31	35/35	—	—	29	30	—	—
	NONE*	—	—	—	11	15/15	—	—	—	—	11	15/15
	A06D+	5.6	19.10	6.7	11	15/15	—	—	9	15	—	—
A060DL	A10D+	9.6	32.75	11.6	17	20/20	—	—	15	15	—	—
	*A11D+	9.6	32.75	11.6	17	20/20	—	—	15	15	—	—
	A12D+	11.2	38.21	13.5	19	20/20	—	—	17	20	—	—
	A15D+	14.4	49.13	17.3	24	25/25	—	—	22	25	—	—
	A20D+	19.2	65.50	23.1	31	35/35	—	—	29	30	—	—
	*A21D+	19.2	65.50	23.1	31	35/35	—	—	29	30	—	—
A066DL	NONE*	—	—	—	13	15/20	—	—	—	—	13	15/20
	A06D+	5.6	19.10	6.7	13	15/20	—	—	9	15	—	—
	A10D+	9.6	32.75	11.6	17	20/20	—	—	15	15	—	—
	*A11D+	9.6	32.75	11.6	17	20/20	—	—	15	15	—	—
	A12D+	11.2	38.21	13.5	19	20/20	—	—	17	20	—	—
	A15D+	14.4	49.13	17.3	24	25/25	—	—	22	25	—	—
A072DL	A20D+	19.2	65.50	23.1	31	35/35	—	—	29	30	—	—
	*A21D+	19.2	65.50	23.1	31	35/35	—	—	29	30	—	—
	NONE*	—	—	—	13	15/20	—	—	—	—	13	15/20
	A06D+	5.6	19.10	6.7	13	15/20	—	—	9	15	—	—
	A10D+	9.6	32.75	11.6	17	20/20	—	—	15	15	—	—
	*A11D+	9.6	32.75	11.6	17	20/20	—	—	15	15	—	—
A078DL	A12D+	11.2	38.21	13.5	19	20/20	—	—	17	20	—	—
	A15D+	14.4	49.13	17.3	24	25/25	—	—	22	25	—	—
	A20D+	19.2	65.50	23.1	31	35/35	—	—	29	30	—	—
	*A21D+	19.2	65.50	23.1	31	35/35	—	—	29	30	—	—
	NONE*	—	—	—	13	15/20	—	—	—	—	13	15/20
	A06D+	5.6	19.10	6.7	13	15/20	—	—	9	15	—	—
A084DL	A10D+	9.6	32.75	11.6	17	20/20	—	—	15	15	—	—
	*A11D+	9.6	32.75	11.6	17	20/20	—	—	15	15	—	—
	A12D+	11.2	38.21	13.5	19	20/20	—	—	17	20	—	—
	A15D+	14.4	49.13	17.3	24	25/25	—	—	22	25	—	—
	A20D+	19.2	65.50	23.1	31	35/35	—	—	29	30	—	—
	*A21D+	19.2	65.50	23.1	31	35/35	—	—	29	30	—	—
A090DL	A24D+	24.0	81.88	28.9	39	40/40	—	—	37	40	—	—

\*= For Canadian use only. Uses "P" fuses for inductive circuit.  
 += Field installed only.



# UNITS WITH HEATER KITS—RLPL- SERIES

## 460 VOLT, THREE PHASE, 60 HZ, AUXILIARY ELECTRIC HEATER KITS CHARACTERISTICS AND APPLICATION

		Single Power Supply For Both Unit and Heater Kit						Separate Power Supply For Both Unit and Heater Kit					
Model No. RLPL-	RXJJ- Heater Kit Nominal kW	Rated Heater kW @ 460 V	Heater KBTU/Hr @ 460 V	Heater Amp. @ 460 V	Unit Min. Ckt. Ampacity @ 460 V	Over Current Protective Device Size @ 460 V		Heater Kit Min. Ckt. Ampacity 460 V	Heater Kit Max. Fuse Size 460 V	Air Cond. Ampacity 460 V	Air Cond. Over Current Protective Device Size @ 460 V		
						Min./Max.	Min./Max.				Min./Max.	Min./Max.	
A036DM	NONE*	—	—	—	10	15/15	—	—	—	10	15/15	—	
	A06D+	5.6	19.10	6.7	11	15/15	—	—	—	—	—	—	
	A10D+	9.6	32.75	11.6	17	20/20	—	—	—	—	—	—	
	*A11D+	9.6	32.75	11.6	17	20/20	—	—	—	—	—	—	
	A12D+	11.2	38.21	13.5	19	20/20	—	—	—	—	—	—	
	A15D+	14.4	49.13	17.3	24	25/25	—	—	—	—	—	—	
A042DM	A20D+	19.2	65.50	23.1	31	35/35	—	—	—	—	—	—	
	*A21D+	19.2	65.50	23.1	31	35/35	—	—	—	—	—	—	
	NONE*	—	—	—	11	15/15	—	—	—	11	15/15	—	
	A06D+	5.6	19.10	6.7	11	15/15	—	—	—	—	—	—	
	A10D+	9.6	32.75	11.6	17	20/20	—	—	—	—	—	—	
	*A11D+	9.6	32.75	11.6	17	20/20	—	—	—	—	—	—	
A048DM	A12D+	11.2	38.21	13.5	19	20/20	—	—	—	—	—	—	
	A15D+	14.4	49.13	17.3	24	25/25	—	—	—	—	—	—	
	A20D+	19.2	65.50	23.1	31	35/35	—	—	—	—	—	—	
	*A21D+	19.2	65.50	23.1	31	35/35	—	—	—	—	—	—	
	NONE*	—	—	—	11	15/15	—	—	—	11	15/15	—	
	A06D+	5.6	19.10	6.7	11	15/15	—	—	—	—	—	—	
A060DM	A10D+	9.6	32.75	11.6	17	20/20	—	—	—	—	—	—	
	*A11D+	9.6	32.75	11.6	17	20/20	—	—	—	—	—	—	
	A12D+	11.2	38.21	13.5	20	20/20	—	—	—	—	—	—	
	A15D+	14.4	49.13	17.3	24	25/25	—	—	—	—	—	—	
	A20D+	19.2	65.50	23.1	32	35/35	—	—	—	—	—	—	
	*A21D+	19.2	65.50	23.1	32	35/35	—	—	—	—	—	—	
	A24D+	24.0	81.88	28.9	39	40/40	—	—	—	—	—	—	
	NONE*	—	—	—	13	15/20	—	—	—	13	15/20	—	
	A06D+	5.6	19.10	6.7	13	15/20	—	—	—	—	—	—	
	A10D+	9.6	32.75	11.6	17	20/20	—	—	—	—	—	—	
	*A11D+	9.6	32.75	11.6	17	20/20	—	—	—	—	—	—	
	A12D+	11.2	38.21	13.5	20	20/20	—	—	—	—	—	—	

\*= For Canadian use only. Uses "P" fuses for inductive circuit.

+ = Field installed only.



208-240 VOLT, THREE PHASE, 60 HZ, AUXILIARY ELECTRIC HEATER KITS CHARACTERISTICS AND APPLICATION												
Model No. RLPL-	Single Power Supply For Both Unit and Heater Kit						Separate Power Supply For Both Unit and Heater Kit					
	RXJJ- Heater Kit Nominal kW	Rated Heater kW @ 208/240 V	Heater KBTU/Hr @ 208/240 V	Heater Amp. @ 208/240 V	Unit Min. Ckt. Ampacity @ 208/240 V	Over Current Protective Device Size		Heater Kit Min. Ckt. Ampacity 208/240 V	Heater Kit Max. Fuse Size 208/240 V	Air Cond. Min. Ckt. Ampacity 208/240 V	Air Cond. Over Current Protective Device Size	
						Min./Max. @ 208 V	Min./Max. @ 240 V				Min./Max. @ 208 V	Min./Max. @ 240 V
A036JK	NONE*	—	—	—	27/27	35/40	35/40	—	—	27/27	35/40	35/40
	A06J+	4.2/5.6	14.33/19.10	20.2/23.3	31/35	35/40	35/40	26/30	30/30	—	—	—
	A10J+	7.2/9.6	24.56/32.75	34.7/40.0	49/56	50/50	60/60	44/50	45/50	—	—	—
	*A11J+	7.2/9.6	24.56/32.75	34.7/40.0	49/56	50/50	60/60	44/50	45/50	—	—	—
	A12J+	8.4/11.2	28.66/38.21	40.4/46.7	56/64	60/60	70/70	51/59	60/60	—	—	—
	A15J+	10.8/14.4	36.84/49.13	52.0/60.0	71/81	80/80	90/90	65/75	70/80	—	—	—
A042JK	A20J+	14.4/19.2	49.13/65.50	69.3/80.0	92/106	100/100	110/110	87/100	90/100	—	—	—
	*A21J+	14.4/19.2	49.13/65.50	69.3/80.0	92/106	100/100	110/110	87/100	90/100	—	—	—
	NONE*	—	—	—	30/30	35/45	35/45	—	—	30/30	35/45	35/45
	A06J+	4.2/5.6	14.33/19.10	20.2/23.3	33/37	35/45	40/45	26/30	30/30	—	—	—
	A10J	7.2/9.6	24.56/32.75	34.7/40.0	51/58	60/60	60/60	44/50	45/50	—	—	—
	*A11J+	7.2/9.6	24.56/32.75	34.7/40.0	51/58	60/60	60/60	44/50	45/50	—	—	—
A048JK	A12J+	8.4/11.2	28.66/38.21	40.4/46.7	58/66	60/60	70/70	51/59	60/60	—	—	—
	A15J	10.8/14.4	36.84/49.13	52.0/60.0	73/83	80/80	90/90	65/75	70/80	—	—	—
	A20J	14.4/19.2	49.13/65.50	69.3/80.0	95/108	100/100	110/110	87/100	90/100	—	—	—
	*A21J+	14.4/19.2	49.13/65.50	69.3/80.0	95/108	100/100	110/110	87/100	90/100	—	—	—
	NONE*	—	—	—	35/35	45/50	45/50	—	—	35/35	45/50	45/50
	A06J+	4.2/5.6	14.33/19.10	20.2/23.3	35/37	45/50	45/50	26/30	30/30	—	—	—
A060JK	A10J+	7.2/9.6	24.56/32.75	34.7/40.0	51/58	60/60	60/60	44/50	45/50	—	—	—
	*A11J+	7.2/9.6	24.56/32.75	34.7/40.0	51/58	60/60	60/60	44/50	45/50	—	—	—
	A12J+	8.4/11.2	28.66/38.21	40.4/46.7	58/66	60/60	70/70	51/59	60/60	—	—	—
	A15J	10.8/14.4	36.84/49.13	52.0/60.0	73/83	80/80	90/90	65/75	70/80	—	—	—
	A20J	14.4/19.2	49.13/65.50	69.3/80.0	95/108	100/100	110/110	87/100	90/100	—	—	—
	*A21J+	14.4/19.2	49.13/65.50	69.3/80.0	95/108	100/100	110/110	87/100	90/100	—	—	—
A060JK	NONE*	—	—	—	43/43	50/60	50/60	—	—	43/43	50/60	50/60
	A06J+	4.2/5.6	14.33/19.10	20.2/23.3	43/43	50/60	50/60	26/30	30/30	—	—	—
	A10J+	7.2/9.6	24.56/32.75	34.7/40.0	53/60	60/60	60/60	44/50	45/50	—	—	—
	*A11J+	7.2/9.6	24.56/32.75	34.7/40.0	53/60	60/60	60/60	44/50	45/50	—	—	—
	A12J+	8.4/11.2	28.66/38.21	40.4/46.7	60/68	60/60	70/70	51/59	60/60	—	—	—
	A15J	10.8/14.4	36.84/49.13	52.0/60.0	75/85	80/80	90/90	65/75	70/80	—	—	—
A060JK	*A21J+	14.4/19.2	49.13/65.50	69.3/80.0	97/110	100/100	110/110	87/100	90/100	—	—	—
	*A21J+	14.4/19.2	49.13/65.50	69.3/80.0	97/110	100/100	110/110	87/100	90/100	—	—	—

\*= For Canadian use only. Uses "P" fuses for inductive circuit.  
+ = Field installed only.



# UNIT DIMENSIONS—RLNL/RLPL- SERIES

## UNIT DIMENSIONS PACKAGE AIR CONDITIONERS

## 3 TO 5 TON [10.6 TO 17.6 kW] MODELS

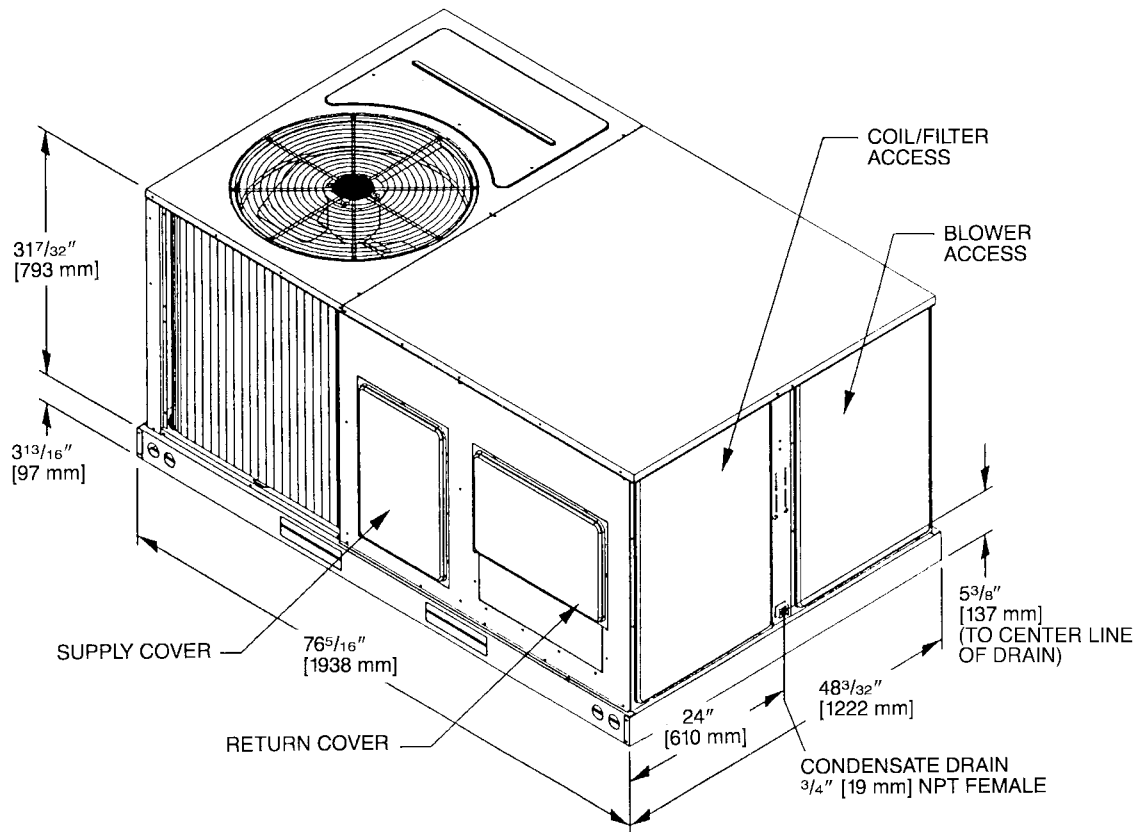

### SUPPLY AND RETURN DIMENSIONS

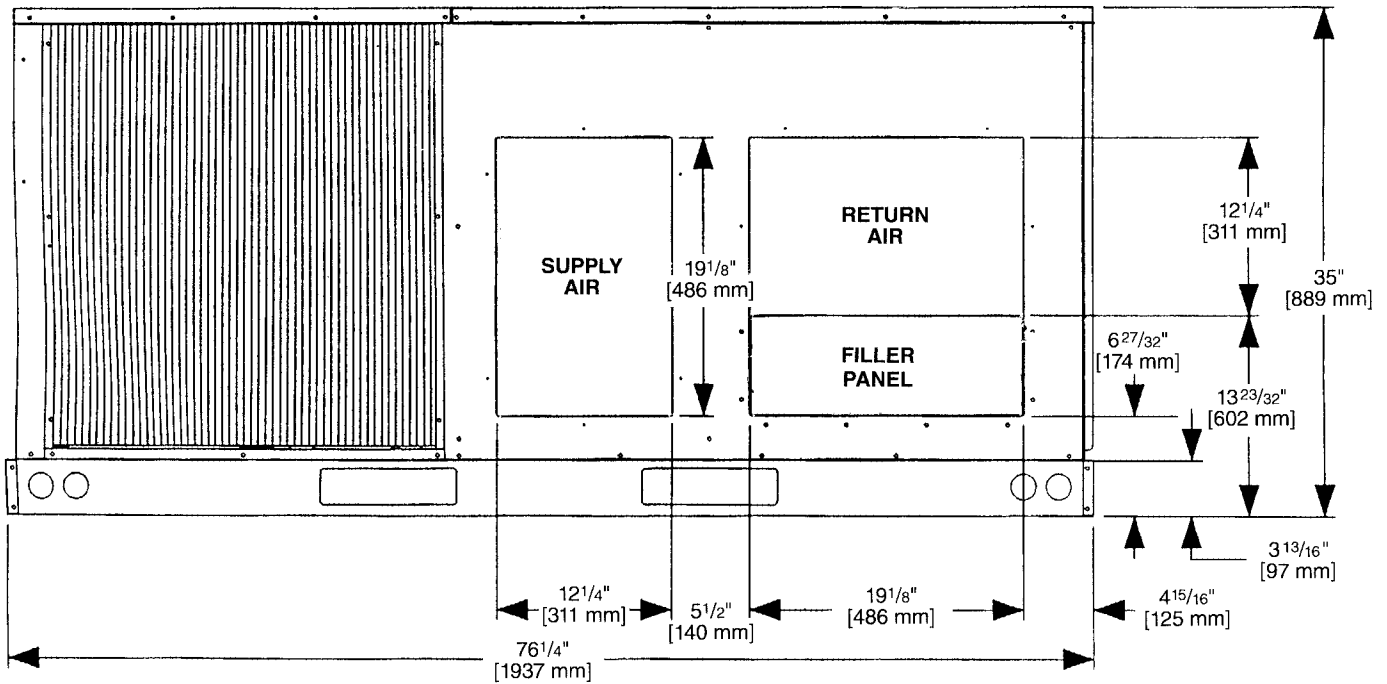

[ ] Designates Metric Conversions

## UNIT DIMENSIONS PACKAGE AIR CONDITIONERS

## 3 TO 5 TON [10.6 TO 17.6 kW] MODELS

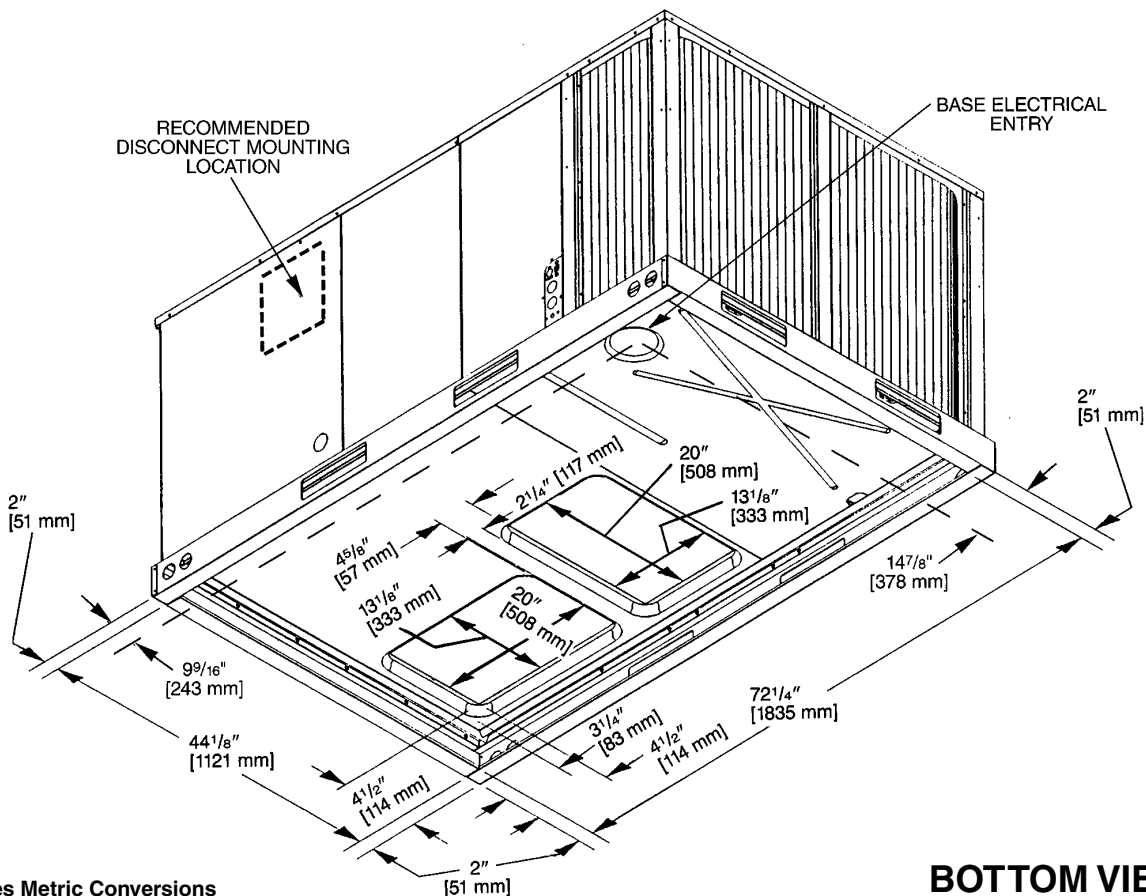
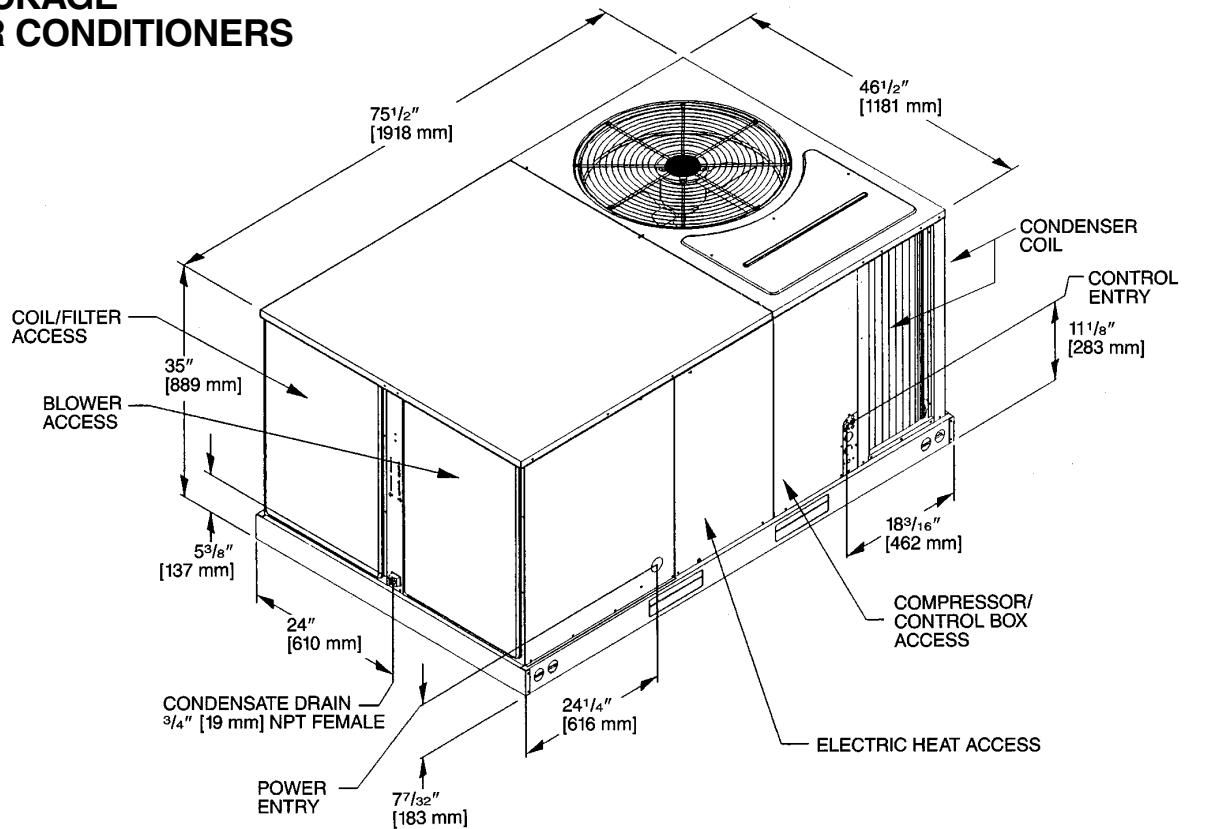

[ ] Designates Metric Conversions

**BOTTOM VIEW**



# UNIT DIMENSIONS—RLNL/RLPL- SERIES

## WEIGHTS

Accessory	3-5 Ton [10.6-17.6 kW]	
	Shipping	Operating
	lbs [kg]	lbs [kg]
Economizer with Single Enthalpy	70 [32]	60 [27]
Power Exhaust	70 [32]	67 [30]
Fresh Air Damper (Manual)	11 [5]	9 [4]
Fresh Air Damper (Motorized)	13 [6]	11 [5]
Roof Curb 14"	92 [42]	88 [40]
Roof Curb 24"	108 [49]	104 [47]
Concentric Diffuser 18" Flush	37 [17]	26 [12]
Concentric Diffuser 20" Flush	54 [24]	42 [19]
Side Discharge Concentric Diffuser RXRN-FA60	35 [16]	20 [9]
Side Discharge Concentric Diffuser RXRN-FA65	55 [25]	40 [18]

## CLEARANCES

### (3 to 5 Ton [10.6 to 17.6 kW] Models)

The following minimum clearances are recommended for proper unit performance and serviceability.

Recommended Clearance in. [mm]	Location
48 [1219]	A - Front
18 [457]	B - Condenser Coil
*12 [305]	C - Duct Side
36 [914]	D - Evaporator End
60 [1524]	E - Above
*57" [1448 mm] With Economizer	

**NOTE:** Supply duct may be installed with "0" inch clearance to combustible materials, provided 1" [25.4 mm] minimum. Fiberglass insulation is applied either inside or on the outside of the duct.

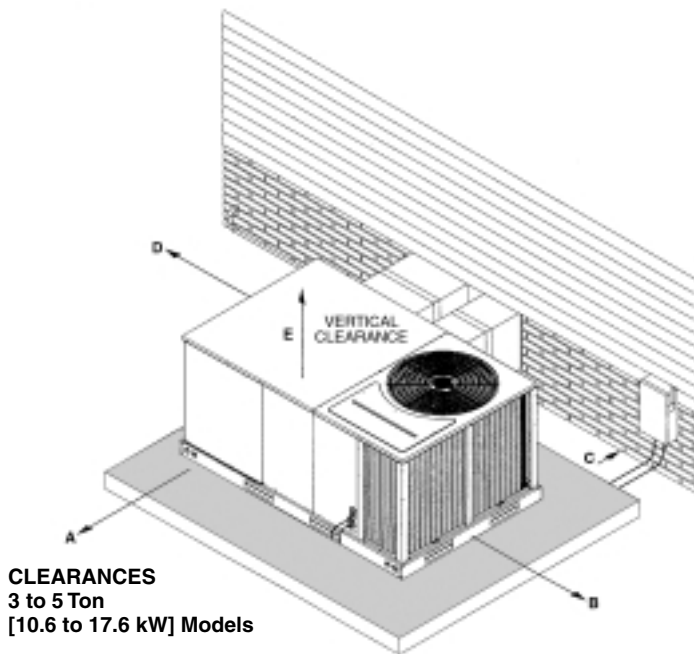

## CENTER OF GRAVITY (C.G.)

Capacity Tons [kW]	A in. [mm]	B in. [mm]
3-5 [10.6-17.6]	38 <sup>1</sup> / <sub>4</sub> [972]	25 <sup>3</sup> / <sub>4</sub> [654]

Capacity Tons [kW]	Corner Weights by Percentage			
	A	B	C	D
3-5 [10.6-17.6]	22%	27%	23%	28%

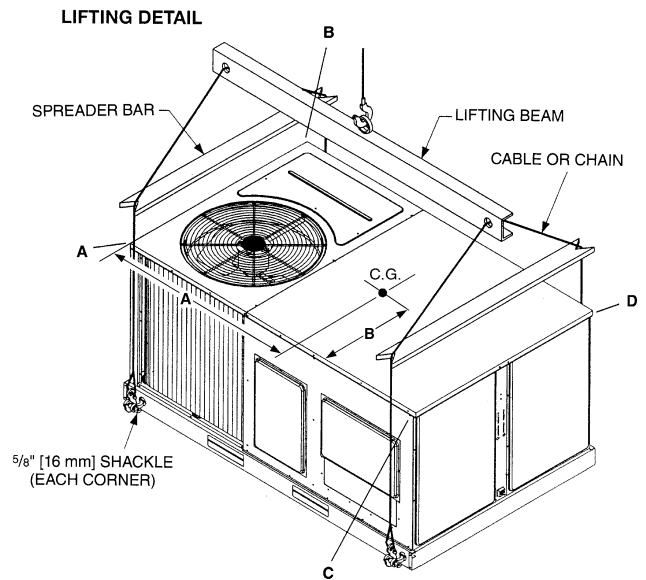

[ ] Designates Metric Conversions

## ACCESSORY EQUIPMENT

Accessory Description	Model Application 3 to 5 Ton [10.6 to 17.6 kW]	Accessory Model No. 3 to 5 Ton [10.6 to 17.6 kW]	Factory Installed 3 to 5 Ton [10.6 to 17.6 kW]
Thermostats	RLNL-/RLPL-	See Thermostat Specification Sheet (T11-001)	No
Electric Heater Kits	RLNL-/RLPL-	RXJJ-A06 (J,C,D) RXJJ-A10 (J,C,D) RXJJ-A11 (J,C,D) RXJJ-A12 (J,C,D) RXJJ-A15 (J,C,D) RXJJ-A20 (J,C,D) RXJJ-A21 (J,C,D) RXJJ-A24 (J,C,D)	See Heater Kit Electric Table
Roofcurb 14"	RLNL-/RLPL-	RXKG-CAD14	No
Roofcurb 24"	RLNL-/RLPL-	RXKG-CAD24	No
Roofcurb Adapters	RLNL-/RLPL-	RRRX-BBCDB21 RRRX-BBCDB22 RRRX-BBCDB23	No
Economizer with Single Enthalpy ①	RLNL-/RLPL-	RXRD-MECM3	Yes
Dual Enthalpy Kit	RLNL-/RLPL-	RRRX-AV02	No
CO <sub>2</sub> Sensor	RLNL-/RLPL-	RRRX-AR02	No
Power Exhaust	RLNL-/RLPL-	RRRX-BGF04 (C, D & Y)	No
Fresh Air Damper Manual	RLNL-/RLPL-	RXRF-FBA1	No
Fresh Air Damper Motorized	RLNL-/RLPL-	RXRF-FBB1	No
Rectangular to Round 18" Duct Adapters for Concentric Diffuser	RLNL-/RLPL-	RXMC-CB03	No
Rectangular to Round 20" Duct Adapters for Concentric Diffuser	RLNL-/RLPL-	RXMC-CB04	No
Concentric Diffuser 18" Step	RLNL-/RLPL-	RXRN-FA60, RXRN-FA65	No
Concentric Diffuser 18" Flush	RLNL-/RLPL-	RXRN-FA70, RXRN-FA75	No
Rectangular to Round 16" Side	RLNL-/RLPL-	RXMC-BB01	No
Louver Kit (3 Sides)	All RLNL-/RLPL- Models	RRRX-AAD01B	Yes
Time Delay	RLNL-/RLPL-	RXMD-B01	Yes
Low Ambient Control to 0°F [-18°C]	RLNL-/RLPL-	RXRZ-B01	Yes

\*Voltage  
 J = 208-230 VAC-1PH-60HZ    D = 460 VAC-3PH-60HZ  
 C = 208-230 VAC-3PH-60HZ

**NOTES:** ① Economizer is designed for downflow or horizontal applications.

[ ] Designates Metric Conversions

**THERMOSTATS**

**100-Series \***  
Non-Programmable

**200-Series \***  
Programmable

**300-Series \***  
Deluxe  
Programmable

**400-Series \***  
Special Applications/  
Programmable

**500-Series \***  
Communicating/  
Programmable

Brand	Unique Model Number Prefix	Descriptor (3 Characters)	Series (3 Characters)	System (2 Characters)	Type (2 Characters)
RHC	-	TST	101	GE	MS
RHC=Rheem		TST=Thermostat	100=Non-Programmable 200=Programmable 300=Deluxe Programmable 400=Special Applications/ Programmable 500=Communicating/ Programmable	GE=Gas/Oil/Electric HP=Heat Pump MD=Modulating Furnace DF=Dual Fuel UN=Universal AC/HP/GE CM=Communicating	SS=Single-Stage MS=Multi-Stage

\* Photos are representative. Actual models may vary.

For detailed thermostat match-up information, see specification sheet form number T11-001.

## ROOFCURBS (Full Perimeter)

- Rheem's new roofcurb design can be utilized on 3 through 5 ton [10.6-17.6 kW] models.
- Two available heights (14" [356 mm] and 24" [610 mm]) for ALL models.
- Quick assembly corners for simple and fast assembly.
- Opening provided in bottom pan to match the "Thru the Curb" electrical connection opening provided on the unit base pan.
- 2" [51 mm] x 4" [102 mm] Nailer provided.
- Insulating panels provided.
- Sealing gasket (28" [711 mm]) provided with Roofcurb.
- Packaged for easy field assembly.

Roofcurb Model	Height of Curb
RXKG-CAD14	14" [356 mm]
RXKG-CAD24	24" [610 mm]

## TYPICAL INSTALLATION

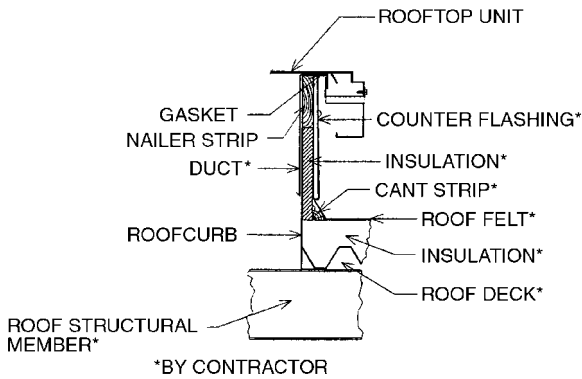
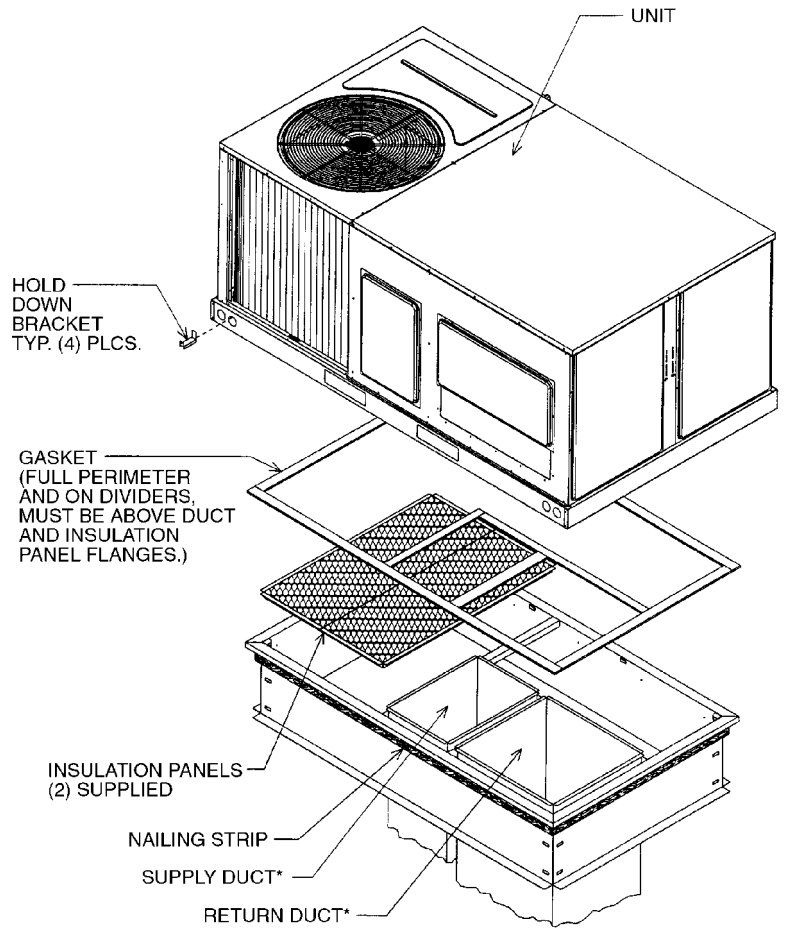

## ROOFCURB FOR RLNL 3-5 TON [10.6-17.6 kW] MODELS RLPL 3-5 TON [10.6-17.6 kW] MODELS

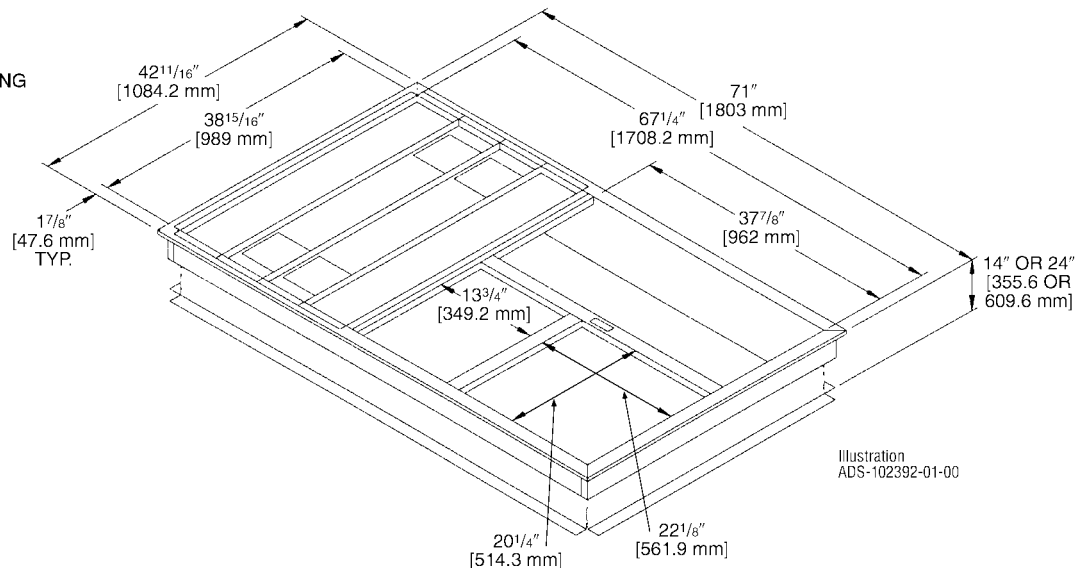
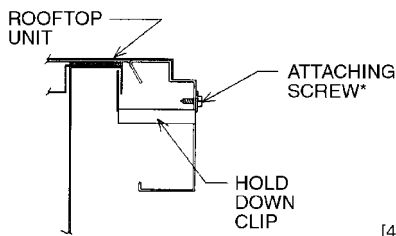

[ ] Designates Metric Conversions

Illustration  
ADS-102392-01-00

## ROOFCURB ADAPTERS

### Old Models

#### MEDIUM CABINET (3 TON [11 kW])

(-)SNC, (-)SND, (-)SNE  
 (-)RGE, (-)RGF, (-)RGG  
 (-)PNC, (-)PND

#### LARGE CABINET (3-3.5 TON [11-12 kW])

(-)RGE, (-)RGF, (-)RGG,  
 (-)RGH (3 TON [11 kW])

#### EXTRA LARGE CABINET (3.5-5 TON [12-18 kW])

(-)SNC, (-)SND, (-)SNE  
 (-)RGE, (-)RGF,  
 (-)RGG (4-5 TON [14-18 kW])  
 (-)PNC, (-)PND, (-)RGH  
 (3.5, 4 TON [12-14 kW])

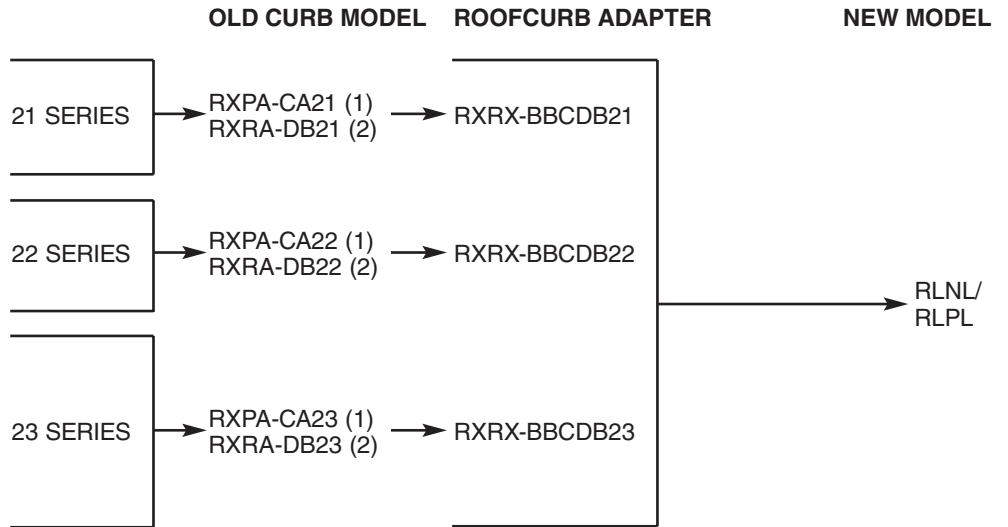

## Field Installed Resistance Heater Kits

Electric Heater Kits are designed for field installation using either single-point power wiring or dual circuit wiring. Low voltage plugs are provided to allow for quick connection to the unit. Removing a block-off panel on the unit allows the heater elements to be inserted into the supply air down stream from the indoor coil and supply air blower.

[ ] Designates Metric Conversions

### Model Number Identifier:

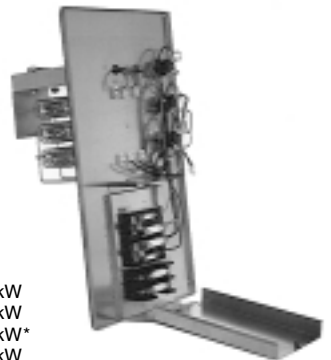
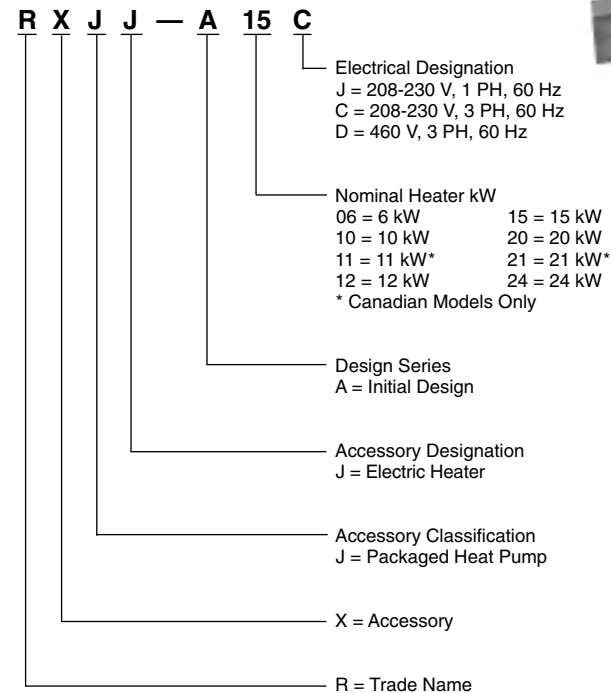

## ECONOMIZERS

RXRD-MECM3—RLNL 3-5 Ton [10.6-17.6 kW] Models  
 RLPL 3-5 Ton [10.6-17.6 kW] Models

RXRX-AV02—Dual Enthalpy Kit  
 3-5 Ton [10.6-17.6 kW] Models

RXRX-AR02—3-5 Ton [10.6-17.6 kW] Models    **Optional CO<sub>2</sub> Sensor**

- Features **Honeywell** Controls
- Available factory installed or field accessory
- Gear Driven Direct Drive Actuator
- Fully Modulating (0-100%)
- Low Leakage Dampers
- Horizontal or Downflow Applications
- Slip-In Design for Easy Installations
- Plug-In Polarized 9-pin Electrical Connections
- Pre-configured—No Field Adjustments Necessary
- Standard Barometric Relief Damper Provided
- Single Enthalpy with Dual Enthalpy Upgrade Kit
- CO<sub>2</sub> Input Sensor Available (Field Installed)
- Economizer slips in complete for Downflow or Horizontal Duct application
- Field Assembled Hood Ships with Economizer
- Optional Remote Minimum Position (Honeywell #S963B1128) is Available from ProStock
- Field Installed Power Exhaust Available

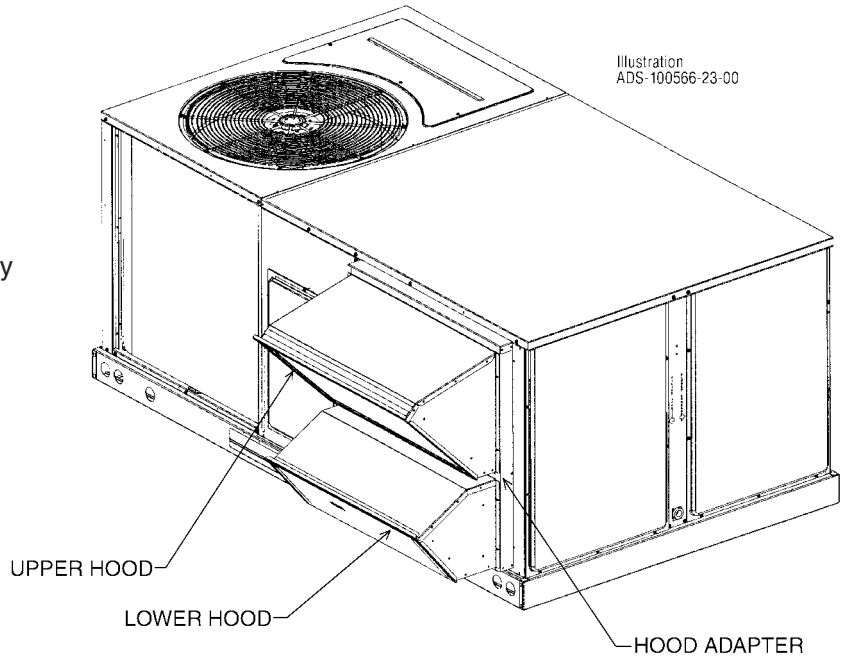

### 3-5 Ton [10.6-17.6 kW] Models

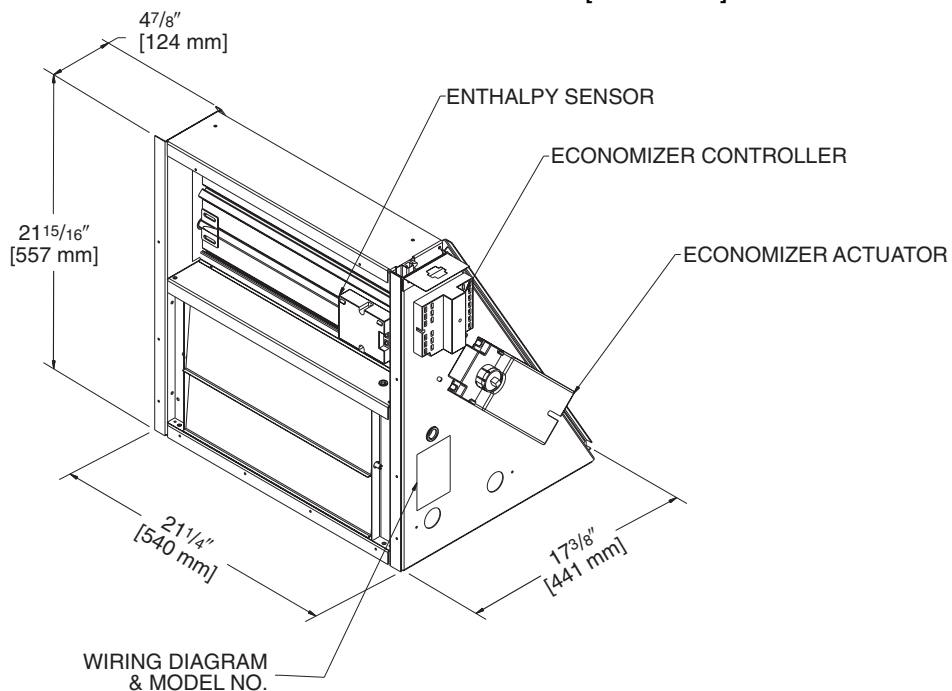

[ ] Designates Metric Conversions

## INTEGRAL POWER EXHAUST FOR ECONOMIZER (FIELD INSTALLED ONLY)

**RXXRX-BGF04C** – RLNL 3-5 Ton [10.6-17.6 kW] Models & RLPL 3-5 Ton [10.6-17.6 kW] Models  
208-230V, 1 PH and 3 PH, 60 Hz

**RXXRX-BGF04D** – RLNL 3-5 Ton [10.6-17.6 kW] Models & RLPL 3-5 Ton [10.6-17.6 kW] Models  
460V, 3 PH, 60 Hz

**RXXRX-BGF04Y** – RLNL 3-5 Ton [10.6-17.6 kW] Models & RLPL 3-5 Ton [10.6-17.6 kW] Models  
575V, 3 PH, 60 Hz

- For **Honeywell** Economizer
- Downflow or horizontal applications
- Requires separate 208-230 Volt – 1 PH power supply with disconnect or requires separate 460V – 3 PH power supply with disconnect
- Adjustable switch on economizer, factory preset to energize power exhaust at 95% outside air position
- Polarized plug connects power exhaust relay to economizer

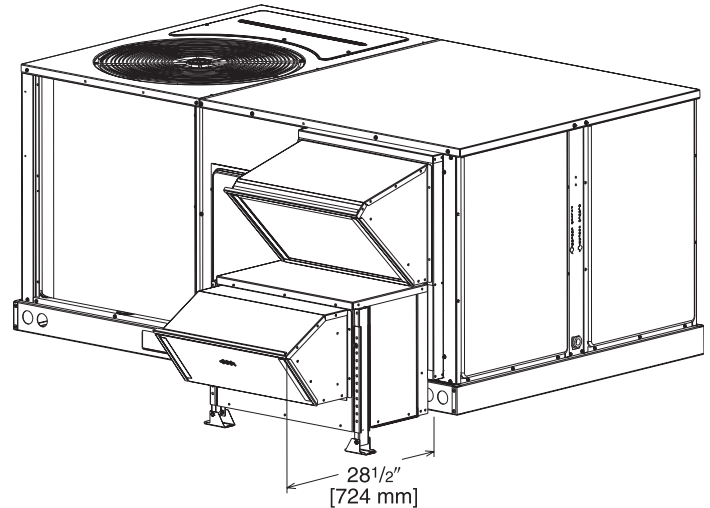

## POWER EXHAUST KIT FOR RXXRD-MECM(-) ECONOMIZERS

Model No.	No. of Fans	Volts	Phase	Watts (ea.)	High Speed		FLA (ea.)	LRA (ea.)
					CFM ①	RPM		
RXXRX-BGF04C	1	208/230	1	1000	2500	1725	4.4	23.7
RXXRX-BGF04D	1	460	1	800	2370	1620	1.8	4.1
RXXRX-BGF04Y	1	575	1	800	2370	1620	1.5	3.3

**RXXRX-BGF04C** – RLNL 3-5 Ton [10.6-17.6 kW] Models & RLPL 3-5 Ton [10.6-17.6 kW] Models  
208/230V, 1PH and 3PH, 60 Hz

**RXXRX-BGF04D** – RLNL 3-5 Ton [10.6-17.6 kW] Models & RLPL 3-5 Ton [10.6-17.6 kW] Models  
460V, 3PH, 60 Hz

**RXXRX-BGF04Y** – RLNL 3-5 Ton [10.6-17.6 kW] Models & RLPL 3-5 Ton [10.6-17.6 kW] Models  
575V, 3PH, 60 Hz

## FRESH AIR DAMPER

**RLNL 3-5 Ton [10.6-17.6 kW] Models**

**RLPL 3-5 Ton [10.6-17.6 kW] Models**

RXRF-FBA1 (Manual)

RXRF-FBB1 (Motorized)

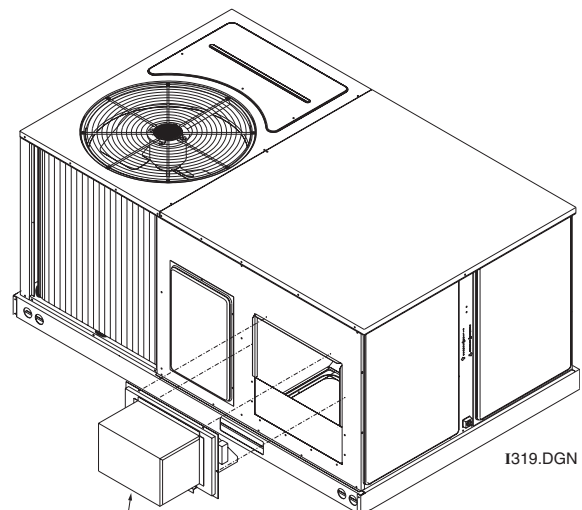

[ ] Designates Metric Conversions

FRESH AIR DAMPER

## DUCT ADAPTERS (RLNL 3 TO 5 TON [10.6 TO 17.6 kW] MODELS) (RLPL 3 TO 5 TON [10.6 TO 17.6 kW] MODELS)

### Rectangular to Round Transitions (Downflow)

Two sizes available  
(18" [457 mm] and  
20" [508 mm] round)  
fit all units. Drops  
into and secures to  
RXKG- Series Roofcurbs.

**For use with  
Concentric Diffusers.**

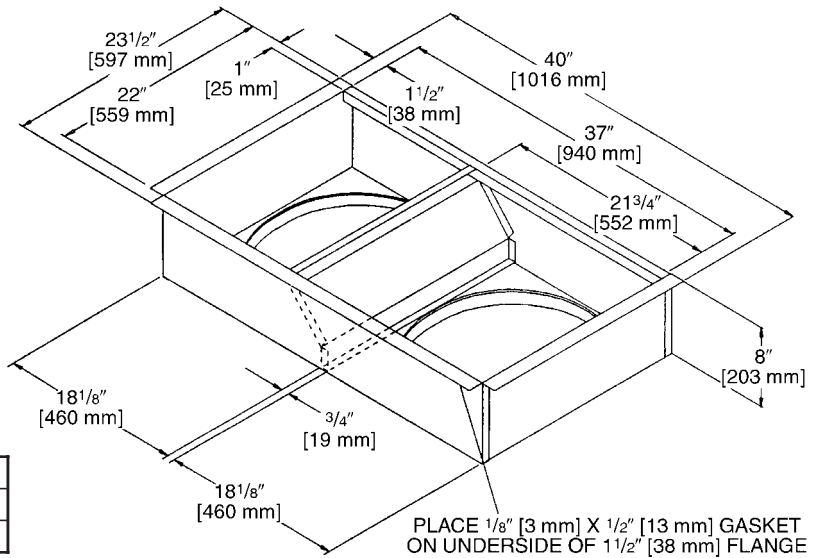

Accessory Model No.	Model Application Tons [kW]	Size in. [mm]
RXMC-CB03	3-5 [10.6-17.6]	18 [457] Round
RXMC-CB04	3-5 [10.6-17.6]	20 [508] Round

[ ] Designates Metric Conversions

### SIDE DISCHARGE CONCENTRIC DIFFUSER

RXRN-FA60 (3 to 5 Ton [10.6 to 17.6 kW] Models)  
RXRN-FA65 (3 to 7.5 Ton [10.6 to 26.4 kW] Models)

For Use With Duct Adapter (RXMC)

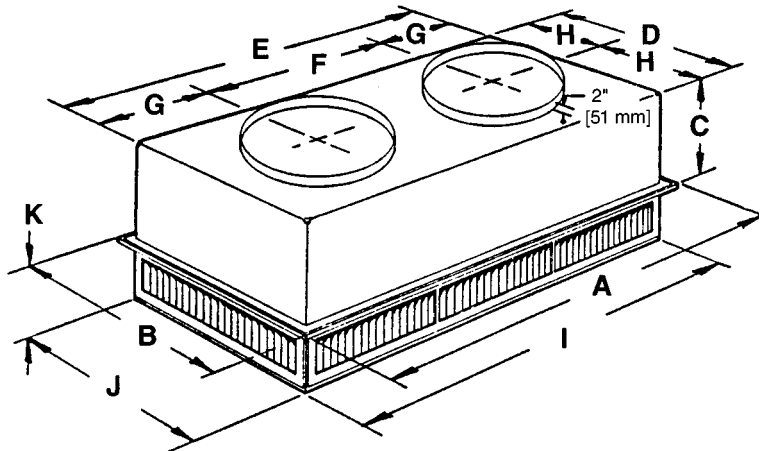

### DIMENSIONAL DATA

Model No.	A	B	C	D	E	F	G	H	I	J	K	Duct Size
RXRN-FA60	47 <sup>5</sup> / <sub>8</sub> " [1210 mm]	23 <sup>5</sup> / <sub>8</sub> " [600 mm]	11 <sup>3</sup> / <sub>8</sub> " [289 mm]	21 <sup>1</sup> / <sub>2</sub> " [546 mm]	45 <sup>1</sup> / <sub>2</sub> " [1156 mm]	22 <sup>1</sup> / <sub>2</sub> " [572 mm]	11 <sup>1</sup> / <sub>2</sub> " [292 mm]	10 <sup>3</sup> / <sub>4</sub> " [273 mm]	45 <sup>1</sup> / <sub>2</sub> " [1156 mm]	21 <sup>1</sup> / <sub>2</sub> " [546 mm]	7 <sup>1</sup> / <sub>8</sub> " [181 mm]	18RD
RXRN-FA65	47 <sup>5</sup> / <sub>8</sub> " [1210 mm]	29 <sup>5</sup> / <sub>8</sub> " [752 mm]	14 <sup>3</sup> / <sub>8</sub> " [365 mm]	27 <sup>1</sup> / <sub>2</sub> " [699 mm]	45 <sup>1</sup> / <sub>2</sub> " [1156 mm]	22 <sup>1</sup> / <sub>2</sub> " [572 mm]	11 <sup>1</sup> / <sub>2</sub> " [292 mm]	13 <sup>3</sup> / <sub>4</sub> " [349 mm]	45 <sup>1</sup> / <sub>2</sub> " [1156 mm]	27 <sup>1</sup> / <sub>2</sub> " [699 mm]	8 <sup>1</sup> / <sub>8</sub> " [206 mm]	20RD

### ENGINEERING DATA

Model No.	CFM [L/s]	Static Pressure	Throw Feet	Neck Vel.	Jet Vel.	Noise Level
RXRN-FA60	1000 [472]	.14	10-17	351	351	20
	1200 [566]	.17	11-18	421	421	20
	1400 [661]	.20	12-19	491	491	20
	1600 [755]	.24	12-20	561	561	20
	1800 [850]	.30	13-21	632	632	20
	2000 [944]	.36	14-23	702	702	20
	2200 [1038]	.40	16-25	772	772	20
RXRN-FA65	2600 [1227]	.17	24-29	669	669	20
	2800 [1321]	.20	25-30	720	720	25
	3000 [1416]	.25	27-33	772	772	25
	3200 [1510]	.31	28-35	623	623	25
	3400 [1605]	.37	30-37	874	874	30

## FLUSH MOUNT CONCENTRIC DIFFUSER

RXRN-FA70 (3 to 5 Ton [10.6 to 17.6 kW] Models)

For Use With Duct Adapter (RXMC)

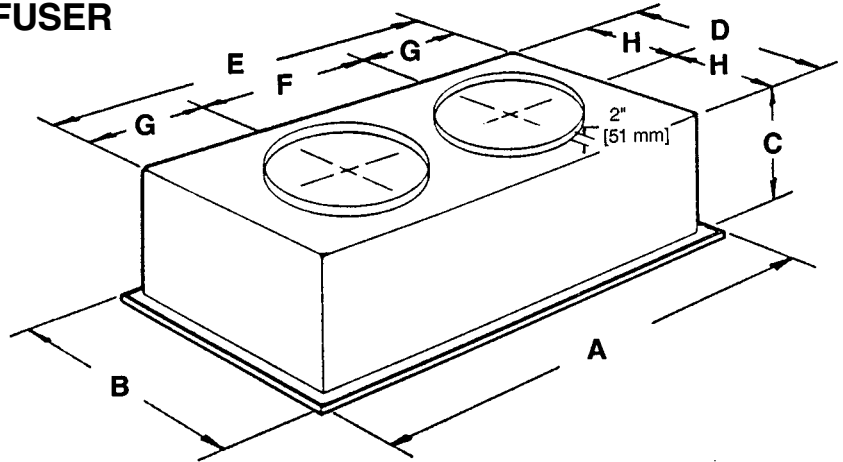

### DIMENSIONAL DATA

Model No.	A	B	C	D	E	F	G	H	Duct Size
RXRN-FA70	47 <sup>5</sup> / <sub>8</sub> " [1210 mm]	23 <sup>5</sup> / <sub>8</sub> " [600 mm]	13 <sup>1</sup> / <sub>2</sub> " [343 mm]	21" [533 mm]	45" [1143 mm]	22 <sup>1</sup> / <sub>2</sub> " [572 mm]	11 <sup>1</sup> / <sub>4</sub> " [286 mm]	10 <sup>1</sup> / <sub>2</sub> " [267 mm]	18RD
RXRN-FA75	47 <sup>5</sup> / <sub>8</sub> " [1210 mm]	29 <sup>5</sup> / <sub>8</sub> " [752 mm]	16 <sup>5</sup> / <sub>8</sub> " [442 mm]	27" [666 mm]	45" [1143 mm]	22 <sup>1</sup> / <sub>2</sub> " [572 mm]	11 <sup>1</sup> / <sub>4</sub> " [286 mm]	13 <sup>1</sup> / <sub>2</sub> " [343 mm]	20RD

### ENGINEERING DATA

Model No.	CFM [L/s]	Static Pressure	Throw Feet	Neck Vel.	Jet Vel.	Noise Level
RXRN-FA70	1000 [472]	.14	15-20	391	694	20
	1200 [566]	.17	16-22	469	833	25
	1400 [661]	.20	17-24	547	972	30
	1600 [755]	.24	18-25	625	1111	30
	1800 [850]	.30	20-28	703	1250	35
	2000 [944]	.36	21-29	781	1389	40
	2200 [1038]	.40	22-30	859	1528	40
RXRN-FA75	2600 [1227]	.17	19-24	663	1294	30
	2800 [1321]	.20	20-28	714	1393	35
	3000 [1416]	.25	21-29	765	1492	35
	3200 [1510]	.31	22-29	616	1592	40
	3400 [1605]	.37	22-30	667	1692	40

[ ] Designates Metric Conversions



## SAMPLE SPECIFICATIONS

Unit shall be completely factory assembled and performance tested to provide the required cooling and heating functions suitable for outdoor installations. Unit shall be UL/cUL listed and rated in accordance to AHRI Standard 210.

### Cabinet

Unit casing, base pan and framework shall be manufactured of galvanized sheet metal primed and finished with powder paint capable of withstanding a 1000-hour salt spray test per ASTM B 117. Unit interior cabinet surfaces shall be insulated with a minimum 1/2-inch thick foil faced insulation. Access panels shall be easily removable providing access to the blower, filter, heating compartment, and compressor/control box. Unit base rails shall be provided with fork insertion slots and rigging holes. Condensate drain pan shall be of sloped design to conform to ASHRAE 62. Unit shall be supplied ready for vertical airflow and be easily convertible to horizontal airflow at or before installation.

### Compressor(s)

Unit shall be provided with fully hermetic scroll compressor(s) with internally protected safety controls.

### Coils

The evaporator and condenser coils shall be fabricated of copper tubes with mechanically bonded aluminum plate fins. They shall be pressure tested prior to assembly into the unit, and electronically leak tested after assembly.

### Condenser Fan

A single direct drive propeller fan shall discharge air vertically upward. The fan motor shall be permanently lubricated and have built-in overload protection.

### Evaporator Blower

A single, double inlet, centrifugal wheel shall rotate in permanently lubricated ball bearings. The wheel shall be made from steel with corrosion resistant finish and shall be statically and dynamically balanced.

## ACCESSORIES

### ROOF CURB

Curb shall be full perimeter type, complying with the standards of the National Roofing Contractors Association. Design shall provide for drop-in of supply and return ducts prior to setting unit, and include an insulating panel for the rest of the curb area.

### Economizer

Economizer shall be completely assembled for field installation. Unit shall include all controls and dampers including the barometric relief damper.

### Manual Fresh Air Damper

Damper shall consist of damper and rainhood which is manually preset to admit up to 35% of outside air for field installation.

### Motorized Fresh Air Damper

Damper shall consist of motor, damper, and rainhood which can admit up to 35% of outside air for field installation.

### Electric Heat Kits

Electric heat kits shall be available in a wide range of capacity with branch circuit fusing allowing single point wiring. Kits shall be UL/cUL approved. Each kit shall be offered as a field or factory installed option.

### Pressure Controls

High and low pressure controls shall be included for field or factory installation.

### Low Ambient Control

Low ambient control shall be provided to cycle the condenser fan in response to condensing pressure and allow operation to 0 degrees F. The option shall be field or factory installed.

### Time Delay Control

Time delay control shall be provided to prevent the compressor from restarting 5 minutes after shutdown. The control shall be field or factory installed.

### Louver Panel Kits

Field or factory installed louver kits shall be provided for condenser coil protection against hail or flying debris.

WIRING SCHEMATIC

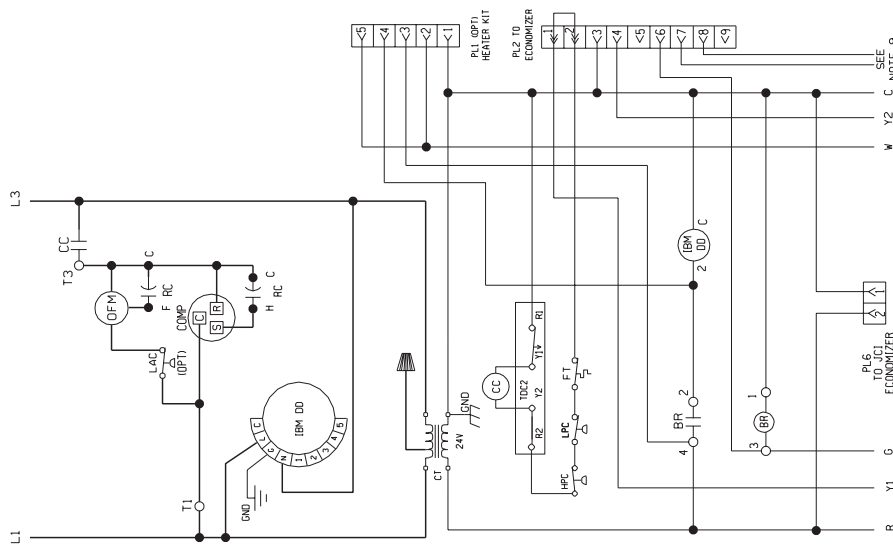

WIRING DIAGRAM

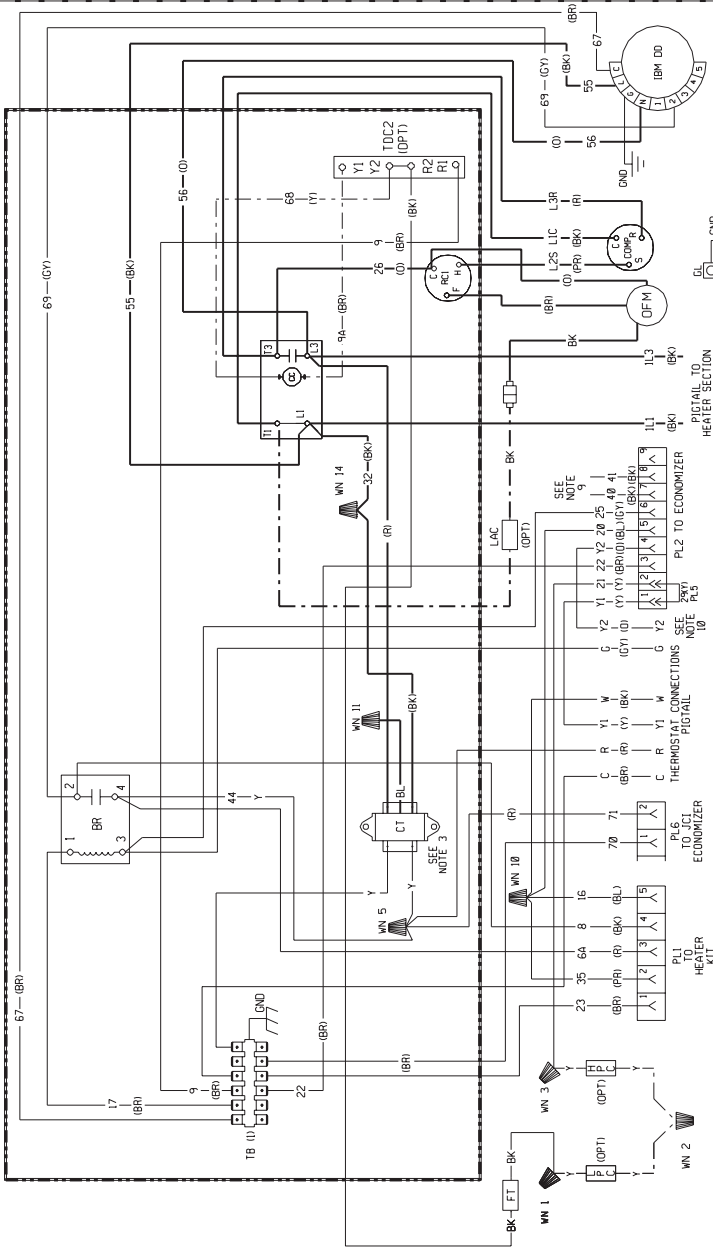

SEE "DETAIL A" FOR FACTORY SETTINGS. SEE NOTE 7

PIGTAIL TO HEATER SECTION

SEE NOTE 9

SEE NOTE 10

SEE NOTE 11

SEE NOTE 12

**DETAIL A\***

NOMINAL COOLING CAPACITY	MOTOR SPEED FROM FACTORY		AVAILABLE SPEEDS	
	HEAT (TAP 2)	COOL (TAP 2)	LOW (TAP 2)	HIGH (TAP 2)
3 TON	LOW (TAP 2)	LOW (TAP 2)	LOW (TAP 2)	HIGH (TAP 4)
3.5, 4 TON	MED (TAP 2)	MED (TAP 2)	MED (TAP 2)	MED (TAP 2)
5 TON	MED (TAP 2)	MED (TAP 2)	MED (TAP 2)	HIGH (TAP 3)

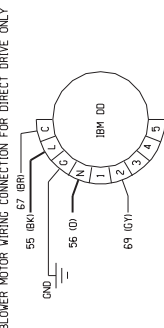

**WIRE COLOR CODE**

BK	BLACK	GY	GRAY	R	RED
BR	BROWN	O	ORANGE	W	WHITE
BL	BLUE	PK	PINK	Y	YELLOW
G	GREEN	PR	PURPLE		

**WIRING INFORMATION**

- LINE VOLTAGE
- FACTORY STANDARD
- FACTORY OPTION
- FACTORY INSTALLED
- LOW VOLTAGE
- FACTORY STANDARD
- FACTORY OPTION
- FACTORY INSTALLED
- REPLACEMENT WIRE
- MUST BE THE SAME SIZE AND TYPE OF INSULATION AS ORIGINAL (1005 C MIN.)
- CABINET MUST BE PERMANENTLY GROUNDED AND CONFORM TO I.E.C., N.E.C., C.E.C. AND LOCAL CODES AS APPLICABLE.

**NOTES:**

- CONNECTORS SUITABLE FOR USE WITH COPPER CONDUCTORS ONLY. COMPRESSOR MOTOR THERMALLY PROTECTED. ALL 3 PHASE MODELS MUST BE USED WITH 3 PHASE SUPPLY.
- CONTROL TRANSFORMER PRIMARY LEADS: RED-COM, BLUE-208V, BLACK-230V. TRANSFORMER FACTORY WIRING FOR 230 VOLTS ON J & C MODELS. INTERCHANGE BLACK & BLUE LEADS FOR 208 V.
- CONTACTOR FACTORY WIRING: CONNECT FIELD WIRE TO FACTORY SUPPLIED PIGTAIL.
- LOW VOLTAGE CIRCUIT IS N.E.C. CLASS 2 WITH A CLASS 2 FUSED DISCONNECT.
- CONNECT FIELD WIRING IN GROUNDED RAIN TIGHT CONDUIT TO 60 HZ MOTOR.
- MOTOR FACTORY WIRING FOR CORRECT SPEED.
- FIELD WIRING ON UNIT FUSE BOX FOR FUSE SIZING AND CLASSIFICATION.
- WIRE FROM PL2 (7 & 8) GO TO THE MIXED AIR SENSOR ON THE OPTIONAL ECONOMIZER.
- WIRE 15 USED ONLY FOR THE OPTIONAL ECONOMIZER.

**COMPONENT CODE**

BR	BLOWER RELAY
CC	COMPRESSOR CONTACTOR
CDMP	COMPRESSOR
CT	CONTROL TRANSFORMER
FT	FREIZE STAT
GND	GROUND LUG
HPC	HIGH PRESSURE CONTROL
IBMOD	INDOOR BLOWER MOTOR DIRECT DRIVE
LAC	LOW AMBIENT COOLING CONTROL
LFC	LOW PRESSURE CONTROL
LPG	INDOOR FAN MOTOR
PL	PLUG
PC	RUN CAPACITOR
TB	TERMINAL BLOCK (LOW VOLTAGE)
TDC	TIME DELAY CONTROL
WN	WIRE NUT

**ELECTRICAL WIRING DIAGRAM**  
208 / 230V, 1 PHASE  
DIRECT DRIVE / X-MOTOR  
PACKAGE AIR CONDITIONER

DR. BY DATE DWG. NO. REV  
MCB 5-02-05 90-23597-11 02

DWG. NO. 90-23597-11 REV 02

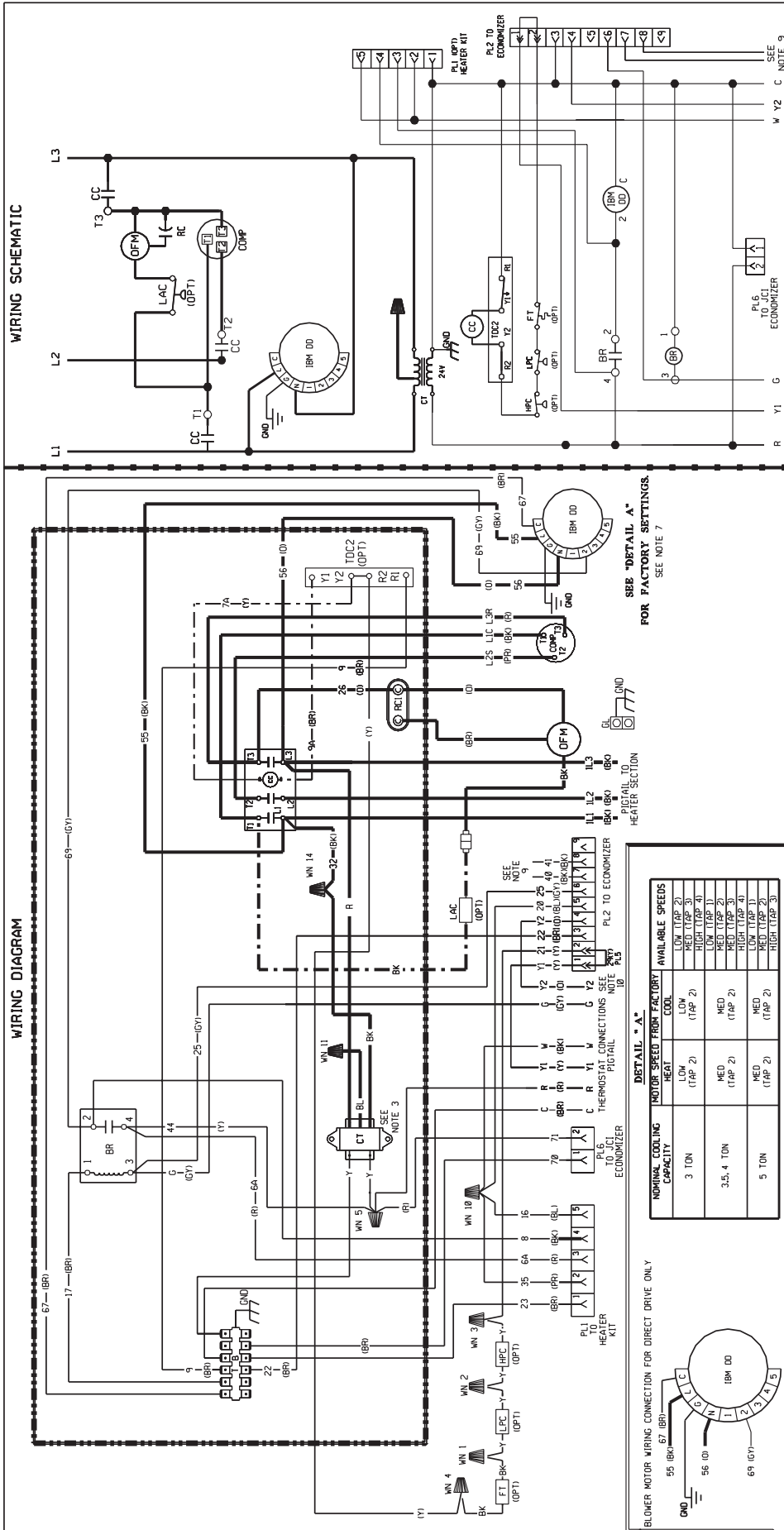

WIRING SCHEMATIC

WIRING DIAGRAM

**WIRE COLOR CODE**

BK...BLACK GY...GRAY R...RED  
 BR...BROWN O...ORANGE W...WHITE  
 BL...BLUE PK...PINK Y...YELLOW  
 G...GREEN PR...PURPLE

**ELECTRICAL WIRING DIAGRAM**  
 208 / 230 / 460V, 3 PHASE  
 DIRECT DRIVE/X-MOTOR  
 PACKAGE AIR CONDITIONER

---

**WIRING INFORMATION**

LINE VOLTAGE  
 -FACTORY STANDARD  
 -FACTORY OPTION  
 -FIELD INSTALLED  
 LOW VOLTAGE  
 -FACTORY STANDARD  
 -FACTORY OPTION  
 RE-PLACEMENT WIRE  
 -MUST BE THE SAME SIZE AND TYPE OF INSULATION AS ORIGINAL (105 C MIN.)  
 -CABINET MUST BE PERMANENTLY GROUNDED AND CONFORM TO I.E.C., N.E.C., C.E.C. AND LOCAL CODES AS APPLICABLE.

**WIRE COLOR CODE**

BK...BLACK GY...GRAY R...RED  
 BR...BROWN O...ORANGE W...WHITE  
 BL...BLUE PK...PINK Y...YELLOW  
 G...GREEN PR...PURPLE

---

**NOTES:**

- CONNECTORS SUITABLE FOR USE WITH COPPER CONDUCTORS ONLY. COMPRESSOR MOTOR THERMAL PROTECTED. PHASING LABELS ARE PROTECTED UNDER PRIMARY SINGLE PHASE CONDITIONS.
- CONTROL TRANSFORMER PRIMARY LEADS: RED/BLACK, BLUE-208V, BLACK-230V, BLACK/RED-460V. BLACK/BLUE-575V. TRANSFORMER FACTORY WIRED FOR 230 VOLTS. IF 208V OR 460V IS DESIRED, INTERCHANGE BLACK & BLUE WIRE FOR CORRECT VOLTAGE.
- 50 AMP COMMON BLUE-389V, BLACK-415V.
- CONTACTOR FACTORY WIRED CONNECT FIELD WIRE TO FACTORY SUPPLIED PITGAL.
- LOW VOLTAGE CIRCUIT IS N.E.C. CLASS 2 WITH A CLASS 2 CONNECT FIELD WIRING IN GROUNDED RAIN TIGHT CONDUIT TO 60 HZ FUSED DISCONNECT.
- MOTOR FACTORY WIRED FOR CORRECT SPEED.
- CLASSIFICATION ON UNIT FUSE BOX FOR FUSE SIZING AND OPTIONAL ECONOMIZER.
- WIRES FROM PL2 (7 & 8) GO TO THE MIXED AIR SENSOR ON THE ECONOMIZER.
- 10, 12 IS USED ONLY FOR THE OPTIONAL ECONOMIZER.

**DETAIL "A"**

NOMINAL COOLING CAPACITY	MOTOR SPEED FROM FACTORY AVAILABLE SPEEDS		
	HEAT	COOL	
3 TON	LOW (TAP 2)	LOW (TAP 2)	LOW (TAP 2)
	MED (TAP 2)	MED (TAP 2)	MED (TAP 2)
	HIGH (TAP 2)	HIGH (TAP 2)	HIGH (TAP 2)
3.5 & 4 TON	LOW (TAP 2)	LOW (TAP 2)	LOW (TAP 2)
	MED (TAP 2)	MED (TAP 2)	MED (TAP 2)
	HIGH (TAP 2)	HIGH (TAP 2)	HIGH (TAP 2)
5 TON	LOW (TAP 2)	LOW (TAP 2)	LOW (TAP 2)
	MED (TAP 2)	MED (TAP 2)	MED (TAP 2)
	HIGH (TAP 2)	HIGH (TAP 2)	HIGH (TAP 2)

---

**COMPONENT CODE**

BR...BLOWER RELAY CONTACTOR  
 COMP...COMPRESSOR  
 CT...CONTROL TRANSFORMER  
 FT...FREEZE STAT  
 CLD...GROUND LUG  
 HPC...HIGH PRESSURE CONTROL  
 IBMDD...INDOOR BLOWER MOTOR DIRECT DRIVE  
 LPC...LOW AMBIENT COOLING CONTROL  
 OPM...OUTDOOR FAN MOTOR  
 PL...RUN CAPACITOR  
 TB...TERMINAL BLOCK (LOW VOLTAGE)  
 TDC...TIME DELAY CONTROL  
 WN...WIRE NUT

**DETAIL "A"**

BLOWER MOTOR WIRING CONNECTION FOR DIRECT DRIVE ONLY

---

**FACTORY SETTINGS**

SEE NOTE 7

**WIRING INFORMATION**

LINE VOLTAGE  
 -FACTORY STANDARD  
 -FACTORY OPTION  
 -FIELD INSTALLED  
 LOW VOLTAGE  
 -FACTORY STANDARD  
 -FACTORY OPTION  
 RE-PLACEMENT WIRE  
 -MUST BE THE SAME SIZE AND TYPE OF INSULATION AS ORIGINAL (105 C MIN.)  
 -CABINET MUST BE PERMANENTLY GROUNDED AND CONFORM TO I.E.C., N.E.C., C.E.C. AND LOCAL CODES AS APPLICABLE.

---

**WIRING INFORMATION**

LINE VOLTAGE  
 -FACTORY STANDARD  
 -FACTORY OPTION  
 -FIELD INSTALLED  
 LOW VOLTAGE  
 -FACTORY STANDARD  
 -FACTORY OPTION  
 RE-PLACEMENT WIRE  
 -MUST BE THE SAME SIZE AND TYPE OF INSULATION AS ORIGINAL (105 C MIN.)  
 -CABINET MUST BE PERMANENTLY GROUNDED AND CONFORM TO I.E.C., N.E.C., C.E.C. AND LOCAL CODES AS APPLICABLE.

**WIRE COLOR CODE**

BK...BLACK GY...GRAY R...RED  
 BR...BROWN O...ORANGE W...WHITE  
 BL...BLUE PK...PINK Y...YELLOW  
 G...GREEN PR...PURPLE

---

**NOTES:**

- CONNECTORS SUITABLE FOR USE WITH COPPER CONDUCTORS ONLY. COMPRESSOR MOTOR THERMAL PROTECTED. PHASING LABELS ARE PROTECTED UNDER PRIMARY SINGLE PHASE CONDITIONS.
- CONTROL TRANSFORMER PRIMARY LEADS: RED/BLACK, BLUE-208V, BLACK-230V, BLACK/RED-460V. BLACK/BLUE-575V. TRANSFORMER FACTORY WIRED FOR 230 VOLTS. IF 208V OR 460V IS DESIRED, INTERCHANGE BLACK & BLUE WIRE FOR CORRECT VOLTAGE.
- 50 AMP COMMON BLUE-389V, BLACK-415V.
- CONTACTOR FACTORY WIRED CONNECT FIELD WIRE TO FACTORY SUPPLIED PITGAL.
- LOW VOLTAGE CIRCUIT IS N.E.C. CLASS 2 WITH A CLASS 2 CONNECT FIELD WIRING IN GROUNDED RAIN TIGHT CONDUIT TO 60 HZ FUSED DISCONNECT.
- MOTOR FACTORY WIRED FOR CORRECT SPEED.
- CLASSIFICATION ON UNIT FUSE BOX FOR FUSE SIZING AND OPTIONAL ECONOMIZER.
- WIRES FROM PL2 (7 & 8) GO TO THE MIXED AIR SENSOR ON THE ECONOMIZER.
- 10, 12 IS USED ONLY FOR THE OPTIONAL ECONOMIZER.

**DETAIL "A"**

NOMINAL COOLING CAPACITY	MOTOR SPEED FROM FACTORY AVAILABLE SPEEDS		
	HEAT	COOL	
3 TON	LOW (TAP 2)	LOW (TAP 2)	LOW (TAP 2)
	MED (TAP 2)	MED (TAP 2)	MED (TAP 2)
	HIGH (TAP 2)	HIGH (TAP 2)	HIGH (TAP 2)
3.5 & 4 TON	LOW (TAP 2)	LOW (TAP 2)	LOW (TAP 2)
	MED (TAP 2)	MED (TAP 2)	MED (TAP 2)
	HIGH (TAP 2)	HIGH (TAP 2)	HIGH (TAP 2)
5 TON	LOW (TAP 2)	LOW (TAP 2)	LOW (TAP 2)
	MED (TAP 2)	MED (TAP 2)	MED (TAP 2)
	HIGH (TAP 2)	HIGH (TAP 2)	HIGH (TAP 2)

---

**COMPONENT CODE**

BR...BLOWER RELAY CONTACTOR  
 COMP...COMPRESSOR  
 CT...CONTROL TRANSFORMER  
 FT...FREEZE STAT  
 CLD...GROUND LUG  
 HPC...HIGH PRESSURE CONTROL  
 IBMDD...INDOOR BLOWER MOTOR DIRECT DRIVE  
 LPC...LOW AMBIENT COOLING CONTROL  
 OPM...OUTDOOR FAN MOTOR  
 PL...RUN CAPACITOR  
 TB...TERMINAL BLOCK (LOW VOLTAGE)  
 TDC...TIME DELAY CONTROL  
 WN...WIRE NUT

**DETAIL "A"**

BLOWER MOTOR WIRING CONNECTION FOR DIRECT DRIVE ONLY

## WIRING SCHEMATIC

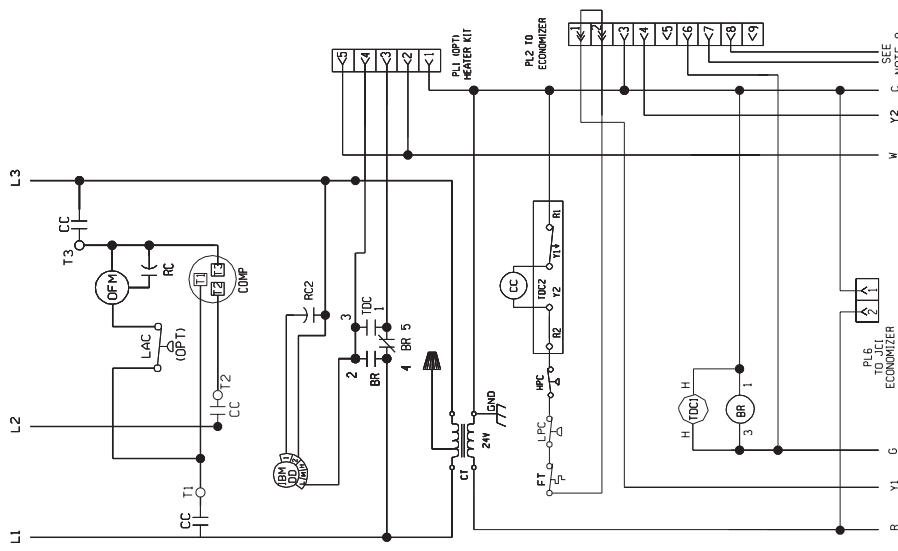

## WIRING DIAGRAM

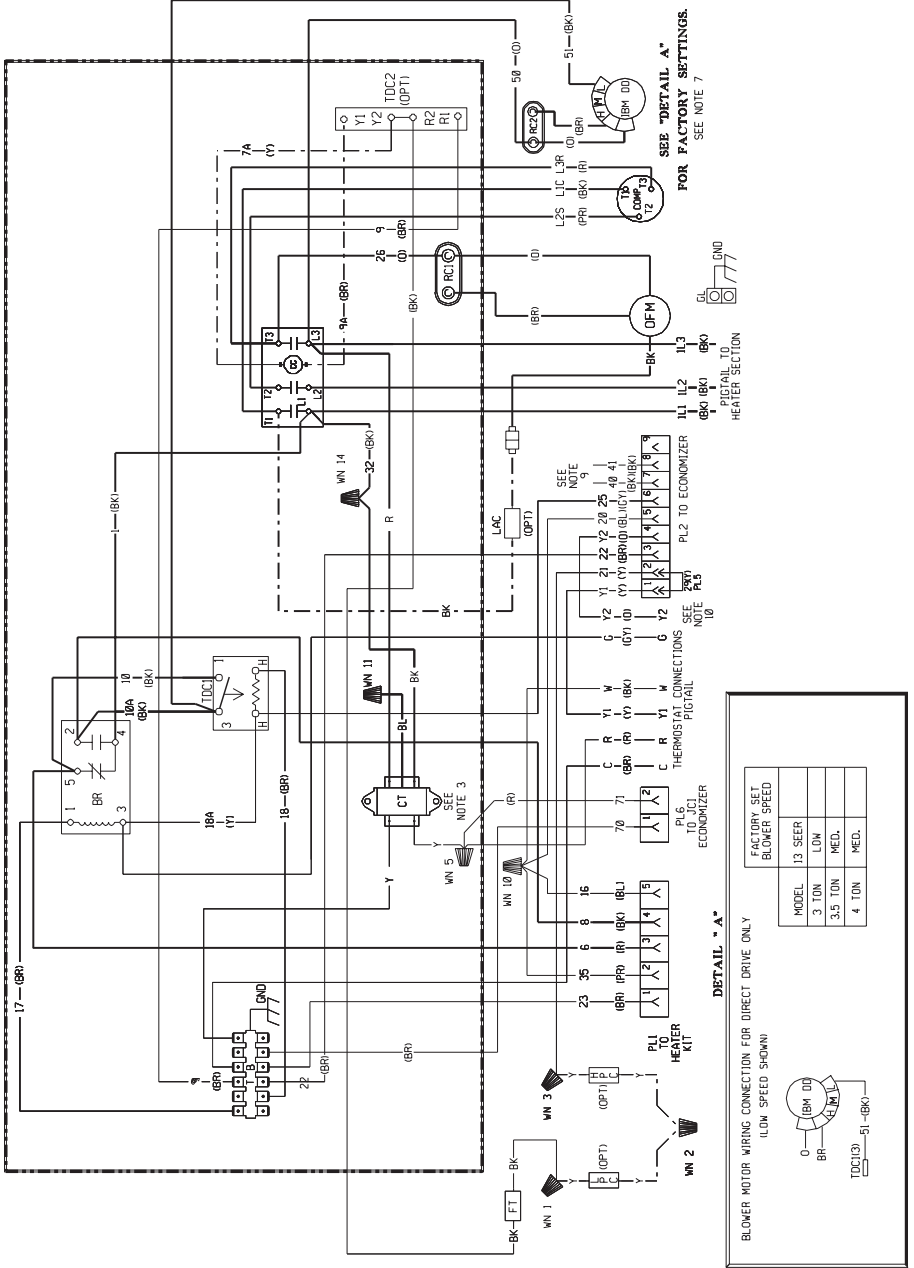

FOR FACTORY SETTINGS.  
SEE NOTE 7

DETAIL "A"



MODEL	13 SEER	16 SEER	18 SEER
3 TON	LOW	MED.	MED.
3.5 TON	LOW	MED.	MED.
4 TON	LOW	MED.	MED.

## COMPONENT CODE

- BR BLOWER RELAY
- CC COMPRESSOR CONTACTOR
- COMP COMPRESSOR
- CT CONTROL TRANSFORMER
- FT FREEZE STAT
- GND GROUND
- LUG LUG
- HPC HIGH PRESSURE CONTROL
- IDMDD INDUCED DRAFT MOTOR DIRECT DRIVE
- LAC LOW AMBIENT COOLING CONTROL
- LFC LOW PRESSURE CONTROL
- LPM LOW PRESSURE MOTOR
- PLM PLUG
- RC RUN CAPACITOR
- RB TERMINAL BLOCK (LOW VOLTAGE)
- TBC TIME DELAY CONTROL
- WN WIRE NUT

## NOTES:

1. CONNECTORS SUITABLE FOR USE WITH COPPER CONDUCTORS ONLY.
2. COMPRESSOR MOTOR THERMALLY PROTECTED. ALL 3 PHASE MODELS.
3. CONTROL TRANSFORMER PRIMARY LEADS: RED-COM, BLUE-208V, BLACK-230V. TRANSFORMER FACTORY WIRED FOR 230 VOLTS ON J1 & C MODELS. INTERCHANGE BLACK & BLUE LEADS FOR 208 VOLTAGE.
4. CONTACTOR FACTORY WIRED. CONNECT FIELD WIRE TO FACTORY SUPPLIED PITTAGAL.
5. LOW VOLTAGE CIRCUIT IS N.E.C. CLASS 2 WITH A CLASS 2 SUPPLY.
6. CONNECT FIELD WIRING IN GROUNDED RAIN TIGHT CONDUIT TO 60 HZ FUSED DISCONNECT.
7. WIRE FACTORY WIRING FOR CORRECT SPEED.
8. CLASSIFICATION ON UNIT FUSE BOX FOR FUSE SIZING AND DISCONNECT.
9. WIRES FROM PL2 17 & 81 GO TO THE MIXED AIR SENSOR ON THE OPTIONAL ECONOMIZER.
10. Y2 IS USED ONLY FOR THE OPTIONAL ECONOMIZER.

## WIRING INFORMATION

- LINE VOLTAGE
- FACTORY STANDARD
- FACTORY OPTION
- FIELD INSTALLED
- LOW VOLTAGE
- FACTORY STANDARD
- FACTORY OPTION
- FIELD INSTALLED
- REPLACEMENT WIRE
- MUST BE THE SAME SIZE AND TYPE OF INSULATION AS ORIGINAL (105 C MIN.)
- CABINET MUST BE PERMANENTLY GROUNDED AND CONFORM TO I.E.C., N.E.C., C.E.C. AND LOCAL CODES AS APPLICABLE.

## WIRE COLOR CODE

- BK---BLACK
- BR---BROWN
- BL---BLUE
- G---GREEN
- GY---GRAY
- O---ORANGE
- PK---PINK
- PR---PURPLE
- R---RED
- W---WHITE
- Y---YELLOW

## ELECTRICAL WIRING DIAGRAM 208 / 230, 3 PHASE DIRECT DRIVE PACKAGE AIR CONDITIONER



WIRING SCHEMATIC

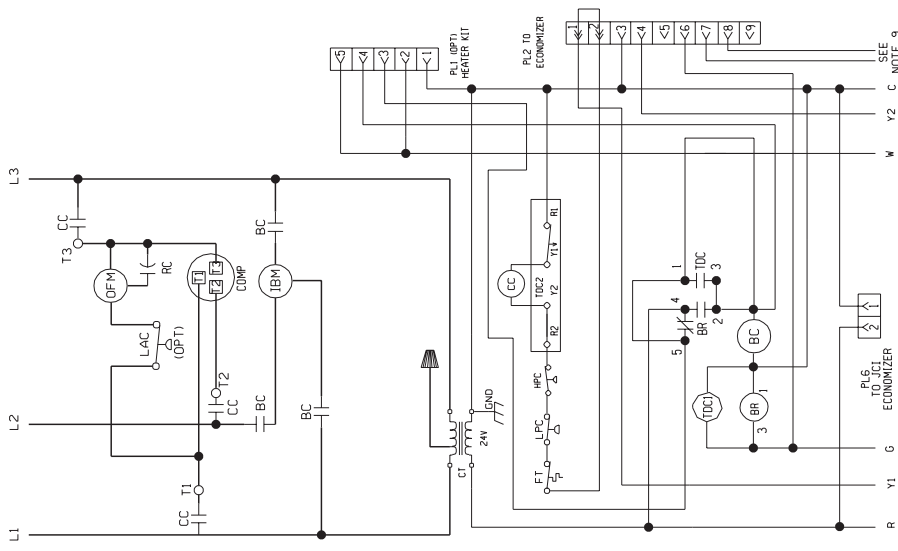

WIRING DIAGRAM

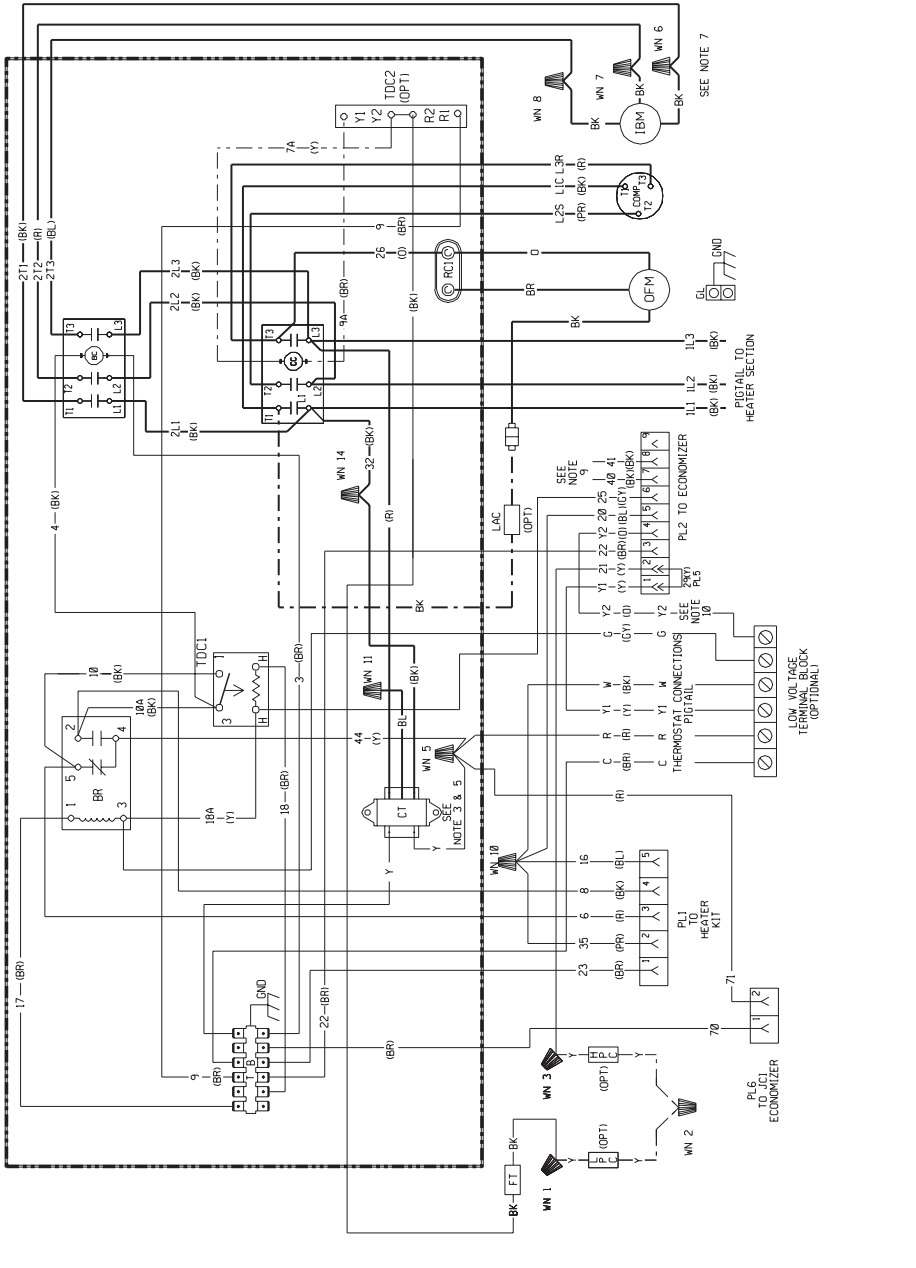

WIRE COLOR CODE

BK	BLACK	GY	GRAY	R	RED
BR	BROWN	O	ORANGE	W	WHITE
BL	BLUE	PK	PINK	Y	YELLOW
G	GREEN	PR	PURPLE		

ELECTRICAL WIRING DIAGRAM  
208/230/460/575V, 3 PHASE 60 HZ.  
BELT DRIVE  
PACKAGE AIR CONDITIONER

WIRING INFORMATION

LINE VOLTAGE  
-FACTORY STANDARD  
-FACTORY OPTION  
-FIELD INSTALLED

LOW VOLTAGE  
-FACTORY STANDARD  
-FACTORY OPTION  
-FIELD INSTALLED

REPLACEMENT WIRE  
-MUST BE THE SAME SIZE AND TYPE OF INSULATION AS ORIGINAL (105 C° MIN.)  
-CABINET MUST BE PERMANENTLY GROUNDED AND CONFORM TO I.E.C., N.E.C., C.E.C. AND LOCAL CODES AS APPLICABLE.

- NOTES:
- CONNECTORS SUITABLE FOR USE WITH COPPER CONDUCTORS ONLY. COMPRESSOR MOTOR THERMALLY PROTECTED. ALL 3 PHASE MODELS MUST BE USED WITH 3 PHASE SUPPLY.
  - CONTROL TRANSFORMER PRIMARY LEADS: RED-COM., BLUE-208V, 460V, 575V; BLACK-BLUE-575V; TRANSFORMER FACTORY WIRE FOR 230 VOLTS ON V1 & V2 MODELS; INTERCHANGE BLACK & BLUE LEADS FOR 208 VOLT OPERATION. 460 & 575 VOLT MODELS FACTORY WIRE FOR CORRECT VOLTAGE.
  - CONNECTOR COMMON BLUE-380V, BLACK-419V.
  - SUPPLIED PIGTAIL KIT IS N.E.C. CLASS 2 WITH A CLASS 2 TRANSFORMER. 24V/50/40 HZ SUPPLIED.
  - CONNECT FIELD WIRING IN GROUNDED RAIN TIGHT CONDUIT TO 60 HZ FUSED DISCONNECT WIRE FOR CORRECT SIZED.
  - SEE FUSE LABEL ON UNIT FUSE BOX FOR FUSE SIZING AND CLASSIFICATION.
  - WIRES FROM PL2 V1 & 81 GO TO THE MIXED AIR SENSOR ON THE HEATER SECTION.
  - Y2 IS USED ONLY FOR THE OPTIONAL ECONOMIZER.

COMPONENT CODE

BLW BLOWER MOTOR  
BC COMPRESSOR CONTACTOR  
COMP COMPRESSOR  
CT CONTROL TRANSFORMER  
FT FREEZE STAT  
GND GROUND LUG  
HPC HIGH PRESSURE CONTROL  
IBMD INDOOR BLOWER MOTOR BELT DRIVE  
LAC LOW AMBIENT COOLING CONTROL  
LPC LOW PRESSURE CONTROL  
OFM OUTDOOR FAN MOTOR  
PC RUN CAPACITOR  
TB TERMINAL BLOCK (LOW VOLTAGE)  
TDC TIME DELAY CONTROL  
WN WIRE NUT

DWG. NO. 90-23597-14  
REV 01

WIRING SCHEMATIC

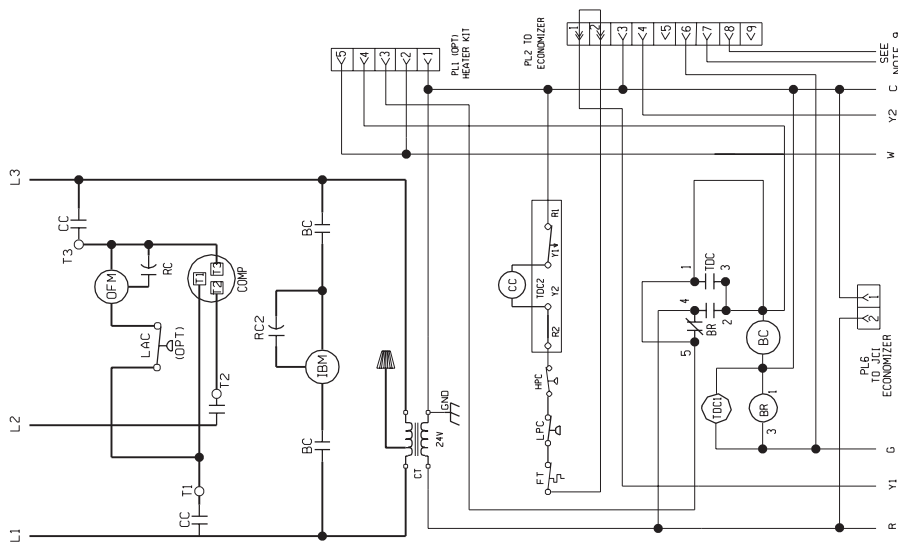

WIRING DIAGRAM

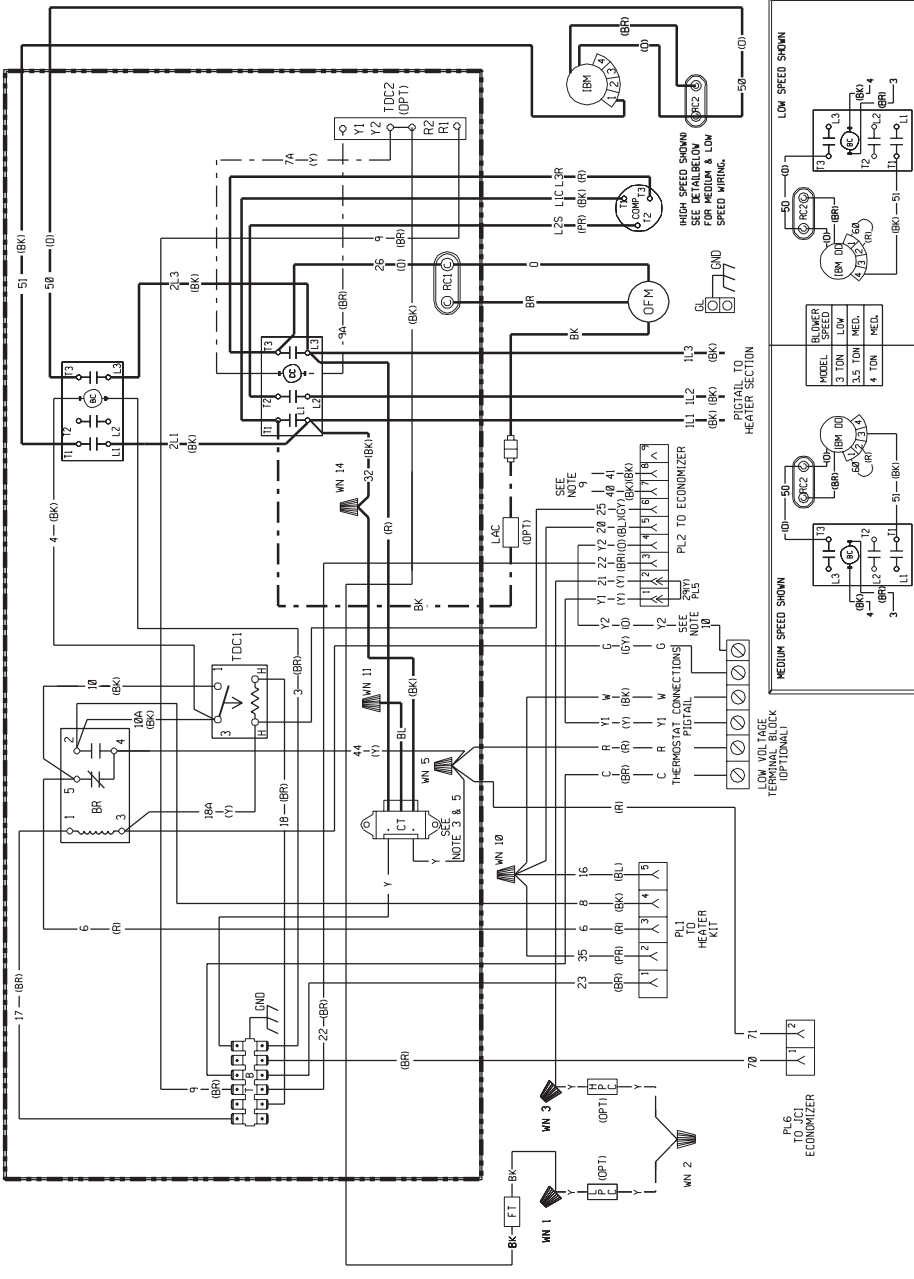

<p><b>WIRING INFORMATION</b></p> <p>LINE VOLTAGE          -FACTORY STANDARD          -FACTORY OPTION          -FIELD INSTALLED</p> <p>LOW VOLTAGE          -FACTORY STANDARD          -FACTORY OPTION          -FIELD INSTALLED</p> <p>REPLACEMENT WIRE          -MUST BE THE SAME SIZE AND TYPE OF INSULATION AS ORIGINAL (105 C° MIN.)</p> <p>WARNING          -CABINET MUST BE PERMANENTLY GROUNDED AND CONFORM TO I.E.C., N.E.C., C.E.C. AND LOCAL CODES AS APPLICABLE.</p>		<p><b>WIRE COLOR CODE</b></p> <p>BK__BLACK    GY__GRAY    R__RED          BR__BROWN    O__ORANGE    W__WHITE          BL__BLUE    PK__PINK    Y__YELLOW          G__GREEN    PR__PURPLE</p>			
<p><b>NOTES:</b></p> <ol style="list-style-type: none"> <li>CONNECTORS SUITABLE FOR USE WITH COPPER CONDUITS ONLY. COMPRESSOR MOTOR TERMINALS PROTECTED UNDER PHASE MODELS.</li> <li>ARE PROTECTED UNDER PRIMARY SINGLE PHASE CONDITIONS.</li> <li>CONTROL TRANSFORMER PRIMARY LEADS:              BLACK-230V, BLACK/RED-460V, BLACK/BLUE-575V, TRANSFORMER FACTORY WIRE FOR 230 VOLTS ON "Y" &amp; "C" MODELS, INTERCHANGE BLACK/BLUE LEADS FOR 208V OPERATION, 460 &amp; 575 VOLT MODELS* FACTORY WIRE FOR CORRECT VOLTAGE.              BLUE-208V              ORANGE-COMMON BLUE-380V, BLACK-415V.</li> <li>SUPPLIED PITTAGAL WIRE, CONNECT FIELD WIRE TO FACTORY WIRE.</li> <li>TRANSFORMER WIRING IN GROUNDED RAIN TIGHT CONDUIT TO 60 HZ.</li> <li>LOW VOLTAGE CIRCUIT IS N.E.C. CLASS 2 WITH A CLASS 2 FUSE DISCONNECT.</li> <li>MOTOR CAPACITOR WIRING FOR CORRECT SPEED.</li> <li>SEE FUSE LABEL ON UNIT FUSE BOX FOR FUSE SIZING AND WIRE FROM PL2 (7 &amp; 8) TO THE MIXED AIR SENSOR ON THE OPTIONAL ECONOMIZER.</li> <li>Y, Z IS USED ONLY FOR THE OPTIONAL ECONOMIZER.</li> </ol>		<p><b>ELECTRICAL WIRING DIAGRAM</b></p> <p>460V, 3 PHASE 60 HZ.          DIRECT DRIVE          PACKAGE AIR CONDITIONER</p>			
<p><b>COMPONENT CODE</b></p> <p>BC BLOWER MOTOR          BR BLOWER CONTACTOR          CC COMPRESSOR          CT FAN MOTOR TRANSFORMER          CL FAN MOTOR          GND GROUND LUG          HFC HIGH PRESSURE CONTROL          IBMD INDOOR BLOWER MOTOR BELT DRIVE          LAC LAMP CAPACITOR          LPC LOW PRESSURE CONTROL          OFM OUTDOOR FAN MOTOR          PL PLUG          RC RUN CAPACITOR          TB TERMINAL BLOCK (LOW VOLTAGE)          T THERMOSTAT          YC Y-CIRCUIT CONTROL          WN WIRE NUT</p>	<p><b>COMPONENT CODE</b></p> <p>PL1 HEATER KIT          PLS TO ECONOMIZER          TDC1          TDC2 (OPT)</p>	<p><b>WIRE COLOR CODE</b></p> <p>BK__BLACK    GY__GRAY    R__RED          BR__BROWN    O__ORANGE    W__WHITE          BL__BLUE    PK__PINK    Y__YELLOW          G__GREEN    PR__PURPLE</p>			
<p>DWG. NO. 90-23597-15</p>	<p>REV 02</p>	<p>DATE 5-19-05</p>	<p>DR. BY MCB</p>	<p>DWG. NO. 90-23597-15</p>	<p>REV 02</p>



WIRING SCHEMATIC

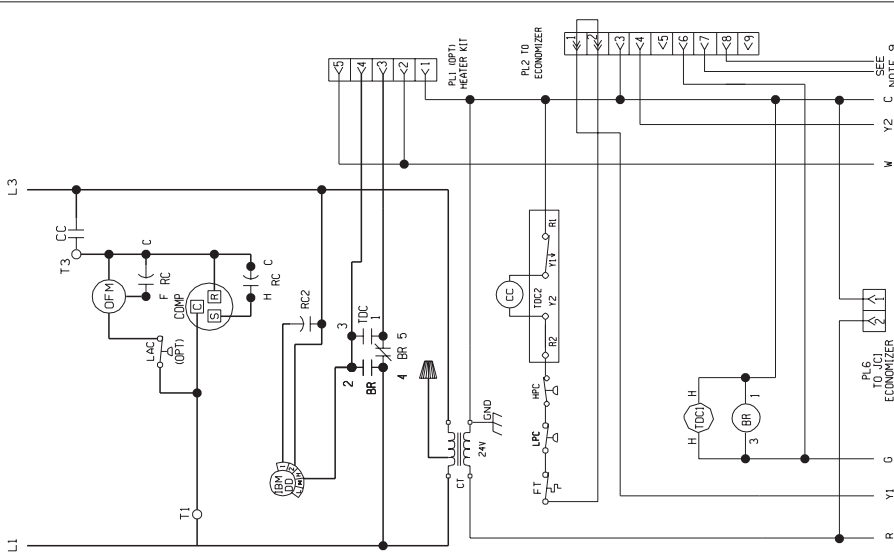

WIRING DIAGRAM

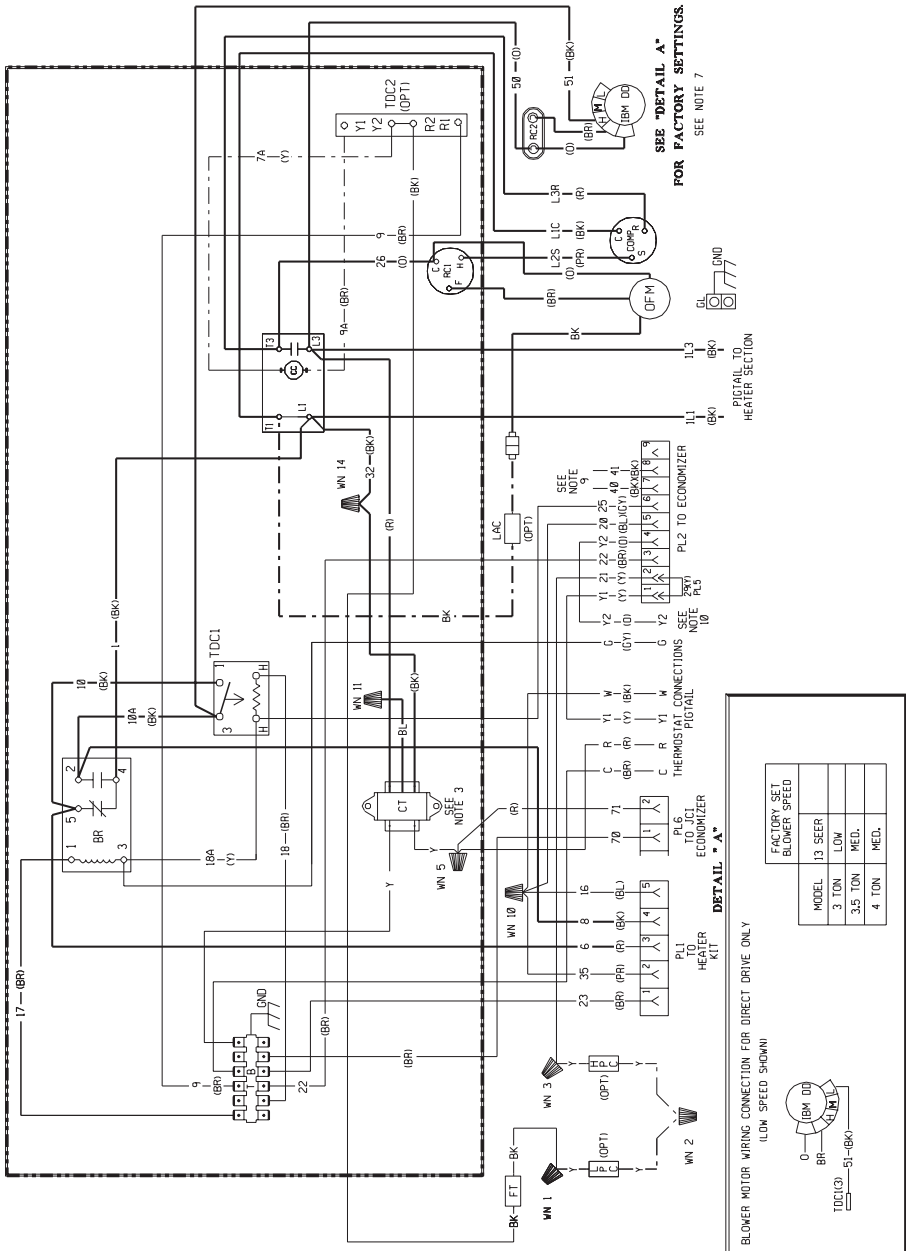

FACTORY SET BLOWER SPEED

MODEL	3 TON	3.5 TON	4 TON
LOW			
MED.			
HIGH			

WIRE COLOR CODE

- BK...BLACK
- BR...BROWN
- BL...BLUE
- G...GREEN
- GY...GRAY
- O...ORANGE
- PK...PINK
- PR...PURPLE
- R...RED
- W...WHITE
- Y...YELLOW

WIRING INFORMATION

- LINE VOLTAGE
- FACTORY STANDARD
- FACTORY OPTION
- FIELD INSTALLED
- LOW VOLTAGE
- FACTORY STANDARD
- FACTORY OPTION
- FIELD INSTALLED
- REPLACEMENT WIRE
- MUST BE THE SAME SIZE AND TYPE OF INSULATION AS ORIGINAL (105 C\*MIN.)
- WARNING
- CABINET MUST BE PERMANENTLY GROUNDED AND CONFORM TO I.E.C., N.E.C., C.E.C. AND LOCAL CODES AS APPLICABLE.

NOTES:

1. CONNECTORS SUITABLE FOR USE WITH COPPER CONDUCTORS, ONLY.
2. COMPRESSOR MOTOR THERMALLY PROTECTED, ALL 3 PHASE MODELS ARE PROTECTED UNDER SINGLE PHASE CONDITIONS.
3. CONTROL TRANSFORMER PRIMARY LEADS: RED-COM, BLUE-280V, W, Y & C MODELS; INTERCHANGE BLACK & BLUE LEADS FOR 208 VOLT OPERATION.
4. CONTACTOR FACTORY WIRED. CONNECT FIELD WIRE TO FACTORY LOW VOLTAGE CIRCUIT IS N.E.C. CLASS 2 WITH A CLASS 2 TRANSFORMER, 24V/50/60 HZ SUPPLIED.
5. CONNECT FUSE WIRING IN GROUNDING RAIN TIGHT CONDUIT TO 60 HZ.
6. CONNECT FUSE WIRING IN GROUNDING RAIN TIGHT CONDUIT TO 60 HZ.
7. SEE FUSE LABEL ON UNIT FUSE BOX FOR FUSE SIZING AND CLASSIFICATION (17 & 8) TO THE MIXED AIR SENSOR ON THE OPTIONAL ECONOMIZER.
8. SEE FUSE LABEL ON UNIT FUSE BOX FOR FUSE SIZING AND CLASSIFICATION (17 & 8) TO THE MIXED AIR SENSOR ON THE OPTIONAL ECONOMIZER.
9. OPTIONAL ECONOMIZER.
10. Y2 IS USED ONLY FOR THE OPTIONAL ECONOMIZER.

COMPONENT CODE

- BR BLOWER RELAY
- CC COMPRESSOR CONTACTOR
- CC/MP CONTROL TRANSFORMER
- CT CONTROL TRANSFORMER
- FT FREEZE STAT
- DL GROUND LUG
- DL GROUND
- HP/HS HIGH PRESSURE CONTROL
- ID/SD INDUCED DRAFT MOTOR DIRECT DRIVE
- LAC LOW AMBIENT COOLING CONTROL
- LPC LOW PRESSURE CONTROL
- OFM OUTDOOR FAN MOTOR
- PL/C PLUG CAPACITOR
- PC TERMINAL BLOCK (LOW VOLTAGE)
- TDC TIME DELAY CONTROL
- WN WIRE NUT

ELECTRICAL WIRING DIAGRAM  
208 / 230V, 1 PHASE  
DIRECT DRIVE  
PACKAGE AIR CONDITIONER



**BEFORE PURCHASING THIS APPLIANCE, READ IMPORTANT ENERGY COST AND EFFICIENCY INFORMATION AVAILABLE FROM YOUR RETAILER.**

## **GENERAL TERMS OF LIMITED WARRANTY**

Rheem will furnish a replacement for any part of this product which fails in normal use and service within the applicable periods stated, in accordance with the terms of the limited warranty.

**For Complete Details of the Limited Warranty, Including Applicable Terms and Conditions, See Your Local Installer or Contact the Manufacturer for a Copy.**

Electric Heating Elements for Optional Electric Heating Kits .....	Five (5) Years
Compressor	
14 SEER, 1-Phase, Residential Applications .....	Ten (10) Years
13 SEER Models .....	Five (5) Years
14 SEER Models, 1 Phase/3-Phase, Commercial Applications.....	Five (5) Years
Any Other Part	
1-Phase Models (Residential Applications) ..	Five (5) Years
3-Phase Models (Commercial Applications)...	One (1) Year

**Before proceeding with installation, refer to installation instructions packaged with each model, as well as complying with all Federal, State, Provincial, and Local codes, regulations, and practices.**

**Rheem Heating,  
Cooling and  
Water Heating**

P.O. Box 17010, Fort Smith, AR 72917



*"In keeping with its policy of continuous progress and product improvement, Rheem reserves the right to make changes without notice."*