

SUBMITTAL COVER SHEET

PROJECT NAME _____
 LOCATION _____
 ARCHITECT _____
 ENGINEER _____
 CONTRACTOR _____
 SUBMITTED BY _____ DATE _____

UNIT SUMMARY

Quantity						
Unit Designation						
Model No.						
Total Cooling						
Sensible Cooling						
Air Ent. Evaporator						
Air Lvg. Evaporator						
Heating Input						
Heating Output						
CFM/ESP						
EER/SEER						
Electrical						
Minimum Ampacity						
Min.-Max. Breaker						
Net Unit Weight						
Accessory						
Catalog Form Number						

ACCESSORIES:

NOTES:

SUBMITTAL SHEET FOR RQPW-B PACKAGE DUAL FUEL UNITS FEATURING EARTH-FRIENDLY R-410A REFRIGERANT



Nominal Sizes 2 Thru 4 Tons [7.0 thru 14.0 kW]

JOB NAME _____ DATE _____

CONTRACTOR _____ UNIT DESIGNATION _____

ENGINEER _____ MODEL NO. _____

SUBMITTED FOR APPROVAL RECORD LOCATION _____

SUBMITTED BY _____ ORDER NO. _____

UNIT DATA

COOLING PERFORMANCE

TOTAL CAPACITY* MBH
 SENSIBLE CAPACITY* MBH
 OUTDOOR DESIGN TEMP. °F [°C] DB/WB
 TOTAL SUPPLY AIR CFM [L/s]
 TEMP. OF AIR ENTERING
 EVAPORATOR COIL..... °F [°C] DB/WB
 POWER INPUT REQUIREMENT KW
 SEER RATING.....
 (*uses blower motor heat)

HEATING PERFORMANCE

GAS HEAT INPUT CAPACITY..... MBH
 GAS HEAT OUTPUT CAPACITY..... MBH
 STEADY STATE EFF MBH
 AFUE C.O.P.
 HEAT PUMP HEATING PERFORMANCE
 CAPACITY @ 47°F MBH
 CAPACITY @ 17°F MBH
 COEFFICIENT OF PERFORMANCE
 @ 47°F..... C.O.P.
 @ 17°F..... C.O.P.
 ELECTRIC HEAT CAPACITY KW
 H.S.P.F.

SUPPLY AIR BLOWER PERFORMANCE

TOTAL SUPPLY AIR CFM [L/s]
 TOTAL RESISTANCE EXTERNAL
 TO UNIT..... IWG
 BLOWER SPEED RPM
 POWER OUTPUT REQUIREMENT .. BHP
 MOTOR RATING HP [W]
 POWER INPUT REQUIREMENT KW

ELECTRICAL DATA

POWER SUPPLY / / /
 TOTAL UNIT AMPACITY..... AMPS
 MINIMUM WIRE SIZE AWG
 MAXIMUM OVERCURRENT DEVICE
 FUSES HACR BREAKER AMPS

TOTAL UNIT WEIGHT

TOTAL OPERATING WEIGHT LBS [kg]
 (including field-installed accessories)

CLEARANCES

SIDE "A" (WITHOUT ECONOMIZER) 2" [50.8 mm]
 SIDE "B" (WITHOUT ECONOMIZER) 12" [304.8 mm]
 SIDE "C" (WITHOUT ECONOMIZER) 48" [1,219.2 mm]
 SIDE "D" (WITHOUT ECONOMIZER) 24" [610 mm]
 ABOVE UNIT (WITHOUT ECONOMIZER) 60" [1,524 mm]

TOP VIEW

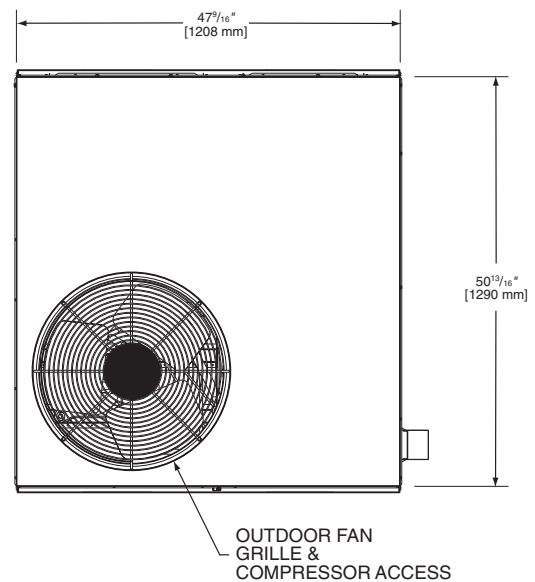

BOTTOM VIEW

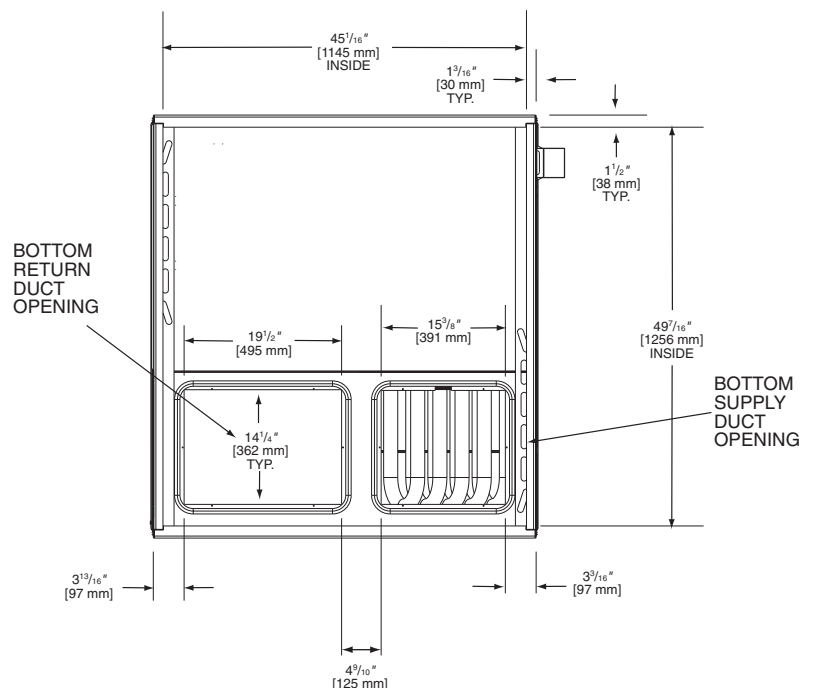

[] Designates Metric Conversions

FIELD INSTALLED ACCESSORIES

- Roof Curb (14" [356 mm] & 24" [610 mm] Sloped Platform)
- Filter Kit
- Lift Kit (For Rigging)
- Low Ambient Control
- Economizer (Downflow Only)
- Economizer (Sideflow Only)

- Fresh Air Damper
- L.P. (Conversion) Kit
- Transition Rectangular-Round (Downflow)
- Concentric Diffuser and Grille
- High Pressure Control
- Thermostat with Outdoor Sensor.....

FRONT VIEW

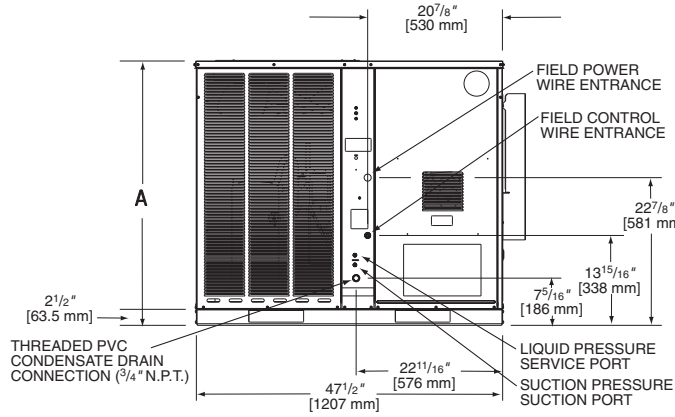

BACK VIEW

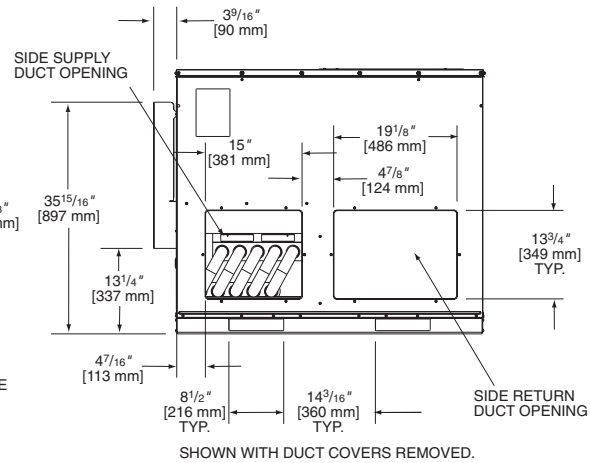

Model #	"A" Height
B024	3515/16"
B030, B036 B042, B048	41"

SIDE VIEW

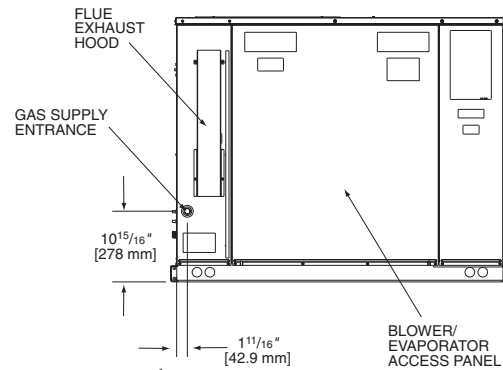

SIDE VIEW

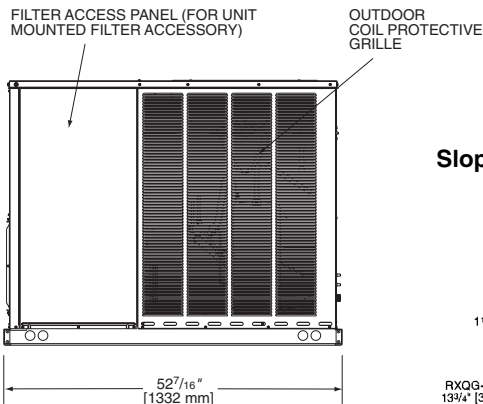

Sloped Curb

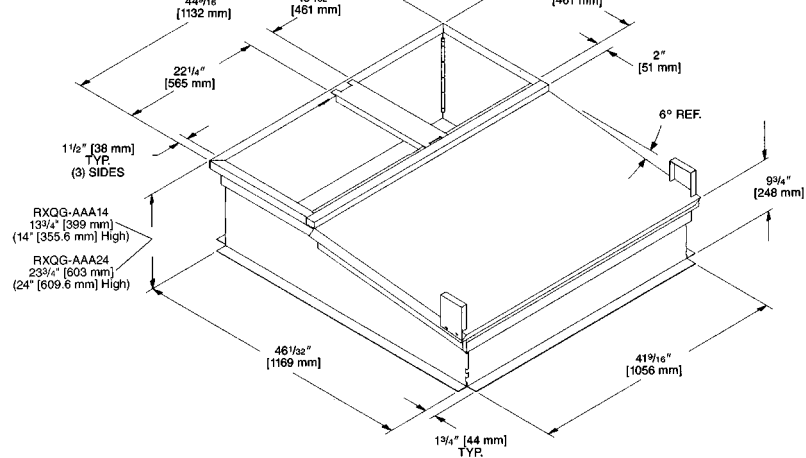

[] Designates Metric Conversions

Before proceeding with installation, refer to installation instructions packaged with each model, as well as complying with all Federal, State, Provincial, and Local codes, regulations, and practices.

RHEEM
MANUFACTURING
COMPANY
5600 Old Greenwood Road, Fort Smith, Arkansas 72908

"In keeping with its policy of continuous progress and product improvement, Rheem reserves the right to make changes without notice."