



PACKAGE AIR CONDITIONING UNITS

FORM NO. S22-938 REV. 2
Supersedes Form No. S22-938 Rev. 1

Featuring Industry Standard R-410A Refrigerant

R-410A

RLNL-C HIGH EFFICIENCY SERIES With ClearControl™ (DDC) NOMINAL SIZES 6-12.5 TONS [21.1-44.0 kW] ASHRAE 90.1-2010 COMPLIANT MODELS



*"Proper sizing and installation of equipment is critical to achieve optimal performance.
Ask your Contractor for details or visit www.energystar.gov."*



Unit Features & Benefits3-8

Selection Procedure9

Model Identification Options10-11

General Data

 RLNL-C Series.....12-20

Performance Data

 RLNL-C Series.....21-23

Airflow Performance

 RLNL-C Series.....24-28

Electrical Data

 RLNL-C Series.....29-32

Units with Heater Kits.....33-38

Dimensional Data39-42

Accessories43-65

Mechanical Specifications66-71

Typical Wiring72-75

Limited Warranty76

These quality features are included in the Ruud Package Air Conditioner Unit



STANDARD FEATURES INCLUDE:

- R-410A HFC refrigerant.
- Complete factory charged, wired and run tested.
- Scroll compressors with internal line break overload and high-pressure protection.
- Single stage compressor on C072 model.
- Two stage compressor on C090 – C151 model.
- Convertible airflow.
- TXV refrigerant metering system on each circuit (except on C072).
- High Pressure and Low Pressure/Loss of charge protection standard on all models.
- Solid Core liquid line filter drier on each circuit.
- Single slab, single pass designed evaporator and condenser coils facilitate easy cleaning for maintained high efficiencies.
- Cooling operation up to 125 degree F ambient.
- Foil faced insulation encapsulated throughout entire unit minimizes airborne fibers from the air stream.
- Hinged major access door with heavy-duty gasketing, 1/4 turn latches and door retainers.
- Slide Out Indoor fan assembly for added service convenience.
- Powder Paint Finish meets ASTM B117 steel coated on each side for maximum protection. G90 galvanized.
- One piece top cover and one piece base pan with drawn supply and return opening for superior water management.
- Forkable base rails for easy handling and lifting.
- Single point electrical connections.
- Internally sloped slide out condensate pan conforms to ASHRAE 62 standards.
- High performance belt drive motor with variable pitch pulleys and quick adjust belt system.
- Permanently lubricated evaporator, condenser and gas heat inducer motors.
- Condenser motors are internally protected, totally enclosed with shaft down design.
- 2 inch filter standard with slide out design.
- 24 volt control system with resettable circuit breakers.
- Colored and labeled wiring.
- Copper tube/Aluminum Fin coils (12¹/₂ ton uses MicroChannel condenser).
- Molded compressor plug.
- Supplemental electric heat provides 100% efficient heating.
- Factory Installed Direct Digital Control (DDC) and sensors which can connect to LonWorks™ or BACnet® BAS systems for remote monitoring and control.

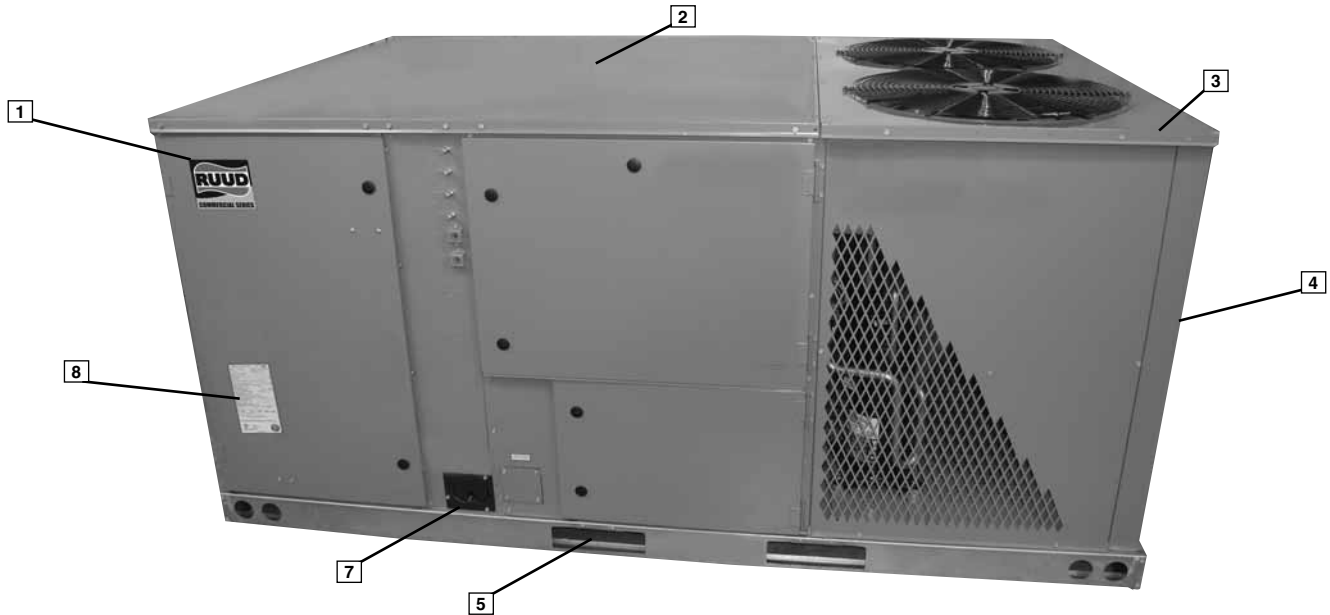

Ruud Package equipment is designed from the ground up with the latest features and benefits required to compete in today's market. The clean design stands alone in the industry and is a testament to the quality, reliability, ease of installation and serviceability that goes into each unit. Outwardly, the large Ruud *Commercial Series*[™] label (1) identifies the brand to the customer. The sheet-metal cabinet (2) uses nothing less than 18-gauge material for structural components with an underlying coat of G90. To ensure the leak-proof integrity of these units, the design utilizes a one-piece top with a 1/8" drip lip (3), gasket-protected panels and screws. The Ruud hail guard (optional) (4) is its trademark, and sets the standard for coil protection in the industry. Every Ruud package unit uses the toughest finish in the industry, using electro deposition baked-on enamel tested to withstand a rigorous 1000-hour salt spray test, per ASTM B117.

Anything built to last must start with the right foundation. In this case, the foundation is 14-gauge, commercial-grade, full-perimeter base rails (5), which integrate fork slots and rigging holes to save set-up time on the job site. The base pan is stamped, which forms a 1-1/8" flange around the supply and return cover and has eliminated the worry of water entering the conditioned space (6). The insulation has been placed on the underside of the basepan, removing areas that would allow for potential moisture accumulation, which can facilitate growth of harmful bacteria. All insulation is secured with both adhesive and mechanical fasteners, and all edges are hidden. The drainpan (7) is made of material that resists the growth of harmful bacteria and is sloped for the latest IAQ benefits. Furthermore, the drainpan slides out for easy cleaning.

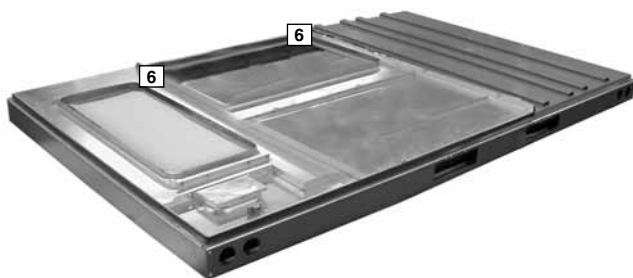

During development, each unit was tested to U.L. 1995, AHRI 340-370 and other Ruud-required reliability tests. Ruud adheres to stringent ISO 9002 quality procedures, and each unit bears the U.L. and AHRI certification labels located on the unit nameplate (8). Contractors can rest assured that when a Ruud package unit arrives at the job, it is ready to go with a factory charge and quality checks.

Access to all major compartments is from the front of the unit, including the filter and electrical compartment, blower compartment, heating section, and outdoor section. Each compartment has 1/4 turn fasteners and hinged access. Each panel is permanently embossed with the compartment name (control/filter access, blower access and electric heat access).

Electrical and filter compartment access is through a large, hinged-access panel. On the outside of the panel is the unit nameplate, which contains the model and serial number, electrical data and other important unit information.

The unit charging chart is located on the inside of the electrical and filter compartment door. Electrical wiring diagrams are found on the control box cover, which allows contractors to move them to more readable locations. To the right of the control box the model and serial number can be found. Having this information on the inside will assure model identification for the life of the product. The production line quality test assurance label is also placed in this location (9). The two-inch throwaway filters (10) are easily removed on a tracked system for easy replacement.

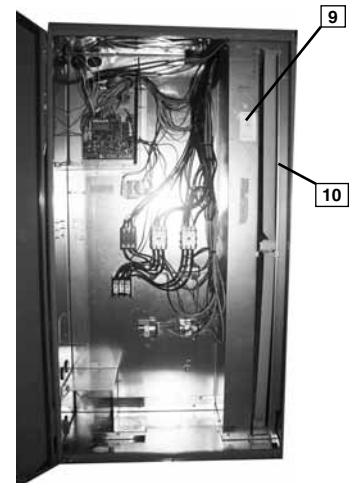

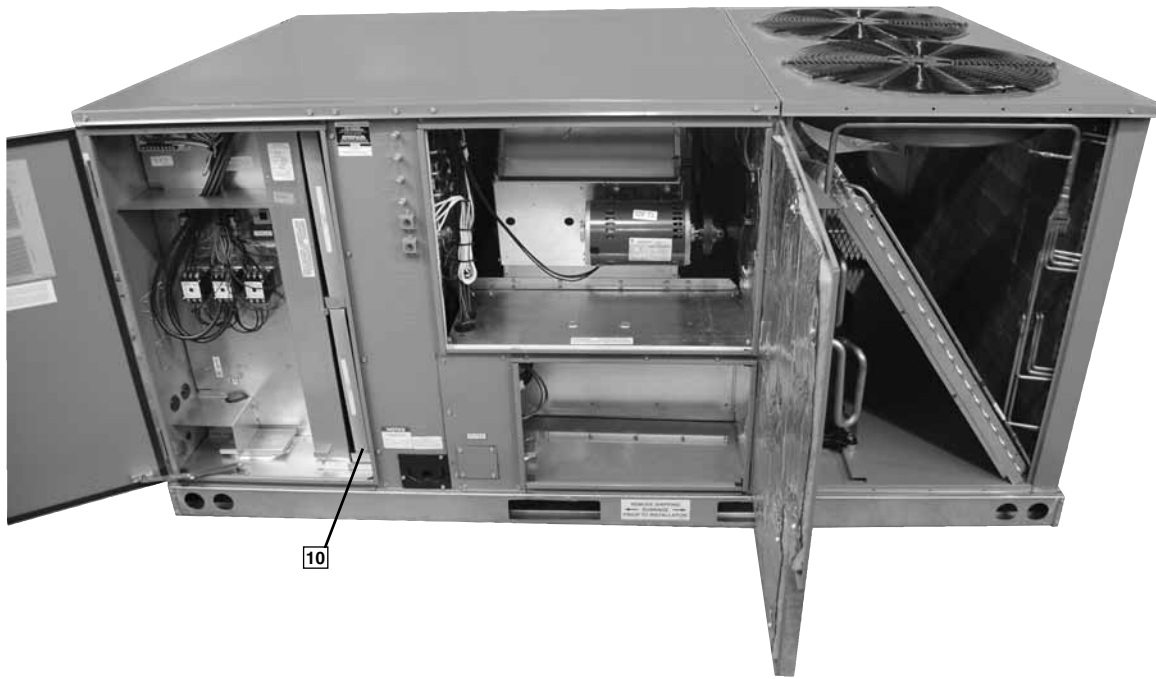

Inside the control box (11), each electrical component is clearly identified with a label that matches the component to the wire diagram for ease of trouble shooting. All wiring is numbered on each end of the termination and color-coded to match the wiring diagram. The control transformer has a low voltage circuit breaker that trips if a low voltage electrical short occurs. There is a blower contactor and compressor for each compressor.

As part of the ClearControl™ system which allows real time monitoring and communication between rooftop units, the RLNL-C Package Heat Pump has a Rooftop Unit Controller (RTU-C) factory mounted and wired in the control panel. The RTU-C is a solid-state microprocessor-based control board that provides flexible control and extensive diagnostics for all unit functions. The RTU-C through proportional/integral control algorithms perform specific unit functions that govern unit operation in response to: zone conditions, system temperatures, system pressures, ambient conditions and electrical inputs. The RTU-C features a 16 x 2 character LCD display and a five-button keypad for local configuration and direct diagnosis of the system. (12) New features include a clogged filter switch (CFS), fan proving switch (FPS), return air temperature sensor (RAT), discharge air temperature sensor (DAT) and outdoor air temperature sensor (OAT). Freeze sensors (FS) are used in place of freezestats to allow measurement of refrigerant suction line temperatures. The RLNL-C Package Air Conditioner with ClearControl™ is specifically designed to be applied in four distinct applications:

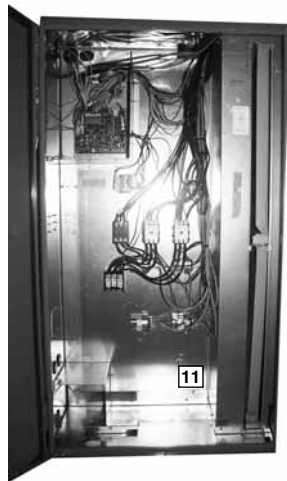

The RLNL-C is compatible with a third party building management system that supports the BACnet Application Specific Controller device profile, with the use of a field installed BACnet Communication Module. The BACnet Communication Module plugs onto the unit RTU-C controller and allows communication between ClearControl™ and the BACnet MSTP network. A zone sensor, a BACnet network zone sensor, a BACnet thermostat or DDC controller may be used to send the zone temperature or thermostat demands to the RTU-C. The BACnet Communication Module is compatible with MSTP EIA-485 daisy chain networks communicating at 38.4 bps. It is compatible with twisted pair, shielded cables.

The RLNL-C is compatible with a third party building management system that supports the LonMark Space Comfort Controller (SCC) functional profile or LonMark Discharge Air Controller (DAC) functional profile. This is accomplished with a field installed LonMark communication module. The LonMark Communication Module plugs onto the RTU-C controller and allows communication between ClearControl™ and a LonWorks Network. A zone sensor, a LonTalk network zone sensor, or a LonTalk thermostat or DDC controller may be used to send the zone temperature or thermostat demands to the RTU-C. The LonMark Communication Module utilizes an FTT-10A free topology transceiver communicating at 78.8 kbps. It is compatible with Echelon qualified twisted pair cable, Belden 8471 or NEMA Level 4 cables. The Module can communicate up to 1640 ft. with no repeater. The LonWorks limit of 64 nodes per segment applies to this device.

The RLNL-C is compatible with a programmable 24 volt thermostat. Connections are made via conventional thermostat screw terminals. Extensive unit status and diagnostics are displayed on the LCD screen of the RTU-C.

The RLNL-C is compatible with a zone sensor and mechanical or solid state time clock connected to the RTU-C. Extensive unit status and diagnostics are displayed on the LCD screen of the RTU-C.

A factory or field installed Comfort Alert® module is available for power phase-monitoring protection and additional compressor diagnostics. The alarms can be displayed on the RTU-C display, through the (BAS) network, or connected to the “L-Terminal” of a thermostat for notification.

For added convenience in the field, a factory-installed convenience outlet (13) is available. Low and High voltage can enter either from the side or through the base. Low-voltage connections are made integrated cooling control. The high-voltage connection is terminated at the number 1 compressor contactor. The suggested mounting for the field-installed disconnect is on the exterior side of the electrical control box.



To the right of the electrical and filter compartment are the externally mounted gauge ports, which are permanently identified by embossed wording that clearly identifies the compressor circuit, high pressure connection and low pressure connection (14). With the gauge ports mounted externally, an accurate diagnostic of system operation can be performed quickly and easily.



The blower compartment is to the right of the gauge ports and can be accessed by 1/4 turn fasteners. To allow easy maintenance of the blower assembly, the entire assembly easily slides out by removing the 3/8" screws from the blower retention bracket. The adjustable motor pulley (15) can easily be adjusted by loosening the bolts on either side of the motor mount. Removing the bolts allows for easy removal of the blower pulley by pushing the blower assembly up to loosen the belt. Once the pulley is

removed, the motor sheave can be adjusted to the desired number of turns, ranging from 0 to 6 turns open. Where the demands for the job require high static, Ruud has high-static drives available that deliver nominal airflow up to 2" of static. By referring to the airflow performance tables listed in the installation instructions, proper static pressure and CFM requirements can be dialed in. The scroll housing (16) and blower scroll provide quiet and efficient airflow. The blower sheave is secured by an "H" bushing which firmly secures the pulley to the blower shaft for years of trouble-free operation. The "H" bushing allows for easy removal of the blower pulley from the shaft, as opposed to the use of a set screw, which can score the shaft, creating burrs that make blower-pulley removal difficult.

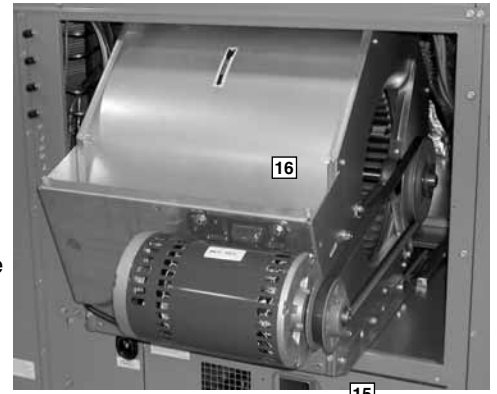

Also inside the blower compartment is the low-ambient control (17), low-pressure switch (18), high-pressure switch (19) and freeze sensor refrigerant safety device (20). The low-ambient control allows for operation of the compressor down to 0 degrees ambient temperature by cycling the outdoor fans on high pressure. The high-pressure switch will shut off the compressors if pressures in excess of 610 PSIG are detected, this may occur if the outdoor fan motor fails. The low-pressure switch shuts off the compressors if low pressure is detected due to loss of charge. The freeze sensor protects the compressor if the evaporator coil gets too cold (below freezing) due to low airflow, and allows monitoring of the suction line temperature on the controller display. Each factory-installed option is brazed into the appropriate high or low side and wired appropriately. Use of polarized plugs and schrader fittings allow for easy field installation.

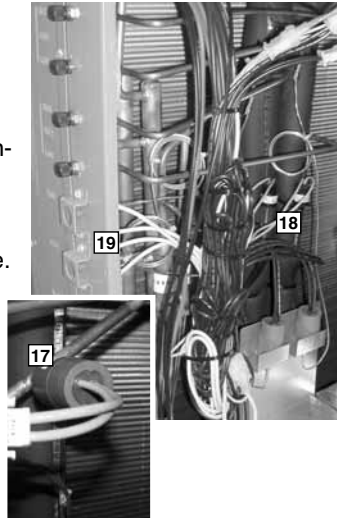

Inside the blower compartment the interlaced evaporator can also be viewed. The evaporator uses enhanced fin technology for maximum heat transfer. The TXV metering device assures even distribution of refrigerant throughout the evaporator. (Note: 6 ton single stage has an orifice refrigerant control.)

Wiring throughout the unit is neatly bundled and routed. Where wire harnesses go through the condenser bulkhead or blower deck, a molded wire harness assembly (20) provides an air-tight and water-tight seal, and provides strain relief. Care is also taken to tuck raw edges of insulation behind sheet metal to improve indoor air quality.

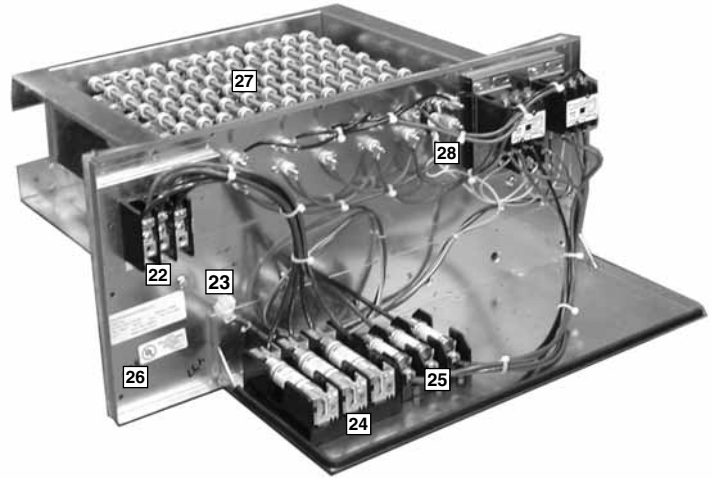
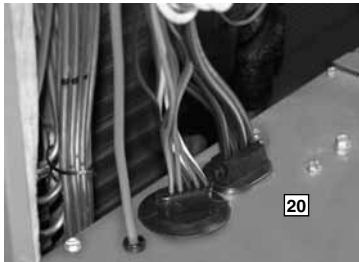

The heating compartment contains the latest electric furnace technology on the market. The 100% efficient electric furnace can be factory-installed or easily field-installed. Built with ease-of-installation in mind, the electric furnace is completely wired for slide-in, plug-and-play installation in the field. With choices of up to six kilowatt offerings, the contractor is assured to get the correct amount of heating output to meet the designed heating load.

Power hook-up in the field is easy with single-point wiring to a terminal block (22) and a polarized plug for the low-voltage connection (23). The electric furnace comes with fuses for the unit (24) and for the electric furnace (25), and is UL certified (26). The electric heating elements are of a wound-wire construction (27) and isolated with ceramic bushings. The limit switch (28) protects the design from over-temperature conditions. Each electric furnace has the capability to be converted from single-stage operation to two-stage operation by removing a jumper on the low-voltage terminal strip.

The compressor compartment houses the heart-beat of the unit. The scroll compressor (29) is known for its long life, and for reliable, quiet, and efficient operation. Each compressor has molded compressor plug eliminating potential for mis wiring. The suction and discharge lines are designed with shock loops (30) to absorb the strain and stress that the starting torque, steady state operation, and shut down cycle impose on the refrigerant tubing. Each compressor and circuit is independent for built-in redundancy, and each circuit is clearly marked throughout the system. Each unit has two stages of efficient cooling operation, first stage is approximately 50% of second stage (072 single stage).

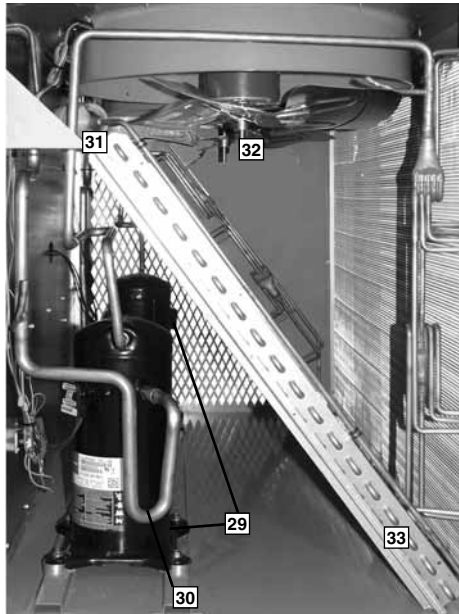

Each unit comes standard with filter dryer (31). The condenser fan motor (32) can easily be accessed and maintained through the compressor compartment. The polarized plug connection allows the motor to be changed quickly and eliminates the need to snake wires through the unit.

The outdoor coil uses the latest enhanced fin design (33) for the most effective method of heat transfer. The outdoor coil is protected by optional louvered panels, which allow unobstructed airflow while protecting the unit from both Mother Nature and vandalism.

Each unit is designed for both downflow or horizontal applications (34) for job configuration flexibility. The return air compartment can also contain an economizer (35).



Three models exist, two for downflow applications, and one for horizontal applications (A downflow economizer with factory installed smoke detector in the return section is available). Each unit is pre-wired for the economizer to allow quick plug-in installation. The economizer is also available as a factory-installed option.

The economizer, which provides free cooling when outdoor conditions are suitable and also provides fresh air to meet local requirements, comes standard with single enthalpy controls. The controls can be upgraded to dual enthalpy easily in the field. The direct drive actuator combined with gear drive dampers has eliminated the need for linkage adjustment in the field. The economizer control has a minimum position setpoint, an outdoor-air setpoint, a mix-air setpoint, and a CO₂ setpoint. Barometric relief is standard on all economizers.

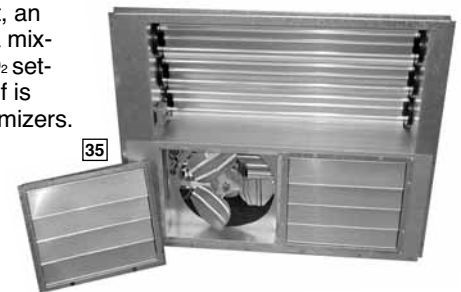

Power Exhaust is easily field-installed.

The power exhaust is housed in the barometric relief opening and is easily slipped in with a plug-in assembly. The wire harness to the economizer also has accommodations for a smoke detector.

The damper minimum position, actual damper position, power exhaust on/off setpoint, mixed air temperature limit setpoint and Demand Controlled Ventilation (DCV) setpoint can be read and adjusted at the unit controller display or remotely through a network connection.

The Space CO₂ level, mixed air temperature, and Economizer Status (Free Cooling Available, Single or Dual Enthalpy) can be read at the unit controller display or remotely through a network connection. Economizer Faults will trigger a network Alarm and can be read at the unit controller display or remotely through a network connection.

The Ruud roofcurb (36) is made for toolless assembly at the jobsite by engaging a pin into the hinged corners of adjacent curb sides, which makes the assembly process quick and easy.

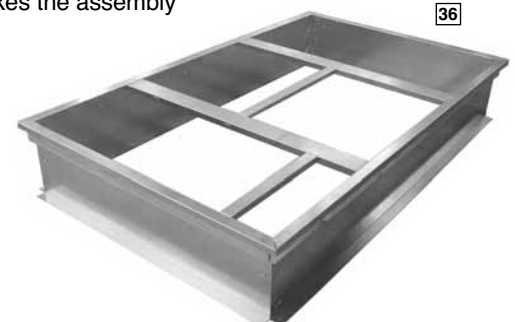



To select an RLNL- Cooling and Heating unit to meet a job requirement, follow this procedure, with example, using data supplied in this specification sheet.

1. DETERMINE COOLING AND HEATING REQUIREMENTS AND SPECIFIC OPERATING CONDITIONS FROM PLANS AND SPECS.

Example:

| | |
|---------------------------------|-----------------------------------|
| Voltage— | 208/240V 3 Phase |
| Total cooling capacity— | 106,000 BTUH [31.26 kW] |
| Sensible cooling capacity— | 82,000 BTUH [24.03 kW] |
| Heating capacity— | 150,000 BTUH [43.96 kW] |
| *Condenser Entering Air— | 95°F [35°C] DB |
| *Evaporator Mixed Air Entering— | 65°F [18°C] WB; 78°F [26°C] DB |
| *Indoor Air Flow (vertical)— | 3600 CFM [1699 L/s] |
| *External Static Pressure— | .40 in. WG |

2. SELECT UNIT TO MEET COOLING REQUIREMENTS.

Since total cooling is within the range of a nominal 10 ton [35.2 kW] unit, enter cooling performance table at 95°F [35°C] DB condenser inlet air. Interpolate between 63°F [2°C] and 67°F [19°C] to determine total and sensible capacity and power input for 65°F [18°C] WB evap inlet air at 4000 CFM [1888 L/s] indoor air flow (table basis):

Total Capacity = 118,900 BTUH [34.80 kW]
 Sensible Capacity = 99,950 BTUH [29.29 kW]
 Power Input (Compressor and Cond. Fans) = 8,950 watts

Use formula $[1.10 \times \text{CFM} \times (1 - \text{DR}) \times (\text{dbE} - 80)]$ in note ① to determine sensible capacity at 80°F [26.7°C] DB evaporator entering air:

Sensible Capacity = 92,268 BTUH [27.24 kW]

3. CORRECT CAPACITIES OF STEP 2 FOR ACTUAL AIR FLOW.

Select factors from airflow correction table at 3600 CFM [1699 L/s] and apply to data obtained in step 2 to obtain gross capacity:

Total Capacity, $118,900 \times .98 = 116,522$ BTUH [34.15 kW]
 Sensible Capacity, $92,268 \times .95 = 87,655$ BTUH [25.67 kW]
 Power Input $11,650 \times .99 = 8,861$ Watts

These are Gross Capacities, not corrected for blower motor heat or power.

4. DETERMINE BLOWER SPEED AND WATTS TO MEET SYSTEM DESIGN.

Enter Indoor Blower performance table at 3600 CFM [1699 L/s]. Total ESP (external static pressure) per the spec of .40 in. includes the system duct and grilles. Add from the table “Component Air Resistance,” .076 for wet coil, .13 for vertical air flow, for a total selection static pressure of .606 (.6) inches of water, and determine:

RPM = 796
 WATTS = 1,650
 DRIVE = L (standard 2 H.P. motor)

5. CALCULATE INDOOR BLOWER BTUH HEAT EFFECT FROM MOTOR WATTS, STEP 4.

$$\text{BTUH} = 1,650 \times 3.412 = 5,630$$

6. CALCULATE NET COOLING CAPACITIES, EQUAL TO GROSS CAPACITY, STEP 3, MINUS INDOOR BLOWER MOTOR HEAT.

$$\text{Net Total Capacity} = 116,522 - 5,630 = 110,892 \text{ BTUH [32.5 kW]}$$

$$\text{Net Sensible Capacity} = 87,655 - 5,630 = 82,025 \text{ BTUH [24.04 kW]}$$

7. CALCULATE UNIT INPUT AND JOB EER.

$$\text{Total Power Input} = 88,610 \text{ (step 3)} + 1,650 \text{ (step 4)} = 10,511 \text{ Watts}$$

$$\text{EER} = \frac{\text{Net Total BTUH [kW]} \text{ (step 6)}}{\text{Power Input, Watts (above)}} = \frac{110,892}{10,511} = 10.55$$

8. SELECT UNIT HEATING CAPACITY.

Units with heater kits section find unit heater kw and convert watts to BTU: add blower BTUH heat effect (step 5).

| CC50C | Heater Kit |
|--------------------|---------------------------|
| kW x 3412 | = 163,776 BTUH [48.00 kW] |
| | + 5,630 BTUH [1.65 kW] |
| Heating Capacity = | 169,406 BTUH [49.65 kW] |

CHOOSE MODEL RLNL-C120CL050

*NOTE: These operating conditions are typical of a commercial application in a 95°F/79°F [35°C/26°C] design area with indoor design of 76°F [24°C] DB and 50% RH and 10% ventilation air, with the unit roof mounted and centered on the zone it conditions by ducts.

[] Designates Metric Conversions

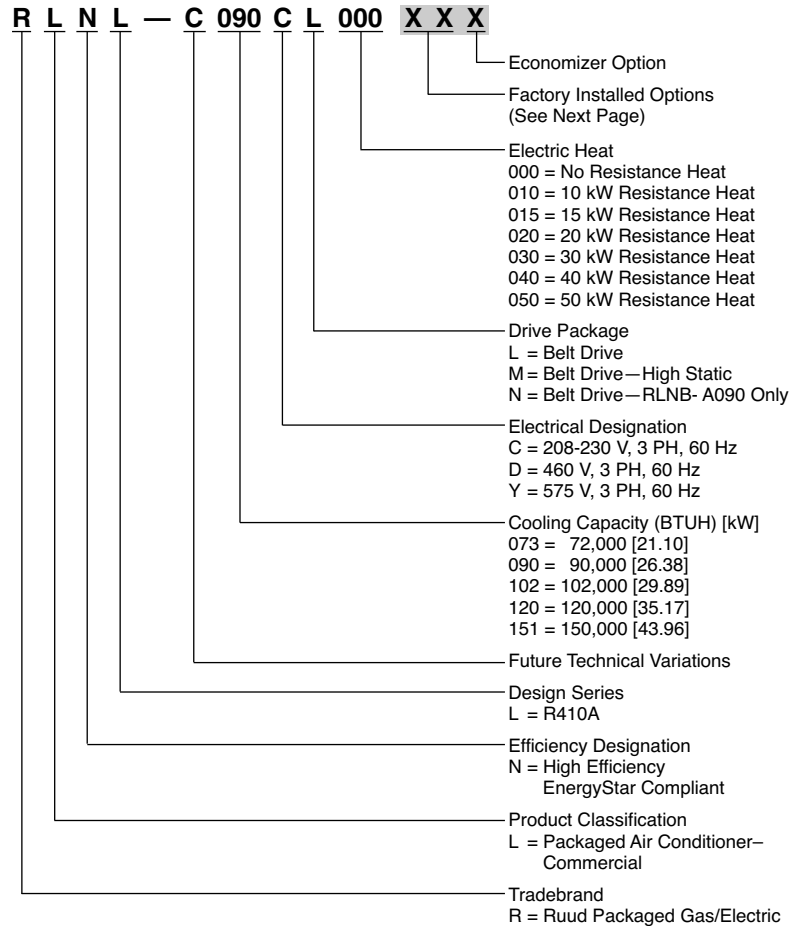

[] Designates Metric Conversions

6 TO 12.5 TON [21.1 TO 44.0 kW]

| Option Code | Hail Guard | Non-Powered Convenience Outlet | Low Ambient/ Comfort Alert | Variable Frequency Drive |
|-------------|------------|--------------------------------|----------------------------|--------------------------|
| AD | X | | | |
| AG | | X | | |
| AR | | | X | |
| AU | | | | X |
| JD | X | | X | |
| BJ | X | X | | |
| CZ | X | X | X | |
| DR | X | X | X | X |
| JE | | X | X | |

"x" indicates factory installed option.

**ECONOMIZER SELECTION FOR LNL
6 TO 12.5 TON [21.1 TO 44.0 kW]**

| | No Economizer | DDC Single Enthalpy Economizer with Barometric Relief | DDC Single Enthalpy Economizer with Barometric Relief and Smoke Detector |
|---|---------------|---|--|
| A | X | | |
| H | | X | |
| J | | | X |

"x" indicates factory installed option.

Instructions for Factory Installed Option(s) Selection

Note: Three characters following the model number will be utilized to designate a factory-installed option or combination of options. If no factory option(s) is required, nothing follows the model number.

Step 1. After a basic rooftop model is selected, choose a *two-character* option code from the FACTORY INSTALLED OPTION SELECTION TABLE.

Proceed to Step 2.

Step 2. The last option code character is utilized for factory-installed economizers. Choose a character from the FACTORY INSTALLED ECONOMIZER SELECTION TABLE.

Examples:

RLNL-C120CL000.....this unit has no factory installed options.

RLNL-C120CL000**ADA**this unit is equipped with *hail guards*.

RLNL-C120CL000**JDA**this unit is equipped with *hail guards, low ambient and comfort alert*.

RLNL-C120CL000**JDH**this unit is equipped as above *and* includes an *Economizer with single enthalpy sensor and with barometric relief*.

RLNL-C120CL000**AAJ**this unit is equipped with an *Economizer with single enthalpy sensor and barometric relief with smoke detector*.

[] Designates Metric Conversions

NOM. SIZES 6-12.5 TONS [21.1-44.0 kW] ASHRAE 90.1-2010 COMPLIANT MODELS

| Model RLNL-C Series | C073CL | C073CM | C073DL | C073DM |
|--|-------------------------|-------------------------|-------------------------|-------------------------|
| Cooling Performance¹ | | | | CONTINUED → |
| Gross Cooling Capacity Btu [kW] | 75,000 [21.97] | 75,000 [21.97] | 75,000 [21.97] | 75,000 [21.97] |
| EER/SEER ² | 11.2/NA | 11.2/NA | 11.2/NA | 11.2/NA |
| Nominal CFM/AHRI Rated CFM [L/s] | 2400/2325 [1133/1097] | 2400/2325 [1133/1097] | 2400/2325 [1133/1097] | 2400/2325 [1133/1097] |
| AHRI Net Cooling Capacity Btu [kW] | 72,000 [21.1] | 72,000 [21.1] | 72,000 [21.1] | 72,000 [21.1] |
| Net Sensible Capacity Btu [kW] | 52,800 [15.47] | 52,800 [15.47] | 52,800 [15.47] | 52,800 [15.47] |
| Net Latent Capacity Btu [kW] | 19,200 [5.63] | 19,200 [5.63] | 19,200 [5.63] | 19,200 [5.63] |
| IEER ³ | 11.8 | 11.8 | 11.8 | 11.8 |
| Net System Power [kW] | 6.42 | 6.42 | 6.42 | 6.42 |
| Compressor | | | | |
| No./Type | 1/Scroll | 1/Scroll | 1/Scroll | 1/Scroll |
| Outdoor Sound Rating (dB)⁴ | 88 | 88 | 88 | 88 |
| Outdoor Coil—Fin Type | Louvered | Louvered | Louvered | Louvered |
| Tube Type | Rifled | Rifled | Rifled | Rifled |
| Tube Size in. [mm] OD | 0.375 [9.5] | 0.375 [9.5] | 0.375 [9.5] | 0.375 [9.5] |
| Face Area sq. ft. [sq. m] | 13.5 [1.25] | 13.5 [1.25] | 13.5 [1.25] | 13.5 [1.25] |
| Rows / FPI [FPcm] | 1 / 22 [9] | 1 / 22 [9] | 1 / 22 [9] | 1 / 22 [9] |
| Indoor Coil—Fin Type | Louvered | Louvered | Louvered | Louvered |
| Tube Type | Rifled | Rifled | Rifled | Rifled |
| Tube Size in. [mm] | 0.375 [9.5] | 0.375 [9.5] | 0.375 [9.5] | 0.375 [9.5] |
| Face Area sq. ft. [sq. m] | 13.5 [1.25] | 13.5 [1.25] | 13.5 [1.25] | 13.5 [1.25] |
| Rows / FPI [FPcm] | 2 / 18 [7] | 2 / 18 [7] | 2 / 18 [7] | 2 / 18 [7] |
| Refrigerant Control | TX Valves | TX Valves | TX Valves | TX Valves |
| Drain Connection No./Size in. [mm] | 1/1 [25.4] | 1/1 [25.4] | 1/1 [25.4] | 1/1 [25.4] |
| Outdoor Fan—Type | Propeller | Propeller | Propeller | Propeller |
| No. Used/Diameter in. [mm] | 2/24 [609.6] | 2/24 [609.6] | 2/24 [609.6] | 2/24 [609.6] |
| Drive Type/No. Speeds | Direct/1 | Direct/1 | Direct/1 | Direct/1 |
| CFM [L/s] | 8000 [3775] | 8000 [3775] | 8000 [3775] | 8000 [3775] |
| No. Motors/HP | 2 at 1/3 HP | 2 at 1/3 HP | 2 at 1/3 HP | 2 at 1/3 HP |
| Motor RPM | 1075 | 1075 | 1075 | 1075 |
| Indoor Fan—Type | FC Centrifugal | FC Centrifugal | FC Centrifugal | FC Centrifugal |
| No. Used/Diameter in. [mm] | 1/11x12 [279x305] | 1/11x12 [279x305] | 1/11x12 [279x305] | 1/11x12 [279x305] |
| Drive Type/No. Speeds | Belt/Variable | Belt/Variable | Belt/Variable | Belt/Variable |
| No. Motors | 1 | 1 | 1 | 1 |
| Motor HP | 1 1/2 | 1 1/2 | 1 1/2 | 1 1/2 |
| Motor RPM | 1725 | 1725 | 1725 | 1725 |
| Motor Frame Size | 56 | 56 | 56 | 56 |
| Filter—Type | Disposable | Disposable | Disposable | Disposable |
| Furnished | Yes | Yes | Yes | Yes |
| (NO.) Size Recommended in. [mm x mm x mm] | (6)2x18x18 [51x457x457] | (6)2x18x18 [51x457x457] | (6)2x18x18 [51x457x457] | (6)2x18x18 [51x457x457] |
| Refrigerant Charge Oz. [g] | 125 [3544] | 125 [3544] | 125 [3544] | 125 [3544] |
| Weights | | | | |
| Net Weight lbs. [kg] | 901 [409] | 901 [409] | 901 [409] | 901 [409] |
| Ship Weight lbs. [kg] | 938 [425] | 938 [425] | 938 [425] | 938 [425] |

NOTES:

1. Cooling Performance is rated at 95° F ambient, 80° F entering dry bulb, 67° F entering wet bulb. Gross capacity does not include the effect of fan motor heat. AHRI capacity is net and includes the effect of fan motor heat. Units are suitable for operation to ±20% of nominal cfm. Units are certified in accordance with the Unitary Air Conditioner Equipment certification program, which is based on AHRI Standard 340/360.
2. EER and/or SEER are rated at AHRI conditions and in accordance with DOE test procedures.
3. Integrated Energy Efficiency Ratio (IEER) is rated in accordance with AHRI Standard 340/360.
4. Outdoor Sound Rating shown is tested in accordance with AHRI Standard 270.

[] Designates Metric Conversions



NOM. SIZES 6-12.5 TONS [21.1-44.0 kW] ASHRAE 90.1-2010 COMPLIANT MODELS

| Model RLNL-C Series | C073YL | C073YM | C090CL | C090CM |
|--|-------------------------|-------------------------|-------------------------|-------------------------|
| Cooling Performance¹ | | | | CONTINUED → |
| Gross Cooling Capacity Btu [kW] | 75,000 [21.97] | 75,000 [21.97] | 93,000 [27.25] | 93,000 [27.25] |
| EER/SEER ² | 11.2/NA | 11.2/NA | 11.2/NA | 11.2/NA |
| Nominal CFM/AHRI Rated CFM [L/s] | 2400/2325 [1133/1097] | 2400/2325 [1133/1097] | 3000/2775 [1416/1310] | 3000/2775 [1416/1310] |
| AHRI Net Cooling Capacity Btu [kW] | 72,000 [21.1] | 72,000 [21.1] | 90,000 [26.37] | 90,000 [26.37] |
| Net Sensible Capacity Btu [kW] | 52,800 [15.47] | 52,800 [15.47] | 63,100 [18.49] | 63,100 [18.49] |
| Net Latent Capacity Btu [kW] | 19,200 [5.63] | 19,200 [5.63] | 26,900 [7.88] | 26,900 [7.88] |
| IEER ³ | 11.8 | 11.8 | 11.9 | 11.9 |
| Net System Power [kW] | 6.42 | 6.42 | 7.99 | 7.99 |
| Compressor | | | | |
| No./Type | 1/Scroll | 1/Scroll | 2/Scroll | 2/Scroll |
| Outdoor Sound Rating (dB)⁴ | 88 | 88 | 88 | 88 |
| Outdoor Coil—Fin Type | Louvered | Louvered | Louvered | Louvered |
| Tube Type | Rifled | Rifled | Rifled | Rifled |
| Tube Size in. [mm] OD | 0.375 [9.5] | 0.375 [9.5] | 0.375 [9.5] | 0.375 [9.5] |
| Face Area sq. ft. [sq. m] | 13.5 [1.25] | 13.5 [1.25] | 27 [2.51] | 27 [2.51] |
| Rows / FPI [FPcm] | 1 / 22 [9] | 1 / 22 [9] | 1 / 22 [9] | 1 / 22 [9] |
| Indoor Coil—Fin Type | Louvered | Louvered | Louvered | Louvered |
| Tube Type | Rifled | Rifled | Rifled | Rifled |
| Tube Size in. [mm] | 0.375 [9.5] | 0.375 [9.5] | 0.375 [9.5] | 0.375 [9.5] |
| Face Area sq. ft. [sq. m] | 13.5 [1.25] | 13.5 [1.25] | 13.5 [1.25] | 13.5 [1.25] |
| Rows / FPI [FPcm] | 2 / 18 [7] | 2 / 18 [7] | 2 / 18 [7] | 2 / 18 [7] |
| Refrigerant Control | TX Valves | TX Valves | TX Valves | TX Valves |
| Drain Connection No./Size in. [mm] | 1/1 [25.4] | 1/1 [25.4] | 1/1 [25.4] | 1/1 [25.4] |
| Outdoor Fan—Type | Propeller | Propeller | Propeller | Propeller |
| No. Used/Diameter in. [mm] | 2/24 [609.6] | 2/24 [609.6] | 2/24 [609.6] | 2/24 [609.6] |
| Drive Type/No. Speeds | Direct/1 | Direct/1 | Direct/1 | Direct/1 |
| CFM [L/s] | 8000 [3775] | 8000 [3775] | 8000 [3775] | 8000 [3775] |
| No. Motors/HP | 2 at 1/3 HP | 2 at 1/3 HP | 2 at 1/3 HP | 2 at 1/3 HP |
| Motor RPM | 1075 | 1075 | 1075 | 1075 |
| Indoor Fan—Type | FC Centrifugal | FC Centrifugal | FC Centrifugal | FC Centrifugal |
| No. Used/Diameter in. [mm] | 1/11x12 [279x305] | 1/11x12 [279x305] | 1/15x15 [381x381] | 1/15x15 [381x381] |
| Drive Type/No. Speeds | Belt/Variable | Belt/Variable | Belt/Variable | Belt/Variable |
| No. Motors | 1 | 1 | 1 | 1 |
| Motor HP | 1 1/2 | 1 1/2 | 2 | 2 |
| Motor RPM | 1725 | 1725 | 1725 | 1725 |
| Motor Frame Size | 56 | 56 | 56 | 56 |
| Filter—Type | Disposable | Disposable | Disposable | Disposable |
| Furnished | Yes | Yes | Yes | Yes |
| (NO.) Size Recommended in. [mm x mm x mm] | (6)2x18x18 [51x457x457] | (6)2x18x18 [51x457x457] | (6)2x18x18 [51x457x457] | (6)2x18x18 [51x457x457] |
| Refrigerant Charge Oz. [g] | 125 [3544] | 125 [3544] | 107.5/110.7 [3048/3138] | 107.5/110.7 [3048/3138] |
| Weights | | | | |
| Net Weight lbs. [kg] | 901 [409] | 901 [409] | 1017 [461] | 1017 [461] |
| Ship Weight lbs. [kg] | 938 [425] | 938 [425] | 1054 [478] | 1054 [478] |

NOTES:

1. Cooling Performance is rated at 95° F ambient, 80° F entering dry bulb, 67° F entering wet bulb. Gross capacity does not include the effect of fan motor heat. AHRI capacity is net and includes the effect of fan motor heat. Units are suitable for operation to ±20% of nominal cfm. Units are certified in accordance with the Unitary Air Conditioner Equipment certification program, which is based on AHRI Standard 340/360.
2. EER and/or SEER are rated at AHRI conditions and in accordance with DOE test procedures.
3. Integrated Energy Efficiency Ratio (IEER) is rated in accordance with AHRI Standard 340/360.
4. Outdoor Sound Rating shown is tested in accordance with AHRI Standard 270.

[] Designates Metric Conversions

NOM. SIZES 6-12.5 TONS [21.1-44.0 kW] ASHRAE 90.1-2010 COMPLIANT MODELS

| Model RLNL-C Series | C090CN | C090DL | C090DM | C090DN |
|--|-------------------------|-------------------------|-------------------------|-------------------------|
| Cooling Performance¹ | | | | |
| Gross Cooling Capacity Btu [kW] | 93,000 [27.25] | 93,000 [27.25] | 93,000 [27.25] | 93,000 [27.25] |
| EER/SEER ² | 11.2/NA | 11.2/NA | 11.2/NA | 11.2/NA |
| Nominal CFM/AHRI Rated CFM [L/s] | 3000/2775 [1416/1310] | 3000/2775 [1416/1310] | 3000/2775 [1416/1310] | 3000/2775 [1416/1310] |
| AHRI Net Cooling Capacity Btu [kW] | 90,000 [26.37] | 90,000 [26.37] | 90,000 [26.37] | 90,000 [26.37] |
| Net Sensible Capacity Btu [kW] | 63,100 [18.49] | 63,100 [18.49] | 63,100 [18.49] | 63,100 [18.49] |
| Net Latent Capacity Btu [kW] | 26,900 [7.88] | 26,900 [7.88] | 26,900 [7.88] | 26,900 [7.88] |
| IEER ³ | 11.9 | 11.9 | 11.9 | 11.9 |
| Net System Power kW | 7.99 | 7.99 | 7.99 | 7.99 |
| Compressor | | | | |
| No./Type | 2/Scroll | 2/Scroll | 2/Scroll | 2/Scroll |
| Outdoor Sound Rating (dB)⁴ | | | | |
| | 88 | 88 | 88 | 88 |
| Outdoor Coil—Fin Type | | | | |
| Tube Type | Louvered | Louvered | Louvered | Louvered |
| Tube Size in. [mm] OD | Rifled | Rifled | Rifled | Rifled |
| Tube Size in. [mm] OD | 0.375 [9.5] | 0.375 [9.5] | 0.375 [9.5] | 0.375 [9.5] |
| Face Area sq. ft. [sq. m] | 27 [2.51] | 27 [2.51] | 27 [2.51] | 27 [2.51] |
| Rows / FPI [FPcm] | 1 / 22 [9] | 1 / 22 [9] | 1 / 22 [9] | 1 / 22 [9] |
| Indoor Coil—Fin Type | | | | |
| Tube Type | Louvered | Louvered | Louvered | Louvered |
| Tube Type | Rifled | Rifled | Rifled | Rifled |
| Tube Size in. [mm] | 0.375 [9.5] | 0.375 [9.5] | 0.375 [9.5] | 0.375 [9.5] |
| Face Area sq. ft. [sq. m] | 13.5 [1.25] | 13.5 [1.25] | 13.5 [1.25] | 13.5 [1.25] |
| Rows / FPI [FPcm] | 2 / 18 [7] | 2 / 18 [7] | 2 / 18 [7] | 2 / 18 [7] |
| Refrigerant Control | TX Valves | TX Valves | TX Valves | TX Valves |
| Drain Connection No./Size in. [mm] | 1/1 [25.4] | 1/1 [25.4] | 1/1 [25.4] | 1/1 [25.4] |
| Outdoor Fan—Type | | | | |
| Type | Propeller | Propeller | Propeller | Propeller |
| No. Used/Diameter in. [mm] | 2/24 [609.6] | 2/24 [609.6] | 2/24 [609.6] | 2/24 [609.6] |
| Drive Type/No. Speeds | Direct/1 | Direct/1 | Direct/1 | Direct/1 |
| CFM [L/s] | 8000 [3775] | 8000 [3775] | 8000 [3775] | 8000 [3775] |
| No. Motors/HP | 2 at 1/3 HP | 2 at 1/3 HP | 2 at 1/3 HP | 2 at 1/3 HP |
| Motor RPM | 1075 | 1075 | 1075 | 1075 |
| Indoor Fan—Type | | | | |
| Type | FC Centrifugal | FC Centrifugal | FC Centrifugal | FC Centrifugal |
| No. Used/Diameter in. [mm] | 1/15x15 [381x381] | 1/15x15 [381x381] | 1/15x15 [381x381] | 1/15x15 [381x381] |
| Drive Type/No. Speeds | Belt/Variable | Belt/Variable | Belt/Variable | Belt/Variable |
| No. Motors | 1 | 1 | 1 | 1 |
| Motor HP | 3 | 2 | 2 | 3 |
| Motor RPM | 1725 | 1725 | 1725 | 1725 |
| Motor Frame Size | 56 | 56 | 56 | 56 |
| Filter—Type | | | | |
| Type | Disposable | Disposable | Disposable | Disposable |
| Furnished | Yes | Yes | Yes | Yes |
| (No.) Size Recommended in. [mm x mm x mm] | (6)2x18x18 [51x457x457] | (6)2x18x18 [51x457x457] | (6)2x18x18 [51x457x457] | (6)2x18x18 [51x457x457] |
| Refrigerant Charge Oz. [g] | | | | |
| | 107.5/110.7 [3048/3138] | 107.5/110.7 [3048/3138] | 107.5/110.7 [3048/3138] | 107.5/110.7 [3048/3138] |
| Weights | | | | |
| Net Weight lbs. [kg] | 1025 [465] | 1017 [461] | 1017 [461] | 1025 [465] |
| Ship Weight lbs. [kg] | 1062 [482] | 1054 [478] | 1054 [478] | 1062 [482] |

NOTES:

1. Cooling Performance is rated at 95° F ambient, 80° F entering dry bulb, 67° F entering wet bulb. Gross capacity does not include the effect of fan motor heat. AHRI capacity is net and includes the effect of fan motor heat. Units are suitable for operation to ±20% of nominal cfm. Units are certified in accordance with the Unitary Air Conditioner Equipment certification program, which is based on AHRI Standard 340/360.
2. EER and/or SEER are rated at AHRI conditions and in accordance with DOE test procedures.
3. Integrated Energy Efficiency Ratio (IEER) is rated in accordance with AHRI Standard 340/360.
4. Outdoor Sound Rating shown is tested in accordance with AHRI Standard 270.

[] Designates Metric Conversions



NOM. SIZES 6-12.5 TONS [21.1-44.0 kW] ASHRAE 90.1-2010 COMPLIANT MODELS

| Model RLNL-C Series | C090YL | C090YM | C090YN | C102CL |
|---|-------------------------|-------------------------|-------------------------|-------------------------|
| Cooling Performance¹ | | | | CONTINUED → |
| Gross Cooling Capacity Btu [kW] | 93,000 [27.25] | 93,000 [27.25] | 93,000 [27.25] | 101,000 [29.59] |
| EER/SEER ² | 11.2/NA | 11.2/NA | 11.2/NA | 11.2/NA |
| Nominal CFM/AHRI Rated CFM [L/s] | 3000/2775 [1416/1310] | 3000/2775 [1416/1310] | 3000/2775 [1416/1310] | 3200/3200 [1510/1510] |
| AHRI Net Cooling Capacity Btu [kW] | 90,000 [26.37] | 90,000 [26.37] | 90,000 [26.37] | 97,000 [28.42] |
| Net Sensible Capacity Btu [kW] | 63,100 [18.49] | 63,100 [18.49] | 63,100 [18.49] | 74,000 [21.68] |
| Net Latent Capacity Btu [kW] | 26,900 [7.88] | 26,900 [7.88] | 26,900 [7.88] | 23,000 [6.74] |
| IEER ³ | 11.9 | 11.9 | 11.9 | 12 |
| Net System Power kW | 7.99 | 7.99 | 7.99 | 8.59 |
| Compressor | | | | |
| No./Type | 2/Scroll | 2/Scroll | 2/Scroll | 2/Scroll |
| Outdoor Sound Rating (dB)⁴ | | | | |
| | 88 | 88 | 88 | 88 |
| Outdoor Coil—Fin Type | | | | |
| Tube Type | Louvered | Louvered | Louvered | Louvered |
| Tube Size in. [mm] OD | Rifled | Rifled | Rifled | Rifled |
| Tube Size in. [mm] OD | 0.375 [9.5] | 0.375 [9.5] | 0.375 [9.5] | 0.375 [9.5] |
| Face Area sq. ft. [sq. m] | 27 [2.51] | 27 [2.51] | 27 [2.51] | 27 [2.51] |
| Rows / FPI [FPcm] | 1 / 22 [9] | 1 / 22 [9] | 1 / 22 [9] | 2 / 18 [7] |
| Indoor Coil—Fin Type | | | | |
| Tube Type | Louvered | Louvered | Louvered | Louvered |
| Tube Type | Rifled | Rifled | Rifled | Rifled |
| Tube Size in. [mm] | 0.375 [9.5] | 0.375 [9.5] | 0.375 [9.5] | 0.375 [9.5] |
| Face Area sq. ft. [sq. m] | 13.5 [1.25] | 13.5 [1.25] | 13.5 [1.25] | 13.5 [1.25] |
| Rows / FPI [FPcm] | 2 / 18 [7] | 2 / 18 [7] | 2 / 18 [7] | 2 / 18 [7] |
| Refrigerant Control | TX Valves | TX Valves | TX Valves | TX Valves |
| Drain Connection No./Size in. [mm] | 1/1 [25.4] | 1/1 [25.4] | 1/1 [25.4] | 1/1 [25.4] |
| Outdoor Fan—Type | | | | |
| Propeller | Propeller | Propeller | Propeller | Propeller |
| No. Used/Diameter in. [mm] | 2/24 [609.6] | 2/24 [609.6] | 2/24 [609.6] | 2/24 [609.6] |
| Drive Type/No. Speeds | Direct/1 | Direct/1 | Direct/1 | Direct/1 |
| CFM [L/s] | 8000 [3775] | 8000 [3775] | 8000 [3775] | 8000 [3775] |
| No. Motors/HP | 2 at 1/3 HP | 2 at 1/3 HP | 2 at 1/3 HP | 2 at 1/3 HP |
| Motor RPM | 1075 | 1075 | 1075 | 1075 |
| Indoor Fan—Type | | | | |
| FC Centrifugal | FC Centrifugal | FC Centrifugal | FC Centrifugal | FC Centrifugal |
| No. Used/Diameter in. [mm] | 1/15x15 [381x381] | 1/15x15 [381x381] | 1/15x15 [381x381] | 1/15x15 [381x381] |
| Drive Type/No. Speeds | Belt/Variable | Belt/Variable | Belt/Variable | Belt/Variable |
| No. Motors | 1 | 1 | 1 | 1 |
| Motor HP | 2 | 2 | 3 | 2 |
| Motor RPM | 1725 | 1725 | 1725 | 1725 |
| Motor Frame Size | 56 | 56 | 56 | 56 |
| Filter—Type | | | | |
| Disposable | Disposable | Disposable | Disposable | Disposable |
| Furnished | Yes | Yes | Yes | Yes |
| (No.) Size Recommended in. [mm x mm x mm] | (6)2x18x18 [51x457x457] | (6)2x18x18 [51x457x457] | (6)2x18x18 [51x457x457] | (6)2x18x18 [51x457x457] |
| Refrigerant Charge Oz. (Sys. 1/Sys. 2) [g] | | | | |
| | 107.5/110.7 [3048/3138] | 107.5/110.7 [3048/3138] | 107.5/110.7 [3048/3138] | 154.4/166.6 [4377/4723] |
| Weights | | | | |
| Net Weight lbs. [kg] | 1017 [461] | 1017 [461] | 1025 [465] | 1059 [480] |
| Ship Weight lcs. [kg] | 1054 [478] | 1054 [478] | 1062 [482] | 1096 [497] |

NOTES:

1. Cooling Performance is rated at 95° F ambient, 80° F entering dry bulb, 67° F entering wet bulb. Gross capacity does not include the effect of fan motor heat. AHRI capacity is net and includes the effect of fan motor heat. Units are suitable for operation to ±20% of nominal cfm. Units are certified in accordance with the Unitary Air Conditioner Equipment certification program, which is based on AHRI Standard 340/360.
2. EER and/or SEER are rated at AHRI conditions and in accordance with DOE test procedures.
3. Integrated Energy Efficiency Ratio (IEER) is rated in accordance with AHRI Standard 340/360.
4. Outdoor Sound Rating shown is tested in accordance with AHRI Standard 270.

[] Designates Metric Conversions

NOM. SIZES 6-12.5 TONS [21.1-44.0 kW] ASHRAE 90.1-2010 COMPLIANT MODELS

| Model RLNL-C Series | C102CM | C102DL | C102DM | C102YL |
|---|-------------------------|-------------------------|-------------------------|-------------------------|
| Cooling Performance¹ | | | | |
| | CONTINUED → | | | |
| Gross Cooling Capacity Btu [kW] | 101,000 [29.59] | 101,000 [29.59] | 101,000 [29.59] | 101,000 [29.59] |
| EER/SEER ² | 11.2/NA | 11.2/NA | 11.2/NA | 11.2/NA |
| Nominal CFM/AHRI Rated CFM [L/s] | 3200/3200 [1510/1510] | 3200/3200 [1510/1510] | 3200/3200 [1510/1510] | 3200/3200 [1510/1510] |
| AHRI Net Cooling Capacity Btu [kW] | 97,000 [28.42] | 97,000 [28.42] | 97,000 [28.42] | 97,000 [28.42] |
| Net Sensible Capacity Btu [kW] | 74,000 [21.68] | 74,000 [21.68] | 74,000 [21.68] | 74,000 [21.68] |
| Net Latent Capacity Btu [kW] | 23,000 [6.74] | 23,000 [6.74] | 23,000 [6.74] | 23,000 [6.74] |
| IEER ³ | 12 | 12 | 12 | 12 |
| Net System Power kW | 8.59 | 8.59 | 8.59 | 8.59 |
| Compressor | | | | |
| No./Type | 2/Scroll | 2/Scroll | 2/Scroll | 2/Scroll |
| Outdoor Sound Rating (dB)⁴ | | | | |
| | 88 | 88 | 88 | 88 |
| Outdoor Coil—Fin Type | | | | |
| Tube Type | Louvered | Louvered | Louvered | Louvered |
| Tube Size in. [mm] OD | Rifled | Rifled | Rifled | Rifled |
| Tube Size in. [mm] OD | 0.375 [9.5] | 0.375 [9.5] | 0.375 [9.5] | 0.375 [9.5] |
| Face Area sq. ft. [sq. m] | 27 [2.51] | 27 [2.51] | 27 [2.51] | 27 [2.51] |
| Rows / FPI [FPcm] | 2 / 18 [7] | 2 / 18 [7] | 2 / 18 [7] | 2 / 18 [7] |
| Indoor Coil—Fin Type | | | | |
| Tube Type | Louvered | Louvered | Louvered | Louvered |
| Tube Type | Rifled | Rifled | Rifled | Rifled |
| Tube Size in. [mm] | 0.375 [9.5] | 0.375 [9.5] | 0.375 [9.5] | 0.375 [9.5] |
| Face Area sq. ft. [sq. m] | 13.5 [1.25] | 13.5 [1.25] | 13.5 [1.25] | 13.5 [1.25] |
| Rows / FPI [FPcm] | 2 / 18 [7] | 2 / 18 [7] | 2 / 18 [7] | 2 / 18 [7] |
| Refrigerant Control | TX Valves | TX Valves | TX Valves | TX Valves |
| Drain Connection No./Size in. [mm] | 1/1 [25.4] | 1/1 [25.4] | 1/1 [25.4] | 1/1 [25.4] |
| Outdoor Fan—Type | | | | |
| Propeller | Propeller | Propeller | Propeller | Propeller |
| No. Used/Diameter in. [mm] | 2/24 [609.6] | 2/24 [609.6] | 2/24 [609.6] | 2/24 [609.6] |
| Drive Type/No. Speeds | Direct/1 | Direct/1 | Direct/1 | Direct/1 |
| CFM [L/s] | 8000 [3775] | 8000 [3775] | 8000 [3775] | 8000 [3775] |
| No. Motors/HP | 2 at 1/3 HP | 2 at 1/3 HP | 2 at 1/3 HP | 2 at 1/3 HP |
| Motor RPM | 1075 | 1075 | 1075 | 1075 |
| Indoor Fan—Type | | | | |
| FC Centrifugal | FC Centrifugal | FC Centrifugal | FC Centrifugal | FC Centrifugal |
| No. Used/Diameter in. [mm] | 1/15x15 [381x381] | 1/15x15 [381x381] | 1/15x15 [381x381] | 1/15x15 [381x381] |
| Drive Type/No. Speeds | Belt/Variable | Belt/Variable | Belt/Variable | Belt/Variable |
| No. Motors | 1 | 1 | 1 | 1 |
| Motor HP | 3 | 2 | 3 | 2 |
| Motor RPM | 1725 | 1725 | 1725 | 1725 |
| Motor Frame Size | 56 | 56 | 56 | 56 |
| Filter—Type | | | | |
| Disposable | Disposable | Disposable | Disposable | Disposable |
| Furnished | Yes | Yes | Yes | Yes |
| (No.) Size Recommended in. [mm x mm x mm] | (6)2x18x18 [51x457x457] | (6)2x18x18 [51x457x457] | (6)2x18x18 [51x457x457] | (6)2x18x18 [51x457x457] |
| Refrigerant Charge Oz. (Sys. 1/Sys. 2) [g] | | | | |
| | 154.4/166.6 [4377/4723] | 154.4/166.6 [4377/4723] | 154.4/166.6 [4377/4723] | 154.4/166.6 [4377/4723] |
| Weights | | | | |
| Net Weight lbs. [kg] | 1067 [484] | 1059 [480] | 1067 [484] | 1059 [480] |
| Ship Weight lbs. [kg] | 1104 [501] | 1096 [497] | 1104 [501] | 1096 [497] |

NOTES:

1. Cooling Performance is rated at 95° F ambient, 80° F entering dry bulb, 67° F entering wet bulb. Gross capacity does not include the effect of fan motor heat. AHRI capacity is net and includes the effect of fan motor heat. Units are suitable for operation to ±20% of nominal cfm. Units are certified in accordance with the Unitary Air Conditioner Equipment certification program, which is based on AHRI Standard 340/360.
2. EER and/or SEER are rated at AHRI conditions and in accordance with DOE test procedures.
3. Integrated Energy Efficiency Ratio (IEER) is rated in accordance with AHRI Standard 340/360.
4. Outdoor Sound Rating shown is tested in accordance with AHRI Standard 270.

[] Designates Metric Conversions



NOM. SIZES 6-12.5 TONS [21.1-44.0 kW] ASHRAE 90.1-2010 COMPLIANT MODELS

| Model RLNL-C Series | C102YM | C120CL | C120CM | C120DL |
|---|-------------------------|-------------------------|-------------------------|-------------------------|
| Cooling Performance¹ | | | | CONTINUED → |
| Gross Cooling Capacity Btu [kW] | 101,000 [29.59] | 123,000 [36.04] | 123,000 [36.04] | 123,000 [36.04] |
| EER/SEER ² | 11.2/NA | 11.2/NA | 11.2/NA | 11.2/NA |
| Nominal CFM/AHRI Rated CFM [L/s] | 3200/3200 [1510/1510] | 4000/3750 [1888/1770] | 4000/3750 [1888/1770] | 4000/3750 [1888/1770] |
| AHRI Net Cooling Capacity Btu [kW] | 97,000 [28.42] | 118,000 [34.57] | 118,000 [34.57] | 118,000 [34.57] |
| Net Sensible Capacity Btu [kW] | 74,000 [21.68] | 88,800 [26.02] | 88,800 [26.02] | 88,800 [26.02] |
| Net Latent Capacity Btu [kW] | 23,000 [6.74] | 29,200 [8.56] | 29,200 [8.56] | 29,200 [8.56] |
| IEER ³ | 12 | 11.9 | 11.9 | 11.9 |
| Net System Power kW | 8.59 | 10.49 | 10.49 | 10.49 |
| Compressor | | | | |
| No./Type | 2/Scroll | 2/Scroll | 2/Scroll | 2/Scroll |
| Outdoor Sound Rating (dB)⁴ | | | | |
| | 88 | 88 | 88 | 88 |
| Outdoor Coil—Fin Type | | | | |
| Tube Type | Louvered | Louvered | Louvered | Louvered |
| Tube Size in. [mm] OD | Rifled | Rifled | Rifled | Rifled |
| Tube Size in. [mm] OD | 0.375 [9.5] | 0.375 [9.5] | 0.375 [9.5] | 0.375 [9.5] |
| Face Area sq. ft. [sq. m] | 27 [2.51] | 27 [2.51] | 27 [2.51] | 27 [2.51] |
| Rows / FPI [FPcm] | 2 / 18 [7] | 2 / 22 [9] | 2 / 22 [9] | 2 / 22 [9] |
| Indoor Coil—Fin Type | | | | |
| Tube Type | Louvered | Louvered | Louvered | Louvered |
| Tube Type | Rifled | Rifled | Rifled | Rifled |
| Tube Size in. [mm] | 0.375 [9.5] | 0.375 [9.5] | 0.375 [9.5] | 0.375 [9.5] |
| Face Area sq. ft. [sq. m] | 13.5 [1.25] | 13.5 [1.25] | 13.5 [1.25] | 13.5 [1.25] |
| Rows / FPI [FPcm] | 2 / 18 [7] | 3 / 18 [7] | 3 / 18 [7] | 3 / 18 [7] |
| Refrigerant Control | TX Valves | TX Valves | TX Valves | TX Valves |
| Drain Connection No./Size in. [mm] | 1/1 [25.4] | 1/1 [25.4] | 1/1 [25.4] | 1/1 [25.4] |
| Outdoor Fan—Type | | | | |
| No. Used/Diameter in. [mm] | Propeller | Propeller | Propeller | Propeller |
| Drive Type/No. Speeds | 2/24 [609.6] | 2/24 [609.6] | 2/24 [609.6] | 2/24 [609.6] |
| CFM [L/s] | Direct/1 | Direct/1 | Direct/1 | Direct/1 |
| No. Motors/HP | 8000 [3775] | 8000 [3775] | 8000 [3775] | 8000 [3775] |
| Motor RPM | 2 at 1/3 HP | 2 at 1/3 HP | 2 at 1/3 HP | 2 at 1/3 HP |
| | 1075 | 1075 | 1075 | 1075 |
| Indoor Fan—Type | | | | |
| No. Used/Diameter in. [mm] | FC Centrifugal | FC Centrifugal | FC Centrifugal | FC Centrifugal |
| Drive Type/No. Speeds | 1/15x15 [381x381] | 1/15x15 [381x381] | 1/15x15 [381x381] | 1/15x15 [381x381] |
| No. Motors | Belt/Variable | Belt/Variable | Belt/Variable | Belt/Variable |
| Motor HP | 1 | 1 | 1 | 1 |
| Motor RPM | 3 | 2 | 3 | 2 |
| Motor Frame Size | 1725 | 1725 | 1725 | 1725 |
| | 56 | 56 | 56 | 56 |
| Filter—Type | | | | |
| Furnished | Disposable | Disposable | Disposable | Disposable |
| (No.) Size Recommended in. [mm x mm x mm] | Yes | Yes | Yes | Yes |
| | (6)2x18x18 [51x457x457] | (6)2x18x18 [51x457x457] | (6)2x18x18 [51x457x457] | (6)2x18x18 [51x457x457] |
| Refrigerant Charge Oz. (Sys. 1/Sys. 2) [g] | | | | |
| | 154.4/166.6 [4377/4723] | 172.8/180.8 [4899/5126] | 172.8/180.8 [4899/5126] | 172.8/180.8 [4899/5126] |
| Weights | | | | |
| Net Weight lbs. [kg] | 1067 [484] | 1112 [504] | 1120 [508] | 1112 [504] |
| Ship Weight lbs. [kg] | 1104 [501] | 1149 [521] | 1157 [525] | 1149 [521] |

NOTES:

1. Cooling Performance is rated at 95° F ambient, 80° F entering dry bulb, 67° F entering wet bulb. Gross capacity does not include the effect of fan motor heat. AHRI capacity is net and includes the effect of fan motor heat. Units are suitable for operation to ±20% of nominal cfm. Units are certified in accordance with the Unitary Air Conditioner Equipment certification program, which is based on AHRI Standard 340/360.
2. EER and/or SEER are rated at AHRI conditions and in accordance with DOE test procedures.
3. Integrated Energy Efficiency Ratio (IEER) is rated in accordance with AHRI Standard 340/360.
4. Outdoor Sound Rating shown is tested in accordance with AHRI Standard 270.

[] Designates Metric Conversions

NOM. SIZES 6-12.5 TONS [21.1-44.0 kW] ASHRAE 90.1-2010 COMPLIANT MODELS

| Model RLNL-C Series | C120DM | C120YL | C120YM | C151CL |
|---|-------------------------|-------------------------|-------------------------|-------------------------|
| Cooling Performance¹ | | | | CONTINUED → |
| Gross Cooling Capacity Btu [kW] | 123,000 [36.04] | 123,000 [36.04] | 123,000 [36.04] | 156,000 [45.71] |
| EER/SEER ² | 11.2/NA | 11.2/NA | 11.2/NA | 11.1/NA |
| Nominal CFM/AHRI Rated CFM [L/s] | 4000/3750 [1888/1770] | 4000/3750 [1888/1770] | 4000/3750 [1888/1770] | 5000/4225 [2360/1994] |
| AHRI Net Cooling Capacity Btu [kW] | 118,000 [34.57] | 118,000 [34.57] | 118,000 [34.57] | 150,000 [43.95] |
| Net Sensible Capacity Btu [kW] | 88,800 [26.02] | 88,800 [26.02] | 88,800 [26.02] | 106,600 [31.23] |
| Net Latent Capacity Btu [kW] | 29,200 [8.56] | 29,200 [8.56] | 29,200 [8.56] | 43,400 [12.72] |
| IEER ³ | 11.9 | 11.9 | 11.9 | 10.8 |
| Net System Power kW | 10.49 | 10.49 | 10.49 | 13.54 |
| Compressor | | | | |
| No./Type | 2/Scroll | 2/Scroll | 2/Scroll | 2/Scroll |
| Outdoor Sound Rating (dB)⁴ | | | | |
| | 88 | 88 | 88 | 88 |
| Outdoor Coil—Fin Type | | | | |
| Tube Type | Louvered | Louvered | Louvered | Louvered |
| Tube Type | Rifled | Rifled | Rifled | MicroChannel |
| Tube Size in. [mm] OD | 0.375 [9.5] | 0.375 [9.5] | 0.375 [9.5] | 1 [25.4] |
| Face Area sq. ft. [sq. m] | 27 [2.51] | 27 [2.51] | 27 [2.51] | 27 [2.51] |
| Rows / FPI [FPcm] | 2 / 22 [9] | 2 / 22 [9] | 2 / 22 [9] | 2 / 23 [9] |
| Indoor Coil—Fin Type | | | | |
| Tube Type | Louvered | Louvered | Louvered | Louvered |
| Tube Type | Rifled | Rifled | Rifled | Rifled |
| Tube Size in. [mm] | 0.375 [9.5] | 0.375 [9.5] | 0.375 [9.5] | 0.375 [9.5] |
| Face Area sq. ft. [sq. m] | 13.5 [1.25] | 13.5 [1.25] | 13.5 [1.25] | 13.5 [1.25] |
| Rows / FPI [FPcm] | 3 / 18 [7] | 3 / 18 [7] | 3 / 18 [7] | 4 / 15 [6] |
| Refrigerant Control | TX Valves | TX Valves | TX Valves | TX Valves |
| Drain Connection No./Size in. [mm] | 1/1 [25.4] | 1/1 [25.4] | 1/1 [25.4] | 1/1 [25.4] |
| Outdoor Fan—Type | | | | |
| Propeller | Propeller | Propeller | Propeller | Propeller |
| No. Used/Diameter in. [mm] | 2/24 [609.6] | 2/24 [609.6] | 2/24 [609.6] | 2/24 [609.6] |
| Drive Type/No. Speeds | Direct/1 | Direct/1 | Direct/1 | Direct/1 |
| CFM [L/s] | 8000 [3775] | 8000 [3775] | 8000 [3775] | 8000 [3775] |
| No. Motors/HP | 2 at 1/3 HP | 2 at 1/3 HP | 2 at 1/3 HP | 2 at 1/2 HP |
| Motor RPM | 1075 | 1075 | 1075 | 1075 |
| Indoor Fan—Type | | | | |
| FC Centrifugal | FC Centrifugal | FC Centrifugal | FC Centrifugal | FC Centrifugal |
| No. Used/Diameter in. [mm] | 1/15x15 [381x381] | 1/15x15 [381x381] | 1/15x15 [381x381] | 1/15x15 [381x381] |
| Drive Type/No. Speeds | Belt/Variable | Belt/Variable | Belt/Variable | Belt/Variable |
| No. Motors | 1 | 1 | 1 | 1 |
| Motor HP | 3 | 2 | 3 | 3 |
| Motor RPM | 1725 | 1725 | 1725 | 1725 |
| Motor Frame Size | 56 | 56 | 56 | 56 |
| Filter—Type | | | | |
| Disposable | Disposable | Disposable | Disposable | Disposable |
| Furnished | Yes | Yes | Yes | Yes |
| (No.) Size Recommended in. [mm x mm x mm] | (6)2x18x18 [51x457x457] | (6)2x18x18 [51x457x457] | (6)2x18x18 [51x457x457] | (6)2x18x18 [51x457x457] |
| Refrigerant Charge Oz. (Sys. 1/Sys. 2) [g] | | | | |
| | 172.8/180.8 [4899/5126] | 172.8/180.8 [4899/5126] | 172.8/180.8 [4899/5126] | 147.2/152 [4173/4309] |
| Weights | | | | |
| Net Weight lbs. [kg] | 1120 [508] | 1112 [504] | 1120 [508] | 1230 [558] |
| Ship Weight lbs. [kg] | 1157 [525] | 1149 [521] | 1157 [525] | 1267 [575] |

NOTES:

1. Cooling Performance is rated at 95° F ambient, 80° F entering dry bulb, 67° F entering wet bulb. Gross capacity does not include the effect of fan motor heat. AHRI capacity is net and includes the effect of fan motor heat. Units are suitable for operation to ±20% of nominal cfm. Units are certified in accordance with the Unitary Air Conditioner Equipment certification program, which is based on AHRI Standard 340/360.
2. EER and/or SEER are rated at AHRI conditions and in accordance with DOE test procedures.
3. Integrated Energy Efficiency Ratio (IEER) is rated in accordance with AHRI Standard 340/360.
4. Outdoor Sound Rating shown is tested in accordance with AHRI Standard 270.

[] Designates Metric Conversions



NOM. SIZES 6-12.5 TONS [21.1-44.0 kW] ASHRAE 90.1-2010 COMPLIANT MODELS

| Model RLNL-C Series | C151CM | C151DL | C151DM | C151YL |
|---|-------------------------|-------------------------|-------------------------|-------------------------|
| Cooling Performance¹ | | | | CONTINUED → |
| Gross Cooling Capacity Btu [kW] | 156,000 [45.71] | 156,000 [45.71] | 156,000 [45.71] | 156,000 [45.71] |
| EER/SEER ² | 11.1/NA | 11.1/NA | 11.1/NA | 11.1/NA |
| Nominal CFM/AHRI Rated CFM [L/s] | 5000/4225 [2360/1994] | 5000/4225 [2360/1994] | 5000/4225 [2360/1994] | 5000/4225 [2360/1994] |
| AHRI Net Cooling Capacity Btu [kW] | 150,000 [43.95] | 150,000 [43.95] | 150,000 [43.95] | 150,000 [43.95] |
| Net Sensible Capacity Btu [kW] | 106,600 [31.23] | 106,600 [31.23] | 106,600 [31.23] | 106,600 [31.23] |
| Net Latent Capacity Btu [kW] | 43,400 [12.72] | 43,400 [12.72] | 43,400 [12.72] | 43,400 [12.72] |
| IEER ³ | 10.8 | 10.8 | 10.8 | 10.8 |
| Net System Power kW | 13.54 | 13.54 | 13.54 | 13.54 |
| Compressor | | | | |
| No./Type | 2/Scroll | 2/Scroll | 2/Scroll | 2/Scroll |
| Outdoor Sound Rating (dB)⁴ | | | | |
| | 88 | 88 | 88 | 88 |
| Outdoor Coil—Fin Type | | | | |
| | Louvered | Louvered | Louvered | Louvered |
| Tube Type | MicroChannel | MicroChannel | MicroChannel | MicroChannel |
| Tube Size in. [mm] OD | 1 [25.4] | 1 [25.4] | 1 [25.4] | 1 [25.4] |
| Face Area sq. ft. [sq. m] | 27 [2.51] | 27 [2.51] | 27 [2.51] | 27 [2.51] |
| Rows / FPI [FPcm] | 2 / 23 [9] | 2 / 23 [9] | 2 / 23 [9] | 2 / 23 [9] |
| Indoor Coil—Fin Type | | | | |
| | Louvered | Louvered | Louvered | Louvered |
| Tube Type | Rifled | Rifled | Rifled | Rifled |
| Tube Size in. [mm] | 0.375 [9.5] | 0.375 [9.5] | 0.375 [9.5] | 0.375 [9.5] |
| Face Area sq. ft. [sq. m] | 13.5 [1.25] | 13.5 [1.25] | 13.5 [1.25] | 13.5 [1.25] |
| Rows / FPI [FPcm] | 4 / 15 [6] | 4 / 15 [6] | 4 / 15 [6] | 4 / 15 [6] |
| Refrigerant Control | TX Valves | TX Valves | TX Valves | TX Valves |
| Drain Connection No./Size in. [mm] | 1/1 [25.4] | 1/1 [25.4] | 1/1 [25.4] | 1/1 [25.4] |
| Outdoor Fan—Type | | | | |
| | Propeller | Propeller | Propeller | Propeller |
| No. Used/Diameter in. [mm] | 2/24 [609.6] | 2/24 [609.6] | 2/24 [609.6] | 2/24 [609.6] |
| Drive Type/No. Speeds | Direct/1 | Direct/1 | Direct/1 | Direct/1 |
| CFM [L/s] | 8000 [3775] | 8000 [3775] | 8000 [3775] | 8000 [3775] |
| No. Motors/HP | 2 at 1/2 HP | 2 at 1/2 HP | 2 at 1/2 HP | 2 at 1/2 HP |
| Motor RPM | 1075 | 1075 | 1075 | 1075 |
| Indoor Fan—Type | | | | |
| | FC Centrifugal | FC Centrifugal | FC Centrifugal | FC Centrifugal |
| No. Used/Diameter in. [mm] | 1/15x15 [381x381] | 1/15x15 [381x381] | 1/15x15 [381x381] | 1/15x15 [381x381] |
| Drive Type/No. Speeds | Belt/Variable | Belt/Variable | Belt/Variable | Belt/Variable |
| No. Motors | 1 | 1 | 1 | 1 |
| Motor HP | 5 | 3 | 5 | 3 |
| Motor RPM | 1725 | 1725 | 1725 | 1725 |
| Motor Frame Size | 184 | 56 | 184 | 56 |
| Filter—Type | | | | |
| | Disposable | Disposable | Disposable | Disposable |
| Furnished | Yes | Yes | Yes | Yes |
| (No.) Size Recommended in. [mm x mm x mm] | (6)2x18x18 [51x457x457] | (6)2x18x18 [51x457x457] | (6)2x18x18 [51x457x457] | (6)2x18x18 [51x457x457] |
| Refrigerant Charge Oz. (Sys. 1/Sys. 2) [g] | | | | |
| | 147.2/152 [4173/4309] | 147.2/152 [4173/4309] | 147.2/152 [4173/4309] | 147.2/152 [4173/4309] |
| Weights | | | | |
| Net Weight lbs. [kg] | 1238 [562] | 1230 [558] | 1238 [562] | 1230 [558] |
| Ship Weight lbs. [kg] | 1275 [578] | 1267 [575] | 1275 [578] | 1267 [575] |

NOTES:

1. Cooling Performance is rated at 95° F ambient, 80° F entering dry bulb, 67° F entering wet bulb. Gross capacity does not include the effect of fan motor heat. AHRI capacity is net and includes the effect of fan motor heat. Units are suitable for operation to ±20% of nominal cfm. Units are certified in accordance with the Unitary Air Conditioner Equipment certification program, which is based on AHRI Standard 340/360.
2. EER and/or SEER are rated at AHRI conditions and in accordance with DOE test procedures.
3. Integrated Energy Efficiency Ratio (IEER) is rated in accordance with AHRI Standard 340/360.
4. Outdoor Sound Rating shown is tested in accordance with AHRI Standard 270.

[] Designates Metric Conversions

NOM. SIZES 6-12.5 TONS [21.1-44.0 kW] ASHRAE 90.1-2010 COMPLIANT MODELS

| Model RLNL-C Series | C151YM |
|---|-------------------------|
| Cooling Performance¹ | |
| Gross Cooling Capacity Btu [kW] | 156,000 [45.71] |
| EER/SEER ² | 11.1/NA |
| Nominal CFM/AHRI Rated CFM [L/s] | 5000/4225 [2360/1994] |
| AHRI Net Cooling Capacity Btu [kW] | 150,000 [43.95] |
| Net Sensible Capacity Btu [kW] | 106,600 [31.23] |
| Net Latent Capacity Btu [kW] | 43,400 [12.72] |
| IEER ³ | 10.8 |
| Net System Power kW | 13.54 |
| Compressor | |
| No./Type | 2/Scroll |
| Outdoor Sound Rating (dB)⁴ | |
| 88 | |
| Outdoor Coil—Fin Type | |
| Louvered | |
| Tube Type | MicroChannel |
| Tube Size in. [mm] OD | 1 [25.4] |
| Face Area sq. ft. [sq. m] | 27 [2.51] |
| Rows / FPI [FPcm] | 2 / 23 [9] |
| Indoor Coil—Fin Type | |
| Louvered | |
| Tube Type | Rifled |
| Tube Size in. [mm] | 0.375 [9.5] |
| Face Area sq. ft. [sq. m] | 13.5 [1.25] |
| Rows / FPI [FPcm] | 4 / 15 [6] |
| Refrigerant Control | TX Valves |
| Drain Connection No./Size in. [mm] | 1/1 [25.4] |
| Outdoor Fan—Type | |
| Propeller | |
| No. Used/Diameter in. [mm] | 2/24 [609.6] |
| Drive Type/No. Speeds | Direct/1 |
| CFM [L/s] | 8000 [3775] |
| No. Motors/HP | 2 at 1/2 HP |
| Motor RPM | 1075 |
| Indoor Fan—Type | |
| FC Centrifugal | |
| No. Used/Diameter in. [mm] | 1/15x15 [381x381] |
| Drive Type/No. Speeds | Belt/Variable |
| No. Motors | 1 |
| Motor HP | 5 |
| Motor RPM | 1725 |
| Motor Frame Size | 184 |
| Filter—Type | |
| Disposable | |
| Furnished | Yes |
| (No.) Size Recommended in. [mm x mm x mm] | (6)2x18x18 [51x457x457] |
| Refrigerant Charge Oz. (Sys. 1/Sys. 2) [g] | |
| 147.2/152 [4173/4309] | |
| Weights | |
| Net Weight lbs. [kg] | 1238 [562] |
| Ship Weight lbs. [kg] | 1275 [578] |

NOTES:

1. Cooling Performance is rated at 95° F ambient, 80° F entering dry bulb, 67° F entering wet bulb. Gross capacity does not include the effect of fan motor heat. AHRI capacity is net and includes the effect of fan motor heat. Units are suitable for operation to $\pm 20\%$ of nominal cfm. Units are certified in accordance with the Unitary Air Conditioner Equipment certification program, which is based on AHRI Standard 340/360.
2. EER and/or SEER are rated at AHRI conditions and in accordance with DOE test procedures.
3. Integrated Energy Efficiency Ratio (IEER) is rated in accordance with AHRI Standard 340/360.
4. Outdoor Sound Rating shown is tested in accordance with AHRI Standard 270.

[] Designates Metric Conversions



SYSTEMS PERFORMANCE—RLNL-C SERIES

GROSS SYSTEMS PERFORMANCE DATA—C073

| | | ENTERING INDOOR AIR @ 80°F [26.7°C] dbE ① | | | | | | | | | |
|---|------------|--|-----------------------------------|-----------------------------------|-----------------------------------|-----------------------------------|-----------------------------------|-----------------------------------|-----------------------------------|-----------------------------------|-----------------------------------|
| wbE | | 71°F [21.7°C] | | | 67°F [19.4°C] | | | 63°F [17.2°C] | | | |
| CFM [L/s] | | 2790 [1317] | 2325 [1097] | 1860 [878] | 2790 [1317] | 2325 [1097] | 1860 [878] | 2790 [1317] | 2325 [1097] | 1860 [878] | |
| DR ① | | .06 | .01 | .15 | .06 | .01 | .15 | .06 | .01 | .15 | |
| OUTDOOR DRY BULB TEMPERATURE °F [°C] | 75 [23.9] | Total BTUH [kW] Sens BTUH [kW] Power | 92.8 [27.2] 58.8 [17.2] 4.7 | 89.5 [26.2] 50.5 [14.8] 4.6 | 86.3 [25.3] 42.9 [12.6] 4.5 | 86.4 [25.3] 67.9 [19.9] 4.6 | 83.4 [24.4] 59.1 [17.3] 4.5 | 80.3 [23.5] 50.8 [14.9] 4.5 | 81.8 [24.0] 75.4 [22.1] 4.6 | 78.9 [23.1] 66.1 [19.4] 4.5 | 76.1 [22.3] 57.4 [16.8] 4.4 |
| | 80 [26.7] | Total BTUH [kW] Sens BTUH [kW] Power | 90.8 [26.6] 58.1 [17.0] 4.9 | 87.6 [25.7] 49.9 [14.6] 4.8 | 84.4 [24.7] 42.3 [12.4] 4.7 | 84.4 [24.7] 67.0 [19.6] 4.9 | 81.4 [23.8] 58.3 [17.1] 4.8 | 78.5 [23.0] 50.2 [14.7] 4.7 | 79.8 [23.4] 74.7 [21.9] 4.8 | 77.0 [22.6] 65.5 [19.2] 4.7 | 74.2 [21.7] 56.8 [16.6] 4.7 |
| | 85 [29.4] | Total BTUH [kW] Sens BTUH [kW] Power | 88.6 [26.0] 57.0 [16.7] 5.2 | 85.5 [25.1] 49.0 [14.4] 5.1 | 82.4 [24.1] 41.6 [12.2] 5.0 | 82.2 [24.1] 66.0 [19.3] 5.1 | 79.4 [23.3] 57.6 [16.9] 5.1 | 76.5 [22.4] 49.6 [14.5] 5.0 | 77.7 [22.8] 73.7 [21.6] 5.1 | 74.9 [21.9] 64.6 [18.9] 5.0 | 72.2 [21.2] 56.1 [16.4] 4.9 |
| | 90 [32.2] | Total BTUH [kW] Sens BTUH [kW] Power | 86.3 [25.3] 55.9 [16.4] 5.5 | 83.2 [24.4] 48.0 [14.1] 5.4 | 80.2 [23.5] 40.8 [12.0] 5.3 | 79.9 [23.4] 64.9 [19.0] 5.4 | 77.1 [22.6] 56.6 [16.6] 5.3 | 74.3 [21.8] 48.8 [14.3] 5.2 | 75.3 [22.1] 72.5 [21.2] 5.4 | 72.7 [21.3] 63.7 [18.7] 5.3 | 70.0 [20.5] 55.3 [16.2] 5.2 |
| | 95 [35] | Total BTUH [kW] Sens BTUH [kW] Power | 83.7 [24.5] 54.4 [15.9] 5.8 | 80.8 [23.7] 46.9 [13.7] 5.7 | 77.9 [22.8] 39.9 [11.7] 5.6 | 77.4 [22.7] 63.6 [18.6] 5.7 | 74.7 [21.9] 55.5 [16.3] 5.6 | 71.9 [21.1] 47.8 [14.0] 5.5 | 72.8 [21.3] 71.2 [20.9] 5.7 | 70.2 [20.6] 62.5 [18.3] 5.6 | 67.7 [19.8] 54.4 [15.9] 5.5 |
| | 100 [37.8] | Total BTUH [kW] Sens BTUH [kW] Power | 81.0 [23.7] 52.9 [15.5] 6.1 | 78.2 [22.9] 45.6 [13.4] 6.0 | 75.4 [22.1] 38.8 [11.4] 5.9 | 74.7 [21.9] 62.1 [18.2] 6.1 | 72.1 [21.1] 54.2 [15.9] 6.0 | 69.4 [20.3] 46.7 [13.7] 5.9 | 70.1 [20.5] 69.6 [20.4] 6.0 | 67.6 [19.8] 61.2 [17.9] 5.9 | 65.2 [19.1] 53.3 [15.6] 5.8 |
| | 105 [40.6] | Total BTUH [kW] Sens BTUH [kW] Power | 78.2 [22.9] 51.3 [15.0] 6.5 | 75.4 [22.1] 44.1 [12.9] 6.4 | 72.7 [21.3] 37.5 [11.0] 6.2 | 71.8 [21.0] 60.2 [17.6] 6.4 | 69.3 [20.3] 52.6 [15.4] 6.3 | 66.8 [19.6] 45.4 [13.3] 6.2 | 67.2 [19.7] 67.2 [19.7] 6.4 | 64.8 [19.0] 59.7 [17.5] 6.3 | 62.5 [18.3] 52.0 [15.2] 6.2 |
| | 110 [43.3] | Total BTUH [kW] Sens BTUH [kW] Power | 75.1 [22.0] 49.2 [14.4] 6.8 | 72.5 [21.2] 42.4 [12.4] 6.7 | 69.8 [20.5] 36.0 [10.5] 6.6 | 68.7 [20.1] 58.3 [17.1] 6.8 | 66.3 [19.4] 50.9 [14.9] 6.7 | 63.9 [18.7] 44.0 [12.9] 6.6 | 64.2 [18.8] 64.2 [18.8] 6.8 | 61.9 [18.1] 58.0 [17.0] 6.6 | 59.6 [17.5] 50.5 [14.8] 6.5 |
| | 115 [46.1] | Total BTUH [kW] Sens BTUH [kW] Power | 71.9 [21.1] 47.1 [13.8] 7.2 | 69.3 [20.3] 40.5 [11.9] 7.1 | 66.8 [19.6] 34.5 [10.1] 7.0 | 65.5 [19.2] 56.2 [16.5] 7.2 | 63.2 [18.5] 49.1 [14.4] 7.1 | 60.9 [17.8] 42.4 [12.4] 6.9 | 60.9 [17.8] 60.9 [17.8] 7.1 | 58.8 [17.2] 56.2 [16.5] 7.0 | 56.6 [16.6] 49.0 [14.4] 6.9 |

GROSS SYSTEMS PERFORMANCE DATA—C090

| | | ENTERING INDOOR AIR @ 80°F [26.7°C] dbE ① | | | | | | | | | |
|---|------------|--|------------------------------------|------------------------------------|------------------------------------|------------------------------------|------------------------------------|-----------------------------------|------------------------------------|-----------------------------------|-----------------------------------|
| wbE | | 71°F [21.7°C] | | | 67°F [19.4°C] | | | 63°F [17.2°C] | | | |
| CFM [L/s] | | 3600 [1699] | 2775 [1310] | 2440 [1152] | 3600 [1699] | 2775 [1310] | 2440 [1152] | 3600 [1699] | 2775 [1310] | 2440 [1152] | |
| DR ① | | .06 | .13 | .17 | .06 | .13 | .17 | .06 | .13 | .17 | |
| OUTDOOR DRY BULB TEMPERATURE °F [°C] | 75 [23.9] | Total BTUH [kW] Sens BTUH [kW] Power | 111.2 [32.6] 68.2 [20.0] 5.8 | 105.5 [30.9] 54.2 [15.9] 5.6 | 102.9 [30.2] 48.3 [14.2] 5.6 | 107.2 [31.4] 84.6 [24.8] 5.7 | 101.7 [29.8] 68.8 [20.2] 5.6 | 99.2 [29.1] 62.1 [18.2] 5.5 | 101.3 [29.7] 93.5 [27.4] 5.7 | 96.1 [28.2] 76.9 [22.5] 5.5 | 93.8 [27.5] 69.9 [20.5] 5.4 |
| | 80 [26.7] | Total BTUH [kW] Sens BTUH [kW] Power | 109.7 [32.1] 68.3 [20.0] 6.1 | 104.0 [30.5] 54.3 [15.9] 6.0 | 101.5 [29.7] 48.5 [14.2] 5.9 | 105.7 [31.0] 84.6 [24.8] 6.0 | 100.3 [29.4] 68.9 [20.2] 5.9 | 97.8 [28.7] 62.2 [18.2] 5.8 | 99.8 [29.2] 93.5 [27.4] 6.0 | 94.7 [27.8] 77.0 [22.6] 5.8 | 92.3 [27.1] 69.9 [20.5] 5.8 |
| | 85 [29.4] | Total BTUH [kW] Sens BTUH [kW] Power | 107.7 [31.6] 67.8 [19.9] 6.5 | 102.2 [30.0] 54.0 [15.8] 6.3 | 99.7 [29.2] 48.3 [14.2] 6.2 | 103.7 [30.4] 84.0 [24.6] 6.4 | 98.4 [28.8] 68.5 [20.1] 6.2 | 96.0 [28.1] 61.9 [18.2] 6.2 | 97.8 [28.7] 92.9 [27.2] 6.3 | 92.8 [27.2] 76.6 [22.5] 6.2 | 90.5 [26.5] 69.6 [20.4] 6.1 |
| | 90 [32.2] | Total BTUH [kW] Sens BTUH [kW] Power | 105.3 [30.9] 66.6 [19.5] 6.8 | 99.9 [29.3] 53.1 [15.6] 6.7 | 97.5 [28.6] 47.5 [13.9] 6.6 | 101.4 [29.7] 83.1 [24.4] 6.8 | 96.2 [28.2] 67.8 [19.9] 6.6 | 93.8 [27.5] 61.3 [18.0] 6.5 | 95.4 [28.0] 91.9 [26.9] 6.7 | 90.5 [26.5] 75.8 [22.2] 6.5 | 88.3 [25.9] 69.0 [20.2] 6.4 |
| | 95 [35] | Total BTUH [kW] Sens BTUH [kW] Power | 102.5 [30.0] 65.1 [19.1] 7.2 | 97.3 [28.5] 52.0 [15.2] 7.0 | 94.9 [27.8] 46.5 [13.6] 6.9 | 98.5 [28.9] 81.5 [23.9] 7.2 | 93.5 [27.4] 66.6 [19.5] 7.0 | 91.2 [26.7] 60.2 [17.7] 6.9 | 92.6 [27.1] 90.4 [26.5] 7.1 | 87.9 [25.8] 74.7 [21.9] 6.9 | 85.7 [25.1] 67.9 [19.9] 6.8 |
| | 100 [37.8] | Total BTUH [kW] Sens BTUH [kW] Power | 99.3 [29.1] 63.2 [18.5] 7.6 | 94.2 [27.6] 50.4 [14.8] 7.4 | 91.9 [26.9] 45.1 [13.2] 7.3 | 95.3 [27.9] 79.6 [23.3] 7.6 | 90.4 [26.5] 65.0 [19.1] 7.4 | 88.2 [25.8] 58.8 [17.2] 7.3 | 89.4 [26.2] 88.4 [25.9] 7.5 | 84.8 [24.9] 73.0 [21.4] 7.3 | 82.7 [24.2] 66.4 [19.5] 7.2 |
| | 105 [40.6] | Total BTUH [kW] Sens BTUH [kW] Power | 95.6 [28.0] 60.6 [17.8] 8.1 | 90.7 [26.6] 48.3 [14.2] 7.9 | 88.5 [25.9] 43.2 [12.7] 7.8 | 91.6 [26.8] 77.0 [22.6] 8.0 | 86.9 [25.5] 62.9 [18.4] 7.8 | 84.8 [24.9] 57.0 [16.7] 7.7 | 85.7 [25.1] 85.7 [25.1] 7.9 | 81.3 [23.8] 71.0 [20.8] 7.7 | 79.3 [23.2] 64.6 [18.9] 7.6 |
| | 110 [43.3] | Total BTUH [kW] Sens BTUH [kW] Power | 91.5 [26.8] 57.6 [16.9] 8.5 | 86.8 [25.4] 45.9 [13.5] 8.3 | 84.7 [24.8] 41.0 [12.0] 8.2 | 87.5 [25.6] 73.9 [21.7] 8.4 | 83.0 [24.3] 60.4 [17.7] 8.2 | 81.0 [23.7] 54.7 [16.0] 8.1 | 81.6 [23.9] 81.6 [23.9] 8.4 | 77.4 [22.7] 68.5 [20.1] 8.2 | 75.5 [22.1] 62.4 [18.3] 8.1 |
| | 115 [46.1] | Total BTUH [kW] Sens BTUH [kW] Power | 87.0 [25.5] 54.1 [15.9] 9.0 | 82.5 [24.2] 43.0 [12.6] 8.8 | 80.5 [23.6] 38.4 [11.3] 8.6 | 83.0 [24.3] 70.5 [20.7] 8.9 | 78.7 [23.1] 57.6 [16.9] 8.7 | 76.8 [22.5] 52.2 [15.3] 8.6 | 77.1 [22.6] 77.1 [22.6] 8.8 | 73.1 [21.4] 65.7 [19.3] 8.6 | 71.3 [20.9] 59.9 [17.6] 8.5 |

DR —Depression ratio
dbE—Entering air dry bulb
wbE—Entering air wet bulb

Total —Total capacity x 1000 BTUH
Sens —Sensible capacity x 1000 BTUH
Power—KW input

NOTES: ① When the entering air dry bulb is other than 80°F [27°C], adjust the sensible capacity from the table by adding $[1.10 \times \text{CFM} \times (1 - \text{DR}) \times (\text{dbE} - 80)]$.

[] Designates Metric Conversions



GROSS SYSTEMS PERFORMANCE DATA—C102

| | | ENTERING INDOOR AIR @ 80°F [26.7°C] ① | | | | | | | | | |
|--|--|--|------------------------------------|------------------------------------|------------------------------------|------------------------------------|------------------------------------|------------------------------------|-------------------------------------|-----------------------------------|-----------------------------------|
| wbE | | 71°F [21.7°C] | | | 67°F [19.4°C] | | | 63°F [17.2°C] | | | |
| CFM [L/s] | | 4100 [1935] | 3200 [1510] | 2700 [1274] | 4100 [1935] | 3200 [1510] | 2700 [1274] | 4100 [1935] | 3200 [1510] | 2700 [1274] | |
| DR ① | | 0 | .05 | .08 | 0 | .05 | .08 | 0 | .05 | .08 | |
| OUTDOOR DRY BULB TEMPERATURE °F [°C] | 75 [23.9] | Total BTUH [kW] Sens BTUH [kW] Power | 113.8 [33.4] 69.9 [20.5] 6.4 | 108.3 [31.7] 56.3 [16.5] 6.3 | 105.2 [30.8] 49.3 [14.5] 6.2 | 110.1 [32.3] 91.3 [26.8] 6.3 | 104.7 [30.7] 75.3 [22.1] 6.2 | 101.7 [29.8] 67.0 [19.6] 6.1 | 105.0 [30.8] 103.1 [30.2] 6.2 | 99.9 [29.3] 86.0 [25.2] 6.1 | 97.0 [28.4] 77.0 [22.6] 6.0 |
| | 80 [26.7] | Total BTUH [kW] Sens BTUH [kW] Power | 113.7 [33.3] 71.7 [21.0] 6.7 | 108.2 [31.7] 57.9 [17.0] 6.6 | 105.1 [30.8] 50.8 [14.9] 6.5 | 110.0 [32.2] 93.1 [27.3] 6.7 | 104.6 [30.7] 76.9 [22.5] 6.5 | 101.7 [29.8] 68.6 [20.1] 6.4 | 104.9 [30.7] 104.9 [30.8] 6.6 | 99.8 [29.2] 87.6 [25.7] 6.4 | 96.9 [28.4] 78.5 [23.0] 6.3 |
| | 85 [29.4] | Total BTUH [kW] Sens BTUH [kW] Power | 112.9 [33.1] 72.6 [21.3] 7.1 | 107.5 [31.5] 58.8 [17.2] 6.9 | 104.4 [30.6] 51.6 [15.1] 6.8 | 109.2 [32.0] 94.0 [27.6] 7.0 | 103.9 [30.5] 77.8 [22.8] 6.8 | 101.0 [29.6] 69.4 [20.3] 6.7 | 104.1 [30.5] 104.1 [30.5] 6.9 | 99.1 [29.0] 88.5 [25.9] 6.7 | 96.2 [28.2] 79.4 [23.3] 6.7 |
| | 90 [32.2] | Total BTUH [kW] Sens BTUH [kW] Power | 111.5 [32.7] 72.9 [21.4] 7.4 | 106.1 [31.1] 59.0 [17.3] 7.3 | 103.1 [30.2] 51.9 [15.2] 7.2 | 107.8 [31.6] 94.2 [27.6] 7.4 | 102.5 [30.0] 78.0 [22.9] 7.2 | 99.6 [29.2] 69.6 [20.4] 7.1 | 102.7 [30.1] 102.7 [30.1] 7.3 | 97.7 [28.6] 88.7 [26.0] 7.1 | 94.9 [27.8] 79.6 [23.3] 7.0 |
| | 95 [35] | Total BTUH [kW] Sens BTUH [kW] Power | 109.4 [32.1] 72.2 [21.2] 7.8 | 104.1 [30.5] 58.5 [17.2] 7.6 | 101.1 [29.6] 51.5 [15.1] 7.5 | 105.7 [31.0] 93.6 [27.4] 7.7 | 100.5 [29.5] 77.5 [22.7] 7.6 | 97.7 [28.6] 69.3 [20.3] 7.4 | 100.6 [29.5] 100.6 [29.5] 7.7 | 95.7 [28.0] 88.2 [25.9] 7.5 | 93.0 [27.3] 79.3 [23.3] 7.4 |
| | 100 [37.8] | Total BTUH [kW] Sens BTUH [kW] Power | 106.6 [31.2] 70.7 [20.7] 8.2 | 101.4 [29.7] 57.3 [16.8] 8.0 | 98.6 [28.9] 50.5 [14.8] 7.9 | 102.9 [30.2] 92.1 [27.0] 8.1 | 97.9 [28.7] 76.4 [22.4] 8.0 | 95.1 [27.9] 68.2 [20.0] 7.8 | 97.8 [28.7] 97.8 [28.7] 8.1 | 93.0 [27.3] 87.0 [25.5] 7.9 | 90.4 [26.5] 78.2 [22.9] 7.8 |
| | 105 [40.6] | Total BTUH [kW] Sens BTUH [kW] Power | 103.2 [30.2] 68.4 [20.1] 8.7 | 98.1 [28.8] 55.4 [16.2] 8.4 | 95.4 [28.0] 48.9 [14.3] 8.3 | 99.4 [29.1] 89.7 [26.3] 8.6 | 94.6 [27.7] 74.5 [21.8] 8.4 | 91.9 [26.9] 66.6 [19.5] 8.2 | 94.3 [27.6] 94.3 [27.6] 8.5 | 89.8 [26.3] 85.2 [25.0] 8.3 | 87.2 [25.6] 76.6 [22.5] 8.2 |
| | 110 [43.3] | Total BTUH [kW] Sens BTUH [kW] Power | 99.0 [29.0] 65.2 [19.1] 9.1 | 94.2 [27.6] 52.8 [15.5] 8.9 | 91.5 [26.8] 46.4 [13.6] 8.8 | 95.3 [27.9] 86.7 [25.4] 9.0 | 90.7 [26.6] 72.0 [21.1] 8.8 | 88.1 [25.8] 64.3 [18.9] 8.7 | 90.2 [26.4] 90.2 [26.4] 8.9 | 85.8 [25.1] 82.5 [24.2] 8.7 | 83.4 [24.4] 74.3 [21.8] 8.6 |
| 115 [46.1] | Total BTUH [kW] Sens BTUH [kW] Power | 94.2 [27.6] 61.3 [18.0] 9.6 | 89.6 [26.3] 49.6 [14.5] 9.3 | 87.1 [25.5] 43.7 [12.8] 9.2 | 90.5 [26.5] 82.7 [24.2] 9.5 | 86.1 [25.2] 68.7 [20.1] 9.3 | 83.7 [24.5] 61.5 [18.0] 9.1 | 85.4 [25.0] 85.4 [25.0] 9.4 | 81.3 [23.8] 79.4 [23.3] 9.2 | 78.9 [23.1] 71.4 [20.9] 9.1 | |

GROSS SYSTEMS PERFORMANCE DATA—C120

| | | ENTERING INDOOR AIR @ 80°F [26.7°C] dbE ① | | | | | | | | | |
|--|--|--|-------------------------------------|-------------------------------------|--------------------------------------|--------------------------------------|-------------------------------------|--------------------------------------|--------------------------------------|--------------------------------------|-------------------------------------|
| wbE | | 71°F [21.7°C] | | | 67°F [19.4°C] | | | 63°F [17.2°C] | | | |
| CFM [L/s] | | 4800 [2265] | 3750 [1770] | 3200 [1510] | 4800 [2265] | 3750 [1770] | 3200 [1510] | 4800 [2265] | 3750 [1770] | 3200 [1510] | |
| DR ① | | 0 | .03 | .07 | 0 | .03 | .07 | 0 | .03 | .07 | |
| OUTDOOR DRY BULB TEMPERATURE °F [°C] | 75 [23.9] | Total BTUH [kW] Sens BTUH [kW] Power | 149.3 [43.8] 99.7 [29.2] 7.3 | 142.1 [41.6] 81.0 [23.7] 7.2 | 138.3 [40.5] 71.9 [21.1] 7.1 | 139.6 [40.9] 117.9 [34.6] 7.2 | 132.8 [38.9] 97.5 [28.6] 7.0 | 129.3 [37.9] 87.6 [25.7] 6.9 | 130.9 [38.4] 130.9 [38.4] 7.1 | 124.6 [36.5] 109.7 [32.2] 6.9 | 121.3 [35.5] 99.1 [29.1] 6.8 |
| | 80 [26.7] | Total BTUH [kW] Sens BTUH [kW] Power | 147.2 [43.1] 99.2 [29.1] 7.8 | 140.0 [41.0] 80.5 [23.6] 7.6 | 136.3 [39.9] 71.5 [21.0] 7.5 | 137.4 [40.3] 117.1 [34.3] 7.7 | 130.8 [38.3] 97.0 [28.4] 7.5 | 127.3 [37.3] 87.1 [25.5] 7.4 | 128.8 [37.7] 128.8 [37.8] 7.6 | 122.6 [35.9] 109.3 [32.0] 7.4 | 119.3 [35.0] 98.7 [28.9] 7.3 |
| | 85 [29.4] | Total BTUH [kW] Sens BTUH [kW] Power | 144.7 [42.4] 98.0 [28.7] 8.3 | 137.7 [40.4] 79.7 [23.4] 8.1 | 134.0 [39.3] 70.8 [20.8] 8.0 | 135.0 [39.6] 116.2 [34.1] 8.2 | 128.5 [37.7] 96.3 [28.2] 8.0 | 125.0 [36.6] 86.4 [25.3] 7.9 | 126.4 [37.0] 126.4 [37.1] 8.0 | 120.2 [35.2] 108.4 [31.8] 7.8 | 117.0 [34.3] 98.0 [28.7] 7.7 |
| | 90 [32.2] | Total BTUH [kW] Sens BTUH [kW] Power | 142.0 [41.6] 96.8 [28.4] 8.8 | 135.1 [39.6] 78.7 [23.1] 8.6 | 131.5 [38.5] 70.0 [20.5] 8.5 | 132.3 [38.8] 114.9 [33.7] 8.7 | 125.9 [36.9] 95.2 [27.9] 8.5 | 122.5 [35.9] 85.5 [25.1] 8.4 | 123.6 [36.2] 123.6 [36.2] 8.6 | 117.7 [34.5] 107.5 [31.5] 8.4 | 114.5 [33.6] 97.2 [28.5] 8.3 |
| | 95 [35] | Total BTUH [kW] Sens BTUH [kW] Power | 139.0 [40.7] 95.1 [27.9] 9.4 | 132.3 [38.8] 77.4 [22.7] 9.1 | 128.8 [37.7] 68.8 [20.2] 9.0 | 129.3 [37.9] 113.2 [33.2] 9.2 | 123.0 [36.0] 93.8 [27.5] 9.0 | 119.7 [35.1] 84.3 [24.7] 8.9 | 120.7 [35.4] 120.7 [35.4] 9.1 | 114.8 [33.6] 106.1 [31.1] 8.9 | 111.8 [32.8] 96.0 [28.1] 8.8 |
| | 100 [37.8] | Total BTUH [kW] Sens BTUH [kW] Power | 135.8 [39.8] 93.1 [27.3] 9.9 | 129.2 [37.9] 75.7 [22.2] 9.7 | 125.7 [36.8] 67.3 [19.7] 9.6 | 126.0 [36.9] 111.1 [32.6] 9.8 | 119.9 [35.1] 92.2 [27.0] 9.6 | 116.7 [34.2] 82.9 [24.3] 9.5 | 117.4 [34.4] 117.4 [34.4] 9.7 | 111.7 [32.7] 104.4 [30.6] 9.5 | 108.7 [31.9] 94.5 [27.7] 9.3 |
| | 105 [40.6] | Total BTUH [kW] Sens BTUH [kW] Power | 132.2 [38.7] 90.7 [26.6] 10.6 | 125.8 [36.9] 73.8 [21.6] 10.3 | 122.5 [35.9] 65.7 [19.3] 10.2 | 122.5 [35.9] 108.8 [31.9] 10.4 | 116.5 [34.1] 90.2 [26.4] 10.2 | 113.4 [33.2] 81.1 [23.8] 10.1 | 113.8 [33.4] 113.8 [33.4] 10.3 | 108.3 [31.7] 102.5 [30.0] 10.1 | 105.4 [30.9] 92.8 [27.2] 9.9 |
| | 110 [43.3] | Total BTUH [kW] Sens BTUH [kW] Power | 128.4 [37.6] 88.0 [25.8] 11.2 | 122.2 [35.8] 71.6 [21.0] 10.9 | 118.9 [34.8] 63.6 [18.6] 10.8 | 118.7 [34.8] 106.2 [31.1] 11.1 | 112.9 [33.1] 88.1 [25.8] 10.8 | 109.9 [32.2] 79.3 [23.3] 10.7 | 110.0 [32.2] 110.0 [32.2] 11.0 | 104.7 [30.7] 100.3 [29.4] 10.7 | 101.9 [29.9] 90.8 [26.6] 10.6 |
| 115 [46.1] | Total BTUH [kW] Sens BTUH [kW] Power | 124.3 [36.4] 85.0 [24.9] 11.9 | 118.3 [34.7] 69.2 [20.3] 11.6 | 115.1 [33.7] 61.5 [18.0] 11.4 | 114.6 [33.6] 103.1 [30.2] 11.7 | 109.0 [31.9] 85.6 [25.1] 11.5 | 106.1 [31.1] 77.0 [22.6] 11.3 | 105.9 [31.0] 105.9 [31.0] 11.6 | 100.8 [29.5] 97.9 [28.7] 11.3 | 98.1 [28.8] 88.7 [26.0] 11.2 | |

DR —Depression ratio
dbE—Entering air dry bulb
wbE—Entering air wet bulb

Total —Total capacity x 1000 BTUH
Sens —Sensible capacity x 1000 BTUH
Power—KW input

NOTES: ① When the entering air dry bulb is other than 80°F [27°C], adjust the sensible capacity from the table by adding [1.10 x CFM x (1 - DR) x (dbE - 80)].

[] Designates Metric Conversions



GROSS SYSTEMS PERFORMANCE DATA—C151

| | | ENTERING INDOOR AIR @ 80°F [26.7°C] ① | | | | | | | | | |
|--------------------------------------|------------|--|--------------------------------------|--------------------------------------|-------------------------------------|--------------------------------------|--------------------------------------|--------------------------------------|--------------------------------------|--------------------------------------|--------------------------------------|
| | | 71°F [21.7°C] | | | 67°F [19.4°C] | | | 63°F [17.2°C] | | | |
| wbE | | 5800 [2737] | 4225 [1994] | 3800 [1793] | 5800 [2737] | 4225 [1994] | 3800 [1793] | 5800 [2737] | 4225 [1994] | 3800 [1793] | |
| CFM [L/s] | | 5800 [2737] | 4225 [1994] | 3800 [1793] | 5800 [2737] | 4225 [1994] | 3800 [1793] | 5800 [2737] | 4225 [1994] | 3800 [1793] | |
| DR ① | | 0 | .03 | .06 | 0 | .03 | .06 | 0 | .03 | .06 | |
| OUTDOOR DRY BULB TEMPERATURE °F [°C] | 75 [23.9] | Total BTUH [kW] Sens BTUH [kW] Power | 196.8 [57.7] 135.5 [39.7] 10.2 | 184.4 [54.0] 103.0 [30.2] 9.9 | 181.0 [53.0] 94.9 [27.8] 9.8 | 186.8 [54.7] 156.7 [45.9] 10.0 | 175.0 [51.3] 121.7 [35.7] 9.7 | 171.8 [50.3] 112.9 [33.1] 9.6 | 178.6 [52.3] 177.9 [52.1] 9.7 | 167.3 [49.0] 140.2 [41.1] 9.4 | 164.2 [48.1] 130.7 [38.3] 9.3 |
| | 80 [26.7] | Total BTUH [kW] Sens BTUH [kW] Power | 192.1 [56.3] 132.7 [38.9] 10.7 | 179.9 [52.7] 100.8 [29.6] 10.3 | 176.6 [51.8] 92.9 [27.2] 10.3 | 182.1 [53.4] 153.9 [45.1] 10.5 | 170.6 [50.0] 119.6 [35.1] 10.1 | 167.4 [49.1] 110.9 [32.5] 10.0 | 173.9 [51.0] 173.9 [51.0] 10.2 | 162.9 [47.7] 138.2 [40.5] 9.9 | 159.9 [46.9] 128.9 [37.8] 9.8 |
| | 85 [29.4] | Total BTUH [kW] Sens BTUH [kW] Power | 187.2 [54.9] 129.7 [38.0] 11.2 | 175.3 [51.4] 98.6 [28.9] 10.9 | 172.1 [50.4] 90.9 [26.7] 10.8 | 177.2 [51.9] 151.1 [44.3] 11.0 | 166.0 [48.6] 117.5 [34.4] 10.6 | 162.9 [47.7] 109.0 [32.0] 10.5 | 169.0 [49.5] 169.0 [49.5] 10.7 | 158.3 [46.4] 136.0 [39.9] 10.4 | 155.4 [45.5] 126.9 [37.2] 10.3 |
| | 90 [32.2] | Total BTUH [kW] Sens BTUH [kW] Power | 182.1 [53.4] 126.8 [37.2] 11.8 | 170.5 [50.0] 96.4 [28.3] 11.4 | 167.4 [49.1] 88.9 [26.1] 11.3 | 172.1 [50.4] 148.0 [43.4] 11.5 | 161.2 [47.2] 115.2 [33.8] 11.2 | 158.2 [46.4] 106.9 [31.3] 11.1 | 163.9 [48.0] 163.9 [48.0] 11.3 | 153.5 [45.0] 133.7 [39.2] 10.9 | 150.7 [44.2] 124.8 [36.6] 10.8 |
| | 95 [35] | Total BTUH [kW] Sens BTUH [kW] Power | 176.8 [51.8] 123.6 [36.2] 12.3 | 165.6 [48.5] 94.1 [27.6] 11.9 | 162.5 [47.6] 86.7 [25.4] 11.8 | 166.8 [48.9] 144.9 [42.5] 12.1 | 156.2 [45.8] 112.8 [33.1] 11.7 | 153.3 [44.9] 104.7 [30.7] 11.6 | 158.6 [46.5] 158.6 [46.5] 11.9 | 148.5 [43.5] 131.3 [38.5] 11.5 | 145.8 [42.7] 122.6 [35.9] 11.4 |
| | 100 [37.8] | Total BTUH [kW] Sens BTUH [kW] Power | 171.3 [50.2] 120.3 [35.3] 13.0 | 160.4 [47.0] 91.6 [26.9] 12.5 | 157.5 [46.2] 84.5 [24.8] 12.4 | 161.3 [47.3] 141.6 [41.5] 12.7 | 151.0 [44.3] 110.3 [32.3] 12.3 | 148.3 [43.5] 102.5 [30.0] 12.2 | 153.1 [44.9] 153.1 [44.9] 12.5 | 143.3 [42.0] 128.8 [37.8] 12.1 | 140.7 [41.2] 120.3 [35.3] 12.0 |
| | 105 [40.6] | Total BTUH [kW] Sens BTUH [kW] Power | 165.6 [48.5] 116.9 [34.3] 13.6 | 155.1 [45.5] 89.1 [26.1] 13.2 | 152.2 [44.6] 82.2 [24.1] 13.0 | 155.6 [45.6] 138.2 [40.5] 13.4 | 145.7 [42.7] 107.8 [31.6] 12.9 | 143.0 [41.9] 100.2 [29.4] 12.8 | 147.4 [43.2] 147.4 [43.2] 13.1 | 138.0 [40.4] 126.3 [37.0] 12.7 | 135.5 [39.7] 118.0 [34.6] 12.6 |
| | 110 [43.3] | Total BTUH [kW] Sens BTUH [kW] Power | 159.7 [46.8] 113.4 [33.2] 14.3 | 149.6 [43.8] 86.5 [25.4] 13.8 | 146.8 [43.0] 79.8 [23.4] 13.7 | 149.7 [43.9] 134.7 [39.5] 14.0 | 140.2 [41.1] 105.2 [30.8] 13.6 | 137.6 [40.3] 97.8 [28.7] 13.5 | 141.5 [41.5] 141.5 [41.5] 13.8 | 132.5 [38.8] 123.7 [36.3] 13.4 | 130.1 [38.1] 115.6 [33.9] 13.3 |
| | 115 [46.1] | Total BTUH [kW] Sens BTUH [kW] Power | 153.6 [45.0] 109.8 [32.2] 15.0 | 143.9 [42.2] 83.8 [24.6] 14.5 | 141.2 [41.4] 77.3 [22.7] 14.4 | 143.6 [42.1] 131.0 [38.4] 14.7 | 134.5 [39.4] 102.5 [30.0] 14.3 | 132.0 [38.7] 95.3 [27.9] 14.2 | 135.4 [39.7] 135.4 [39.7] 14.5 | 126.8 [37.2] 121.0 [35.5] 14.1 | 124.5 [36.5] 113.1 [33.2] 13.9 |

DR —Depression ratio
dbE—Entering air dry bulb
wbE—Entering air wet bulb

Total —Total capacity x 1000 BTUH
Sens —Sensible capacity x 1000 BTUH
Power—KW input

NOTES: ① When the entering air dry bulb is other than 80°F [27°C], adjust the sensible capacity from the table by adding [1.10 x CFM x (1 – DR) x (dbE – 80)].

[] Designates Metric Conversions



AIRFLOW PERFORMANCE—10 TON [35.2 kW]

| Air Flow CFM [L/s] | Capacity 10 Ton [35.2 kW] | | | | | | | | | | | | | | | | | | | |
|--------------------|--|------------|------------|------------|------------|------------|------------|------------|------------|------------|------------|------------|------------|------------|------------|------------|------------|------------|------------|------------|
| | External Static Pressure—Inches of Water [kPa] | | | | | | | | | | | | | | | | | | | |
| | 0.1 [0.02] | 0.2 [0.05] | 0.3 [0.07] | 0.4 [0.10] | 0.5 [0.12] | 0.6 [0.15] | 0.7 [0.17] | 0.8 [0.20] | 0.9 [0.22] | 1.0 [0.25] | 1.1 [0.27] | 1.2 [0.30] | 1.3 [0.32] | 1.4 [0.35] | 1.5 [0.37] | 1.6 [0.40] | 1.7 [0.42] | 1.8 [0.45] | 1.9 [0.47] | 2.0 [0.50] |
| 3200 [1510] | — | — | — | — | — | — | — | — | — | — | — | — | — | — | — | — | — | — | — | — |
| 3300 [1537] | — | — | — | — | — | — | — | — | — | — | — | — | — | — | — | — | — | — | — | — |
| 3400 [1605] | — | — | — | — | — | — | — | — | — | — | — | — | — | — | — | — | — | — | — | — |
| 3500 [1652] | — | — | — | — | — | — | — | — | — | — | — | — | — | — | — | — | — | — | — | — |
| 3600 [1699] | — | — | — | — | — | — | — | — | — | — | — | — | — | — | — | — | — | — | — | — |
| 3700 [1746] | 672 | 1361 | 740 | 1435 | 727 | 1510 | 755 | 1584 | 782 | 1659 | 810 | 1733 | 837 | 1808 | 865 | 1882 | 933 | 1896 | 953 | 1956 |
| 3800 [1793] | 686 | 1443 | 713 | 1518 | 741 | 1592 | 768 | 1667 | 796 | 1741 | 823 | 1818 | 861 | 1890 | 878 | 1965 | 940 | 2003 | 960 | 2075 |
| 3900 [1841] | 699 | 1526 | 727 | 1601 | 754 | 1675 | 782 | 1750 | 809 | 1824 | 837 | 1899 | 864 | 1973 | 927 | 2015 | 948 | 2080 | 968 | 2194 |
| 4000 [1888] | 713 | 1609 | 740 | 1683 | 768 | 1758 | 795 | 1832 | 823 | 1907 | 850 | 1961 | 878 | 2056 | 935 | 2085 | 955 | 2199 | 975 | 2312 |
| 4100 [1935] | 726 | 1692 | 754 | 1766 | 781 | 1841 | 809 | 1915 | 836 | 1990 | 864 | 2064 | 922 | 2091 | 942 | 2204 | 963 | 2318 | 983 | 2431 |
| 4200 [1982] | 740 | 1774 | 767 | 1849 | 795 | 1923 | 822 | 1998 | 850 | 2072 | 877 | 2147 | 930 | 2209 | 950 | 2323 | 970 | 2438 | 990 | 2550 |
| 4300 [2029] | 753 | 1857 | 781 | 1932 | 808 | 2006 | 836 | 2081 | 853 | 2155 | 917 | 2215 | 937 | 2328 | 957 | 2442 | 978 | 2555 | 998 | 2669 |
| 4400 [2077] | 767 | 1940 | 794 | 2014 | 822 | 2089 | 849 | 2163 | 877 | 2238 | 924 | 2333 | 945 | 2447 | 965 | 2560 | 985 | 2674 | 1006 | 2787 |
| 4500 [2124] | 780 | 2023 | 808 | 2097 | 835 | 2172 | 863 | 2248 | 912 | 2338 | 932 | 2452 | 952 | 2565 | 973 | 2679 | 993 | 2793 | 1013 | 2906 |
| 4600 [2171] | 794 | 2105 | 821 | 2180 | 840 | 2254 | 876 | 2329 | 919 | 2457 | 940 | 2571 | 960 | 2684 | 980 | 2798 | 1000 | 2911 | 1021 | 3025 |
| 4700 [2218] | 807 | 2188 | 835 | 2263 | 862 | 2337 | 906 | 2462 | 927 | 2576 | 947 | 2689 | 967 | 2803 | 988 | 2916 | 1008 | 3030 | 1028 | 3143 |
| 4800 [2265] | 821 | 2271 | 848 | 2345 | 876 | 2420 | 914 | 2581 | 934 | 2695 | 955 | 2808 | 975 | 2922 | 995 | 3035 | 1015 | 3149 | 1036 | 3262 |

NOTE: L- Drive left of bold line, M- Drive right of bold line.

| Drive Package | L | | | | | | M | | | | | |
|----------------|--------------|-----|-----|-----|-----|-----|--------------|------|------|-----|-----|-----|
| Motor H.P. [W] | 2.0 [1491.4] | | | | | | 3.0 [2237.1] | | | | | |
| Blower Sheave | BK90 | | | | | | BK65 | | | | | |
| Motor Sheave | 1VP-44 | | | | | | 1VP-44 | | | | | |
| Turns Open | 1 | 2 | 3 | 4 | 5 | 6 | 1 | 2 | 3 | 4 | 5 | 6 |
| RPM | 845 | 810 | 775 | 739 | 704 | 669 | 1138 | 1089 | 1041 | 992 | 943 | 894 |

- NOTES: 1. Factory sheave settings are shown in bold print.
 2. Re-adjustment of sheave required to achieve rated airflow at AHRI minimum E.S.P.
 3. Do not operate above blower RPM shown as motor overloading will occur.
 4. Do not set motor sheave below one turn open.

COMPONENT AIR RESISTANCE, IWC 10 TON [35.2 kW]

| Component | Standard Indoor Airflow—CFM [L/s] | | | | | | | | | | | | |
|--|-----------------------------------|---------------|---------------|---------------|---------------|---------------|---------------|---------------|---------------|--------------|--------------|--------------|--------------|
| | Resistance—Inches Water [kPa] | | | | | | | | | | | | |
| | 3200 [1510] | 3400 [1604] | 3600 [1699] | 3800 [1793] | 4000 [1888] | 4200 [1982] | 4400 [2076] | 4600 [2171] | 4800 [2265] | | | | |
| Wet Coil | 0.065 [0.016] | 0.071 [0.018] | 0.076 [0.019] | 0.082 [0.020] | 0.087 [0.022] | 0.093 [0.023] | 0.099 [0.026] | 0.105 [0.027] | 0.110 [0.027] | DNA | DNA | DNA | DNA |
| Concentric Diffuser RXRN-FA65 or FA75 & Transition RXMC-CD04 | 0.31 [0.077] | 0.37 [0.092] | DNA | DNA | DNA | DNA | DNA | DNA | DNA | DNA | DNA | DNA | DNA |
| Concentric Diffuser RXRN-AA61 or AA71 & Transition RXMC-CE05 | DNA | DNA | 0.17 [0.042] | 0.18 [0.045] | 0.21 [0.052] | 0.24 [0.060] | 0.27 [0.067] | DNA | DNA | DNA | DNA | DNA | DNA |
| Concentric Diffuser RXRN-AA66 or AA76 & Transition RXMC-CF06 | DNA | DNA | DNA | DNA | DNA | DNA | DNA | DNA | DNA | DNA | DNA | DNA | DNA |
| Economizer | 0.09 [0.022] | 0.10 [0.025] | 0.11 [0.027] | 0.12 [0.030] | 0.13 [0.032] | 0.14 [0.035] | 0.15 [0.037] | 0.16 [0.040] | 0.17 [0.042] | 0.18 [0.045] | 0.19 [0.047] | 0.20 [0.050] | 0.21 [0.052] |
| 100% R.A. Damper Open | 0.05 [0.012] | 0.06 [0.014] | 0.06 [0.015] | 0.07 [0.017] | 0.08 [0.020] | 0.09 [0.021] | 0.09 [0.022] | 0.10 [0.024] | 0.10 [0.025] | 0.11 [0.027] | 0.12 [0.029] | 0.13 [0.031] | 0.14 [0.033] |
| Horizontal Economizer | 0.11 [0.027] | 0.12 [0.030] | 0.13 [0.032] | 0.15 [0.036] | 0.16 [0.040] | 0.18 [0.044] | 0.19 [0.047] | 0.20 [0.050] | 0.21 [0.052] | DNA | DNA | DNA | DNA |
| 100% O.A. Damper Open | 0.11 [0.027] | 0.12 [0.030] | 0.13 [0.032] | 0.15 [0.036] | 0.16 [0.040] | 0.18 [0.044] | 0.19 [0.047] | 0.20 [0.050] | 0.21 [0.052] | DNA | DNA | DNA | DNA |

NOTE: Add component resistance to duct resistance to determine total external static pressure.
 DNA = Data not Available.

AIRFLOW CORRECTION FACTORS 10 TON [35.2 kW]

| ACTUAL—CFM [L/s] | 3200 [1510] | 3400 [1605] | 3600 [1699] | 3800 [1793] | 4000 [1888] | 4200 [1982] | 4400 [2077] | 4600 [2171] | 4800 [2265] |
|------------------|-------------|-------------|-------------|-------------|-------------|-------------|-------------|-------------|-------------|
| TOTAL MBH | 0.96 | 0.97 | 0.98 | 0.99 | 1.00 | 1.01 | 1.02 | 1.03 | 1.04 |
| SENSIBLE MBH | 0.91 | 0.93 | 0.95 | 0.97 | 1.00 | 1.02 | 1.05 | 1.07 | 1.09 |
| POWER kW | 0.98 | 0.98 | 0.99 | 0.99 | 1.00 | 1.00 | 1.01 | 1.01 | 1.01 |

- NOTES: 1. Multiply correction factor times gross performance data.
 2. Resulting sensible capacity cannot exceed total capacity.

[] Designates Metric Conversions



AIRFLOW PERFORMANCE—12.5 TON [44.0 kW]

| Air Flow CFM [L/s] | | External Static Pressure—Inches of Water [kPa] | | | | | | | | | | | | | | | | | | | |
|-----------------------|------|--|------------|------------|------------|------------|------------|------------|------------|------------|------------|------------|------------|------------|------------|------------|------------|------------|------------|------------|------------|
| | | Voltage 208/230, 460, 575 — 3 phase 60 Hz | | | | | | | | | | | | | | | | | | | |
| | | 0.1 [0.02] | 0.2 [0.05] | 0.3 [0.07] | 0.4 [1.10] | 0.5 [1.12] | 0.6 [1.15] | 0.7 [1.17] | 0.8 [1.20] | 0.9 [1.22] | 1.0 [1.25] | 1.1 [1.27] | 1.2 [1.30] | 1.3 [1.32] | 1.4 [1.35] | 1.5 [1.37] | 1.6 [1.40] | 1.7 [1.42] | 1.8 [1.45] | 1.9 [1.47] | 2.0 [1.50] |
| 3800 [1793] | — | — | — | — | — | — | — | — | — | — | — | — | — | — | — | — | — | — | — | — | |
| 4000 [1888] | — | — | — | — | — | — | — | — | — | — | — | — | — | — | — | — | — | — | — | — | |
| 4200 [1982] | — | — | — | — | — | — | — | — | — | — | — | — | — | — | — | — | — | — | — | — | |
| 4400 [2076] | 836 | 2029 | 862 | 2096 | 886 | 2167 | 911 | 2241 | 936 | 2319 | 960 | 2400 | 984 | 2485 | 1008 | 2573 | 1031 | 2664 | 1055 | 2759 | |
| 4600 [2171] | 867 | 2263 | 891 | 2337 | 916 | 2415 | 940 | 2496 | 964 | 2581 | 988 | 2669 | 1012 | 2760 | 1035 | 2855 | 1058 | 2954 | 1081 | 3056 | |
| 4800 [2265] | 897 | 2518 | 922 | 2599 | 946 | 2684 | 970 | 2772 | 993 | 2864 | 1017 | 2959 | 1040 | 3057 | 1063 | 3159 | 1086 | 3265 | 1108 | 3373 | |
| 5000 [2359] | 929 | 2795 | 953 | 2883 | 976 | 2975 | 1000 | 3070 | 1023 | 3168 | 1046 | 3270 | 1069 | 3375 | 1091 | 3484 | 1114 | 3597 | 1136 | 3712 | |
| 5200 [2454] | 961 | 3093 | 984 | 3188 | 1007 | 3286 | 1030 | 3388 | 1053 | 3494 | 1076 | 3603 | 1098 | 3715 | 1120 | 3831 | 1142 | 3950 | 1164 | 4072 | |
| 5400 [2548] | 993 | 3412 | 1016 | 3514 | 1039 | 3619 | 1062 | 3728 | 1084 | 3841 | 1106 | 3956 | 1128 | 4076 | 1150 | 4198 | 1171 | 4324 | 1193 | 4454 | |
| 5600 [2643] | 1026 | 3752 | 1049 | 3861 | 1071 | 3974 | 1093 | 4089 | 1115 | 4209 | 1137 | 4331 | 1159 | 4458 | 1180 | 4587 | 1201 | 4720 | 1222 | 4857 | |
| 5800 [2737] | 1060 | 4114 | 1082 | 4230 | 1104 | 4349 | 1126 | 4472 | 1147 | 4598 | 1169 | 4728 | 1190 | 4861 | 1211 | 4997 | 1232 | 5137 | 1252 | 5281 | |

NOTE: L-Drive left of bold line, M-Drive right of bold line.

| Drive Package | L | | | | | | M | | | | | |
|----------------|--------------|------|-----|-----|-----|-----|--------------|------|------|------|------|------|
| Motor H.P. [W] | 3.0 [2237.1] | | | | | | 5.0 [3728.5] | | | | | |
| Blower Sheave | BK72H | | | | | | BK85H | | | | | |
| Motor Sheave | 1VP-44 | | | | | | 1VP-65 | | | | | |
| Turns Open | 1 | 2 | 3 | 4 | 5 | 6 | 1 | 2 | 3 | 4 | 5 | 6 |
| RPM | 1051 | 1009 | 966 | 920 | 876 | 824 | 1294 | 1256 | 1216 | 1177 | 1136 | 1094 |

NOTES: 1. Factory sheave settings are shown in bold print.

2. Do not set motor sheave below minimum or maximum turns open shown.

3. Re-adjustment of sheave required to achieve rated airflow at AHRI minimum External Static Pressure.

4. Drive data shown is for horizontal airflow with dry coil. Add component resistance (below) to duct resistance to determine total External Static Pressure.

AIRFLOW CORRECTION FACTORS 12.5 TON [44.0 kW]

| | | | | | | | | | | | |
|------------------|-------------|-------------|-------------|-------------|-------------|-------------|-------------|-------------|-------------|-------------|-------------|
| ACTUAL—CFM [L/s] | 3800 [1793] | 4000 [1888] | 4200 [1982] | 4400 [2077] | 4600 [2171] | 4800 [2265] | 5000 [2360] | 5200 [2454] | 5400 [2549] | 5600 [2643] | 5800 [2737] |
| TOTAL MBH | 0.98 | 0.99 | 1.00 | 1.01 | 1.02 | 1.03 | 1.04 | 1.05 | 1.06 | 1.07 | 1.08 |
| SENSIBLE MBH | 0.93 | 0.96 | 1.00 | 1.04 | 1.07 | 1.11 | 1.14 | 1.18 | 1.21 | 1.25 | 1.28 |
| POWER kW | 0.99 | 1.00 | 1.00 | 1.00 | 1.01 | 1.02 | 1.02 | 1.03 | 1.03 | 1.03 | 1.03 |

NOTES: 1. Multiply correction factor times gross performance data.

2. Resulting sensible capacity cannot exceed total capacity.

[] Designates Metric Conversions

COMPONENT AIR RESISTANCE, IWC 12.5 TON [44.0 kW]

| Component | Standard Indoor Airflow—CFM [L/s] | | | | | | | | | | | | Resistance—Inches Water [kPa] | | | | | | | | | | | |
|--|-----------------------------------|-------------|-------------|-------------|-------------|-------------|-------------|-------------|-------------|-------------|-------------|-------------|-------------------------------|-------------|-------------|-------------|-------------|-------------|-------------|-------------|-------------|-------------|-------------|-------------|
| | 3800 [1793] | 4000 [1888] | 4200 [1982] | 4400 [2076] | 4600 [2171] | 4800 [2265] | 5000 [2359] | 5200 [2454] | 5400 [2548] | 5600 [2643] | 5800 [2737] | 3800 [1793] | 4000 [1888] | 4200 [1982] | 4400 [2076] | 4600 [2171] | 4800 [2265] | 5000 [2359] | 5200 [2454] | 5400 [2548] | 5600 [2643] | 5800 [2737] | | |
| | Wet Coil | 0.08 [0.02] | 0.09 [0.02] | 0.09 [0.02] | 0.10 [0.02] | 0.10 [0.02] | 0.11 [0.03] | 0.11 [0.03] | 0.11 [0.03] | 0.12 [0.03] | 0.12 [0.03] | 0.13 [0.03] | 0.12 [0.02] | 0.12 [0.02] | 0.12 [0.02] | 0.13 [0.03] | 0.13 [0.03] | 0.13 [0.03] | 0.14 [0.03] | 0.14 [0.03] | 0.15 [0.03] | 0.15 [0.03] | 0.16 [0.03] | 0.16 [0.03] |
| Downflow Economizer RA Damper Open | 0.12 [0.03] | 0.13 [0.03] | 0.13 [0.03] | 0.14 [0.04] | 0.14 [0.04] | 0.15 [0.04] | 0.15 [0.04] | 0.16 [0.04] | 0.17 [0.04] | 0.17 [0.04] | 0.18 [0.05] | 0.17 [0.02] | 0.17 [0.02] | 0.17 [0.02] | 0.18 [0.03] | 0.18 [0.03] | 0.19 [0.03] | 0.19 [0.03] | 0.20 [0.03] | 0.20 [0.03] | 0.21 [0.03] | 0.21 [0.03] | 0.22 [0.03] | 0.22 [0.03] |
| Horizontal Economizer RA Damper Open | 0.07 [0.02] | 0.07 [0.02] | 0.08 [0.02] | 0.08 [0.02] | 0.08 [0.02] | 0.09 [0.02] | 0.09 [0.02] | 0.10 [0.02] | 0.10 [0.02] | 0.10 [0.02] | 0.11 [0.03] | 0.10 [0.02] | 0.10 [0.02] | 0.10 [0.02] | 0.11 [0.03] | 0.11 [0.03] | 0.11 [0.03] | 0.11 [0.03] | 0.12 [0.03] | 0.12 [0.03] | 0.12 [0.03] | 0.13 [0.03] | 0.13 [0.03] | 0.13 [0.03] |
| Concentric Grill RXRN-AA61 or RXRN-AA71 & Transition RXMC-CE05 | 0.19 [0.05] | 0.21 [0.05] | 0.21 [0.05] | 0.22 [0.05] | 0.22 [0.05] | 0.24 [0.06] | 0.24 [0.06] | 0.24 [0.06] | 0.25 [0.06] | 0.25 [0.06] | 0.26 [0.06] | 0.25 [0.05] | 0.25 [0.05] | 0.25 [0.05] | 0.26 [0.06] | 0.26 [0.06] | 0.27 [0.06] | 0.27 [0.06] | 0.28 [0.06] | 0.28 [0.06] | 0.29 [0.06] | 0.29 [0.06] | 0.30 [0.06] | 0.30 [0.06] |
| Concentric Grill RXRN-AA66 or RXRN-AA76 & Transition RXMC-CF06 | 0.23 [0.06] | 0.25 [0.06] | 0.25 [0.06] | 0.27 [0.07] | 0.27 [0.07] | 0.29 [0.08] | 0.29 [0.08] | 0.30 [0.08] | 0.30 [0.08] | 0.31 [0.08] | 0.32 [0.08] | 0.30 [0.07] | 0.30 [0.07] | 0.30 [0.07] | 0.31 [0.08] | 0.31 [0.08] | 0.32 [0.08] | 0.32 [0.08] | 0.33 [0.08] | 0.33 [0.08] | 0.34 [0.08] | 0.34 [0.08] | 0.35 [0.08] | 0.35 [0.08] |

NOTE: Add component resistance to duct resistance to determine total external static pressure.



| ELECTRICAL DATA – RLNL-C SERIES | | | | | | | | | | |
|---------------------------------|--|-----------|-----------|---------|---------|---------|---------|-----------|-----------|-----------|
| | | C073CL | C073CM | C073DL | C073DM | C073YL | C073YM | C090CL | C090CM | C090CN |
| Unit Information | Unit Operating Voltage Range | 187-253 | 187-253 | 414-506 | 414-506 | 518-632 | 518-632 | 187-253 | 187-253 | 187-253 |
| | Volts | 208/230 | 208/230 | 460 | 460 | 575 | 575 | 208/230 | 208/230 | 208/230 |
| | Minimum Circuit Ampacity | 35/35 | 35/35 | 16 | 16 | 13 | 13 | 43/43 | 43/43 | 48/48 |
| | Minimum Overcurrent Protection Device Size | 40/40 | 40/40 | 20 | 20 | 15 | 15 | 45/45 | 45/45 | 50/50 |
| | Maximum Overcurrent Protection Device Size | 50/50 | 50/50 | 20 | 20 | 15 | 15 | 50/50 | 50/50 | 60/60 |
| Compressor Motor | No. | 1 | 1 | 1 | 1 | 1 | 1 | 2 | 2 | 2 |
| | Volts | 200/240 | 200/240 | 480 | 480 | 600 | 600 | 200/240 | 200/240 | 200/240 |
| | Phase | 3 | 3 | 3 | 3 | 3 | 3 | 3 | 3 | 3 |
| | RPM | 3450 | 3450 | 3450 | 3450 | 3450 | 3450 | 3450 | 3450 | 3450 |
| | HP, Compressor 1 | 6 | 6 | 6 | 6 | 6 | 6 | 3 1/4 | 3 1/4 | 3 1/4 |
| | Amps (RLA), Comp. 1 | 19.6/19.6 | 19.6/19.6 | 8.2 | 8.2 | 6.6 | 6.6 | 13.1/13.1 | 13.1/13.1 | 13.1/13.1 |
| | Amps (LRA), Comp. 1 | 136/136 | 136/136 | 66.1 | 66.1 | 55.3 | 55.5 | 83.1/83.1 | 83.1/83.1 | 83.1/83.1 |
| Condenser Motor | No. | 2 | 2 | 2 | 2 | 2 | 2 | 2 | 2 | 2 |
| | Volts | 208/230 | 208/230 | 460 | 460 | 575 | 575 | 208/230 | 208/230 | 208/230 |
| | Phase | 1 | 1 | 1 | 1 | 1 | 1 | 1 | 1 | 1 |
| | HP | 1/3 | 1/3 | 1/3 | 1/3 | 1/3 | 1/3 | 1/3 | 1/3 | 1/3 |
| | Amps (FLA, each) | 2.4/2.4 | 2.4/2.4 | 1.4 | 1.4 | 1 | 1 | 1.2/1.2 | 1.2/1.2 | 1.2/1.2 |
| | Amps (LRA, each) | 4.7/4.7 | 4.7/4.7 | 2.4 | 2.4 | 1.5 | 1.5 | 4.7/4.7 | 4.7/4.7 | 4.7/4.7 |
| Evaporator Fan | No. | 1 | 1 | 1 | 1 | 1 | 1 | 1 | 1 | 1 |
| | Volts | 208/230 | 208/230 | 460 | 460 | 575 | 575 | 208/230 | 208/230 | 208/230 |
| | Phase | 3 | 3 | 3 | 3 | 3 | 3 | 3 | 3 | 3 |
| | HP | 1 1/2 | 1 1/2 | 1 1/2 | 1 1/2 | 1 1/2 | 1 1/2 | 2 | 2 | 3 |
| | Amps (FLA, each) | 5.6/5.6 | 5.6/5.6 | 2.8 | 2.8 | 1.9 | 1.9 | 1.9 | 1.9 | 13/13 |
| | Amps (LRA, each) | 28.8/28.8 | 28.8/28.8 | 14.4 | 14.4 | 14 | 14 | 56/56 | 56/56 | 74.5/74.5 |



| ELECTRICAL DATA – RLNL-C SERIES | | | | | | | | | | |
|---------------------------------|--|---------|---------|---------|---------|---------|---------|---------|-----------|---------|
| | | C090DL | C090DM | C090DN | C090YL | C090YM | C090YN | C102CL | C102CM | C102DL |
| Unit Information | Unit Operating Voltage Range | 414-506 | 414-506 | 414-506 | 518-632 | 518-632 | 518-632 | 187-253 | 187-253 | 414-506 |
| | Volts | 460 | 460 | 460 | 575 | 575 | 575 | 208/230 | 208/230 | 460 |
| | Minimum Circuit Ampacity | 21 | 21 | 24 | 16 | 16 | 21 | 49/49 | 54/54 | 23 |
| | Minimum Overcurrent Protection Device Size | 25 | 25 | 25 | 20 | 20 | 25 | 50/50 | 55/55 | 25 |
| | Maximum Overcurrent Protection Device Size | 25 | 25 | 30 | 20 | 20 | 25 | 60/60 | 60/60 | 25 |
| Compressor Motor | No. | 2 | 2 | 2 | 2 | 2 | 2 | 2 | 2 | 2 |
| | Volts | 480 | 480 | 480 | 600 | 600 | 600 | 200/230 | 200/230 | 460 |
| | Phase | 3 | 3 | 3 | 3 | 3 | 3 | 3 | 3 | 3 |
| | RPM | 3450 | 3450 | 3450 | 3450 | 3450 | 3450 | 3450 | 3450 | 3450 |
| | HP, Compressor 1 | 3 1/4 | 3 1/4 | 3 1/4 | 3 1/4 | 3 1/4 | 3 1/4 | 3 3/4 | 3 3/4 | 3 3/4 |
| | Amps (RLA), Comp. 1 | 6.1 | 6.1 | 6.1 | 4.4 | 4.4 | 4.4 | 16/16 | 16/16 | 7.1 |
| | Amps (LRA), Comp. 1 | 41 | 41 | 41 | 33 | 33 | 33 | 91/91 | 91/91 | 46 |
| | HP, Compressor 2 | 3 1/4 | 3 1/4 | 3 1/4 | 3 1/4 | 3 1/4 | 3 1/4 | 3 3/4 | 3 3/4 | 3 3/4 |
| | Amps (RLA), Comp. 2 | 6.1 | 6.1 | 6.1 | 4.4 | 4.4 | 4.4 | 16/16 | 16/16 | 7.1 |
| | Amps (LRA), Comp. 2 | 41 | 41 | 41 | 33 | 33 | 33 | 91/91 | 91/91 | 46 |
| Condenser Motor | No. | 2 | 2 | 2 | 2 | 2 | 2 | 2 | 2 | 2 |
| | Volts | 460 | 460 | 460 | 575 | 575 | 575 | 208/230 | 208/230 | 460 |
| | Phase | 1 | 1 | 1 | 1 | 1 | 1 | 1 | 1 | 1 |
| | HP | 1/3 | 1/3 | 1/3 | 1/3 | 1/3 | 1/3 | 1/3 | 1/3 | 1/3 |
| | Amps (FLA, each) | 1.4 | 1.4 | 1.4 | 1 | 1 | 1 | 2.4/2.4 | 2.4/2.4 | 1.4 |
| | Amps (LRA, each) | 2.4 | 2.4 | 2.4 | 1.5 | 1.5 | 1.5 | 4.7/4.7 | 4.7/4.7 | 2.4 |
| Evaporator Fan | No. | 1 | 1 | 1 | 1 | 1 | 1 | 1 | 1 | 1 |
| | Volts | 460 | 460 | 460 | 575 | 575 | 575 | 208/230 | 208/230 | 460 |
| | Phase | 3 | 3 | 3 | 3 | 3 | 3 | 3 | 3 | 3 |
| | HP | 2 | 2 | 3 | 2 | 2 | 3 | 2 | 3 | 2 |
| | Amps (FLA, each) | 4 | 4 | 7 | 4 | 4 | 8 | 8/8 | 13/13 | 4 |
| | Amps (LRA, each) | 28 | 28 | 38.1 | 19 | 19 | 20 | 56/56 | 74.5/74.5 | 28 |



| ELECTRICAL DATA – RLNL-C SERIES | | | | | | | | | | |
|--|--|---------------|---------------|---------------|---------------|---------------|---------------|---------------|---------------|---------------|
| | | C102DM | C102YL | C102YM | C120CL | C120CM | C120DL | C120DM | C120YL | C120YM |
| Unit Information | Unit Operating Voltage Range | 414-506 | 518-632 | 518-632 | 187-253 | 187-253 | 414-506 | 414-506 | 518-632 | 518-632 |
| | Volts | 460 | 575 | 575 | 208/230 | 208/230 | 460 | 460 | 575 | 575 |
| | Minimum Circuit Ampacity | 26 | 19 | 24 | 49/49 | 54/54 | 25 | 28 | 19 | 24 |
| | Minimum Overcurrent Protection Device Size | 30 | 20 | 25 | 50/50 | 55/55 | 25 | 30 | 20 | 25 |
| | Maximum Overcurrent Protection Device Size | 30 | 20 | 30 | 60/60 | 60/60 | 30 | 35 | 20 | 30 |
| Compressor Motor | No. | 2 | 2 | 2 | 2 | 2 | 2 | 2 | 2 | 2 |
| | Volts | 460 | 575 | 575 | 200/240 | 200/240 | 480 | 480 | 575 | 575 |
| | Phase | 3 | 3 | 3 | 3 | 3 | 3 | 3 | 3 | 3 |
| | RPM | 3450 | 3450 | 3450 | 3450 | 3450 | 3450 | 3450 | 3450 | 3450 |
| | HP, Compressor 1 | 3 3/4 | 3 3/4 | 3 3/4 | 4 1/4 | 4 1/4 | 4 1/4 | 4 1/4 | 4 1/4 | 4 1/4 |
| | Amps (RLA), Comp. 1 | 7.1 | 5.6 | 5.6 | 16/16 | 16/16 | 7.8 | 7.8 | 5.7 | 5.7 |
| | Amps (LRA), Comp. 1 | 46 | 37 | 37 | 110/110 | 110/110 | 52 | 52 | 38.9 | 38.9 |
| | HP, Compressor 2 | 3 3/4 | 3 3/4 | 3 3/4 | 4 1/4 | 4 1/4 | 4 1/4 | 4 1/4 | 4 1/4 | 4 1/4 |
| | Amps (RLA), Comp. 2 | 7.1 | 5.6 | 5.6 | 16/16 | 16/16 | 7.8 | 7.8 | 5.7 | 5.7 |
| Amps (LRA), Comp. 2 | 46 | 37 | 37 | 110/110 | 110/110 | 52 | 52 | 38.9 | 38.9 | |
| Condenser Motor | No. | 2 | 2 | 2 | 2 | 2 | 2 | 2 | 2 | 2 |
| | Volts | 460 | 575 | 575 | 208/230 | 208/230 | 460 | 460 | 575 | 575 |
| | Phase | 1 | 1 | 1 | 1 | 1 | 1 | 1 | 1 | 1 |
| | HP | 1/3 | 1/3 | 1/3 | 1/3 | 1/3 | 1/3 | 1/3 | 1/3 | 1/3 |
| | Amps (FLA, each) | 1.4 | 1 | 1 | 2.4/2.4 | 2.4/2.4 | 1.4 | 1.4 | 1 | 1 |
| | Amps (LRA, each) | 2.4 | 1.5 | 1.5 | 4.7/4.7 | 4.7/4.7 | 2.4 | 2.4 | 1.5 | 1.5 |
| Evaporator Fan | No. | 1 | 1 | 1 | 1 | 1 | 1 | 1 | 1 | 1 |
| | Volts | 460 | 575 | 575 | 208/230 | 208/230 | 460 | 460 | 575 | 575 |
| | Phase | 3 | 3 | 3 | 3 | 3 | 3 | 3 | 3 | 3 |
| | HP | 3 | 2 | 3 | 2 | 3 | 2 | 3 | 2 | 3 |
| | Amps (FLA, each) | 7 | 4 | 8 | 8/8 | 13/13 | 4 | 7 | 4 | 8 |
| | Amps (LRA, each) | 38.1 | 19 | 20 | 56/56 | 74.5/74.5 | 28 | 38.1 | 19 | 20 |



| ELECTRICAL DATA – RLNL-C SERIES | | | | | | | |
|---------------------------------|--|-----------|-----------|---------|---------|---------|---------|
| | | C151CL | C151CM | C151DL | C151DM | C151YL | C151YM |
| Unit Information | Unit Operating Voltage Range | 187-253 | 187-253 | 414-506 | 414-506 | 518-632 | 518-632 |
| | Volts | 208/230 | 208/230 | 460 | 460 | 575 | 575 |
| | Minimum Circuit Ampacity | 67/67 | 71/71 | 33 | 36 | 28 | 28 |
| | Minimum Overcurrent Protection Device Size | 70/70 | 75/75 | 35 | 40 | 30 | 30 |
| | Maximum Overcurrent Protection Device Size | 80/80 | 90/90 | 40 | 45 | 35 | 35 |
| Compressor Motor | No. | 2 | 2 | 2 | 2 | 2 | 2 |
| | Volts | 208/230 | 208/230 | 460 | 460 | 575 | 575 |
| | Phase | 3 | 3 | 3 | 3 | 3 | 3 |
| | RPM | 3450 | 3450 | 3450 | 3450 | 3450 | 3450 |
| | HP, Compressor 1 | 5 3/4 | 5 3/4 | 5 3/4 | 5 3/4 | 5 3/4 | 5 3/4 |
| | Amps (RLA), Comp. 1 | 22.4/22.4 | 22.4/22.4 | 10.6 | 10.6 | 7.7 | 7.7 |
| | Amps (LRA), Comp. 1 | 149/149 | 149/149 | 75 | 75 | 54 | 54 |
| | HP, Compressor 2 | 5 1/4 | 5 1/4 | 5 1/4 | 5 1/4 | 5 1/4 | 5 1/4 |
| | Amps (RLA), Comp. 2 | 19/19 | 19/19 | 9.7 | 9.7 | 7.4 | 7.4 |
| Amps (LRA), Comp. 2 | 123/123 | 123/123 | 62 | 62 | 50 | 50 | |
| Condenser Motor | No. | 2 | 2 | 2 | 2 | 2 | 2 |
| | Volts | 208/230 | 208/230 | 460 | 460 | 575 | 575 |
| | Phase | 1 | 1 | 1 | 1 | 1 | 1 |
| | HP | 1/2 | 1/2 | 1/2 | 1/2 | 1/2 | 1/2 |
| | Amps (FLA, each) | 2.3/2.3 | 2.3/2.3 | 1.5 | 1.5 | 1 | 1 |
| | Amps (LRA, each) | 5.6/5.6 | 5.6/5.6 | 3.1 | 3.1 | 2.2 | 2.2 |
| Evaporator Fan | No. | 1 | 1 | 1 | 1 | 1 | 1 |
| | Volts | 208/230 | 208/230 | 460 | 460 | 575 | 575 |
| | Phase | 3 | 3 | 3 | 3 | 3 | 3 |
| | HP | 3 | 5 | 3 | 5 | 3 | 5 |
| | Amps (FLA, each) | 15/15 | 18.8/18.8 | 7 | 10 | 8 | 8 |
| | Amps (LRA, each) | 74.5/74.5 | 82.6/82.6 | 38.1 | 41.3 | 20 | 33 |

| 208/240 VOLT, THREE PHASE, 60 HZ, AUXILIARY ELECTRIC HEATER KITS CHARACTERISTICS AND APPLICATION | | | | | | | | | | | | | | |
|--|-----------------------------|-----------------------|-----------------------------|----------------------------|-------------------------|--------------------------------|---|---|------------------------------|--------------------------|--|---|---|--|
| Single Power Supply For Both Unit and Heater Kit | | | | | | | | | | | | | | |
| Unit Model No. RLNL- | Heater Kit | | | | | Air Conditioner | | | | | Separate Power Supply For Both Unit and Heater Kit | | | |
| | RXJJ- Heater Kit Nominal kW | No. of Sequence Steps | Rated Heater kW @ 208/240 V | Heater KBTU/Hr @ 208/240 V | Heater Amp. @ 208/240 V | Unit Min. Ampacity @ 208/240 V | Over Current Protective Device Size Min./Max. @ 208 V | Over Current Protective Device Size Min./Max. @ 240 V | Min. Ckt. Ampacity 208/240 V | Max. Fuse Size 208/240 V | Min. Circuit Ampacity 208/240 V | Over Current Protective Device Size Min./Max. @ 208 V | Over Current Protective Device Size Min./Max. @ 240 V | |
| C073CL | No Heat | — | — | — | — | 35/35 | 40/50 | 40/50 | — | — | 35/35 | 40/50 | 40/50 | |
| | CC10C | 1 | 7.2/9.6 | 24.56/32.75 | 20/23.1 | 35/36 | 45/50 | 45/50 | 25/29 | 25/30 | — | — | — | |
| | CC15C | 1 | 10.8/14.4 | 36.84/49.13 | 30/34.6 | 45/51 | 45/50 | 60/60 | 38/44 | 40/45 | — | — | — | |
| | CC20C | 1 | 14.4/19.2 | 49.13/65.5 | 40/46.2 | 57/65 | 60/60 | 70/70 | 50/58 | 50/60 | — | — | — | |
| | CC30C | 1 | 21.6/28.8 | 73.69/98.25 | 60/69.3 | 82/94 | 90/90 | 100/100 | 75/87 | 80/90 | — | — | — | |
| C090CL | No Heat | — | — | — | — | 43/43 | 45/50 | 45/50 | — | — | 43/43 | 45/50 | 45/50 | |
| | CC10C | 1 | 7.2/9.6 | 24.56/32.75 | 20/23.1 | 43/43 | 50/50 | 50/50 | 25/29 | 25/30 | — | — | — | |
| | CC15C | 1 | 10.8/14.4 | 36.84/49.13 | 30/34.6 | 48/54 | 50/50 | 60/60 | 38/44 | 40/45 | — | — | — | |
| | CC20C | 1 | 14.4/19.2 | 49.13/65.5 | 40/46.2 | 60/68 | 60/60 | 70/70 | 50/58 | 50/60 | — | — | — | |
| | CC30C | 1 | 21.6/28.8 | 73.69/98.25 | 60/69.3 | 85/97 | 90/90 | 100/100 | 75/87 | 80/90 | — | — | — | |
| C102CL | No Heat | — | — | — | — | 111/126 | 125/125 | 150/150 | 101/116 | 110/125 | — | — | — | |
| | CC10C | 1 | 7.2/9.6 | 24.56/32.75 | 20/23.1 | 49/49 | 50/60 | 50/60 | — | — | 49/49 | 50/60 | 50/60 | |
| | CC15C | 1 | 10.8/14.4 | 36.84/49.13 | 30/34.6 | 49/54 | 60/60 | 60/60 | 25/29 | 25/30 | — | — | — | |
| | CC20C | 1 | 14.4/19.2 | 49.13/65.5 | 40/46.2 | 60/68 | 60/60 | 70/70 | 38/44 | 40/45 | — | — | — | |
| | CC30C | 1 | 21.6/28.8 | 73.69/98.25 | 60/69.3 | 85/97 | 90/90 | 100/100 | 50/58 | 50/60 | — | — | — | |
| C120CL | No Heat | — | — | — | — | 111/126 | 125/125 | 150/150 | 101/116 | 110/125 | — | — | — | |
| | CC10C | 1 | 7.2/9.6 | 24.56/32.75 | 20/23.1 | 49/49 | 50/60 | 50/60 | — | — | 49/49 | 50/60 | 50/60 | |
| | CC15C | 1 | 10.8/14.4 | 36.84/49.13 | 30/34.6 | 49/54 | 60/60 | 60/60 | 25/29 | 25/30 | — | — | — | |
| | CC20C | 1 | 14.4/19.2 | 49.13/65.5 | 40/46.2 | 60/68 | 60/60 | 70/70 | 38/44 | 40/45 | — | — | — | |
| | CC30C | 1 | 21.6/28.8 | 73.69/98.25 | 60/69.3 | 85/97 | 90/90 | 100/100 | 50/58 | 50/60 | — | — | — | |
| C151CL | No Heat | — | — | — | — | 136/155 | 150/150 | 175/175 | 126/145 | 150/150 | — | — | — | |
| | CC10C | 1 | 36.1/48 | 123.16/163.75 | 100.1/115.5 | 136/155 | 150/150 | 175/175 | 67/67 | 70/80 | 67/67 | 70/80 | 70/80 | |
| | CC15C | 1 | 7.2/9.6 | 24.56/32.75 | 20/23.1 | 67/67 | 80/80 | 80/80 | 25/29 | 25/30 | — | — | — | |
| | CC20C | 1 | 10.8/14.4 | 36.84/49.13 | 30/34.6 | 67/67 | 80/80 | 80/80 | 38/44 | 40/45 | — | — | — | |
| | CC30C | 1 | 14.4/19.2 | 49.13/65.5 | 40/46.2 | 69/77 | 80/80 | 80/80 | 50/58 | 50/60 | — | — | — | |
| C151CL | No Heat | — | — | — | — | 144/164 | 150/150 | 175/175 | 126/145 | 150/150 | — | — | — | |
| | CC10C | 1 | 36.1/48 | 123.16/163.75 | 100.1/115.5 | 144/164 | 150/150 | 175/175 | 101/116 | 110/125 | — | — | — | |
| | CC15C | 1 | 7.2/9.6 | 24.56/32.75 | 20/23.1 | 119/135 | 125/125 | 150/150 | 75/87 | 80/90 | — | — | — | |
| | CC20C | 1 | 10.8/14.4 | 36.84/49.13 | 30/34.6 | 119/135 | 125/125 | 150/150 | 101/116 | 110/125 | — | — | — | |
| | CC30C | 1 | 14.4/19.2 | 49.13/65.5 | 40/46.2 | 144/164 | 150/150 | 175/175 | 126/145 | 150/150 | — | — | — | |

*= For Canadian use only. Uses "P" fuses for inductive circuit.
+ = Field installed only.

UNITS WITH HEATER KITS—RLNL-C SERIES



| 208/240 VOLT, THREE PHASE, 60 HZ, AUXILIARY ELECTRIC HEATER KITS CHARACTERISTICS AND APPLICATION | | | | | | | | | | | | | | | |
|--|-----------------------------|-----------------------|-----------------------------|----------------------------|-------------------------|--------------------------------|-------------------------------------|---------|-------------------------------------|---------|------------------------------|--------------------------|---------------------------------|-------------------|-------------------|
| Single Power Supply For Both Unit and Heater Kit | | | | | | | | | | | | | | | |
| Unit Model No. RLNL- | Heater Kit | | | | | Air Conditioner | | | | | Heater Kit | | | Air Conditioner | |
| | RXJJ- Heater Kit Nominal kW | No. of Sequence Steps | Rated Heater kW @ 208/240 V | Heater KBTU/HR @ 208/240 V | Heater Amp. @ 208/240 V | Unit Min. Ampacity @ 208/240 V | Over Current Protective Device Size | | Over Current Protective Device Size | | Min. Ckt. Ampacity 208/240 V | Max. Fuse Size 208/240 V | Min. Circuit Ampacity 208/240 V | Min./Max. @ 208 V | Min./Max. @ 240 V |
| C073CM | No Heat | — | — | — | — | 35/35 | 40/50 | 40/50 | — | — | — | — | 35/35 | 40/50 | 40/50 |
| | CC10C | 1 | 7.2/9.6 | 24.56/32.75 | 20/23.1 | 35/36 | 45/50 | 45/50 | 25/29 | 25/30 | — | — | — | — | — |
| | CC15C | 1 | 10.8/14.4 | 36.84/49.13 | 30/34.6 | 45/51 | 45/50 | 60/60 | 38/44 | 40/45 | — | — | — | — | — |
| | CC20C | 1 | 14.4/19.2 | 49.13/65.5 | 40/46.2 | 57/65 | 60/60 | 70/70 | 50/58 | 50/60 | — | — | — | — | — |
| | CC30C | 1 | 21.6/28.8 | 73.69/98.25 | 60/69.3 | 82/94 | 90/90 | 100/100 | 75/87 | 80/90 | — | — | — | — | — |
| C090CM | No Heat | — | — | — | — | 43/43 | 45/50 | 45/50 | — | — | — | — | 43/43 | 45/50 | 45/50 |
| | CC10C | 1 | 7.2/9.6 | 24.56/32.75 | 20/23.1 | 43/43 | 50/50 | 50/50 | 25/29 | 25/30 | — | — | — | — | — |
| | CC15C | 1 | 10.8/14.4 | 36.84/49.13 | 30/34.6 | 48/54 | 50/50 | 60/60 | 38/44 | 40/45 | — | — | — | — | — |
| | CC20C | 1 | 14.4/19.2 | 49.13/65.5 | 40/46.2 | 60/68 | 60/60 | 70/70 | 50/58 | 50/60 | — | — | — | — | — |
| | CC30C | 1 | 21.6/28.8 | 73.69/98.25 | 60/69.3 | 85/97 | 90/90 | 100/100 | 75/87 | 80/90 | — | — | — | — | — |
| C102CM | No Heat | — | — | — | — | 111/126 | 125/125 | 150/150 | 101/116 | 110/125 | — | — | — | — | — |
| | CC10C | 1 | 7.2/9.6 | 24.56/32.75 | 20/23.1 | 54/54 | 55/60 | 60/60 | 25/29 | 25/30 | — | — | 54/54 | 55/60 | 55/60 |
| | CC15C | 1 | 10.8/14.4 | 36.84/49.13 | 30/34.6 | 54/60 | 60/60 | 60/60 | 38/44 | 40/45 | — | — | — | — | — |
| | CC20C | 1 | 14.4/19.2 | 49.13/65.5 | 40/46.2 | 67/75 | 70/70 | 80/80 | 50/58 | 50/60 | — | — | — | — | — |
| | CC30C | 1 | 21.6/28.8 | 73.69/98.25 | 60/69.3 | 92/103 | 100/100 | 110/110 | 75/87 | 80/90 | — | — | — | — | — |
| C120CM | No Heat | — | — | — | — | 117/132 | 125/125 | 150/150 | 101/116 | 110/125 | — | — | — | — | — |
| | CC10C | 1 | 7.2/9.6 | 24.56/32.75 | 20/23.1 | 54/54 | 55/60 | 60/60 | 25/29 | 25/30 | — | — | 54/54 | 55/60 | 55/60 |
| | CC15C | 1 | 10.8/14.4 | 36.84/49.13 | 30/34.6 | 54/60 | 60/60 | 60/60 | 38/44 | 40/45 | — | — | — | — | — |
| | CC20C | 1 | 14.4/19.2 | 49.13/65.5 | 40/46.2 | 67/75 | 70/70 | 80/80 | 50/58 | 50/60 | — | — | — | — | — |
| | CC30C | 1 | 21.6/28.8 | 73.69/98.25 | 60/69.3 | 92/103 | 100/100 | 110/110 | 75/87 | 80/90 | — | — | — | — | — |
| C151CM | No Heat | — | — | — | — | 142/161 | 150/150 | 175/175 | 126/145 | 150/150 | — | — | — | — | — |
| | CC10C | 1 | 7.2/9.6 | 24.56/32.75 | 20/23.1 | 54/54 | 55/60 | 60/60 | 25/29 | 25/30 | — | — | 54/54 | 55/60 | 55/60 |
| | CC15C | 1 | 10.8/14.4 | 36.84/49.13 | 30/34.6 | 54/60 | 60/60 | 60/60 | 38/44 | 40/45 | — | — | — | — | — |
| | CC20C | 1 | 14.4/19.2 | 49.13/65.5 | 40/46.2 | 67/75 | 70/70 | 80/80 | 50/58 | 50/60 | — | — | — | — | — |
| | CC30C | 1 | 21.6/28.8 | 73.69/98.25 | 60/69.3 | 92/103 | 100/100 | 110/110 | 75/87 | 80/90 | — | — | — | — | — |

*= For Canadian use only. Uses "pr" fuses for inductive circuit.
 += Field installed only.

480 VOLT, THREE PHASE, 60 HZ, AUXILIARY ELECTRIC HEATER KITS CHARACTERISTICS AND APPLICATION

| Single Power Supply For Both Unit and Heater Kit | | | | | | | | | | Separate Power Supply For Both Unit and Heater Kit | | | | | |
|--|----------------------------|-----------------------|-------------------------|------------------------|---------------------|---------------------------------|---|---|--------------------------|--|--------------------------|---|---|-----------------|--|
| Unit Model No. RLNL- | Heater Kit | | | | | Air Conditioner | | | | | Heater Kit | | | Air Conditioner | |
| | RXJJ-Heater Kit Nominal kW | No. of Sequence Steps | Rated Heater kW @ 480 V | Heater KBTU/Hr @ 480 V | Heater Amp. @ 480 V | Unit Min. Ckt. Ampacity @ 480 V | Over Current Protective Device Size Min./Max. @ 480 V | Over Current Protective Device Size Min./Max. @ 480 V | Min. Ckt. Ampacity 480 V | Max. Fuse Size 480 V | Min. Ckt. Ampacity 480 V | Over Current Protective Device Size Min./Max. @ 480 V | Over Current Protective Device Size Min./Max. @ 480 V | | |
| C073DL | No Heat | — | — | — | — | 16 | 20/20 | — | 16 | — | 16 | 20/20 | — | | |
| | CC10D | 1 | 9.6 | 32.75 | 11.5 | 18 | 20/20 | — | 15 | 15 | — | — | — | | |
| | CC15D | 1 | 14.4 | 49.13 | 17.3 | 26 | 30/30 | — | 22 | 25 | — | — | — | | |
| | CC20D | 1 | 19.2 | 65.5 | 23.1 | 33 | 35/35 | — | 29 | 30 | — | — | — | | |
| | CC30D | 1 | 28.8 | 98.25 | 34.6 | 47 | 50/50 | — | 44 | 45 | — | — | — | | |
| C090DL | No Heat | — | — | — | — | 21 | 25/25 | — | 21 | — | 21 | 25/25 | — | | |
| | CC10D | 1 | 9.6 | 32.75 | 11.5 | 21 | 25/25 | — | 15 | 15 | — | — | — | | |
| | CC15D | 1 | 14.4 | 49.13 | 17.3 | 27 | 30/30 | — | 22 | 25 | — | — | — | | |
| | CC20D | 1 | 19.2 | 65.5 | 23.1 | 34 | 35/35 | — | 29 | 30 | — | — | — | | |
| | CC30D | 1 | 28.8 | 98.25 | 34.6 | 49 | 50/50 | — | 44 | 45 | — | — | — | | |
| C102DL | No Heat | — | — | — | — | 63 | 70/70 | — | 58 | 60 | — | — | — | | |
| | CC10D | 1 | 9.6 | 32.75 | 11.5 | 23 | 25/25 | — | 15 | 15 | — | — | — | | |
| | CC15D | 1 | 14.4 | 49.13 | 17.3 | 27 | 30/30 | — | 22 | 25 | — | — | — | | |
| | CC20D | 1 | 19.2 | 65.5 | 23.1 | 34 | 35/35 | — | 29 | 30 | — | — | — | | |
| | CC30D | 1 | 28.8 | 98.25 | 34.6 | 49 | 50/50 | — | 44 | 45 | — | — | — | | |
| C120DL | No Heat | — | — | — | — | 63 | 70/70 | — | 58 | 60 | — | — | — | | |
| | CC10D | 1 | 9.6 | 32.75 | 11.5 | 25 | 25/30 | — | 15 | 15 | — | — | — | | |
| | CC15D | 1 | 14.4 | 49.13 | 17.3 | 27 | 30/30 | — | 22 | 25 | — | — | — | | |
| | CC20D | 1 | 19.2 | 65.5 | 23.1 | 34 | 35/35 | — | 29 | 30 | — | — | — | | |
| | CC30D | 1 | 28.8 | 98.25 | 34.6 | 49 | 50/50 | — | 44 | 45 | — | — | — | | |
| C151DL | No Heat | — | — | — | — | 78 | 80/80 | — | 73 | 80 | — | — | — | | |
| | CC10D | 1 | 9.6 | 32.75 | 11.5 | 25 | 30/30 | — | 15 | 15 | — | — | — | | |
| | CC15D | 1 | 14.4 | 49.13 | 17.3 | 27 | 30/30 | — | 22 | 25 | — | — | — | | |
| | CC20D | 1 | 19.2 | 65.5 | 23.1 | 33 | 35/40 | — | 29 | 30 | — | — | — | | |
| | CC30D | 1 | 28.8 | 98.25 | 34.6 | 52 | 60/60 | — | 44 | 45 | — | — | — | | |
| C151DL | No Heat | — | — | — | — | 81 | 90/90 | — | 73 | 80 | — | — | — | | |
| | CC10D | 1 | 9.6 | 32.75 | 11.5 | 33 | 40/40 | — | 15 | 15 | — | — | — | | |
| | CC15D | 1 | 14.4 | 49.13 | 17.3 | 33 | 40/40 | — | 22 | 25 | — | — | — | | |
| | CC20D | 1 | 19.2 | 65.5 | 23.1 | 38 | 40/40 | — | 29 | 30 | — | — | — | | |
| | CC30D | 1 | 28.8 | 98.25 | 34.6 | 52 | 60/60 | — | 44 | 45 | — | — | — | | |
| C151DL | No Heat | — | — | — | — | 67 | 70/70 | — | 58 | 60 | — | — | — | | |
| | CC10D | 1 | 9.6 | 32.75 | 11.5 | 67 | 70/70 | — | 58 | 60 | — | — | — | | |
| | CC15D | 1 | 14.4 | 49.13 | 17.3 | 67 | 70/70 | — | 58 | 60 | — | — | — | | |
| | CC20D | 1 | 19.2 | 65.5 | 23.1 | 67 | 70/70 | — | 58 | 60 | — | — | — | | |
| | CC30D | 1 | 28.8 | 98.25 | 34.6 | 67 | 70/70 | — | 58 | 60 | — | — | — | | |

*= For Canadian use only. Uses "P" fuses for inductive circuit.
+ = Field installed only.

UNITS WITH HEATER KITS—RLNL-C SERIES



| 480 VOLT, THREE PHASE, 60 HZ, AUXILIARY ELECTRIC HEATER KITS CHARACTERISTICS AND APPLICATION | | | | | | | | | | | | |
|--|--|-------------------------|------------------------|---------------------|----------------------------|---|--|----------------------|-----------------------------|---|-------------------|-------------------|
| Separate Power Supply For Both Unit and Heater Kit | | | | | | | | | | | | |
| Unit Model No. RLNL- | Single Power Supply For Both Unit and Heater Kit | | | | | | Separate Power Supply For Both Unit and Heater Kit | | | | | |
| | Heater Kit | | | Air Conditioner | | | Heater Kit | | | Air Conditioner | | |
| RXJJ- Heater Kit Nominal kW | No. of Sequence Steps | Rated Heater kW @ 480 V | Heater KBTU/Hr @ 480 V | Heater Amp. @ 480 V | Unit Min. Ampacity @ 480 V | Over Current Protective Device Size Min./Max. @ 480 V | Min. Ckt. Ampacity 480 V | Max. Fuse Size 480 V | Min. Circuit Ampacity 480 V | Over Current Protective Device Size Min./Max. @ 480 V | Min./Max. @ 480 V | Min./Max. @ 480 V |
| No Heat | — | — | — | — | 16 | 20/20 | — | — | 16 | 20/20 | — | — |
| CC10D | 1 | 9.6 | 32.75 | 11.5 | 18 | 20/20 | — | 15 | — | — | — | — |
| CC15D | 1 | 14.4 | 49.13 | 17.3 | 26 | 30/30 | — | 25 | — | — | — | — |
| CC20D | 1 | 19.2 | 65.5 | 23.1 | 33 | 35/35 | — | 30 | — | — | — | — |
| CC30D | 1 | 28.8 | 98.25 | 34.6 | 47 | 50/50 | — | 45 | — | — | — | — |
| No Heat | — | — | — | — | 21 | 25/25 | — | — | 21 | 25/25 | — | — |
| CC10D | 1 | 9.6 | 32.75 | 11.5 | 21 | 25/25 | — | 15 | — | — | — | — |
| CC15D | 1 | 14.4 | 49.13 | 17.3 | 27 | 30/30 | — | 25 | — | — | — | — |
| CC20D | 1 | 19.2 | 65.5 | 23.1 | 34 | 35/35 | — | 30 | — | — | — | — |
| CC30D | 1 | 28.8 | 98.25 | 34.6 | 49 | 50/50 | — | 45 | — | — | — | — |
| CC40D | 1 | 38.4 | 131 | 46.2 | 63 | 70/70 | — | 60 | — | — | — | — |
| No Heat | — | — | — | — | 26 | 30/30 | — | — | 26 | 30/30 | — | — |
| CC10D | 1 | 9.6 | 32.75 | 11.5 | 26 | 30/30 | — | 15 | — | — | — | — |
| CC15D | 1 | 14.4 | 49.13 | 17.3 | 31 | 35/35 | — | 25 | — | — | — | — |
| CC20D | 1 | 19.2 | 65.5 | 23.1 | 38 | 40/40 | — | 30 | — | — | — | — |
| CC30D | 1 | 28.8 | 98.25 | 34.6 | 52 | 60/60 | — | 45 | — | — | — | — |
| CC40D | 1 | 38.4 | 131 | 46.2 | 67 | 70/70 | — | 60 | — | — | — | — |
| No Heat | — | — | — | — | 28 | 30/35 | — | — | 28 | 30/35 | — | — |
| CC10D | 1 | 9.6 | 32.75 | 11.5 | 28 | 30/35 | — | 15 | — | — | — | — |
| CC15D | 1 | 14.4 | 49.13 | 17.3 | 31 | 35/35 | — | 25 | — | — | — | — |
| CC20D | 1 | 19.2 | 65.5 | 23.1 | 38 | 40/40 | — | 30 | — | — | — | — |
| CC30D | 1 | 28.8 | 98.25 | 34.6 | 52 | 60/60 | — | 45 | — | — | — | — |
| CC40D | 1 | 38.4 | 131 | 46.2 | 67 | 70/70 | — | 60 | — | — | — | — |
| CC50D | 1 | 48 | 163.75 | 57.7 | 81 | 90/90 | — | 80 | — | — | — | — |
| No Heat | — | — | — | — | 36 | 40/45 | — | — | 36 | 40/45 | — | — |
| CC10D | 1 | 9.6 | 32.75 | 11.5 | 36 | 40/45 | — | 15 | — | — | — | — |
| CC15D | 1 | 14.4 | 49.13 | 17.3 | 36 | 40/45 | — | 25 | — | — | — | — |
| CC20D | 1 | 19.2 | 65.5 | 23.1 | 42 | 45/45 | — | 30 | — | — | — | — |
| CC30D | 1 | 28.8 | 98.25 | 34.6 | 56 | 60/60 | — | 45 | — | — | — | — |
| CC40D | 1 | 38.4 | 131 | 46.2 | 71 | 80/80 | — | 60 | — | — | — | — |
| CC50D | 1 | 48 | 163.75 | 57.7 | 85 | 90/90 | — | 80 | — | — | — | — |

*= For Canadian use only. Uses "Pr" fuses for inductive circuit.
 += Field installed only.



| 600 VOLT, THREE PHASE, 60 HZ, AUXILIARY ELECTRIC HEATER KITS CHARACTERISTICS AND APPLICATION | | | | | | | | | | | | |
|--|----------------------------|-----------------------|-------------------------|------------------------|---------------------|---------------------------------|---|--------------------------|--|-----------------------------|---|---|
| Single Power Supply For Both Unit and Heater Kit | | | | | | | | | | | | |
| Unit Model No. RLNL- | Heater Kit | | | | | Air Conditioner | | | Separate Power Supply For Both Unit and Heater Kit | | | |
| | RXJJ-Heater Kit Nominal kW | No. of Sequence Steps | Rated Heater kW @ 600 V | Heater KBTU/Hr @ 600 V | Heater Amp. @ 600 V | Unit Min. Ckt. Ampacity @ 600 V | Over Current Protective Device Size Min./Max. @ 600 V | Min. Ckt. Ampacity 600 V | Max. Fuse Size 600 V | Min. Circuit Ampacity 600 V | Over Current Protective Device Size Min./Max. @ 600 V | Over Current Protective Device Size Min./Max. @ 600 V |
| C073YL | No Heat | — | — | — | — | 13 | 15/15 | — | — | 13 | 15/15 | — |
| | CC10Y | 1 | 9.6 | 32.75 | 9.2 | 14 | 15/15 | — | 15 | — | — | — |
| | CC15Y | 1 | 14.4 | 49.13 | 13.9 | 20 | 20/20 | — | 20 | — | — | — |
| | CC20Y | 1 | 19.2 | 65.5 | 18.5 | 26 | 30/30 | — | 25 | — | — | — |
| | CC30Y | 1 | 28.8 | 98.25 | 27.7 | 38 | 40/40 | — | 35 | — | — | — |
| C090YL | No Heat | — | — | — | — | 16 | 20/20 | — | — | 16 | 20/20 | — |
| | CC10Y | 1 | 9.6 | 32.75 | 9.2 | 17 | 20/20 | — | 15 | — | — | — |
| | CC15Y | 1 | 14.4 | 49.13 | 13.9 | 23 | 25/25 | — | 20 | — | — | — |
| | CC20Y | 1 | 19.2 | 65.5 | 18.5 | 29 | 30/30 | — | 25 | — | — | — |
| | CC30Y | 1 | 28.8 | 98.25 | 27.7 | 40 | 40/40 | — | 35 | — | — | — |
| C102YL | CC40Y | 1 | 38.4 | 131 | 37 | 52 | 60/60 | — | 50 | — | — | — |
| | No Heat | — | — | — | — | 19 | 20/20 | — | — | 19 | 20/20 | — |
| | CC10Y | 1 | 9.6 | 32.75 | 9.2 | 19 | 20/20 | — | 15 | — | — | — |
| | CC15Y | 1 | 14.4 | 49.13 | 13.9 | 23 | 25/25 | — | 20 | — | — | — |
| | CC20Y | 1 | 19.2 | 65.5 | 18.5 | 29 | 30/30 | — | 25 | — | — | — |
| C120YL | CC30Y | 1 | 28.8 | 98.25 | 27.7 | 40 | 40/40 | — | 35 | — | — | — |
| | CC40Y | 1 | 38.4 | 131 | 37 | 52 | 60/60 | — | 50 | — | — | — |
| | No Heat | — | — | — | — | 19 | 20/20 | — | — | 19 | 20/20 | — |
| | CC10Y | 1 | 9.6 | 32.75 | 9.2 | 19 | 25/25 | — | 15 | — | — | — |
| | CC15Y | 1 | 14.4 | 49.13 | 13.9 | 23 | 25/25 | — | 20 | — | — | — |
| C151YL | CC20Y | 1 | 19.2 | 65.5 | 18.5 | 29 | 30/30 | — | 25 | — | — | — |
| | CC30Y | 1 | 28.8 | 98.25 | 27.7 | 40 | 40/40 | — | 35 | — | — | — |
| | CC40Y | 1 | 38.4 | 131 | 37 | 52 | 60/60 | — | 50 | — | — | — |
| | No Heat | — | — | — | — | 28 | 30/35 | — | — | 28 | 30/35 | — |
| | CC10Y | 1 | 9.6 | 32.75 | 9.2 | 28 | 30/35 | — | 15 | — | — | — |
| C151YL | CC15Y | 1 | 14.4 | 49.13 | 13.9 | 28 | 30/35 | — | 20 | — | — | — |
| | CC20Y | 1 | 19.2 | 65.5 | 18.5 | 34 | 35/35 | — | 25 | — | — | — |
| | CC30Y | 1 | 28.8 | 98.25 | 27.7 | 45 | 45/45 | — | 35 | — | — | — |
| | CC40Y | 1 | 38.4 | 131 | 37 | 57 | 60/60 | — | 50 | — | — | — |
| | CC50Y | 1 | 48 | 163.75 | 46.2 | 68 | 70/70 | — | 60 | — | — | — |

*= For Canadian use only. Uses "P" fuses for inductive circuit.
 += Field installed only.

UNITS WITH HEATER KITS—RLNL-C SERIES



| 600 VOLT, THREE PHASE, 60 HZ, AUXILIARY ELECTRIC HEATER KITS CHARACTERISTICS AND APPLICATION | | | | | | | | | | | | | |
|--|----------------------------|-----------------------|-------------------------|------------------------|---------------------|---------------------------------|---|---|--|----------------------|--------------------------|---|---|
| Single Power Supply For Both Unit and Heater Kit | | | | | | | | | | | | | |
| Unit Model No. RLNL- | Heater Kit | | | | Air Conditioner | | | | Separate Power Supply For Both Unit and Heater Kit | | | | |
| | RXJJ-Heater Kit Nominal kW | No. of Sequence Steps | Rated Heater kW @ 600 V | Heater KBTU/Hr @ 600 V | Heater Amp. @ 600 V | Unit Min. Ckt. Ampacity @ 600 V | Over Current Protective Device Size Min./Max. @ 600 V | Over Current Protective Device Size Min./Max. @ 600 V | Min. Ckt. Ampacity 600 V | Max. Fuse Size 600 V | Min. Ckt. Ampacity 600 V | Over Current Protective Device Size Min./Max. @ 600 V | Over Current Protective Device Size Min./Max. @ 600 V |
| C072YM | No Heat | — | — | — | — | 13 | 15/15 | 15/15 | 13 | — | 13 | 15/15 | — |
| | CC10Y | 1 | 9.6 | 32.75 | 9.2 | 14 | 15/15 | 15/15 | — | 15 | — | — | — |
| | CC15Y | 1 | 14.4 | 49.13 | 13.9 | 20 | 20/20 | 20/20 | — | 20 | — | — | — |
| | CC20Y | 1 | 19.2 | 65.5 | 18.5 | 26 | 30/30 | 30/30 | — | 25 | — | — | — |
| C090YM | CC30Y | 1 | 28.8 | 98.25 | 27.7 | 38 | 40/40 | 40/40 | — | 35 | — | — | — |
| | No Heat | — | — | — | — | 16 | 20/20 | 20/20 | 16 | — | 16 | 20/20 | — |
| | CC10Y | 1 | 9.6 | 32.75 | 9.2 | 17 | 20/20 | 20/20 | — | 15 | — | — | — |
| | CC15Y | 1 | 14.4 | 49.13 | 13.9 | 23 | 25/25 | 25/25 | — | 20 | — | — | — |
| C102YM | CC20Y | 1 | 19.2 | 65.5 | 18.5 | 29 | 30/30 | 30/30 | — | 25 | — | — | — |
| | CC30Y | 1 | 28.8 | 98.25 | 27.7 | 40 | 40/40 | 40/40 | — | 35 | — | — | — |
| | CC40Y | 1 | 38.4 | 131 | 37 | 52 | 60/60 | 60/60 | — | 50 | — | — | — |
| | No Heat | — | — | — | — | 24 | 25/30 | 25/30 | 24 | — | 24 | 25/30 | — |
| C120YM | CC10Y | 1 | 9.6 | 32.75 | 9.2 | 24 | 30/30 | 30/30 | — | 15 | — | — | — |
| | CC15Y | 1 | 14.4 | 49.13 | 13.9 | 28 | 30/30 | 30/30 | — | 20 | — | — | — |
| | CC20Y | 1 | 19.2 | 65.5 | 18.5 | 34 | 35/35 | 35/35 | — | 25 | — | — | — |
| | CC30Y | 1 | 28.8 | 98.25 | 27.7 | 45 | 45/45 | 45/45 | — | 35 | — | — | — |
| C151YM | CC40Y | 1 | 38.4 | 131 | 37 | 57 | 60/60 | 60/60 | — | 50 | — | — | — |
| | CC50Y | 1 | 48 | 163.75 | 46.2 | 68 | 70/70 | 70/70 | — | 60 | — | — | — |
| | No Heat | — | — | — | — | 28 | 30/35 | 30/35 | 28 | — | 28 | 30/35 | — |
| | CC10Y | 1 | 9.6 | 32.75 | 9.2 | 28 | 30/35 | 30/35 | — | 15 | — | — | — |
| C151YM | CC15Y | 1 | 14.4 | 49.13 | 13.9 | 28 | 30/35 | 30/35 | — | 20 | — | — | — |
| | CC20Y | 1 | 19.2 | 65.5 | 18.5 | 34 | 35/35 | 35/35 | — | 25 | — | — | — |
| | CC30Y | 1 | 28.8 | 98.25 | 27.7 | 45 | 45/45 | 45/45 | — | 35 | — | — | — |
| | CC40Y | 1 | 38.4 | 131 | 37 | 57 | 60/60 | 60/60 | — | 50 | — | — | — |
| C151YM | CC50Y | 1 | 48 | 163.75 | 46.2 | 68 | 70/70 | 70/70 | — | 60 | — | — | — |
| | No Heat | — | — | — | — | 28 | 30/35 | 30/35 | 28 | — | 28 | 30/35 | — |
| | CC10Y | 1 | 9.6 | 32.75 | 9.2 | 28 | 30/35 | 30/35 | — | 15 | — | — | — |
| | CC15Y | 1 | 14.4 | 49.13 | 13.9 | 28 | 30/35 | 30/35 | — | 20 | — | — | — |
| C151YM | CC20Y | 1 | 19.2 | 65.5 | 18.5 | 34 | 35/35 | 35/35 | — | 25 | — | — | — |
| | CC30Y | 1 | 28.8 | 98.25 | 27.7 | 45 | 45/45 | 45/45 | — | 35 | — | — | — |
| | CC40Y | 1 | 38.4 | 131 | 37 | 57 | 60/60 | 60/60 | — | 50 | — | — | — |
| | CC50Y | 1 | 48 | 163.75 | 46.2 | 68 | 70/70 | 70/70 | — | 60 | — | — | — |

*= For Canadian use only. Uses "Pr" fuses for inductive circuit.
 += Field installed only.

PACKAGE AIR CONDITIONER

SUPPLY AND RETURN DIMENSIONS FOR HORIZONTAL APPLICATIONS

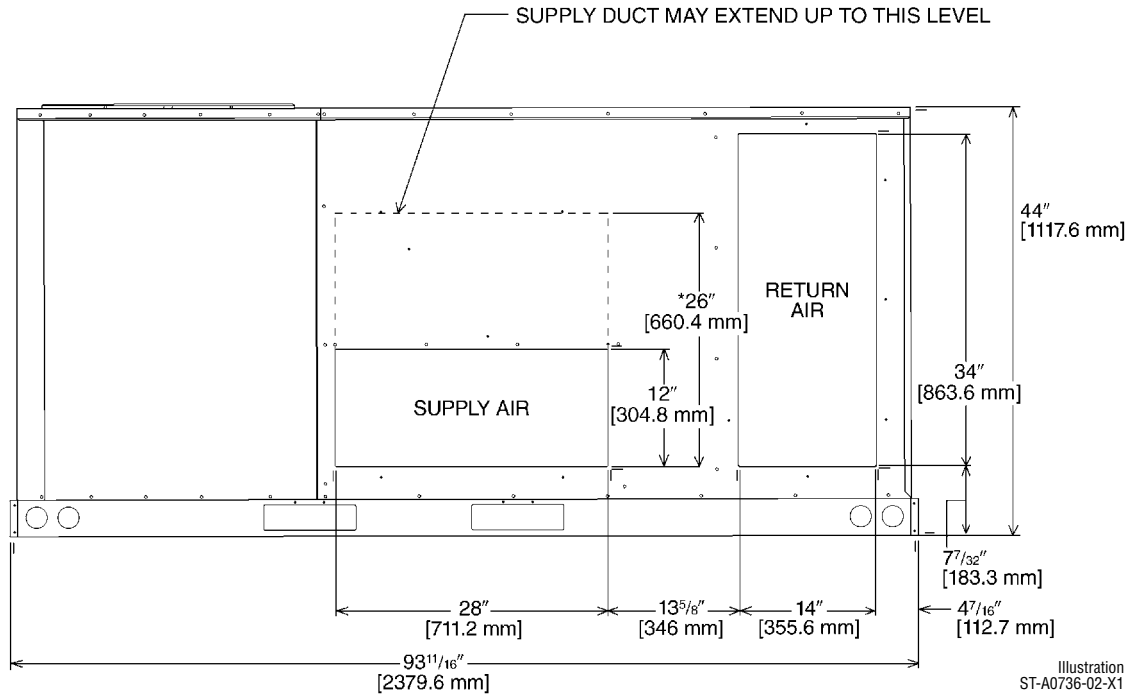

*RECOMMENDED DUCT DIMENSIONS ARE 26"

SUPPLY AND RETURN DIMENSIONS FOR DOWNFLOW APPLICATIONS

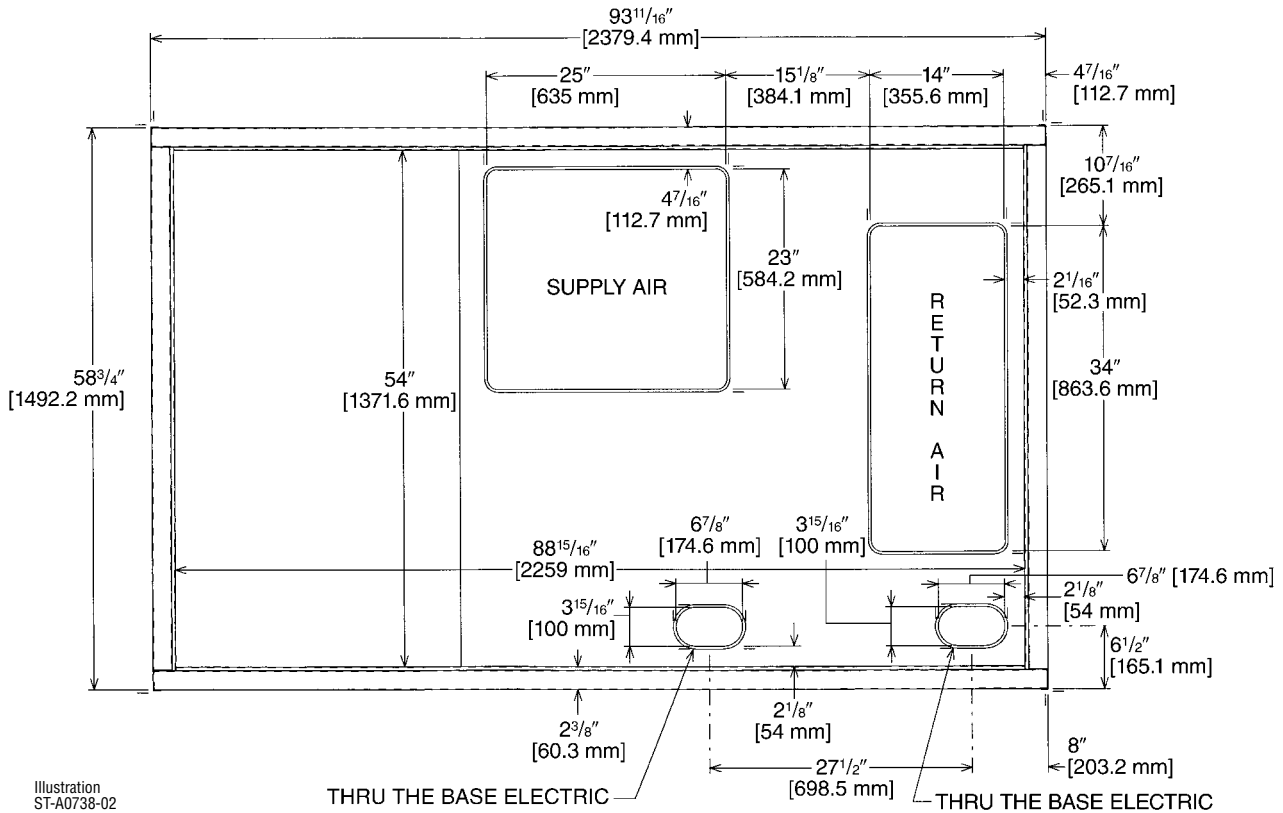

[] Designates Metric Conversions

PACKAGE AIR CONDITIONER

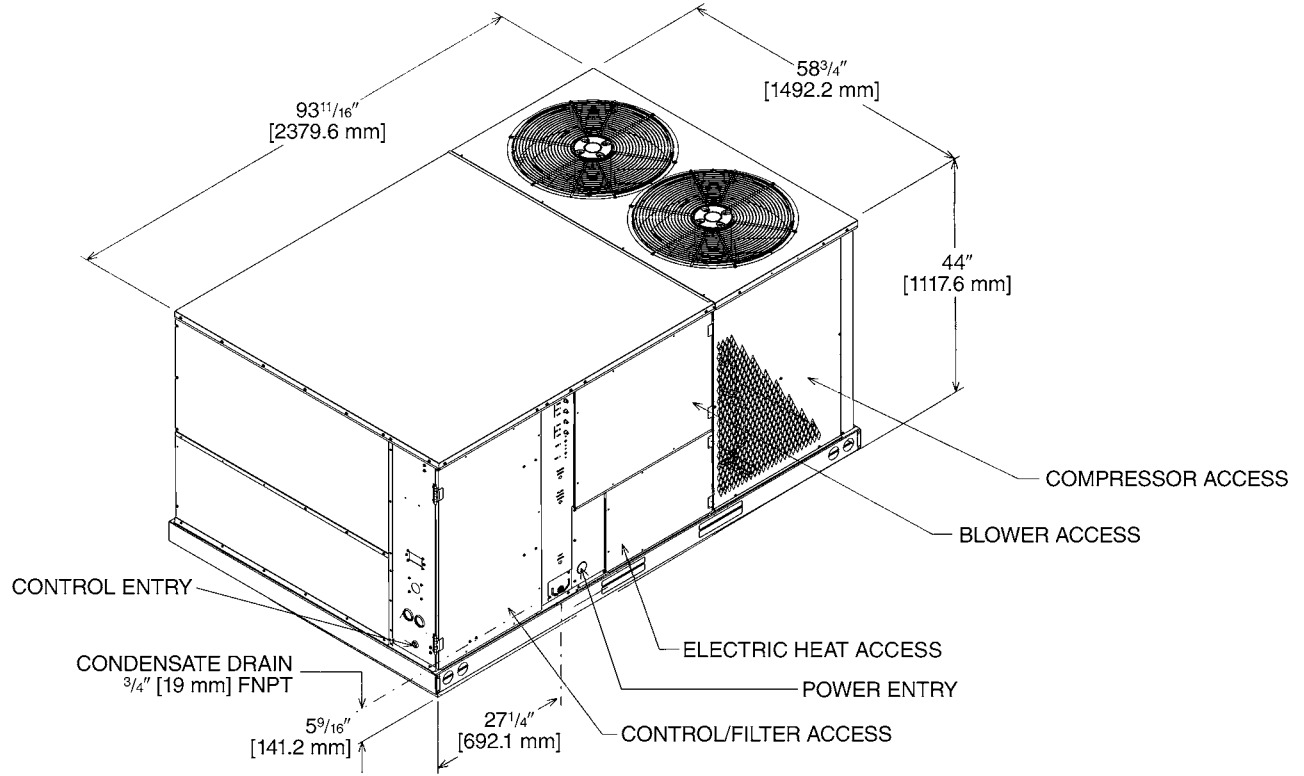

[] Designates Metric Conversions

WEIGHTS

| Accessory | Shipping—lbs [kg] | Operating—lbs [kg] |
|------------------------------|-------------------|--------------------|
| Economizer | 90 [40.82] | 81 [36.70] |
| Power Exhaust | 44 [19.96] | 42 [19.05] |
| Fresh Air Damper (Manual) | 26 [11.79] | 21 [9.53] |
| Fresh Air Damper (Motorized) | 43 [19.50] | 38 [17.24] |
| Roof Curb 14" | 90 [40.82] | 85 [38.60] |
| Roof Curb 24" | 140 [63.50] | 135 [61.23] |

| Capacity Tons [kW] | Corner Weights by Percentage | | | |
|--------------------|------------------------------|-----|-----|-----|
| | A | B | C | D |
| 6-12.5 [21.1-44.0] | 33% | 27% | 17% | 23% |

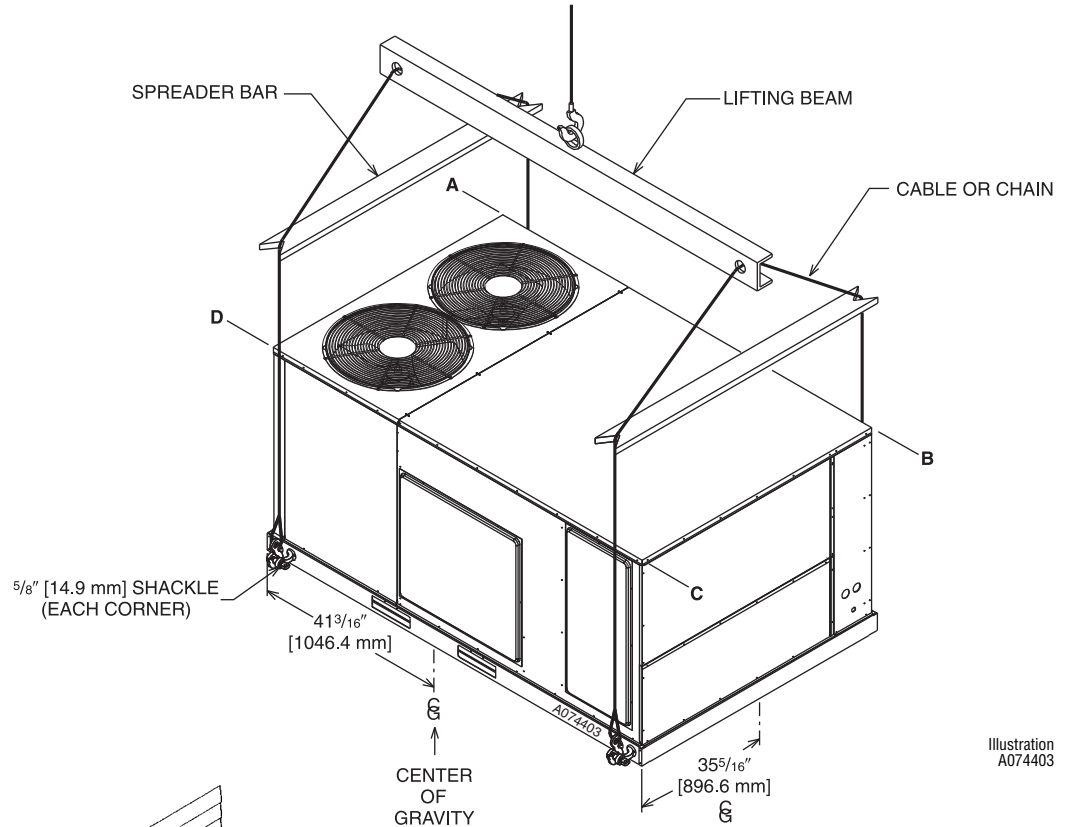
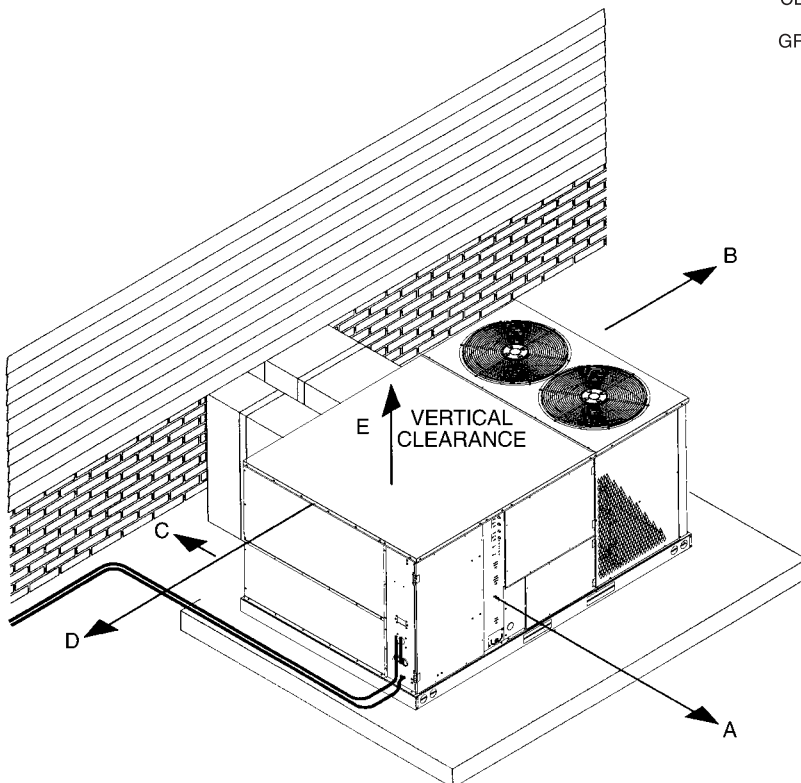

Illustration
A074403



CLEARANCES

The following minimum clearances must be observed for proper unit performance and serviceability.

| Recommended Clearance In. [mm] | Location |
|--|---------------------|
| 48 [1219] | A - Front |
| 18 [457] | B - Condenser Coil |
| 18 [457] | C - Duct Side |
| 18 [457] | *D - Evaporator End |
| 60 [1524] | E - Above |
| *Without Economizer. 48" [1219 mm] With Economizer | |

[] Designates Metric Conversions

FIELD INSTALLED ACCESSORY EQUIPMENT

| Accessory | Model Number | Shipping Weight Lbs. [kg] | Installed Weight Lbs. [kg] | Factory Installation Available? |
|--|--|------------------------------|-------------------------------|---------------------------------|
| Thermostats | See Thermostat Specification Sheet for Details (T22-001) | | | No |
| Electric Heaters | RXJJ-CC10 (C,D,Y) | 46 [20.9] | 36 [16.3] | Yes |
| | RXJJ-CC15 (C,D,Y) | 46 [20.9] | 36 [16.3] | Yes |
| | RXJJ-CC20 (C,D,Y) | 46 [20.9] | 36 [16.3] | Yes |
| | RXJJ-CC30 (C,D,Y) | 47 [21.3] | 37 [16.8] | Yes |
| | RXJJ-CC40 (C,D,Y) | 49 [22.2] | 39 [17.7] | Yes |
| | RXJJ-CC50 (C,D,Y) | 51 [23.1] | 41 [18.6] | Yes |
| Economizer w/Single Enthalpy | AXRD-PJCM3 | 90 [40.8] | 81 [36.7] | Yes |
| Economizer w/Single Enthalpy and Smoke Dectector | AXRD-SJCM3 | 91 [41.3] | 82 [37.2] | Yes |
| Dual Enthalpy Kit | RXR-AR03 | 1 [0.5] | 1 [0.5] | No |
| Horizontal Economizer w/Single Enthalpy | AXRD-RJCM3 | 94 [42.6] | 89 [40.4] | No |
| Carbon Dioxide Sensor | RXR-AR02 | 3 [1.4] | 2 [1.0] | No |
| Power Exhaust | RXR-BFF02 (C,D,Y) | 43 [19.5] | 38 [17.2] | No |
| Manual Fresh Air (Left Panel Mounted) | AXRF-KDA1 | 38 [17.2] | 31 [14.0] | No |
| Manual Fresh Air (Return Panel) | AXRF-JDA1 | 26 [11.8] | 21 [9.5] | No |
| Motorized Fresh Air (Return Panel) | AXRF-JDB1 | 43 [19.5] | 21 [9.5] | No |
| Motor Kit for RXRF-KDA1 (Left Panel Mounted) | RXR-AW02 | 35 [15.19] | 27 [17.7] | No |
| Modulating Motor Kit w/position feedback for RXRF-KDA1 | RXR-AW04 | 38 [17.2] | 30 [13.6] | No |
| Roofcurb, 14" | RXKG-CAE14 | 90 [40.8] | 85 [38.5] | No |
| Roofcurb, 24" | RXKG-CAE24 | 140 [63.5] | 135 [61.2] | No |
| Roofcurb Adapters | RXR-CDCE50 | 300 [136.1] | 290 [131.5] | No |
| | RXR-CFCE54 | 325 [147.4] | 315 [142.9] | No |
| | RXR-CFCE56 | 350 [158.8] | 340 [154.2] | No |
| | RXR-CGCC12 | 450 [204.1] | 410 [186.0] | No |
| Concentric Diffuser (Step-Down, 18 x 28) | RXR-AA61 | 200 [90.7] | 185 [83.9] | No |
| Concentric Diffuser (Step-Down, 18 x 32) | RXR-AA66 | 247 [112.0] | 227 [103.0] | No |
| Concentric Diffuser (Flush, 18 x 28) | RXR-AA71 | 170 [77.1] | 155 [70.3] | No |
| Concentric Diffuser (Flush, 18 x 32) | RXR-AA76 | 176 [79.8] | 161 [73.0] | No |
| Downflow Adapters (Rect. to Round) | RXMC-CD04 | 15 [6.8] | 13 [5.9] | No |
| Downflow Adapters (Rect. to Rect., 18 x 28) | RXMC-CE05 ① | 18 [8.2] | 16 [7.3] | No |
| Downflow Adapters (Rect. to Rect., 18 x 32) | RXMC-CF06 ② | 20 [9.1] | 18 [8.2] | No |
| Low-Ambient Control Kit (1 Per Compressor) | RXR-C02 | 3 [1.4] | 2 [1.0] | Yes |
| Outdoor Coil Louver Kit | AXRX-AAD01C (6-10 Ton) | 29 [11.3] | 26 [11.8] | Yes |
| Outdoor Louver Kit | AXRX-AAD02A (12.5 Ton) | 29 [11.3] | 26 [11.8] | Yes |
| Unwired Convenience Outlet | RXR-AN01 | 2 [1.0] | 1.5 [0.7] | Yes |
| Comfort Alert (1 per compressor) | RXR-AZ01 | 3 [1.4] | 2 [0.9] | Yes |
| BACnet Communication Card | RXR-AY01 | 1 [0.5] | 1 [0.5] | No |
| LonWorks Communication Card | RXR-AY02 | 1 [0.5] | 1 [0.5] | No |

NOTES: ① Used with RXRN-AA61 and RXRN-AA71 concentric diffusers.

② Used with RXRN-AA66 and RXRN-AA76 concentric diffusers.

[] Designates Metric Conversions

THERMOSTAT



100-Series *
Non-Programmable



200-Series *
Programmable



300-Series *
Deluxe
Programmable



400-Series *
Special Applications/
Programmable

500-Series *
Communicating/
Programmable

| Brand | Unique Model Number Prefix | Descriptor (3 Characters) | Series (3 Characters) | System (2 Characters) | Type (2 Characters) |
|----------|----------------------------|---------------------------|--|---|-----------------------------------|
| UHC | - | TST | 101 | GE | MS |
| UHC=Ruud | | TST=Thermostat | 100=Non-Programmable 200=Programmable 300=Deluxe Programmable 400=Special Applications/ Programmable 500=Communicating/ Programmable | GE=Gas/Oil/Electric HP=Heat Pump MD=Modulating Furnace DF=Dual Fuel UN=Universal AC/HP/GE CM=Communicating | SS=Single-Stage MS=Multi-Stage |

* Photos are representative. Actual models may vary.

For detailed thermostat match-up information, see specification sheet form number T22-001.

FLUSH MOUNT ROOM TEMPERATURE SENSORS FOR NETWORKED DDC APPLICATIONS



ROOM TEMPERATURE SENSOR ZNS-101
with **TIMED OVERRIDE BUTTON**

10k Ω room temperature sensor transmits room temperature to DDC system. Timed override button allows tenant to change from unoccupied temperature setpoint to occupied temperature setpoint for a preset time.



ROOM TEMPERATURE SENSOR ZNS-102
with **TIMED OVERRIDE BUTTON** and **STATUS INDICATOR**

10k Ω room temperature sensor transmits room temperature to DDC system. Timed override button allows tenant to change from unoccupied temperature setpoint to occupied temperature setpoint for a preset time. Status Indicator Light transmits ALARM flash code to occupied space.



ROOM TEMPERATURE SENSOR ZNS-103
with **SETPOINT ADJUSTMENT** and **TIMED OVERRIDE BUTTON**

10k Ω room temperature sensor with setpoint adjustment transmits room temperature to DDC system along with desired occupied room temperature setpoint. Timed override button allows tenant to change from unoccupied temperature setpoint to occupied temperature setpoint for a preset time.

COMMUNICATION CARDS

Field Installed



BACnet® COMMUNICATION CARD RXRX-AY01

The field installed BACnet® Communication Card allows the RTU-C unit controller to communicate with a third party building management system that supports the BACnet Application Specific Controller device profile. The BACnet® Communication Module plugs onto the unit RTU-C controller and allows communication between the RTU-C and the BACnet MSTP network.



LonWorks® COMMUNICATION CARD RXRX-AY02

The field installed LonWorks® Communication Card allows the RTU-C unit controller to communicate with a third party building management system that supports the LonMark Space Comfort Controller (SCC) functional profile or LonMark Discharge Air Controller (DAC) functional profile. The LonMark Communication Module plugs onto the RTU-C controller and allows communication between the RTU-C and a LonWorks Network.

ECONOMIZER FOR DOWNFLOW DUCT INSTALLATION

Use to Select Factory Installed Options Only

AXRD-PJCM3—Single Enthalpy (Outdoor) and RXRD-SJCM3 Single Enthalpy with Smoke Detector

RXXR-AV03—Dual Enthalpy Upgrade Kit

RXXR-AR02—Optional Wall-Mounted CO₂ Sensor

- Features **Honeywell** Controls
- Available Factory Installed or Field Accessory
- Gear Driven Direct Drive Actuator
- Fully Modulating (0-100%)
- Low Leakage Dampers
- Slip-In Design for Easy Installation
- Plug-In Polarized 12-pin and 4-pin Electrical Connections
- Pre-Configured—No Field Adjustments Necessary
- Standard Barometric Relief Damper
- Single Enthalpy with Dual Enthalpy Upgrade Kit Available
- CO₂ Input Sensor Available
- Field Assembled Hood Ships with Economizer
- Economizer Ships Complete for Downflow Duct Application.
- Optional Remote Minimum Position Potentiometer (270 ohm) (Honeywell #S963B1136) is Available from Prostock.
- Field Installed Power Exhaust Available
- Prewired for Smoke Detector
- If connected to a Building Automation System (BAS), all economizer functions can be viewed on the (BAS) or 16 x 2 LCD screen
- If connected to thermostat, all economizer functions can be viewed on 16 x 2 LCD screen

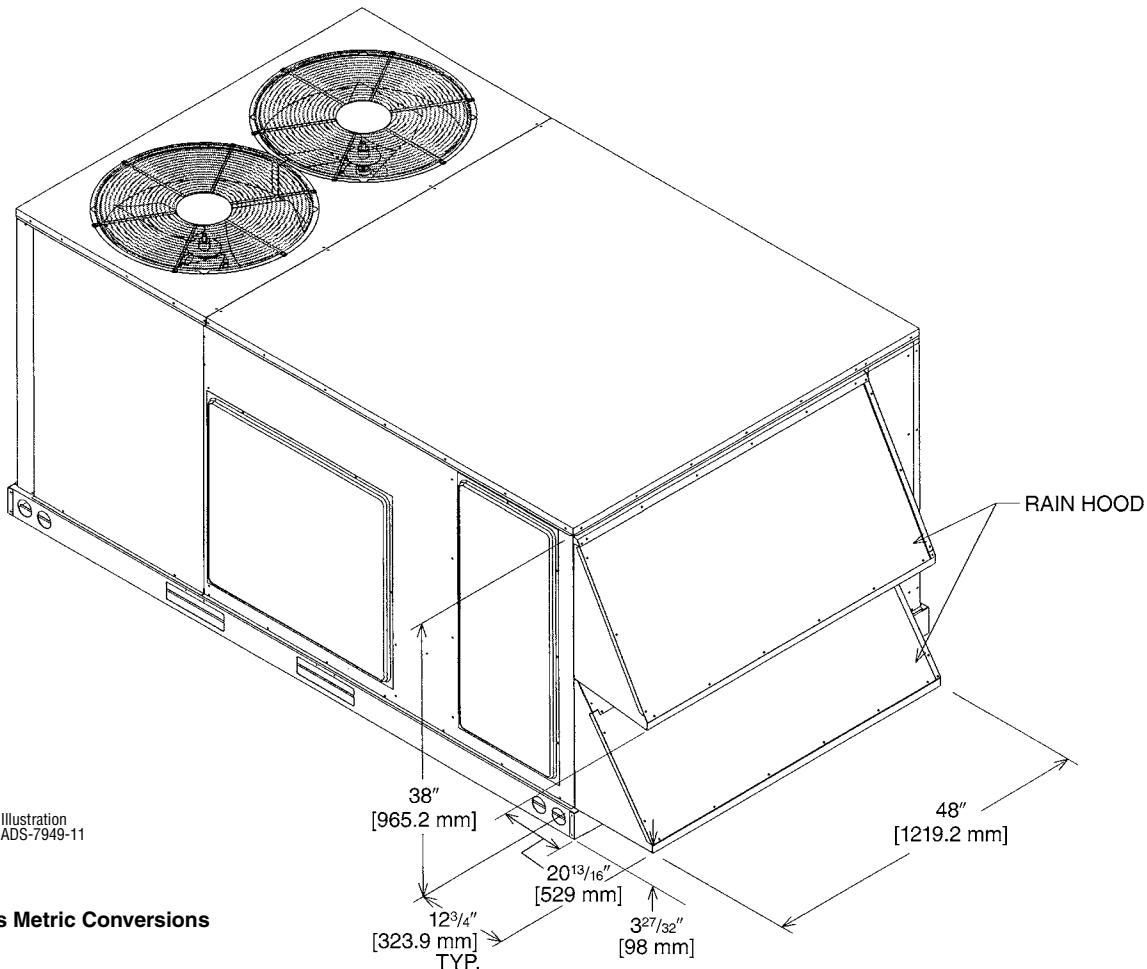
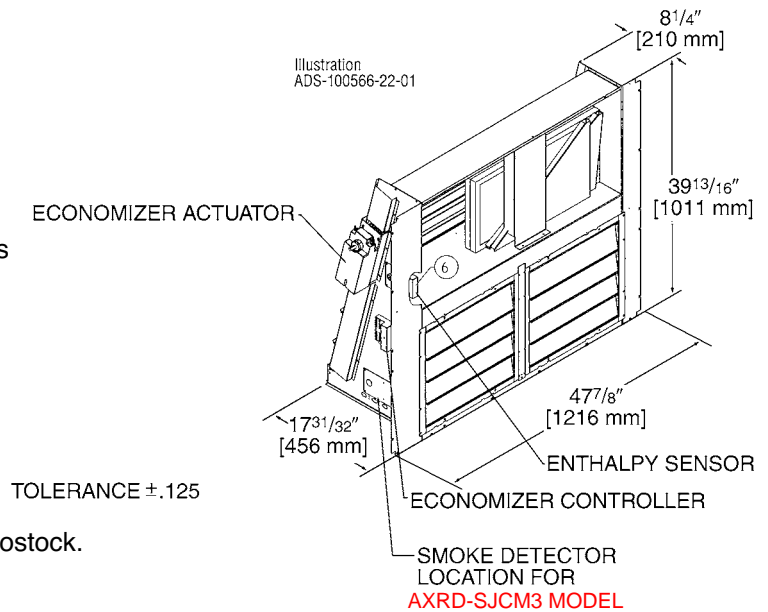

[] Designates Metric Conversions

ECONOMIZER FOR HORIZONTAL DUCT INSTALLATION

Field Installed Only

AXRD-RJCM3—Single Enthalpy (Outdoor)

RXXR-AV03—Dual Enthalpy Upgrade Kit

RXXR-AR02—Wall-mounted CO₂ Sensor

- Features **Honeywell** Controls
- Available as a Field Installed Accessory Only
- Gear Driven Direct Drive Actuator
- Fully Modulating (0-100%)
- Low Leakage Dampers
- Slip-In Design for Easy Installation
- Plug-In Polarized 12-pin and 4-pin Electrical Connections
- Pre-Configured—No Field Adjustments Necessary
- Standard Barometric Relief Damper
- Single Enthalpy with Dual Enthalpy Upgrade Kit Available
- CO₂ Input Sensor Available
- Field Assembled Hood Ships with Economizer
- Economizer Ships Complete for Horizontal Duct Application
- Optional Remote Minimum Position Potentiometer (270 ohm) (Honeywell #S963B1136) is Available from Prostock
- Field Installed Power Exhaust Available
- If connected to a Building Automation System (BAS), all economizer functions can be viewed on the (BAS) or 16 x 2 LCD screen
- If connected to thermostat, all economizer functions can be viewed on 16 x 2 LCD screen

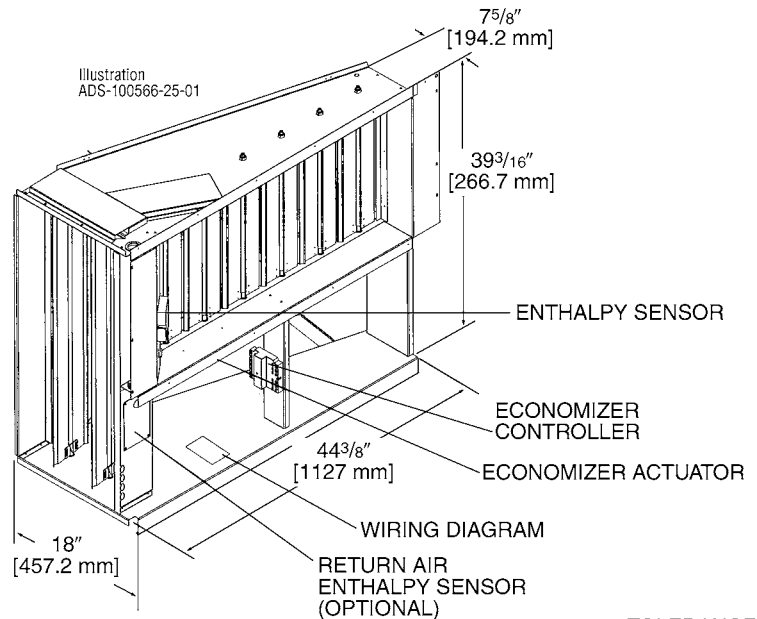

TOLERANCE ± .125

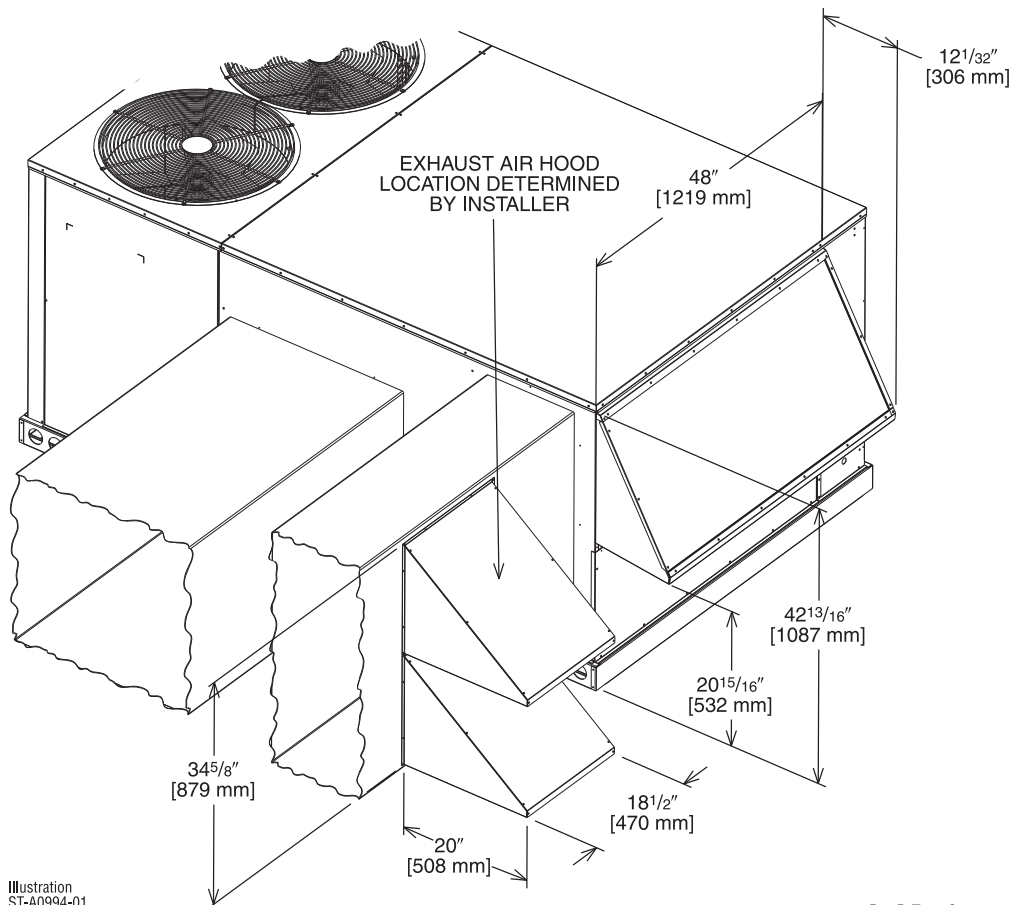

Illustration ST-A0994-01

[] Designates Metric Conversions

POWER EXHAUST KIT FOR AXRD-PJCM3(-), AXRD-RJCM3(-), AXRD-SJCM3 ECONOMIZERS

RXXR-BFF02 (C, D, or Y*)

*Voltage Code

VERTICAL AIRFLOW

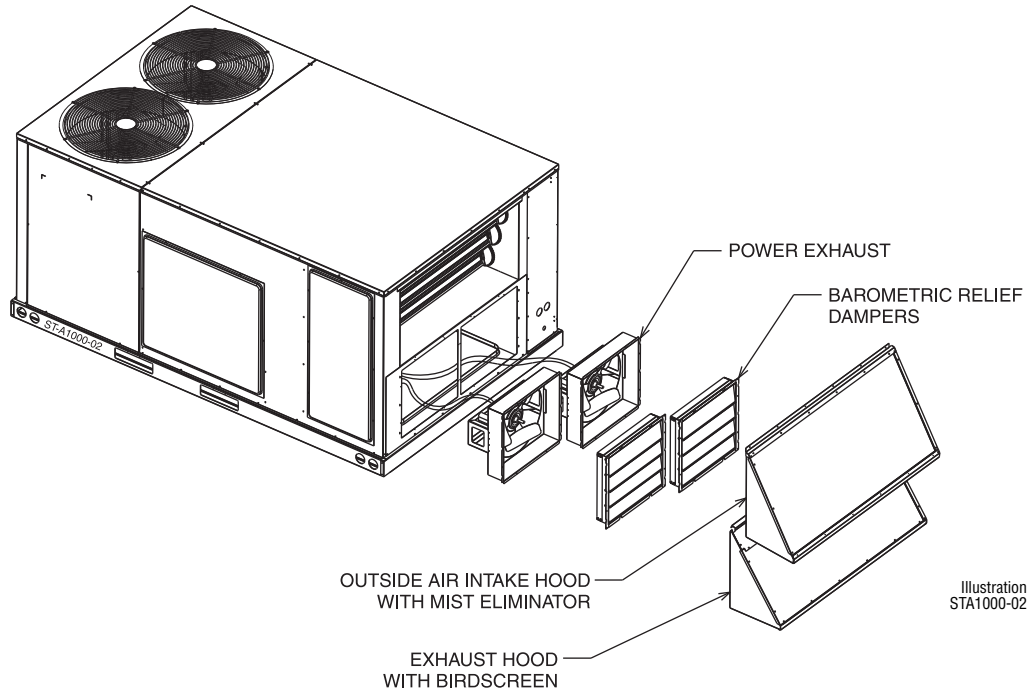

HORIZONTAL AIRFLOW

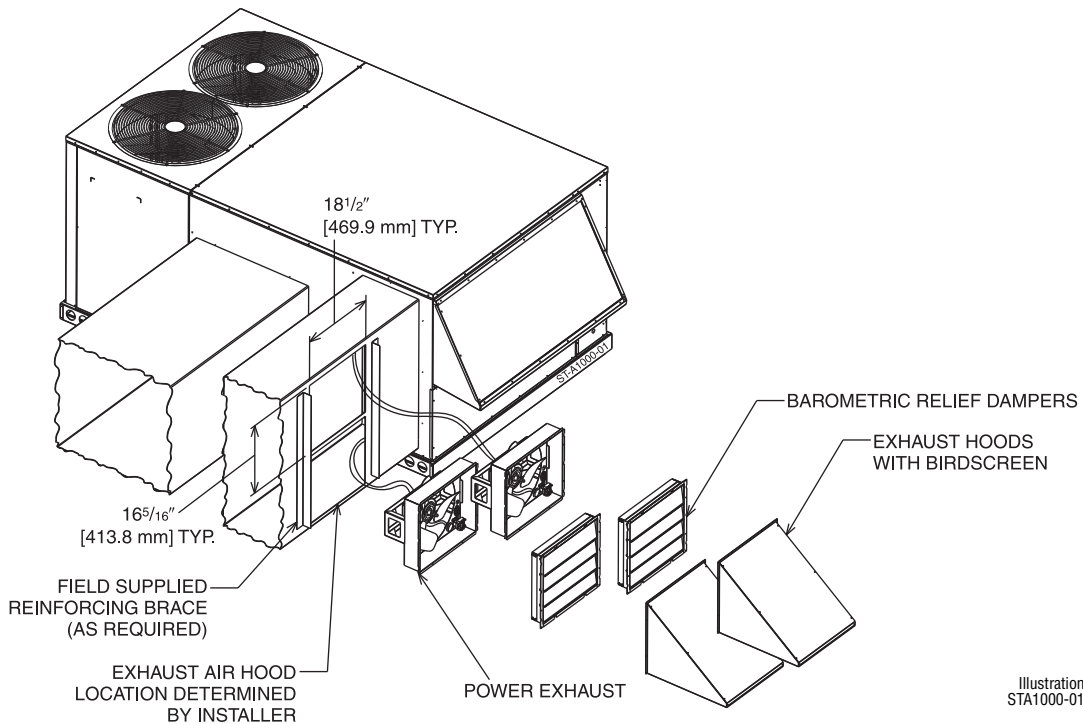

| Model No. | No. of Fans | Volts | Phase | HP (ea.) | Low Speed | | High Speed ① | | FLA (ea.) | LRA (ea.) |
|-------------|-------------|---------|-------|----------|-------------|------|--------------|------|-----------|-----------|
| | | | | | CFM [L/s] ② | RPM | CFM [L/s] ② | RPM | | |
| RXXR-BFF02C | 2 | 208-230 | 1 | 0.33 | 2200 [1038] | 1518 | 2500 [1179] | 1670 | 1.48 | 3.6 |
| RXXR-BFF02D | 2 | 460 | 1 | 0.33 | 2200 [1038] | 1518 | 2500 [1179] | 1670 | 0.75 | 1.8 |
| RXXR-BFF02Y | 2 | 575 | 1 | 0.33 | 2200 [1038] | 1518 | 2500 [1179] | 1670 | 0.81 | 1.5 |

NOTES: ① Power exhaust is factory set on high speed motor tap.
 ② CFM is per fan at 0" w.c. external static pressure.

[] Designates Metric Conversions

FRESH AIR DAMPER

**MOTORIZED DAMPER KIT
RXRX-AW02
(Motor Kit for AXRF-KDA1)**

**RXRX-AW04
(Modulating Motor Kit with position feedback for AXRF-KDA1)**

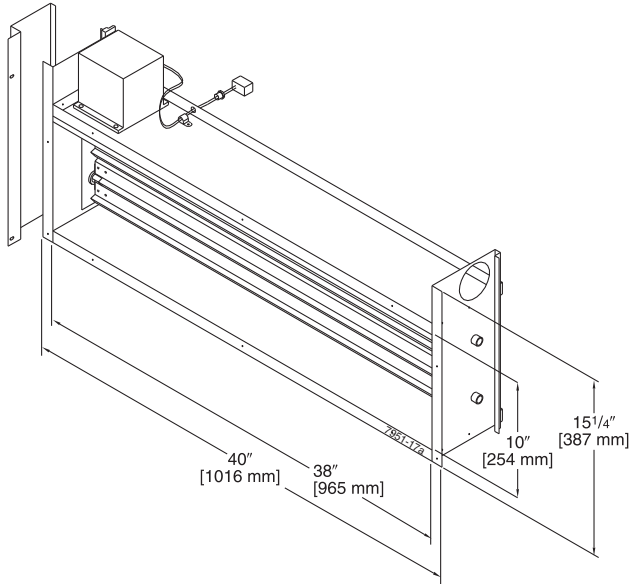

Illustration
ST-7951-17

**AXRF-KDA1 (Manual)
DOWNFLOW OR
HORIZONTAL APPLICATION**

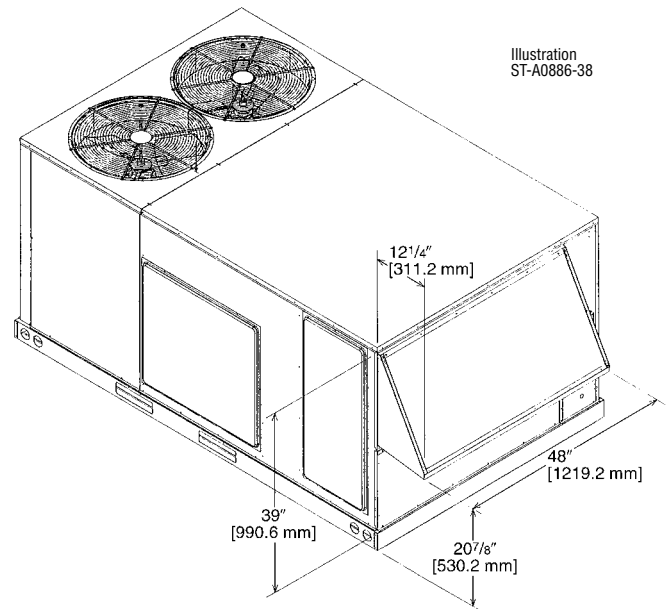

Illustration
ST-A0886-38

**MOTORIZED DAMPER KIT
RXRX-AW02
(Motor Kit for AXRF-KDA1)**

**RXRX-AW04
(Modulating Motor Kit w/position feedback for AXRF-KDA1)**

- Features **Honeywell** Controls
- Gear Driven Direct Drive Actuator
- Fully Modulating (0-100%)
- Low Leakage Dampers
- Slip-In Design for Easy Installation
- Plug-In Polarized 12-pin and 4-pin Electrical Connections
- Pre-Configured—No Field Adjustments Necessary
- Addition of Dual Enthalpy Upgrade Kit allows limited economizer function
- CO₂ Sensor Input Available for Demand Control Ventilation (DCV)
- Optional Remote Minimum Position Potentiometer (270 ohm) (Honeywell #S963B1136) is available from Prostock
- All fresh air damper functions can be viewed at the RTU-C unit controller display
- If connected to a Building Automation System (BAS), all fresh air damper functions can be viewed on the (BAS)

[] Designates Metric Conversions

FRESH AIR DAMPER (Cont.)

AXRF-JDA1 (Manual)
AXRF-JDB1 (Motorized)

DOWNFLOW APPLICATION

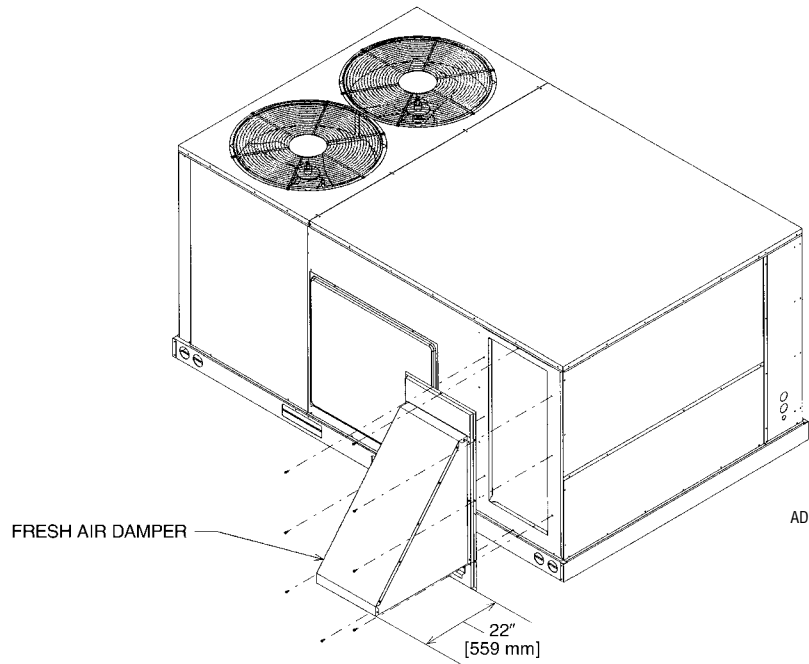
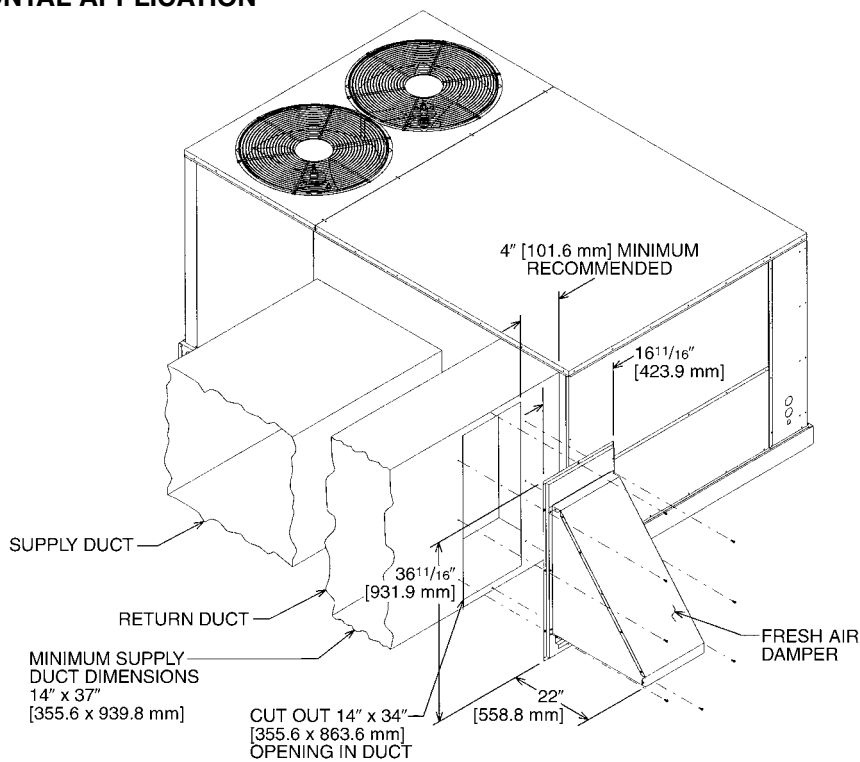

Illustration
ADS-7937-58

HORIZONTAL APPLICATION

Illustration
ST-A0901-01



[] Designates Metric Conversions

ROOFCURBS (Full Perimeter)

- Ruud's roofcurb design can be utilized on all 6-12.5 ton [21.1-44.0 kW] RLNL-C models.
- Two available heights (14" [356 mm] and 24" [610 mm]) for ALL models.
- Quick assembly corners for simple and fast assembly.
- Opening provided in bottom pan to match the "Thru the Curb" electrical connection opening provided on the unit base pan.
- 1" [25 mm] x 4" [102 mm] Nailer provided.
- Insulating panels not required because of insulated outdoor base pan.
- Sealing gasket (40' [12.2 m]) provided with Roofcurb.
- Packaged for easy field assembly.

| Roofcurb Model | Height of Curb |
|----------------|----------------|
| RXKG-CAE14 | 14" [356 mm] |
| RXKG-CAE24 | 24" [610 mm] |

TYPICAL INSTALLATION

Illustration ST-A0743-02

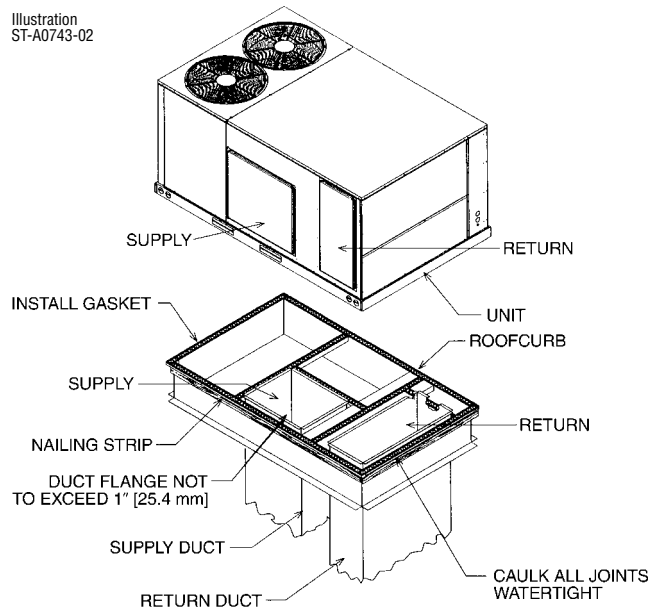

ROOFCURB INSTALLATION

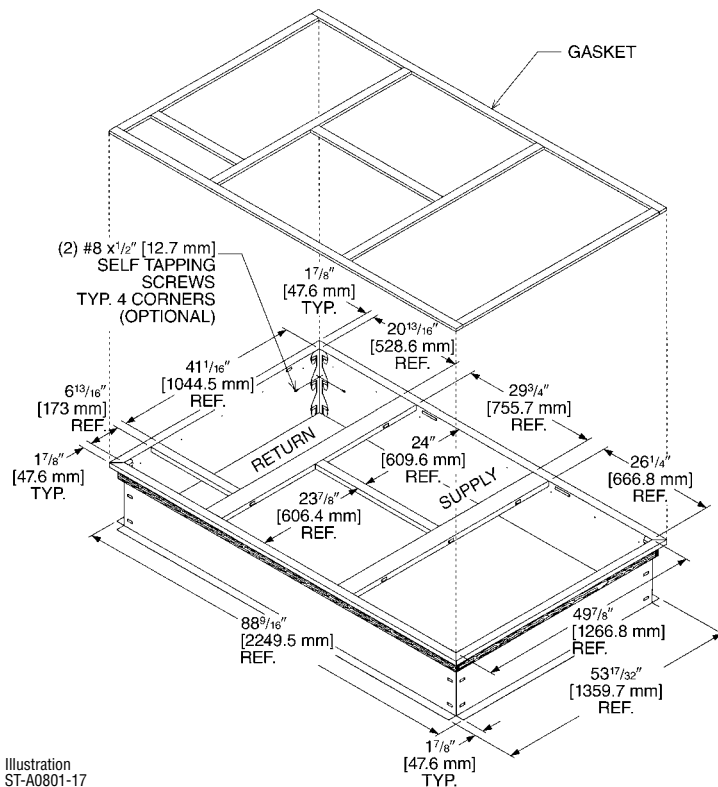
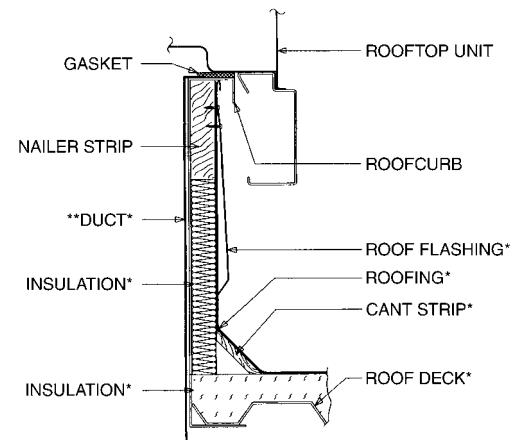

Illustration ST-A0801-17



*BY CONTRACTOR

**FOR INSTALLATION OF DUCT AS SHOWN, USE RECOMMENDED DUCT SIZES FROM ROOFCURB INSTALLATION INSTRUCTIONS. FOR DUCT FLANGE ATTACHMENT TO UNIT, SEE UNIT INSTALLATION INSTRUCTIONS FOR RECOMMENDED DUCT SIZES.

Illustration ST-A0743-02

[] Designates Metric Conversions

ROOFCURB ADAPTERS

| OLD MODELS | OLD ROOFCURB | ROOFCURB ADAPTER | NEW MODELS (All Share Common Cabinet) |
|---|--------------|------------------|---|
| (-)RCF, (-)REF-075/076 (-)RGF-150075, (-)RGF-131076 (-)RGF-201076 | RXRK-E50 | RXRX-CDCE50 | (R)LNL-C072 (R)LNL-C090 (R)LNL-C102 (R)LNL-C120 (R)LNL-C151 |
| (-)RGF-200075 (-)RGG, (-)REG, (-)RCG-075 (-)RGF, (-)REF, (-)RCF-085 (-)RGF, (-)REF, (-)RCF-100 (-)RGG, (-)REG, (-)RCG-100 | RXRK-E54 | RXRX-CFCE54 | |
| (-)RGF, (-)REF, (-)RCF-125 | RXRK-E56 | RXRX-CFCE56 | |
| (-)PDC-075 (-)PDC-100/101 | RXPK-C12 | RXRX-CGCC12 | |

NOTE: Ductwork modifications may be necessary if the capacity and/or indoor airflow rate of replacement unit is not equivalent to that of the unit being replaced.
 RLNL-C072, C090, C102, C120, C151 fit on same roofcurb as the RLKB-A090, A102, A120, A150, A181, RLMB- A090, A102, A120, A150, RLNB- A090, A102, A120

ROOFCURB ADAPTERS (Cont.)

RXRX-CDCE50

Illustration
ADS-7952-02
Sheet 2

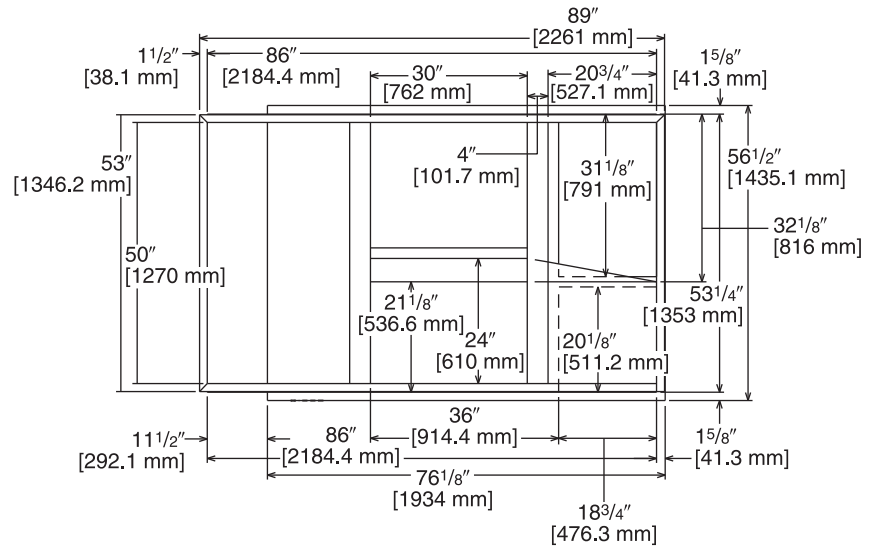

TOP VIEW

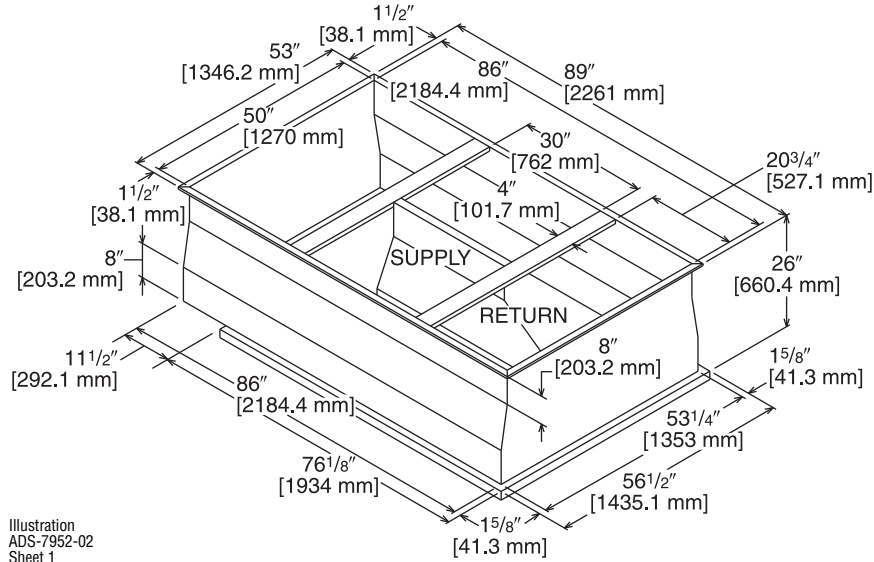

Illustration
ADS-7952-02
Sheet 1

[] Designates Metric Conversions

ROOFCURB ADAPTERS (Cont.)

RXRX-CFCE54

Illustration
ADS-7952-01
Sheet 2

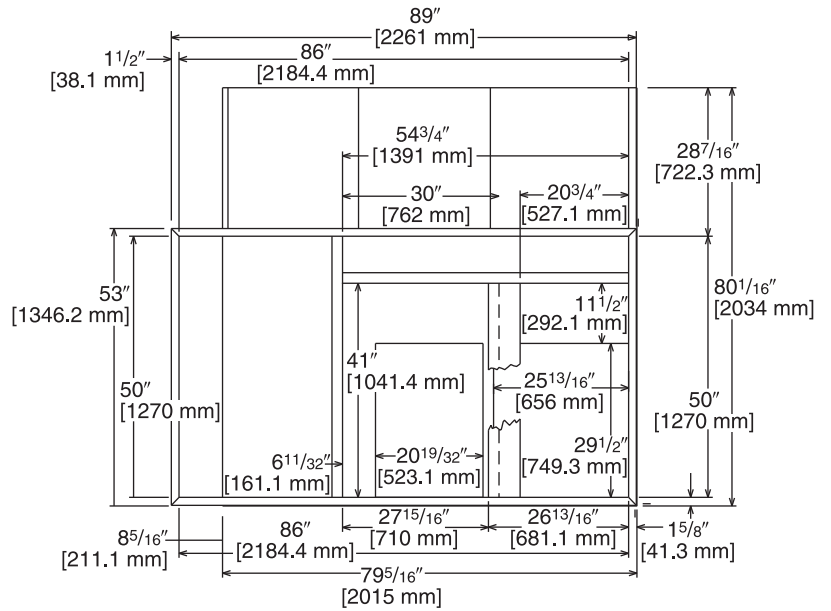

TOP VIEW

Illustration
ADS-7952-01
Sheet 1

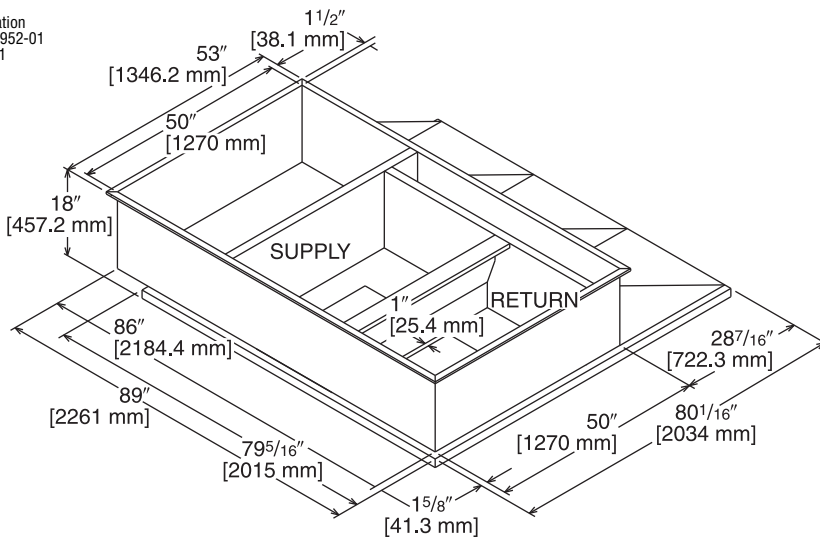

[] Designates Metric Conversions

ROOFCURB ADAPTERS (Cont.)

RXRX-CFCE56

Illustration
ADS-7952-03
Sheet 2

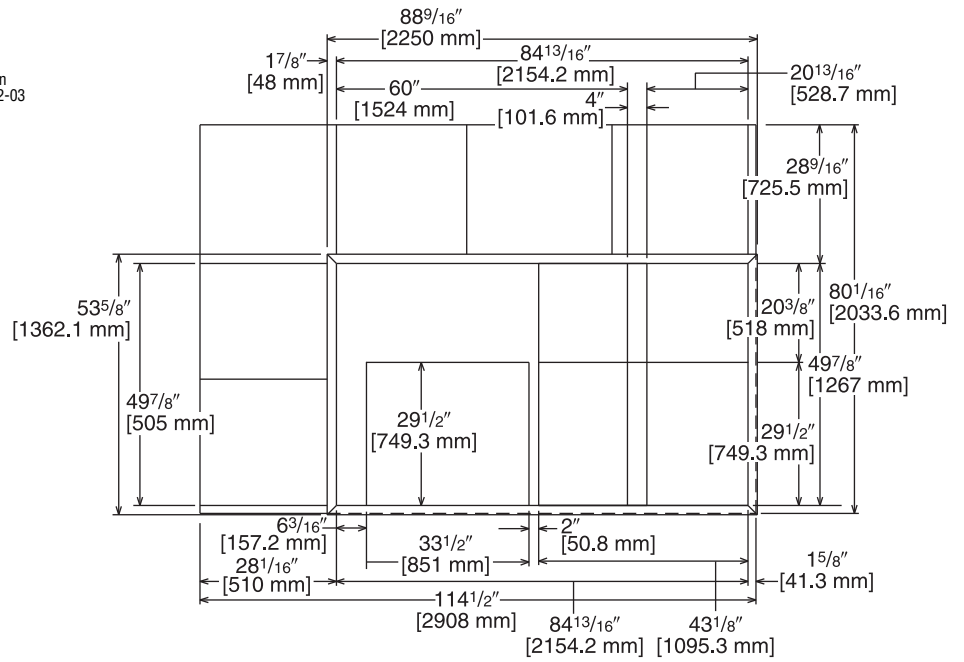

TOP VIEW

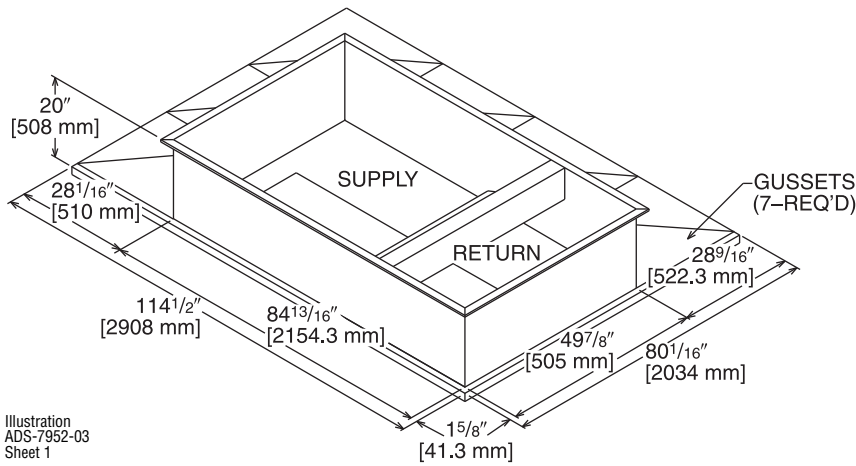

Illustration
ADS-7952-03
Sheet 1

[] Designates Metric Conversions

ROOFCURB ADAPTERS (Cont.)

RXRX-CGCC12

Illustration
ADS-7952-04
Sheet 2

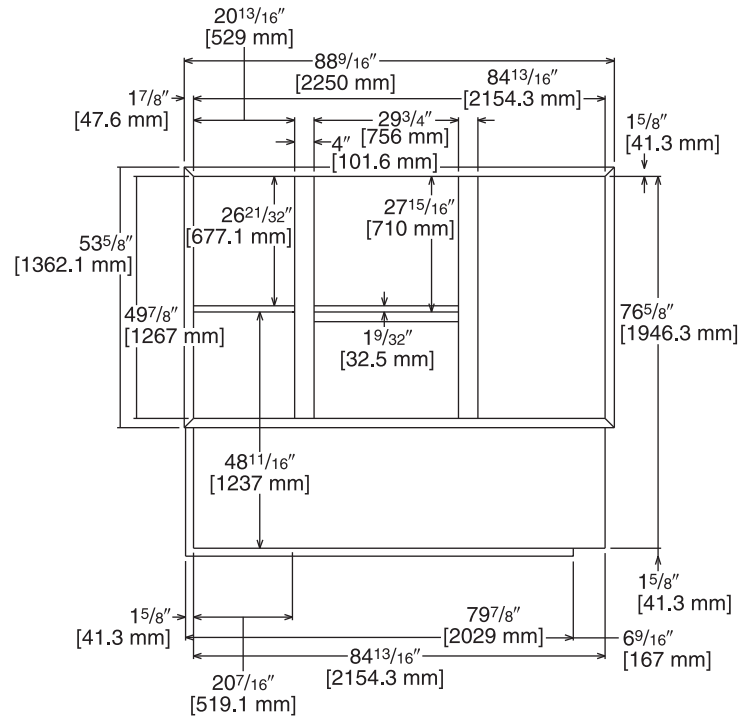

TOP VIEW

Illustration
ADS-7952-04
Sheet 1

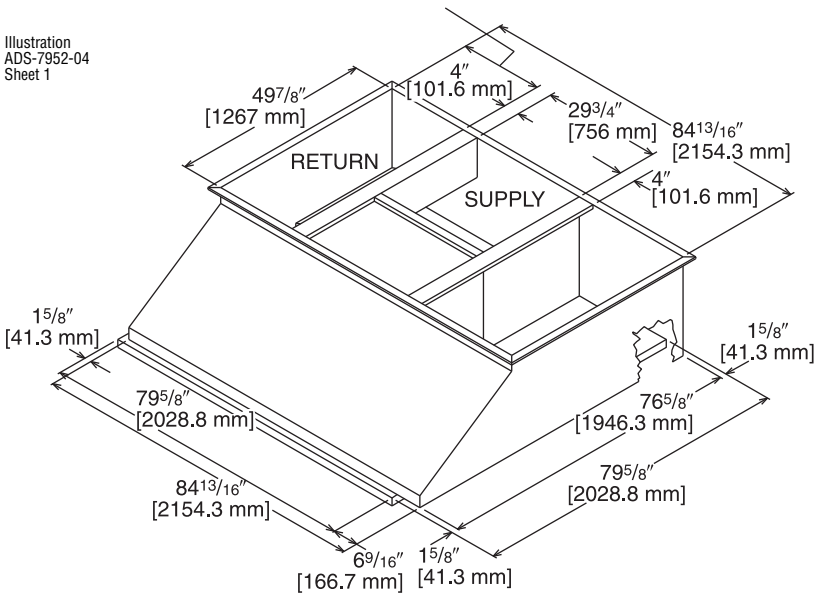

[] Designates Metric Conversions

CONCENTRIC DIFFUSER APPLICATION

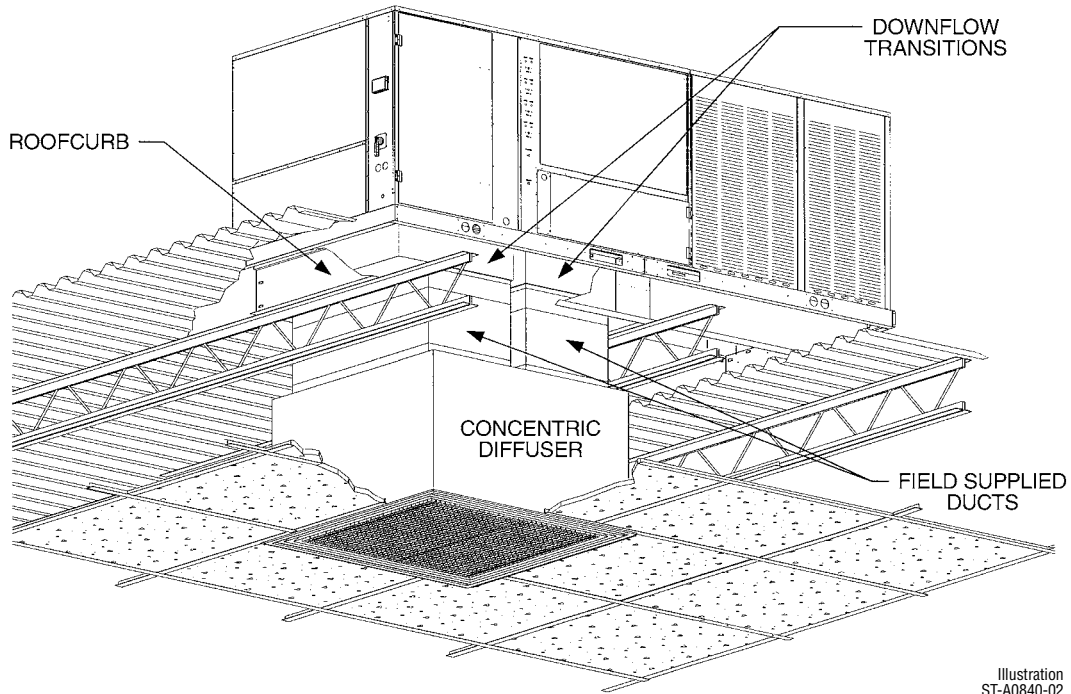

Illustration
ST-A0840-02

DOWNFLOW TRANSITION DRAWINGS

RXMC-CE05

- Used with RXRN-AA61 or RXRN-AA71 Concentric Diffusers.

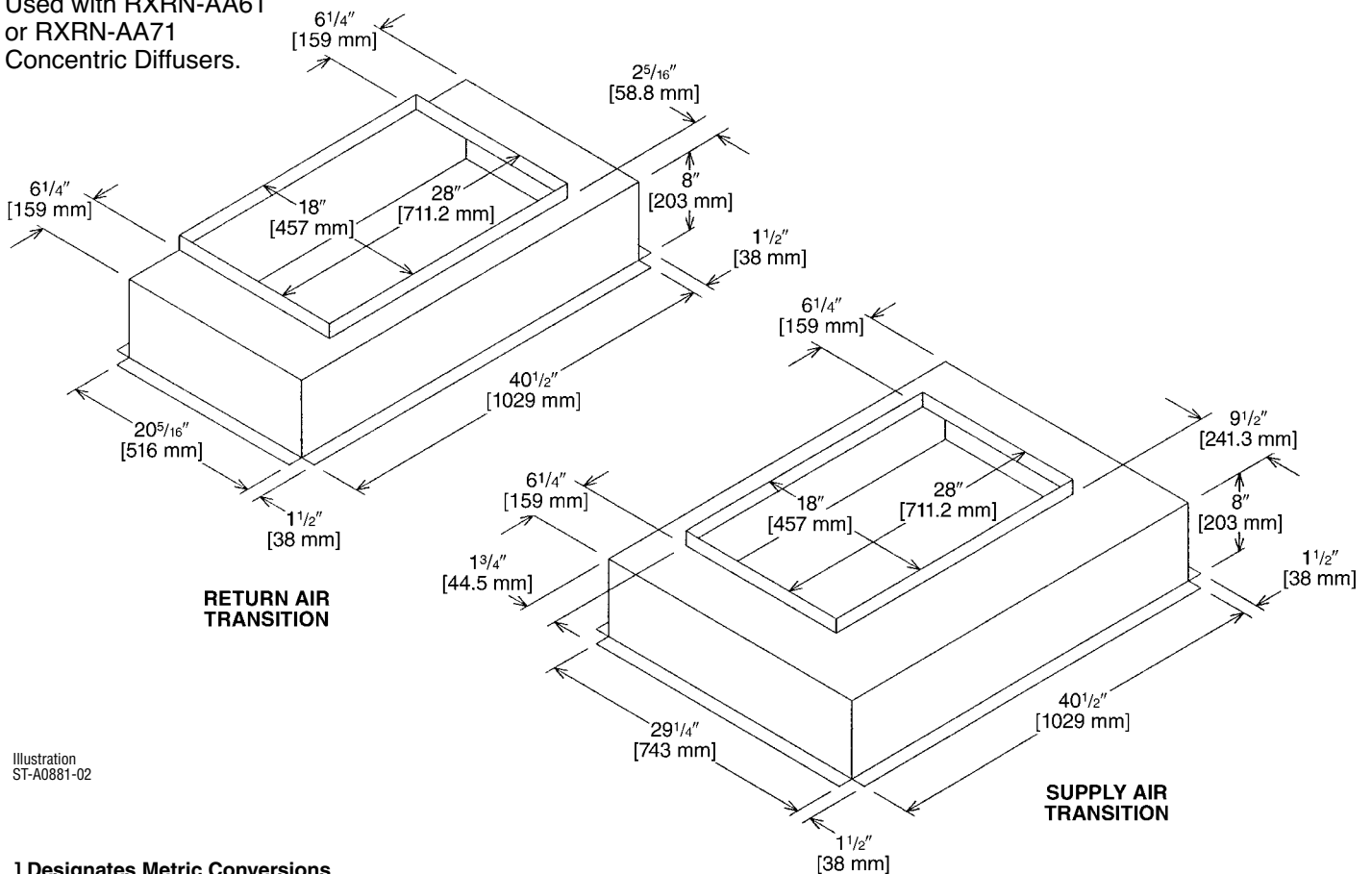

Illustration
ST-A0881-02

[] Designates Metric Conversions

DOWNFLOW TRANSITION DRAWINGS (Cont.)

RXMC-CF06

- Used with RXRN-AA66 or RXRN-AA76 Concentric Diffusers.

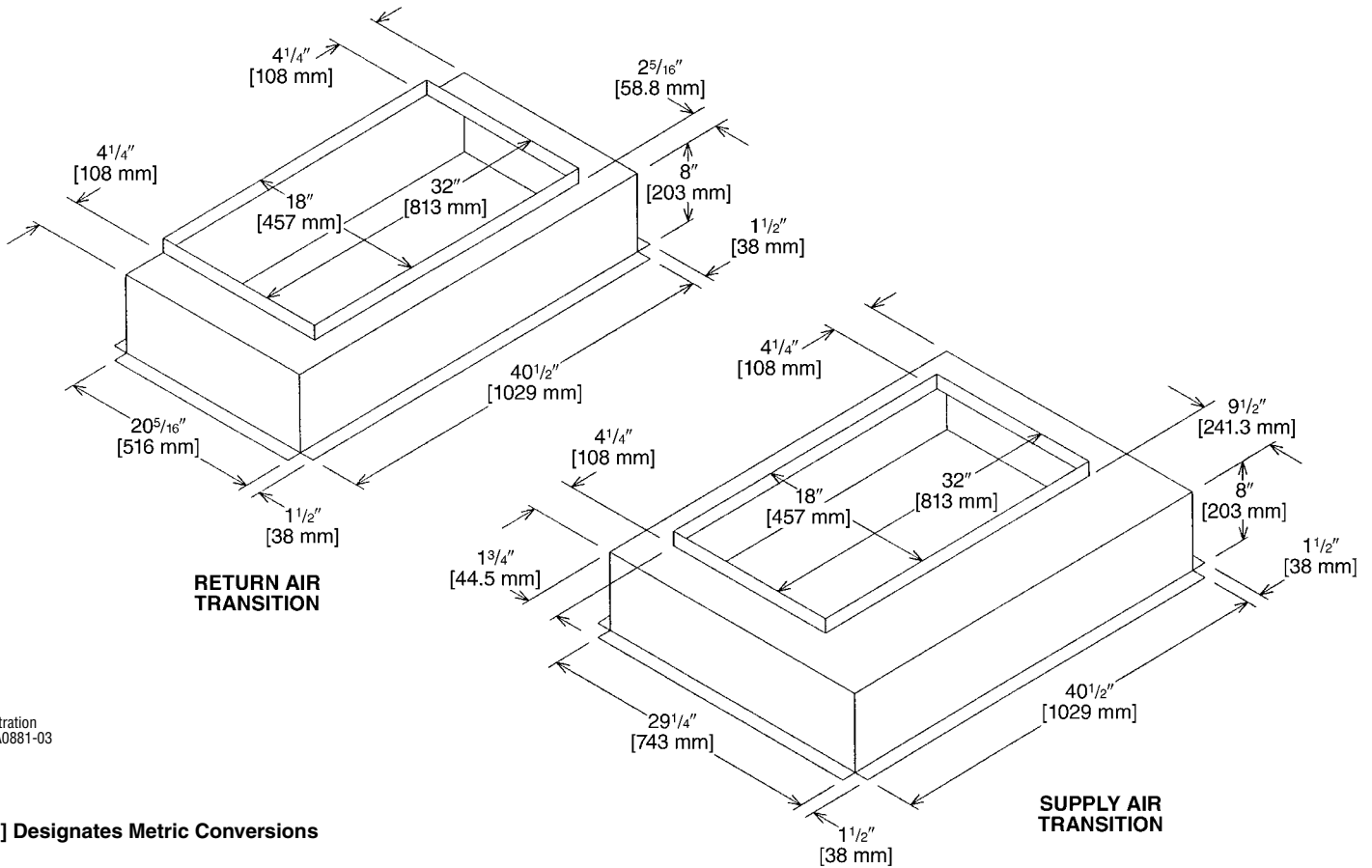

Illustration
ST-A0881-03

[] Designates Metric Conversions

DOWNFLOW TRANSITION DRAWINGS (Cont.)

RXMC-CD04

- Used with RXRN-FA65 or RXRN-FA75 Concentric Diffusers.

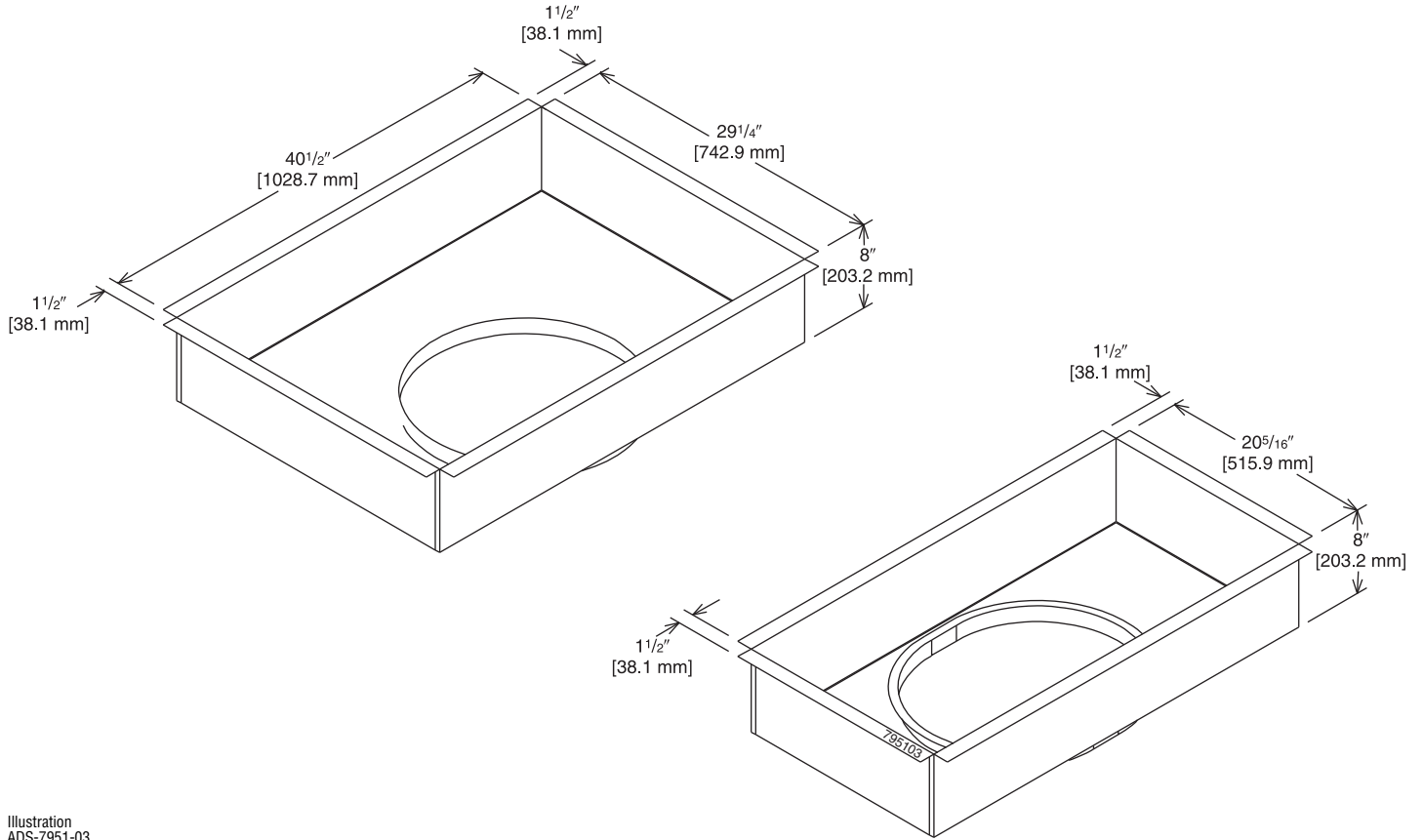

Illustration
ADS-7951-03

CONCENTRIC DIFFUSER—STEP DOWN

RXRN-FA65 (7.5 & 8.5 Ton [26.4 & 29.9 kW] Models)

For Use With Downflow Transition (RXMC-CD04) and 20" [508 mm] Round Supply and Return Ducts

- All aluminum diffuser with aluminum return air eggcrate.
- Built-in anti-sweat gasket.
- Molded fiberglass supports.
- Built-in hanging supports.
- Diffuser box constructed of sheetmetal insulated with 1" [25.4 mm] 1.5 lbs. [.7 kg] duct liner.

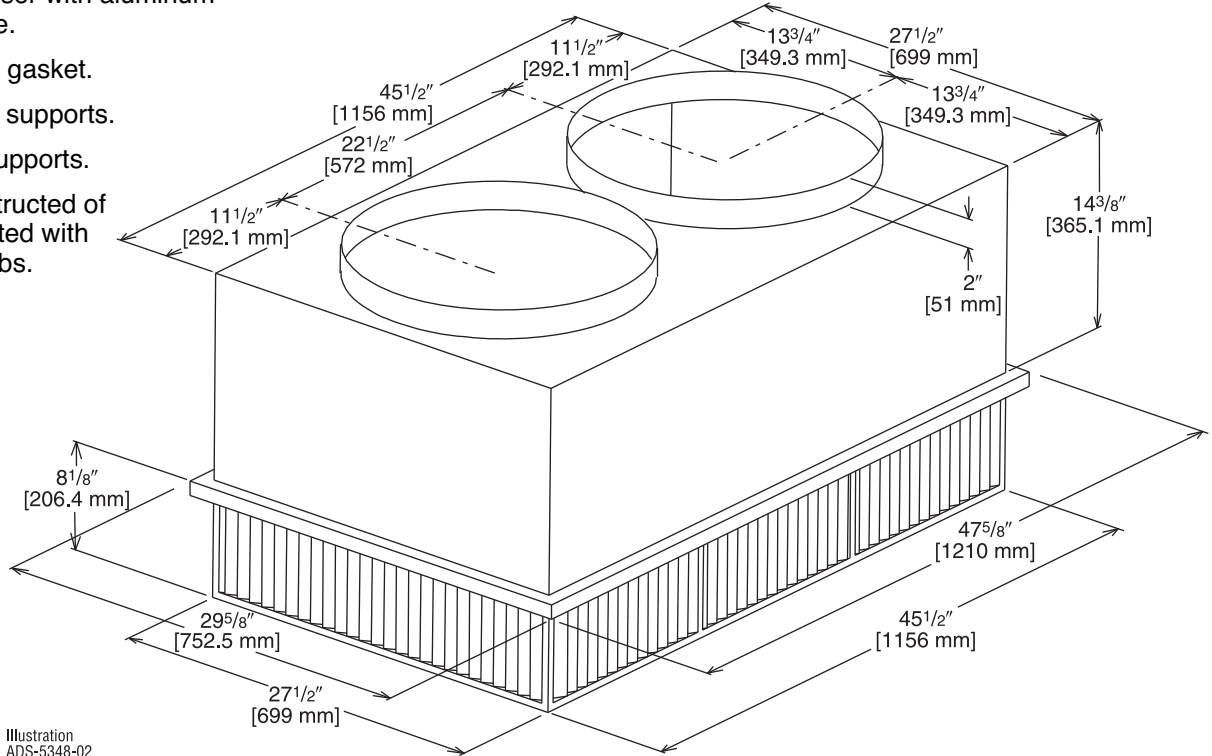

Illustration
ADS-5348-02

ENGINEERING DATA^①

| Model No. | Flow Rate CFM [L/s] | Static Pressure in. w.c. [kPa] | Throw ^{② ③} Feet [m] | Neck Velocity fpm [m/s] | Noise Level ^④ (dbA) |
|-----------|------------------------|-----------------------------------|----------------------------------|----------------------------|-----------------------------------|
| RXRN-FA65 | 2600 [1227] | 0.17 [0.042] | 24-29 [7.3-8.8] | 669 [3.4] | 20 |
| | 2800 [1321] | 0.20 [0.050] | 25-30 [7.6-9.1] | 720 [3.7] | 25 |
| | 3000 [1416] | 0.25 [0.062] | 27-33 [8.2-10.1] | 772 [3.9] | 25 |
| | 3200 [1510] | 0.31 [0.077] | 28-35 [8.5-10.7] | 823 [4.2] | 25 |
| | 3400 [1604] | 0.37 [0.092] | 30-37 [9.1-11.3] | 874 [4.4] | 30 |

NOTES: ① All data is based on the air diffusion council guidelines.

② Throw data is based on 75 FPM Terminal Velocities using isothermal air.

③ Throw is based on diffuser blades being directed in a straight pattern.

④ Actual noise levels may vary due to duct design and do not include transmitted unit noise.

Adequate duct attenuation must be provided to reduce sound output from the unit.

[] Designates Metric Conversions

CONCENTRIC DIFFUSER—STEP DOWN 18" x 28" [457.2 x 711.2 mm]

RXRN-AA61 (8.5 & 10 Ton [29.9 kW & 35.2] Models)

For Use With Downflow Transition (RXMC-CE05)
and 18" x 28" [457.2 x 711.2 mm]
Supply and Return Ducts

- All aluminum diffuser with aluminum return air eggcrate.
- Built-in anti-sweat gasket.
- Molded fiberglass supports.
- Built-in hanging supports.
- Diffuser box constructed of sheetmetal insulated with 1" [25.4 mm] 1.5 lbs. [.7 kg] duct liner.
- Double deflection diffuser with the blades secured by spring steel.

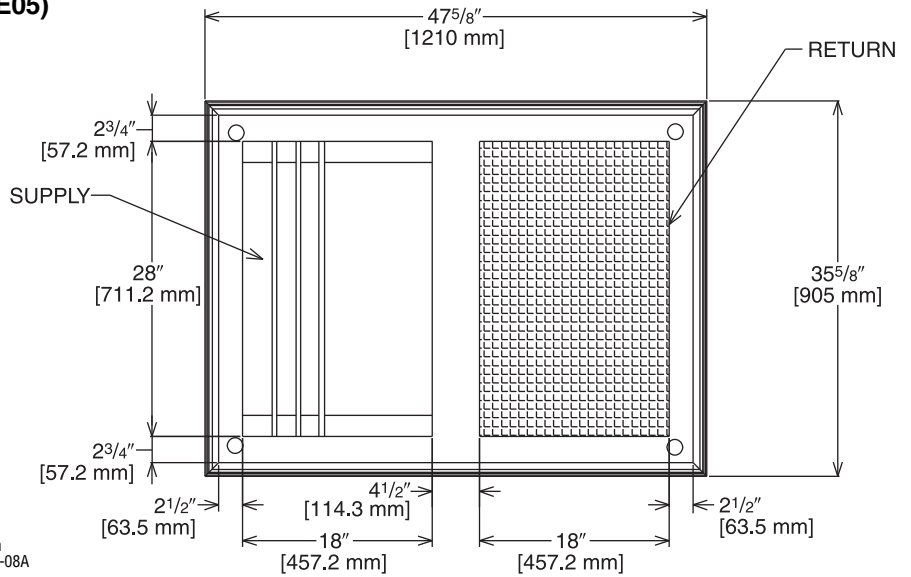

Illustration
ADS-7951-08A

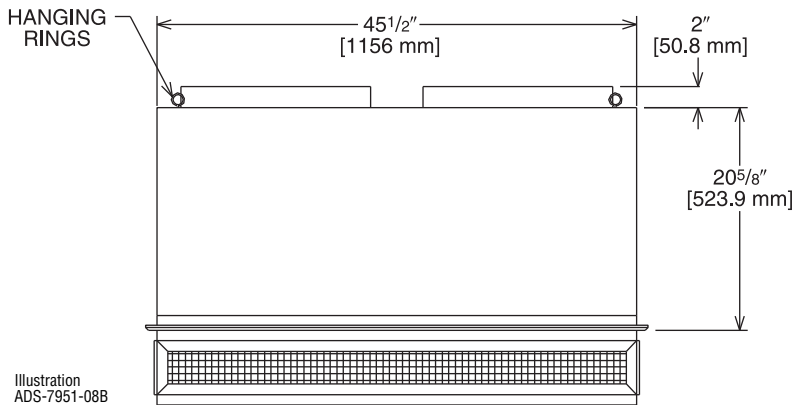

Illustration
ADS-7951-08B

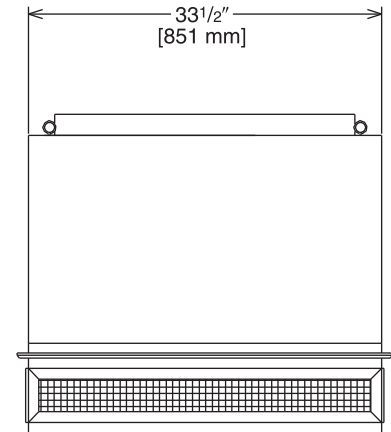

Illustration
ADS-7951-08C

ENGINEERING DATA^①

| Model No. | Flow Rate CFM [L/s] | Static Pressure in w.c. [kPa] | Throw ^{② ③} Feet [m] | Neck Velocity fpm [m/s] | Noise Level ^④ (dB) |
|-----------|------------------------|----------------------------------|----------------------------------|----------------------------|----------------------------------|
| RXRN-AA61 | 3600 [1699] | 0.17 [0.042] | 25-33 [7.6-10.1] | 851 [4.3] | 30 |
| | 3800 [1793] | 0.18 [0.045] | 27-35 [8.2-10.7] | 898 [4.6] | 30 |
| | 4000 [1888] | 0.21 [0.052] | 29-37 [8.8-11.3] | 946 [4.8] | 30 |
| | 4200 [1982] | 0.24 [0.060] | 32-40 [9.8-12.2] | 993 [5.0] | 30 |
| | 4400 [2076] | 0.27 [0.067] | 34-42 [10.4-12.8] | 1040 [5.3] | 30 |

- NOTES: ① All data is based on the air diffusion council guidelines.
 ② Throw data is based on 75 FPM Terminal Velocities using isothermal air.
 ③ Throw is based on diffuser blades being directed in a straight pattern.
 ④ Actual noise levels may vary due to duct design and do not include transmitted unit noise.
 Adequate duct attenuation must be provided to reduce sound output from the unit.

[] Designates Metric Conversions

CONCENTRIC DIFFUSER—STEP DOWN 18" x 32" [457.2 x 813 mm]

RXRN-AA66 (12.5 Ton [44.0 kW] Models)

For Use With Downflow Transition (RXMC-CF06)
and 18" x 32" [457.2 x 813 mm]
Supply and Return Ducts

- All aluminum diffuser with aluminum return air eggcrate.
- Built-in anti-sweat gasket.
- Molded fiberglass supports.
- Built-in hanging supports.
- Diffuser box constructed of sheetmetal insulated with 1" [25.4 mm] 1.5 lbs. [.7 kg] duct liner.
- Double deflection diffuser with the blades secured by spring steel.

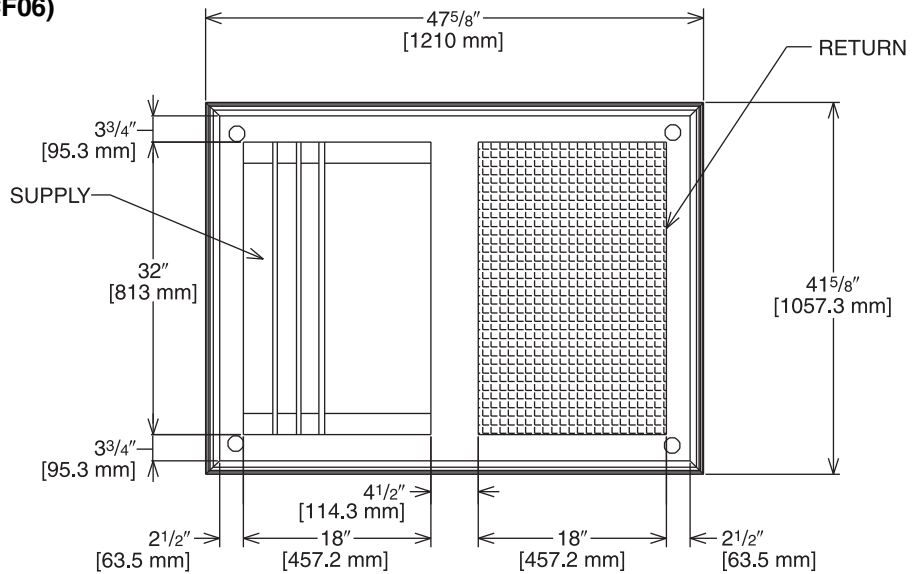

Illustration
ADS-7951-09A

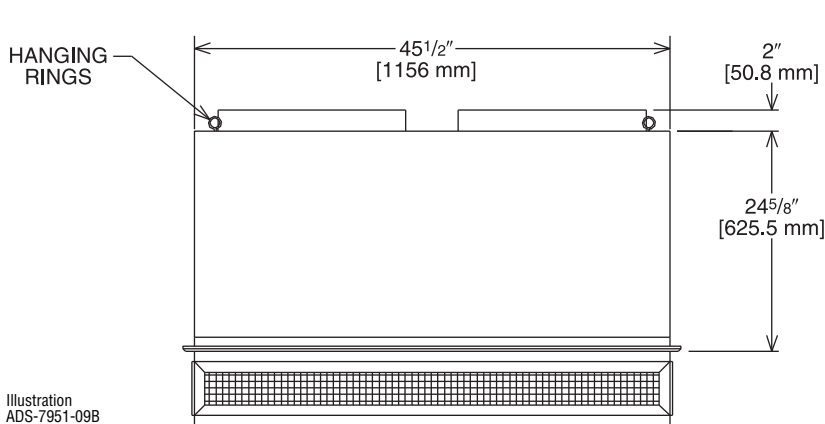

Illustration
ADS-7951-09B

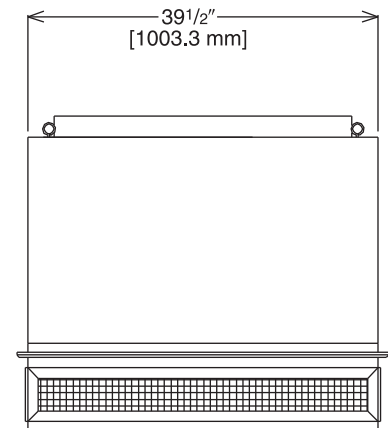

Illustration
ADS-7951-09C

ENGINEERING DATA^①

| Model No. | Flow Rate CFM [L/s] | Static Pressure in w.c. [kPa] | Throw ^{② ③} Feet [m] | Neck Velocity fpm [m/s] | Noise Level ^④ (dba) |
|-----------|------------------------|----------------------------------|----------------------------------|----------------------------|-----------------------------------|
| RXRN-AA66 | 4600 [2171] | 0.31 [0.077] | 26-31 [7.9-9.4] | 841 [4.3] | 30 |
| | 4800 [2265] | 0.32 [0.080] | 27-32 [8.2-9.8] | 878 [4.5] | 30 |
| | 5000 [2359] | 0.34 [0.085] | 28-33 [8.5-10.1] | 915 [4.6] | 30 |
| | 5200 [2454] | 0.36 [0.090] | 28-34 [8.5-10.4] | 951 [4.8] | 30 |
| | 5400 [2548] | 0.39 [0.097] | 29-35 [8.8-10.7] | 988 [6.0] | 30 |

NOTES: ① All data is based on the air diffusion council guidelines.

② Throw data is based on 75 FPM Terminal Velocities using isothermal air.

③ Throw is based on diffuser blades being directed in a straight pattern.

④ Actual noise levels may vary due to duct design and do not include transmitted unit noise.

Adequate duct attenuation must be provided to reduce sound output from the unit.

[] Designates Metric Conversions

FLUSH MOUNT CONCENTRIC DIFFUSER—FLUSH

RXRN-FA75 (7.5 & 8.5 Ton [26.4 & 29.9 kW] Models)

For Use With Downflow Transition (RXMC-CD04)
and 20" [508 mm] Round Supply and Return Ducts

- All aluminum diffuser with aluminum return air eggcrate.
- Built-in anti-sweat gasket.
- Molded fiberglass supports.
- Built-in hanging supports.
- Diffuser box constructed of sheetmetal insulated with 1" [25.4 mm] 1.5 lbs. [.7 kg] duct liner.

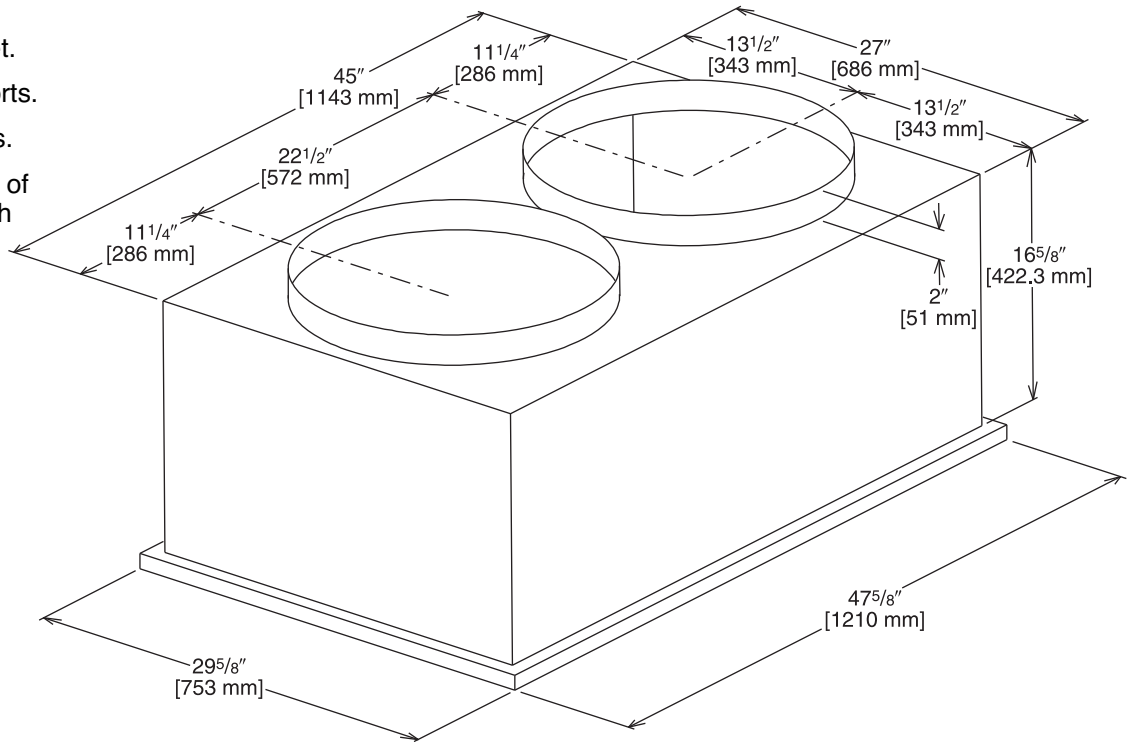

Illustration
ADS-5348-04

ENGINEERING DATA^①

| Model No. | Flow Rate CFM [L/s] | Static Pressure in. w.c. [kPa] | Throw ^{② ③} Feet [m] | Neck Velocity fpm [m/s] | Noise Level ^④ (dbA) |
|-----------|------------------------|-----------------------------------|----------------------------------|----------------------------|-----------------------------------|
| RXRN-FA75 | 2600 [1227] | .17 [0.042] | 19-24 [5.8-7.3] | 663 [3.4] | 30 |
| | 2800 [1321] | .20 [0.050] | 20-28 [6.1-8.5] | 714 [3.6] | 35 |
| | 3000 [1416] | .25 [0.062] | 21-29 [6.4-8.8] | 765 [3.9] | 35 |
| | 3200 [1510] | .31 [0.077] | 22-29 [6.7-8.8] | 816 [4.1] | 40 |
| | 3400 [1604] | .37 [0.092] | 22-30 [6.7-9.1] | 867 [4.4] | 40 |

- NOTES: ① All data is based on the air diffusion council guidelines.
 ② Throw data is based on 75 FPM Terminal Velocities using isothermal air.
 ③ Throw is based on diffuser blades being directed in a straight pattern.
 ④ Actual noise levels may vary due to duct design and do not include transmitted unit noise.
 Adequate duct attenuation must be provided to reduce sound output from the unit.

[] Designates Metric Conversions

CONCENTRIC DIFFUSER—FLUSH and 18" x 28" [457.2 x 711.2 mm]

RXRN-AA71 (8.5 & 10 Ton [29.9 & 35.2] Models)

For Use With Downflow Transition (RXMC-CE05)
and 18" x 28" [457.2 x 711.2 mm]
Supply and Return Ducts

- All aluminum diffuser with aluminum return air eggcrate.
- Built-in anti-sweat gasket.
- Molded fiberglass supports.
- Built-in hanging supports.
- Diffuser box constructed of sheetmetal insulated with 1" [25.4 mm] 1.5 lbs. [.7 kg] duct liner.

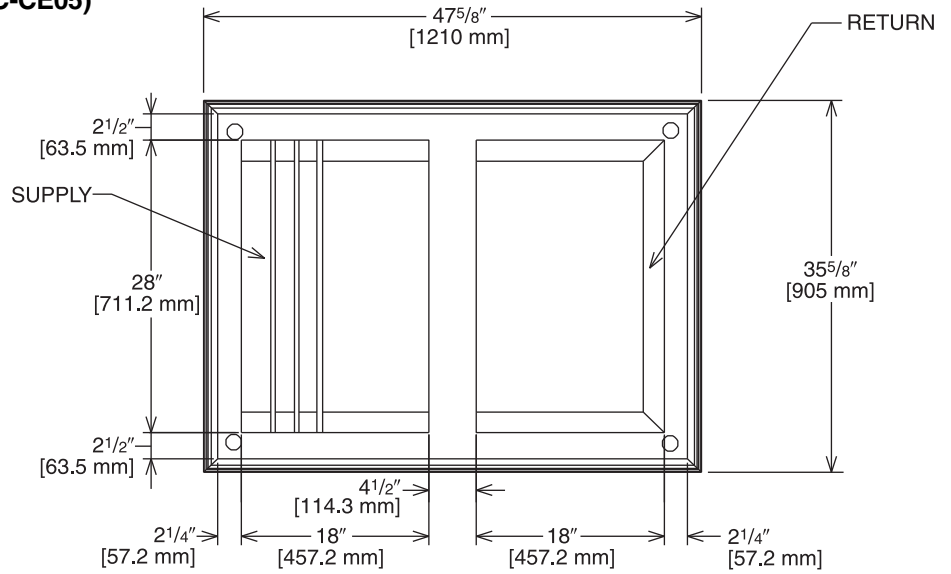

Illustration
ADS-7951-06A

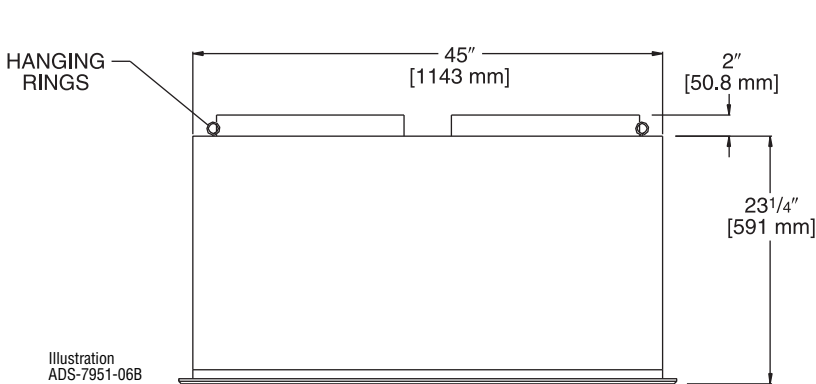

Illustration
ADS-7951-06B

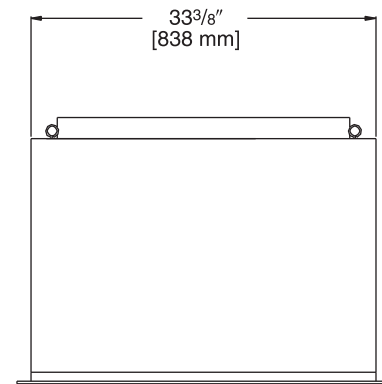

Illustration
ADS-7951-06C

ENGINEERING DATA^①

| Model No. | Flow Rate CFM [L/s] | Static Pressure in w.c. [kPa] | Throw ^{② ③} Feet [m] | Neck Velocity fpm [m/s] | Noise Level ^④ (dbA) |
|-----------|------------------------|----------------------------------|----------------------------------|----------------------------|-----------------------------------|
| RXRN-AA71 | 3600 [1699] | 0.17 [0.042] | 22-29 [6.7-8.8] | 844 [4.3] | 35 |
| | 3800 [1793] | 0.18 [0.045] | 22-30 [6.7-9.1] | 891 [4.5] | 40 |
| | 4000 [1888] | 0.21 [0.052] | 24-33 [7.3-10.1] | 938 [4.8] | 40 |
| | 4200 [1982] | 0.24 [0.060] | 26-35 [7.9-10.7] | 985 [5.0] | 40 |
| | 4400 [2076] | 0.27 [0.067] | 28-37 [8.5-11.3] | 1032 [5.2] | 40 |

NOTES: ① All data is based on the air diffusion council guidelines.

② Throw data is based on 75 FPM Terminal Velocities using isothermal air.

③ Throw is based on diffuser blades being directed in a straight pattern.

④ Actual noise levels may vary due to duct design and do not include transmitted unit noise.

Adequate duct attenuation must be provided to reduce sound output from the unit.

[] Designates Metric Conversions

CONCENTRIC DIFFUSER—FLUSH 18" x 32" [457.2 x 813 mm]

RXRN-AA76 (12.5 Ton [44.0 kW] Models)

For Use With Downflow Transition (RXMC-CF06)
and 18" x 32" [457.2 x 813 mm]
Supply and Return Ducts

- All aluminum diffuser with aluminum return air eggcrate.
- Built-in anti-sweat gasket.
- Molded fiberglass supports.
- Built-in hanging supports.
- Diffuser box constructed of sheetmetal insulated with 1" [25.4 mm] 1.5 lbs. [.7 kg] duct liner.

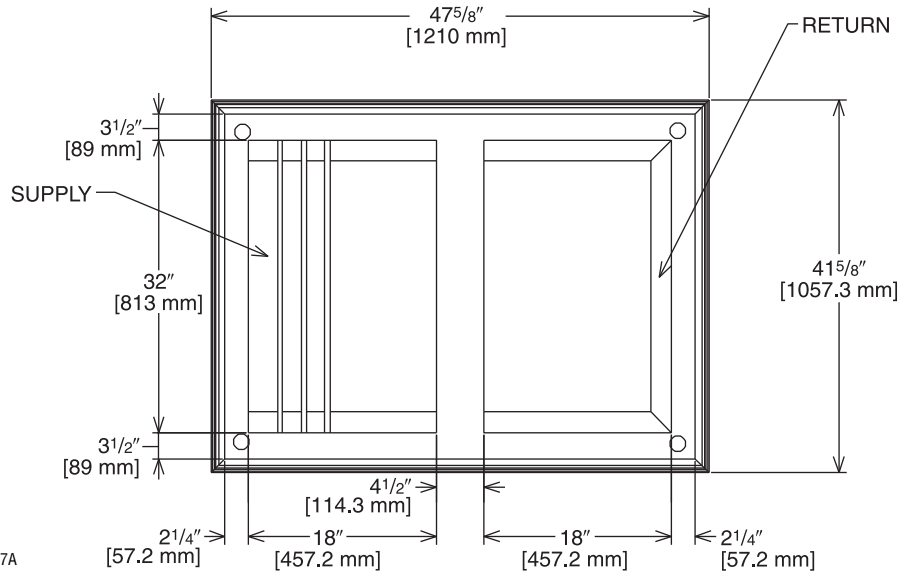

Illustration
ADS-7951-07A

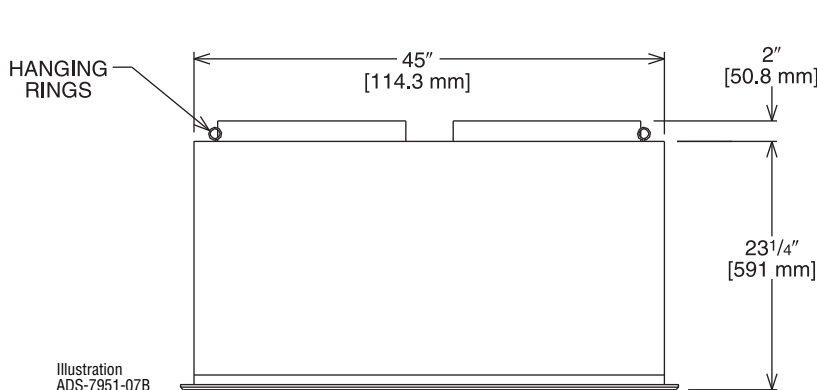

Illustration
ADS-7951-07B

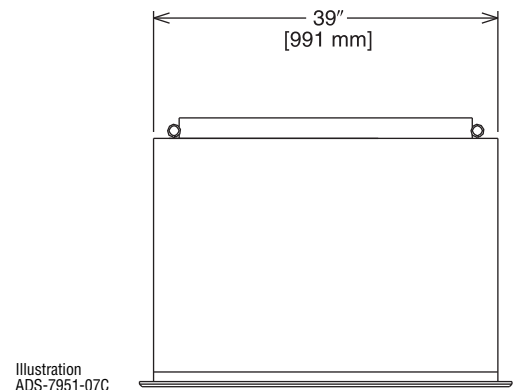

Illustration
ADS-7951-07C

ENGINEERING DATA^①

| Model No. | Flow Rate CFM [L/s] | Static Pressure in w.c. [kPa] | Throw ^{② ③} Feet [m] | Neck Velocity fpm [m/s] | Noise Level ^④ (dbA) |
|-----------|------------------------|----------------------------------|----------------------------------|----------------------------|-----------------------------------|
| RXRN-AA76 | 4600 [2171] | 0.31 [0.077] | 25-34 [7.6-10.4] | 922 [4.7] | 40 |
| | 4800 [2265] | 0.32 [0.080] | 26-35 [7.9-10.7] | 962 [4.9] | 40 |
| | 5000 [2359] | 0.34 [0.085] | 27-36 [8.2-11.0] | 1002 [5.1] | 40 |
| | 5200 [2454] | 0.36 [0.090] | 30-39 [9.1-11.9] | 1043 [5.3] | 45 |
| | 5400 [2548] | 0.39 [0.097] | 32-41 [9.8-12.5] | 1083 [5.5] | 45 |

NOTES: ① All data is based on the air diffusion council guidelines.

② Throw data is based on 75 FPM Terminal Velocities using isothermal air.

③ Throw is based on diffuser blades being directed in a straight pattern.

④ Actual noise levels may vary due to duct design and do not include transmitted unit noise.
Adequate duct attenuation must be provided to reduce sound output from the unit.

[] Designates Metric Conversions

GUIDE SPECIFICATIONS – RLNL-C072 thru C150

You may copy this document directly into your building specification. This specification is written to comply with the 2004 version of the “master format” as published by the Construction Specification Institute. www.csinet.org.

ELECTRIC HEAT PACKAGED ROOFTOP HVAC Guide Specifications

Size Range: 6 to 12.5 Nominal Tons

| <u>Section</u> | <u>Description</u> |
|----------------|--------------------|
|----------------|--------------------|

| | |
|-----------------|---|
| 23 06 80 | Schedules for Decentralized HVAC Equipment |
|-----------------|---|

| | |
|-------------|---|
| 23 06 80.13 | Decentralized Unitary HVAC Equipment Schedule |
|-------------|---|

| | |
|----------------|-----------------------|
| 23 06 80.13.A. | Rooftop unit schedule |
|----------------|-----------------------|

1. Schedule is per the project specification requirements.

| | |
|-----------------|----------------------------------|
| 23 07 16 | HVAC Equipment Insulation |
|-----------------|----------------------------------|

| | |
|-------------|-------------------------------|
| 23 07 16.13 | Decentralized, Rooftop Units: |
|-------------|-------------------------------|

1. Interior cabinet surfaces shall be insulated with a minimum 3/4-in. thick, minimum 1-1/2 lb density, flexible fiberglass insulation bonded with a phenolic binder, with aluminum foil facing on the air side.
2. Insulation and adhesive shall meet NFPA 90A requirements for flame spread and smoke generation.

| | |
|-----------------|---|
| 23 09 13 | Instrumentation and Control Devices for HVAC |
|-----------------|---|

| | |
|-------------|--------------------------|
| 23 09 13.23 | Sensors and Transmitters |
|-------------|--------------------------|

| | |
|----------------|-------------|
| 23 09 13.23.A. | Thermostats |
|----------------|-------------|

1. Thermostat must
 - a. have capability to energize 2 different stages of cooling, and 2 different stages of heating.
 - b. must include capability for occupancy scheduling.

| | |
|-----------------|---|
| 23 09 23 | Direct-digital Control system for HVAC |
|-----------------|---|

| | |
|-------------|-------------------------------|
| 23 09 23.13 | Decentralized, Rooftop Units: |
|-------------|-------------------------------|

| | |
|----------------|------------------|
| 23 09 23.13.A. | RTU-C controller |
|----------------|------------------|

1. Shall be ASHRAE 62-2001 compliant.
2. Shall accept 18-32VAC input power.
3. Shall have an operating temperature range from -40°F (-40°C) to 158°F (70°C), 10% - 95% RH (non-condensing).
4. Controller shall accept the following inputs: space temperature, setpoint adjustment, outdoor air temperature, indoor air quality, outdoor air enthalpy, fire shutdown, return air enthalpy, fan status, remote time clock/door switch.
5. Shall accept a CO₂ sensor in the conditioned space, and be Demand Control Ventilation (DCV) ready.
6. Shall provide the following outputs: Economizer, fan, cooling stage 1, cooling stage 2, heat stage 1, heat stage 2, exhaust, occupied.
7. Unit shall provide surge protection for the controller through a circuit breaker.
8. Shall have a field installed communication card allowing the unit to be Internet capable, and communicate at a Baud rate of 19.2K or faster
9. Shall have an LED display independently showing the status of activity on the communication bus, and processor operation.
10. Shall have either a field installed BACnet® plug-in communication card which includes an EIA-485 protocol communication port, or a field installed LonWorks™ plug-in communications card.
11. Software upgrades will be accomplished by local download. Software upgrades through chip replacements are not allowed.
12. Shall be shock resistant in all planes to 5G peak, 11ms during operation, and 100G peak, 11ms during storage.
13. Shall be vibration resistant in all planes to 1.5G @ 20-300 Hz.
14. Shall support a bus length of 4000 ft max, 60 devices per 1000 ft section, and 1 RS-485 repeater per 1000 ft sections.

| | |
|-----------------------|--|
| 23 09 23.13.B. | Open protocol, direct digital controller: |
|-----------------------|--|

1. Shall be ASHRAE 62-2001 compliant.
2. Shall accept 18-30VAC, 50-60Hz, and consumer 15VA or less power.
3. Shall have an operating temperature range from -40°F (-40°C) to 130°F (54°C), 10% - 90% RH (non-condensing).
4. Shall have either a field installed BACnet® plug-in communication card which includes an EIA-485 protocol communication port, or a field installed LonWorks™ plug-in communications card.
5. The BACnet® plug in communication card shall include built-in protocol for BACNET (MS/TP and PTP modes)
6. The LonWorks™ plug in communication card shall include the Echelon processor required for all Lon applications.
7. Shall allow access of up to 62 network variables (SNVT). Shall be compatible with all open controllers
8. Baud rate Controller shall be selectable through the EIA-485 protocol communication port.
9. Shall have an LED display independently showing the status of serial communication, running, errors, power, all digital outputs, and all analog inputs.
10. Shall accept the following inputs: space temperature, setpoint adjustment, outdoor air temperature, indoor air quality, outdoor air enthalpy, compressor lock-out, fire shutdown, enthalpy switch, and fan status/filter status/ humidity/ remote occupancy.
11. Shall provide the following outputs: economizer, fan, cooling stage 1, cooling stage 2, heat stage 1, heat stage 2, exhaust.
12. Software upgrades will be accomplished by either local or remote download. No software upgrades through chip replacements are allowed.

23 09 33 Electric and Electronic Control System for HVAC

23 09 33.13 Decentralized, Rooftop Units:

23 09 33.13.A. General:

1. Shall be complete with self-contained low-voltage control circuit protected by a resettable circuit breaker on the 24-v transformer side. Transformer shall have 100VA capabilities.
2. Shall utilize color-coded wiring.
3. Shall include a central control terminal board to conveniently and safely provide connection points for vital control functions such as: smoke detectors, phase monitor, economizer, thermostat, DDC control options, loss of charge, freeze sensor, high pressure switches.
4. Unit shall include a minimum of one 10-pin screw terminal connection board for connection of control wiring.

23 09 33.23.B. Safeties:

1. Compressor over-temperature, over current.
2. Loss of charge switch.
 - a. Units with 2 compressors shall have different colored wires for the circuit 1 and circuit 2 low and high pressure switches.
 - b. Loss of charge switch shall use different color wire than the high pressure switch. The purpose is to assist the installer and service technician to correctly wire and or troubleshoot the rooftop unit.
 - c. Loss of charge switch shall have a different sized connector than the high pressure switch. They shall physically prevent the cross-wiring of the safety switches between the high and low pressure side of the system.
3. High-pressure switch.
 - a. Units with 2 compressors shall have different colored wires for the circuit 1 and circuit 2 low and high pressure switches.
 - b. High pressure switch shall use different color wire than the low pressure switch. The purpose is to assist the installer and service person to correctly wire and or troubleshoot the rooftop unit.
 - c. High pressure switch shall have a different sized connector than the loss of charge switch. They shall physically prevent the cross-wiring of the safety switches between the high and low pressure side of the system.
4. Freeze protection sensor, evaporator coil.
5. Automatic reset, motor thermal overload protector.

23 09 93 Sequence of Operations for HVAC Controls

23 09 93.13 Decentralized, Rooftop Units:

23 09 93.13 INSERT SEQUENCE OF OPERATION

23 40 13 Panel Air Filters

23 40 13.13 Decentralized, Rooftop Units:

23 40 13.13.A. Standard filter section shall

1. Shall consist of factory-installed, low velocity, throwaway 2-in. thick fiberglass filters of commercially available sizes.
2. Filters shall be accessible through an access panel as described in the unit cabinet section of this specification (23 81 19.13.H).

23 81 19 Self-Contained Air Conditioners

23 81 19.13 Small-Capacity Self-Contained Air Conditioners

23 81 19.13.A. General

1. Outdoor, rooftop mounted, electrically controlled, heating and cooling unit utilizing a(n) hermetic scroll compressor(s) for cooling duty and heat pump for heating duty.
2. Factory assembled, single-piece heating and cooling rooftop unit. Contained within the unit enclosure shall be all factory wiring, piping, controls, and special features required prior to field start-up.
3. Unit shall use environmentally sound R-410a refrigerant.
4. Unit shall be installed in accordance with the manufacturer's instructions.
5. Unit must be selected and installed in compliance with local, state, and federal codes.

23 81 19.13.B. Quality Assurance

1. Unit meets ASHRAE 90.1-2004 minimum efficiency requirements.
2. 3 phase units are Energy Star qualified.
3. Unit shall be rated in accordance with AHRI Standards 210/240 and 340/360.
4. Unit shall be designed to conform to ASHRAE 15, 2001.
5. Unit shall be UL-tested and certified in accordance with ANSI Z21.47 Standards and UL-listed and certified under Canadian standards as a total package for safety requirements.
6. Insulation and adhesive shall meet NFPA 90A requirements for flame spread and smoke generation.
7. Unit casing shall be capable of withstanding 500-hour salt spray exposure per ASTM B117 (scribed specimen).
8. Unit casing shall be capable of withstanding Federal Test Method Standard No. 141 (Method 6061) 5000-hour salt spray.
9. Unit shall be designed in accordance with ISO 9001:2000, and shall be manufactured in a facility registered by ISO 9001:2000.
10. Roof curb shall be designed to conform to NRCA Standards.
11. Unit shall be subjected to a completely automated run test on the assembly line. The data for each unit will be stored at the factory, and must be available upon request.
12. Unit shall be designed in accordance with UL Standard 1995, including tested to withstand rain.
13. Unit shall be constructed to prevent intrusion of snow and tested to prevent snow intrusion into the control box up to 40 mph.

- 23 81 19.13.C. Delivery, Storage, and Handling
1. Unit shall be stored and handled per manufacturer's recommendations.
 2. Lifted by crane requires either shipping top panel or spreader bars.
 3. Unit shall only be stored or positioned in the upright position.
- 23 81 19.13.E. Project Conditions
1. As specified in the contract.
- 23 81 19.13.F. Operating Characteristics
1. Unit shall be capable of starting and running at 115°F (46°C) ambient outdoor temperature, meeting maximum load criteria of AHRI Standard 210/240 or 340/360 at ± 10% voltage.
 2. Compressor with standard controls shall be capable of operation from 40°F (4°C) , ambient outdoor temperatures. Accessory low ambient kit is necessary if mechanically cooling at ambient temperatures below 40°F (4°C).
 3. Unit shall discharge supply air vertically or horizontally as shown on contract drawings.
 4. Unit shall be factory configured for vertical supply & return configurations.
 5. Unit shall be field convertible from vertical to horizontal configuration.
- 23 81 19.13.G. Electrical Requirements
1. Main power supply voltage, phase, and frequency must match those required by the manufacturer.
- 23 81 19.13.H. Unit Cabinet
1. Unit cabinet shall be constructed of galvanized steel, and shall be bonderized and coated with a baked enamel finish on all externally exposed surfaces.
 2. Unit cabinet exterior paint shall be: film thickness, (dry) 0.003 inches minimum, gloss (per ASTM D523, 60°F): 60, Hardness: H-2H Pencil hardness.
 3. Evaporator fan compartment interior cabinet insulation shall conform to AHRI Standards 210/240 or 340/360 minimum exterior sweat criteria. Interior surfaces shall be insulated with a minimum 3/4-in. thick, 1 lb density, flexible fiberglass insulation, aluminum foil-faced on the air side.
 4. Base of unit shall have locations for thru-the-base electrical connections (factory installed or field installed), standard.
 5. Base Rail
 - a. Unit shall have base rails on all sides.
 - b. Holes shall be provided in the base rails for rigging shackles to facilitate maneuvering and overhead rigging.
 - c. Holes shall be provided in the base rail for moving the rooftop by fork truck.
 - d. Base rail shall be a minimum of 14 gauge thickness.
 6. Condensate pan and connections:
 - a. Shall be a sloped condensate drain pan made of a non-corrosive material.
 - b. Shall comply with ASHRAE Standard 62.
 - c. Shall use a 1" -11 1/2 NPT drain connection, through the side of the drain pan. Connection shall be made per manufacturer's recommendations.
 7. Top panel:
 - a. Indoor section shall be a single piece top panel.
 8. Electrical Connections
 - a. All unit power wiring shall enter unit cabinet at a single, factory-prepared, knockout location.
 - b. Thru-the-base capability
 - (1.) Standard unit shall have a thru-the-base electrical location(s) using a raised, embossed portion of the unit basepan.
 - (2.) No basepan penetration, other than those authorized by the manufacturer, is permitted.
 9. Component access panels (standard)
 - a. Cabinet panels shall be easily removable for servicing.
 - b. Stainless steel metal hinges are standard on all doors.
 - c. Panels covering control box, indoor fan, indoor fan motor, and electric or gas heater components (where applicable), shall have 1/4 turn latches.
- 23 81 19.13.J. Coils
1. Standard Aluminum/Copper Coils: on all models.
 - a. Standard evaporator and condenser coils shall have aluminum lanced plate fins mechanically bonded to seamless internally grooved copper tubes with all joints brazed.
 - b. Evaporator and Condenser coils shall be leak tested to 150 psig, pressure tested to 550 psig, and qualified to UL 1995 burst test at 2,200 psig.
- 23 81 19.13.K. Refrigerant Components
1. Refrigerant circuit shall include the following control, safety, and maintenance features:
 - a. Thermal Expansion Valve (TXV) with venturi type distributor except the 072 model which shall use small orifice refrigerant control expansion device.
 - b. Refrigerant filter drier.
 - c. External service gauge connections to unit suction and discharge lines.

2. Compressors

- a. Unit shall use one fully hermetic, scroll compressor for each independent refrigeration circuit.
- b. Compressor motors shall be cooled by refrigerant gas passing through motor windings.
- d. Compressors shall be internally protected from high discharge temperature conditions.
- e. Compressors shall be protected from an over-temperature and over-amperage conditions by an internal, motor overload device.
- f. Compressor shall be factory mounted on rubber grommets.
- g. Compressor motors shall have internal line break thermal, current overload and high pressure differential protection.
- h. Crankcase heaters shall not be required for normal operating range.

23 81 19.13.L. Filter Section

1. Filters access is specified in the unit cabinet section of this specification.
2. Filters shall be held in place by a sliding filter tray, facilitating easy removal and installation.
3. Shall consist of factory-installed, low velocity, throw-away 2-in. thick fiberglass filters.
4. Filters shall be standard, commercially available sizes.
5. Filter face velocity shall not exceed 365 fpm at nominal airflows.

23 81 19.13.M. Evaporator Fan and Motor

1. Evaporator fan motor:
 - a. Shall have permanently lubricated bearings.
 - b. Shall have inherent automatic-reset thermal overload protection or circuit breaker.
 - c. Shall have a maximum continuous bhp rating for continuous duty operation; no safety factors above that rating shall be required.
2. Belt-driven Evaporator Fan:
 - a. Belt drive shall include an adjustable-pitch motor pulley.
 - b. Shall use sealed, permanently lubricated ball-bearing type.
 - c. Blower fan shall be double-inlet type with forward-curved blades.
 - d. Shall be constructed from steel with a corrosion resistant finish and dynamically balanced.

23 81 19.13.N. Condenser Fans and Motors

1. Condenser fan motors:
 - a. Shall be a totally enclosed motor.
 - b. Shall use permanently lubricated bearings.
 - c. Shall have inherent thermal overload protection with an automatic reset feature.
 - d. Shall use a shaft-down design. Shaft-up designs including those with “rain-slinger devices” shall not be allowed.
2. Condenser Fans:
 - a. Shall be a direct-driven propeller type fan.
 - b. Shall have aluminum blades riveted to corrosion-resistant steel spiders and shall be dynamically balanced.

23 81 19.13.O. Special Features, Options and Accessories

1. Integrated Economizers:
 - a. Integrated, gear-driven parallel modulating blade design type capable of simultaneous economizer and compressor operation.
 - b. Independent modules for vertical or horizontal return configurations shall be available. Vertical return modules shall be available as a factory installed option.
 - c. Damper blades shall be galvanized steel with metal gears. Plastic or composite blades on intake or return shall not be acceptable.
 - d. Shall include all hardware and controls to provide free cooling with outdoor air when temperature and/or humidity are below setpoints.
 - e. Shall be equipped with gear driven dampers for both the outdoor ventilation air and the return air for positive air stream control.
 - f. Shall be capable of introducing up to 100% outdoor air.
 - g. Shall be equipped with a barometric relief damper capable of relieving up to 100% return air.
 - h. Shall be designed to close damper(s) during loss-of-power situations with spring return built into motor.
 - i. An outdoor single enthalpy sensor shall be provided as standard. Outdoor air sensor setpoint shall be adjustable and shall range from the enthalpy equivalent of 63°F @ 50% rh to 73°F @ 50% rh. Additional sensor options shall be available as accessories.
 - j. The economizer controller shall also provide control of an accessory power exhaust unit function. Factory set at 70%, with a range of 0% to 100%.
 - k. The economizer shall maintain minimum airflow into the building during occupied period and provide design ventilation rate for full occupancy. A remote potentiometer may be used to override the damper setpoint.
 - l. Dampers shall be completely closed when the unit is in the unoccupied mode.
 - m. Economizer controller shall accept a 2-10Vdc CO₂ sensor input for IAQ/DCV control. In this mode, dampers shall modulate the outdoor-air damper to provide ventilation based on the sensor input.

- n. Compressor lockout sensor on the unit controller is factory set at 35°F and is adjustable from 30°F (-1°C) to 50°F (10°C) and resets the cooling lockout at 5°F (+2.7°C) above the set point.
 - o. Actuator shall be direct coupled to economizer gear. No linkage arms or control rods shall be acceptable.
 - p. Economizer controller shall provide indications when in free cooling mode, in the DCV mode, or the exhaust fan contact is closed.
 - q. Economizer wire harness will have provision for smoke detector.
2. Two-Position Motorized Damper
- a. Damper shall be a Two-Position Motorized Damper. Damper travel shall be from the full closed position to the field adjustable %-open setpoint.
 - b. Damper shall include adjustable damper travel from 25% to 100% (full open).
 - c. Damper shall include single or dual blade, gear driven dampers and actuator motor.
 - d. Actuator shall be direct coupled to damper gear. No linkage arms or control rods shall be acceptable.
 - e. Damper will admit up to 100% outdoor air for applicable rooftop units.
 - f. Damper shall close upon indoor (evaporator) fan shutoff and/or loss of power.
 - g. The damper actuator shall plug into the rooftop unit's wiring harness plug. No hard wiring shall be required.
 - h. Outside air hood shall include aluminum water entrainment filter
3. Manual damper
- a. Manual damper package shall consist of damper, air inlet screen, and rain hood which can be preset to admit up to 50% outdoor air for year round ventilation.
4. Head Pressure Control Package
- a. Controller shall control coil head pressure by condenser-fan cycling.
5. Condenser Coil Hail Guard Assembly
- a. Shall protect against damage from hail.
 - b. Shall be louvered design.
6. Convenience Outlet:
- a. Non-Powered convenience outlet.
 - (1.) Outlet shall be powered from a separate 115-120v power source.
 - (2.) A transformer shall not be included.
 - (3.) Outlet shall be factory-installed and internally mounted with easily accessible 115-v female receptacle.
 - (4.) Outlet shall include 15 amp GFI receptacles.
 - (5.) Outlet shall be accessible from outside the unit.
7. Fan/Filter Status Switch:
- a. Switch shall provide status of indoor evaporator fan (ON/OFF) or filter (CLEAN/DIRTY).
 - b. Status shall be displayed either over communication bus (when used with direct digital controls) or through the controller LCD display inside the unit control box.
8. Propeller Power Exhaust:
- a. Power exhaust shall be used in conjunction with an integrated economizer.
 - b. Independent modules for vertical or horizontal return configurations shall be available.
 - c. Horizontal power exhaust is shall be mounted in return ductwork.
 - d. Power exhaust shall be controlled by economizer controller operation. Exhaust fans shall be energized when dampers open past the 0-100% adjustable setpoint on the economizer control.
9. Roof Curbs (Vertical):
- a. Full perimeter roof curb with exhaust capability providing separate air streams for energy recovery from the exhaust air without supply air contamination.
 - b. Formed galvanized steel with wood nailer strip and shall be capable of supporting entire unit weight.
 - c. Permits installation and securing of ductwork to curb prior to mounting unit on the curb.
10. High-Static Indoor Fan Motor(s) and Drive(s):
- a. High-static motor(s) and drive(s) shall be factory-installed to provide additional performance range.
11. Outdoor Air Enthalpy Sensor:
- a. The outdoor air enthalpy sensor shall be used to provide single enthalpy control. When used in conjunction with a return air enthalpy sensor, the unit will provide differential enthalpy control. The sensor allows the unit to determine if outside air is suitable for free cooling.
13. Return Air Enthalpy Sensor:
- a. The return air enthalpy sensor shall be used in conjunction with an outdoor air enthalpy sensor to provide differential enthalpy control.
14. Indoor Air Quality (CO₂) Sensor:
- a. Shall be able to provide demand ventilation indoor air quality (IAQ) control.
 - b. The IAQ sensor shall be available in wall mount with LED display. The setpoint shall have adjustment capability.

15. Smoke detectors:

- a. Shall be a Four-Wire Controller and Detector.
- b. Shall be environmental compensated with differential sensing for reliable, stable, and drift-free sensitivity.
- c. Shall use magnet-activated test/reset sensor switches.
- d. Shall have a recessed momentary switch for testing and resetting the detector.
- e. Controller shall include:
 - (1.) One set of normally open alarm initiation contacts for connection to an initiating device circuit on a fire alarm control panel.
 - (2.) Two Form-C auxiliary alarm relays for interface with rooftop unit or other equipment.
 - (3.) One Form-C supervision (trouble) relay to control the operation of the Trouble LED on a remote test/reset station.
 - (4.) Capable of direct connection to two individual detector modules.
 - (5.) Can be wired to up to 14 other duct smoke detectors for multiple fan shutdown applications.

16. Electric Heat:**a. Heating Section**

- (1.) Heater element open coil resistance wire, nickel-chrome alloy, strung through ceramic insulators mounted on metal frame. Coil ends are staked and welded to terminal screw slots.
- (2.) Heater assemblies are provided with integral fusing for protection of internal heater circuits not exceeding 48 amps each. Auto reset thermo limit controls, magnetic heater contactors (24 v coil) and terminal block all mounted in electric heater control box (minimum 18 ga galvanized steel) attached to end of heater assembly.

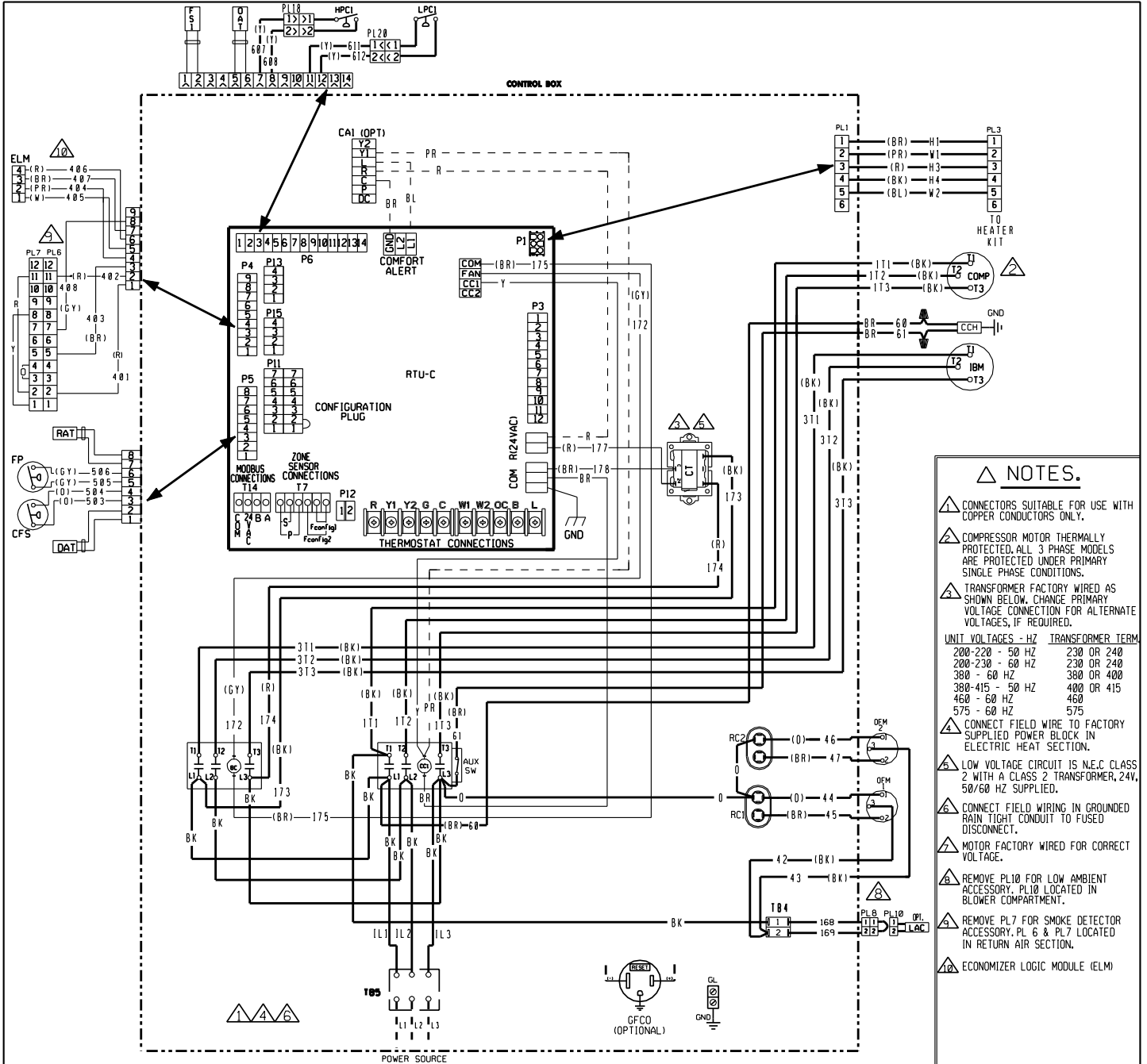

- NOTES.**
- ⚠ CONNECTORS SUITABLE FOR USE WITH COPPER CONDUCTORS ONLY.
 - ⚠ COMPRESSOR MOTOR THERMALLY PROTECTED. ALL 3 PHASE MODELS ARE PROTECTED UNDER PRIMARY SINGLE PHASE CONDITIONS.
 - ⚠ TRANSFORMER FACTORY WIRED AS SHOWN BELOW. CHANGE PRIMARY VOLTAGE CONNECTION FOR ALTERNATE VOLTAGES, IF REQUIRED.
- | UNIT VOLTAGES - HZ | TRANSFORMER TERM |
|--------------------|------------------|
| 200-220 - 50 HZ | 230 OR 240 |
| 200-230 - 60 HZ | 230 OR 240 |
| 380 - 60 HZ | 380 OR 400 |
| 380-415 - 50 HZ | 400 OR 415 |
| 460 - 60 HZ | 460 |
| 575 - 60 HZ | 575 |
- ⚠ CONNECT FIELD WIRE TO FACTORY SUPPLIED POWER BLOCK IN ELECTRIC HEAT SECTION.
 - ⚠ LOW VOLTAGE CIRCUIT IS N.E.C CLASS 2 WITH A CLASS 2 TRANSFORMER, 24V, 50/60 HZ SUPPLIED.
 - ⚠ CONNECT FIELD WIRING IN GROUNDED RAIN TIGHT CONDUIT TO FUSED DISCONNECT.
 - ⚠ MOTOR FACTORY WIRED FOR CORRECT VOLTAGE.
 - ⚠ REMOVE PL10 FOR LOW AMBIENT ACCESSORY. PL10 LOCATED IN BLOWER COMPARTMENT.
 - ⚠ REMOVE PL7 FOR SMOKE DETECTOR ACCESSORY. PL 6 & PL7 LOCATED IN RETURN AIR SECTION.
 - ⚠ ECONOMIZER LOGIC MODULE (ELM)

| COMPONENT CODE | |
|----------------|---------------------------------|
| BC | BLOWER CONTACTOR |
| CA | COMFORT ALERT MODULE |
| CC | COMPRESSOR CONTACTOR |
| CCH | CRANKCASE HEATER |
| CFS | CLOGGED FILTER SWITCH |
| COMP | COMPRESSOR |
| CT | CONTROL TRANSFORMER |
| DAT | DISCHARGE AIR SENSOR |
| DISC | DISCONNECT SWITCH |
| FP | FAN PROVING |
| FS | FREEZE SENSOR |
| GFCO | GROUND FAULT CONVENIENCE OUTLET |
| GL | GROUND LUG |
| GND | GROUND |
| HPC | HIGH PRESSURE CONTROL |
| IBM | INDOOR BLOWER MOTOR BELT DRIVE |
| LAC | LOW AMBIENT COOLING CONTROL |
| LPC | LOW PRESSURE CONTROL |
| OAT | OUTSIDE AIR SENSOR |
| OFM | OUTDOOR FAN MOTOR |
| PL | PLUG |
| RAT | RETURN AIR SENSOR |
| RC | RUN CAPACITOR |
| RTU-C | ROOFTOP UNIT CONTROL |
| TB | TERMINAL BLOCK |
| WIRE NUT | WIRE NUT |

WIRING INFORMATION

LINE VOLTAGE
 -FACTORY STANDARD
 -FACTORY OPTION
 -FIELD INSTALLED

LOW VOLTAGE
 -FACTORY STANDARD
 -FACTORY OPTION
 -FIELD INSTALLED

REPLACEMENT WIRE
 -MUST BE THE SAME SIZE AND TYPE OF INSULATION AS ORIGINAL (105° C MIN.)

WARNING
 -CABINET MUST BE PERMANENTLY GROUNDED AND CONFORM TO I.E.C., N.E.C., C.E.C., AND LOCAL CODES AS APPLICABLE.

| WIRE COLOR CODE | | | |
|-----------------|-------|----|--------|
| BK | BLACK | O | ORANGE |
| BR | BROWN | PR | PURPLE |
| BL | BLUE | R | RED |
| G | GREEN | W | WHITE |
| GY | GRAY | Y | YELLOW |

WIRING DIAGRAM
RLNL-C072/085
 208-230/460/575V 3 PH, 60 HZ.
 PACKAGED A/C W/RTU-C

| | | | | |
|--------|---------|---------|--------------|-----|
| DR. BY | APP. BY | DATE | DWG. NO. | REV |
| MGR | | 4-15-09 | 90-103089-04 | 01 |

DWG. NO. 90-103089-04
 REV 01

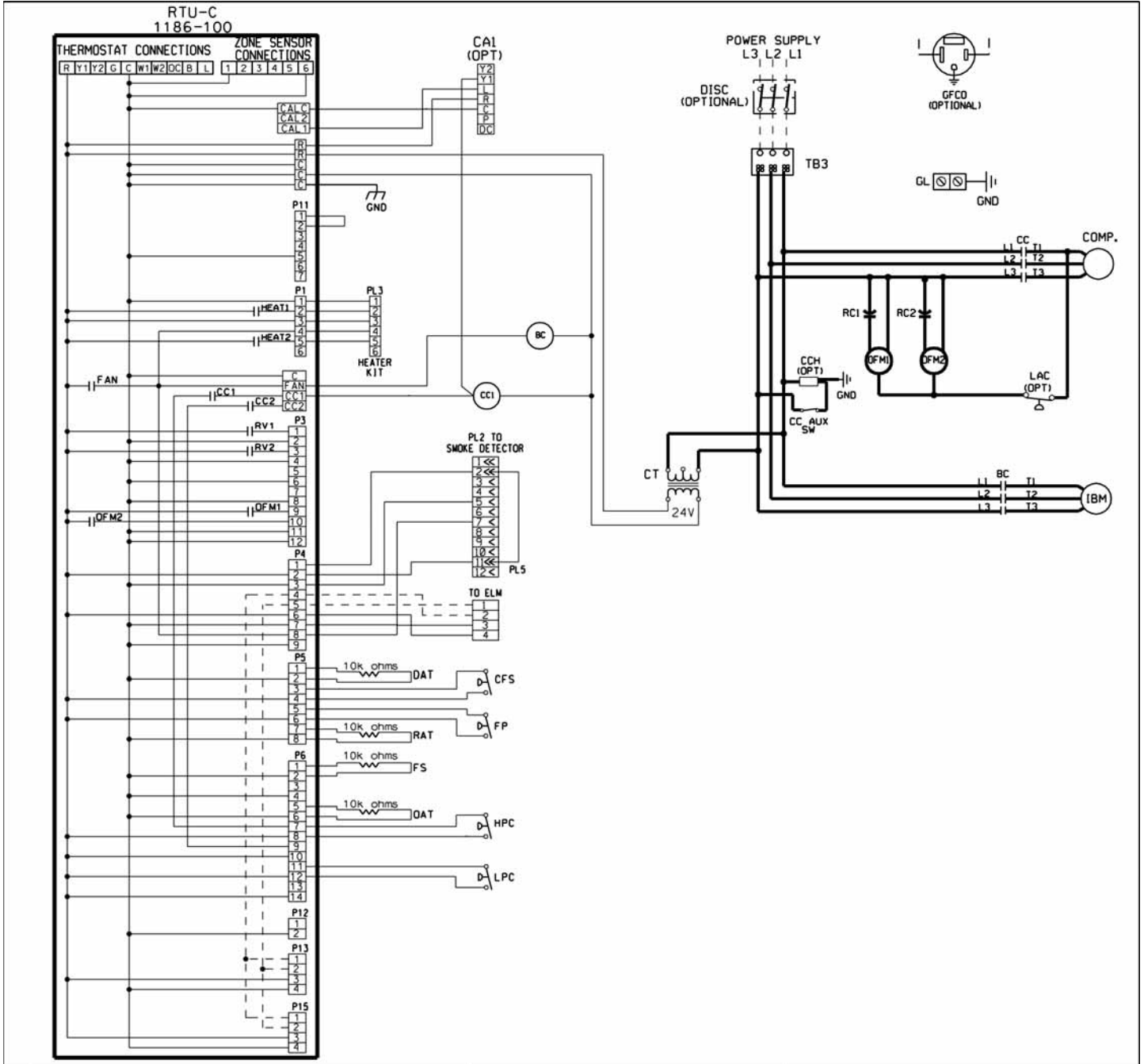

| COMPONENT CODE | | WIRING INFORMATION | | WIRE COLOR CODE | |
|----------------|---------------------------------|--|-------|-----------------|-------|
| BC | BLOWER CONTACTOR | LINE VOLTAGE | ————— | BK | BLACK |
| CA | COMFORT ALERT MODULE | -FACTORY STANDARD | ————— | BR | BROWN |
| CC | COMPRESSOR CONTACTOR | -FACTORY OPTION | | BL | BLUE |
| CC1 | CRANKCASE HEATER | -FIELD INSTALLED | ----- | G | GREEN |
| CFS | CLOGGED FILTER SWITCH | LOW VOLTAGE | ————— | GY | GRAY |
| COMP | COMPRESSOR | -FACTORY STANDARD | ————— | | |
| CT | CONTROL TRANSFORMER | -FACTORY OPTION | | | |
| DISC | DISCONNECT SWITCH | -FIELD INSTALLED | ----- | | |
| FAN | FAN PROVING | REPLACEMENT WIRE | ————— | | |
| FS | FREEZE SENSOR | -MUST BE THE SAME SIZE AND TYPE OF | | | |
| GFCD | GROUND FAULT CONVENIENCE OUTLET | INSULATION AS ORIGINAL (105° C MIN.) | | | |
| GL | GROUND LUG | WARNING | | | |
| GND | GROUND | -CABINET MUST BE PERMANENTLY | | | |
| HPC | HIGH PRESSURE CONTROL | GROUND AND CONFORM TO I.E.C., N.E.C., | | | |
| IBM | INDOOR BLOWER MOTOR BELT DRIVE | C.E.C., AND LOCAL CODES AS APPLICABLE. | | | |
| IFC | INTEGRATED FURNACE CONTROL | | | | |
| LAC | LOW AMBIENT COOLING CONTROL | | | | |
| LC | LIMIT CONTROL | | | | |
| LPC | LOW PRESSURE CONTROL | | | | |
| MAS | MIX AIR SENSOR | | | | |
| OAT | OUTSIDE AIR SENSOR | | | | |
| OFM | OUTDOOR FAN MOTOR | | | | |
| PL | PLUG | | | | |
| RAT | RETURN AIR SENSOR | | | | |
| RC | RUN CAPACITOR | | | | |
| SCC | SPACE COMFORT CONTROL | | | | |
| SE | SPARK ELECTRODE | | | | |
| TB | TERMINAL BLOCK | | | | |
| WIRE NUT | WIRE NUT | | | | |

WIRING SCHEMATIC
RLNL-C072/085
 208-230/460/575V 3 PH, 60 HZ.
 PACKAGED A/C

| | | | | |
|--------|---------|---------|--------------|-----|
| DR. BY | APP. BY | DATE | DWG. NO. | REV |
| MGR | | 7-16-09 | 90-103246-04 | 00 |

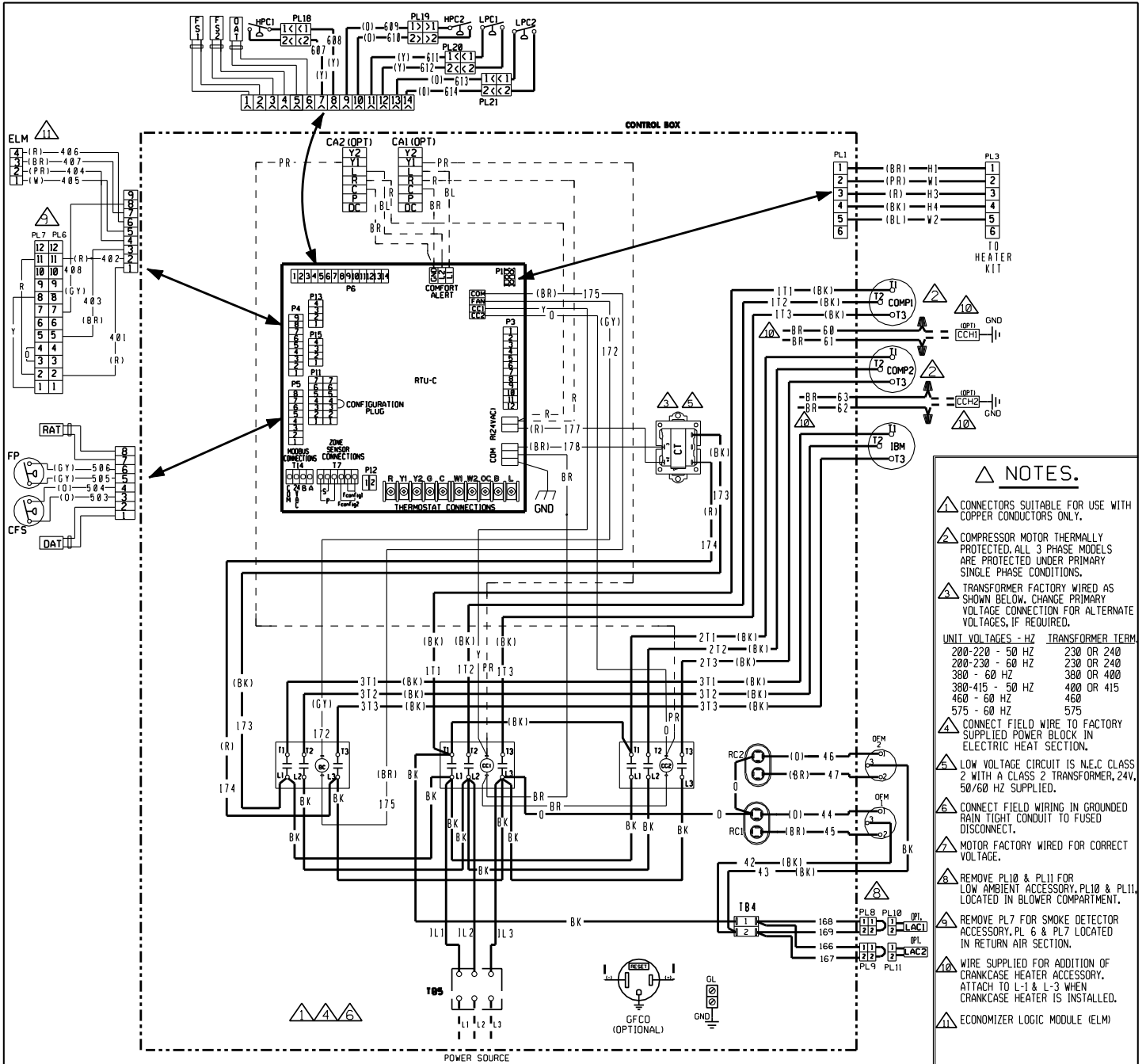

- NOTES.**
- △ CONNECTORS SUITABLE FOR USE WITH COPPER CONDUCTORS ONLY.
 - △ COMPRESSOR MOTOR THERMALLY PROTECTED. ALL 3 PHASE MODELS ARE PROTECTED UNDER PRIMARY SINGLE PHASE CONDITIONS.
 - △ TRANSFORMER FACTORY WIRED AS SHOWN BELOW. CHANGE PRIMARY VOLTAGE CONNECTION FOR ALTERNATE VOLTAGES, IF REQUIRED.
- | UNIT VOLTAGES - HZ | TRANSFORMER TERM |
|--------------------|------------------|
| 200-220 - 50 HZ | 230 OR 240 |
| 200-230 - 60 HZ | 230 OR 240 |
| 380 - 60 HZ | 380 OR 400 |
| 380-415 - 50 HZ | 400 OR 415 |
| 460 - 60 HZ | 460 |
| 575 - 60 HZ | 575 |
- △ CONNECT FIELD WIRE TO FACTORY SUPPLIED POWER BLOCK IN ELECTRIC HEAT SECTION.
 - △ LOW VOLTAGE CIRCUIT IS N.E.C CLASS 2 WITH A CLASS 2 TRANSFORMER, 24V, 50/60 HZ SUPPLIED.
 - △ CONNECT FIELD WIRING IN GROUNDED RAIN TIGHT CONDUIT TO FUSED DISCONNECT.
 - △ MOTOR FACTORY WIRED FOR CORRECT VOLTAGE.
 - △ REMOVE PL10 & PL11 FOR LOW AMBIENT ACCESSORY. PL10 & PL11 LOCATED IN BLOWER COMPARTMENT.
 - △ REMOVE PL7 FOR SMOKE DETECTOR ACCESSORY. PL 6 & PL7 LOCATED IN RETURN AIR SECTION.
 - △ WIRE SUPPLIED FOR ADDITION OF CRANKCASE HEATER ACCESSORY. ATTACH TO L-1 & L-3 WHEN CRANKCASE HEATER IS INSTALLED.
 - △ ECONOMIZER LOGIC MODULE (ELM)

| COMPONENT CODE | WIRING INFORMATION | WIRE COLOR CODE |
|---|--|--|
| BC BLOWER CONTACTOR CA COMFORT ALERT MODULE CC COMPRESSOR CONTACTOR CCH CRANKCASE HEATER CFS CLOGGED FILTER SWITCH COMP COMPRESSOR CT CONTROL TRANSFORMER DAT DISCHARGE AIR SENSOR DISC DISCONNECT SWITCH FP FAN PROVING FS FREEZE SENSOR GFCD GROUND FAULT CONVENIENCE OUTLET GL GROUND LUG GND GROUND HPC HIGH PRESSURE CONTROL IBM INDOOR BLOWER MOTOR BELT DRIVE | LINE VOLTAGE -FACTORY STANDARD -FACTORY OPTION -FIELD INSTALLED LOW VOLTAGE -FACTORY STANDARD -FACTORY OPTION -FIELD INSTALLED REPLACEMENT WIRE -MUST BE THE SAME SIZE AND TYPE OF INSULATION AS ORIGINAL (105° C MIN.) WARNING -CABINET MUST BE PERMANENTLY GROUNDED AND CONFORM TO I.E.C., N.E.C., C.E.C., AND LOCAL CODES AS APPLICABLE. | BK BLACK BR BROWN BL BLUE G GREEN GY GRAY O ORANGE PR PURPLE R RED W WHITE Y YELLOW |
| LAC LOW AMBIENT COOLING CONTROL LPC LOW PRESSURE CONTROL OAT OUTSIDE AIR SENSOR OFM OUTDOOR FAN MOTOR PL PLUG RAT RETURN AIR SENSOR RC RUN CAPACITOR RTU-C ROOFTOP UNIT CONTROL TB TERMINAL BLOCK WIRE NUT | | |

WIRING DIAGRAM
RLNL-C090/102/120/150
 208-230/460/575V 3 PH, 60 HZ.
 PACKAGED A/C W/RTU-C

| | | | | |
|--------|---------|---------|--------------|-----|
| DR. BY | APP. BY | DATE | DWG. NO. | REV |
| MGR | | 4-15-09 | 90-103089-03 | 02 |

DWG. NO. 90-103089-03
 REV 02

BEFORE PURCHASING THIS APPLIANCE, READ IMPORTANT ENERGY COST AND EFFICIENCY INFORMATION AVAILABLE FROM YOUR RETAILER.

GENERAL TERMS OF LIMITED WARRANTY

Ruud will furnish a replacement for any part of this product which fails in normal use and service within the applicable periods stated, in accordance with the terms of the limited warranty.

For Complete Details of the Limited Warranty, Including Applicable Terms and Conditions, See Your Local Installer or Contact the Manufacturer for a Copy.

CompressorFive (5) Years
Electric Resistance Heater ElementsFive (5) Years
*Any Other Part.....One (1) Year

***All other parts and components carry a limited warranty of five years, provided they are single-phase products installed in a residential application.**

Before proceeding with installation, refer to installation instructions packaged with each model, as well as complying with all Federal, State, Provincial, and Local codes, regulations, and practices.

**Ruud Heating,
Cooling and
Water Heating**

P.O. Box 17010, Fort Smith, AR 72917



"In keeping with its policy of continuous progress and product improvement, Ruud reserves the right to make changes without notice."