



Featuring
Earth-Friendly
R-410A Refrigerant

R-410A
earth friendly refrigerant



13PJL SERIES

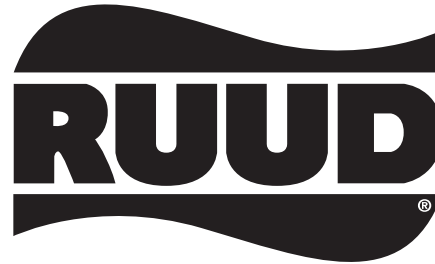
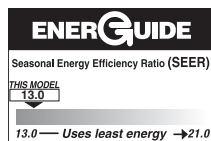

13 SEER HEAT PUMPS

Features

- Coils constructed with copper tubing and enhanced aluminum fins.
- Includes factory installed low pressure control.
- Strong, attractive cabinet—louvered design protects the coil from damage.
- Expansion Valves with Internal Check Valve—Provides for quieter refrigerant metering.
- Demand Defrost Control
- Non-Cycling Reversing Valve
- Hot Gas Muffler
- Service Valves
- Grille/motor mount for quiet fan operation.
- Easily accessible control box.
- Bi-Directional Filter Drier (shipped – not installed)
- Certified and rated under A.R.I. Standard 240.
- U.L listed.

Accessories/Options

- Low Ambient Control (Model No. RXAD-A08)
 - Outdoor Thermostats (Model No. RXPT-A01, A02, A03 or A04)
 - Heat Pump Monitor (Model No. RXPM-B01)
 - Thermostats and Subbases (Available through the PROSTOCK® department)
 - Compressor Time Delay Control (Model No. RXMD-B01)
 - Blower Time Delay Control (Model No. RXMD-C04) RXMD-C04 is not required if the outdoor unit is matched with a Ruud Value Series furnace or air handler, or if the furnace or air handler used has a blower off time delay built-in.
 - Sound Enclosure*
 - High Pressure Control (Model No. RXAB-A07)
 - Start Components*
- *Available through the PROSTOCK® department.

Applications

Ruud Value Series remote heat pumps offer comfort and dependability for single, multi-family and light commercial applications.

Model Identification Number

| | | | | | | |
|-----------|--------------------------|----------|------------|--|-----------------------|-------------------|
| 13 | P | J | L | 18 | A | 01 |
| 13 SEER | P = HEAT PUMP | VOLTAGE | L = R-410A | NOMINAL COOLING CAPACITY | CABINET | RUUD VALUE SERIES |
| | J = 208-230 SINGLE PHASE | | | 18 = 18,000 BTU/HR [5.28 kW] 24 = 24,000 BTU/HR [7.03 kW] 30 = 30,000 BTU/HR [8.79 kW] 36 = 36,000 BTU/HR [10.55 kW] 42 = 42,000 BTU/HR [12.31 kW] 48 = 48,000 BTU/HR [14.07 kW] 60 = 60,000 BTU/HR [17.58 kW] | A = FULL METAL JACKET | |

Performance Data ARI Standard Conditions

Note: Only these combinations of indoor/outdoor units are approved and any other combinations should not be used.

| Model Numbers | | ARI Cooling Performance | | | | | | | ARI Htg. Performance (70°F [21.0°C] Indoor) | | | | |
|---------------|-------------------------------|---|--------------------------------|---------------------------|----------------------|-----------------------|-----|-------------|--|------------------|---|--------------|--------------------|
| | | 80°F [26.5°C] DB/67°F [19.5°C] WB Indoor Air 95°F [35.0°C] DB Outdoor Air | | | | | | | Outdoor Air 47°F DB/43°F WB [8.5°C/6.0°C] DOE High Temp. | | Outdoor Air 17°F DB/15°F WB [-8.5°C/-9.5°C] DOE Low Temp. | | DOE Region IV HSPF |
| | | Outdoor Unit 13PJL | Indoor Coil and/or Air Handler | Total Capacity BTU/H [kW] | Net Sens. BTU/H [kW] | Net Latent BTU/H [kW] | EER | SEER | Snd. Rate dB | Indoor CFM [L/s] | BTU/H [kW] | COP | |
| Rev. 3/31/09 | RHSL-HM1817 (RCSL-H*2417A*) ① | | | | | | | | | | 18,200 [5.3] | 13,100 [3.8] | |
| 18 | RCFL-H*2414A* | 18,100 [5.3] | 12,950 [3.8] | 5,150 [1.5] | 11.10 | 13.00 | 76 | 600 [283] | 17,000 [5.0] | 3.36 | 8,800 [2.6] | 2.08 | 7.70 |
| | RCFL-H*2417A* | 18,100 [5.3] | 12,950 [3.8] | 5,150 [1.5] | 11.10 | 13.00 | 76 | 600 [283] | 17,000 [5.0] | 3.36 | 8,800 [2.6] | 2.08 | 7.70 |
| | RBHP-17 (RCHL-24A2) | 17,800 [5.2] | 12,900 [3.8] | 4,900 [1.4] | 12.00 | 14.00 | 76 | 600 [283] | 16,500 [4.8] | 3.64 | 9,100 [2.7] | 2.44 | 8.20 |
| | RHLL-HM2417 (RCSL-H*2417A*) | 18,900 [5.5] | 13,750 [4.0] | 5,150 [1.5] | 12.00 | 14.00 | 76 | 615 [290] | 16,500 [4.8] | 3.62 | 8,300 [2.4] | 2.22 | 8.20 |
| | RHSL-HM2417 (RCSL-H*2417A*) ① | 24,200 [7.1] | 17,050 [5.0] | 7,150 [2.1] | 10.90 | 13.00 | 74 | 800 [378] | 22,800 [6.7] | 3.50 | 13,600 [4.0] | 2.24 | 7.70 |
| 24 | RCFL-H*2414A* | 24,200 [7.1] | 17,050 [5.0] | 7,150 [2.1] | 10.75 | 13.00 | 74 | 800 [378] | 22,800 [6.7] | 3.44 | 13,800 [4.0] | 2.22 | 7.70 |
| | RCFL-H*2417A* | 24,200 [7.1] | 17,050 [5.0] | 7,150 [2.1] | 10.75 | 13.00 | 74 | 800 [378] | 22,800 [6.7] | 3.44 | 13,800 [4.0] | 2.22 | 7.70 |
| | RBHP-17 (RCHL-24A2) | 22,400 [6.6] | 15,850 [4.6] | 6,550 [1.9] | 11.00 | 13.00 | 74 | 800 [378] | 22,200 [6.5] | 3.60 | 14,500 [4.2] | 2.54 | 7.70 |
| | RHLL-HM2417 (RCSL-H*2417A*) | 24,800 [7.3] | 17,650 [5.2] | 7,150 [2.1] | 12.00 | 14.00 | 74 | 800 [378] | 22,200 [6.5] | 3.72 | 13,100 [3.8] | 2.36 | 8.20 |
| | RHSL-HM3017 (RCSL-H*3617A*) ① | 28,600 [8.4] | 21,450 [6.3] | 7,150 [2.1] | 11.40 | 13.00 | 73 | 1,000 [472] | 27,800 [8.1] | 3.74 | 15,600 [4.6] | 2.52 | 8.50 |
| 30 | RCFL-H*3617A* | 28,400 [8.3] | 21,250 [6.2] | 7,150 [2.1] | 11.00 | 13.00 | 73 | 1,000 [472] | 27,400 [8.0] | 3.58 | 15,000 [4.4] | 2.36 | 8.00 |
| | RCFL-H*3617C* | 28,400 [8.3] | 21,250 [6.2] | 7,150 [2.1] | 11.00 | 13.00 | 73 | 1,000 [472] | 27,400 [8.0] | 3.58 | 15,000 [4.4] | 2.36 | 8.00 |
| | RCFL-H*3621A* | 28,400 [8.3] | 21,250 [6.2] | 7,150 [2.1] | 11.00 | 13.00 | 73 | 1,000 [472] | 27,400 [8.0] | 3.58 | 15,000 [4.4] | 2.36 | 8.00 |
| | RCFL-H*3621C* | 28,400 [8.3] | 21,250 [6.2] | 7,150 [2.1] | 11.00 | 13.00 | 73 | 1,000 [472] | 27,400 [8.0] | 3.58 | 15,000 [4.4] | 2.36 | 8.00 |
| | RBHP-21 (RCHL-36A1) | 28,600 [8.4] | 21,200 [6.2] | 7,400 [2.2] | 12.00 | 14.00 | 73 | 1,000 [472] | 26,800 [7.9] | 3.82 | 14,500 [4.2] | 2.56 | 9.00 |
| | RHLL-HM3617 (RCSL-H*3617A*) | 28,800 [8.4] | 21,650 [6.3] | 7,150 [2.1] | 12.00 | 14.00 | 73 | 1,000 [472] | 26,800 [7.9] | 3.78 | 14,400 [4.2] | 2.44 | 9.00 |
| | RHLL-HM3617 (RCSL-H*3617C*) | 28,800 [8.4] | 21,650 [6.3] | 7,150 [2.1] | 12.00 | 14.00 | 73 | 1,000 [472] | 26,800 [7.9] | 3.78 | 14,400 [4.2] | 2.44 | 9.00 |
| | RHSL-HM3017 (RCSL-H*3617C*) | 28,600 [8.4] | 21,450 [6.3] | 7,150 [2.1] | 11.40 | 13.00 | 73 | 1,000 [472] | 27,800 [8.1] | 3.74 | 15,600 [4.6] | 2.52 | 8.50 |

① Highest sales volume tested combination required by D.O.E. test procedures.

[] Designates Metric Conversions

Performance Data ARI Standard Conditions (cont.)

Note: Only these combinations of indoor/outdoor units are approved and any other combinations should not be used.

| Model Numbers | | ARI Cooling Performance | | | | | | | ARI Htg. Performance (70°F [21.0°C] Indoor) | | | | | |
|--------------------------------|--------------------------------------|--|-------------------------------|--------------------------------|----------------|-------|--------------------|------------------------|---|------------------|--|-----------------|-----------------------------|------|
| | | 80°F [26.5°C] DB/67°F [19.5°C] WB Indoor Air 95°F [35.0°C] DB Outdoor Air | | | | | | | Outdoor Air 47°F DB/43°F WB [8.5°C/6.0°C] DOE High Temp. | | Outdoor Air 17°F DB/15°F WB [-8.5°C/-9.5°C] DOE Low Temp. | | DOE Region IV HSPF | |
| Outdoor Unit 13PJL | Indoor Coil and/or Air Handler | Total Capacity BTU/H [kW] | Net Sens. BTU/H [kW] | Net Latent BTU/H [kW] | EER | SEER | Snd. Rate dB | Indoor CFM [L/s] | BTU/H [kW] | COP | BTU/H [kW] | COP | | |
| Rev. 3/31/09 | RHSL-HM3617 (RCSL-H*3617A*) ① | 34,400 [10.1] | 25,350 [7.4] | 9,050 [2.7] | 11.10 | 13.00 | 75 | 1,200 [566] | 34,600 [10.1] | 3.44 | 22,600 [6.6] | 2.40 | 8.50 | |
| | RCFL-H*3617A* | 33,400 [9.8] | 24,350 [7.1] | 9,050 [2.7] | 10.95 | 13.00 | 75 | 1,075 [507] | 34,400 [10.1] | 3.46 | 22,400 [6.6] | 2.40 | 8.50 | |
| | RCFL-H*3617C* | 33,400 [9.8] | 24,350 [7.1] | 9,050 [2.7] | 10.95 | 13.00 | 75 | 1,075 [507] | 34,400 [10.1] | 3.46 | 22,400 [6.6] | 2.40 | 8.50 | |
| | RCFL-H*3621A* | 33,400 [9.8] | 24,350 [7.1] | 9,050 [2.7] | 10.95 | 13.00 | 75 | 1,075 [507] | 34,400 [10.1] | 3.46 | 22,400 [6.6] | 2.40 | 8.50 | |
| | RCFL-H*3621C* | 33,400 [9.8] | 24,350 [7.1] | 9,050 [2.7] | 10.95 | 13.00 | 75 | 1,075 [507] | 34,400 [10.1] | 3.46 | 22,400 [6.6] | 2.40 | 8.50 | |
| | 36 | RBHP-21 (RCHL-36A1) | 35,400 [10.4] | 25,650 [7.5] | 9,750 [2.9] | 11.75 | 13.50 | 75 | 1,175 [554] | 36,000 [10.5] | 3.50 | 23,400 [6.9] | 2.36 | 8.20 |
| | | RHLL-HM3617 (RCSL-H*3617A*) | 35,000 [10.3] | 25,950 [7.6] | 9,050 [2.7] | 12.00 | 14.00 | 75 | 1,200 [566] | 34,000 [10.0] | 3.58 | 22,000 [6.4] | 2.46 | 9.00 |
| | | RHLL-HM3617 (RCSL-H*3617C*) | 35,000 [10.3] | 25,950 [7.6] | 9,050 [2.7] | 12.00 | 14.00 | 75 | 1,200 [566] | 34,000 [10.0] | 3.58 | 22,000 [6.4] | 2.46 | 9.00 |
| | | RHSL-HM3617 (RCSL-H*3617C*) | 34,400 [10.1] | 25,350 [7.4] | 9,050 [2.7] | 11.10 | 13.00 | 75 | 1,200 [566] | 34,600 [10.1] | 3.44 | 22,600 [6.6] | 2.40 | 8.50 |
| | | RHSL-HM3621 (RCSL-H*3621A*) | 34,400 [10.1] | 25,350 [7.4] | 9,050 [2.7] | 11.10 | 13.00 | 75 | 1,200 [566] | 34,600 [10.1] | 3.44 | 22,600 [6.6] | 2.40 | 8.50 |
| RHSL-HM3621 (RCSL-H*3621C*) | | 34,400 [10.1] | 25,350 [7.4] | 9,050 [2.7] | 11.10 | 13.00 | 75 | 1,200 [566] | 34,600 [10.1] | 3.44 | 22,600 [6.6] | 2.40 | 8.50 | |
| 42 | RHSL-HM4221 (RCSL-H*4821A*) ① | 41,000 [12.0] | 30,350 [8.9] | 10,650 [3.1] | 11.05 | 13.00 | 77 | 1,400 [661] | 41,500 [12.2] | 3.60 | 27,600 [8.1] | 2.54 | 8.50 | |
| | RCFL-H*4821A* | 41,000 [12.0] | 30,350 [8.9] | 10,650 [3.1] | 10.90 | 13.00 | 77 | 1,400 [661] | 41,500 [12.2] | 3.56 | 27,800 [8.1] | 2.54 | 8.50 | |
| | RCFL-H*4824A* | 41,000 [12.0] | 30,350 [8.9] | 10,650 [3.1] | 10.90 | 13.00 | 77 | 1,400 [661] | 41,500 [12.2] | 3.56 | 27,800 [8.1] | 2.54 | 8.50 | |
| | RBHP-24 (RCHL-48A1) | 40,000 [11.7] | 28,250 [8.3] | 11,750 [3.4] | 12.00 | 14.00 | 77 | 1,400 [661] | 41,500 [12.2] | 3.60 | 28,000 [8.2] | 2.66 | 9.00 | |
| | RHLL-HM4821 (RCSL-H*4821A*) | 42,000 [12.3] | 31,350 [9.2] | 10,650 [3.1] | 12.00 | 14.00 | 77 | 1,400 [661] | 41,000 [12.0] | 3.74 | 27,000 [7.9] | 2.66 | 9.00 | |
| 48 | RHSL-HM4821 (RCFL-H*4821A*) ① | 46,500 [13.6] | 33,950 [9.9] | 12,550 [3.7] | 10.90 | 13.00 | 77 | 1,600 [755] | 46,000 [13.5] | 3.54 | 30,600 [9.0] | 2.60 | 8.50 | |
| | RHSL-HM4821 (RCSL-H*4821A*) ① | 46,500 [13.6] | 33,950 [9.9] | 12,550 [3.7] | 10.90 | 13.00 | 77 | 1,600 [755] | 46,000 [13.5] | 3.54 | 30,600 [9.0] | 2.60 | 7.70 | |
| | RCFL-H*4821A* | 45,500 [13.3] | 32,950 [9.7] | 12,550 [3.7] | 10.85 | 13.00 | 77 | 1,475 [696] | 46,000 [13.5] | 3.58 | 30,400 [8.9] | 2.58 | 8.50 | |
| | RCFL-H*4824A* | 45,500 [13.3] | 32,950 [9.7] | 12,550 [3.7] | 10.85 | 13.00 | 77 | 1,475 [696] | 46,000 [13.5] | 3.58 | 30,400 [8.9] | 2.58 | 8.50 | |
| | RHLL-HM4821 (RCSL-H*4821A*) | 47,500 [13.9] | 34,950 [10.2] | 12,550 [3.7] | 12.00 | 14.00 | 77 | 1,600 [755] | 45,500 [13.3] | 3.72 | 29,800 [8.7] | 2.68 | 9.00 | |
| | RHLL-HM4824 (RCSL-H*4824A*) | 48,000 [14.1] | 36,500 [10.7] | 11,500 [3.4] | 12.00 | 14.00 | 77 | 1,625 [767] | 45,500 [13.3] | 3.74 | 29,800 [8.7] | 2.68 | 9.00 | |
| | RHSL-HM4824 (RCSL-H*4824A*) | 46,500 [13.6] | 33,950 [9.9] | 12,550 [3.7] | 10.90 | 13.00 | 77 | 1,600 [755] | 46,000 [13.5] | 3.54 | 30,600 [9.0] | 2.60 | 8.50 | |
| 60 | RHLL-HM6024 (RCSL-H*6024A*) ① | 58,500 [17.1] | 41,750 [12.2] | 16,750 [4.9] | 10.90 | 13.00 | 77 | 1,875 [885] | 56,000 [16.4] | 3.64 | 34,400 [10.1] | 2.50 | 8.50 | |

① Highest sales volume tested combination required by D.O.E. test procedures.

[] Designates Metric Conversions

Electrical and Physical Data

| Model Number 13PJL | ELECTRICAL | | | | | | | PHYSICAL | | | | | |
|-----------------------|---|--------------------------|----------------------------|-----------------------------------|----------------------------------|------------------------------|-----------------|-------------------------------------|----------|-------------|-----------------------------|---------------|--------------------|
| | Phase Frequency (Hz) Voltage (Volts) | Compressor | | Fan Motor Full Load Amperes (FLA) | Minimum Circuit Ampacity Amperes | Fuse or HACR Circuit Breaker | | Outdoor Coil | | | Refrig. Per Circuit Oz. [g] | Weight | |
| | | Rated Load Amperes (RLA) | Locked Rotor Amperes (LRA) | | | Minimum Amperes | Maximum Amperes | Face Area Sq. Ft. [m ²] | No. Rows | CFM [L/s] | | Net Lbs. [kg] | Shipping Lbs. [kg] |
| Rev. 3/31/09 | | | | | | | | | | | | | |
| 18 | 1-60-208/230 | 9/9 | 48 | 0.6 | 12/12 | 15/15 | 20/20 | 11.06 [1.03] | 1 | 1700 [802] | 91 [2580] | 144 [65.3] | 152 [68.9] |
| 24 | 1-60-208/230 | 12.8/12.8 | 58.3 | 0.6 | 17/17 | 20/20 | 25/25 | 11.06 [1.03] | 1 | 2370 [1118] | 91 [2580] | 130 [59.0] | 138 [62.6] |
| 30 | 1-60-208/230 | 14.1/14.1 | 73 | 0.8 | 19/19 | 25/25 | 30/30 | 13.72 [1.27] | 1 | 2800 [1321] | 101 [2863] | 198 [89.8] | 208 [94.3] |
| 36 | 1-60-208/230 | 17/17 | 96.7 | 1.2 | 23/23 | 30/30 | 35/35 | 16.39 [1.52] | 1 | 3575 [1687] | 109 [3090] | 215 [97.5] | 227 [103] |
| 42 | 1-60-208/230 | 21.8/21.8 | 112 | 1.2 | 29/29 | 35/35 | 50/50 | 21.85 [2.03] | 1 | 3575 [1687] | 150 [4252] | 202 [91.6] | 214 [97.1] |
| 48 | 1-60-208/230 | 21.8/21.8 | 117 | 1.2 | 29/29 | 35/35 | 50/50 | 21.85 [2.03] | 1 | 3575 [1687] | 141 [3997] | 205 [93.0] | 217 [98.4] |
| 60 | 1-60-208/230 | 26.3/26.3 | 134 | 1.2 | 35/35 | 45/45 | 60/60 | 21.85 [2.03] | 1 | 3575 [1687] | 228 [6464] | 209 [94.8] | 221 [100.2] |

- NOTES:
 ① 20 Fins per inch.
 ② Factory charged for 15 ft. line set.

[] Designates Metric Conversions

BEFORE PURCHASING THIS APPLIANCE, READ IMPORTANT ENERGY COST AND EFFICIENCY INFORMATION AVAILABLE FROM YOUR RETAILER.

GENERAL TERMS OF LIMITED WARRANTY

Ruud will furnish a replacement for any part of this product which fails in normal use and service within the applicable periods stated, in accordance with the terms of the limited warranty.

For Complete Details of the Limited Warranty, Including Applicable Terms and Conditions, See Your Local Installer or visit www.Ruud.com.

Condenser Coil leaks caused by
 factory defectsFive (5) Years
 Conditional Compressor*Ten (10) Years
 Any Other Part.....Five (5) Years

*See Product Warranty Card for Details.

Unit Dimensions

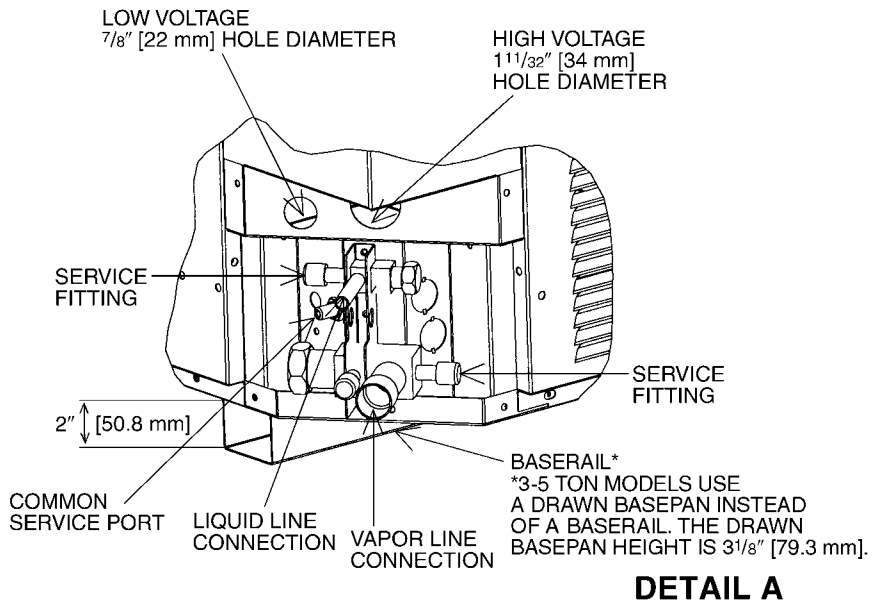
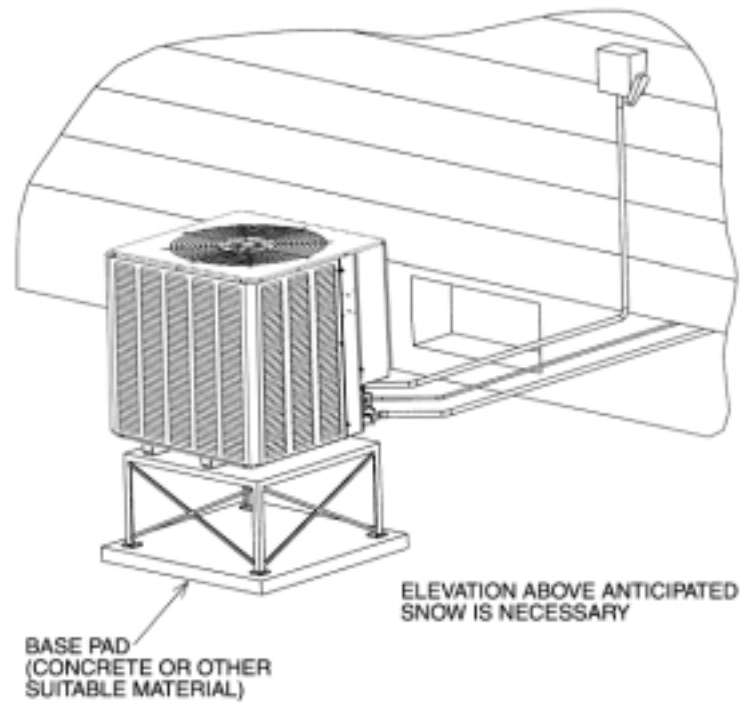
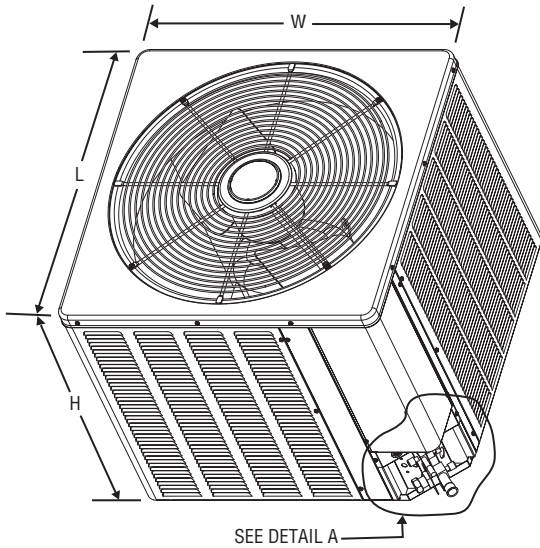

| Model Number | Height "H" (Inches) [mm] | Length "L" (Inches) [mm] | Width "W" (Inches) [mm] |
|--------------|---|---|---|
| 13PJL | | | |
| 18, 24 | 26 ¹ / ₄ [666.75] | 23 ⁵ / ₈ [600.07] | 23 ⁵ / ₈ [600.07] |
| 30 | 26 ¹ / ₄ [666.75] | 27 ⁵ / ₈ [701.67] | 27 ⁵ / ₈ [701.67] |
| 36 | 27 ³ / ₈ [695.32] | 31 ⁵ / ₈ [803.27] | 31 ⁵ / ₈ [803.27] |
| 42, 48, 60 | 35 ³ / ₈ [898.52] | 31 ⁵ / ₈ [803.27] | 31 ⁵ / ₈ [803.27] |

[] Designates Metric Conversions

Heat Pump Refrigerant Line Size Information

| System Capacity | Line Size Connection Size (Inch I.D.) [mm] | Line Size (Inch O.D.) [mm] | Liquid Line Sizing (R410A) | | | | | |
|--------------------------------------|--|----------------------------|---|------------|------------|-------------|-------------|-------------|
| | | | Outdoor Unit Above or Below Indoor Coil (Heat Pumps Only) | | | | | |
| | | | Total Equivalent Length—Feet [m] | | | | | |
| | | | 25 [7.62] | 50 [15.24] | 75 [22.86] | 100 [30.48] | 125 [38.10] | 150 [45.72] |
| Maximum Vertical Separation—Feet [m] | | | | | | | | |
| 1½ Ton | 3/8" [9.53] | 1/4 [6.35] | 25 [7.62] | 40 [12.19] | 25 [7.62] | 9 [2.74] | N/A | N/A |
| | | 5/16 [7.94] | 25 [7.62] | 50 [15.24] | 62 [18.90] | 58 [17.68] | 53 [16.15] | 49 [14.94] |
| | | 3/8* [9.53] | 25 [7.62] | 50 [15.24] | 75 [22.86] | 72 [21.95] | 70 [21.34] | 68 [20.73] |
| 2 Ton | 3/8" [9.53] | 1/4 [6.35] | 23 [7.01] | N/A | N/A | N/A | N/A | N/A |
| | | 5/16 [7.94] | 25 [7.62] | 36 [10.97] | 29 [8.84] | 23 [7.01] | 16 [4.88] | 9 [2.74] |
| | | 3/8* [9.53] | 25 [7.62] | 50 [15.24] | 72 [21.95] | 70 [21.34] | 68 [20.73] | 65 [19.81] |
| 2½ Ton | 3/8" [9.53] | 1/4 [6.35] | 25 [7.62] | N/A | N/A | N/A | N/A | N/A |
| | | 5/16 [7.94] | 25 [7.62] | 49 [14.94] | 38 [11.58] | 27 [8.23] | 17 [5.18] | 6 [1.83] |
| | | 3/8* [9.53] | 25 [7.62] | 50 [15.24] | 68 [20.73] | 65 [19.81] | 62 [18.90] | 58 [17.68] |
| 3 Ton | 3/8" [9.53] | 5/16 [7.94] | 25 [7.62] | 50 [15.24] | 37 [11.28] | 22 [6.71] | 7 [2.13] | N/A |
| | | 3/8* [9.53] | 25 [7.62] | 50 [15.24] | 68 [20.73] | 63 [19.20] | 58 [17.68] | 53 [16.15] |
| 3½ Ton | 3/8" [9.53] | 5/16 [7.94] | 25 [7.62] | 23 [7.01] | 4 [1.22] | N/A | N/A | N/A |
| | | 3/8* [9.53] | 25 [7.62] | 50 [15.24] | 43 [13.11] | 36 [10.97] | 30 [9.14] | 24 [7.32] |
| 4 Ton | 3/8" [9.53] | 3/8* [9.53] | 25 [7.62] | 46 [14.02] | 38 [11.58] | 30 [9.14] | 22 [6.71] | 15 [4.57] |
| | | 1/2 [12.7] | 25 [7.62] | 50 [15.24] | 56 [17.07] | 55 [16.76] | 53 [16.15] | 52 [15.85] |
| 5 Ton | 3/8" [9.53] | 3/8* [9.53] | 25 [7.62] | 50 [15.24] | 56 [17.07] | 44 [13.41] | 32 [9.75] | 20 [6.10] |
| | | 1/2 [12.7] | 25 [7.62] | 50 [15.24] | 75 [22.86] | 81 [24.69] | 79 [24.08] | 76 [23.16] |

NOTES:
 *Standard line size
 N/A = Application not recommended.

| Suction Line Length/Size versus Capacity Multiplier (R-410A) | | | | | | | | |
|--|---|--|---|---|-------------------|-------------------|-------------------|--|
| Unit Size | 1½ Ton | 2 Ton | 2½ Ton | 3 Ton | 3½ Ton | 4 Ton | 5 Ton | |
| Suction Line Connection Size | 3/4" [19.05] I.D. | | | 7/8" [22.23] I.D. | | | | |
| Suction Line Run—Feet [m] | 5/8" [15.88 mm] O.D. Opt. 3/4" [19.05 mm] O.D. Std.* | 5/8" [15.88 mm] O.D. Opt. 3/4" [19.05 mm] O.D. Std.* 7/8" [22.23 mm] O.D. Opt. | 3/4" [19.05 mm] O.D. Opt. 7/8" [22.23 mm] O.D. Std.* | 7/8" [22.23 mm] O.D. Opt. 1 1/8" [28.58 mm] O.D. Std.* | | | | |
| 25' [7.62] | Optional Standard Optional | 1.00 1.00 — | 1.00 1.00 1.00 | 1.00 1.00 — | 1.00 1.00 — | 1.00 1.00 — | 1.00 1.00 — | |
| 50' [15.24] | Optional Standard Optional | 0.98 0.99 — | 0.98 0.99 — | 0.96 0.98 0.99 | 0.98 0.99 — | 0.99 0.99 — | 0.99 0.99 — | |
| 100' [30.48] | Optional Standard Optional | 0.95 0.96 — | 0.95 0.96 — | 0.94 0.96 0.97 | 0.96 0.97 — | 0.96 0.98 — | 0.97 0.98 — | |
| 150' [45.72] | Optional Standard Optional | 0.92 0.93 — | 0.92 0.94 — | 0.91 0.93 0.95 | 0.94 0.95 — | 0.94 0.96 — | 0.94 0.97 — | |

NOTES:
 *Standard line size
 N/A = Using suction line larger than shown in chart will result in poor oil return and is not recommended. [] Designates Metric Conversions

NOTES

Before proceeding with installation, refer to installation instructions packaged with each model, as well as complying with all Federal, State, Provincial, and Local codes, regulations, and practices.

**Ruud Heating,
Cooling and
Water Heating**

P.O. Box 17010, Fort Smith, AR 72917



"In keeping with its policy of continuous progress and product improvement, Ruud reserves the right to make changes without notice."