

INSTALLATION & OPERATING INSTRUCTIONS

Gas-Fired Pool & Spa Heater

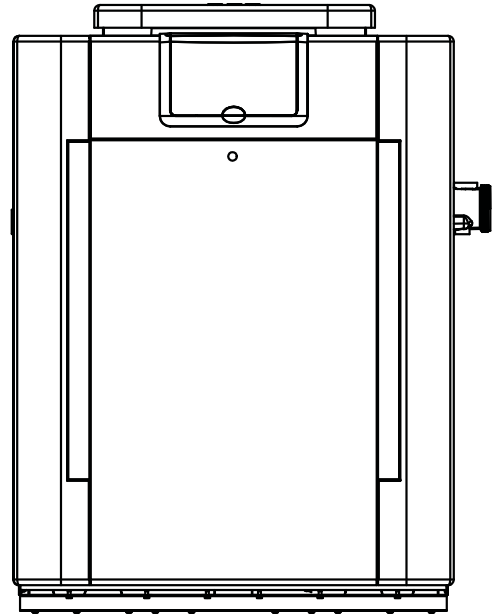

**Atmospheric Models
206A, 266A, 336A & 406A**

**Lo NOx Models
207A, 267A, 337A & 407A**

WARNING: If these instructions are not followed exactly, a fire or explosion may result causing property damage, personal injury or death.

Do not store or use gasoline or other flammable vapors and liquids in the vicinity of this or any other appliance.

WHAT TO DO IF YOU SMELL GAS:

- Do not try to light any appliance.
- Do not touch any electrical switch; do not use any phone in your building.
- Immediately call your gas supplier from a neighbor's phone. Follow the gas supplier's instructions.
- If you cannot reach your gas supplier, call the fire department.

Installation and service must be performed by a qualified installer, service agency or the gas supplier.

This manual should be maintained in legible condition and kept adjacent to the heater or in a safe place for future reference.

WATER CHEMISTRY
(Corrosive water voids all warranties)

For your health and the protection of your pool equipment, it is essential that your water be chemically balanced. The following levels must be used as a guide for balanced water.

Recommended Level(s)	Fiberglass Pools	Fiberglass Spas	Other Pool & Spa Types
Water Temp. (Deg. F)	68 to 88	89 to 104	68 to 104
pH	7.3 to 7.4	7.3 to 7.4	7.6 to 7.8
Total Alkalinity (PPM)	120 to 150	120 to 150	80 to 120
Calcium Hardness (PPM)	200 to 300	150 to 200	200 to 400
Salt (PPM)	4500 MAXIMUM	4500 MAXIMUM	4500 MAXIMUM
Free Chlorine (PPM)*	2 to 3	2 to 3	2 to 3
Total Dissolved Solids (PPM)	3000 MAXIMUM**	3000 MAXIMUM**	3000 MAXIMUM**

*** Free Chlorine MUST NOT EXCEED 5 PPM!**

** In salt water chlorinated pools, the total TDS can be as high as 6000 ppm.

- Occasional chemical shock dosing of the pool or spa water should not damage the heater providing the water is balanced.
- Automatic chemical dosing devices and salt chlorinators are usually more efficient in heated water, unless controlled, they can lead to excessive chlorine level **which can damage your heater, and which is not covered under warranty.**
- Further advice should be obtained from your pool or spa builder, accredited pool shop, or chemical supplier for the correct levels for your water.

Rev. 22 reflects the following:

Changes to: Water Chemistry information on page 2, Pressure switch photo and warning on page 7, Note on page 19, Step 7 on page 25, Wiring Diagram on page 30, Remote Control Wiring on page 41, note on page 42, Flow Chart on page 50

Additions: Note on page 26, Instructions for AFT board on pages 37-40

Deletions: None

CONTENTS

<p>4 PART ONE OWNER'S OPERATING INSTRUCTIONS</p> <p>4 SECTION 1 START-UP PROCEDURES</p> <p>4 Before Start-Up</p> <p>5 Lighting Instructions & Shut-Off Procedures - Manually Lighted Pilots MV</p> <p>6 Operating Instruction & Shut-Off Procedures - Automatically Lighted Pilots IID</p> <p>7 After Start-Up</p> <p>7 SECTION 2 CAUTION</p> <p>8 SECTION 3 MAINTENANCE & CARE PROCEDURES</p> <p>8 Pool & Spa Water Chemistry</p> <p>8 Automatic Chlorinators & Chemical Feeders</p> <p>9 Cold Weather Operation</p> <p>9 Winterizing the Pool & Spa Heater</p> <p>10 PART TWO INSTALLATION & SERVICE INSTRUCTIONS</p> <p>10 SECTION 1 RECEIVING EQUIPMENT</p> <p>11 SECTION 2 GENERAL SPECIFICATIONS</p> <p>11 SECTION 3 INSTALLATION INSTRUCTIONS</p> <p>11 Code Requirements</p> <p>12 Clearances</p> <p>12 Outdoor Heater Installation</p> <p>14 Florida Building Code 2001</p> <p>15 Indoor Heater Installation</p> <p>15 Outdoor Stack/Indoor Stack</p> <p>16 Atmospheric Specifications and Dimensions</p> <p>17 Lo NOx Specifications and Dimensions</p> <p>18 Combustion and Ventilation Air</p> <p>18 Vent Piping</p> <p>19 Gas Supply Connections</p> <p>20 Gas Pressure Regulator</p> <p>20 Gas Pressure Adjustment Locations</p> <p>20 Pipe Sizing For Gas Connections</p> <p>21 Flow Rates</p> <p>21 Heat Exchanger Pressure Drop Tables</p> <p>22 Polymer Headers</p> <p>22 Cast Iron Headers</p> <p>22 Unitherm Governor Operation</p> <p>23 Internal Automatic Bypass Valve</p> <p>23 External Auxiliary Bypass Valve</p> <p>23 Auxiliary Bypass Valve Adjustment</p> <p>23 Pressure Relief Valve Installation</p> <p>24 Plumbing— Water Connections</p> <p>25 Heat Exchanger Reversal Procedure</p> <p>26 Electrical Wiring</p> <p>26 Millivolt Models</p> <p>26 Digital Models</p> <p>27 Transformer Wiring</p> <p>28 Wiring Diagram - Millivolt (Mechanical Therm.)</p> <p>29 Wiring Diagram - Digital Models, Atmospheric</p>	<p>30 Wiring Diagram - Digital Models, Lo NOx</p> <p>31 SECTION 4 SERVICING INSTRUCTIONS</p> <p>31 General Location of Controls</p> <p>32 Control Panel Removal</p> <p>32 Control Adjustments - Digital and AFT Models</p> <p>32 Control Adjustments - Millivolt Models</p> <p>33 Thermostat Operation - Digital Board</p> <p>35 Diagnostics</p> <p>35 Codes</p> <p>35 Reading a Fault</p> <p>36 Remote Control Installation and Operation</p> <p>36 Remote Operation</p> <p>36 Activating the Remote</p> <p>37 Thermostat Operation - AFT Board</p> <p>39 Status and Diagnostics</p> <p>40 Remote Control Installation and Operation</p> <p>40 Remote Operation</p> <p>40 Activating the Remote</p> <p>41 Remote Control Wiring</p> <p>41 2-Wire Remote Control</p> <p>41 3-Wire Remote Control</p> <p>42 Time Clock / Fireman's Switch</p> <p>42 Water Pressure Switch</p> <p>42 Flame Roll-Out Safety Switch</p> <p>42 High Limits</p> <p>43 Pilot Safety</p> <p>43 Burner Tray Removal (ATM)</p> <p>43 Gas Valve Removal (ATM)</p> <p>43 Main Burner and Orifice Removal (ATM)</p> <p>43 Pilot Removal and Cleaning</p> <p>44 Heat Exchanger Removal</p> <p>44 Tube Cleaning Procedure</p> <p>44 Desooting Procedure</p> <p>44 Combustion Chamber Removal</p> <p>44 Immersion Well Replacement</p> <p>45 Unitherm Governor (U.G.) Replacement</p> <p>45 Lo NOx Pool Heaters</p> <p>45 Operation</p> <p>45 Start-Up Procedures</p> <p>45 Visual Inspection</p> <p>45 Electrical</p> <p>45 Flame Roll-Out Safety Switch</p> <p>46 Burner Tray Removal</p> <p>46 Gas Valve Removal</p> <p>46 Main Burner and Orifice Removal</p> <p>46 Pilot Removal</p> <p>46 Combustion Blower Removal</p> <p>47 SECTION 5 TROUBLESHOOTING</p> <p>48 Electrical - Standing Pilot Millivolt</p> <p>49 Electrical - Electronic Ignition (IID)</p> <p>50 Digital/AFT Control Logic - Flow Chart</p> <p>51 SECTION 6 REPLACEMENT PARTS</p> <p>52 Illustrated Parts List</p> <p>55 Part Numbers</p>
---	--

PART ONE

OWNER'S OPERATING INSTRUCTIONS

FOR YOUR SAFETY - READ BEFORE OPERATING

WARNING: IF YOU DO NOT FOLLOW THESE INSTRUCTIONS EXACTLY, A FIRE OR EXPLOSION MAY RESULT, CAUSING PROPERTY DAMAGE, PERSONAL INJURY OR LOSS OF LIFE.

SECTION 1 - START-UP PROCEDURES

Your pool/spa heater has been designed for years of safe and reliable pool/spa water heating. It is available with millivolt or electronic ignition. ASME-certified units, typically used in commercial applications, are also available. This manual provides installation, operation, maintenance, and service information for these heaters.

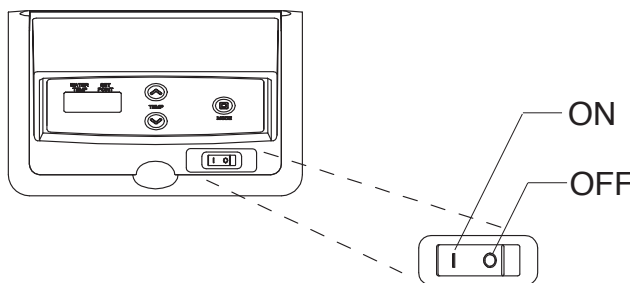

If your heater has been installed correctly, operating the heater is an easy task. The upper front panel of the heater contains the control center that allows you to turn the heater On or Off and adjust the temperature settings for the pool or spa. The temperature range is factory set from 65°F (18°C) to 104°F (40°C). See figure above for location of toggle switch to turn the heater On and Off. Section 4 of this manual contains more details about the use of the controls in the Control Adjustments subsection (page 32).

BEFORE START-UP

BURNERS

Clean main burners, combustion fan (if equipped) and air louvers of dust, lint and debris. Keep heater area clear and free from combustibles, flammable liquids and chemicals. Do not obstruct the flow of combustion and ventilation air.

WATER

Water must be flowing through the heater during operation. Ensure that the system is filled with water and that the pump is operating.

CAUTION: Propane gas is heavier than air and will settle on the ground. Since propane can accumulate in confined areas, extra care should be exercised when lighting propane heaters.

LIGHTING INSTRUCTIONS AND SHUT-OFF PROCEDURES

MILLIVOLT SYSTEM (MANUALLY LIGHTED PILOT)

- A. This appliance has a pilot that must be lit by hand. When lighting the pilot, follow these instructions exactly.
- B. BEFORE LIGHTING, smell all around the appliance area for gas. Be sure to smell near the floor because some gas is heavier than air and will settle on the floor.

WHAT TO DO IF YOU SMELL GAS:

- *Do not try to light any appliance.
- *Do not touch any electric switch; do not use any phone in your building.
- *Immediately call your gas supplier from a neighbor's phone. Follow the gas supplier's instructions.

*If you cannot reach your gas supplier, call the fire department.

- C. Use only your hand to push in or turn the gas control knob. Never use tools. If the knob will not push in or turn by hand, do not try to repair it. Call a qualified service technician. Force or attempted repair may result in a fire or explosion.
- D. Do not use this appliance if any part has been under water. Immediately call a qualified service technician to inspect the appliance and to replace any part of the control system and any gas control which has been under water.

LIGHTING INSTRUCTIONS

1. **STOP!** Read the safety information above.
2. Set the thermostat on the lowest setting.
3. Turn On/Off switch to the "Off" position.
4. Remove heater door panel.
5. Push in gas control knob slightly and turn clockwise  to "Off".

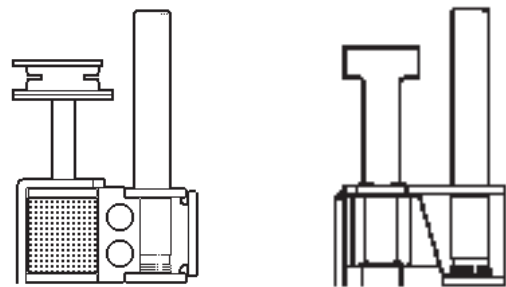
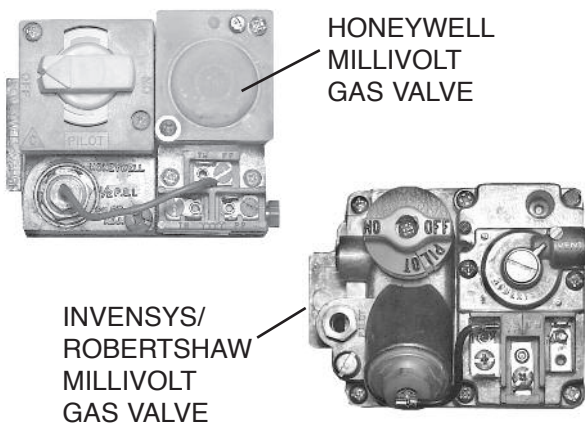

NOTE: Knob cannot be turned from "Pilot" to "Off" unless knob is pushed in slightly. Do not force.

6. Wait 5 minutes to clear out any gas. If you then smell gas, **STOP!** Follow "B" in the safety information above. If you don't smell gas, go to the next step.
7. Locate pilot mounted on the right side panel of the burner tray.



HONEYWELL PILOT

ROBERTSHAW PILOT

8. Turn gas control knob counter-clockwise  to "Pilot"
9. Place flame to end of pilot tube. Push in control knob all the way and hold to light pilot. Continue to hold control knob in for about one minute after the pilot is lighted, release knob and it will pop back up. Pilot should remain lighted. If it goes out, repeat steps 5 through 9. If knob does not pop up when released, stop and immediately call your service technician or gas supplier.
10. Stand to the side of the heater and turn the gas control knob counter-clockwise  to "On".
11. Replace heater door panel.
12. Turn On/Off switch to the "On" position.
13. Set thermostat to the desired setting.

SHUT-OFF PROCEDURE

1. Set the thermostat to the lowest setting.
2. Turn On/Off switch to the "Off" position.
3. Remove heater door panel.
4. Push the gas control knob slightly and turn clockwise  to "Off". Do not force.
5. Replace heater door panel.

CAUTION: Propane gas is heavier than air and will settle on the ground. Since propane can accumulate in confined areas, extra care should be exercised when lighting propane heaters.

OPERATING INSTRUCTIONS AND SHUT-OFF PROCEDURES

ELECTRONIC IGNITION SYSTEM

(AUTOMATICALLY LIGHTED PILOT)

- A. This appliance is equipped with an ignition device which automatically lights the pilot. Do not try to light the pilot by hand.
- B. BEFORE OPERATING, smell all around the appliance area for gas. Be sure to smell near the floor because some gas is heavier than air and will settle on the floor.





WHAT TO DO IF YOU SMELL GAS:

- *Do not try to light any appliance.
- *Do not touch any electric switch; do not use any phone in your building.
- *Immediately call your gas supplier from a neighbor's phone. Follow the gas supplier's instructions.

*If you cannot reach your gas supplier, call the fire department.

- C. Use only your hand to push in or turn the gas control knob. Never use tools. If the knob will not push in or turn by hand, do not try to repair it. Call a qualified service technician. Force or attempted repair may result in a fire or explosion.
- D. Do not use this appliance if any part has been under water. Immediately call a qualified service technician to inspect the appliance and to replace any part of the control system and any gas control which has been under water.

OPERATING INSTRUCTIONS

1. **STOP!** Read the safety information above.
2. Set the thermostat to the lowest setting.
3. Turn off all electrical power to the appliance.
4. This appliance is equipped with an ignition device which automatically lights the pilot. Do not try to light the pilot by hand.
5. Remove heater door panel.
6. **For Honeywell valve:** Turn gas control knob clockwise  to "Off".
For Robertshaw valve: Models 266-406: Turn gas control knob clockwise  to "Off". Model 206: Push in and move gas control lever counter-clockwise  to "Off" position.
7. Wait 5 minutes to clear out any gas. If you then smell gas, **STOP!** Follow "B" in the safety information above. If you don't smell gas, go to the next step.
8. Turn gas control knob counter-clockwise  to "On". (Honeywell VR 8300 and Robertshaw 7000)
9. Replace heater door panel.
10. Turn on all electrical power to the appliance.
11. Set thermostat to desired setting.
12. If the appliance will not operate, follow the instructions "To Turn Off Gas To Appliance" and call your service technician or gas supplier.

HONEYWELL VR 8300 GAS VALVE IID

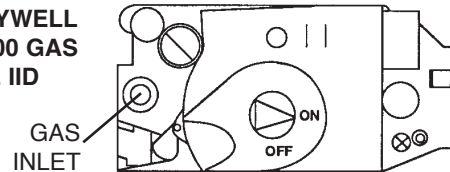

ROBERTSHAW 7000 GAS VALVE IID

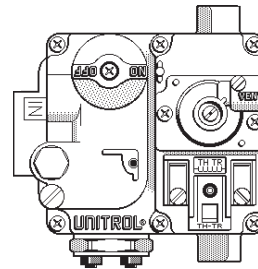

ROBERTSHAW 7200 GAS CONTROL LEVER SHOWN IN "OFF" POSITION

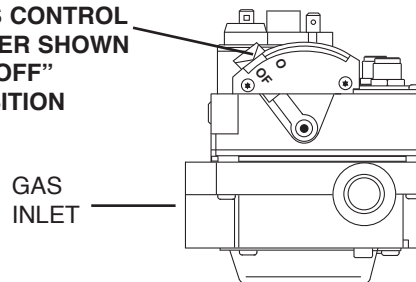

SHUT-OFF PROCEDURES

1. Set the thermostat at the lowest setting.
2. Turn off all the electrical power to the appliance if service is to be performed.
3. Remove heater door panel.
4. **For Honeywell VR 8300 and Robertshaw 7000 gas valve.** Turn gas control knob clockwise 

- to "Off". Make sure knob rest against stop.
For Robertshaw 7200 gas valve. Push in and move gas control lever counter-clockwise  to "Off" position.
5. Replace heater door panel.

AFTER START-UP

Feel the inlet and outlet pipes. Outlet pipe should be only slightly warmer than the inlet. It should not be hot.

WARNING: *Should overheating occur or the gas supply fail to shut off, turn off the manual gas control to the appliance.*

VISUAL INSPECTION - ATMOSPHERIC HEATERS

With the heater on, remove the door and make a visual check of the pilot and burner. The flame should be blue with a well-defined pattern.

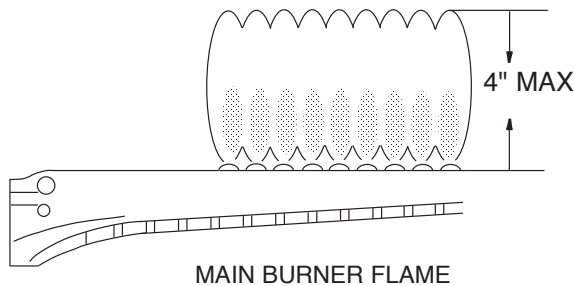

MAIN BURNER FLAME

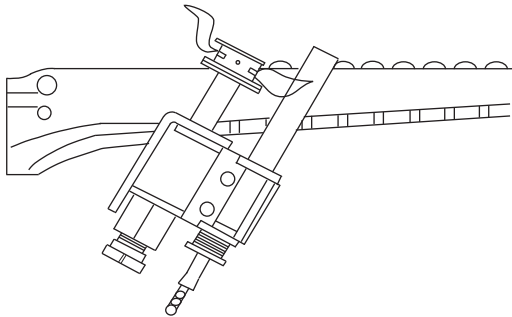

MILLIVOLT PILOT BURNER FLAME

A yellow or "floating" flame indicates restricted air openings or incorrect orifice size. Should this occur, shut the heater off and contact your installer or gas supplier.

WATER PRESSURE SWITCH

A water pressure switch is provided in the heater to shut off the burners in the event that water supply is interrupted. It is very important to verify that the switch electrically opens and shuts off the gas valve when water flow to the heater is interrupted. Otherwise, rapid and severe damage will likely occur to the heater. (The water pressure switch should be checked and adjusted for proper operation by a qualified service person at the time of installation and periodically checked thereafter. Refer to Pressure Switch Adjustment on pg. 42 of this manual).



WARNING: *Operation of the heater without water circulation will cause rapid and severe damage to the heater, and will void the warranty.*

SECTION 2 - CAUTION

Elevated water temperature can be hazardous. The U.S. Consumer Product Safety Commission has these guidelines:

1. Spa water temperatures should never exceed 104°F (40°C). A temperature of 100°F (38°C) is considered safe for a healthy adult. Special caution is suggested for young children.
2. Drinking of alcoholic beverages before or during spa or hot tub use can cause drowsiness which could lead to unconsciousness and subsequently result in drowning.
3. *Pregnant Women Beware!* Soaking in water over 102°F (39°C) can cause fetal damage during the first three months of pregnancy resulting in the birth of a brain-damaged or deformed child. Pregnant women should stick to the 100°F (38°C) maximum rule.
4. Before entering the spa or hot tub, users should check the water temperature with an accurate thermometer; spa or hot tub thermostats may err in regulating water temperatures by as much as 4°F (2.2°C).
5. Persons with a medical history of heart disease, circulatory problems, diabetes, or blood pressure problems should obtain a physician's advice before using pools or hot tubs.
6. Persons taking medications which induce drowsiness, such as tranquilizers, antihistamines, or anti-coagulants, should not use spas or hot tubs.

SECTION 3 - MAINTENANCE AND CARE PROCEDURES

WARNING: *Check the heater for possible rodent nests after long periods of non-use.*

To be followed one month after start-up and then semi-annually.

1. Inspect top of heater and draft hood for soot, a sticky black substance around finned tubes and "V" baffles, and open flue gas passageways. Any visible soot should be cleaned for proper operation.

CAUTION: *Soot may be combustible. Wet sooted surfaces completely prior to cleaning. Do not use steel wire brush.*

2. Clean main burners and pilot burner of dust and lint.
3. Inspect and operate all controls, gas valve and pressure relief valve (if equipped).
4. Make visual check of the burner and pilot flames. Flame pattern on the main burner and pilot is illustrated on page 7. Yellow flame means restriction of the air openings. Lifting or blowing flame indicates high gas pressure. Low flame means low gas pressure. Should the latter occur, shut the heater off and contact your gas supplier or qualified service agency.
5. On indoor heaters, clean room intake openings to ensure adequate flow of combustion and ventilation air.

CAUTION: *Combustion air must not be contaminated by corrosive chemical fumes which can damage the heater and void the warranty.*

6. Keep area around heater clear and free from combustible materials, gasoline and other flammable and corrosive vapors and liquids.

IF HEATER WILL NOT FIRE:

If you have no electrical power, it may be that your "circuit breaker" has tripped. Try re-setting it.

If you have electrical power but the heater will not fire check the following or see Troubleshooting section:

1. The time clock must be in the "ON" position.

2. Your pump strainer basket may be full. If so remove debris.
3. Your filter may be dirty. If so, backwash or clean filter. (To tell if your filter is dirty, look to see if the filter pressure will be higher than usual).
4. The pump may have lost its prime and be running dry. Check the pressure on the filter. If there is no pressure; then you are not moving water (or your gauge is broken). Try to get the pump to run at its normal flow rate.

POOL & SPA WATER CHEMISTRY

Chemical imbalance can cause severe damage to your heater and associated equipment. Maintain your water chemistry according to the chart on page 2. If the mineral content and dissolved solids in the water become too high, scale forms inside the heat exchanger tubes, reducing heater efficiency and damaging the heater. If the pH drops below 7.2, this will cause corrosion of the heat exchanger and severely damage the heater. **Heat exchanger damage resulting from chemical imbalance is not covered by the warranty.**

AUTOMATIC CHLORINATORS AND CHEMICAL FEEDERS

All chemicals must be introduced and completely diluted into the pool or spa water before being circulated through the heater. Do not place sanitizing chemicals in the skimmer. High chemical concentrations will result when the pump is not running (e.g. overnight).

Chlorinators must feed downstream of the heater and have an anti-siphoning device to prevent chemical back-up into the heater when the pump is shut off.

See plumbing diagrams on page 24.

NOTE: *High chemical concentrates from feeders and chlorinators that are out of adjustment will cause rapid corrosion to the heat exchanger. **Such damage is not covered under the warranty.***

The Lo NOx burners and orifice areas should be inspected annually. Dirt and debris can affect the operation of the heater and could damage the burners or prevent the heater from firing. **DO NOT** clean the burners with a wire brush.

COLD WEATHER OPERATION

IMPORTANT FREEZE INFORMATION

MODERATE CLIMATE: Heater operation can continue during short-term cold spells. When temperatures are between 0° and 32°F, flow (continuous pump operation) must be maintained.

CAUTION: Do not use the heater to maintain water temperatures just above freezing or for freeze protection. When heater is used during freezing weather, care must be taken to avoid freeze-ups. Continuous pump operation is a must. Additional protection may be required. The heater is not warranted against freeze-ups.

COLD CLIMATE: Prolonged operation with water temperatures below 50°F is not recommended. When starting the heater with water temperatures below 50°F, operate the heater continuously until higher temperatures are reached. Operating the heater for prolonged periods with pool water below 50°F can seriously damage the heater, and is not covered by the warranty.

For cold climate areas, please follow the winterizing procedures listed.

WINTERIZING THE POOL & SPA HEATER

Heaters installed outdoors in freezing climate areas may be shut down for the winter. Observe the following procedure for winterizing the heater:

1. Turn off gas valve, manual gas valve, and electrical supply to the heater.
2. Open drain plug located on the inlet/outlet header, (under water pipes). Remove the heat exchanger inspection panel on the side opposite water piping to gain access to the drain plug on the return header. Open drain plug on return header.

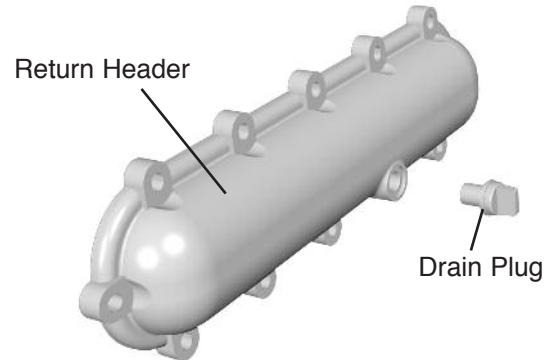

3. For ASME Heaters only: Disconnect compression fittings from the pressure switch and return header that connects to the 1/4" copper tube and allow the tube to drain.

PART TWO INSTALLATION AND SERVICE INSTRUCTIONS

SECTION 1 - RECEIVING EQUIPMENT

The manufacturer recommends that this manual be reviewed thoroughly before installing your pool/spa heater. If there are any questions that this manual does not answer, please contact the factory or your local representative.

On receipt of your equipment it is suggested that you visually check for external damage to the carton. If the carton is damaged, a note should be made on the Bill of Lading when signing for the equipment. Remove the heater from the carton. If it is damaged, report the damage to the carrier immediately. Save the carton.

These items are shipped inside a box in the carton with the heater:

STANDARD UNIT (POLYMER HEADERS)

1. "Pagoda" top
2. 2" CPVC union with "O" rings (2)
3. Plastic pipe finish flange for gas line
4. Bonding lug with mounting screw (Digital/AFT models only)

ASME UNIT (CAST IRON HEADERS)

1. "Pagoda" top
2. In/Out flanges (2)
3. 1-1/2" flange gaskets (2)
4. 2" flange gaskets (2)
5. Flange bolts (4)
6. Pressure relief valve
7. 2" CPVC adapters (2)
8. Plastic pipe finish flange for gas line.
9. Bonding lug with mounting screw. (Digital/AFT models only)

Be sure that you receive the number of packages indicated on the Bill of Lading.

When ordering parts, you must specify the model and serial numbers of the heater. See below for location of serial number. When ordering under warranty conditions, you must also specify date of installation.

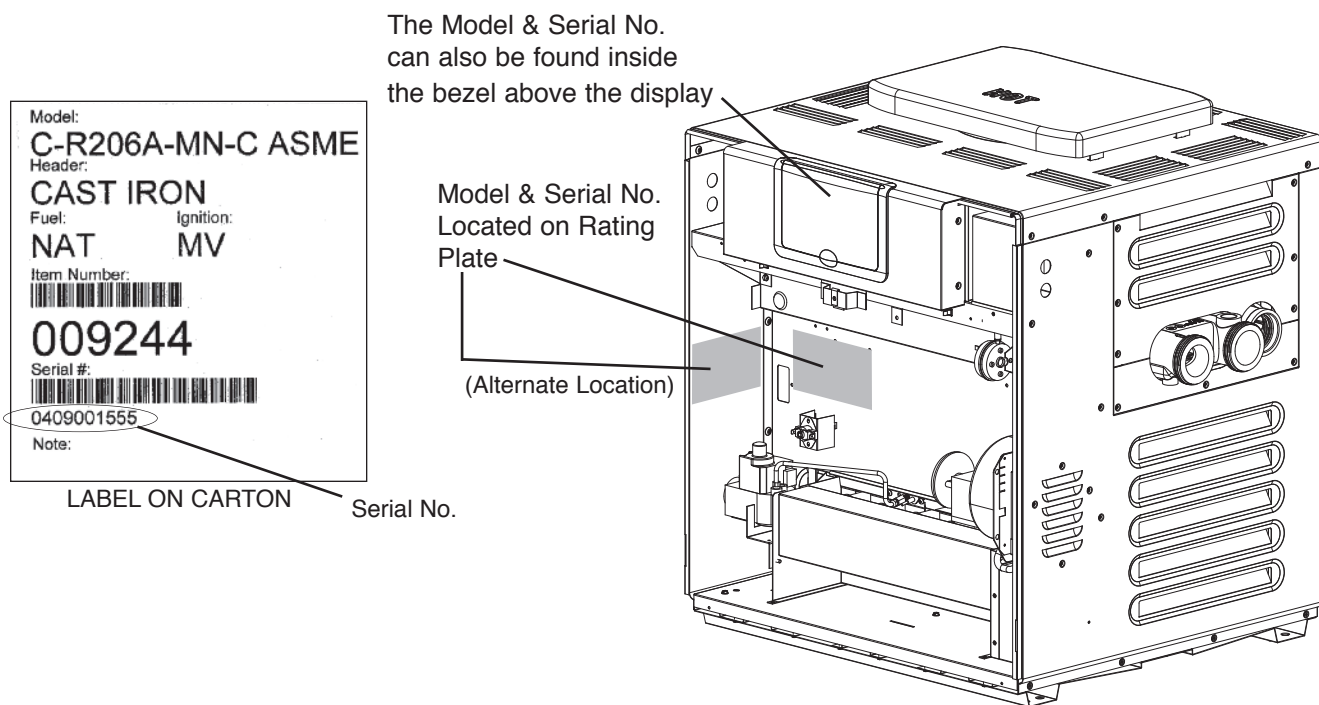

SECTION 2 - GENERAL SPECIFICATIONS

These heaters are design-certified and tested under the latest requirements of the ANSI Z21.56 / CSA 4.7 Standard for Gas-Fired Pool Heaters. All heaters can be used either indoor or outdoors. The appropriate top designated for each type of use is required. If necessary, the top can be changed at a later date to change from outdoor to indoor or vice versa. Millivolt heaters contain a self-generating electrical system operating between .25 and .75 VAC.

Ambient Temperature Rating of Heater Components

Millivolt Heater with Honeywell Gas Valve	+32°F to +175°F
Millivolt Heater with Robertshaw Gas Valve	0°F to +175°F
Electronic Ignition Heater*	-32°F to + 175°F

*Requires 120 or 240VAC Power Supply

Atmospheric heaters:

Rated inputs are suitable for up to 2,000 feet elevation. For elevations above 2000 feet, reduce input 4% for each 1,000 feet above sea level, as high elevation reduces combustion performance.

Lo NOx heaters:

Rated inputs are suitable for up to 5,000 feet elevation. For elevations above 5000 feet, consult the factory.

SECTION 3 - INSTALLATION INSTRUCTIONS

CALIFORNIA PROPOSITION 65 WARNING: This product contains chemicals known to the State of California to cause cancer, birth defects or other reproductive harm.

WARNING: This unit contains refractory ceramic fiber (RCF) insulation in the combustion chamber. RCF, as manufactured, does not contain respirable crystalline silica. However, following sustained exposure to very high temperatures (>2192F), the RCF can transform into crystalline silica (cristabolite). The International Agency for Research on Cancer (IARC) has classified the inhalation of crystalline silica (cristabolite) as carcinogenic to humans.

When removing the burners or heat exchangers, take precautions to avoid creating airborne dust and avoid inhaling airborne fibers. When cleaning spills, use wet sweeping or High Efficiency Particulate Air (HEPA) filtered vacuum to minimize airborne dust. Use feasible engineering controls such as local exhaust ventilation or dust collecting systems to minimize airborne dust. Wear appropriate personal protective equipment including gloves, safety glasses with side shields, and appropriate NIOSH certified respiratory protection, to avoid inhalation of airborne dust and airborne fiber particles.

IMPORTANT NOTICE

These instructions are intended only for the use of qualified personnel, specifically trained and experienced in the installation of this type of heating equipment and related system components. Installation and service personnel may be required by some states to be licensed. If your state is such, be sure your contractor bears the appropriate license. Persons not qualified shall not attempt to fix this equipment nor attempt repairs according to these instructions.

WARNING: *Improper installation, adjustment, alteration, service or maintenance may damage the equipment, create a hazard resulting in asphyxiation, explosion or fire, and will void the warranty.*

CODE REQUIREMENTS

NOTE: *The heater should not be located in an area where possible water leakage will result in damage to the area adjacent to the heater or to the structure. When such locations cannot be avoided, it is recommended that a suitable drain pan, with adequate drainage, be installed under the heater. The pan must not restrict combustion air flow.*

Installation must be in accordance with local codes, or, in the absence of local codes, with the latest edition of the National Fuel Gas Code, ANSI Z223.1/NFPA54 and National Electrical Code, ANSI/NFPA 70, and for Canada, the latest edition of CAN/CSA-B149 Installation Codes, and Canadian Electrical Code, CSA C22.1 Part 1 and Part 2.

CLEARANCES

ALL HEATERS

For clearances from combustible surfaces, see the chart below.

CLEARANCE FROM COMBUSTIBLE CONSTRUCTION	
INDOOR INSTALLATIONS:	
Top* - 30" (Drafthood)	Back - 6"
Front - Alcove (Open)	Right Side - 12" (Water Side)
Vent - 6"	Left Side - 6"
Floor** - 0"	(Opposite Water Side)
OUTDOOR INSTALLATION:	
Top* - Unobstructed (<i>Outdoor Stack</i>)	
Top*** - 36" (<i>Stackless Top</i>)	
Floor - 0"	Right Side - 12" (Water Side)
Back - 6"	Left Side - 6"
	(Opposite Water Side)

*Clearance from top of vent terminal.

**Do not install on carpeting.

***Clearance from top of heater.

When installed according to the listed minimum clearances from combustible construction, the pool heater can still be serviced without removing permanent construction around the heater.

However for ease of servicing, we recommend a clearance of at least 24" in the front, and at least 18" on the water connection side. This will enable the heater to be serviced in its installed location, that is, without movement or removal of the heater.

Clearances less than these (6" minimum), may require removal of the heater to service either the heat exchanger or the burner tray. In either case, the heater must be installed in a manner that will enable the heater to be serviced without removing any structure around the heater.

FLOORING: This heater can be installed on combustible flooring.

OUTDOOR HEATER INSTALLATION

These heaters are design-certified for outdoor installation, when equipped with the approved tops designated for outdoor use.

WARNING: The heater shall not be located in an area where water sprinklers, or other devices, may cause water to spray through the cabinet louvers and into the heater. This could cause internal rusting or damage electrical components, and void the warranty.

WARNING: Do not install within 3 feet of a heat pump or an outdoor condensing unit. Strong air intake from this type of equipment can disturb the combustion process and cause damage or personal injury.

HEATER WITH OUTDOOR STACKLESS TOP

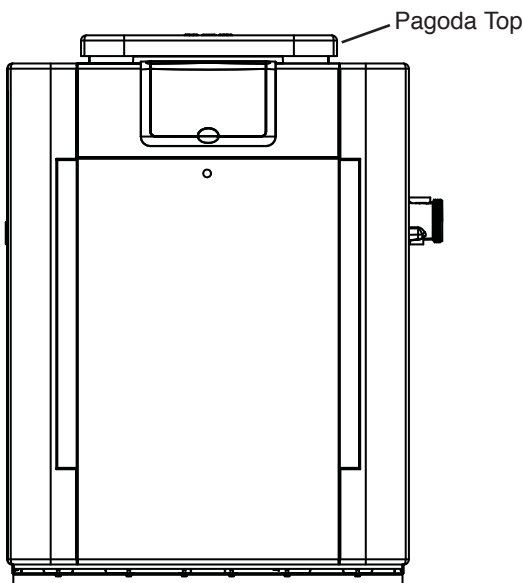

Pagoda Top Installation

1. Insert tabs into keyhole (4 places).

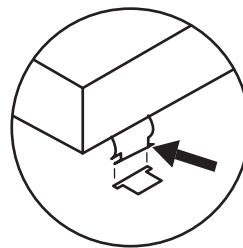

Pagoda Top
(Shipped inside
box in heater
carton)

2. Snap tabs into keyholes so as not to pull out.

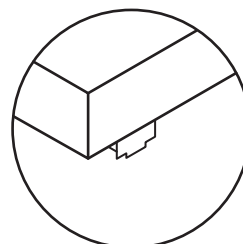

Heaters must not be installed under an overhang of less than three 3 ft from the top of the heater. Three sides must be open in the area under the overhang. Roof water drainage must be diverted away from the heaters installed under overhangs with the use of gutters.

For U.S. installations, the point from where the flue products exit the heater must be a minimum of 4 ft below, 4 ft horizontally from, or 1 ft above any door, window or gravity inlet into any building. The top surface of the heater shall be at least 3 ft above any forced air inlet, or intake ducts located within 10 ft horizontally.

For installations in Canada, pool heaters shall not be installed with the top of the vent assembly within 10 ft below, or to either side, of any opening into the building. Refer to the latest revisions of CAN/CSA-B149.

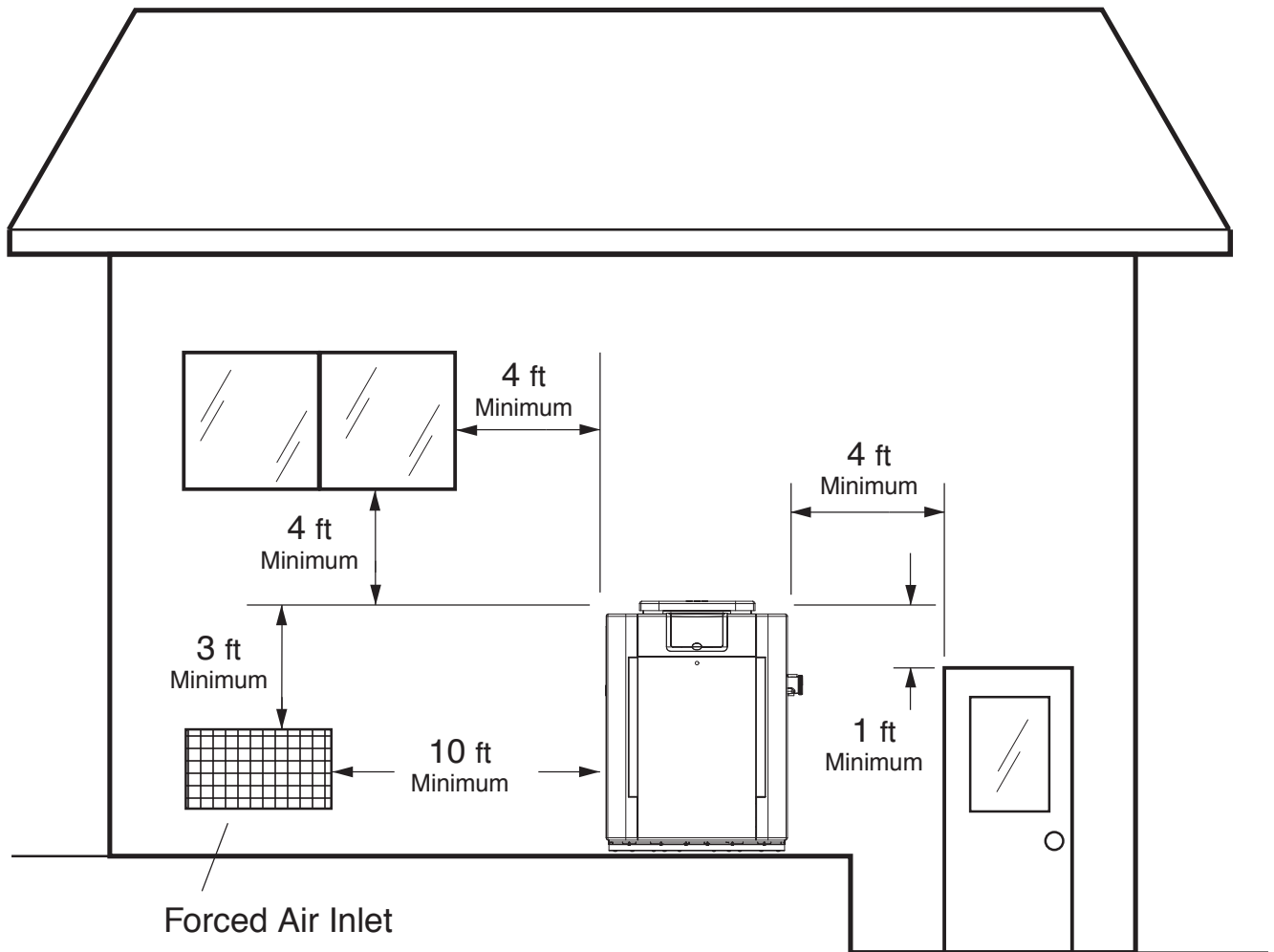

For installations in Florida, that must comply with the Florida Building Code 2001, follow the directions on p14 for the installation of hurricane tie-down brackets for all models.

FLORIDA BUILDING CODE 2001
WIND SPEED = 150 MPH, 3 SECOND GUST
EXPOSURE = C

206/266/336/406 Atmospheric

MODEL #	B
206	20"
266	23"
336	26"
406	29"

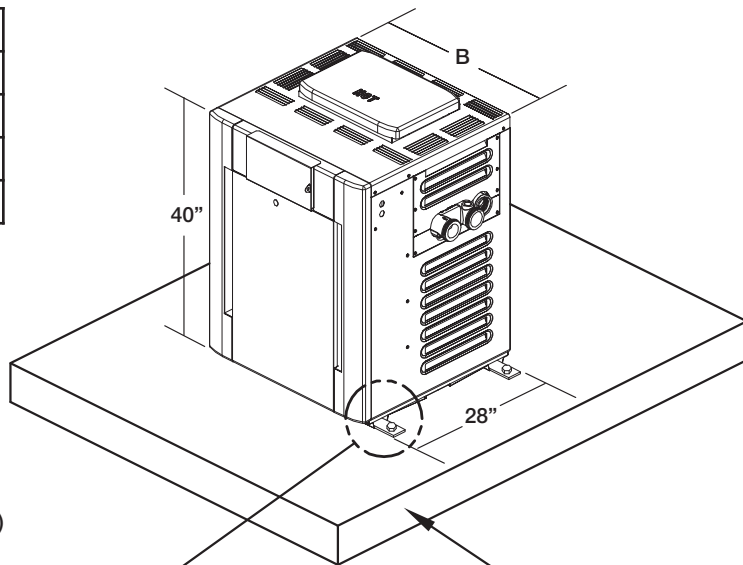

2" x 6" x 1/8" Pallet
 Anchor Bracket (4 Total) (Kit# 011636)

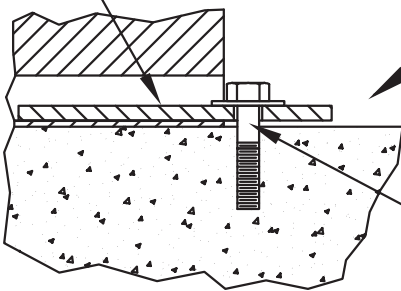

1/4" x 1-3/4" S.S. Tapcon Bolt & Washer (Field Supplied)
 NOTE: Use hole closest to unit with
 washer overlapping edge of unit.

3" Min. Conc.
 Pad by others

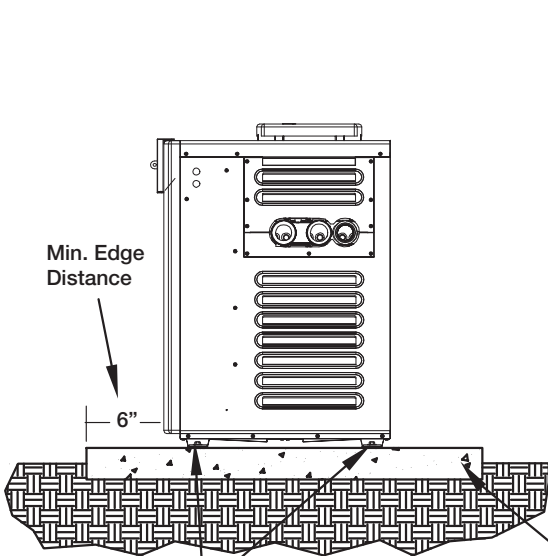

(1)-1/4" x 1-3/4" S.S. Tapcon Bolt & Washer (Field Supplied)
 Ea. Pallet Anchor Bracket
 Use hole closest to unit (4 total)

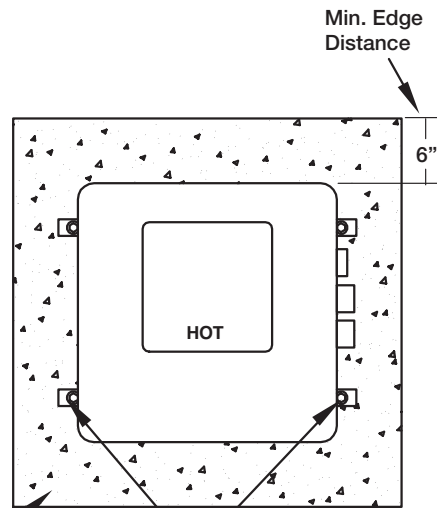

(1)-1/4" x 1-3/4" S.S. Tapcon Bolt & Washer (Field Supplied)
 Ea. Pallet Anchor Bracket
 Use hole closest to unit (4 total)

3" Min. Conc.
 Pad by others

INDOOR HEATER INSTALLATION

The heater is also design-certified for indoor installation when equipped with the approved draft hood.

For Canada, indoor installation is restricted to an enclosure that is not occupied and does not directly communicate with an occupied area. Refer to the latest edition of CAN/CSA-B149 for specific requirements. Locate heater as close as is practical to a chimney or gas vent. Heater must always be vented to the outside. See Vent Piping section (pg. 17-18) for details. Minimum allowable space is shown on the nameplate.

WARNING: Indoor heaters require a draft hood that must be connected to a vent pipe and properly vented to the outside. Failure to follow this procedure can cause fire or fatal carbon monoxide poisoning.

OUTDOOR STACK / INDOOR STACK

NOTE: The outdoor and indoor stacks are optional equipment and do not come standard with the heater.

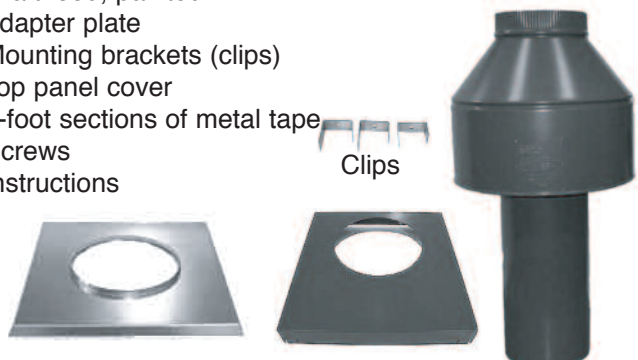
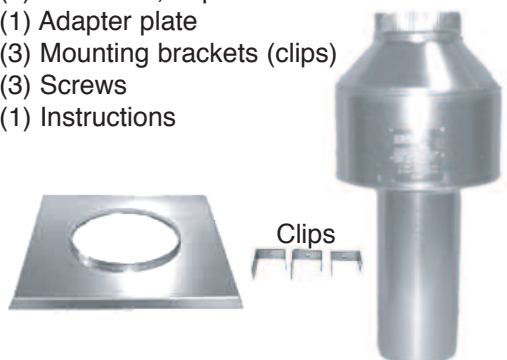
<p><u>OUTDOOR STACK KIT INCLUDES:</u></p> <ul style="list-style-type: none"> (1) Drafthood, painted (1) Adapter plate (3) Mounting brackets (clips) (1) Top panel cover (2) 1-foot sections of metal tape (3) Screws (1) Instructions 	<p><u>INDOOR STACK KIT INCLUDES:</u></p> <ul style="list-style-type: none"> (1) Drafthood, unpainted (1) Adapter plate (3) Mounting brackets (clips) (3) Screws (1) Instructions 
--	--

	OUTDOOR STACK	INDOOR STACK
Model	Part No.	Part No.
206A/207A	009834	009838
266A/267A	009835	009839
336A/337A	009836	009840
406A/407A	009837	009841

****REFER TO INSTALLATION INSTRUCTIONS INSIDE BOX FOR INSTRUCTIONS ON HOW TO INSTALL OUTDOOR/INDOOR STACK.**

SPECIFICATIONS AND DIMENSIONS

ATMOSPHERIC UNITS

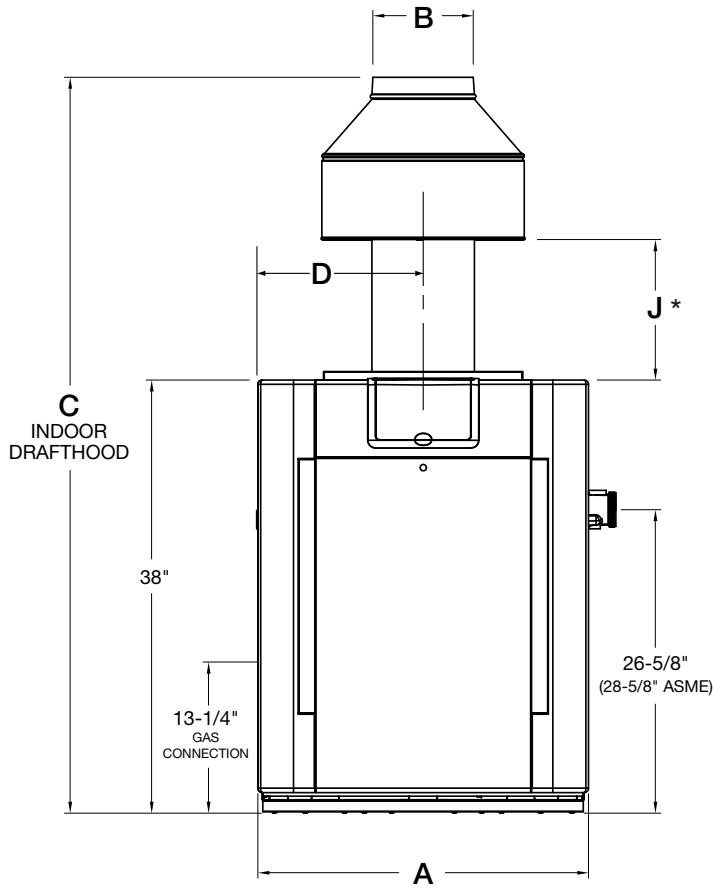

	Amp Draw	
	120 Volt	240 Volt
Digital	4	2

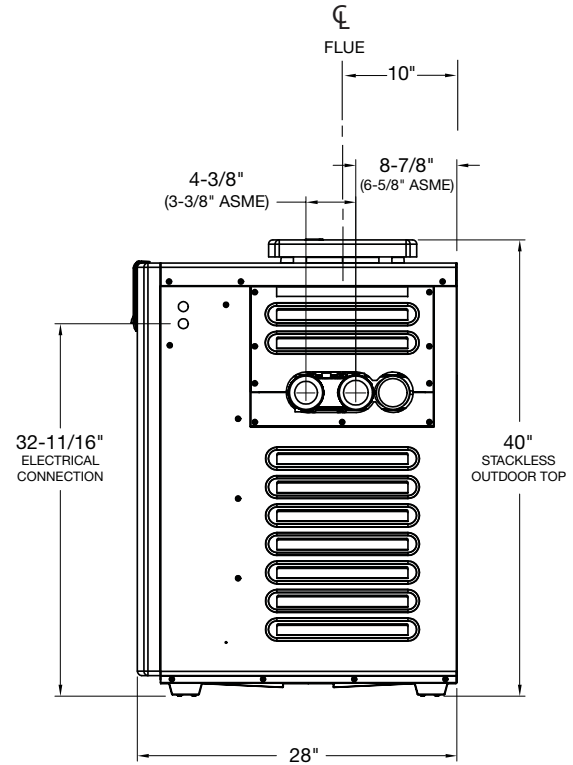

Heater Model	BTUH Input (000)	(A) Cabinet Width	(B) Flue Dia.	(C) Indoor Drafthood	(D)	(J) Min.	Gas Conn.	Water Conn.	Shipping Weights (lbs)		
									Standard Heater w/Stackless Top	ASME Heater w/Stackless Top	Indoor Draft-hood
R206A	199.5	20"	6"	61-5/8"	10.0"	11-3/4"	3/4"	2"	187	206	14
R266A	266.0	23"	7"	62"	11.5"	11"	3/4"	2"	210	229	16
R336A	332.5	26"	8"	63"	13.0"	10-5/8"	3/4"	2"	230	249	19
R406A	399.0	29"	9"	64-9/16"	14.5"	12-1/8"	3/4"	2"	249	268	21

Designation for a Digital or AFT heater using propane gas is "EP"; a Digital or AFT heater using natural gas is "EN".

Designation for a Millivolt heater using propane gas is "MP"; a Millivolt heater using natural gas is "MN".

Prefix "C" is for cast iron (ASME) headers; "P" is for plastic (polymer) headers.

Suffix "X" is for cupro-nickel tubing; "C" is for copper tubing.

EXAMPLE: **P-R406A-EN-X** = Plastic headers, 406 model size, digital, natural gas, cupro-nickel.

Reduce input 4% for each 1000 ft above sea level when installed above 2000 ft elevation.

For Canada, no de-rating is required for elevations up to 4500 ft

Plastic (polymer) headers cannot be used for ASME installations.

*Note: For outdoor stack, use J dimension in the table above for appropriate size PLUS six (6) inches.

SPECIFICATIONS AND DIMENSIONS

LO NO_x UNITS

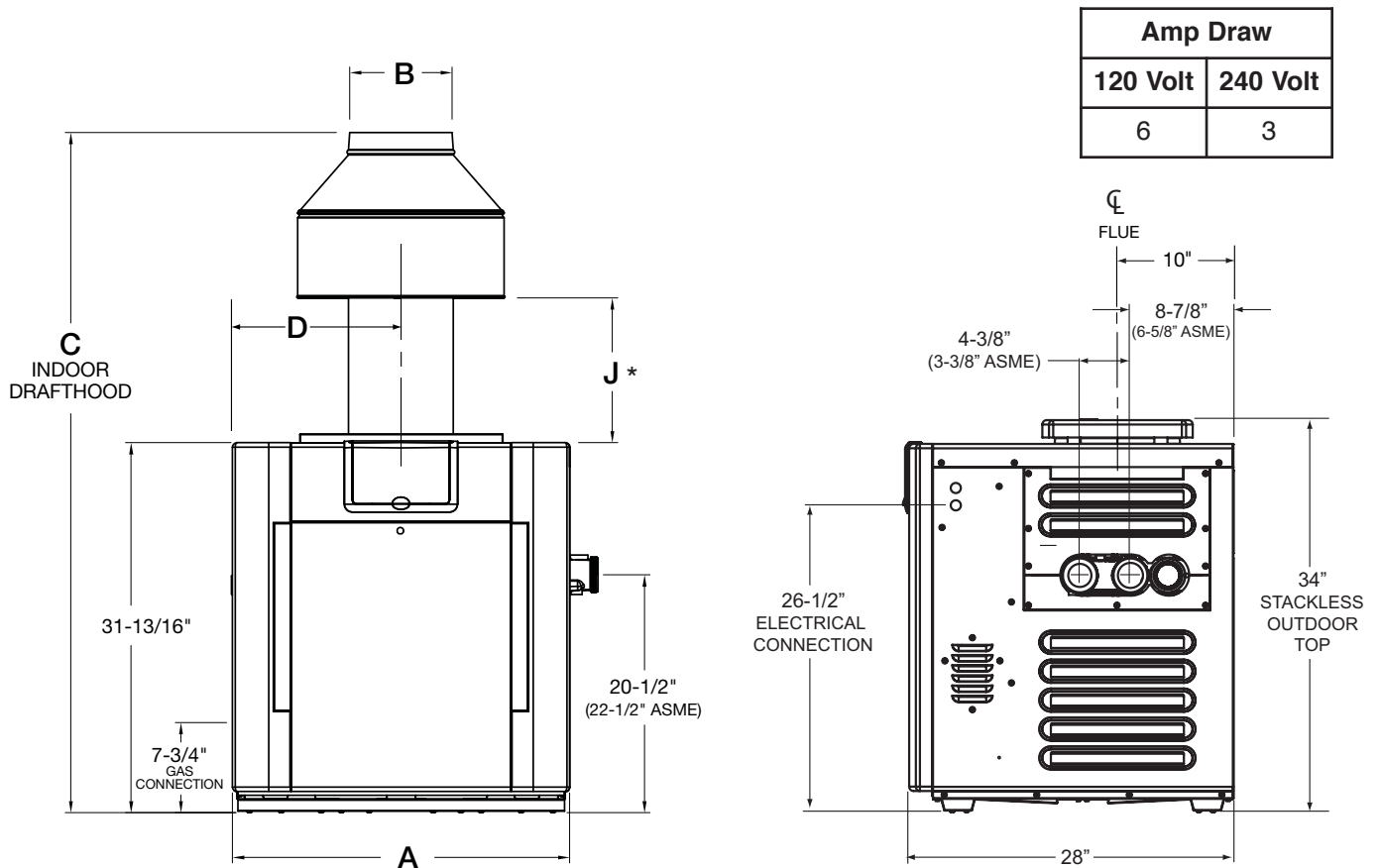

Heater Model	BTUH Input (000)	(A) Cabinet Width	(B) Flue Dia.	(C) Indoor Drafthood	(D)	(J) Min.	Gas Conn.	Water Conn.	Shipping Weights (lbs)		
									Standard Heater w/Stackless Top	ASME Heater w/Stackless Top	Indoor Draft-hood
R207A	199.5	20"	6"	55-5/8"	10.0"	11-3/4"	3/4"	2"	174	193	14
R267A	266.0	23"	7"	56"	11.5"	11"	3/4"	2"	197	216	16
R337A	332.5	26"	8"	57"	13.0"	10-5/8"	3/4"	2"	219	238	19
R407A	399.0	29"	9"	58-1/2"	14.5"	12-1/8"	3/4"	2"	237	256	21

Designation for a Digital or AFT heater using natural gas is "EN".

Prefix "C" is for cast iron (ASME) headers; "P" is for plastic (polymer) headers.

Suffix "X" is for cupro-nickel tubing; "C" is for copper tubing.

EXAMPLE: **P-R407A-EN-X** = Plastic headers, 407 model size, digital, natural gas, cupro-nickel.

For altitudes above 5,000 ft., consult the factory.

For Canada, no de-rating is required for elevations up to 4500 ft.

Plastic (polymer) headers cannot be used for ASME installations.

*Note: For outdoor stack, use J dimension in the table above for appropriate size PLUS six (6) inches.

**COMBUSTION AND VENTILATION AIR
(Indoor Units Only)**

The heater must have both combustion and ventilation air. Minimum requirements for net free air supply openings are one opening that is 12 inches from the ceiling for ventilation, and one opening that is 12 inches from the floor for combustion air as outlined in the latest edition of the National Fuel Gas Code, ANSI Z223.1(Canada-CAN/CSA-B149) and any local codes that may have jurisdiction.

A. All Air From Inside The Building:
Each opening shall have a minimum net free area as noted:

Model	Square Inches	Model	Square Inches
206/207	200	336/337	333
266/267	266	406/407	399

B. All Air From Outdoors:
When air is supplied directly from outside of building, each opening shall have a minimum net free area as noted:

Model	Square Inches
206/207	50
266/267	67
336/337	84
406/407	100

CAUTION: Combustion air must not be contaminated by corrosive chemical fumes which can damage the heater and void the warranty.

WARNING: Indoor heaters require a draffhood that must be connected to a vent pipe and properly vented to the outside. Failure to follow this procedure can cause fire or fatal carbon monoxide poisoning.

Vent piping the same size as the draffhood outlet is recommended, however, when the total vent height is at least 10 ft (draffhood relief opening to vent terminal), the vent pipe size may be reduced as specified in Chapter 10 of the National Fuel Gas Code, **ANSI Z223.1 (Canada - CAN/CSA-B149)**. As much as possible, avoid long horizontal runs of vent pipe and too many elbows. If installation requires horizontal runs, the vent pipe must have a minimum of 1/4 in. per ft rise and should be supported at not more than five foot intervals. Plumbers tape, criss-crossed, will serve to space both horizontal and vertical piping. Gas vents supported only by the flashing and extending above the roof more than five feet should be securely guyed or braced to withstand snow and wind loads. We recommend use of insulated vent pipe spacers through the roofs and walls. Another option for installation that requires horizontal runs is using the D-2 power vent kit option.

Power Vent Kit		
Model	120 VAC Part No.	240 VAC Part No.
206/207	010744	009832
266/267	010744	009832
336/337	010745	009833
406/407	010745	009833

The D-2 Power Vent operates with a positive vent static pressure and with a vent gas temperature that prevents excessive condensate production in the vent, and as such, is a CATEGORY III appliance.

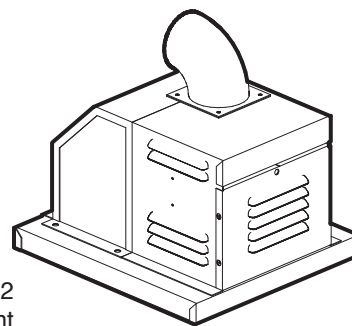

Optional Raypak D-2 Power Vent

For more information consult the D-2 Power Vent manual, (Catalog No. 6000.57.1).

The power vent assembly is a fan-assisted combustion system designed for application to models 206-407. The unit, when installed as directed, is capable of operating in applications such as through-the-wall venting and reduced horizontal and vertical vent pipe sizes in new and current installations. The unit is factory-wired for 240 VAC, with capability of rewiring for 120 VAC.

For protection against rain or blockage by snow, the vent pipe must terminate with a vent cap which complies with the local codes or, in the absence of such codes, to the latest edition of the National Fuel Gas Code, **ANSI Z223.1 (Canada - CAN/CSA-B149)**.

The discharge opening must be a minimum of 2 ft vertically from the roof surface and at least 2 ft higher than any part of the building within 10 ft. Vent stack shall be at least 5 ft in vertical height above the draft hood outlet. The vent cap location shall have a minimum clearance of 4 ft horizontally from, and in no case below, unless a 4 ft horizontal distance is maintained, from electric meters, gas meters, regulators and relief equipment.

The weight of the vent stack or chimney must not rest on heater draft hood. Support must be provided in compliance with applicable codes. The heater top and draft hood must be readily removable for maintenance and inspection. Vent pipe should be adequately supported to maintain proper clearances from combustible construction.

Type "B" double-wall or equivalent vent pipe is recommended. However single-wall metal vent pipe may be used as specified in the latest edition of the National Flue Gas Code **ANSI Z223.1 (Canada - CAN/CSA-B149)**.

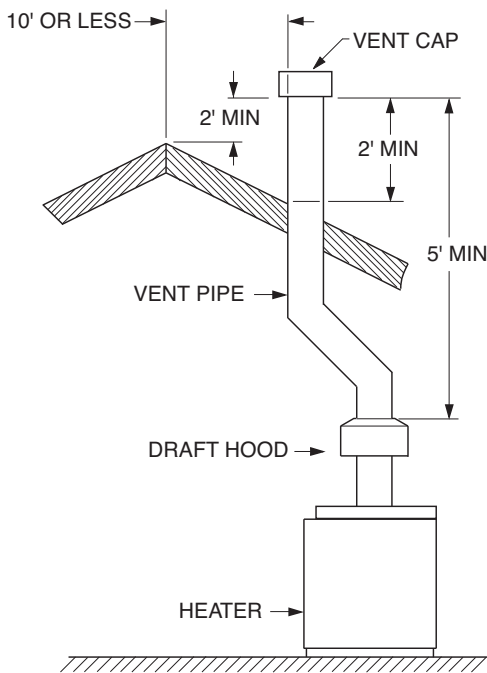

NOTE: With venting application of two or more heaters, contact the factory.

GAS SUPPLY CONNECTIONS

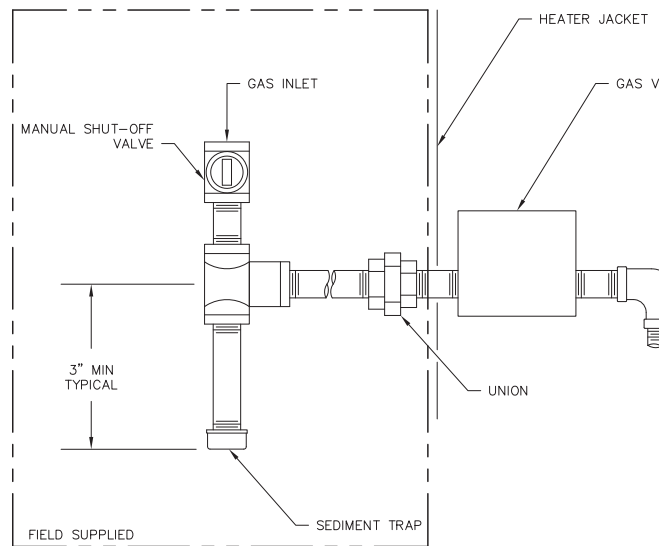

Gas piping must have a sediment trap ahead of the heater gas controls, and a manual shut-off valve located outside the heater jacket. All gas piping should be tested after installation in accordance with local codes.

CAUTION: The heater and its manual shut-off valve must be disconnected from the gas supply during any pressure testing of that system at test pressures in excess of 1/2 psi (3.45 kPa). Dissipate test pressure in the gas supply line before reconnecting the heater and its manual shut off valve to gas supply line. **FAILURE TO FOLLOW THIS PROCEDURE MAY DAMAGE THE GAS VALVE. OVER PRESSURIZED GAS VALVES ARE NOT COVERED BY WARRANTY.** The heater and its gas connections shall be leak tested before placing the appliance in operation. Use soapy water for leak test. **DO NOT** use open flame.

NOTE: Do not use Teflon tape on gas line pipe thread. A pipe compound rated for use with natural and propane gases is recommended. Apply sparingly only on male pipe ends, leaving the two end threads bare.

SUPPLY PRESSURES

A minimum of 7 in. WC and a maximum of 14 in. WC upstream pressure under load, and no-load conditions must be provided for natural gas or a minimum of 12 in. WC and a maximum of 14 in. WC for propane gas.

The gas pressure regulator is preset at 4.0 in. WC throughout for natural gas, and 10.5 in. WC for propane gas. The pressure at the gas valve, taken with a manometer, should be about 4.0 in. WC natural gas (3.1 in. WC for Lo NOx) and 10.5 in. WC propane gas. If an adjustment is needed, remove seal and turn adjustment screw clockwise to increase pressure or counter-clockwise to decrease pressure.

NOTE: Lo NOx gas valves are non-adjustable; settings are fixed by the manufacturer (Invensys/Robertshaw).

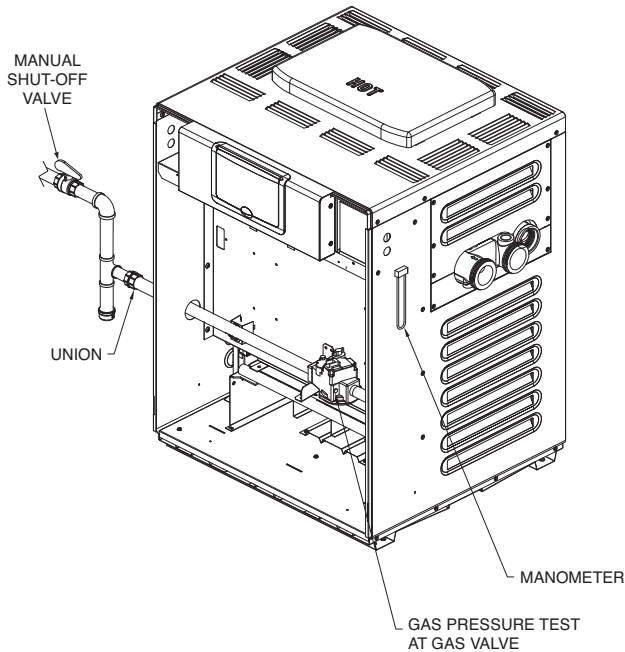

GAS PRESSURE ADJUSTMENT LOCATIONS

MILLIVOLT GAS VALVES

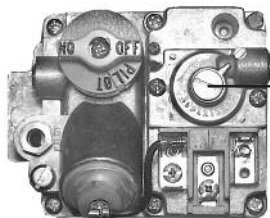

Gas Pressure Adjustment

Robertshaw 7000
(Heater Models 206-406)

ELECTRONIC IGNITION GAS VALVES

Gas Pressure Adjustment



Honeywell VR8304
(Heater Models 206-406 and 207-407)

ELECTRONIC IGNITION GAS VALVES-CONTINUED

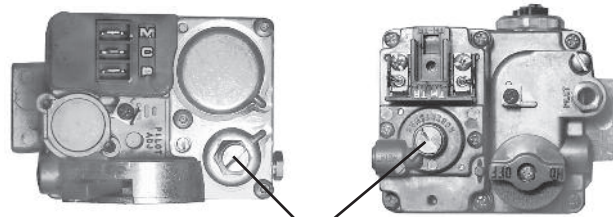

Gas Pressure Adjustment

Robertshaw 7200
(Heater Model 206)

Robertshaw 7000 BDER
(Heater Models 266-336)

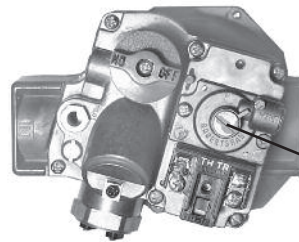

Gas Pressure Adjustment

Robertshaw 7000 DERHC
(Heater Model 406)

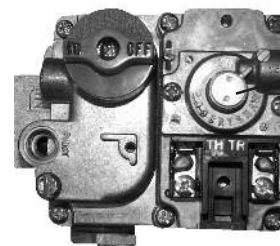

Non-Adjustable Gas Valve

Robertshaw 7000 BDERF
(Heater Models 207-407)

PIPE SIZING FOR GAS CONNECTIONS

Maximum Equivalent Pipe Length (ft)									
Natural Gas 1000 BTU/FT ³ 0.60 Specific Gravity @ 0.5 in. WC Pressure Drop									
Propane Gas 2500 BTU/FT ³ 1.53 Specific Gravity @ 0.5 in. WC Pressure Drop									
	Input	3/4"		1"		1-1/4"		1-1/2"	
Model	(KBTU)	N	P	N	P	N	P	N	P
206/207	199.5	25	60	90	215	360			
266/267	266.0	15	35	50	125	210	480	445	
336/337	332.5	10	20	30	80	140	320	290	
406/407	399.0	*	15	20	55	95	225	215	480

*A 3/4" gas line can be used for up to 5 ft maximum length from the gas valve in addition to the sediment trap.

FLOW RATES

MODEL	PIPE SIZE	MIN. GPM	MAX. GPM*
206/207	1-1/4"-1-1/2" - 2"	20	125
266/267	1-1/4"-1-1/2" - 2"	25	125
336/337	1-1/4"-1-1/2" - 2"	35	125
406/407	1-1/4"-1-1/2" - 2"	40	125

*When flow rates exceed maximum GPM an external auxiliary bypass valve is required. See external bypass valve section for details.

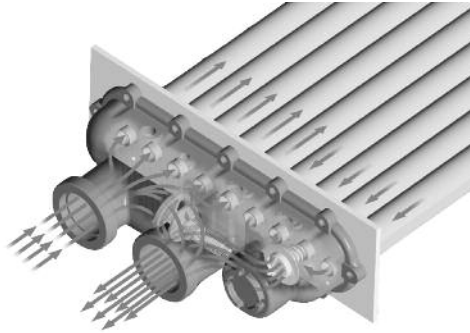

POLYMER HEADERS

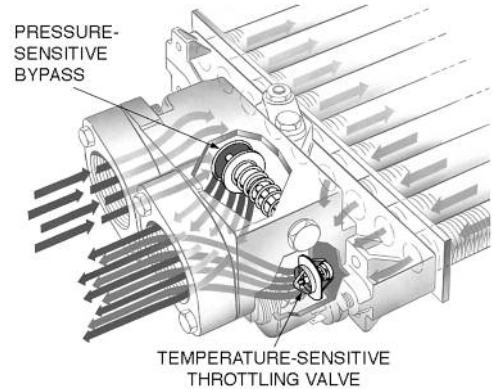

CAST IRON HEADERS (ASME)

HEAT EXCHANGER PRESSURE DROP TABLES

POLYMER HEADER (STANDARD MODELS)				
PLASTIC INTERNAL BAFFLE (Manufactured after 11/08)				
FLOW GPM	PRESSURE DROP (FT OF HEAD)			
	206/207	266/267	336/337	406/407
20	4.0			
25	4.0	4.6		
30	4.0	5.2		
35	4.0	5.8	5.2	
40	4.6	5.8	5.2	5.2
50	4.6	6.3	6.9	6.9
60	4.6	6.9	6.9	6.9
70	4.6	8.1	9.2	9.2
80	4.6	9.2	9.8	9.8
90	6.9	10.4	10.4	10.4
100	8.1	11.0	12.1	12.1
110	10.4	11.5	13.3	13.3
120	11.0	12.7	17.9	17.9
125	11.5	13.8	20.2	20.2

CAST IRON HEADER (ASME MODELS)				
FLOW GPM	PRESSURE DROP (FT OF HEAD)			
	206/207	266/267	336/337	406/407
20	1.8			
30	2.2	8.0		
40	2.5	9.0	9.0	9.0
50	2.7	9.8	9.8	9.8
60	3.3	10.5	10.5	10.5
70	4.3	11.0	11.0	11.0
80	5.5	11.5	11.5	11.5
90	6.8	14.0	14.0	14.0
100	8.2	17.0	17.0	17.0

POLYMER HEADERS (STANDARD MODELS)

Before attaching the 2-inch unions to the inlet/outlet header, make sure the O-rings are properly seated in the grooves. Use AquaLube or equivalent non-petroleum-based lubricant on the O-ring. **Hand tighten the unions.** Glue PVC piping directly to the unions.

INLET/OUTLET HEADER - POLYMER

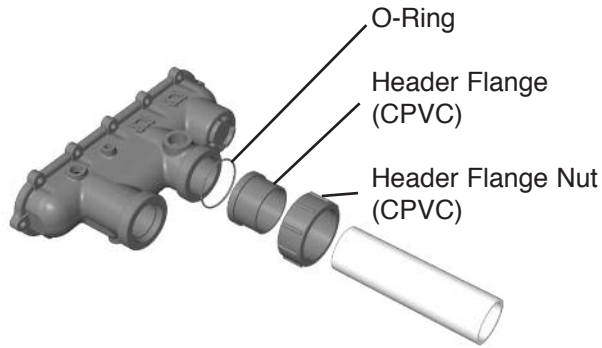

High-temperature CPVC header flanges and header flange nuts are provided. If there is any possibility of back-siphoning when the pump stops, it is suggested that a check valve (or valves) also be installed in the system.

CAST IRON HEADERS (ASME MODELS)

Heater must be located so that any water leaks will not damage the structure of adjacent area. High temperature 2" plastic pipe (CPVC) may be threaded directly into the header flanges. This is not the same as the Schedule 80 PVC pipe which is also gray. PVC may be used immediately after the supplied CPVC adapters.

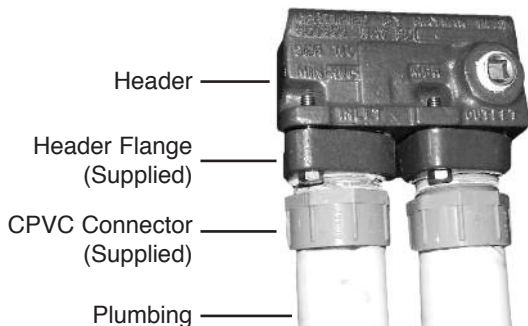

WARNING: NEVER install PVC directly into header flanges. Use the 2" CPVC adapter supplied loose with the heater.

NOTE: The State of Texas requires the addition of a flow switch and T&P gauge on ASME installations. Kit # 012011 can be ordered that will allow a standard ASME unit to comply with the Texas code requirements.

DO NOT use petroleum-based assembly fluids (such as petroleum jelly or lubricating oil). If assembly lube is

required, use a silicon base such as AquaLube etc.

There are two sets of flange gaskets supplied with your heater. Use the appropriate gaskets for all your heater connections. Discard unused set.

GASKET DESIGN #1: Accepts 1-1/2" copper tube or 1-1/4" galvanized pipe as a slip connection.

GASKET DESIGN #2: Accepts 2" copper tube as a slip connection. The flange is threaded for 2" screw in pipe connections. Also used with the 2" CPVC adapters.

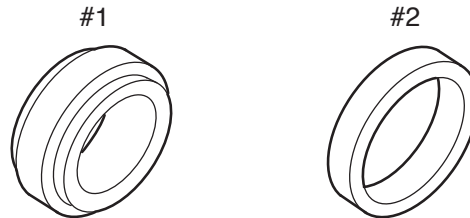

INLET/OUTLET HEADER - ASME

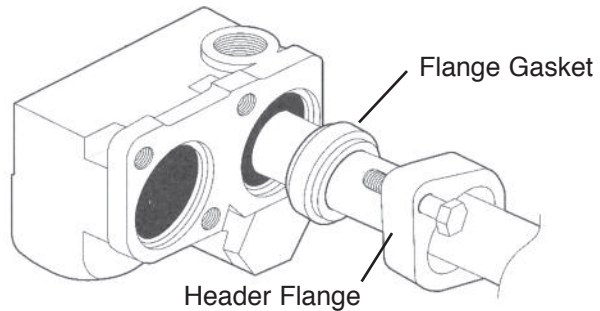

UNITHERM GOVERNOR OPERATION

CAUTION:

The patented Unitherm Governor is a thermostatic mixing valve specifically designed to maintain constant heater internal temperature between 105° and 115°F despite continually changing flow rates from the filter and changing pool temperatures. This narrow range is needed to prevent damaging condensation on the burners which will occur if the heater runs for any length of time below 100°F. It is also needed to inhibit scale formation in the tubes by maintaining temperatures well below accelerated scaling temperatures.

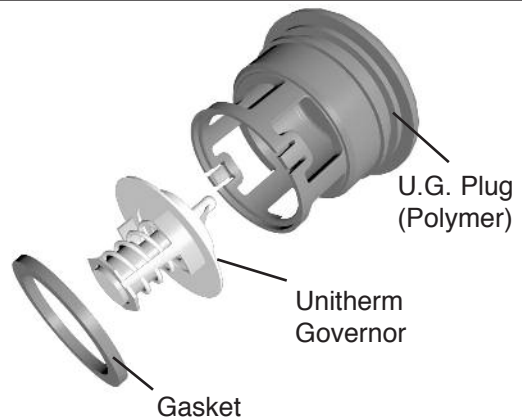

INTERNAL AUTOMATIC BYPASS VALVE

In addition to the Unitherm Governor, a built-in automatic bypass valve is provided in the in/out header. While the Unitherm Governor responds to the changes in water temperature in the heater, the internal bypass valve automatically responds to changes in water pressure in the piping system. Proper amount of water flow is maintained through the heater under varying pressures dictated by the conditions of the pump and filter.

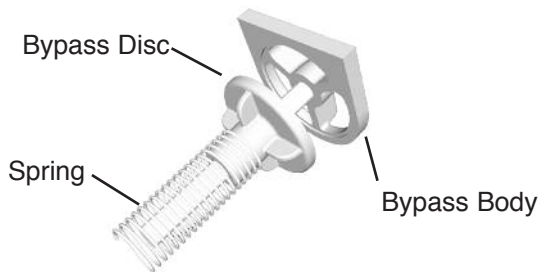

EXTERNAL AUXILIARY BYPASS VALVE

(Where Required)

An auxiliary bypass valve should be used when flow rates exceed 125 GPM. Usually a high-performance pump size larger than two horsepower will exceed this flow rate. This valve is required to complement the function of the automatic bypass valve, particularly when starting the heater in winter or early spring when the spa or pool temperature is below 50°F. It also serves to eliminate needless pressure drop through the heater and accompanying reduction in the flow rate to the spa jets, etc.

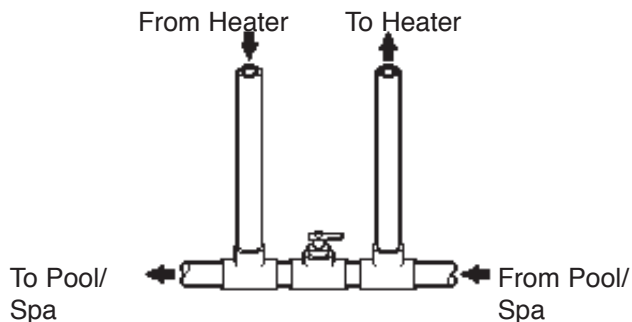

AUXILIARY BYPASS VALVE
(DO NOT USE GATE VALVE)

AUXILIARY BYPASS VALVE ADJUSTMENT

To set bypass: With clean filter, adjustment is made by feeling the inlet and outlet pipes at the heater. Outlet pipes should be slightly warmer than inlet and comfortable to the touch. If pipe is hot, close bypass; if cold, open bypass.

PRESSURE RELIEF VALVE INSTALLATION

To conform to local building codes, it may be necessary to install a pressure relief valve. A 3/4" pressure relief valve, having a capacity equal to the BTUH output of the model to be installed, is recommended for this heater. The maximum acceptable pressure relief valve setting is 125 psi.

A 3/4" NPT connection is provided in the Polymer header for installation of a pressure relief valve. The valve shall be installed in a vertical position. Do not overtighten. Install pressure relief valve hand tight plus 1/2 turn.

POLYMER HEADER (STANDARD MODELS)

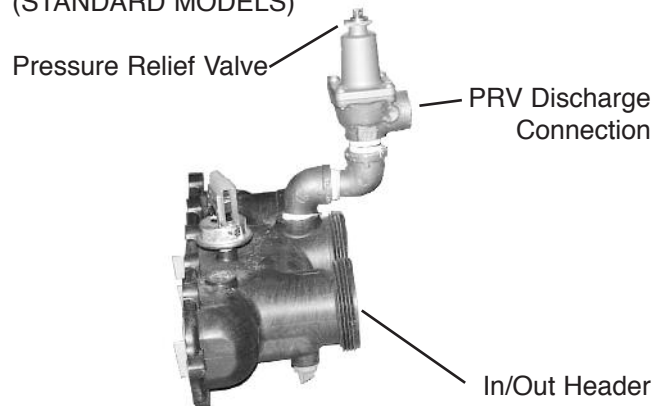
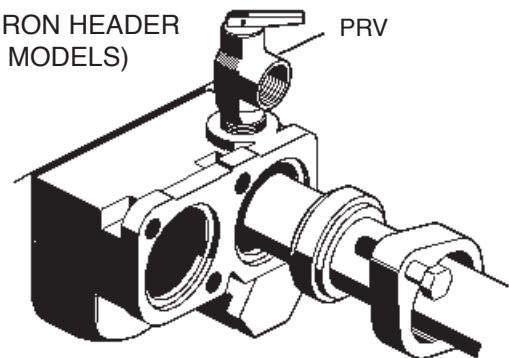

Fig. #2004

A 3/4" NPT connection is provided in the header for installation of a pressure relief valve. The valve shall be installed in a vertical position.

CAST IRON HEADER (ASME MODELS)



NOTE: To avoid water damage or scalding due to valve operation, drain pipe must be connected to valve outlet and run to a safe place of discharge. Drain pipe must be the same size as the valve discharge connection throughout its entire length and must pitch downward from the valve. No shut-off valve shall be installed between the relief valve and the drain line. Valve lever should be tripped at least once a year to ensure that waterways are clear.

PLUMBING—WATER CONNECTIONS

Single Pool Heater Installation

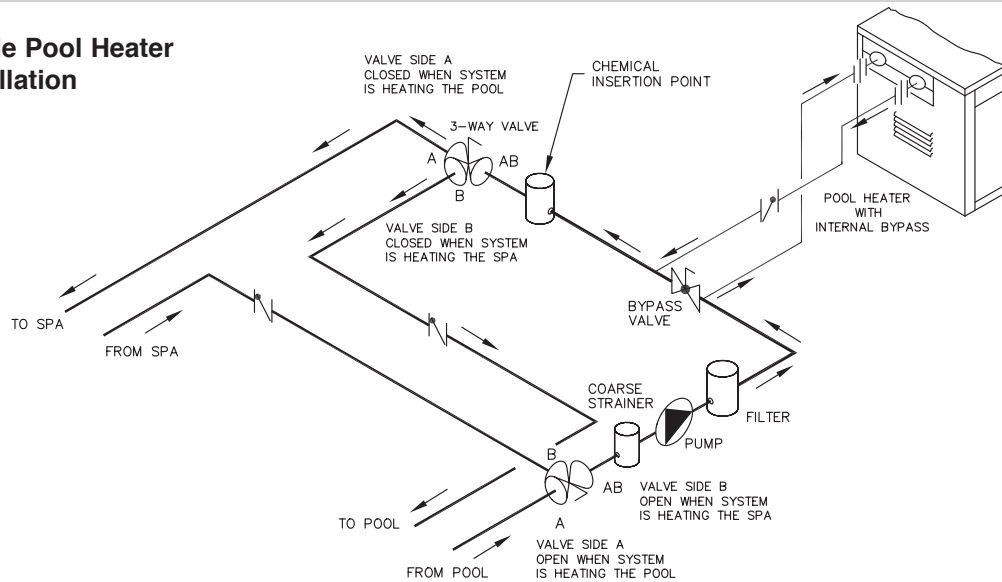

THIS DIAGRAM IS RAYPAK'S RECOMMENDATION AND IS NOT INTENDED TO REPLACE AN ENGINEERED PIPING SYSTEM BY A PROFESSIONAL ENGINEER.

KEY	
	ISOLATION VALVE
	BALL VALVE
	PRESSURE RELIEF VALVE
	PUMP
	UNION
	CHECK VALVE

Multiple Pool Heater Installation

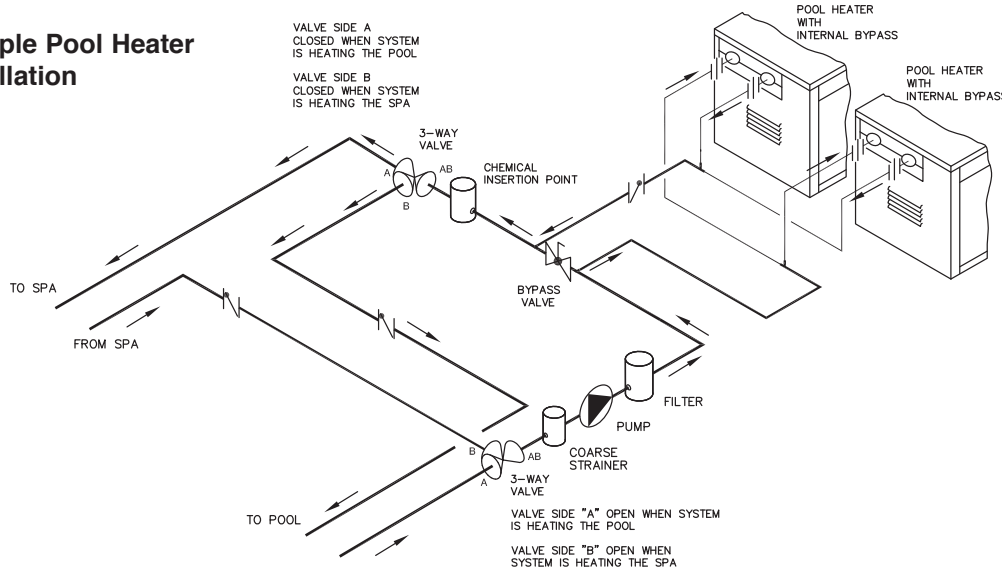

THIS DIAGRAM IS RAYPAK'S RECOMMENDATION AND IS NOT INTENDED TO REPLACE AN ENGINEERED PIPING SYSTEM BY A PROFESSIONAL ENGINEER.

The heater requires water flow and positive pressure to fire and operate properly. It must therefore be installed downstream of the discharge side of the filter pump. A typical installation is plumbed as follows:

1. The inlet side of the filter is plumbed directly to the discharge side of the filter pump;
2. The outlet side of the filter is then plumbed to the inlet of the heater; and
3. The outlet of the heater is plumbed to the return line to the pool or spa. The pump, filter and heater are thus plumbed in series (Salt generators and chemical feeders must be down stream of the pool heater).

Plumbing from the heater back to the pool or spa must not have any valves or restriction that could prevent flow when the pump is operating.

CAUTION: An additional source of heated water, e.g. a solar system, must be connected to the main line ahead of the heater inlet pipe in order for it to act as the primary heat source. If the primary system provides adequate heat to maintain set-point, the heater will not fire. Be advised that the control panel will then display sensed water temperatures downstream of the primary heating system, rather than the temperature of the water exiting the pool.

Heater must be located so that any water leaks will not damage the structure of adjacent area. PVC pipe may be glued directly into header unions (Standard models only).

HEAT EXCHANGER REVERSAL PROCEDURE - STANDARD MODELS

1. Remove right and left side access panels (Figure 1).
2. Disconnect wires at high limit, AGS (automatic gas shut-off), and pressure switch on the in/out header (Figure 2).
3. **Digital/AFT Models:** Remove the thermostat temperature sensor by loosening the compression fitting nut (Figure 3). Re-route the sensor to the left side of the heater.
4. **Millivolt Models:** Remove the temperature sensor bulb and retainer clip from the sensor well (Figure 4). Re-route the sensor bulb to the left side of the heater.
5. Remove (12) bolts holding the inlet/outlet and return headers to the tube sheets. Clean off tube sheet area where the gasket seats. Also clean off the header and the gasket. Apply a non-petroleum-based lubricant to the gasket such as AquaLube. Re-attach the headers to the opposite sides, making sure they are installed in an upright position (Figure 5). **Do not over tighten.** Torque should not exceed 7 ft/lb.
6. Reconnect high limit, AGS, and pressure switch wires.
7. **Digital/AFT Models:** Insert the temperature sensor into the compression fitting, so that the sensor is flush with the top of the fitting. Tighten 1/2 turn past hand-tight.
8. **Millivolt Models:** Insert sensor bulb and retainer clip into sensor well.
9. Allow for water flow through the heater and check for leaks.
10. Re-attach access panels to the opposite sides.

For ASME Models call your factory representative.

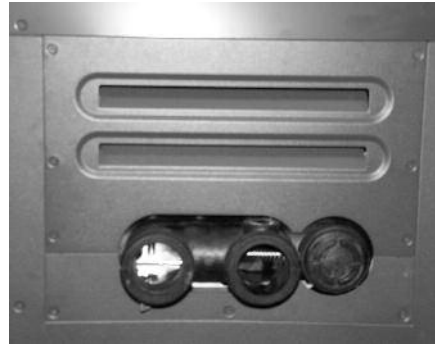

Fig. #1

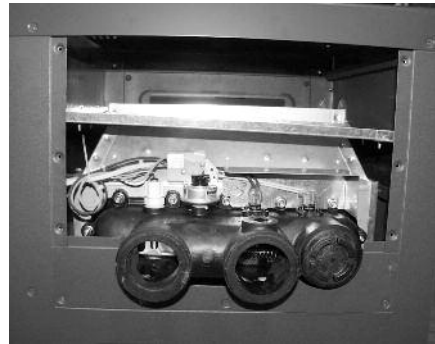

Fig. #2

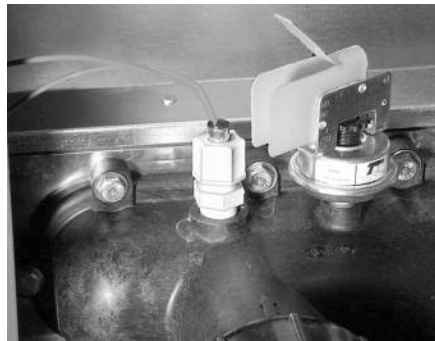

Fig. #3



Fig. #4

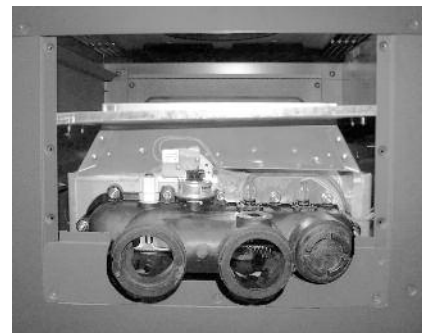

Fig. #5

ELECTRICAL WIRING

NOTE: If it is necessary to replace any of the original wiring, use 105°C wire or its equivalent, and/or 150°C wire or its equivalent, like the original wiring.

MILLIVOLT MODELS

The Millivolt models are equipped with a self-generating electrical system in which the electrical current is provided by a pilot generator. No external electrical connections are required.

When installing a remote switch, do not exceed 10 ft of wiring from the heater. Use 18-gauge stranded wire.

DIGITAL AND ADVANCED FLAME TECHNOLOGY (AFT) MODELS

WARNING:

Heaters are factory-wired for **240 VAC** power supply. **DO NOT attempt to operate at 208 VAC.**

NOTE: Lo NOx heaters manufactured November 2010 (serial number beginning with "1011") and later are equipped with Advanced Flame Technology (AFT) boards. Lo NOx heaters manufactured before November 2010, and all atmospheric heaters are equipped with Digital PC boards.

The standard field-wiring connection is on the right side of the heater.

To wire the heater from the left side, follow these steps :

1. Remove the two (2) screws that hold the front door to the heater. Remove and set aside door for better access to wiring.
2. Remove the four (4) screws that hold down the junction box to the sway brace.
3. Remove the transformer cover located on the far right by removing one (1) screw.
4. Remove the two (2) screws that hold down the transformer.
5. Remove the one (1) screw that holds down the ground wires.
6. Disconnect P6 connector from PC board.
7. Remove transformer from its current location and relocate it on the far left side of the heater.
8. Re-route all high-voltage wires and ground wires through the left jacket side of heater.
9. Re-install P6 connector, ground wires (SPG), transformer, junction box, front door, and plug right side with the left side's grommet plug.

NOTE: 7/8" dia. holes not utilized on jacket and control box can be used for fireman switch, auxiliary control interface or power vent (D-2) wiring.

CAUTION: Heater must be electrically grounded and bonded. Bonding lug is provided loose with the heater. Install bonding lug on lower right or left side of jacket as necessary for bonding the heater. Mounting hole is provided on the jacket.

NOTE: Failure to ground the heater electrically could affect the heater's electronics.

The Electronic Intermittent Ignition Device automatically lights the pilot and main burners upon a call for heat. The heater is supplied with a dual-voltage transformer for 120 VAC or 240 VAC input power hookup.

NOTE: See page 42 for further instructions if using a time clock/fireman's switch.

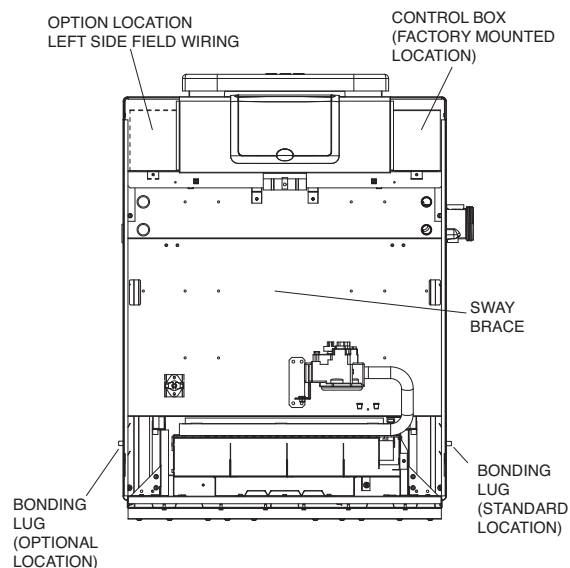

ATMOSPHERIC
Wiring locations

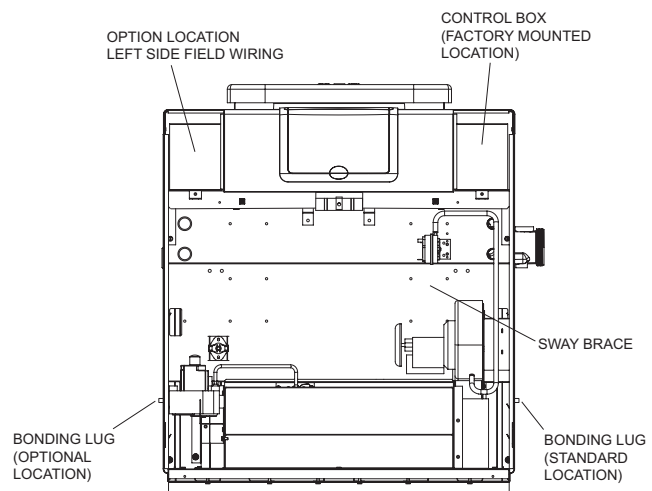

LO NOx
Wiring locations

TRANSFORMER WIRING

120 VAC WIRING

For 120 VAC input power to the unit, connect the black wire to the “L1” or hot leg of the power supply. Connect the white wire to the “Ret” or neutral leg of the power supply. Attach the wire nut to the red wire. **There should be no connection to the red wire for 120 VAC operation.** For Lo NOx pool heaters attach a wire nut to each red wire independently.

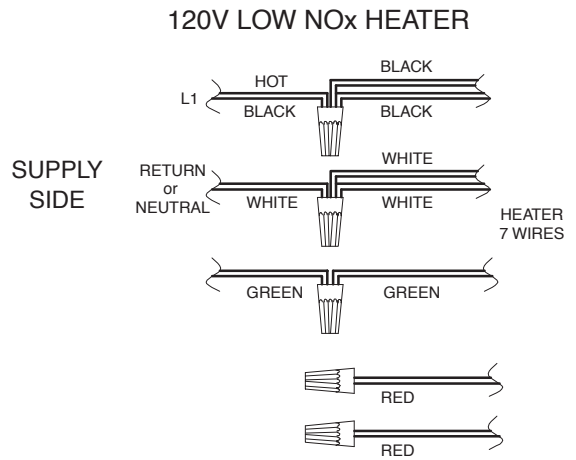
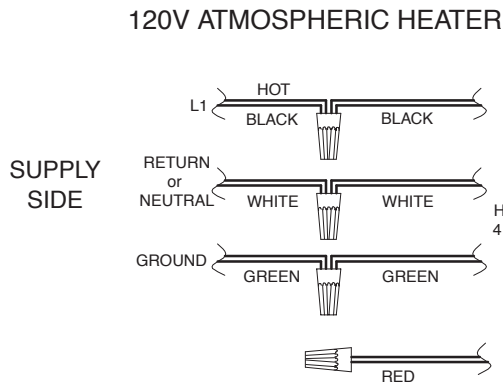

240 VAC WIRING

For 240 VAC input power to the unit, connect the black wire to the “L1” or hot leg of the power supply. Connect the red wire to the “L2” or second hot leg of the power supply. Attach the wire nut to the white wire. **There should be no connection to the white wire for 240 VAC operation.** For Lo NOx pool heaters attach a wire nut to each white wire independently.

WARNING: DO NOT attempt to operate the heater at 208 VAC.

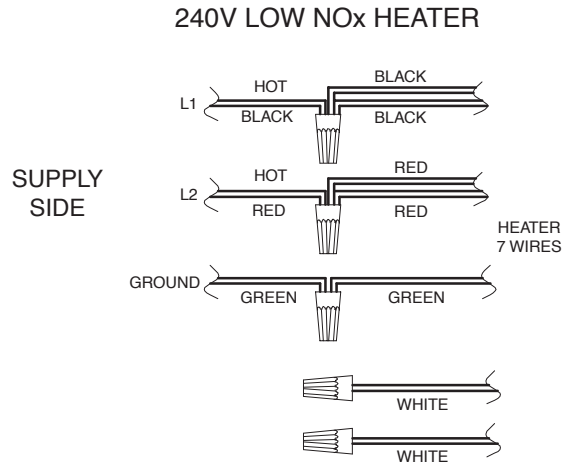
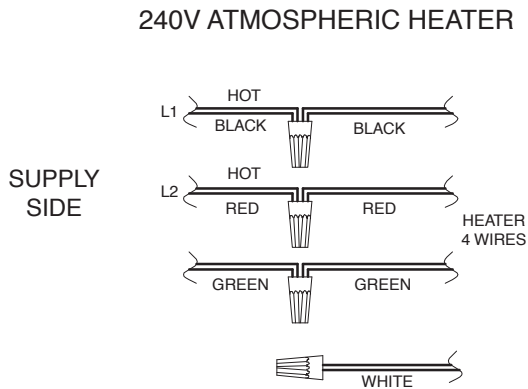

Heater must be electrically grounded and bonded in accordance with local codes, or, in the absence of local codes, with the latest edition of the National Electrical Code, ANSI/NFPA 70. (Canada - Canadian Electrical Code, CSA C22.1, Part 1 and Part 2.)

NOTE: If the transformer’s primary side is wired for 120 VAC and 240 VAC is applied, damage to the transformer and PC board may result. Such damages are not covered under manufacturer’s limited warranty.

NOTE: Input power to the heater (120 or 240 VAC) can be supplied from the load (pump) side of time clock or directly from the GFCI power source. **It is preferred that full-time power be supplied to the heater from the GFCI power source, and that the heater be controlled by the fireman’s switch connection or using a two or three-wire remote. See page 36 and pages 40-42.** If using a switched GFCI power source, the heater could display false service indicators on the display panel if the pump is turned off.

WIRING DIAGRAM - MILLIVOLT (MECHANICAL THERMOSTAT)

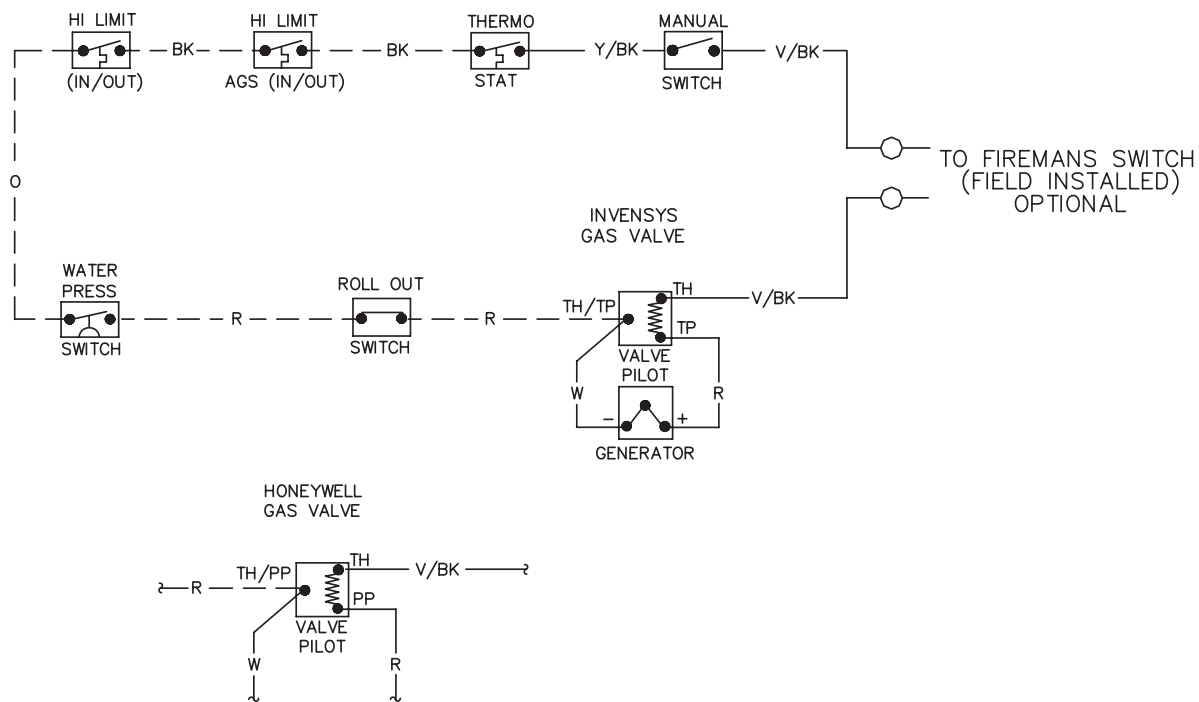

REPLACE WIRING WITH 105°C WIRE OR 150°C WIRE AS NOTED

WIRING DIAGRAM STANDING PILOT MILLIVOLT

HEATER INPUTS: 199,500 THRU 399,000 BTUH

HEATER SIZE: 206-406 HEATER TYPE: P

KEY	
—————	105°C
- - - - -	150°C
○	WIRE NUT
BK	- BLACK
BR	- BROWN
BL	- BLUE
G	- GREEN
O	- ORANGE
R	- RED
V	- VIOLET
W	- WHITE
Y	- YELLOW
V/BK	- VIOLET WITH BLACK STRIPE
Y/BK	- YELLOW WITH BLACK STRIPE

WIRING DIAGRAM - DIGITAL MODELS - ATMOSPHERIC

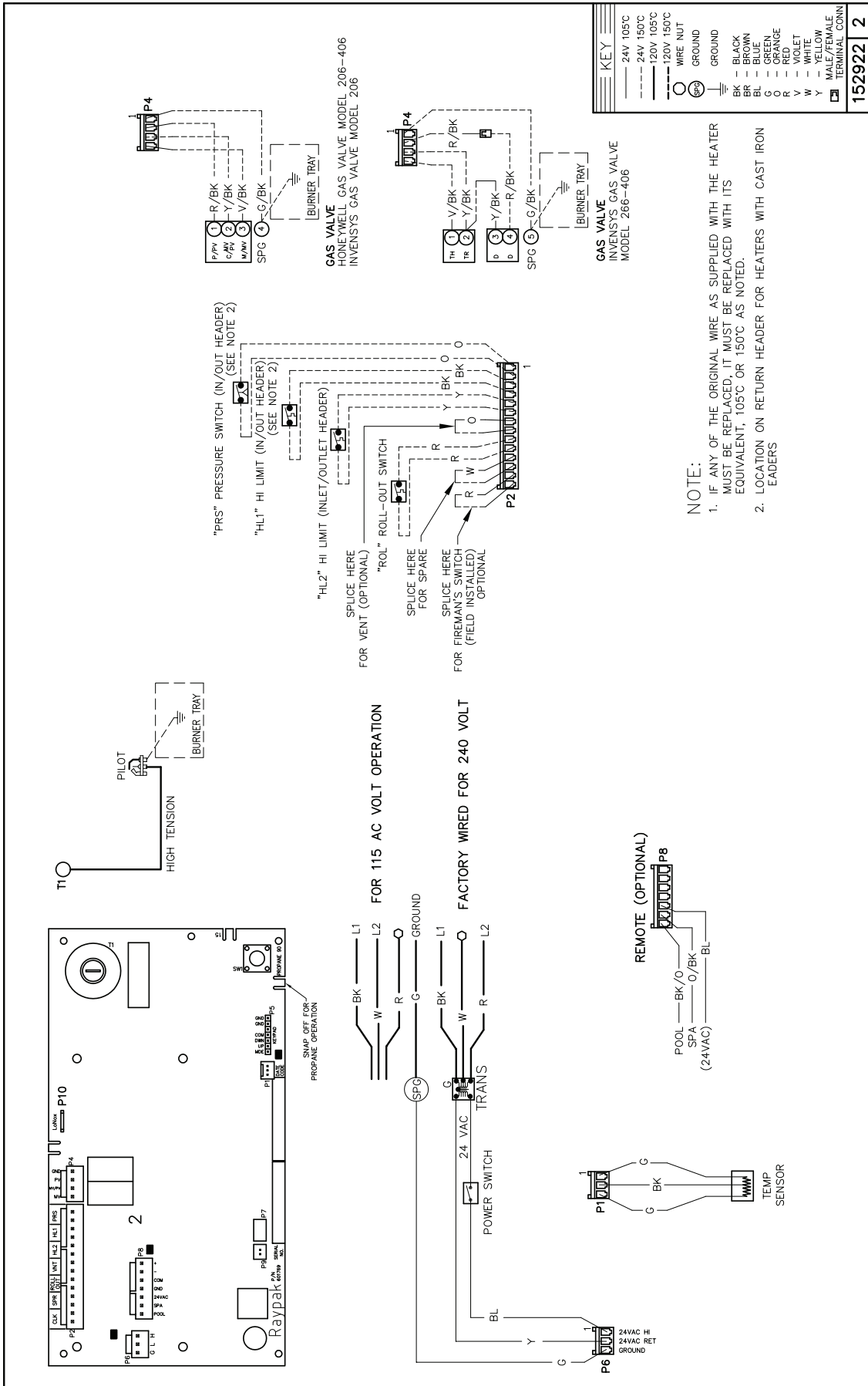

WIRING DIAGRAM - DIGITAL AND AFT MODELS - LO NOx

Raypak Digital PC Board,
Part No. 601769

Raypak AFT Board,
Part No. 601944

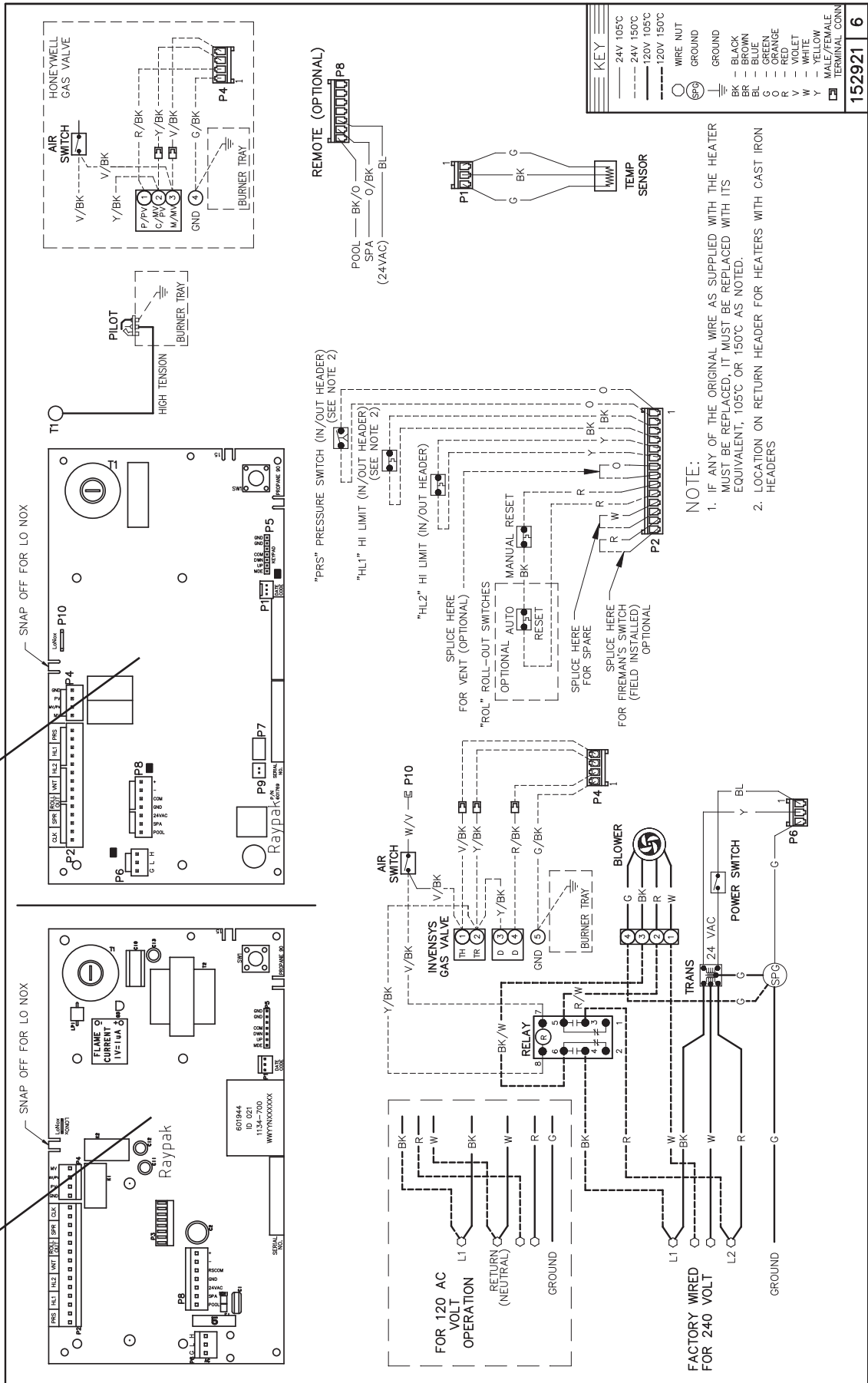

SECTION 4 - SERVICING INSTRUCTIONS

GENERAL LOCATION OF CONTROLS

ATMOSPHERIC

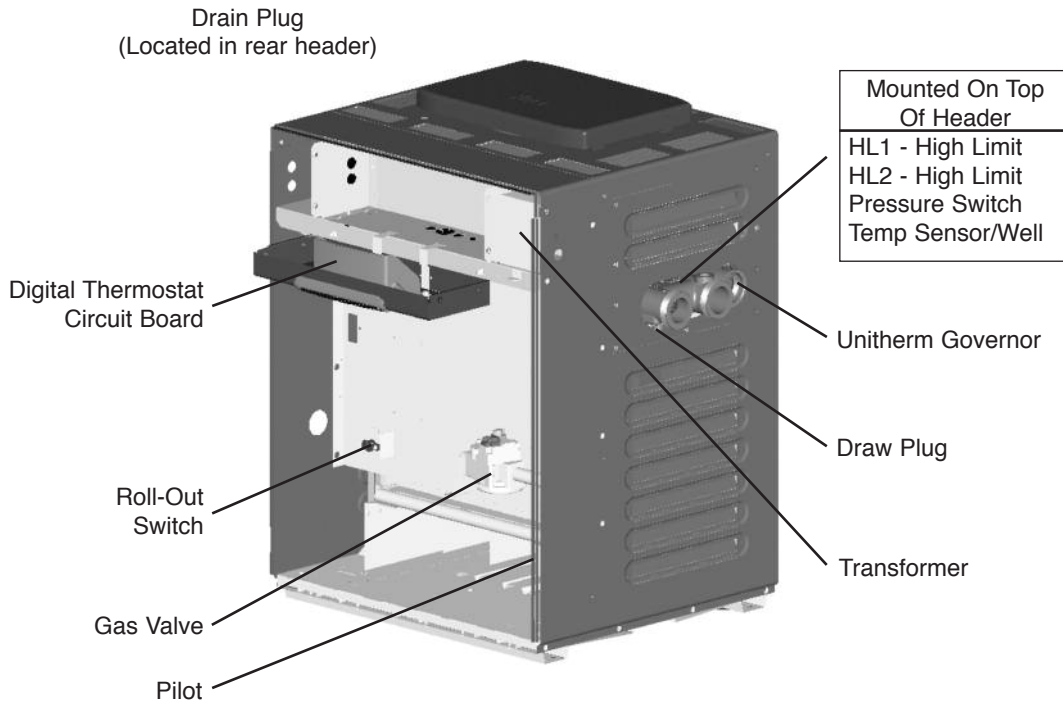

LO NOx

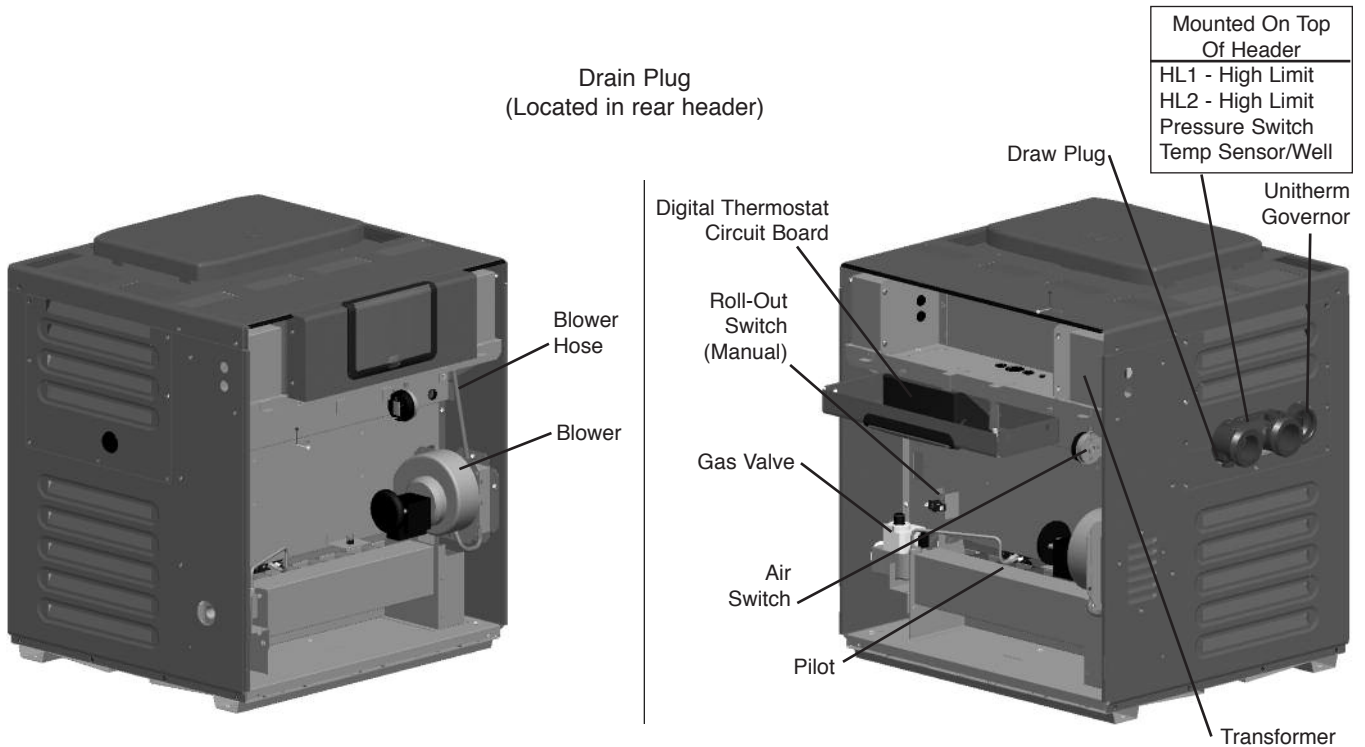

CONTROL PANEL REMOVAL

1. Remove screw from front door. Set aside door for serviceability.

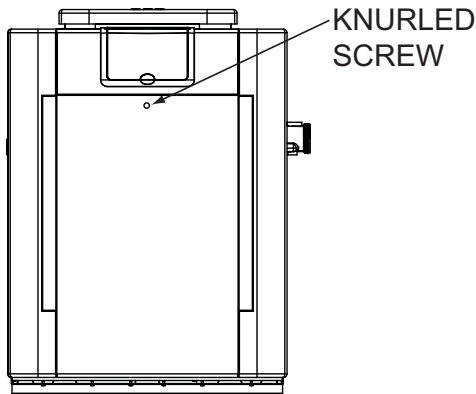

2. Remove (4) screws from sides of control panel.
3. Rotate control panel down until panel stops. Do not force.

NOTE: Caution must be used to not damage controls or wiring.

CONTROL ADJUSTMENTS - DIGITAL AND ADVANCED FLAME TECHNOLOGY (AFT) MODELS

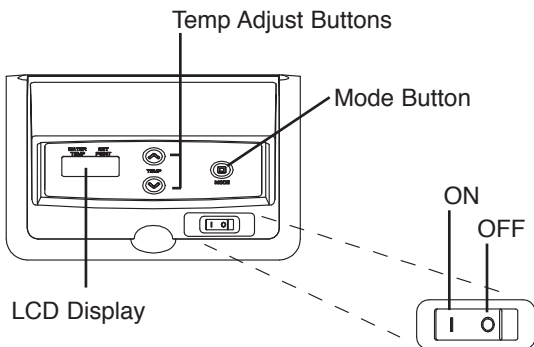

CONTROL ADJUSTMENTS - MILLIVOLT MODELS

The water temperature is controlled by the heater thermostat on the upper front panel of the heater. The control center contains an On/Off switch and one thermostat.

The thermostat is fitted with a means of limiting the upper temperature limit below the maximum level. The knob stop adjustment ring illustrated below is adjustable by loosening the set screw, rotating the knob stop ring to the desired location and re-tightening the set screw.

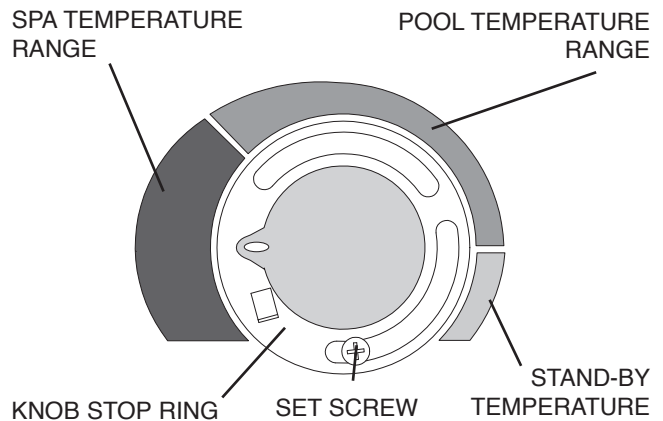

KNOB STOP SHOWN ABOVE IS IN THE SPA TEMPERATURE RANGE

THERMOSTAT OPERATION - DIGITAL BOARD

Thermostat operation

Your heater is equipped with a microprocessor-controlled thermostat that controls the pool or spa temperature by measuring the temperature of the water entering the heater. It monitors the water temperature and turns the heater on when it senses that the water temperature is below the set point. It is normal to experience small fluctuations in the return water temperature during the operation of the heater. The thermostat is calibrated with a very narrow tolerance to ensure accuracy of the set temperature. Thus, **slight fluctuations in water temperature may cause your heater to cycle on and off frequently. This is not a problem.** It will not harm the heater nor interfere with the thermostat's ability to precisely control the temperature of the pool or spa.

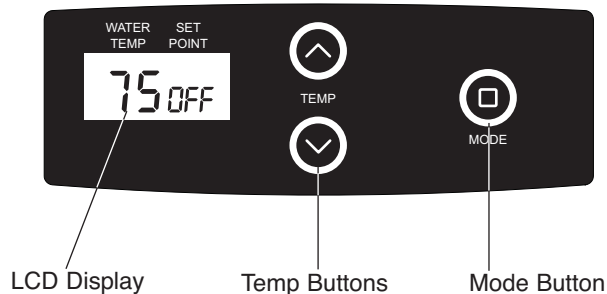

LCD Display

Temp Buttons

Mode Button

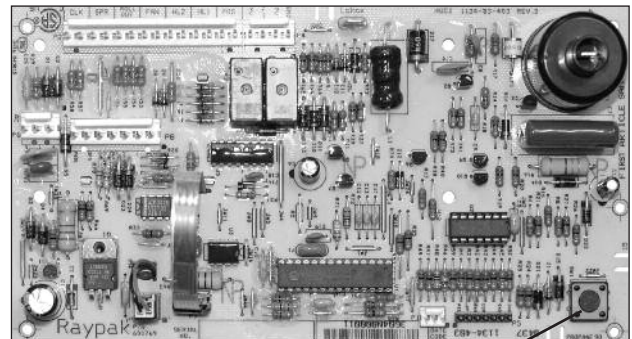

Program button

The pool heater thermostat, located on the upper front panel of the heater, controls the pool/spa water temperature. This control center contains a mode button, up and down temperature adjustment buttons, and an LCD display.

Mode Button

The MODE button functions as a means to turn the heater off or on in either the POOL or SPA setting. The LCD display indicates the mode the heater is in and the actual water temperature.

Temp Buttons

If the heater is in POOL or SPA mode, the desired water temperature (SETPOINT) will also be displayed and may be changed using the UP or DOWN buttons. A manual toggle switch is also provided right below the MODE button to allow the heater to be turned off.

Operation

In the POOL or SPA modes, the actual water temperature is displayed along with the desired water temperature (SETPOINT). If the heater is firing, a flame icon will be visible.

To adjust the setpoint temperature, make sure the control is in the appropriate mode (POOL or SPA) and push the UP or DOWN buttons.

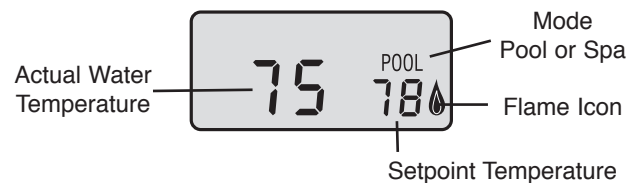

DISPLAY CALL FOR HEAT

Fault History File

To access the Fault History File, press the **Mode** button until the display reads **OFF**. Press both the UP and DOWN buttons at the same time (5-7 seconds) until the display changes and shows a fault code. The latest fault code will be displayed first. By pressing the UP or DOWN buttons, a series of faults will be displayed from the last (highest number) to the first (lowest number). If the buttons are not touched after 5-7 seconds, the display will return to its normal operation.

Program Button

- 1) To access the program screen, press the Mode button until the display reads **OFF**. Remove the four screws holding the control cover on. Swing control panel down so the back side of the board is visible (see page 31). Locate the Program Mode button as shown in the figure on page 33. Press the program button (5-7 seconds) until **SETdef** appears on the digital display. Release the program button.
- 2) Press the **Mode** button sequentially until the desired program event is reached. There are 5 different events that can be programmed. They appear in the sequence listed below:



Resets board to factory default settings.

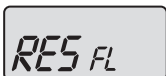

Resets faults in the History File.



Change from Fahrenheit to Celsius.



SPA setpoint maximum adjustment.



POOL setpoint maximum adjustment.

SETdef – Default Settings

Refer to step one above to access the program screen. **SETdef** should appear on the screen. If not, press the **Mode** button until **SETdef** appears on the digital display. Press and hold both UP and DOWN buttons for 5-7 seconds until 3 dashes (---) appear. This operation resets the operating program to its factory default values. Both the POOL and SPA setpoints will revert to 65°F (18.5°C) and both POOL and SPA maximum temperature settings will be 104°F (40.0°C). Once this is done, reassemble the control panel.

RESfl – Reset Fault History

Refer to step one above to access the program screen. Press the **Mode** button until **RESfl** appears on the digital display. Press and hold both UP and DOWN buttons for 5-7 seconds until 2 dashes (--) appear. This operation resets the Fault History file to "0" and clears all the stored faults. Once this is done, reassemble the control panel.

F/Cfff – Fahrenheit to Celsius

Refer to step one above to access the program screen. Press the **Mode** button until **F/Cfff** appears on the digital display. The digital display is capable of displaying Celsius as well as Fahrenheit temperatures. The UP or DOWN buttons will select "F" or "C" on the temperature display. Choose the desired temperature scale. Once this is done, reassemble the control panel.

SETspa 104 – SPA Set Point Maximum Adjustment

Refer to step one above to access the program screen. Press the **Mode** button until **SETspa 104** appears on the digital display. Using the UP and DOWN buttons will change the Maximum Temperature Setting to your desired value. The control can be set for a maximum of 107°F. Once this is done, reassemble the control panel.

SETpool 104 – POOL Set Point Maximum Adjustment

Refer to step one above access into the program screen. Press the **Mode** button until **SETpool 104** appears on the digital display. Using the UP and DOWN buttons will change the Maximum Temperature Setting to your desired value. The control can be set for a maximum of 107°F. Once this is done, reassemble the control panel.

NOTE: The LCD temperature display may not agree with the temperature reading of your pool or spa thermometer. The heater reads the water temperature at the inlet. Due to the circulation characteristics of any pool or spa, the water temperature at the inlet to the heater may differ from that observed at a given location in the pool or spa.

DIAGNOSTICS

The digital thermostat models are equipped with on-board diagnostic controls. If there is a safety fault, a fault code will be displayed along with a service indication.

If the PRS fault code is displayed, it indicates that there is insufficient water flow through the heater. Make sure the pool filter and pump strainer are clean before calling a service representative.



READING A FAULT

The word "SERVICE" will flash on and off if the PC board detects a known fault. The fault will be displayed in three big letters on the lower left of the display.



STATUS CODES

Display	Definition
CFH	Call for heat
CLK	Time clock
EOL	End of line test (Factory Use Only)
LON	Lo NOx Unit
OFF	Off mode
PRO	Propane gas configured
REM	Remote control activated
SPK	Spark
SPR	Spare fault code indicator

PROGRAM MODES

Display	Definition
CCC	Celsius setting
F/C	Change from Fahrenheit to Celsius
FFF	Fahrenheit setting
RES	Reset defaults
SET	Set point max adjustment

FAULT CODES

Display	Definition
BD1	Board failure
EEP	Microprocessor error
FAN	Blower pressure failure
FFL	Flame sensing when pilot and gas valves are closed
GVC	Gas valve closed
GVO	Gas valve open
HL1	High limit switch #1 open
HL2	High limit switch #2 open
IGN	Ignition failure
ILO	Ignition lockout - Propane units only
PRS	Water pressure switch open
ROL	Heat roll-out safety switch open
SNS	Sensor failure, Water temp. below 36°F or above 110°F
VNT	Vent switch open - This is jumped from the factory.

REMOTE CONTROL INSTALLATION AND OPERATION

CAUTION: Before installing remote controls to the digital thermostat model heaters, read the following:

The digital thermostat model is remote-ready in most cases. The digital liquid crystal display (LCD) shows the actual pool temperature, operating status, and service codes (See examples below). The touch pad on the control panel allows you to select the desired pool or spa temperature. It also indicates when a remote system is controlling the heater by displaying REM in the display. When connecting the heater to a remote system, identify whether it is a two- or three-wire remote system. Select the appropriate instruction listed below to properly install the remote to the heater.

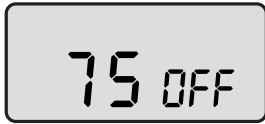

OFF Mode



Heating in the POOL Mode

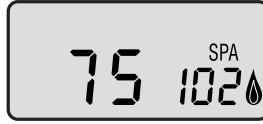

Heating in the SPA Mode



Remote Mode



7-PIN Remote Interface Harness

ACTIVATING THE REMOTE

The digital thermostat heaters have the ability to disconnect from the remote it is wired to. To activate or deactivate the remote follow these steps:

Press and hold all three buttons for 5 to 7 seconds.

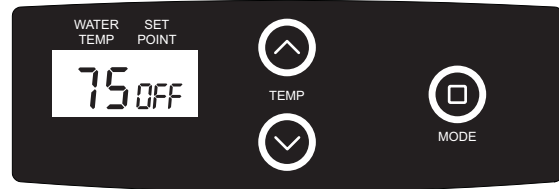

The digital display format will change and indicate **REMOFF** or **REMOOn**.

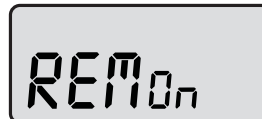

REMOOn = External remote control active (display will flash REM)

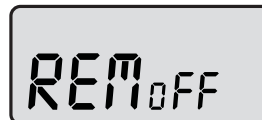

REMOFF = Remote disabled (heater thermostat will control heater - use this mode to test heater operation)

REMOTE OPERATION

The digital model heaters are equipped with the ability to work with external remote controls. The supplied 7-pin remote wiring connector supplies power out to either a toggle switch or the switch contacts of a third party remote. The remote works by either making or breaking the circuit created by the remote wiring. Typically, a remote does not supply power to the heater, it only provides a switching function to turn the heater On or Off. **If your remote is supplying its own voltage to the heater, it will not work with this heater and may damage the digital circuit board.**

For operation of the heater using the onboard thermostat controls with a time clock, see the "Time Clock / Fireman's Switch" section.

NOTE: When in remote operation, the keypad mode and temp buttons are disabled. Remote will flash even when the unit is off.



Note: Electrostatic Discharge (ESD) damage can be caused by direct or indirect contact with the wiring or circuit board. When one walks to the heater area, an electrostatic charge accumulates on the body. Contact of a finger allows the body to discharge, possibly causing device damage. This damage can be limited if the service person discharges himself, following ESD preventive/removal practices, and holds on to the heater enclosure for 5 seconds before proceeding.

THERMOSTAT OPERATION - ADVANCED FLAME TECHNOLOGY (AFT) BOARD

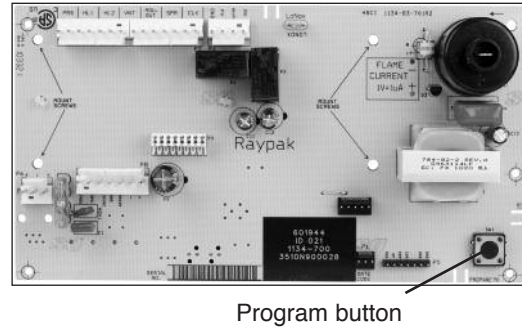
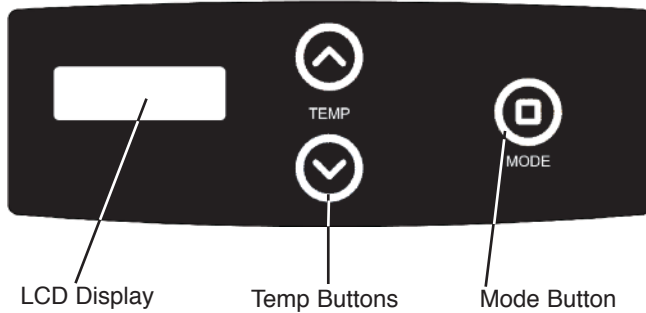

The pool heater touchpad, located on the upper front panel of the heater, allows the user to select either POOL or SPA operation, and to adjust the setpoint temperature. The LCD display window indicates the mode (OFF, SPA, POOL) and the actual water temperature. A manual power switch provided below the touchpad turns the control power ON or OFF.

Mode Button

The MODE button is used to select either POOL or SPA operation. It also allows the user to turn the heater off electronically, allowing the LCD display to remain energized and to continue showing the actual water temperature.

Temp Buttons

If the heater is in POOL or SPA mode, the desired water temperature (SETPOINT) will also be displayed and may be adjusted using the UP or DOWN buttons.

Operation

In the POOL or SPA modes, the actual water temperature is displayed along with the desired water temperature (SETPOINT). When the water temperature is above the setpoint, "Water Temp" will alternate with "No Demand." When the water temperature is below the setpoint and the heater is firing, "Water Temp" will alternate with "Heating."

To adjust the setpoint temperature, make sure the control is in the appropriate mode (POOL or SPA) and push the UP or DOWN buttons.

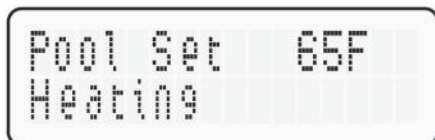
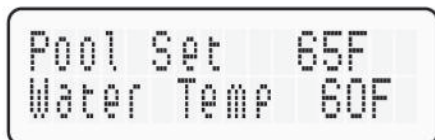

ALTERNATING DISPLAYS DURING HEATING

Service Menu and Fault History

To access the Service Menu and fault history, press the MODE and UP arrow buttons simultaneously for 3 to 5 seconds. The heater will continue to operate normally while in the Service Menu. The first screen displayed is the Flame Strength indicator, which indicates the pilot flame current using a bar graph and numerical display. A signal of less than 4 indicates a weak flame signal and may require service. Refer to Section 5 – Troubleshooting for possible causes and corrections.



FLAME STRENGTH INDICATOR

Press the DOWN arrow button. The Supply Voltage screen indicates the voltage supplied to the control board. Normal readings range from 24 to 29 volts.

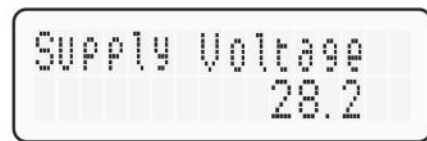

SUPPLY VOLTAGE INDICATOR

Press the DOWN arrow button. The Run Time indicates the total hours of operation for the pool heater, as measured by the amount of time that the main gas valve has been powered. The Cycle count indicates the number of on/off cycles of the heater, as measured by the number of times the pilot valve has been powered.

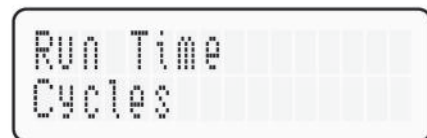

RUN TIME INDICATOR

Press the DOWN arrow button. The Fault History can display up to ten faults in memory. The order of the faults begins with "Fault Last," which is the most recent fault, and then proceeds to the second through tenth most recent messages in chronological order. The second line of the display shows the fault message. If there are no faults in the history buffer, the second line reads "All Faults Clear."

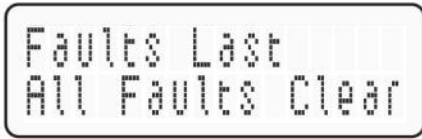

FAULT HISTORY

Program Button

- 1) To access the program screen, press the Mode button until the display reads **OFF**. Remove the four screws holding the control cover on. Swing control panel down so the back side of the board is visible (see page 31). Locate the Program Mode button as shown in the figure on page 37. Press the program button (5-7 seconds) until **Set Factory Defaults** appears on the digital display. Release the program button.
- 2) Press the **Mode** button sequentially until the desired program event is reached. There are 5 different events that can be programmed. They appear in the sequence listed below:

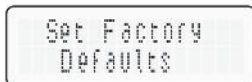

Resets board to factory default settings.

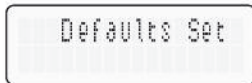

Resets faults in the History File.

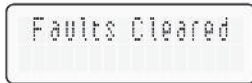

Change from Fahrenheit to Celsius.



SPA setpoint maximum adjustment.



POOL setpoint maximum adjustment.

Set Factory Defaults

Refer to step one above to access the program screen. **Set Factory Defaults** should appear on the screen. If it does not, press the **Mode** button until **Set Factory Defaults** appears on the digital display. Press and hold both UP and DOWN buttons for 5-7 seconds until **Defaults Set** appears. This operation resets the operating program to its factory default values. Both the POOL and SPA setpoints will revert to 65°F (18.5°C) and both POOL and SPA maximum temperature settings will be 104°F (40.0°C).

Clear Faults

Refer to step one above to access the program screen. Press the **Mode** button until **Clear Faults** appears on the digital display. Press and hold both UP and DOWN buttons for 5-7 seconds until **Faults Cleared** appears. This operation resets the Fault History file to "0" and clears all the stored faults.

Fahrenheit or Celsius

Refer to step one above to access the program screen. Press the **Mode** button until **Fahrenheit** or **Celsius** appears on the digital display. The digital display is capable of displaying Celsius as well as Fahrenheit temperatures. The UP or DOWN buttons will select **Fahrenheit** or **Celsius** on the temperature display. Choose the desired temperature scale.

Spa Max Temp – Spa Set Point Maximum Adjustment

Refer to step one above to access the program screen. Press the **Mode** button until **Spa Max Temp** appears on the digital display. Using the UP and DOWN buttons will change the Maximum Temperature Setting to your desired value. The control can be set for a maximum of 107°F.

Pool Max Temp – Pool Set Point Maximum Adjustment

Refer to step one above access into the program screen. Press the **Mode** button until **Pool Max Temp** appears on the digital display. Using the UP and DOWN buttons will change the Maximum Temperature Setting to your desired value. The control can be set for a maximum of 107°F.

NOTE: The LCD temperature display may not agree with the temperature reading of your pool or spa thermometer. The heater reads the water temperature at the inlet. Due to the circulation characteristics of any pool or spa, the water temperature at the inlet to the heater may differ from that observed at a given location in the pool or spa.

STATUS AND DIAGNOSTICS

The digital thermostat models are programmed to display a variety of status and diagnostic messages, depending on the operating conditions.

The following heat status messages are displayed in Pool, Spa, and Remote modes when there are no active fault conditions.

Display	Condition
Heating	Call for heat established, flame present
Spark	Spark operating
No Demand	Heat demand is satisfied

The following conditions are displayed in Pool, Spa and Remote modes.

Display	Condition
Sensor Failure	Thermistor temperatures disagree by more than 2°F
Sensor Open	Thermistor sensor failed open. (Below -20°F)
Sensor Short	Thermistor sensor failed short. (Above 217°F)
Flame w/o CFH	Board is sensing flame when both main and pilot valves are commanded shut.
PV Output Fault	Pilot gas valve output is not in commanded state.
MV Output Fault	Main gas valve output is not in commanded state.
LoNox Tab Fault	Voltage is sensed at the Lo NOx terminal on a non-Lo NOx heater (Lo NOx tab is intact).
Internal Fault	Board fault, replace board.
EEPROM Fault	Memory fault, reset set points, replace board if fault does not clear.
Clock/Fireman Sw	Time clock/fireman switch circuit is open.
Low Temp Lockout	Water temperature below 36°F.

The following conditions are displayed only while there is a demand for heat present.

Display	Condition
Water Sw Open	Water pressure switch open.
Vent/Field Sw #1	Vent spill switch/field switch #1 open.
Hi Limit 1 Fault	High limit 1 open.
Hi Limit 2 Fault	High limit 2 open.
Rollout Sw Open	Rollout switch open.
Flow/Field SW #2	Flow switch/field switch #2 open.
Fan Lockout	3 fan switch faults within same heat demand cycle, power must be cycled to clear the fault.
Fan 5 Min Delay	Heater shut down for 5 minutes because LoNox fan switch didn't close.
Ignition Lockout (Propane Tab Broken)	Alternating with "No pilot sensed" - Pilot flame not established within the required time (15 sec or 90 sec). Alternating with "Main Ign Failure" - Pilot flame lost during the 8 second trial to ignite the main burner.
Ignition Failure (Propane Tab Not Broken)	Alternating with "No pilot sensed" - Pilot flame not established within 90 seconds.
Ign 6min Delay (Propane Tab Not Broken)	Alternating with "Main Ign Failure" - Pilot flame lost 4 times within the 8 second trial to ignite the main burner. Heater will lockout for 6 minutes before retrying.

REMOTE CONTROL INSTALLATION AND OPERATION

CAUTION: Before installing remote controls to the AFT thermostat model heaters, read the following:

The digital thermostat model is remote-ready in most cases. The digital liquid crystal display (LCD) shows the actual pool temperature, operating status, and service codes (See examples below). The touch pad on the control panel allows you to select the desired pool or spa temperature. It also indicates when a remote system is controlling the heater by displaying **Remote** in the display. When connecting the heater to a remote system, identify whether it is a two- or three-wire remote system. Select the appropriate instruction listed below to properly install the remote to the heater.

Off
Water Temp 69F

OFF Mode

Pool Set 65F
Water Temp 60F

Heating in the POOL Mode

Spa Set 65F
Water Temp 60F

Heating in the SPA Mode

Remote
Water Temp 69F

Remote Mode

Off
No Demand

Pool Set 65F
Heating

Spa Set 65F
Heating

Remote
No Demand

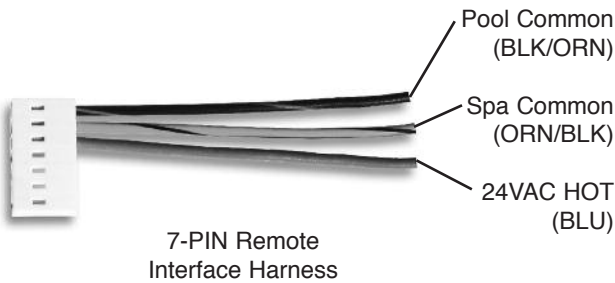

ACTIVATING THE REMOTE

To activate or deactivate the remote function, follow these steps:

Press and hold the UP and DOWN arrow buttons for 3 to 5 seconds.

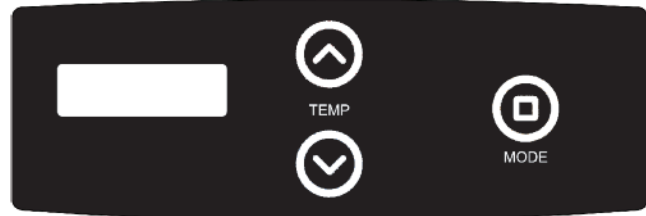

The second line of the display will alternate even when the unit is off (“No Demand”).

Remote Pool 65F
Water Temp 60F

Remote Spa 65F
Water Temp 60F

Remote Pool 65F
Heating

Remote Spa 65F
Heating

REMOTE OPERATION

The AFT model heaters are equipped with the ability to work with external remote controls. The supplied 7-pin remote wiring connector supplies power out to either a toggle switch or the switch contacts of a third party remote. The remote works by either making or breaking the circuit created by the remote wiring. Typically, a remote does not supply power to the heater, it only provides a switching function to turn the heater On or Off. **If your remote is supplying its own voltage to the heater, it will not work with this heater and may damage the digital circuit board.**

For operation of the heater using the onboard thermostat controls with a time clock, see the “Time Clock / Fireman’s Switch” section.

NOTE: When in remote operation, the keypad mode and temp buttons are disabled.



Note: Electrostatic Discharge (ESD) damage can be caused by direct or indirect contact with the wiring or circuit board. When one walks to the heater area, an electrostatic charge accumulates on the body. Contact of a finger allows the body to discharge, possibly causing device damage. This damage can be limited if the service person discharges himself, following ESD preventive/removal practices, and holds on to the heater enclosure for 5 seconds before proceeding.

REMOTE CONTROL WIRING

Important Installation Notes for Remote or External Wiring Configuration

- Remote wiring must be run in a separate conduit.
- Remote wiring must not be run parallel to high voltage lines.
- For runs of under 30 feet, remote wiring should have stranded conductors with a minimum of 22 AWG, 600V, cable twisting 1.5 to 2.5 in. lay and jacketed.
- For runs over 30 feet, the conductors should be a minimum of 20 AWG, 600V, cable twisting 1.5 to 2.5 inch lay that is shielded and jacketed.
- Maximum cable length is 200 feet.
- For both two- and three-wire remote systems, the provided 7-pin wiring connector must be utilized. Please refer to the wiring instructions.

NOTE: The remote wires must be connected to the 7-pin connector **before** the connector is plugged into the board.

2-Wire Remote Control (On-Off)

This application assumes that only one heating function (pool or spa) is required.

1. Turn on power to the heater.
2. For a 2-Wire Remote Control from a remote without its own sensor, push the mode button to the "POOL" or "SPA" mode and set the desired setpoint (eg. 102 °F for Spa).
3. For a 2-Wire Remote Control from a remote with its own sensor, push the mode button "POOL" or "SPA" mode and set the temperature to the highest setting available on the control. The actual setpoint will be controlled by the remote control.
4. Turn the mode button to "OFF" and remove power from the heater.
5. On the "Remote Interface Harness", connect the BLUE wire to one side of the "REMOTE" switch and connect the other side to either the ORANGE/BLACK wire for "SPA" operation or the BLACK/ORANGE wire for "POOL" operation.
6. Attach wire nut on unused wire to the "Remote Interface Harness."
7. Install the "7-Pin Remote Interface Harness" to the P8 connector and turn power "On" to the heater.

To activate the remote control, see page 36 for the Digital PC Board and page 40 for the AFT Board.

3-Wire Remote Control Using Three-Position Switch (Pool-Off-Spa, or Low-Off-High)

This application assumes that both heating functions (pool and spa) are required.

1. Turn on power to the heater.
2. Push the mode button to the "POOL" or "SPA" mode and set the desired temperature for each (eg. 80°F for Pool and 102°F for Spa).
3. Turn the mode button to "OFF" and remove power from the heater.
4. On the "Remote Interface Harness" connect the BLUE wire to one side of the "REMOTE" switch and connect the ORANGE/BLACK wire for "SPA" operation and the BLACK/ORANGE wire for the "POOL" operation.
5. Install the "Remote Interface Harness" to the P8 connector and turn power "ON" to the heater.

To activate the remote control, see page 36 for the Digital PC Board and page 40 for the AFT board.

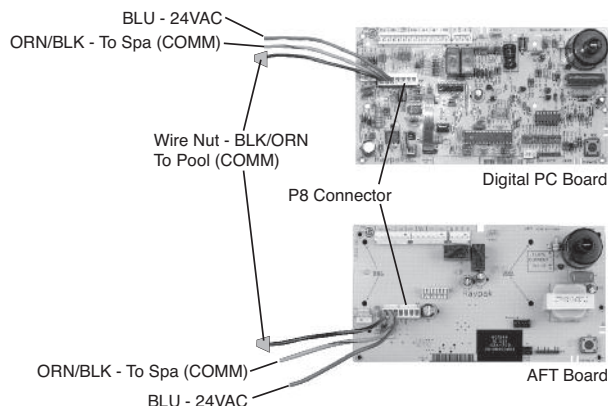

2-Wire Remote Control

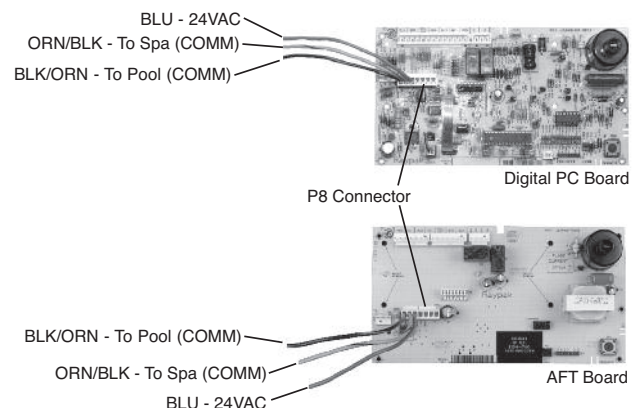

3-Wire Remote Control

TIME CLOCK/FIREMAN'S SWITCH

To operate the heater with a time clock, connect the timer to the fireman's switch connection in the heater's wiring. The time clock should be of the dual switch type and set to shut off the call for heat to the pool heater 15 to 20 minutes prior to shutting down the pool pump. On millivolt heaters the fireman's switch connection is a wire nut located in the Violet/Black wiring between the manual toggle switch and the gas valve. For digital heaters the fireman's switch connection is located on the 14-pin header connected to the digital control board. Splice into the red wire jumper tagged "Where necessary add "Fireman's" switch circuit here" to connect the time clock. **The fireman's switch connection on both millivolt and digital heaters must be a dry contact and must not supply power to the heater. Powering the fireman's switch connection externally may damage the heater, and is not covered by warranty.**

Millivolt heaters: Do not exceed 15ft of total wiring using 14 AWG stranded copper wire rated for 105°C (221°F) minimum.

Digital/AFT heaters: Do not exceed 50ft of total wiring using 18 AWG stranded copper wire rated for 105°C (221°F) minimum.

NOTE: When using a time clock, the heater will display "CLK" (with a Digital PC Board) or "Clock/Fireman Sw" (with an AFT Board) when the fireman's switch is open, indicating that the time clock has shut off the call for heat.

WATER PRESSURE SWITCH

The water pressure switch, or heater actuator, ensures that the heater operates only when the filter pump is in operation. It is located on the inlet/outlet header. It is factory set at 1.75 PSI for deck-level installations. When the heater is located below the level of the spa or pool, it may be necessary to adjust the pressure switch to compensate for the no-flow static head. If it is necessary to adjust the water pressure switch, utilize the following procedure:

WATER PRESSURE SWITCH ADJUSTMENT



Adjustment Knob

1. Make sure the pool filter is clean before adjusting the switch.
2. Set the heater control to the OFF mode.
3. Turn the filter pump on and confirm that the pressure

switch is closed (use a multimeter to check). If the pressure switch fails to close, either the switch setting is too high or not enough pressure is being supplied by the filter pump.

4. Turn the heater ON.
5. Manually turn the pressure adjustment knob clockwise until the heater shuts off. (A flat screwdriver may be necessary if knob is too tight.)
6. Slowly turn the adjustment knob counter-clockwise until the heater calls for heat again.
7. Turn an additional 1/2 turn counter-clockwise.
8. While the heater is running, check the adjustment by turning the pump off and on several times. The burners should shut off immediately when the pump is turned off. If it does not, repeat the above steps until proper operation is observed.

PRESSURE SWITCH ADJUSTMENT RANGE

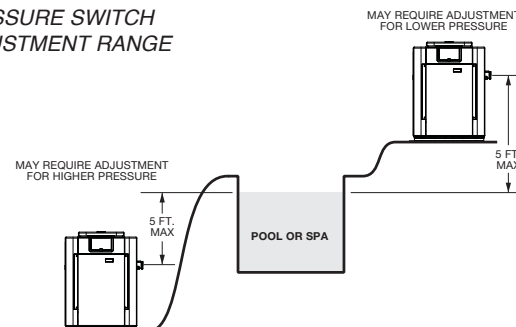

NOTE: If heater is installed outside of the limits shown, a higher pressure rated (11 psi) switch may be used. A flow switch, mounted and wired adjacent to the heater, may be used in place of the factory-mounted pressure switch. See Parts List (pg. 56) for 11 psi water pressure switch.

TWO-SPEED PUMPS

In some cases, the flow on the low-speed is insufficient to operate the heater. This is apparent when the water pressure switch cannot be further adjusted or if the heater makes banging noises or shuts off on high limit. In these cases, the pump must be run at high speed when heating the water.

CAUTION: Do not operate the heater without the function of a properly adjusted water pressure switch or flow switch.

FLAME ROLL-OUT SAFETY SWITCH



Atmospheric heaters are equipped with a thermal cutoff device to prevent flame roll-out in the event the heat exchanger becomes blocked. This is a "single-use" type fusible link or thermal fuse, that must be replaced when disabled by an over-temperature condition, caused by excessive restriction in the heat exchanger flue passage.

HIGH LIMITS

The heater is equipped with two automatic high limits. Both are located in the inlet/outlet header. Both are set to open at 135°F.

NOTE: An erratic high limit is often characteristic of an internal heat exchanger problem, e.g. scale build-up, defective bypass. Refer to Troubleshooting section (on pg. 47).

HIGH LIMIT REMOVAL

1. Shut off main electrical power switch to heater.
2. Remove inlet/outlet inspection panel.
3. Remove defective high limit and replace with a new high limit.
4. Replace inspection panel.



PILOT SAFETY - Millivolt Models

Heaters equipped with the standing pilot (millivolt system) have pilot generators which act as a safety device to shut off the flow of gas to the main burners and the pilot burner in case the pilot flame is extinguished. The pilot burner must be manually re-lighted to place the heater in operation again. Refer to the lighting instructions provided on the heater label.

PILOT SAFETY - Digital/AFT Models

The heater employs a pilot safety which closes the main gas valve within 8/10ths of a second whenever the pilot flame is interrupted. The pilot flame is automatically lit when the device is powered. The heater performs its own safety check and opens the main valve only after the pilot is proven to be lit.

BURNER TRAY REMOVAL - ATMOSPHERIC MODELS

1. Shut off main electrical power switch to heater.
2. Shut off gas upstream of heater.
3. Remove front door.
4. Disconnect gas line from gas valve.
5. Remove (2) screws that mount burner tray to unit, and (2) screws that secure gas valve to jacket.
6. Disconnect wires that terminate at gas valve.
7. Disconnect hi-tension wire from PC board.
8. Slide out burner tray.
9. Reverse above procedure to reinstall.

GAS VALVE REMOVAL - ATMOSPHERIC MODELS

1. Shut off gas supply to the heater. Remove gas piping to gas valve inlet.
2. Disconnect wires, pilot tubing and bleed line, if required.
3. Remove burner tray from heater.
4. Turn vertical gas pipe from manifold slightly and unscrew gas valve.
5. Reverse above procedure to reinstall.

MAIN BURNER AND ORIFICE REMOVAL - ATMOSPHERIC MODELS

1. Remove burner tray.
2. Remove screws and burner hold-down bracket.

NOTE: If the heat exchanger is sooted badly, the burner hold-down bracket and spacer can become distorted from direct-flame impingement and this usually necessitates replacement of these parts.

3. Lift burners from slotted spacers and slide from orifices. Clean with a wire brush.
4. Orifices usually do not need to be replaced. To clean, run either copper wire or wood toothpick through orifice. **Do not enlarge hole.** To remove orifice, use a socket wrench and remove from manifold. **DO NOT** overtighten when reinstalling.

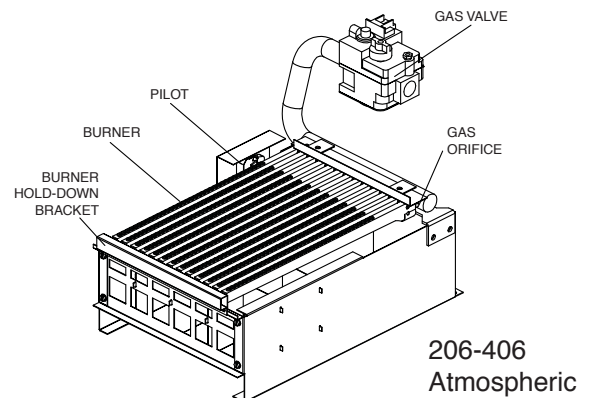

PILOT REMOVAL AND CLEANING

1. Disconnect pilot tubing and wires from gas valve.
2. Remove pilot assembly from burner tray.
3. Remove pilot from bracket.
4. Remove pilot orifice and air opening (Honeywell MV unit only), and clean with wire or small brush.

CAUTION! Do not enlarge hole in pilot orifice.

5. Reverse above procedure to reinstall.

HONEYWELL MILLIVOLT

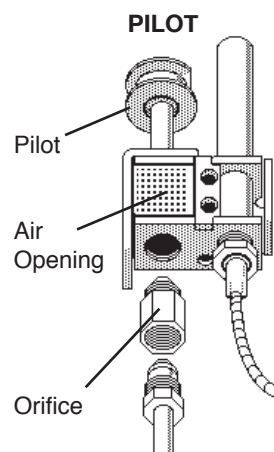

ROBERTSHAW MILLIVOLT

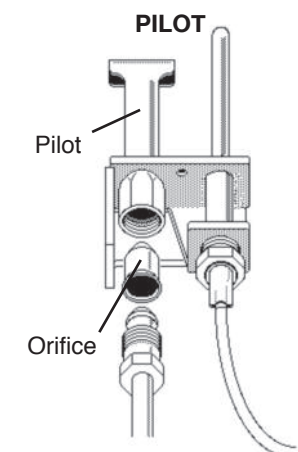

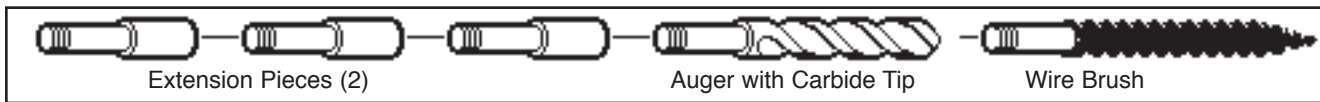

HEAT EXCHANGER REMOVAL

1. Shut water, gas and electricity off, close valves and relieve pressure, then remove relief valve. Remove side inspection panels.
2. Remove top jacket holding screws.
3. Remove rear top panel.
4. Remove screws mounting the rain shield to the rear panel. Also remove the screws that mount the rain shield to the sway brace. Remove rain shield.
5. Remove the four (4) screws holding down the flue collector. Remove the flue collector.
6. Disconnect flange nuts on Inlet/Outlet header, loosen union(s) at gas pipe and slide heater away from piping.
7. Lift heat exchanger straight up using caution not to damage refractory.
8. Reverse above procedure to reinstall. Make sure the insulation strips are properly replaced on top of the refractory retainer.

4. Remove heat exchanger from the heater and wash with a garden hose, making sure soot is removed from spaces between fins.
5. Reverse above procedure to reinstall.

NOTE: *In extreme cases it may be necessary to do steam cleaning at the local car wash. **DO NOT WIRE BRUSH.***

TUBE CLEANING PROCEDURE

Establish a regular inspection schedule, the frequency depending on the local water conditions and the severity of service. Do not let the tubes clog up solidly. Clean out deposits over 1/16" in thickness.

The heater may be cleaned from the return header side, without breaking pipe connections. It is preferable, however, to remove both headers for better visibility through the tubes and to be sure the ground-up lime dust does not get into the system.

Note that you do not remove the top panel or the heater exchanger, generally.

After reaming, mount the wire brush in place of the auger and clean out debris remaining in the tubes.

Another method is to remove the heat exchanger, ream tubes and immerse heat exchanger in non-inhibited de-scale solvent for severe scale build-up.

DESOOTING PROCEDURE

WARNING: SOOT IS COMBUSTIBLE. EXERCISE EXTREME CARE.

Soot will clog areas between fins and cause eventual tube failure. Any sign of soot at the base of the burners or around the outer jacket indicates a need for cleaning.

1. Remove top and flue collector from cabinet.
2. Remove "V" baffles from heat exchanger.
3. Remove burner tray. (See page 43).

COMBUSTION CHAMBER REMOVAL

To remove combustion chamber, you must first have removed the heat exchanger.

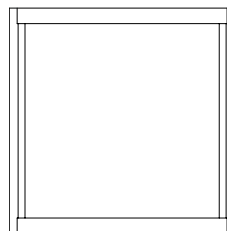

Atmospheric Heaters

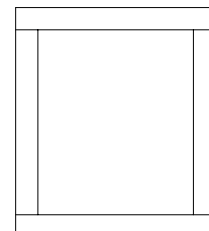

Lo NOx Heaters

REFRACTORY PANELS - TOP VIEW

IMMERSION WELL REPLACEMENT

(Millivolt and ASME)

1. Shut off water to heater and drain heat exchanger.
2. Remove access panel on water connection side.
3. Remove old immersion well with bushing and sleeve.
4. Install replacement well in header.

NOTE: *Installation in polymer header should be hand tight plus 1/2 turn.*

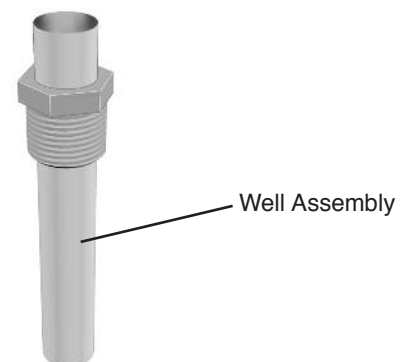

UNITHERM GOVERNOR (U.G.) REPLACEMENT

1. Shut water, gas and electricity off, close valves and relieve pressure.
2. Drain heat exchanger.
3. Remove retainer plug located next to the outlet pipe connection.
4. Unsnap old U.G. to remove from retainer plug. Snap in new U.G.
5. Reinstall retainer plug, taking care to lubricate gasket with a non-petroleum based grease such as AquaLube.

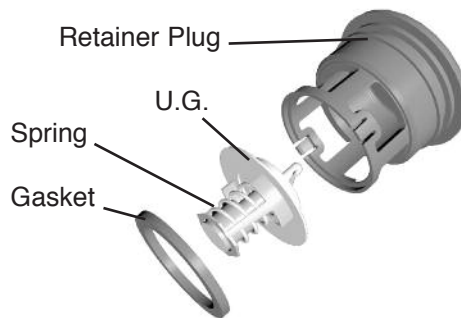

To test the operation of the Unitherm Governor, place in hot water (over 110°F) and watch for movement against spring. If there is no movement, replace unit.

LO NO_x POOL HEATERS

The Lo NO_x pool heaters are certified and tested under the ANSI Z21.56/CSA 4.7 Standard for Gas-Fired Pool Heaters.

The heater should be installed to meet all local codes, and the latest editions of the National Fuel Gas Code Z223.1 and the National Electrical Code, ANSI/NFPA 70.

OPERATION

On call for heat, the ignition system, consisting of an electronic spark module, gas valve and pilot system, is energized. Providing the pilot is proven, the blower will start running, the main gas valve will open and the heater will operate. When the operating control is satisfied the heater will shut down.

START-UP PROCEDURES

1. Turn on power to the heater with gas supply off.
2. Turn on gas supply.
3. Set controller to call for heat.
4. System should start as follows:
 - a. Spark will turn on, pilot gas valve will open, and the blower will begin running.
 - b. Once the blower provides pressure, the main gas valve will open.
 - c. Heater will operate until call for heat is satisfied.

NOTE: *Door must be in place for proper operation.*

BLOWER ADJUSTMENT

This Lo NO_x pool heater is equipped with a combustion air plate (baffle) mounted on the air intake to the combustion air blower. The baffle has a hole that is utilized to control the air inlet to the blower.

When the combustion air setting is proper, there will be some lifting of the flames on some areas of the burner

deck under cold-start conditions. After about five minutes of operation, the flames should settle down and blue tips should become visible. Lifting of flames beyond five minutes would indicate too much combustion air.

VISUAL INSPECTION

Flames can be observed through the opening below the plenum. Flame color is blue and evenly spread on the top surface of the burner. At least every three months a visual inspection should be made of the burners.

ELECTRICAL

Be sure that electrical service to the heater has proper overload fuse or circuit breaker protection, wire size and connections which comply with all applicable codes.

FLAME ROLL-OUT SAFETY SWITCH

Lo NO_x heaters are equipped with a thermal cut-off device to prevent flame roll-out in the event the heat exchanger becomes blocked. It is a "manual reset" type roll-out switch that must be reset by a service technician after any over-temperature conditions have been fixed. Excessive restriction in the heat exchanger flue passage may cause the switch to disable the heater.

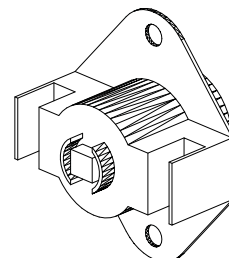

Manual Reset Switch

LO NO_x HEATERS (CONTINUED)

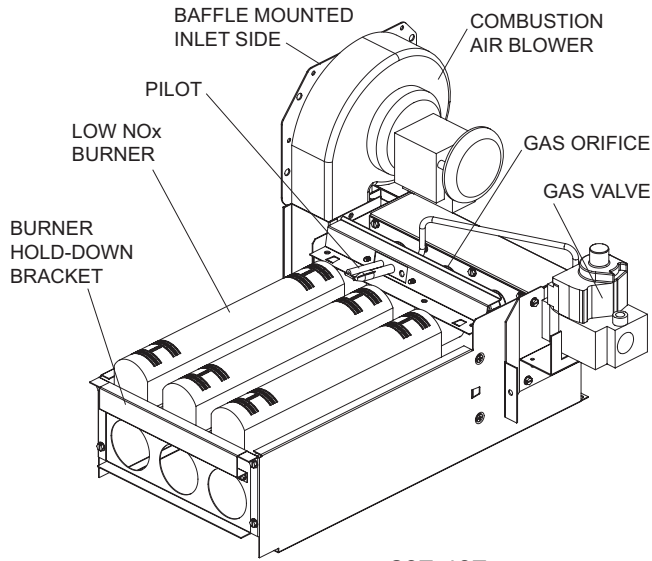

207-407
Lo NO_x Burner Tray

BURNER TRAY REMOVAL

1. Shut off main electrical power switch to heater.
2. Shut off gas upstream of heater.
3. Remove front door.
4. Disconnect gas line from gas valve.
5. Remove (2) screws that mount burner tray to the base of the unit, and (2) screws that mount the blower box to the burner tray, and (1) screw that secures the anti-rotation bracket to the heater.
6. Disconnect wires that terminate at gas valve.
7. Unscrew (4) screws that secure the control box.
8. Disconnect pilot wire from the pilot assembly.
9. Disconnect wire connector from the combustion blower.
10. Carefully slide out the burner tray assembly.
11. Reverse above procedure to reinstall.

GAS VALVE REMOVAL

1. Remove burner tray, following above procedure.
2. Disconnect, pilot tubing from gas valve.
3. Remove (2) screws that mount anti-rotation bracket to the burner tray.
4. Turn vertical gas pipe from manifold slightly and unscrew gas valve.
5. Reverse above procedure to reinstall.

MAIN BURNER AND ORIFICE REMOVAL

1. Remove burner tray, following above procedure.
2. Remove pilot. See pilot removal procedure.
3. Remove (8) total screws from the burner hold-down brackets, front and rear of tray.
4. Remove (8) total screws from the left and right sides of the manifold assembly. Detach the air/gas manifold assembly from the burner tray assembly.
5. Remove burners by raising them straight up off the rear end slots.
6. Use a long 9/16" socket wrench to remove orifice from the gas manifold.
7. Reverse above procedure to reinstall.

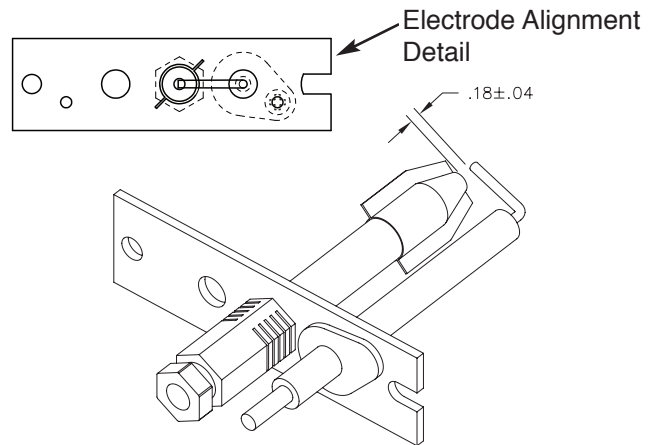

Lo NO_x Horizontal Pilot

PILOT REMOVAL

1. Disconnect pilot tubing from gas valve.
2. Remove the pilot wire from the pilot assembly.
3. Remove (2) screws that mount the pilot assembly to the burner tray.
4. Pull the pilot assembly downwards and outwards.
5. Reverse above procedure to reinstall.

COMBUSTION BLOWER REMOVAL

1. Remove the (2) screws that secure the blower box to the burner tray.
2. Remove (2) screws that mount the blower box to the base of the heater.
3. Disconnect wire connector from the combustion blower.
4. Carefully remove blower box with combustion blower.
5. Remove (2) screws that secure combustion blower to blower box.
6. Reverse above procedure to reinstall.

SECTION 5 - TROUBLESHOOTING

MECHANICAL

IMPORTANT NOTICE These instructions are intended for the use of qualified personnel who are specifically trained and experienced in the installation of this type of heating equipment and related system components. Installation and service personnel may be required by some states to be licensed. Persons not qualified shall not attempt to install this equipment nor attempt repairs according to these instructions.

PROBLEM	CAUSE	SOLUTION
Harmonics, or whining noise	U.G. inoperative.....	Check movement by putting in hot water (110°F or higher). If no movement, replace.
	*Debris or restriction in system.....	Locate the restriction and remove. Flush system and clean.
	*Debris in gas line.....	Remove debris or blow out gas line.
	Low flow.....	Scale forming in heat exchanger - clean heat exchanger and check pool pH and total alkalinity.
Heater going on and off continuously	Dirty filter.....	Clean or replace filter.
	Low water level in pool.....	Raise water level.
	External bypass setting out of adjustment.....	Adjust bypass.
	*Pressure switch out of adjustment.....	Adjust pressure switch.
Liming or scale forming in exchanger	Pool water.....	See Water Chemistry on page 2.
	Bypassing too much water.....	Inspect bypass for movement, if no movement, replace.
	U.G. not functioning.....	Replace if no movement when heated.
Sooting	High flow rates.....	Reduce by adding manual bypass valve. Adjust manual bypass valve until heater outlet water temperature is between 105°F and 110°F.
	U.G. Inoperative.....	Check movement by putting in hot water (110°F or higher). If no movement, replace.
	*Air starvation.....	Refer to installation instructions.
	*Improper venting.....	Follow recommended installation instructions.
	*Insects or debris clogging burner intake ports.....	Clean burners.
Pilot outage or "Weak Flame" signal	Low gas pressure.....	Adjust gas pressure.
	Restricted/dirty pilot.....	Clean pilot and/or electrode.
	Weak pilot generator.....	Replace pilot.
Yellow lazy flame	Low gas pressure.....	Adjust gas pressure.
	*Insects or debris clogging burner intake ports.....	Clean burners.
Outer jacket very hot (paint blistered)	*Broken refractory caused by shipping damage or improper combustion..... Excessive sooting of heat exchanger..	Replace refractory panels. Determine cause of sooting & correct.
Takes too long to heat pool or spa	Under-sized heater.....	Calculate heating capacity of heater: $\frac{\text{Htr. output(BTUH)}}{\text{Pool gallonage} \times 8.33}$ or refer to heater sizing chart. This does not take into account heat loss due to weather.
	Filter not running long enough.....	Reset time clock.
	Dirty filter.....	Clean filter.
	Gas line or meter undersized.....	Refer to installation instructions.
Leaking at well	Overacid.....	Replace well and maintain proper water chemistry.
Leaking at heat exchanger	Overacid.....	Replace heat exchanger and maintain proper water chemistry.
Gasket brittle and leaking - (overheated)	Heater running after pump shuts off....	See Pressure Switch Adjustment.
	Refractory damage.....	Replace refractory.
	Sooted heater.....	Determine cause of sooting and correct.
Combustion fan not running "Fan 5 min Delay" signal or "Fan Lockout" signal	Fan relay.....	Replace fan relay.
	Fan.....	Loose connection or failed motor.
	Burned motor	Incorrect wiring, replace blower.
	Air pressure switch.....	Replace air switch.

* Indicates symptom which usually occurs on initial start-up.

ELECTRICAL - STANDING PILOT MILLIVOLT

POOL OR SPA HEATER ELECTRICAL CHECK WITH MILLIVOLT GAS VALVE

CAUTION: For qualified service personnel only.

1. Filter must be on with adequate water flow through heater.
2. Gas valve must be in "ON" position. Thermostat set higher than pool water temperature.
3. Jumpers are for temporary check only. If left in place, they could cause the heater to burn up.

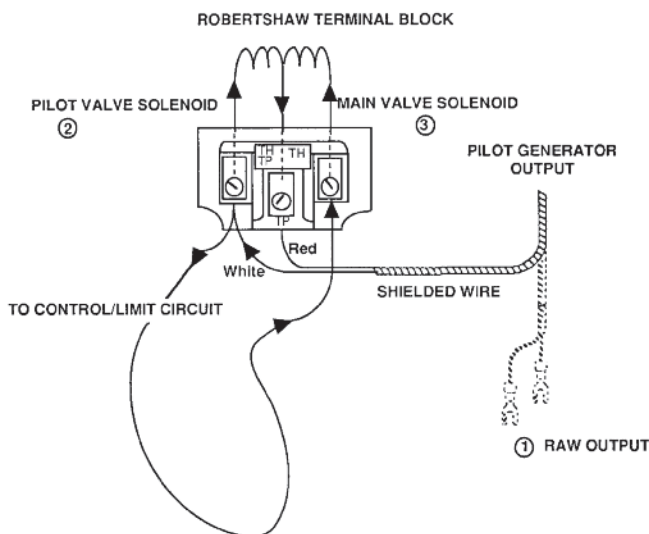
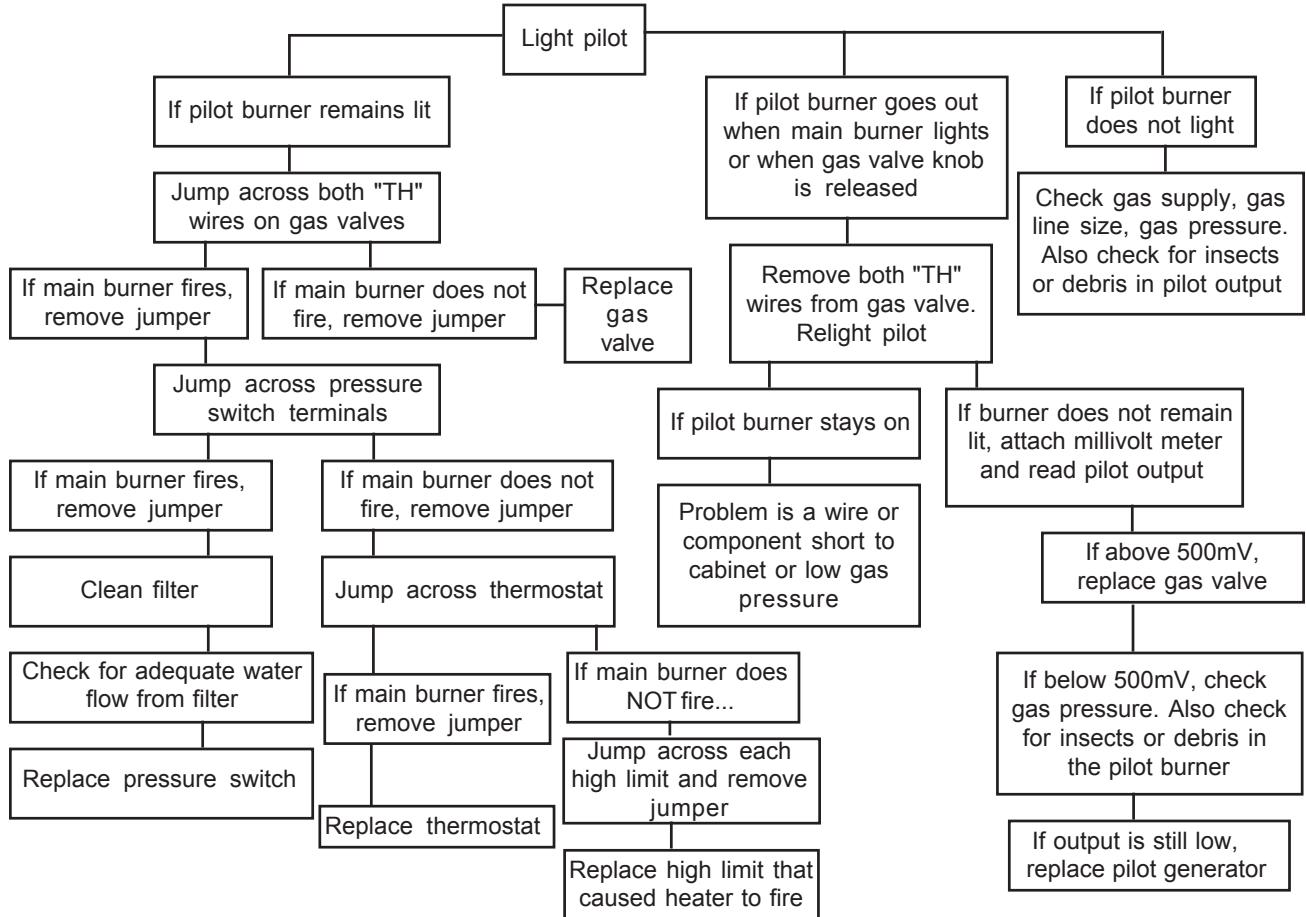

- 1 Raw Output ($700\text{mV} \pm 100$)
Pilot generator disconnected from valve (knob must be held down to keep pilot on).
White – Negative
Red + Positive
- 2 Pilot Load ($500\text{mV} \pm 100$)
Pilot generator connected to valve-Power applied to pilot solenoid.
TP(Thermopile-Robertshaw)
PP(Power Pile-Honeywell)
TH TP – Common
TH PP – Common
- 3 Main Valve Load ($200\text{mV} \pm 100$)
Control/Limit circuit closed (All switches "ON")
TP(Thermopile-Robertshaw)
PP(Power Pile-Honeywell)
TH TP – Common
TH PP – Common

ELECTRICAL - ELECTRONIC IGNITION IID

WARNING HIGH VOLTAGE
For qualified technicians ONLY

NOTE: Some heaters may be equipped with an ignition module that shuts off pilot gas if pilot fails to light. To reset, interrupt power to heater.

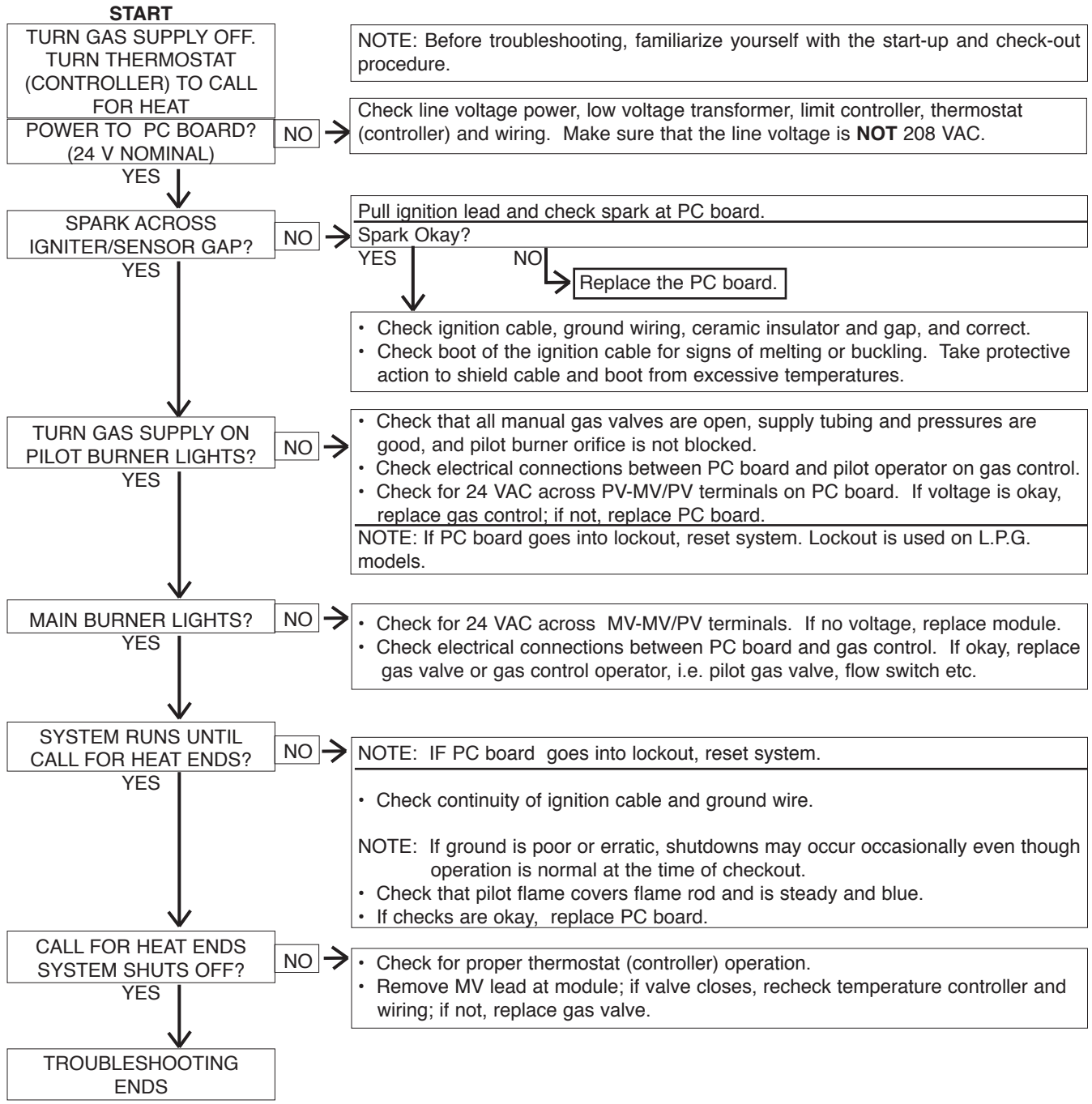

DIGITAL/AFT CONTROL LOGIC - FLOW CHART

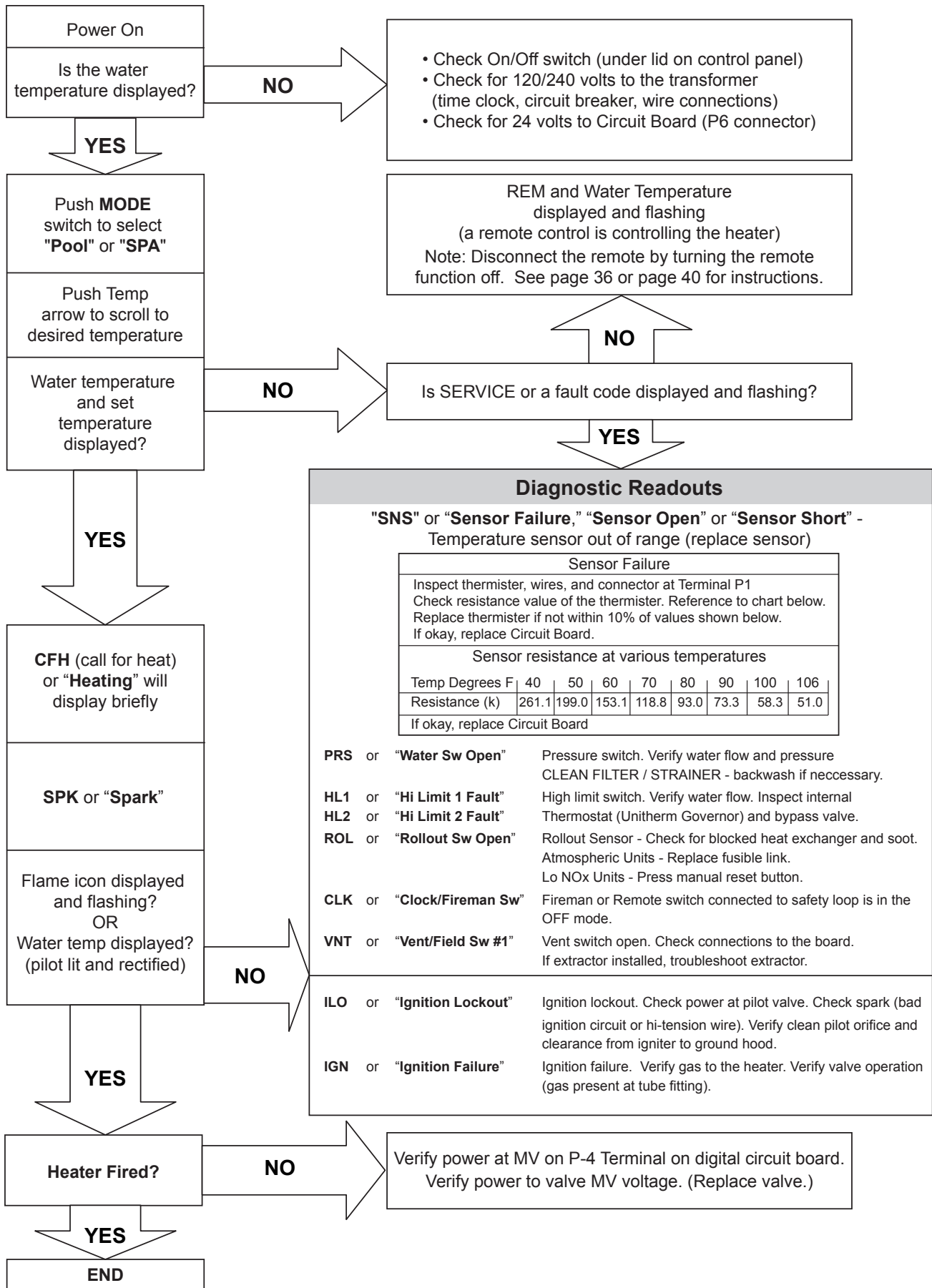

SECTION 6 - REPLACEMENT PARTS

NOTE: To supply you with the correct part, it is important that you supply the heater model number, serial number and type of gas when applicable.

Any part returned for replacement under standard company warranties must be properly tagged with a return parts tag, completely filled in with the heater serial number, model number, etc., and shipped to the Company freight prepaid.

If determined defective by the Company and within warranty, a like part or equal substitution will be returned, freight collect. Credit will not be issued.

MANUFACTURER:

2151 EASTMAN AVENUE
OXNARD, CA 93030

ATMOSPHERIC HEATERS

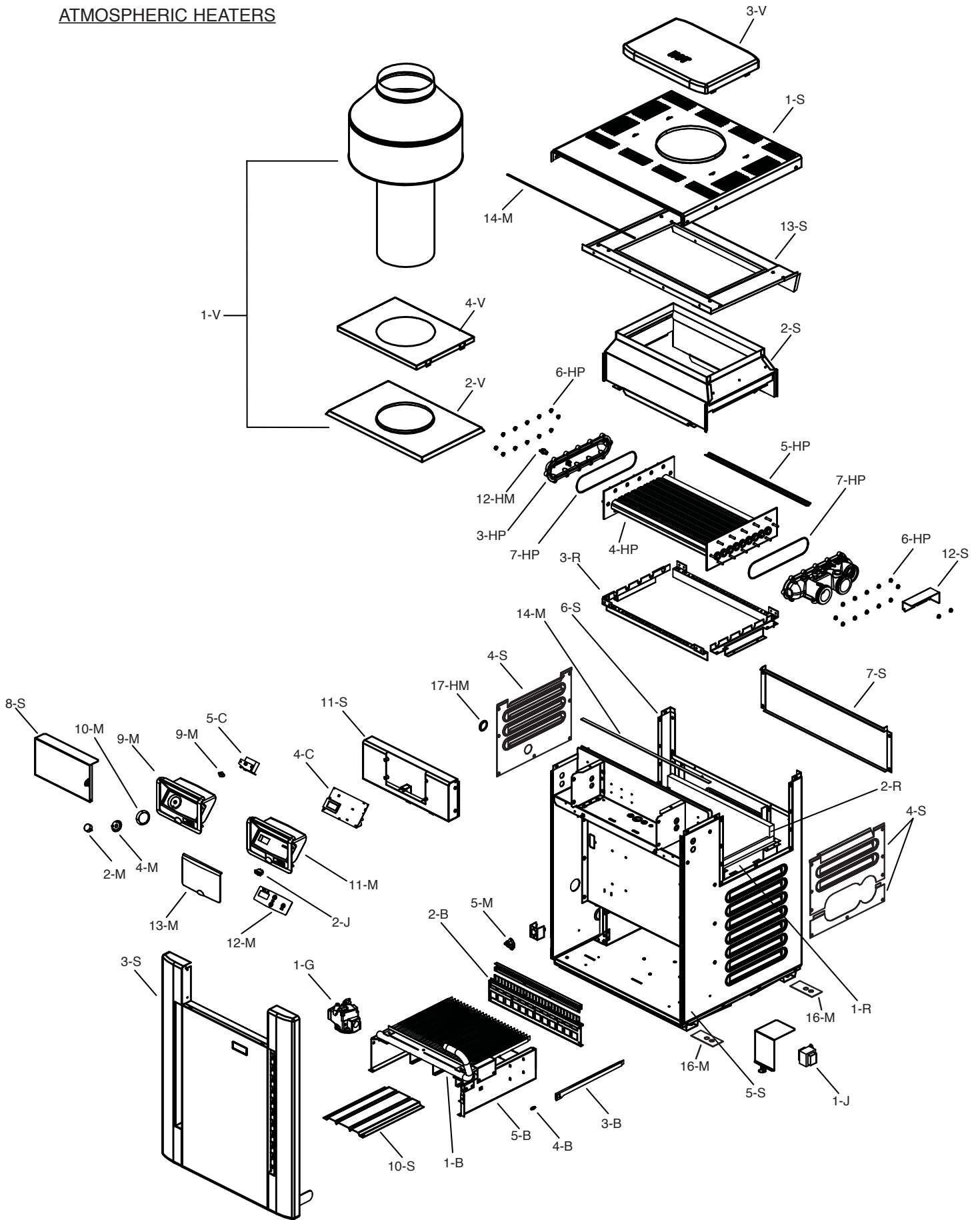

LO NOx HEATERS

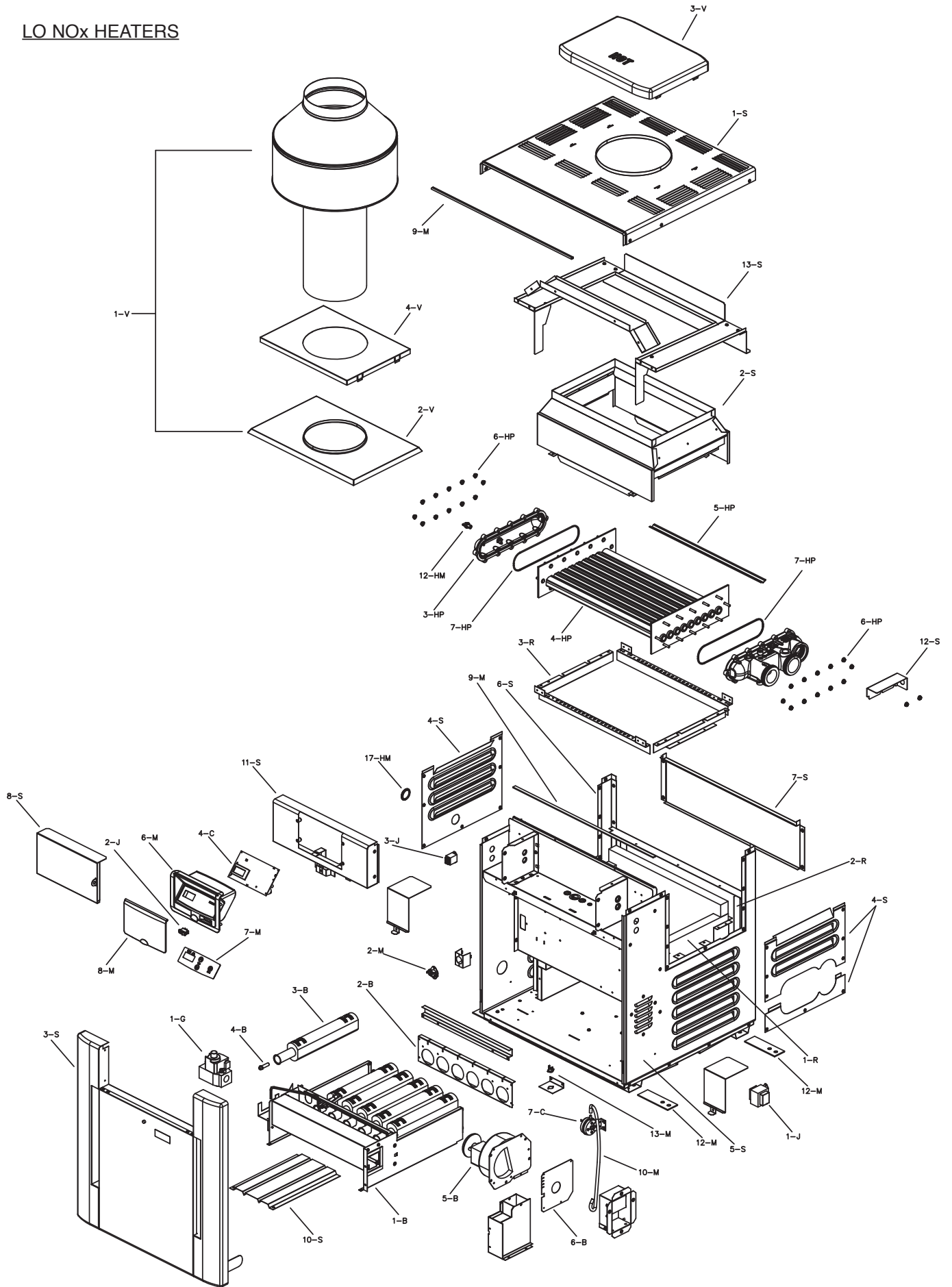

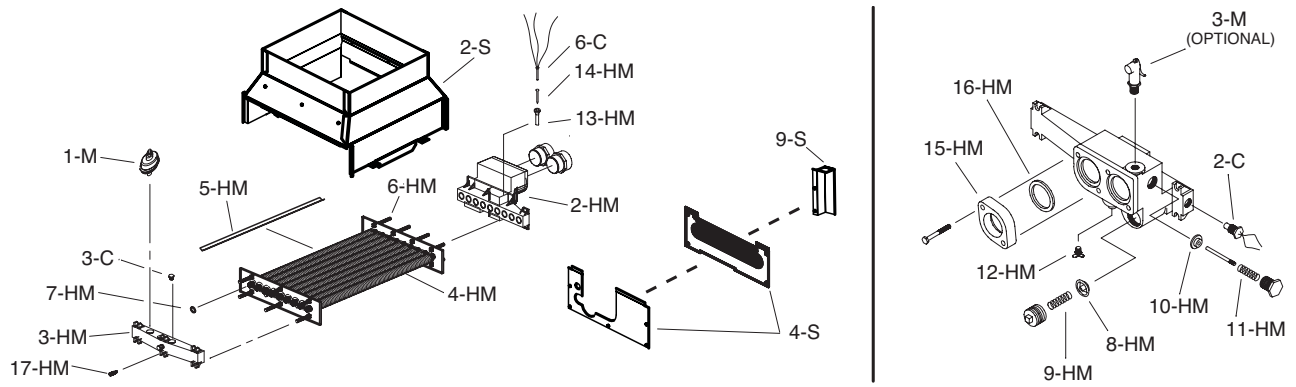

↑ FOR UNITS WITH ASME METAL HEADERS ↑

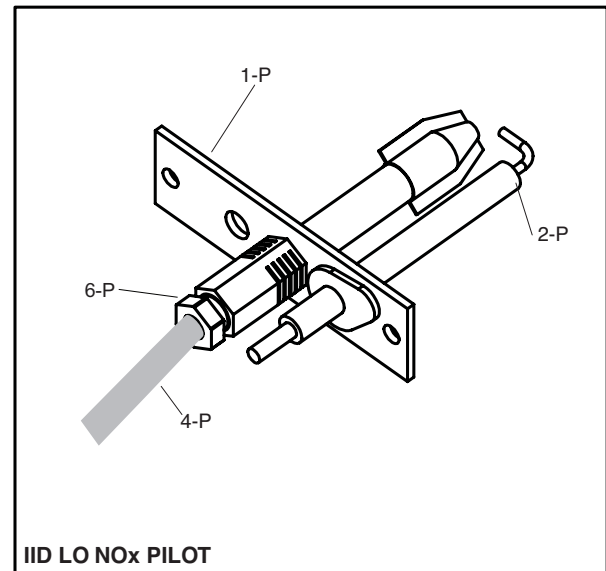
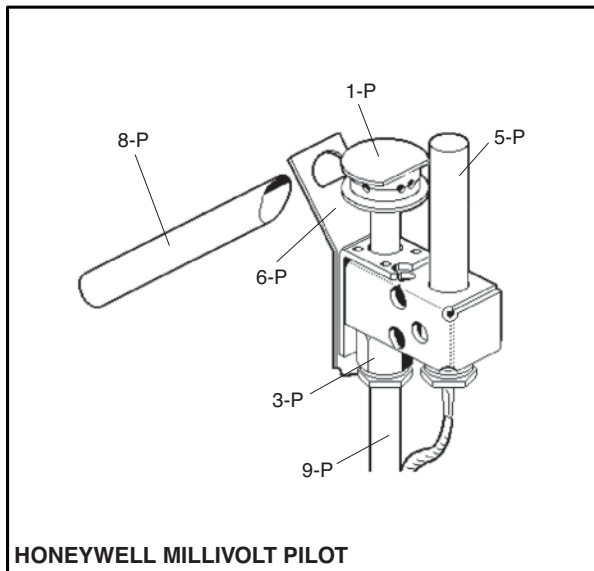
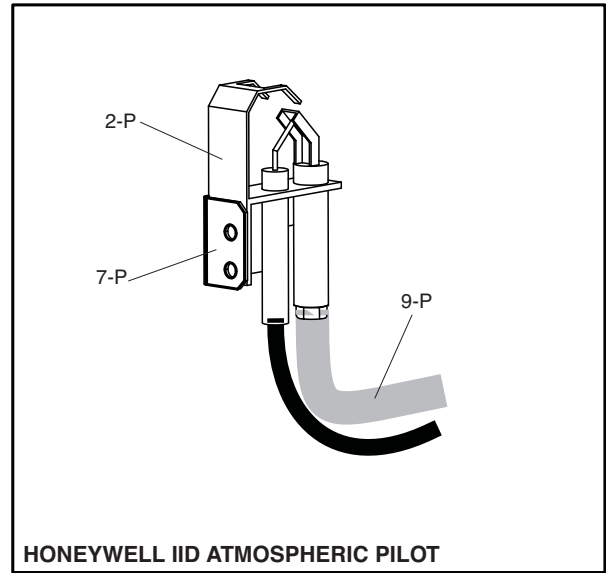
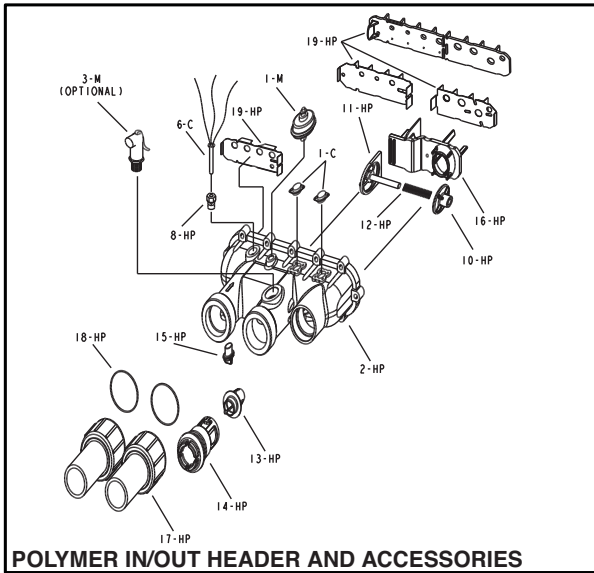

ATMOSPHERIC HEATERS

CALL OUT	DESCRIPTION	206A	266A	336A	406A
B	BURNER TRAY				
1-B	Burner Tray w/Burners (sea level)*	010391F	010392F	010393F	010394F
	Burner Tray w/o Burners (sea level)*	010395F	010396F	010397F	010398F
	Burner Tray w/Gas Valve Nat Millivolt	010399F	010400F	010401F	010402F
	Burner Tray w/Gas Valve Pro Millivolt	010403F	010404F	010405F	010406F
	Burner Tray w/Gas Valve Nat IID	010407F	010408F	010409F	010410F
	Burner Tray w/Gas Valve Pro IID	010411F	010412F	010413F	010414F
2-B	Burner Spacer/Hold Down Kit	010415F	010416F	010417F	010418F
3-B	Burner	301210/13	301210/18	301210/22	301210/27
4-B	Burner Orifice Nat. #50 (Sea Level)*	350079F/13	350079F/18	350079F/22	350079F/27
	Burner Orifice Pro. #57 (Sea Level)*	350083F/13	350083F/18	350083F/22	350083F/27
5-B	Burner Tray w/o Manifold w/o burners	010421F	010422F	010423F	010424F
C	CONTROLS				
1-C	Thermostat Auto Reset 135 Deg Surface Mount	006725F	006725F	006725F	006725F
2-C	AGS 135° (Auto Gas Shut-Off) - Red Epoxy	600892B	600892B	600892B	600892B
3-C	High Limit 140° - Black Epoxy	600893B	600893B	600893B	600893B
4-C	P. C. Board/Control IID Units	013489F	013489F	013489F	013489F
5-C	Thermostat Control MV Units Mechanical	003346F	003346F	003346F	003346F
6-C	Temperature Sensor IID Units	009577F	009577F	009577F	009577F
G	GAS VALVE				
1-G	Combination Valve - Nat. MV	003898F	003898F	003898F	003898F
	Combination Valve - Pro. MV	003899F	003899F	003899F	003899F
	Combination Valve - Nat. IID	003900F	003900F	003900F	003900F
	Combination Valve - Pro. IID	004306F	004306F	004306F	004306F
HP	HEAT EXCHANGER - POLYMER				
1-HP	Heat Exchange Assy Copper	010043F	010044F	010045F	010046F
	Heat Exchange Assy Cupro Nickel	010356F	010357F	010358F	010359F
2-HP	Inlet/Outlet Header Complete	006827F	006827F	006827F	006827F
	Inlet/Outlet Header (Includes 6-HP)	006706F	006706F	006706F	006706F
3-HP	Return Header (Includes 6-HP)	006707F	006707F	006707F	006707F
4-HP	Tube Bundle Copper **	010059F	010060F	010061F	010062F
	Tube Bundle Cupro Nickel **	010364F	010365F	010366F	010367F
5-HP	Baffle	010038F	005261F	010040F	010041F
6-HP	Flange Nut Kit	008259F	008259F	008259F	008259F
7-HP	O Ring Gasket (2)	006713F	006713F	006713F	006713F
8-HP	Sensor Adapter Digital Electronic	006714F	006714F	006714F	006714F
	Sensor Well Millivolt	006805F	006805F	006805F	006805F
9-HP	Bypass Kit	006715F	006715F	006715F	006715F
10-HP	Bypass Valve	006716F	006716F	006716F	006716F
11-HP	Bypass Dam / Shaft	006717F	006717F	006717F	006717F
12-HP	Bypass Spring (All Sizes Included)	006718F	006718F	006718F	006718F
13-HP	Unitherm Governor	006719F	006719F	006719F	006719F
14-HP	Unitherm Governor Plug	006720F	006720F	006720F	006720F
15-HP	Drain Plug	006721F	006721F	006721F	006721F
16-HP	Inlet/Outlet Header Dam	N/A Use 19-HP	N/A Use 19-HP	N/A Use 19-HP	N/A Use 19-HP
17-HP	2" PVC Connector & Nut (2)	006723F	006723F	006723F	006723F
18-HP	O Ring (2)	006724F	006724F	006724F	006724F
19-HP	Inlet/Outlet Header Baffle w/Header Dam	006826F	006826F	006826F	006826F

*FOR INSTALLATION AT OVER 2,000 FEET ABOVE SEA LEVEL, DERATE 4% PER 1,000 FEET ABOVE SEA LEVEL.

**WARNING: The Hydraulic conditions or water chemistry that caused the tube bundle to fail have very likely also damaged the bypass valve and Unitherm Governor. We recommend you replace the Unitherm Governor and inspect the bypass assembly. Failure to do so could cause premature failure of this replacement part.

ATMOSPHERIC HEATERS

CALL OUT	DESCRIPTION	206A	266A	336A	406A
HM	HEAT EXCHANGER - METAL				
1-HM	Heat Exchange Assy.Copper ASME CI	010051F	006727F	010053F	010054F
	Heat Exchange Assy.Cupro Nickel ASME CI	010360F	010361F	010362F	010363F
2-HM	Inlet/Outlet Header ASME CI Complete	006730F	006730F	006730F	006730F
	Inlet/Outlet Header ASME CI	012319F	012319F	012319F	012319F
15-HM	Inlet & Outlet Flange	003766F	003766F	003766F	003766F
16-HM	Flange Gasket 1 1/2" Connections	062236B	062236B	062236B	062236B
	Flange Gasket 2" Connections	800080B	800080B	800080B	800080B
3-HM	Return Header ASME CI	006731F	006731F	006731F	006731F
4-HM	Tube Bundle Copper ASME *	010055F	006733F	010057F	010058F
	Tube Bundle Cupro Nickel ASME *	010368F	010369F	010370F	010371F
5-HM	Baffle	010038F	005261F	010040F	010041F
6-HM	Stud Bolt Kit	007870F	007870F	007870F	007870F
7-HM	Header Gasket (9)	800014B	800014B	800014B	800014B
8-HM	Unitherm Governor	062234B	062234B	062234B	062234B
9-HM	U.G. Retainer Spring	850254	850254	850254	850254
10-HM	Bypass Valve	062235B	062235B	062235B	062235B
11-HM	Bypass Spring	850252	850253	850253	850253
12-HM	Drain Valve	500719	500719	500719	500719
13-HM	Sensor Well	003765F	003765F	003765F	003765F
14-HM	Well Retaining Clip	300203	300203	300203	300203
17-HM	Rear Drain Plug & Cover	005264F	005264F	005264F	005264F
J	CONTROL BOX				
1-J	Transformer 120/240/24V	006736F	006736F	006736F	006736F
2-J	Rocker Switch	009493F	009493F	009493F	009493F
M	MISCELLANEOUS COMPONENTS				
1-M	Pressure Switch 1.75 PSI	006737F	006737F	006737F	006737F
	Pressure Switch 11 PSI Special-See Water Pressure Switch Adj.	009133F	009133F	009133F	009133F
2-M	Thermostat Knob	009499F	009499F	009499F	009499F
3-M	Thermostat Shaft MV	800307	800307	800307	800307
4-M	Knobstop	006886F	006886F	006886F	006886F
5-M	Thermal Fuse	005899F	005899F	005899F	005899F
6-M	PRV 125 PSI (Optional)	008091F	007224F	007224F	007224F
7-M	Delimiting Kit	052871F	052871F	052871F	052871F
8-M	Wire/Harness Millivolt	010386F	010386F	010386F	010386F
	Wire/Harness IID	009490F	009490F	009490F	009490F
9-M	Control Bezel MV (Includes Dial Decal)	009489F	009489F	009489F	009489F
10-M	Dial Decal MV	009858F	009858F	009858F	009858F
11-M	Control Bezel IID (Includes Switch Decal)	009491F	009491F	009491F	009491F
12-M	Switch/Decal-Membrane	009492F	009492F	009492F	009492F
13-M	Control Bezel Cover	009487F	009487F	009487F	009487F
14-M	Gasket Insulation (Swaybrace & Jacket Top)	010350F	010350F	010350F	010350F
15-M	Touch-up Paint (Green)	750125	750125	750125	750125
	Touch-up Paint (Dark Gray)	750126	750126	750126	750126
16-M	Tie Down Bracket (Optional)	011636	011636	011636	011636
17-M	Texas Code Add/On (ASME Only)	012011	012011	012011	012011
P	PILOT				
1-P	Pilot Nat. MV	600525B	600525B	600525B	600525B
	Pilot Pro. MV	600575B	600575B	600575B	600575B
2-P	Pilot Nat & Pro IID	002003F	002003F	002003F	002003F
3-P	Pilot Orifice Nat. MV	003901F	003901F	003901F	003901F
	Pilot Orifice Pro. MV	003902F	003902F	003902F	003902F
4-P	Pilot Orifice Nat. IID .020	003903F	003903F	003903F	003903F
	Pilot Orifice Pro. IID .012	004308F	004308F	004308F	004308F
5-P	Pilot Generator MV	600019B	600019B	600019B	600019B
6-P	Pilot MTG Bracket MV	010352F	010352F	010352F	010352F
7-P	Pilot Mounting Bracket IID	306692	306692	306692	306692
8-P	Lighter Tube (MV Units Only)	062996	062996	062996	062996
9-P	Pilot Tube	004078F	004078F	004078F	004078F
10-P	Hi Tension Wire IID with Pilot Electrode	007864F	007864F	007864F	007864F
11-P	Pilot Shield	010351F	010351F	010351F	010351F
R	REFRACTORY				
1-R	Refractory Common Lt & Rt	010088F	010088F	010088F	010088F
2-R	Refractory Uncommon (Front & Rear)	010089F	010090F	010091F	010092F
3-R	Refractory Retainer Kit	010387F	010388F	010389F	010390F

*WARNING: The Hydraulic conditions or water chemistry that caused the tube bundle to fail have very likely also damaged the bypass valve and Unitherm Governor. We recommend you replace the Unitherm Governor and inspect the bypass assembly. Failure to do so could cause premature failure of this replacement part.

ATMOSPHERIC HEATERS

CALL OUT	DESCRIPTION	206A	266A	336A	406A
S	SHEETMETAL				
1-S	Jacket Top (Louvered)	010047F	010048F	010049F	010050F
2-S	Flue Collector (Units with Polymer Header)	010071F	010072F	010073F	010074F
	Flue Collector (Units with Metal Header)	010075F	010076F	010077F	010078F
3-S	Door Assy.				
	Raypak	010378F	010379F	010380F	010381F
	Rheem	010382F	010383F	010384F	010385F
4-S	Access Panel Set (3 Pcs Units with Polymer Header)	010311F	010311F	010311F	010311F
	Access Panel Set (3 Pcs. Units with Metal Header)	010312F	010312F	010312F	010312F
5-S	Jacket Side Panel Right	010376F	010376F	010376F	010376F
6-S	Jacket Side Panel Left	010377F	010377F	010377F	010377F
7-S	Jacket Rear Panel (2 Pcs.)	010372F	010373F	010374F	010375F
8-S	Poolstat Cover/Lock	009505	009505	009505	009505
9-S	High Limit Cover	010319F	010319F	010319F	010319F
10-S	Base Heat Shield	010320F	010320F	010320F	010320F
11-S	Up Front Control Panel	010321F	010322F	010323F	010324F
12-S	High Limit Shield	010342F	010342F	010342F	010342F
13-S	Weather Shield	010325F	010326F	010327F	010328F
V	VENTING				
1-V	Indoor Stack Kit (Includes inner adapter panel)	009838	009839	009840	009841
	Outdoor Stack Kit (Includes inner adapter panel)	009834	009835	009836	009837
2-V	Stack Adapter	010330F	010331F	010332F	010333F
4-V	Outer Stack Adapter	011461F	011462F	011463F	011464F
3-V	"Pagoda" Top	010334	010335	010336	010337
Atmospheric CONVERSION KITS*		206A	266A	336A	406A
Gas Conversions					
Nat. to Pro. MV Pilot		004690B	004690B	004692B	004692B
Pro. to Nat. MV Pilot		010419F	010419F	010420F	010420F
Nat. to Pro. IID Pilot		**	**	**	**
Pro. to Nat. IID Pilot		**	**	**	**

* Gas conversions are to be done only by a qualified agency.

** Conversion must be made with complete burner tray and gas valve (see item 1-B).

LO NOx HEATERS

CALL OUT	DESCRIPTION	207A	267A	337A	407A
BB	BURNER TRAY***				
1-B	Burner Tray w/Burners (0-5000)	010343F	010344F	010345F	01034
	Burner Tray w/o Burner (0-5000)	010084F	010085F	010086F	01008
2-B	Burner Hold Down Kit	010254F	010255F	010256F	01025
3-B	Burner	310732/3	310732/4	310732/5	31073:
4-B	Burner Orifice Nat. #26 (0-5000)*	351632/3	351632/4	351632/5	35163:
	Burner Orifice Nat. #31 (above 5000 ft.)*	351523/3	351523/4	351523/5	35152:
5-B	Blower	010042F	010042F	010042F	01004
7-B	Cooling Fan	010871F	010871F	010871F	01087
6-B	Combustion Air Orifice Plate	010338F	010339F	010340F	01034
C	CONTROLS				
1-C	Thermostat Auto Reset 135 Deg Surface Mount	006725F	006725F	006725F	00672
2-C	AGS 135° (Auto Gas Shut-Off) - Red Epoxy	600892B	600892B	600892B	60089
3-C	High Limit 140° - Black Epoxy	600893B	600893B	600893B	60089
4-C	P. C. Board/Control				
	Units manufactured prior to 1/2011	013489F	013489F	013489F	01348
	Units manufactured from 1/2011	013464F	013464F	013464F	01346
6-C	Temperature Sensor	009577F	009577F	009577F	00957
7-C	Blower Pressure Switch	008062F	008135F	010354F	01035
G	GAS VALVE				
1-G	Combination Valve - Gas On/Off -Nat	010329F	010329F	010329F	01032
HP	HEAT EXCHANGER - POLYMER				
1-HP	Heat Exchange Assy Copper	010043F	010044F	010045F	01004
	Heat Exchange Assy Cupro Nickel	010356F	010357F	010358F	01035
2-HP	Inlet/Outlet Header Complete	006827F	006827F	006827F	00682
	Inlet/Outlet Header (Includes 6-HP)	006706F	006706F	006706F	00670
3-HP	Return Header (Includes 6-HP)	006707F	006707F	006707F	00670
4-HP	Tube Bundle Copper **	010059F	010060F	010061F	01006
	Tube Bundle Cupro Nickel **	010364F	010365F	010366F	01036
5-HP	Baffle	010038F	005261F	010040F	01004
6-HP	Flange Nut Kit	008259F	008259F	008259F	00825
7-HP	O Ring Gasket (2)	006713F	006713F	006713F	00671
8-HP	Sensor Adapter Digital Electronic	006714F	006714F	006714F	00671
	Sensor Well Millivolt	006805F	006805F	006805F	00680
9-HP	Bypass Kit	006715F	006715F	006715F	00671
10-HP	Bypass Valve	006716F	006716F	006716F	00671
11-HP	Bypass Dam / Shaft	006717F	006717F	006717F	00671
12-HP	Bypass Spring (All Sizes Included)	006718F	006718F	006718F	00671
13-HP	Unitherm Governor	006719F	006719F	006719F	00671
14-HP	Unitherm Governor Plug	006720F	006720F	006720F	00672
15-HP	Drain Plug	006721F	006721F	006721F	00672
16-HP	Inlet/Outlet Header Dam	N/A Use 19-HP	N/A Use 19-HP	N/A Use 19-HP	N/A Use 1
17-HP	2" PVC Connector & Nut (2)	006723F	006723F	006723F	00672
18-HP	O Ring (2)	006724F	006724F	006724F	00672
19-HP	Inlet/Outlet Header Baffle w/Header Dam	006826F	006826F	006826F	00682
HM	HEAT EXCHANGER - METAL				
1-HM	Heat Exchange Assy.Copper ASME CI	010051F	006727F	010053F	01005
	Heat Exchange Assy.Cupro Nickel ASME CI	010360F	010361F	010362F	01036
2-HM	Inlet/Outlet Header ASME CI (Complete)	006730F	006730F	006730F	00673
	Inlet/Outlet Header ASME CI	012319F	012319F	012319F	01231
15-HM	Inlet & Outlet Flange	003766F	003766F	003766F	00376
16-HM	Flange Gasket 1 1/2" Connections	062236B	062236B	062236B	06223
	Flange Gasket 2" Connections	800080B	800080B	800080B	80008
3-HM	Return Header ASME CI	006731F	006731F	006731F	00673
4-HM	Tube Bundle Copper ASME **	010055F	006733F	010057F	01005
	Tube Bundle Cupro Nickel ASME **	010368F	010369F	010370F	01037
5-HM	Baffle	010038F	005261F	010040F	01004
6-HM	Stud Bolt Kit	007870F	007870F	007870F	00787
7-HM	Header Gasket (9)	800014B	800014B	800014B	80001
8-HM	Unitherm Governor	062234B	062234B	062234B	06223
9-HM	U.G. Retainer Spring	850254	850254	850254	85025
10-HM	Bypass Valve	062235B	062235B	062235B	06223
11-HM	Bypass Spring	850252	850253	850253	85025
12-HM	Drain Valve	500719	500719	500719	50071
13-HM	Sensor Well	003765F	003765F	003765F	00376
14-HM	Well Retaining Clip	300203	300203	300203	30020
17-HM	Rear Drain Plug & Cover	005264F	005264F	005264F	00526

*FOR INSTALLATIONS AT OVER 5,000 FEET ABOVE SEA LEVEL, CONSULT THE FACTORY

**WARNING: The Hydraulic conditions or water chemistry that caused the tube bundle to fail have very likely also damaged the bypass valve and Unitherm Governor. We recommend you replace the Unitherm Governor and inspect the bypass assembly. Failure to do so could cause premature failure of this replacement part.

LO NOx HEATERS

CALL OUT	DESCRIPTION	207A	267A	337A	407A
J	CONTROL BOX				
1-J	Transformer 120/240/24V	006736F	006736F	006736F	006736F
2-J	Rocker Switch	009493F	009493F	009493F	009493F
3-J	Relay Low Nox	008784F	008784F	008784F	008784F
M	MISCELLANEOUS COMPONENTS				
1-M	Pressure Switch 1.75 PSI	006737F	006737F	006737F	006737F
	Pressure Switch 11 PSI Special-See Water Pressure Switch Adj.	009133F	009133F	009133F	009133F
2-M	Roll-Out Switch 300°F	006035F	006035F	006035F	006035F
3-M	PRV 125 PSI (Optional)	008091F	007224F	007224F	007224F
4-M	Delimiting Kit	052871F	052871F	052871F	052871F
5-M	Wire/Harness	010347F	010347F	010347F	010347F
6-M	Control Bezel (Includes Switch Decal)				
	Units manufactured prior to 1/2011	009491F	009491F	009491F	009491F
	Units manufactured from 1/2011	013491F	013491F	013491F	013491F
7-M	Switch/Decal-Membrane				
	Units manufactured prior to 1/2011	009492F	009492F	009492F	009492F
	Units manufactured from 1/2011	013492F	013492F	013492F	013492F
8-M	Control Bezel Cover	009487F	009487F	009487F	009487F
9-M	Gasket Insulation (Swaybrace & Jacket Top)	010350F	010350F	010350F	010350F
10-M	Blower / Air Pressure Switch Sample Tube	010348F	010348F	010348F	010348F
11-M	Touch-up Paint (Green)	750125	750125	750125	750125
	Touch-up Paint (Dark Gray)	750126	750126	750126	750126
12-M	Tie Down Bracket (Optional)	011636	011636	011636	011636
13-M	Roll-Out Switch 250°F (Optional)	011745F	011745F	011745F	011745F
	Roll-Out Switch 250°F (Upgrade)	011733F	011733F	011733F	011733F
14-M	Texas Code Add/On (ASME Only)	012011	012011	012011	012011
P	PILOT				
1-P	Pilot Nat. IID Lo NOx	010232F	010232F	010232F	010232F
2-P	Pilot Electrode	N/A	N/A	N/A	N/A
3-P	Pilot Mounting Bracket	010233F	010234F	010235F	010236F
4-P	Pilot Tube	011926F	011926F	011926F	011926F
5-P	Hi Tension Wire IID	010349F	010349F	010349F	010349F
6-P	Adapter Nut (Metric)	011927F	011927F	011927F	011927F
R	REFRACTORY				
1-R	Refractory Common (Left & Right)	010079F	010079F	010079F	010079F
2-R	Refractory Uncommon (Front and Rear)	010080F	010081F	010082F	010083F
3-R	Refractory Retainer Kit	010262F	010263F	010264F	010265F
S	SHEETMETAL				
1-S	Jacket Top (Louvered)	010047F	010048F	010049F	010050F
2-S	Flue Collector (Units with Polymer Header)	010063F	010064F	010065F	010066F
	Flue Collector (Units with Metal Header)	010067F	010068F	010069F	010070F
3-S	Door Assy.				
	Raypak	010267F	010268F	010269F	010270F
	Rheem	010271F	010272F	010273F	010274F
4-S	Access Panel Set (3 Pcs. Units with Polymer Header)	010311F	010311F	010311F	010311F
	Access Panel Set (3 Pcs. Units with Metal Header)	010312F	010312F	010312F	010312F
5-S	Jacket Side Panel Right	010313F	010313F	010313F	010313F
6-S	Jacket Side Panel Left	010314F	010314F	010314F	010314F
7-S	Jacket Rear Panel (2 Pcs.)	010315F	010316F	010317F	010318F
8-S	Poolstat Cover/Lock	009505	009505	009505	009505
9-S	High Limit Cover	010319F	010319F	010319F	010319F
10-S	Base Heat Shield	010320F	010320F	010320F	010320F
11-S	Up Front Control Panel	010321F	010322F	010323F	010324F
12-S	High Limit Shield	010342F	010342F	010342F	010342F
13-S	Weather Shield	010325F	010326F	010327F	010328F
V	VENTING				
1-V	Indoor Stack Kit (Includes inner adapter panel)	009838	009839	009840	009841
	Outdoor Stack Kit (Includes inner adapter panel)	009834	009835	009836	009837
2-V	Stack Adapter	010330F	010331F	010332F	010333F
4-V	Outer Stack Adapter	011461F	011462F	011463F	011464F
3-V	"Pagoda" Top	010334	010335	010336	010337

