

RAYPAK ILLUSTRATED PARTS LIST

The parts listed are for standard equipment for this model type. Raypak reserves the right to substitute, delete or change any part without notification. The addition of options may also change some of the parts. Order replacement parts from actual heater components.

PROFESSIONAL ATMOSPHERIC HEATER

POOL MODELS 268 and 408

DATES OF MANUFACTURE: 09-01-11 THROUGH CURRENT



For detailed instructions, see “How to Use your Raypak Illustrated Parts List”, Catalog No. 9001.10

Raypak[®]
A Rheem[®] Company

CATALOG NO. 9100.561

Effective: 06-12-19

Replaces: 01-01-19

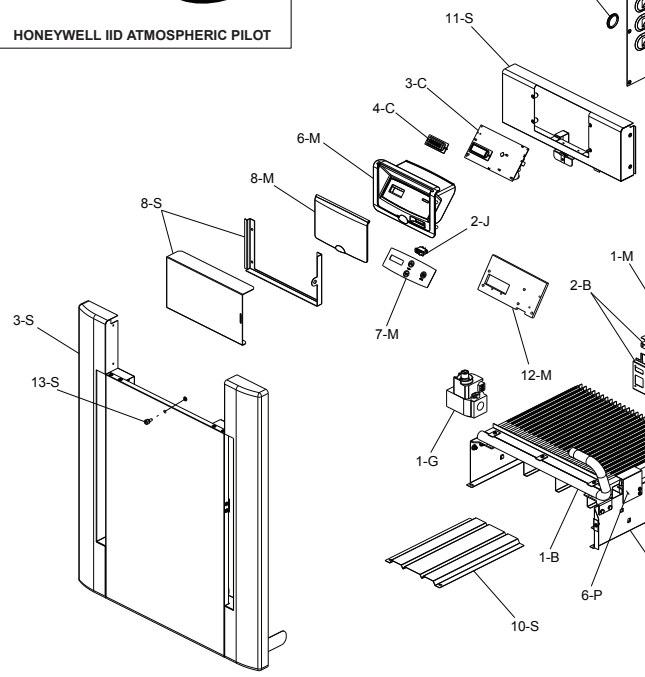
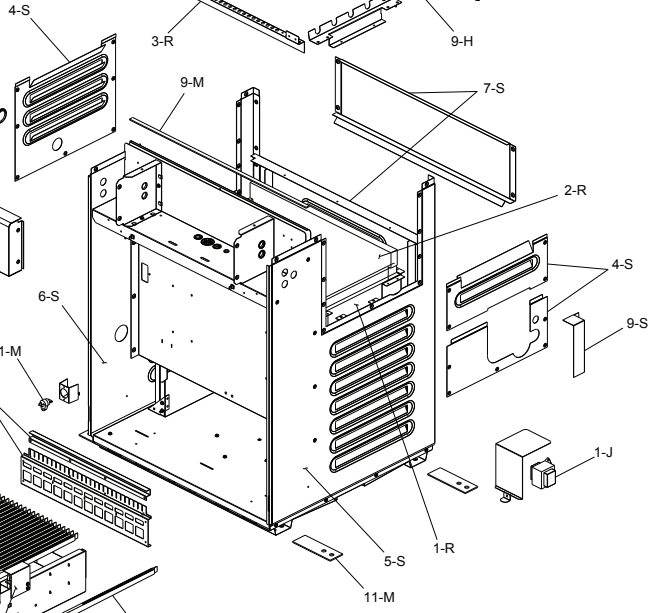
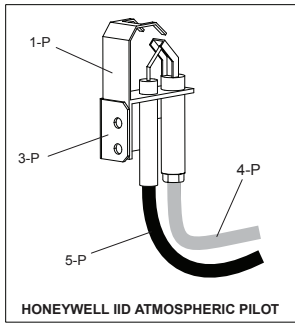
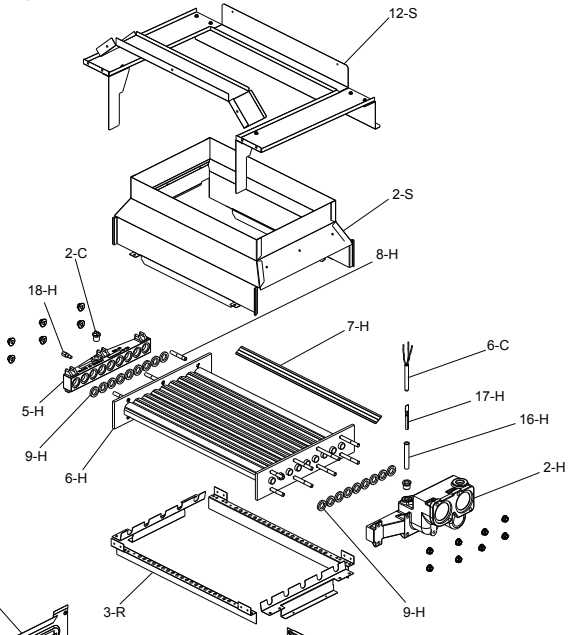
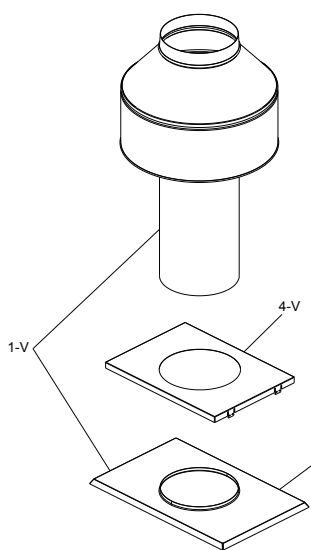
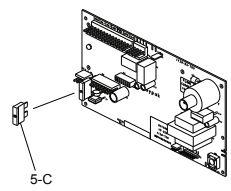
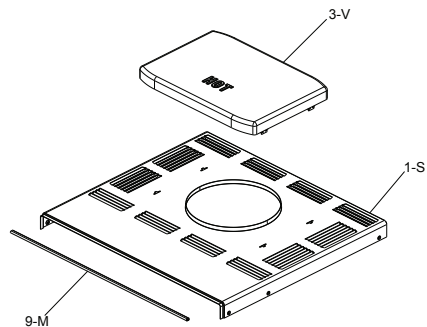
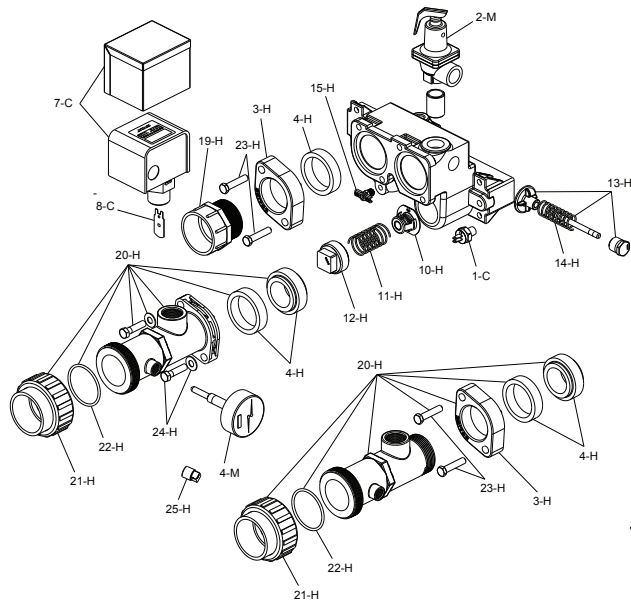

CALL OUT	DESCRIPTION	268A	408A
B	BURNER TRAY		
1-B	Burner Tray w/Burners (sea level)*	013796F	013797F
	Burner Tray w/o Burners (sea level)*	013798F	013799F
	Burner Tray w/Gas Valve Nat	013800F	013801F
	Burner Tray w/Gas Valve Pro	013802F	013803F
2-B	Burner Spacer/Hold Down Kit	013804F	013805F
3-B	Burner	301210/18	301210/27
4-B	Burner Orifice Nat. #50 (Sea Level)*	350079F/18	350079F/27
	Burner Orifice Pro. #57 (Sea Level)*	350083F/18	350083F/27
5-B	Burner Tray w/o Manifold w/o burners	013806F	013807F
C	CONTROLS		
1-C	AGS 135° (Auto Gas Shut-Off) - Red Epoxy	600892B	600892B
2-C	High Limit 140° - Black Epoxy	600893B	600893B
3-C	P. C. Board/Control	013464F	013464F
4-C	LCD Display	013640F	013640F
5-C	Fuse 5 AMP	013733F	013733F
6-C	Temperature Sensor IID Units	009577F	009577F
7-C	Flow Switch	007142F	007142F
8-C	Flow Switch Paddle	010026F	010026F
9-C	Flow Switch Wire Conduit (Not shown)	016161F	016161F
G	GAS VALVE		
1-G	Combination Valve - Nat.	003900F	003900F
	Combination Valve - Pro.	004306F	004306F
H	HEAT EXCHANGER		
1-H	Heat Exchange Assy Cupro-Nickel ASME BR	013808F	013809F
2-H	Inlet/Outlet Header ASME BR Complete	013810F	013810F
	Inlet/Outlet Header ASME BR	013811F	013811F
3-H	Inlet or Outlet Flange BR (1 only)	013812F	013812F
26-H	Flange Gasket 1 1/2" Connection (Not Shown)	062236B	062236B
4-H	Flange Gasket (3)	016732F	016732F
23-H	Flange Bolts	016159F	016159F
5-H	Return Header ASME BR	002451F	002451F
6-H	Tube Bundle Cupro-Nickel ASME **	013813F	013814F
7-H	Baffle	013815F	013816F
8-H	Stud Bolt Kit	007870F	007870F
9-H	Header Gasket (9)	800014B	800014B
10-H	Unitherm Governor	062234B	062234B
11-H	U.G. Retainer Spring	013792F	013792F
12-H	U.G. Plug	013738F	013738F
13-H	Bypass Valve Assembly	016194F	016194F
14-H	Bypass Spring		
	Units with Brass Bypass Valve (Units manufactured prior to 3/5/17)	013794F	013794F
	Units with Plastic Bypass Valve (Units manufactured from 3/5/17)	016196F	016196F
15-H	Drain Valve	013793F	013793F
16-H	Sensor Well	003765F	003765F
17-H	Well Retaining Clip	300203	300203
18-H	Rear Drain Plug & Cover	005264F	005264F
19-H	2" CPVC Adapter NPT (Inlet Plumbing)	005393F	005393F
20-H	2" CPVC Connector (Outlet Plumbing)		
	NPT Connection	013795F	013795F
	Flange Connection	015883F	015883F
21-H	2" CPVC Connector & Nut	006723F	006723F
22-H	O Ring	006724F	006724F
24-H	Flange Bolts & Washers	016162F	016162F
25-H	Pipe Plug Brass 1/4"	016163F	016163F
J	CONTROL BOX		
1-J	Transformer 120/240/24V	006736F	006736F
2-J	Rocker Switch	009493F	009493F

*FOR INSTALLATION AT OVER 2,000 FEET ABOVE SEA LEVEL, DERATE 4% PER 1,000 FEET ABOVE SEA LEVEL

**WARNING: The Hydraulic conditions or water chemistry that caused the tube bundle to fail have very likely also damaged the bypass valve and Unitherm Governor. We recommend you replace the Unitherm Governor and inspect the bypass assembly. Failure to do so could cause premature failure of this replacement part.

CALL OUT	DESCRIPTION	268A	408A
M	MISCELLANEOUS COMPONENTS		
1-M	Thermal Fuse	005899F	005899F
2-M	PRV 125 PSI	011912F	011912F
3-M	Delimiting Kit	052871F	052871F
4-M	T & P Gauge	014647F	014647F
5-M	Wire/Harness	013817F	013817F
6-M	Control Bezel (Includes Switch Decal)	013491F	013491F
7-M	Switch/Decal-Membrane	013492F	013492F
8-M	Control Bezel Cover	009487F	009487F
9-M	Gasket Insulation (Swaybrace & Jacket Top)	010350F	010350F
10-M	Touch-up Paint (Cool Dark Gray)	750256	750256
11-M	Tie Down Bracket (Optional)	011636	011636
12-M	PC Board Shield (Optional)	015557F	015557F
P	PILOT		
1-P	Pilot Nat & Pro	002003F	002003F
2-P	Pilot Orifice Nat .020	003903F	003903F
	Pilot Orifice Pro .012	004308F	004308F
3-P	Pilot Mounting Bracket	013791F	013791F
4-P	Pilot Tube	004078F	004078F
5-P	Hi Tension Wire with Pilot Electrode	N/A	N/A
6-P	Pilot Shield	010351F	010351F
R	REFRACTORY		
1-R	Refractory Common (Left & Right)	010088F	010088F
2-R	Refractory Uncommon (Front & Rear)	010090F	010092F
3-R	Refractory Retainer Kit	010388F	010390F
S	SHEETMETAL		
1-S	Jacket Top (Louvered)	010048F	010050F
2-S	Flue Collector	013818F	013819F
3-S	Door Assy	013820F	013821F
13-S	Screw & Retainer	006744F	006744F
4-S	Access Panel Set (3 Pcs)	010312F	010312F
5-S	Jacket Side Panel Right	010376F	010376F
6-S	Jacket Side Panel Left	010377F	010377F
7-S	Jacket Rear Panel (2 Pcs.)	010373F	010375F
8-S	Control Cover/Lock Box	009505	009505
9-S	High Limit Cover	010319F	010319F
10-S	Base Heat Shield	010320F	010320F
11-S	Up Front Control Panel	013822F	013823F
12-S	Weather Shield	013824F	013825F
V	VENTING		
1-V	Indoor Stack Kit (Includes inner adapter panel)	009839	009841
	Outdoor Stack Kit (Includes inner adapter panel)	009835	009837
2-V	Stack Adapter	010331F	010333F
4-V	Outer Stack Adapter	011462F	011464F
3-V	"Pagoda" Top	013884F	013886F
Atmospheric CONVERSION KITS*		268A	408A
	Nat. to Pro.	**	**
	Pro. to Nat.	**	**

* Gas conversions are to be done only by a qualified agency.

** Conversion must be made with complete burner tray with gas valve (see item 1-B).



www.raypak.com

Raypak, Inc., 2151 Eastman Avenue, Oxnard, CA 93030 (805) 278-5300 FAX (805) 278-5489

Litho In U.S.A.