

INSTALLATION & OPERATING INSTRUCTIONS

84 Professional Gas-Fired Pool & Spa Heater



**Low NOx Models
259B & 409B**



WARNING: If these instructions are not followed exactly, a fire or explosion may result causing property damage, personal injury or death.

Do not store or use gasoline or other flammable vapors and liquids in the vicinity of this or any other appliance.

WHAT TO DO IF YOU SMELL GAS:

- Do not try to light any appliance.
- Do not touch any electrical switch; do not use any phone in your building.
- Immediately call your gas supplier from a neighbor's phone. Follow the gas supplier's instructions.
- If you cannot reach your gas supplier, call the fire department.

Installation and service must be performed by a qualified installer, service agency or the gas supplier.

This manual should be maintained in legible condition and kept adjacent to the heater or in a safe place for future reference.

WATER CHEMISTRY
(Corrosive water voids all warranties)

For your health and the protection of your pool equipment, it is essential that your water be chemically balanced. The following levels must be used as a guide for balanced water.

Recommended Level(s)	Fiberglass Pools	Fiberglass Spas	Other Pool & Spa Types
Water Temp. (Deg. F)	68 to 88	89 to 104	68 to 104
pH	7.3 to 7.4	7.3 to 7.4	7.6 to 7.8
Total Alkalinity (PPM)	120 to 150	120 to 150	80 to 120
Calcium Hardness (PPM)	200 to 300	150 to 200	200 to 400
Salt (PPM)	4500 MAXIMUM	4500 MAXIMUM	4500 MAXIMUM
Free Chlorine (PPM)*	2 to 3	2 to 3	2 to 3
Total Dissolved Solids (PPM)	3000 MAXIMUM**	3000 MAXIMUM**	3000 MAXIMUM**

*** Free Chlorine MUST NOT EXCEED 5 PPM!**

** In salt water chlorinated pools, the total TDS can be as high as 6000 ppm.

- Occasional chemical shock dosing of the pool or spa water should not damage the heater providing the water is balanced.
- Automatic chemical dosing devices and salt chlorinators are usually more efficient in heated water, unless controlled, they can lead to excessive chlorine level **which can damage your heater, and which is not covered under warranty.** A check valve should be installed between the heater outlet and a chlorinator or other chemical dosing device.
- Further advice should be obtained from your pool or spa builder, accredited pool shop, or chemical supplier for the correct levels for your water.

Rev. 8 reflects the following changes:

Updated illustration on page 44.

Updated parts list on page 46.

CONTENTS

2	Water Chemistry	27	Transformer Wiring
4	WARNINGS	28	Optional Left-Hand Wiring
5	PART ONE OWNER'S OPERATING INSTRUCTIONS	28	Plumbing—Water Connections
5	SECTION 1 START-UP PROCEDURES	29	Loose Plumbing Parts
6	SECTION 2 CAUTION	32	Wiring Diagram
6	SECTION 3 MAINTENANCE & CARE PROCEDURES	33	SECTION 4 SERVICING INSTRUCTIONS
7	Lighting & Shutdown Instructions	33	General Location of Controls
8	Pool & Spa Water Chemistry	34	Control Adjustments
8	Automatic Chlorinators & Chemical Feeders	34	Control Panel Removal
8	Cold Weather Operation	35	Thermostat Operation - Direct Spark Board
8	Winterizing the Pool & Spa Heater	37	Status and Diagnostics
9	PART TWO INSTALLATION & SERVICE INSTRUCTIONS	38	Remote Control Installation and Operation
9	SECTION 1 RECEIVING EQUIPMENT	38	Remote Operation
10	SECTION 2 GENERAL SPECIFICATIONS	38	Activating the Remote
10	SECTION 3 INSTALLATION INSTRUCTIONS	39	Remote Control Wiring
10	Code Requirements	39	2-Wire Remote Control
11	Clearances	39	3-Wire Remote Control
11	Outdoor Heater Installation	40	Time Clock / Fireman's Switch
13	Florida Building Code	40	High Limits
14	Indoor Heater Installation	40	Flow Switch
14	Specifications and Dimensions	40	Air Pressure & Blocked Vent Switches
16	Combustion and Ventilation Air	40	Adjusting Valve Manifold Pressure
16	Direct Vent & Ducted Combustion Air Systems	41	Visual Inspection
17	Venting	41	Electrical
18	Support of Vent Stack	41	Orifice Removal
18	Vent Terminal Location	41	Gas and Orifice Selection
19	Venting Installation Tips	41	Igniter Removal
19	Venting Configurations	42	SECTION 5 TROUBLESHOOTING
19	Natural Draft Vertical Venting (Category I) Fan-Assisted	42	Mechanical
20	Horizontal Through-the-Wall Direct Venting (Category III) Fan-Assisted	43	Control Logic - Flow Chart
21	Direct Vent - Horizontal	44	SECTION 6 REPLACEMENT PARTS
22	Direct Vent - Vertical	44	Illustrated Parts List
23	Outdoor Installation	45	Part Numbers
24	Gas Supply Connections	47	Important Instructions for the Commonwealth of Massachusetts
24	Gas Pressure Adjustment Locations		
25	Pipe Sizing For Gas Connections		
24	Heat Exchanger Pressure Drop Tables		
25	Flow Rates		
25	Internal Automatic Bypass Valve		
25	External Auxiliary Bypass Valve		
25	Auxiliary Bypass Valve Adjustment		
25	Pressure Relief Valve Installation		
26	Electrical Wiring		

WARNINGS—Pay Attention to These Terms

DANGER:	Indicates the presence of immediate hazards which will cause severe personal injury, death or substantial property damage if ignored.
WARNING:	Indicates the presence of hazards or unsafe practices which could cause severe personal injury, death or substantial property damage if ignored.
CAUTION:	Indicates the presence of hazards or unsafe practices which could cause minor personal injury or product or property damage if ignored.
NOTE:	Indicates special instructions on installation, operation, or maintenance which are important but not related to personal injury hazards.

DANGER: Failure to install the draft hood on indoor installations and properly vent the heater to the outdoors as outlined in the Venting section of this manual can result in unsafe operation of the heater. To avoid the risk of fire, explosion, or asphyxiation from carbon monoxide, never operate this heater unless it is properly vented and has an adequate air supply for proper operation. Be sure to inspect the vent system for proper installation at initial start-up; and at least annually thereafter. Refer to the Maintenance section of this manual for more information regarding vent system inspections.

DANGER: Make sure the gas on which the heater will operate is the same type as that specified on the heater rating plate.

DANGER: When servicing or replacing components that are in direct contact with the water, be certain that:

- There is no pressure in the heater. (Pull the release on the relief valve. Do not depend on the pressure gauge reading).
- The heater water is not hot.
- The electrical power is off.

WARNING: All venting types must be of the same material or product throughout the entire exhaust installation to ensure proper securing and sealing.

WARNING: Altering any Raypak pressure vessel by installing replacement heat exchangers, tube bundle headers, or any ASME parts not manufactured and/or approved by Raypak will instantly void the ASME and/or CSA ratings of the vessel and any Raypak warranty on the vessel. Altering the ASME and/or CSA ratings of the vessel also violates national, state, and local approval codes.

WARNING: Both natural gas and propane have an odorant added to aid in detecting a gas leak. Some people may not physically be able to smell or recognize this odorant. If you are unsure or unfamiliar with the smell of natural gas or propane, ask your local gas supplier. Other conditions, such as "odorant fade," which causes the odorant to diminish in intensity, can also hide, camouflage, or otherwise make detecting a gas leak by smell more difficult.

WARNING: UL recognized fuel gas detectors are recommended in all enclosed propane and natural gas applications wherein there is a potential for an explosive mixture of fuel gas to accumulate and their installation should be in accordance with the detector manufacturer's recommendations and/or local laws, rules, regulations, or customs.

WARNING: This product must be installed by a licensed plumber or gas fitter when installed within the Commonwealth of Massachusetts.

WARNING: Do not install within 3 feet of a heat pump or an outdoor condensing unit. Strong air intake from this type of equipment can disturb the combustion process and cause damage or personal injury.

WARNING: Do not use this heater if any part has been under water. Immediately call a qualified service technician to inspect the heater and to replace any part of the control system and any gas control which has been under water.

PART ONE OWNER'S OPERATING INSTRUCTIONS

FOR YOUR SAFETY - READ BEFORE OPERATING
WARNING: IF YOU DO NOT FOLLOW THESE INSTRUCTIONS EXACTLY, A FIRE OR EXPLOSION MAY RESULT, CAUSING PROPERTY DAMAGE, PERSONAL INJURY OR LOSS OF LIFE.

INTRODUCTION

Your pool/spa heater has been designed for years of safe and reliable pool/spa water heating. It is available with electronic ignition. This manual provides installation, operation, maintenance, and service information for these heaters.

If your heater has been installed correctly, operating the heater is an easy task. The upper front panel of the heater contains the control center that allows you to turn the heater On or Off and adjust the temperature settings for the pool or spa. The temperature range is factory set from 50°F (18°C) to 104°F (40°C). See figure above for location of toggle switch to turn the heater On and Off. Section 4 of this manual contains more details about the use of the controls in the Control Adjustments subsection (page 34).

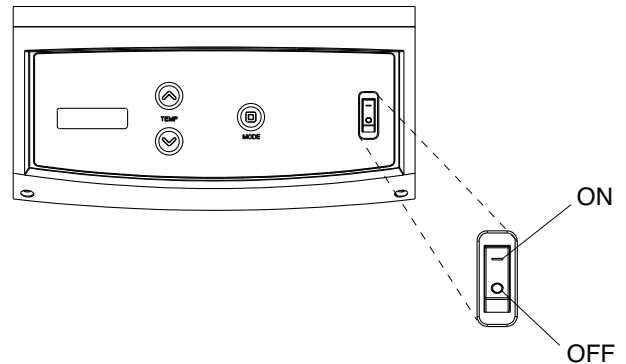

Fig. 1: Control Center

SECTION 1 - START-UP PROCEDURE

- Clean air louvers of dust, lint and debris.
- Keep heater area clear and free from combustibles, flammable liquids and chemicals.
- Verify that the flow of combustion and ventilation air is not obstructed.
- Water must be flowing through the heater during operation. Ensure that the system is filled with water and the pump is operating. Double check for any water leaks.
- Purge air from the gas line. Insufficient purging may keep the heater from lighting on the first try.
- Double check gas connections, make sure no leaks are present. Use soapy water to inspect.
- Double check incoming electrical power, verify sufficient output voltage to the heater.
- The unit comes wired for 240V/1ph/60Hz power. If the supply voltage is nominally 120V/1ph/60Hz, switch the blower harness located inside the cabinet (see wiring diagram).
- If installed indoors, make sure flue gases are vented properly, and that combustion and makeup air openings are adequate.
- Locate and turn the gas valve ON.
- Locate the plugged bleedle valve off the right side of the gas valve.
- Remove the bleedle plug and connect a manometer to the valve.
- Locate and flip the display lid upwards.
- Turn the heater on, by pressing the ON/OFF toggle switch on the front display.
- Set the mode to either SPA or POOL.
- If the set point is higher than the current temperature, the heater will begin its startup sequence.
- The ignition control will verify that the blower air switch is open before starting the blower. Once proven open, the blower will be powered to start the ignition sequence. Verify suction pressure matches the table below, Blower Suction Pressure, for your model heater during the pre-purge period.
- Once the blower air switch proves, a 45 second pre-purge period will begin to purge residual gases from the combustion chamber.

Model	Elevation	Blower Suction
259B	0-2000 ft.	-3.5 to -3.8 "WC
	2000-5000 ft.	-3.1 to -3.6 "WC
	5000-7000 ft.	-2.8 to -3.2 "WC
409B	0-2000 ft.	-3.7 to -4.0 "WC
	2000-5000 ft.	-3.3 to -3.8 "WC
	5000-7000 ft.	-3.0 to -3.4 "WC

Table A: Blower Suction Pressure

19. Once the pre-purge period ends, the igniter will begin to spark just prior to the gas valve opening. The gas valve will open for a 4 second trial for ignition. If flame is proven, the heater will operate to meet heat demand. If flame is not proven, the heater will enter a post-purge period and then retry the ignition cycle or lockout, depending on the heater configuration.
20. Once gas is flowing, the manometer reading will drop to $-0.40'' \pm .1''$ WC. See the instructions on page 40 for adjusting the valve manifold pressure if the reading is not within tolerance.
21. Visually check through the sight glass that the heater is on and heating. A yellowish glow coming from the refractory indicates that the heater is running. The flame should be a blueish color.
22. Remove the manometer and replace with bleedle plug.
23. Reinstall front door panel and knurled screw holding the door in place.
24. Feel the inlet and outlet pipes. Outlet pipe should be only slightly warmer than the inlet. It should not be hot.

SECTION 2 - CAUTION

Elevated water temperature can be hazardous. The U.S. Consumer Product Safety Commission has these guidelines:

1. Spa water temperatures should never exceed 104°F (40°C). A temperature of 100°F (38°C) is considered safe for a healthy adult. Special caution is suggested for young children.
2. Drinking of alcoholic beverages before or during spa or hot tub use can cause drowsiness which could lead to unconsciousness and subsequently result in drowning.
3. *Pregnant Women Beware!* Soaking in water over 102°F (39°C) can cause fetal damage during the first three months of pregnancy resulting in the birth of a brain-damaged or deformed child. Pregnant women should stick to the 100°F (38°C) maximum rule.
4. Before entering the spa or hot tub, users should check the water temperature with an accurate thermometer; spa or hot tub thermostats may err in regulating water temperatures by as much as 4°F (2.2°C).

5. Persons with a medical history of heart disease, circulatory problems, diabetes, or blood pressure problems should obtain a physician's advice before using pools or hot tubs.
6. Persons taking medications which induce drowsiness, such as tranquilizers, antihistamines, or anti-coagulants, should not use spas or hot tubs.

SECTION 3 - MAINTENANCE AND CARE PROCEDURES

WARNING: *Check the heater for possible rodent nests after long periods of non-use.*

To be followed one month after start-up and then semi-annually.

1. Inspect and operate all controls, gas valve and pressure relief valve.
2. On indoor heaters, clean room intake openings to ensure adequate flow of combustion and ventilation air.

CAUTION: *Combustion air must not be contaminated by corrosive chemical fumes which can damage the heater and void the warranty.*

3. Keep area around heater clear and free from combustible materials, gasoline and other flammable and corrosive vapors and liquids.

IF HEATER WILL NOT FIRE:

If you have no electrical power, it may be that your "circuit breaker" has tripped. Try re-setting it.

If you have electrical power but the heater will not fire check the following or see Troubleshooting section:

1. The time clock must be in the "ON" position.
2. Your pump strainer basket may be full. If so remove debris.
3. Your filter may be dirty. If so, backwash or clean filter. (To tell if your filter is dirty, look to see if the filter pressure will be higher than usual).
4. The pump may have lost its prime and be running dry. Check the pressure on the filter. If there is no pressure; then you are not moving water (or your gauge is broken). Try to get the pump to run at its normal flow rate.

Lighting & Shutdown Instructions

WARNING: Should overheating occur or the gas supply fail to shut off, turn off the manual gas control to the heater.

CAUTION: Propane gas is heavier than air and will settle on the ground. Since propane can accumulate in confined areas, extra care should be exercised when lighting propane heaters.

FOR YOUR SAFETY READ BEFORE OPERATING POUR VOTRE SÉCURITÉ LISEZ AVANT DE METTRE EN MARCHÉ

WARNING: If you do not follow these instructions exactly, a fire or explosion may result causing property damage, personal injury or loss of life.

AVERTISSEMENT: Quiconque ne respecte pas à la lettre les instructions dans la présente notice risque de déclencher un incendie ou une explosion entraînant des dommages, des blessures ou la mort.

- A. This appliance does not have a pilot. It is equipped with an ignition device which automatically lights the burner. Do not try to light the burner by hand.
- B. BEFORE OPERATING smell all around the appliance area for gas. Be sure to smell next to the floor because some gas is heavier than air and will settle on the floor.
- WHAT TO DO IF YOU SMELL GAS**
- * Do not try to light any appliance.
 - * Do not touch any electric switch; do not use any phone in your building.
 - * Immediately call your gas supplier from a neighbor's phone.
 - Follow the gas supplier's instructions.
 - * If you cannot reach your gas supplier, call the fire department.
- C. Use only your hand to turn the gas control ON or OFF. Never use tools. If you cannot change the ON/OFF setting by hand, do not try to repair it, call a qualified service technician. Force or attempted repair may result in a fire or explosion.
- D. Do not use this appliance if any part has been under water. Immediately call a qualified service to inspect the appliance and to replace any part of the control system and any gas control which has been under water.

- A. Cet appareil ne comporte pas de veilleuse. Il est muni d'un dispositif d'allumage qui allume automatiquement le brûleur. Ne tentez pas d'allumer le brûleur manuellement.
- B. AVANT DE FAIRE FONCTIONNER, reniflez tout autour de l'appareil pour déceler une odeur de gaz. Reniflez près du plancher, car certains gaz sont plus lourds que l'air et peuvent s'accumuler au niveau du sol.
- QUE FAIRE SI VOUS SENTEZ UNE ODEUR DE GAZ:**
- * Ne pas tenter d'allumer d'appareil.
 - * Ne touchez à aucun interrupteur; ne pas vous servir des téléphones se trouvant dans le bâtiment.
 - * Appelez immédiatement votre fournisseur de gaz depuis un voisin. Suivez les instructions du fournisseur.
 - * Si vous ne pouvez rejoindre le fournisseur, appelez le service des incendies.
- C. Utilisez seulement votre main pour tourner le contrôle du gaz "Marche" (ON) ou "D'Arrêt" (OFF). N'utilisez jamais d'outils. Si vous ne pouvez pas changer le réglage "Marche / D'Arrêt" (ON / OFF) à la main, ne pas essayer de le réparer, appelez un technicien qualifié.
- D. N'utilisez pas cet appareil s'il a été plongé dans l'eau même partiellement. Faites inspecter l'appareil par un technicien qualifié et remplacez toute partie du système de contrôle et toute commande qui ont été plongés dans l'eau.

OPERATING INSTRUCTIONS INSTRUCTIONS DE MISE EN MARCHÉ

1. **STOP!** Read the safety information above on this label.
2. Set the thermostat to the lowest setting.
3. Turn off all electric power to the appliance.
4. This appliance does not have a pilot. It is equipped with an ignition device which automatically lights the burner. Do not try to light the burner by hand.
5. Remove heater door panel.
6. Pull toggle style switch away from you to turn gas "OFF".
7. Wait five (5) minutes to clear out any gas. Then smell for gas, including near the floor. If you smell gas **STOP!** Follow "B" in the safety information above on this label. If you don't smell gas, go to the next step.
8. Push the toggle switch towards you to turn the gas "ON".
9. Replace heater door panel.
10. Turn on all electric power to the appliance.
11. Set thermostat to desired setting.
12. If the appliance will not operate, follow the instructions "To Turn Off Gas To Appliance" and call your service technician or gas supplier.

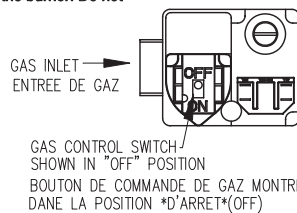

1. **ARRÊTEZ!** Lisez les instructions de sécurité sur la portion supérieure de cette étiquette.
2. Réglez le thermostat à la température la plus basse.
3. Coupez l'alimentation électrique de l'appareil.
4. Cet appareil ne comporte pas de veilleuse. Il est muni d'un dispositif d'allumage qui allume automatiquement le brûleur. Ne tentez pas d'allumer le brûleur manuellement.
5. Enlevez le panneau de porte du réchauffeur.
6. Interrupteur à tirette de style bascule loin de vous à tourner à gaz "D'Arrêt" (OFF).
7. Attendre cinq (5) minutes pour laisser échapper tout le gaz. Reniflez tout autour de l'appareil, y compris près du plancher, pour déceler une odeur de gaz. Si vous sentez une odeur de gaz, **ARRÊTEZ!** Passez à l'étape "B" des instructions de sécurité sur la portion supérieure de cette étiquette. S'il n'y a pas d'odeur de gaz, passez à l'étape suivante.
8. Poussez l'interrupteur à bascule vers vous pour transformer le gaz "Marche" (ON).
9. Reposez le panneau de porte du réchauffeur.
10. Mettez l'appareil sous tension.
11. Réglez le thermostat à la température désirée.
12. Si l'appareil ne se met pas en marche, suivez les instructions intitulées "Comment couper l'admission de gaz de l'appareil" et appelez un technicien qualifié ou le fournisseur de gaz.

TO TURN OFF GAS TO APPLIANCE COMMENT COUPER L'ADMISSION DE GAZ L'APPAREIL

1. Set the thermostat to the lowest setting.
2. Turn off all electrical power to the appliance if service is to be performed.
3. Remove heater door panel.
4. Pull toggle style switch away from you to turn gas "OFF".
5. Replace heater door panel.

1. Réglez le thermostat à la température la plus basse.
2. Coupez l'alimentation électrique de l'appareil s'il faut procéder à l'entretien.
3. Enlevez le panneau de porte du réchauffeur.
4. Interrupteur à tirette de style bascule loin de vous à tourner à gaz "D'Arrêt" (OFF).
5. Reposez le panneau de porte du réchauffeur.

P/N 902025 REV 1

Fig. 2: Lighting & Shutdown Instructions

POOL & SPA WATER CHEMISTRY

Chemical imbalance can cause severe damage to your heater and associated equipment. Maintain your water chemistry according to the chart on page 2. If the mineral content and dissolved solids in the water become too high, scale forms inside the heat exchanger tube, reducing heater efficiency and damaging the heater. If the pH drops below 7.2, this will cause corrosion of the heat exchanger and severely damage the heater. **Heat exchanger damage resulting from chemical imbalance is not covered by the warranty.**

AUTOMATIC CHLORINATORS AND CHEMICAL FEEDERS

All chemicals must be introduced and completely diluted into the pool or spa water before being circulated through the heater. Do not place sanitizing chemicals in the skimmer. High chemical concentrations will result when the pump is not running (e.g. overnight).

Chlorinators must feed downstream of the heater and have an anti-siphoning device to prevent chemical back-up into the heater when the pump is shut off. A check valve should be installed between the heater outlet and the chlorinator.

See plumbing diagrams on page 30 and 31.

NOTE: *High chemical concentrates from feeders and chlorinators that are out of adjustment will cause rapid corrosion to the heat exchanger. **Such damage is not covered under the warranty.***

COLD WEATHER OPERATION

IMPORTANT FREEZE INFORMATION

MODERATE CLIMATE: Heater operation can continue during short-term cold spells. When temperatures are between 0°F and 32°F, flow (continuous pump operation) must be maintained.

CAUTION: *Do not use the heater to maintain water temperatures just above freezing or for freeze protection. When heater is used during freezing weather, care must be taken to avoid freeze-ups. Continuous pump operation is a must. Additional protection may be required. The heater is not warranted against freeze-ups.*

COLD CLIMATE: Prolonged operation with water temperatures below 50°F is not recommended. When starting the heater with water temperatures below 50°F, operate the heater continuously until higher temperatures are reached. Operating the heater for prolonged periods with pool water below 50°F can seriously damage the heater, and is not covered by the warranty.

For freezing climate areas, please follow the winterizing procedures listed.

WINTERIZING THE POOL & SPA HEATER

Heaters installed outdoors in freezing climate areas may be shut down for the winter. Observe the following procedure for winterizing the heater:

1. Turn off gas valve, manual gas valve, and electrical supply to the heater.
2. Open the drain valve located on the inlet/outlet header (at the lowest point). Pull the PRV handle upwards to allow air in while the water drains through the valve.

PART TWO INSTALLATION AND SERVICE INSTRUCTIONS

SECTION 1 - RECEIVING EQUIPMENT

The manufacturer recommends that this manual be reviewed thoroughly before installing your pool/spa heater. If there are any questions that this manual does not answer, please contact the factory or your local representative.

On receipt of your equipment it is suggested that you visually check for external damage to the carton. If the carton is damaged, a note should be made on the Bill of Lading when signing for the equipment. Remove the heater from the carton. If it is damaged, report the damage to the carrier immediately. Save the carton.

These items are shipped inside a box in the carton with the heater:

STANDARD UNIT

- | | |
|--|---|
| 1. (1) Plastic Pipe Finish Flange for Gas Line | 9. (2) 3-1/2" Vinyl Grommets |
| 2. (1) Bonding Lug with Mounting Screw | 10. (1) 2" CPVC Slip Tee |
| 3. (3) 2" CPVC Slip x Slip Nipples | 11. (1) 2" x 1" CPVC Slip x FPT Bushing |
| 4. (2) 2" CPVC Slip x MPT Adapters | 12. (1) Flow Switch with Paddle |
| 5. (2) 2" CPVC Buttress Tail Pieces | 13. (1) Flow Switch Cover |
| 6. (2) O-Rings | 14. (1) IOI Manual |
| 7. (2) 2" CPVC Slip Tail Pieces | 15. (2) Warranty Documentation |
| 8. (2) 2" CPVC Ring Nuts | 16. (1) ASME Data Certification |

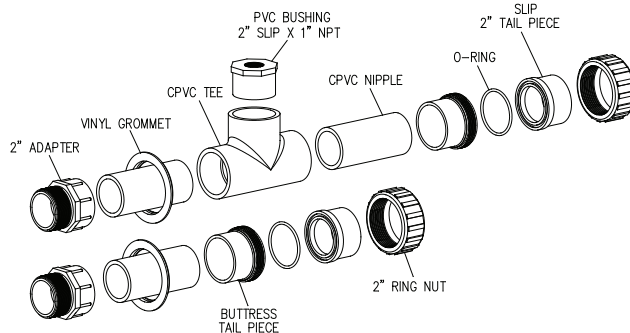

Fig. 3: Loose Parts

Be sure that you receive the number of packages indicated on the Bill of Lading.

When ordering parts, you must specify the model and serial numbers of the heater. See below for location of serial number. When ordering under warranty conditions, you must also specify date of installation.

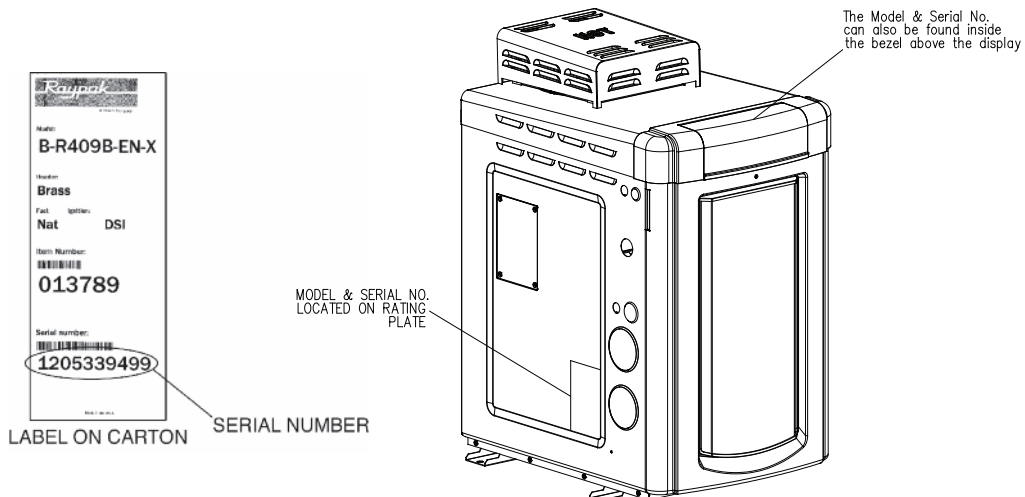

Fig. 4: Unit Identification

SECTION 2 - GENERAL SPECIFICATIONS

These heaters are design-certified and tested under the latest requirements of the ANSI Z21.56 / CSA 4.7 Standard for Gas-Fired Pool Heaters. Each heater has been constructed and pressure-tested in accordance with the requirements of Section IV Part HLW of the American Society of Mechanical Engineers Code, and factory fire-tested.

All models are National Board registered. Temperature and pressure gauge is standard. Direct Spark ignition device is standard. All heaters can be used either indoor or outdoors.

Ambient Temperature Rating of Heater Components

Electronic Ignition Heater* -32°F to + 175°F

*Requires 120 or 240VAC Single-Phase 60 Hertz Power Supply

Rated inputs are suitable for up to 2,000 feet elevation. The input will be reduced by approximately 4% for each 1,000 feet above 2,000 feet, as high elevation reduces gas and air density.

SECTION 3 - INSTALLATION INSTRUCTIONS

WARNING: This unit contains refractory ceramic fiber (RCF) insulation in the combustion chamber. RCF, as manufactured, does not contain respirable crystalline silica. However, following sustained exposure to very high temperatures (>2192°F), the RCF can transform into crystalline silica (cristabolite). The International Agency for Research on Cancer (IARC) has classified the inhalation of crystalline silica (cristabolite) as carcinogenic to humans.

When removing the burner or heat exchanger, take precautions to avoid creating airborne dust and avoid inhaling airborne fibers. When cleaning spills, use wet sweeping or High Efficiency Particulate Air (HEPA) filtered vacuum to minimize airborne dust. Use feasible engineering controls such as local exhaust ventilation or dust collecting systems to minimize airborne dust. Wear appropriate personal protective equipment including gloves, safety glasses with side shields, and appropriate NIOSH certified respiratory protection, to avoid inhalation of airborne dust and airborne fiber particles.

IMPORTANT NOTICE

These instructions are intended only for the use by qualified personnel, specifically trained and experienced in the installation of this type of heating equipment and related system components. Installation and service personnel may be required by some states to be licensed. If your state is such, be sure your contractor bears the appropriate license. Persons not qualified shall not attempt to fix this equipment nor attempt repairs according to these instructions.

WARNING: *Improper installation, adjustment, alteration, service or maintenance may damage the equipment, create a hazard resulting in asphyxiation, explosion or fire, and will void the warranty.*

CODE REQUIREMENTS

NOTE: *The heater should not be located in an area where possible water leakage will result in damage to the area adjacent to the heater or to the structure. When such locations cannot be avoided, it is recommended that a suitable drain pan, with adequate drainage, be installed under the heater. The pan must not restrict combustion air flow.*

Installation must be in accordance with local codes, or, in the absence of local codes, with the latest edition of the National Fuel Gas Code, ANSI Z223.1/NFPA54 and National Electrical Code, ANSI/NFPA 70, and for Canada, the latest edition of CAN/CSA-B149 Installation Codes, and Canadian Electrical Code, CSA C22.1 Part 1 and Part 2.

CLEARANCES

ALL HEATERS

For clearances from combustible surfaces, see the chart below.

CLEARANCE FROM COMBUSTIBLE CONSTRUCTION	
INDOOR INSTALLATIONS:	
Top* - 30"	Back - 1"
Front - Alcove (Open)	Right Side - 1"
Vent - 1"	Left Side - 1"
Floor** - 0"	
OUTDOOR INSTALLATION - TOP EXHAUST	
Top* - Unobstructed (<i>Outdoor Stack</i>)	
Floor - 0"	Right Side - 8"
Back - 6"	Left Side - 8"
OUTDOOR INSTALLATION - REAR EXHAUST	
Top* - Unobstructed	
Floor - 0"	Right Side - 8"
Back - 12"	Left Side - 8"

*Clearance from top of vent terminal when using top vent. When using the rear vent, top clearance is reduced to 1"..

**Do not install on carpeting.

Table B: Combustible Clearances

When installed according to the listed minimum clearances from combustible construction, the pool heater can still be serviced without removing permanent construction around the heater.

However, **for ease of servicing, Raypak recommends a clearance of at least 24" in the front, at least 18" on the water connection side and 12" on top.** This will enable the heater to be serviced in its installed location, that is, without movement or removal of the heater.

Clearances to combustible surfaces can be reduced per Table 10.2.3 of the National Fuel Gas Code.

The heater must be installed in a manner that will enable the heater to be serviced without removing any structure around the heater.

FLOORING: This heater can be installed on combustible flooring. Do not install on carpet.

OUTDOOR HEATER INSTALLATION

These heaters are design-certified for outdoor installation, when equipped with the approved tops designated for outdoor use.

WARNING: The heater shall not be located in an area where water sprinklers, or other devices, may cause water to spray through the cabinet louvers and into the heater. This could cause internal rusting or damage electrical components, and void the warranty.

WARNING: Do not install within 3 feet of a heat pump or an outdoor condensing unit. Strong air intake from this type of equipment can disturb the combustion process and cause damage or personal injury.

Heaters must not be installed under an overhang of less than three 3 ft from the top of the heater. Three sides must be open in the area under the overhang. Roof water drainage must be diverted away from the heaters installed under overhangs with the use of gutters.

For U.S. installations, the point from where the flue products exit the heater must be a minimum of 4 ft below, 4 ft horizontally from, or 1 ft above any door, window or gravity inlet into any building. The top surface of the heater shall be at least 3 ft above any forced air inlet, or intake ducts located within 10 ft horizontally.

For installations in Canada, pool heaters shall not be installed with the top of the vent assembly within 10 ft below, or to either side, of any opening into the building. Refer to the latest revisions of CAN/CSA-B149.

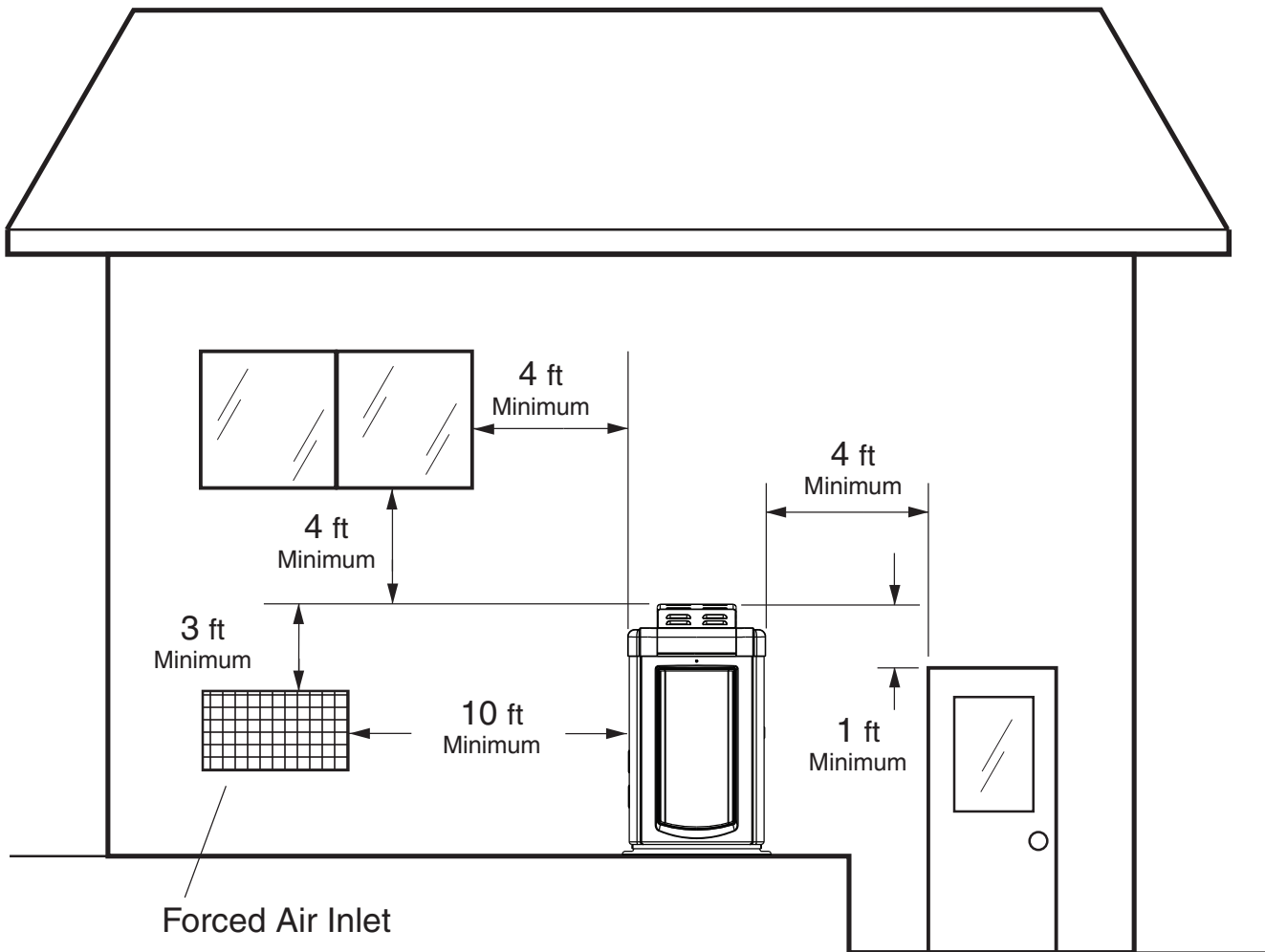

Fig. 5: Outdoor Installation Clearances

For installations in Florida and Texas, that must comply with the Florida or Texas Building Code, follow the directions on page 13 for the installation of hurricane tie-down method for all models.

ULTIMATE WIND SPEED = 170 MPH, 3 SECOND GUST
 NOMINAL WIND SPEED = 132 MPH, 3 SECOND GUST (ASD)
 EXPOSURE = D

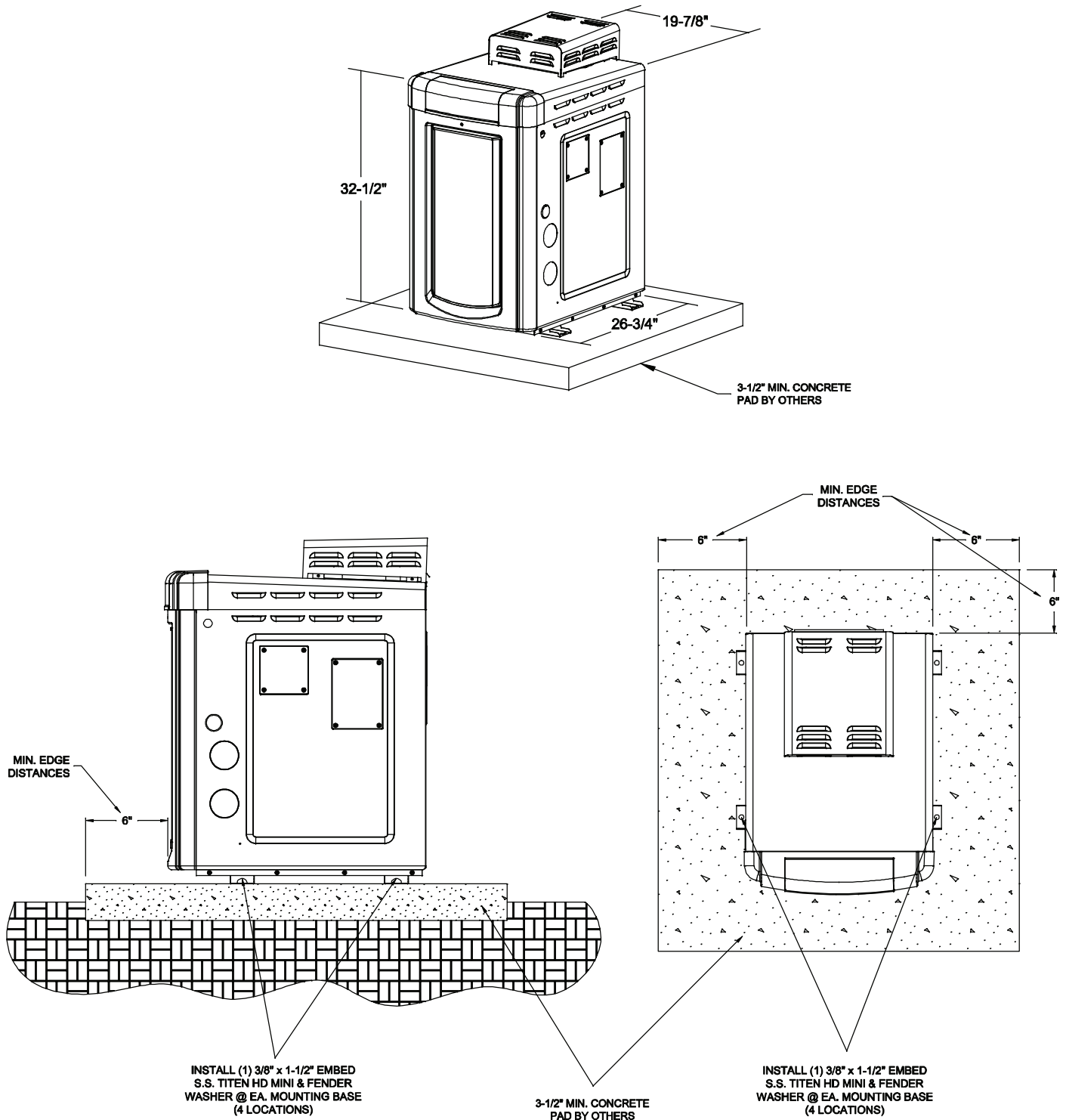

Fig. 6: Florida Building Code 2010 Tie-Down Method

INDOOR HEATER INSTALLATION

Locate the heater as close as is practical to a chimney or gas vent. **The heater must always be vented to the outside.** See the Venting section (beginning on page 17) for details. Minimum allowable clearance is shown on the nameplate, and in the “Clearances” section on page 11. Adequate combustion and ventilation air must be provided. See page 16 for details.

SPECIFICATIONS AND DIMENSIONS

ELECTRICAL REQUIREMENTS:
120V/1ph/60Hz 6A
240V/1ph/60Hz 3A

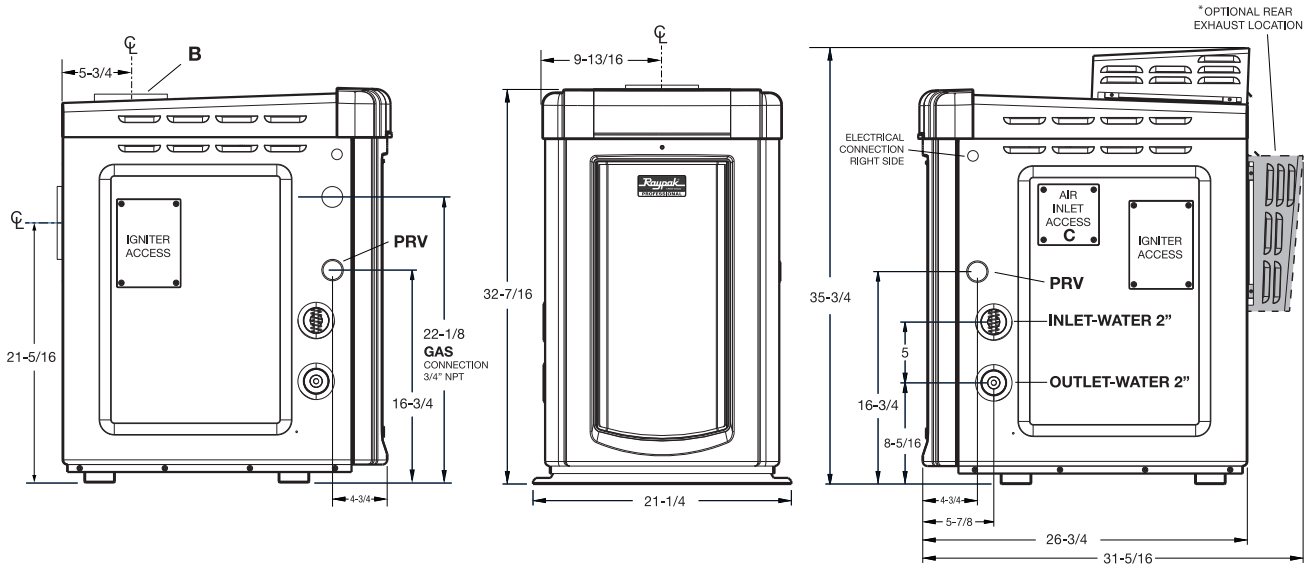

Heater Model	MBTU Input	Dimensions (in.)				Shipping Weight (lbs) w/ Stackless Top
		Flue Diameter (B)	Air Inlet (C)	Minimum Flow (gpm)	Maximum Flow (gpm)	
BR-259B	250.0	6"	4"	25	125	193
BR-409B	399.0	6"	4"	40	125	205

* Rear vent addon option 016256 required for rear exhaust location.

Fig. 7: Unit Dimensions

Notes:

- The model number prefix indicates: (B=Bronze header), (R=Raypak) Model number suffix indicates: pilot type (E = digital) and fuel type (P = propane, N = natural gas) fin tubing (X=Cupro-Nickel, C= Copper). Example: Model number BR-409B-EN-X indicates a unit with digital (IID) ignition using natural gas with bronze headers and cupro-nickel tubes.
- Ratings are for natural gas and elevations up to 2,000 feet above sea level. For elevations over 2,000 feet, consult the factory.
- Flue gases must be properly vented with CAT I vertical venting or CAT III horizontal venting. Non-metallic venting not acceptable. Inlet air can be ducted with 4" metal or PVC pipe. See the venting section of this manual for complete venting details.

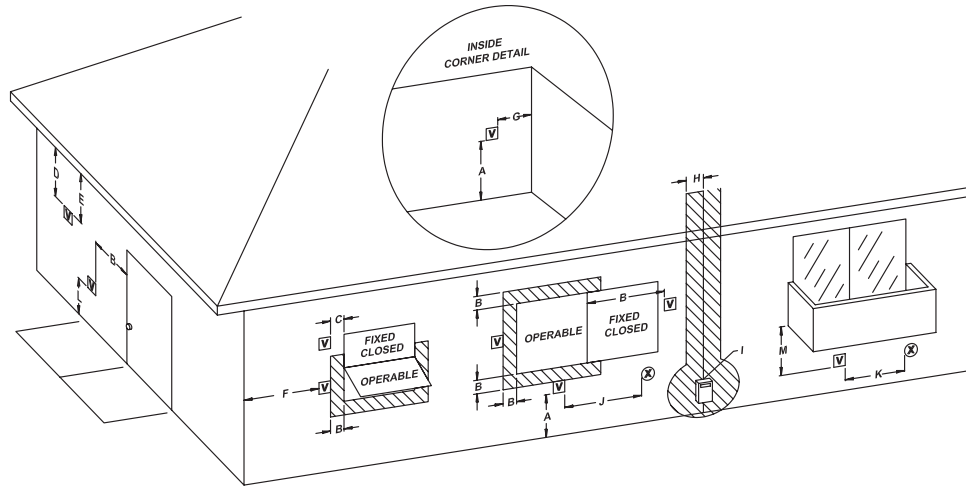

Minimum Clearances from Vent/Air Inlet Terminations – Indoor and Outdoor Installations

		U.S. Installations¹	Canadian Installations²
A	Clearance above grade, veranda, porch, deck, or balcony	1 ft (30 cm)	1 ft (30 cm)
B	Clearance to window or door that may be opened	4 ft (1.2m) below or to side of opening; 1 foot (30 cm) above opening	3 ft (91 cm)
C	Clearance to permanently closed window	*	*
D	Vertical clearance to ventilated soffit located above the terminal within a horizontal distance of 2 ft (61cm) from the centerline of the terminal	5 ft (1.5m)	*
E	Clearance to unventilated soffit	*	*
F	Clearance to outside corner	*	*
G	Clearance to inside corner	6 ft (1.83m)	*
H	Clearance to each side of center line extended above meter/regulator assembly	*	3 ft (91 cm) within a height 15 ft above the meter/regulator assembly
I	Clearance to service regulator vent outlet	*	3 ft (91cm)
J	Clearance to non-mechanical air supply inlet to building or the combustion air inlet to any other appliance	4 ft (1.2m) below or to side of opening; 1 ft (30 cm) above opening	3 ft (91 cm)
K	Clearance to mechanical air supply inlet	3 ft (91 cm) above if within 10 ft (3m) horizontally	6 ft (1.83m)
L	Clearance above paved sidewalk or paved driveway located on public property	7 ft (2.13m)	7 ft (2.13m) t
M	Clearance under veranda, porch, deck or balcony	*	12 in. (30 cm) TT

¹ In accordance with the current ANSI Z223.1/NFPA 54 National Fuel Gas Code

² In accordance with the current CAN/CSA-B149 Installation Codes

t Vent terminal shall not terminate directly above sidewalk or paved driveway located between 2 single family dwellings that serves both dwellings

TT Permitted only if veranda, porch, deck, or balcony is fully open on a minimum of two sides beneath the floor and top of terminal and underside of veranda, porch, deck or balcony is greater than 1 ft (30cm)

* Clearances in accordance with local installation codes and the requirements of the gas supplier

Fig. 8: Vent/Air Inlet Termination Clearances

COMBUSTION AND VENTILATION AIR (Indoor Units Only)

The heater must have both combustion and ventilation air. Minimum requirements for net free air supply openings are one opening that is 12 inches from the ceiling for ventilation, and one opening that is 12 inches from the floor for combustion air as outlined in the latest edition of the National Fuel Gas Code, ANSI Z223.1 (Canada-CAN/CSA-B149) and any local codes that may have jurisdiction.

A. All Air From Inside The Building:

Each opening shall have a minimum net free area as noted:

Model	Square Inches
259B	250
409B	399

Table C-1: Combustible Air Opening Size

B. All Air From Outdoors:

When air is supplied directly from outside the building, each opening shall have a minimum net free area as noted:

Model	Unrestricted Opening (sq. in.)	Typical Screened <i>or</i> Louvered Opening (sq. in.)	Typical Screened <i>and</i> Louvered Opening (sq. in.)
259B	63	95	126
409B	100	150	200

CAUTION: Combustion air must not be contaminated by corrosive chemical fumes which can damage the heater and void the warranty.

Table C-2: Combustible Air Opening Size

Direct Vent and Ducted Combustion Air Systems

If outside air is drawn through the intake pipe directly to the unit for combustion:

1. Connect combustion air to the heater by removing the screen on the air intake port, and sliding the PVC adapter to the shoulder. Glue or attach screws to fasten. The existing screen is used at the intake end of the duct. Install the combustion air duct in accordance with page 21 (horizontal) or page 22 (vertical) of this manual.
2. Provide adequate ventilation of the space occupied by the heater(s) by an opening(s) for ventilation air at the highest practical point communicating with the outdoors.
 - a) In the US, the total cross-sectional area shall be at least 1 in.² of free area per 20,000 BTUH (111 mm² per kW) of total input rating of all equipment in the room when the opening is communicating directly with the outdoors or through vertical duct(s). The total cross-sectional area shall be at least 1 in.² of free area per 10,000 BTUH (222 mm² per kW) of total input rating of all equipment in the room when the opening is communicating with the outdoors through horizontal duct(s).
 - b) In Canada, there shall be permanent air supply opening(s) having a total cross-sectional area of not less than 1 in.² of free area per 30,000 BTUH (70 mm² per kW) of the total rated input. The location of the opening(s) shall not interfere with the intended purpose of the opening(s) for the ventilation air.
3. In cold climates, and to mitigate potential freeze-up, Raypak highly recommends the installation of a motorized sealed damper to prevent the circulation of cold air through the heater during the non-operating hours.

VENTING

CAUTION: Proper installation of flue venting is critical for the safe and efficient operation of the heater.

General

Appliance Categories

Heaters are divided into four categories based on the pressure produced in the exhaust and the likelihood of condensate production in the vent.

Category I – A heater which operates with a non-positive vent static pressure and with a vent gas temperature that avoids excessive condensate production in the vent.

Category II – A heater which operates with a non-positive vent static pressure and with a vent gas temperature that may cause excessive condensate production in the vent.

Category III – A heater which operates with a positive vent pressure and with a vent gas temperature that avoids excessive condensate production in the vent.

Category IV – A heater which operates with a positive vent pressure and with a vent gas temperature that may cause excessive condensate production in the vent.

See the table below for appliance category requirements.

NOTE: For additional information on appliance categorization, see appropriate ANSI Z21 Standard and the NFGC (U.S.), or B149 (Canada), or applicable provisions of local building codes.

WARNING: Contact the manufacturer of the vent material if there is any question about the appliance categorization and suitability of a vent material for application on a Category III or IV vent system. Using improper venting materials can result in personal injury, death or property damage.

Combustion Air Supply	Exhaust Configuration	Heater Venting Category	Certified Materials	Combustion Air Inlet Materials
From Inside Building	Vertical Venting	I Fan	B-Vent Equivalent	
	Horizontal Through-the-Wall Venting	III	UL 1738 Metallic Vent (such as AL29-4C)	
From Outside Building (Direct Vent or Ducted Combustion Air)	Vertical Venting with Ducted Combustion Air	I Fan	B-Vent Equivalent	Galvanized Steel PVC ABS CPVC
	Vertical Direct Vent	III	UL 1738 Metallic Vent (such as AL29-4C)	
	Horizontal Direct Vent	III	UL 1738 Metallic Vent (such as AL29-4C)	

Table D: Venting Category Requirements

Support of Vent Stack

The weight of the vent stack or chimney must not rest on the heater vent connection. Support must be provided in compliance with applicable codes. The vent should also be installed to maintain proper clearances from combustible materials. Use insulated vent pipe spacers where the vent passes through combustible roofs and walls.

Vent Terminal Location

NOTE: During winter months check the vent cap and make sure no blockage occurs from build-up of snow or ice.

1. Condensate can freeze on the vent cap. Frozen condensate on the vent cap can result in a blocked flue condition.
2. Give special attention to the location of the vent termination to avoid possibility of property damage or personal injury.
3. Gases may form a white vapor plume in winter. The plume could obstruct a window view if the termination is installed near windows.
4. Prevailing winds, in combination with below-freezing temperatures, can cause freezing of condensate and water/ice build-up on buildings, plants or roofs.
5. The bottom of the vent terminal and the air intake shall be located at least 12 in. above grade, including normal snow line.
6. Un-insulated single-wall metal vent pipe shall not be used outdoors in cold climates for venting gas-fired equipment.
7. Through-the-wall vents for Category II and IV appliances and non-categorized condensing appliances shall not terminate over public walkways or over an area where condensate or vapor could create a nuisance or hazard or could be detrimental to the operation of regulators, relief valves, or other equipment. Where local experience indicates that condensate is a problem with Category I and III appliances, this provision shall also apply.
8. Locate and guard vent termination to prevent accidental contact by people or pets.
9. DO NOT terminate vent in window well, stairwell, alcove, courtyard or other recessed area.

10. DO NOT terminate above any door, window, or gravity air intake. Condensate can freeze, causing ice formations.
11. Locate or guard vent to prevent condensate from damaging exterior finishes. Use a rust-resistant sheet metal backing plate against brick or masonry surfaces.
12. DO NOT extend exposed vent pipe outside of building beyond the minimum distance required for the vent termination. Condensate could freeze and block the vent pipe.

U.S. Installations

Refer to the latest edition of the National Fuel Gas Code.

Vent termination requirements are as follows:

1. Vent must terminate at least 4 ft below, 4 ft horizontally from or 1 ft above any door, window or gravity air inlet to the building.
2. The vent must not be less than 7 ft above grade when located adjacent to public walkways.
3. Terminate vent at least 3 ft above any forced air inlet located within 10 ft.
4. Vent must terminate at least 4 ft horizontally, and in no case above or below unless 4 ft horizontal distance is maintained, from electric meters, gas meters, regulators, and relief equipment.
5. Terminate vent at least 6 ft away from adjacent walls.
6. DO NOT terminate vent closer than 5 ft below roof overhang.
7. The vent terminal requires a 12 in. vent terminal clearance from the wall.
8. Terminate vent at least 1 ft above grade, including normal snow line.
9. Multiple direct vent installations require a 4 ft clearance between the ends of vent caps located on the same horizontal plane.

WARNING: The Commonwealth of Massachusetts requires that sidewall vented heaters, installed in every dwelling, building or structure used in whole or in part for residential purposes, be installed using special provisions as outlined on page 47 of this manual.

Canadian Installations

Refer to latest edition of the B149 Installation code.

A vent shall not terminate:

1. Directly above a paved sidewalk or driveway which is located between two single-family dwellings and serves both dwellings.
2. Less than 7 ft (2.13 m) above a paved sidewalk or paved driveway located on public property.
3. Within 6 ft (1.8 m) of a mechanical air supply inlet to any building.
4. Above a meter/regulator assembly within 3 ft (915 mm) horizontally of the vertical centre-line of the regulator.
5. Within 3 ft (0.9 m) of any gas service regulator vent outlet.
6. Less than 1 ft (305 mm) above grade level.
7. Within the 3 ft (915 mm) of a window or door which can be opened in any building, any non-mechanical air supply inlet to any building or the combustion air inlet of any other appliance.
8. Underneath a verandah, porch or deck, unless the verandah, porch or deck is fully open on a minimum of two sides beneath the floor, and the distance between the top of the vent termination and the underside of the verandah, porch or deck is greater than 1 ft (305 mm).

Venting Installation Tips

Support piping:

- horizontal runs—at least every 5 ft
- vertical runs—use braces
- under or near elbows

WARNING: Examine the venting system at least once a year. Check all joints and vent pipe connections for tightness, corrosion or deterioration.

Venting Configurations

For heaters connected to gas vents or chimneys, vent installations shall be in accordance with the NFGC (U.S.), or B149 (Canada), or applicable provisions of local building codes.

Natural Draft Vertical Venting (Category I) Fan-Assisted

Installation

Natural draft venting uses the natural tendency of the heated flue gases to rise, until they are expelled from the top of the flue. The negative draft must be within the range of -.01 to -.08 in. WC as measured 12 in. above the appliance flue outlet to ensure proper operation. Vent material must be listed by a nationally recognized test agency.

Double-wall Type B vent must be used to promote draft and to minimize condensation in the vent.

No drafthood is required or offered. A single-acting barometric damper is required if the height exceeds 25 feet. Consult the factory for additional information.

Model No.	Certified Vent Material	Vent Size (in.)	Vertical Vent Height ¹ (ft)		Combustion Air Intake Pipe Material**	Air Inlet Max. Length* (ft) 4" Ø
			Min.	Max.		
259B	Category I (Type B Equivalent) Fan-Assisted	6	5	25	Galvanized Steel, PVC, ABS, CPVC	80
409B						

¹ Vent lengths are based on a lateral length of 2 ft. Refer to the latest edition of the NFGC for further details. When vertical height exceeds 25 ft, consult factory prior to installation.

* Subtract 10 ft per elbow. Max. 4 elbows.

** Schedule 40 in PVC or CPVC.

Table E: Category I Vertical Venting

The connection from the appliance vent to the stack must be as direct as possible. The horizontal breaching of a vent must have an upward slope of not less than 1/4 inch per linear foot from the heater to the vent terminal. The horizontal portions of the vent shall also be supported for the design and weight of the material employed to maintain clearances and to prevent physical damage or separation of joints.

Termination

The vent terminal should be vertical and should terminate outside the building at least 2 ft above the highest point of the roof that is within 8 ft. The vent cap should have a minimum clearance of 4 ft horizontally from and in no case above or below (unless a 4 ft horizontal distance is maintained) electric meters, gas meters, regulators and relief equipment. The distance of the vent terminal from adjacent public walkways, adjacent buildings, open windows and building openings must be consistent with the NFGC (U.S.) or B149 (Canada). Gas vents supported only by flashing and extended above the roof more than 5 ft should be securely guyed or braced to withstand snow and wind loads.

CAUTION: A listed vent cap terminal adequately sized, must be used to evacuate the flue products from the building.

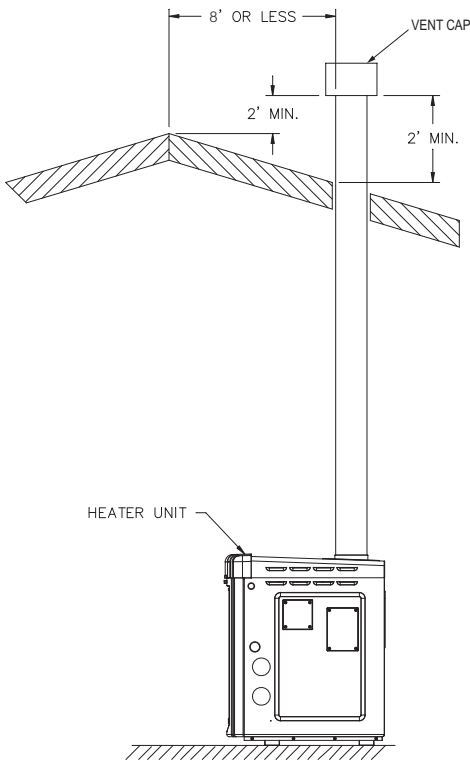

NOTE: For common venting of two or more heaters, contact the factory.

Fig. 9: Vertical Venting

Horizontal Through-the-Wall Venting (Category III)

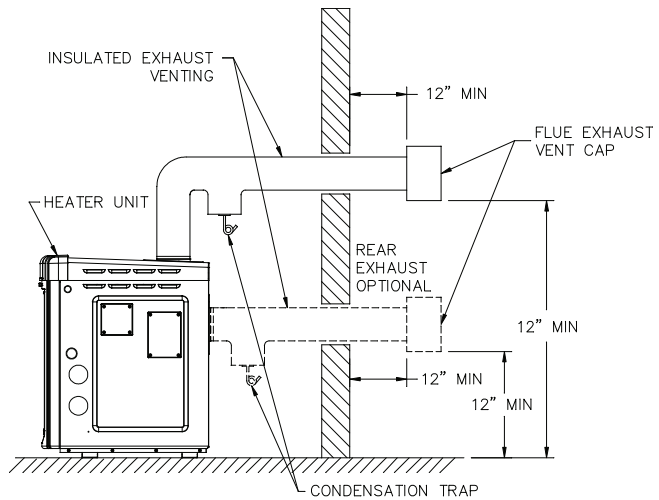

Fig 10: Horizontal Through-the-Wall Venting

CAUTION: This venting system requires the installation of a condensate drain in the vent piping per the vent manufacturer's instructions. Failure to install a condensate drain in the venting system will void all warranties on this heater.

Installation

These installations utilize the heater's internal blower to vent the combustion products to the outdoors. Combustion air is taken from inside the room and the vent is installed horizontally through the wall to the outdoors. Adequate combustion and ventilation air must be supplied to the equipment room in accordance with the NFGC (U.S.) or B149 (Canada).

The total length of the horizontal through-the-wall flue system should not exceed 80 equivalent ft in length. If horizontal run exceeds 80 equivalent ft, an appropriately sized variable-speed extractor must be used. Each elbow used is equal to 10 ft of straight pipe. This will allow installation in one of the five following arrangements:

- 80' of straight flue pipe
- 70' of straight flue pipe and one elbow
- 60' of straight flue pipe and two elbows
- 50' of straight flue pipe and three elbows
- 40' of straight flue pipe and four elbows

The vent cap is not considered in the overall length of the venting system.

Model No.	Vent Size (in.)	Maximum Horizontal Vent Length (ft)*
409B	6"	80
259B		
409B	5"	40
259B		80
259B	4"	40

* Subtract 10 ft. per elbow, maximum 4 elbows

Table F: Horizontal Venting Size

The vent must be installed to prevent flue gas leakage. Care must be taken during assembly to ensure that all joints are sealed properly and are airtight. The vent must be installed to prevent the potential accumulation of condensate in the vent pipes. It is recommended that the vent be insulated. Insulation is required for installations in cold environments (i.e. below 40°F or 4°C). It is required that:

1. The vent must be installed with a condensate drain located in proximity to the heater as directed by the vent manufacturer.
2. The vent must be installed with a slight upward slope of not less than 1/4 inch per foot of horizontal run to the vent terminal.

Termination

The direct vent cap MUST be mounted on the exterior of the building. The direct vent cap cannot be installed in a well or below grade. The direct vent cap must be installed at least 1 ft above ground level and above normal snow levels. The Raypak-approved stainless steel direct vent cap must be used. The vent terminal must be located NO CLOSER than 12" off the wall.

WARNING: No substitutions of flue pipe or vent cap material are allowed. Such substitutions would jeopardize the safety and health of inhabitants.

Direct Vent - Horizontal Through-the-Wall

Installation

These installations utilize the heater's internal blower to draw combustion air from outdoors and vent combustion products to the outdoors.

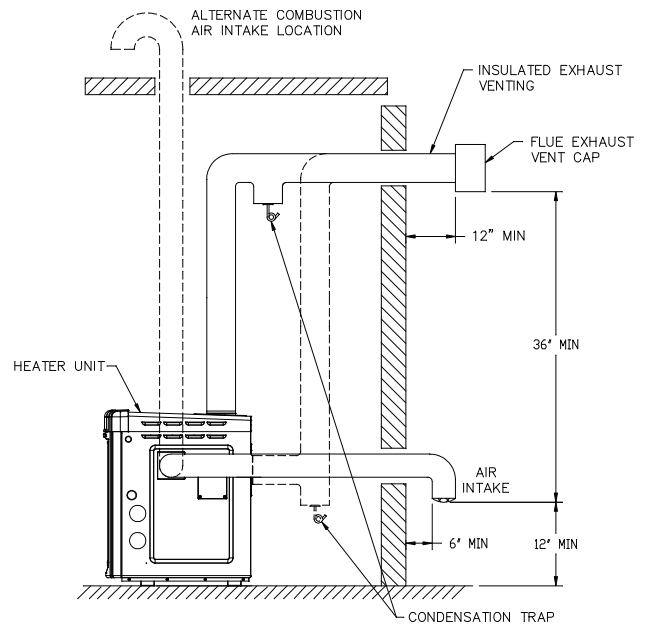

Fig. 11: Horizontal Through-the-Wall Direct Venting

The total length of the through-the-wall flue cannot exceed 80 equivalent ft in length for the flue outlet. Each elbow used is equal to 10 ft of straight pipe. This will allow installation in one of the five following arrangements:

- 80' of straight flue pipe
- 70' of straight flue pipe and one elbow
- 60' of straight flue pipe and two elbows
- 50' of straight pipe and three elbows
- 40' of straight pipe and four elbows

The flue direct vent cap is not considered in the overall length of the venting system.

Care must be taken during assembly that all joints are sealed properly and are airtight.

The vent must be installed to prevent the potential accumulation of condensate in the vent pipes. It is recommended that the vent be insulated. Insulation is required for installations in cold environments (i.e. below 40°F or 4°C).

For installations in extremely cold climate, it is required that:

1. The vent must be installed with a slight upward slope of not more than 1/4 inch per foot of horizontal run to the vent terminal. An approved condensate trap must be installed per applicable codes.
2. The intake vent must be insulated through the length of the horizontal run.

Termination

The flue direct vent cap **MUST** be mounted on the exterior of the building. The direct vent cap cannot be installed in a well or below grade. The direct vent cap must be installed at least 1 ft above ground level and above normal snow levels.

The direct vent cap **MUST NOT** be installed with any combustion air inlet directly above a direct vent cap. This vertical spacing would allow the flue products from the direct vent cap to be pulled into the combustion air intake installed above.

This type of installation can cause non-warrantable problems with components and poor operation of the heater due to the recirculation of flue products. Multiple direct vent caps should be installed in the same horizontal plane with a 4 ft clearance from the side of one vent cap to the side of the adjacent vent cap(s).

Combustion air supplied from outdoors must be free of particulate and chemical contaminants. To avoid a blocked flue condition, keep the vent cap clear of snow, ice, leaves, debris, etc.

WARNING: No substitutions of flue pipe or vent cap material are allowed. Such substitutions would jeopardize the safety and health of inhabitants.

CAUTION: Condensate is acidic and highly corrosive.

The stainless steel flue direct vent cap **MUST** be furnished by the heater manufacturer in accordance with its listing (sales order option D-15).

Use only the special gas vent pipes listed for use with Category III gas burning heaters, such as the AL29-4C stainless steel vents offered by Selkirk Inc. (1-800-992-VENT or 1-800-992-8368 in the US, or 1-888-SEL-KIRK or 1-888-735-5475 in Canada), Protech System, Inc. (800-766-3473), Z-Flex (800-654-5600) or American Metal Products (800-423-4270). Pipe joints must be positively sealed. Follow the vent manufacturer's installation instructions carefully.

Direct Vent—Vertical

Installation

These installations utilize the heater-mounted blower to draw combustion air from outdoors and force the heated flue products through the vent pipe under positive pressure. The vent material must be in accordance with the above instructions for vent materials. Vent material must be listed by a nationally recognized test agency.

The connection from the appliance flue to the stack must be as direct as possible and should be the same size or larger than the vent outlet.

See pages 16-20 for Category I Venting with Ducted Air guidelines.

It is recommended that the intake vent be insulated in colder climates.

Termination

The flue terminal should be vertical and should terminate outside the building at least 2 ft above the highest point of the roof within 10 ft. The vent cap should have a minimum clearance of 4 ft horizontally from and in no case above or below (unless a 4 ft horizontal distance is maintained) electric meters, gas meters, regulators and relief equipment. The distance of the vent terminal from adjacent public walkways, adjacent buildings, open windows and building openings must be consistent with the NFGC (U.S.) or B149 (Canada).

WARNING: No substitutions of vent pipe or vent cap material are allowed. Such substitutions would jeopardize the safety and health of inhabitants.

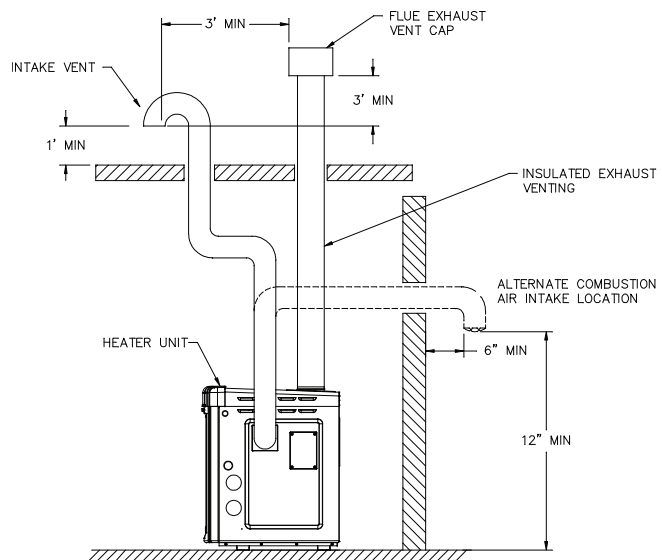

Fig. 12: Direct Vent - Vertical

Model No.	Certified Vent Material	Vent Size (in.)	Maximum Horizontal Vent Length (ft)**	Combustion Air Intake Pipe Material	Air Intake Max. Length** (ft) 4" Ø
409B	Category III	6	80	Galvanized Steel, PVC, ABS, CPVC	80
259B					
409B		5	40		
259B					
259B					

** Subtract 10 ft per elbow. Max. 4 elbows.

Table G: Category III Horizontal Vent & Horizontal Direct Vent

Vent pipes supported only by flashing and extended above the roof more than 5 ft should be securely guyed or braced to withstand snow and wind loads.

The air inlet opening MUST be installed 1 ft above the roof line or above normal snow levels that might obstruct combustion air flow. This dimension is critical to the correct operation of the heater and venting system and reduces the chance of blockage from snow. The vent cap must have a minimum 3 ft vertical clearance from the air inlet opening.

Use only the special gas vent pipes listed for use with Category III gas burning heaters, such as the AL29-4C stainless steel vents offered by Selkirk Inc. (1-800-992-VENT or 1-800-992-8368 in the US, or 1-888-SEL-KIRK or 1-888-735-5475 in Canada), Protech System, Inc. (800-766-3473), Z-Flex (800-654-5600) or American Metal Products (800-423-4270). Pipe joints must be positively sealed. Follow the vent manufacturer's installation instructions carefully.

Outdoor Installation

The stackless top provided with the heater is the standard venting method for outdoor installations. The stackless top may be used in its standard top-mounted configuration or moved to the rear of the heater for a rear-exhaust configuration. See the diagram below. A few reasons why the rear stackless top may be considered are:

- a) It reduces the chance of water infiltration, especially in snowy areas.
- b) It relieves lot line restrictions.
- c) It is easier to service the heater.

Care must be taken when locating the heater outdoors, because the flue gases discharged from the vent cap can condense as they leave the cap. Improper location can result in damage to adjacent structures or building finish. For maximum efficiency and safety, the following precautions must be observed:

1. Periodically check venting system. The heater's venting areas must never be obstructed in any way and minimum clearances must be observed to prevent restriction of combustion and ventilation air. Keep area clear and free of combustible and flammable materials.
2. Do not locate adjacent to any window, door, walkway, or gravity air intake. The vent must be located a minimum of 4 ft horizontally from such areas.
3. Install above grade level and above normal snow levels.
4. Vent terminal must be at least 3 ft above any forced air inlet located within 10 ft.
5. Adjacent brick or masonry surfaces must be protected with a rust-resistant sheet metal plate.

NOTE: Condensate can freeze on the vent cap. Frozen condensate on the vent cap can result in a blocked flue condition.

GAS SUPPLY CONNECTIONS

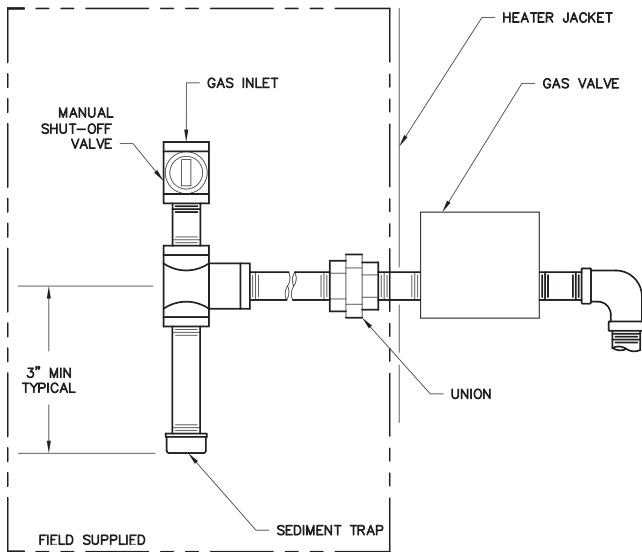

Fig. 13: Gas Connection

Gas piping must have a sediment trap ahead of the heater gas controls, and a manual shut-off valve located outside the heater jacket. All gas piping should be tested after installation in accordance with local codes.

CAUTION: The heater and its manual shut-off valve must be disconnected from the gas supply during any pressure testing of that system at test pressures in excess of 1/2 psi (3.45 kPa). Dissipate test pressure in the gas supply line before reconnecting the heater and its manual shut off valve to gas supply line. **FAILURE TO FOLLOW THIS PROCEDURE MAY DAMAGE THE GAS VALVE. OVER-PRESSURIZED GAS VALVES ARE NOT COVERED BY WARRANTY.** The heater and its gas connections shall be leak tested before placing the appliance in operation. Use soapy water for leak test. **DO NOT** use open flame.

NOTE: Do not use Teflon tape on gas line pipe thread. A pipe compound rated for use with natural and propane gases is recommended. Apply sparingly only on male pipe ends, leaving the two end threads bare. A minimum of 4 in. WC and a maximum of 10.5 "WC

SUPPLY PRESSURES

upstream pressure under load and no-load conditions must be provided for natural gas. A minimum of 12 "WC and a maximum of 14 "WC are required for propane gas under load and no-load conditions, with no more than a 30% pressure drop between static pressure and full load.

The factory manifold pressure settings should be $-0.40" \pm 0.1"$ WC for either natural or propane gas.

GAS PRESSURE ADJUSTMENT LOCATIONS

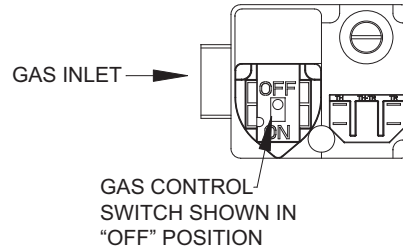

Fig. 14: Gas Valve

PIPE SIZING FOR GAS CONNECTIONS

Maximum Equivalent Pipe Length (ft)									
Natural Gas 1000 BTU/FT ³ 0.60 Specific Gravity @ 0.5 in. WC Pressure Drop									
Propane Gas 2500 BTU/FT ³ 1.53 Specific Gravity @ 0.5 in. WC Pressure Drop									
	Input	3/4"		1"		1-1/4"		1-1/2"	
Model	(KBTU)	N	P	N	P	N	P	N	P
259B	250.0	15	35	50	125	210	480	445	
409B	399.0	*	15	20	55	95	225	215	480

*A 3/4" gas line can be used for up to 5 ft maximum length from the gas valve in addition to the sediment trap.

Table H: Gas Pipe Size

HEAT EXCHANGER PRESSURE DROP TABLES

BRASS HEADER		
FLOW GPM	PRESSURE DROP (FT OF HEAD)	
	259B	409B
20		
25	4.4	
30	5.2	
35	5.3	
40	5.4	9.9
50	5.8	10.2
60	6.4	10.8
70	7.6	11.6
80	8.6	12.5
90	10.6	13.6
100	11.8	15.0
110	21.0	23.5
120	26.0	28.5
125	28.0	30.0

Table I: Heat Exchanger Pressure Drop

FLOW RATES

MODEL	PIPE SIZE	MIN. GPM	MAX. GPM*
259B	1-1/4"–1-1/2" - 2"	25	125
409B	1-1/4"–1-1/2" - 2"	40	125

*When flow rates exceed maximum GPM, an external auxiliary bypass valve is required. See external bypass valve section for details.

Table J: Flow Rates

INTERNAL AUTOMATIC BYPASS VALVE

A built-in automatic bypass valve is provided in the in/out header. The internal bypass valve automatically responds to changes in water flow in the piping system. Proper amount of water is maintained through the heater under varying flows dictated by the conditions of the pump and filter.

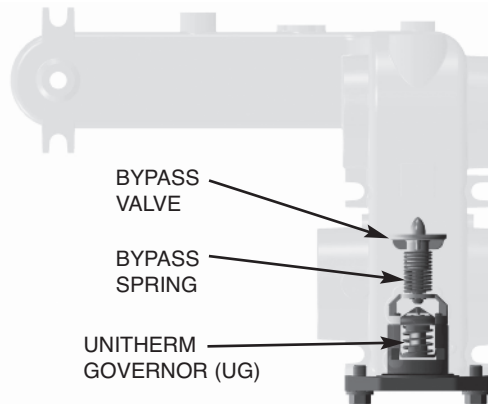

Fig. 15: Internal Bypass Valve

EXTERNAL AUXILIARY BYPASS VALVE (Where Required)

An auxiliary bypass valve should be used when flow rates exceed 125 GPM. Usually a high-performance pump size larger than two horsepower will exceed this flow rate. This valve is required to complement the function of the automatic bypass valve, particularly when starting the heater in winter or early spring when the spa or pool temperature is below 50°F. It also serves to eliminate needless pressure drop through the heater and accompanying reduction in the flow rate to the spa jets, etc.

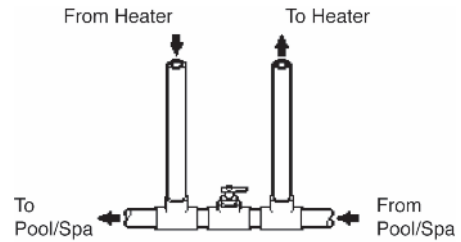

Fig. 16: Auxiliary Bypass Valve
(DO NOT USE GATE VALVE)

AUXILIARY BYPASS VALVE ADJUSTMENT

To set bypass: With clean filter, adjustment is made by feeling the inlet and outlet pipes at the heater. Outlet pipes should be slightly warmer than inlet and comfortable to the touch. If pipe is hot, close bypass; if cold, open bypass.

PRESSURE RELIEF VALVE INSTALLATION

To conform to local building codes, it may be necessary to install a 3/4" pressure relief valve, having a capacity at least equal to the BTUH output of the model. The maximum acceptable pressure relief valve setting is 125 psi.

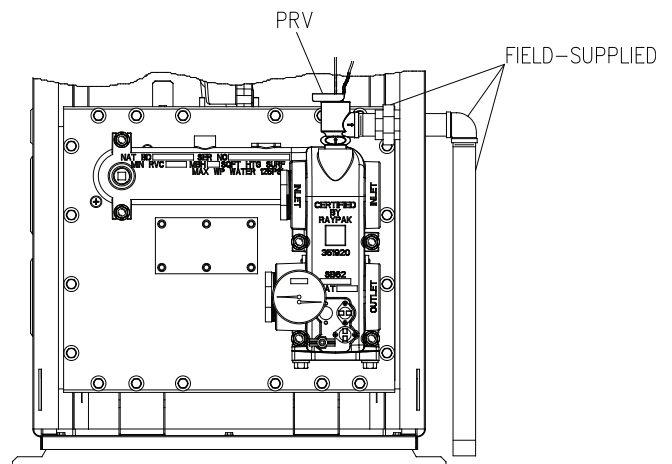

Fig. 17: Pressure Relief Valve

NOTE: To avoid water damage or scalding due to valve operation, drain pipe must be connected to valve outlet and run to a safe place of discharge. Drain pipe must be the same size as the valve discharge connection throughout its entire length and must pitch downward from the valve. No shut-off valve shall be installed between the relief valve and the drain line. Valve lever should be tripped at least once a year to ensure that waterways are clear.

TRANSFORMER WIRING

120 VAC WIRING

For 120 VAC input power to the unit, connect the pair of black wires to the “L1” or hot leg of the power supply. Connect the red/white wire and the white wire to the “Ret” or neutral leg of the power supply. Attach the wire nut to the red wire. **There should be no connection to the red wire for 120 VAC operation. The 120 VAC blower plug should be wire tied alongside the 240 VAC blower plug.**

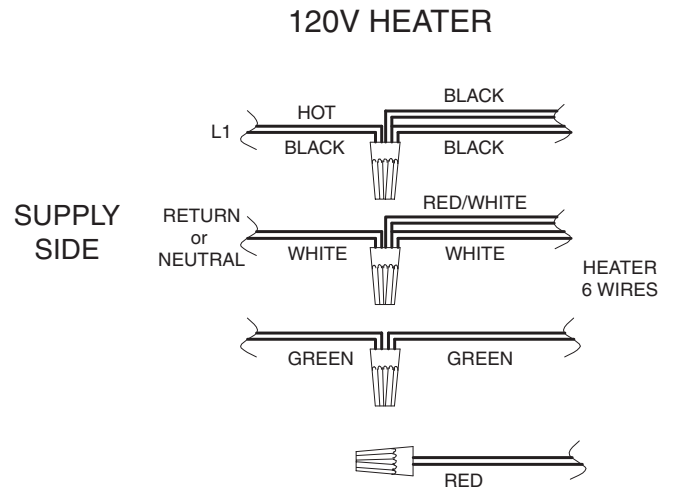

240 VAC WIRING

For 240 VAC input power to the unit, connect the pair of black wires to the “L1” or hot leg of the power supply. Connect the red/white wire and the red wire to the “L2” or second hot leg of the power supply. Attach the wire nut to the white wire. **There should be no connection to the white wire for 240 VAC operation.**

WARNING: DO NOT attempt to operate the heater with 208 VAC supply voltage or 50Hz supply frequency.

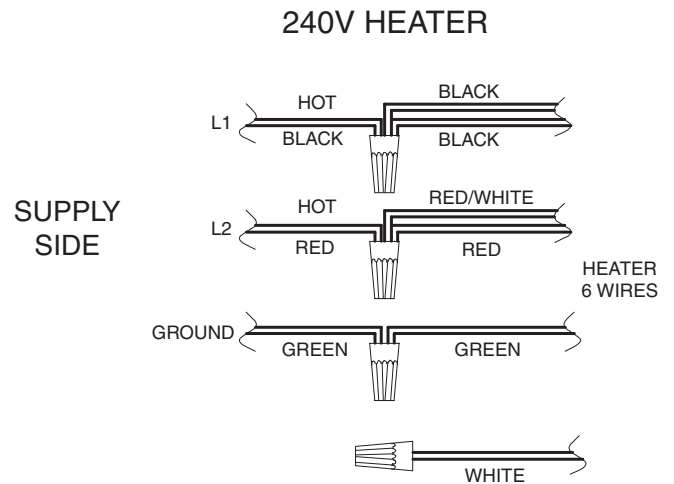

Fig. 19: Wiring Connections

The heater must be electrically grounded and bonded in accordance with local codes, or, in the absence of local codes, with the latest edition of the National Electrical Code, ANSI/NFPA 70. (Canada - Canadian Electrical Code, CSA C22.1, Part 1 and Part 2.)

NOTE: If the transformer’s primary side is wired for 120 VAC and 240 VAC is applied, damage to the transformer and PC board may result. Such damages are not covered under manufacturer’s limited warranty.

NOTE: Input power to the heater (120 or 240 VAC) can be supplied from the load (pump) side of time clock or directly from the GFCI power source. **It is required that full-time power be supplied to the heater from the GFCI power source, and that the heater be controlled by the fireman’s switch connection or using a two-wire or three-wire remote. See pages 38-40.** If using a switched GFCI power source, the heater post-purge function will be bypassed, adversely affecting heater operation and life.

OPTIONAL LEFT-HAND WIRING

If the standard right-hand electrical wiring is not accessible or convenient, wiring can be done from the left-hand side instead. Conversion is done using the following method:

1. Locate the plug on the left-hand side of the unit.
2. Remove plug and set aside.
3. Locate the junction box. Remove the screw holding the cover in place and set the cover aside.
4. Pull the bundle of heater wires back in from the right jacket panel.
5. Remove the grommet from right panel and replace with the plug from the left-hand side.
6. Route supply lines from the left side and through the provided loops under the control panel (see image).
7. See provided wiring tag for correct connection points.
8. Reinstall the junction box cover when completed.

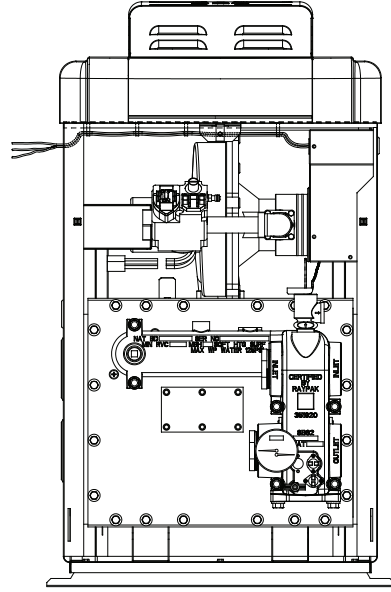

Fig. 20: Optional left-hand wiring

PLUMBING—WATER CONNECTIONS

The heater has standard right-hand plumbing connections, but can be converted to alternate configurations as shown below.

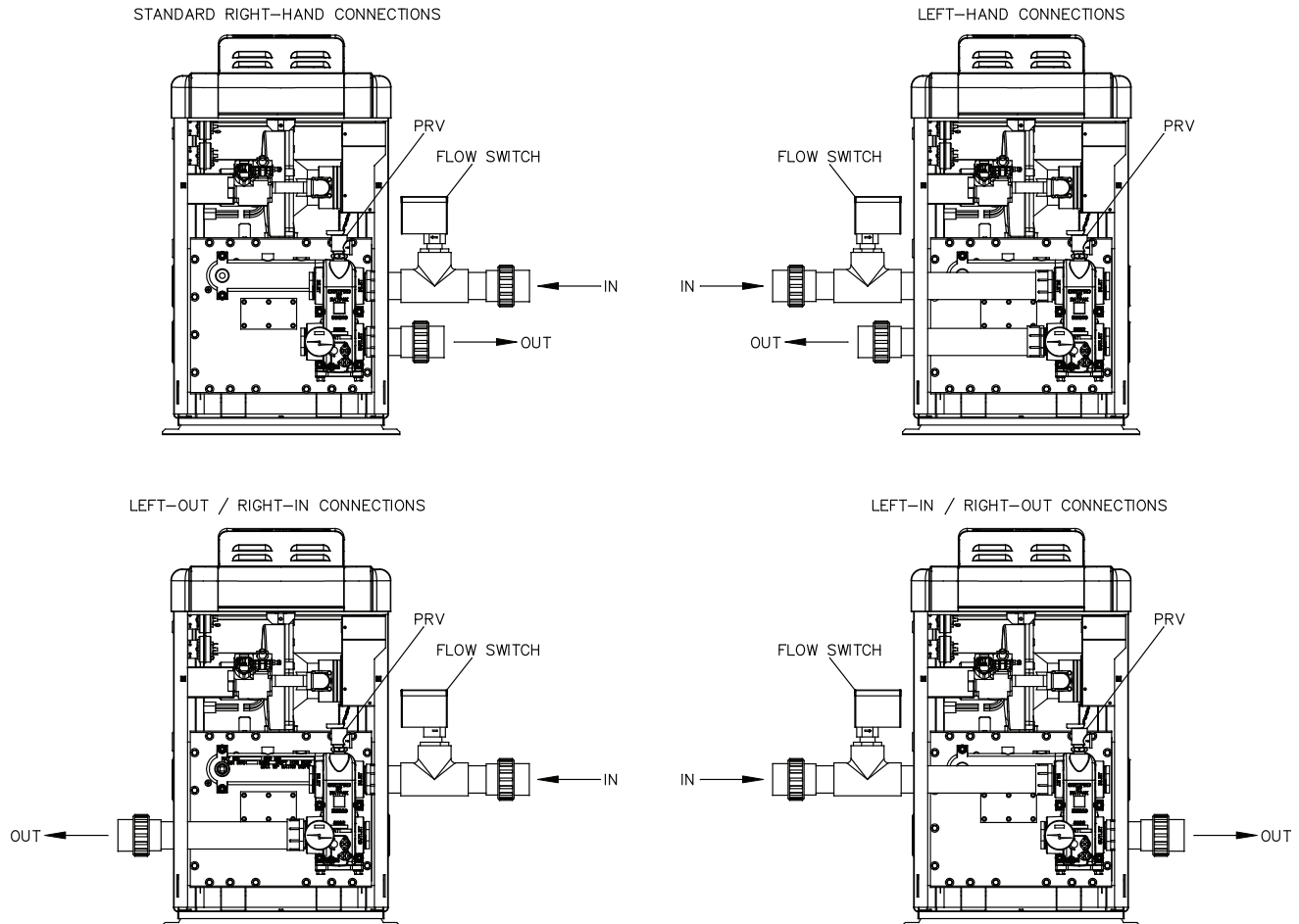

Fig. 21: Water Connection Configurations

The conversion is performed using the following procedures:

WARNING: Before performing any conversion steps, make sure that all electrical power to the heater has been turned OFF.

LEFT HAND PLUMBING

1. Rotate and remove the PRV and reducer bushing from In/Out Header.
2. Rotate and remove the T&P Gauge.
3. Remove cover from the Flow Switch and disconnect wiring.
4. Rotate and remove the Flow Switch from In/Out header.
5. Relocate the PRV and the reducer bushing to where the Flow Switch was located.
6. Tighten down the PRV and position the outlet toward the right jacket side.
7. Relocate the Flow Switch to where the PRV was located.
8. Tighten down the Flow Switch and position the arrow on the flow switch to the left jacket side.
9. Rewire the Flow Switch, one lead on C (common), the second on NO (normally open).
10. Place cover over the Flow Switch and tighten down the screw.
11. Re-install the T&P Gauge.
12. Remove the thermostat sensor from the Jaco fitting and set aside.
13. Remove both CPVC Ring Nuts and Plugs.
14. Relocate and tighten both CPVC Ring Nut and Plugs to the right side of the In/Out Header. Note: the Jaco fitting plug must be located on the Inlet side.
15. Reroute and install the thermostat sensor to the right side of the In/Out Header.

LEFT INLET / RIGHT OUTLET PLUMBING

1. Remove the thermostat sensor from Jaco fitting and set aside.
2. Remove the Inlet CPVC Ring Nut and Plug.
3. Relocate and tighten the CPVC Ring Nut and Plug to the right side of the In/Out Header.
4. Reroute and install the thermostat sensor to the right side of the In/Out Header.

RIGHT INLET / LEFT OUTLET PLUMBING

1. Rotate and remove the PRV and reducer bushing from the In/Out Header.
2. Rotate and remove the T&P Gauge.
3. Remove cover from the Flow Switch and disconnect the wiring.

4. Rotate and remove the Flow Switch from the In/Out header.
5. Relocate the PRV and reducer bushing to where the Flow Switch was located.
6. Tighten down the PRV and position the outlet toward the right jacket side.
7. Relocate the Flow Switch to where the PRV was located.
8. Tighten down the Flow Switch and position the arrow on the flow switch to the left jacket side.
9. Rewire the Flow Switch; one lead on C (common), the second on NO (normally open).
10. Place the cover over the Flow Switch and tighten down the screw.
11. Re-install the T&P Gauge.

LOOSE PLUMBING PARTS

The loose parts bag contains the pieces needed to connect your plumbing to the heater. Two options are recommended for the installer, as shown in the following images. The loose parts bag contains the pieces needed to connect your plumbing to the heater. Verify that all components on the Accessories list are accounted for (see Figure #3 for more details). Before installation, see Figures #21 & 22 for correct water flow orientation. With the supplied CPVC Tee, be sure to install the flow switch on the inlet side with the water supply. (The arrow on flow switch should be pointing towards heater). Fork terminals are provided by the conduit attached to the heater. Remove the flow switch cover and route the two fork terminals through the side of the flow switch. Attach the ring nut on the inside wall of the flow switch against the conduit and tighten. Attach the Orange wire fork to the "N.O." contact and the Orange/Black wire fork to the "COM." contact. Finally, re-install the flow switch cover before operation.

NOTE: Use appropriate CPVC primer and glue for attachments.

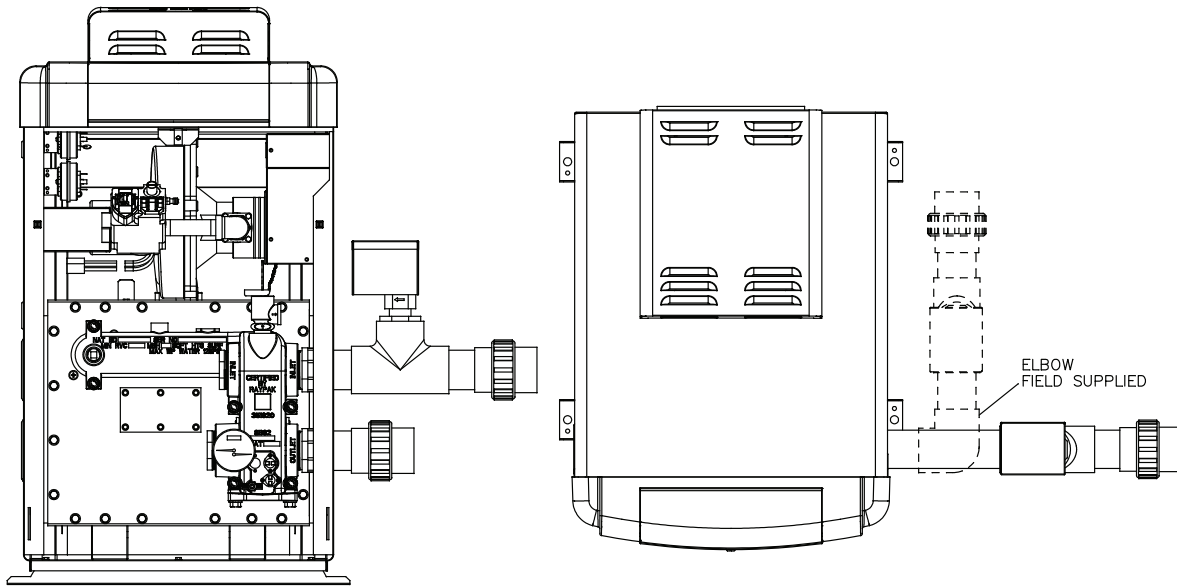

Fig. 22: Recommended plumbing setups

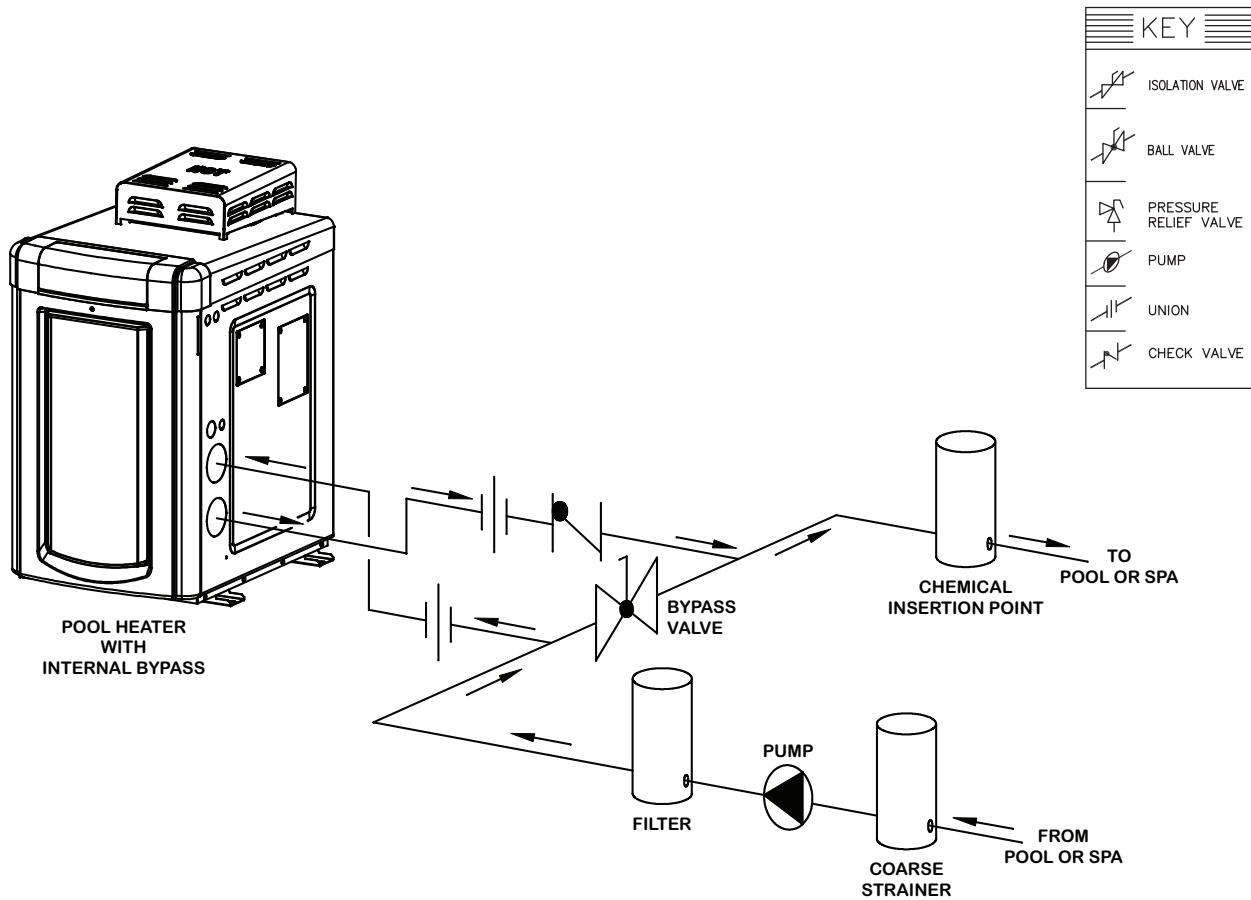

Fig. 23: Single-Unit Installation

THIS DIAGRAM IS RAYPAK'S RECOMMENDATION AND IS NOT INTENDED TO REPLACE AN ENGINEERED PIPING SYSTEM BY A PROFESSIONAL ENGINEER

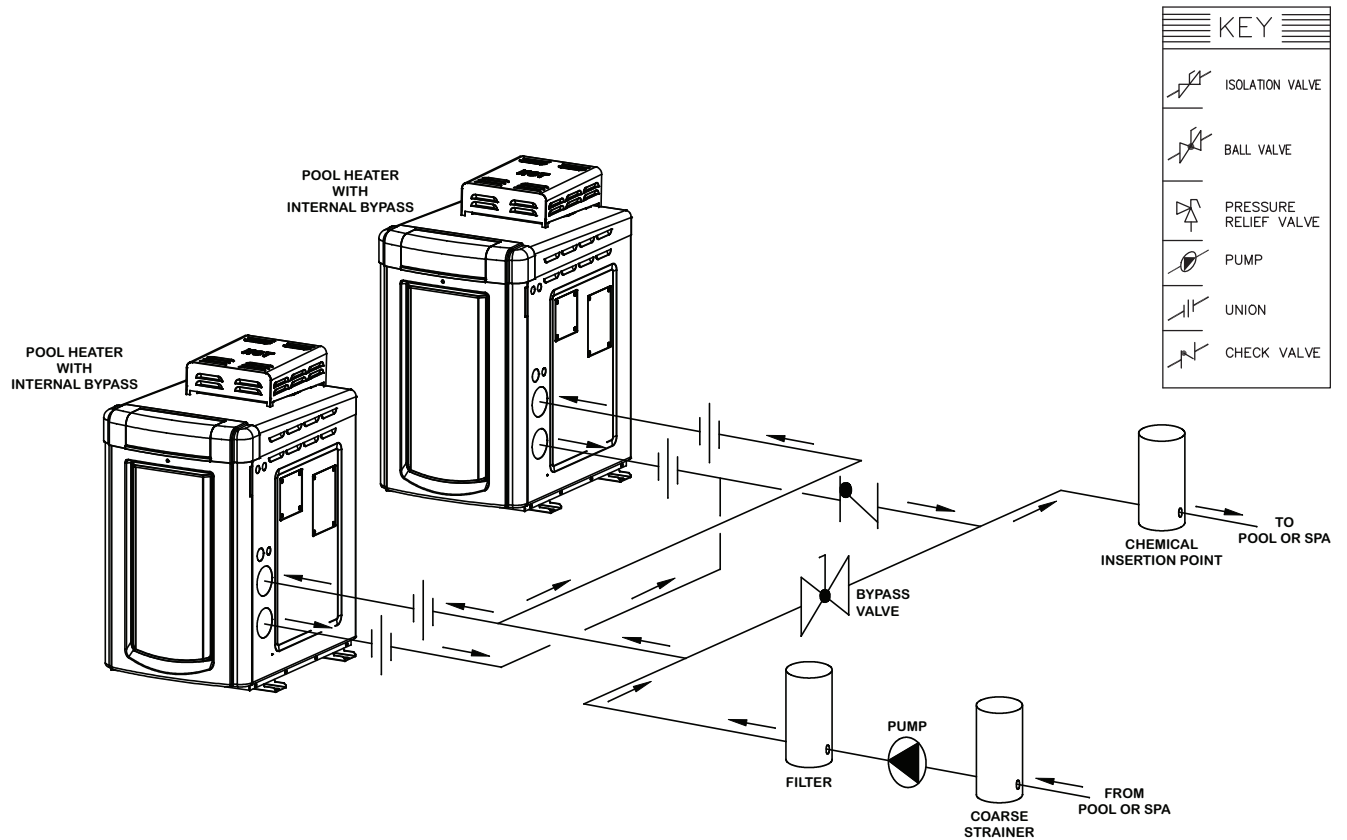

Fig. 24: Multiple-Unit Installation

THIS DIAGRAM IS RAYPAK'S RECOMMENDATION AND IS NOT INTENDED TO REPLACE AN ENGINEERED PIPING SYSTEM BY A PROFESSIONAL ENGINEER

The heater requires water flow and positive pressure to fire and operate properly. It must therefore be installed downstream of the discharge side of the filter pump. A typical installation is plumbed as follows:

1. The inlet side of the filter is plumbed directly to the discharge side of the filter pump;
2. The outlet side of the filter is then plumbed to the inlet of the heater; and
3. The outlet of the heater is plumbed to the return line to the pool or spa. The pump, filter and heater are thus plumbed in series (Salt generators and chemical feeders must be downstream of the pool heater).

Plumbing from the heater back to the pool or spa must not have any valves or restriction that could prevent flow when the pump is operating.

CAUTION: An additional source of heated water, e.g. a solar heating system, must be connected to the main line ahead of the heater inlet pipe in order for it to act as the primary heat source. If the primary system provides adequate heat to maintain setpoint, the heater will not fire. Be advised that the control panel will then display sensed water temperatures downstream of the primary heating system, rather than the temperature of the water exiting the pool.

Heater must be located so that any water leaks will not damage the structure of adjacent area. PVC pipe may be glued directly into header unions.

WIRING DIAGRAM

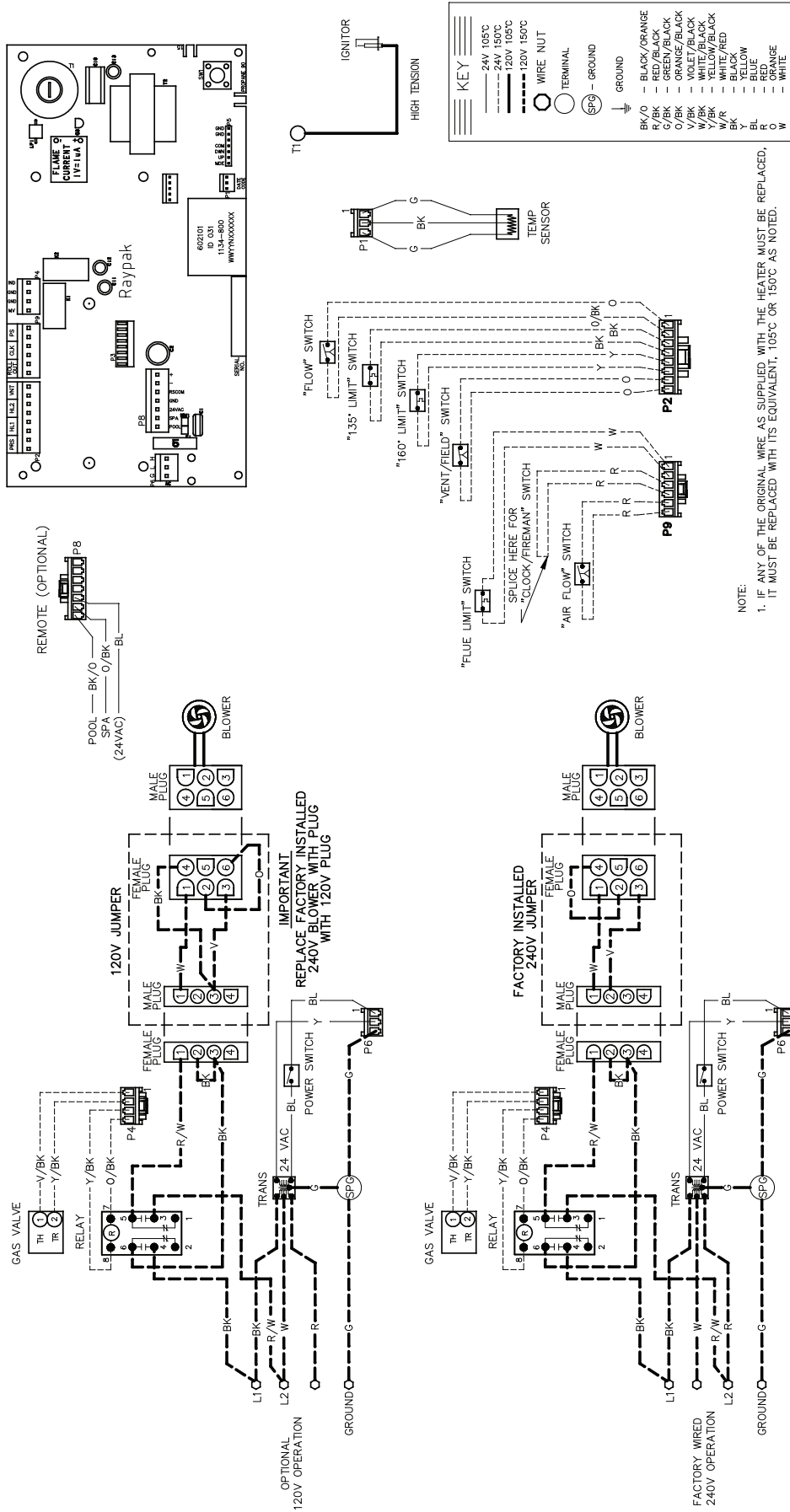

SECTION 4 - SERVICING INSTRUCTIONS

GENERAL LOCATION OF CONTROLS

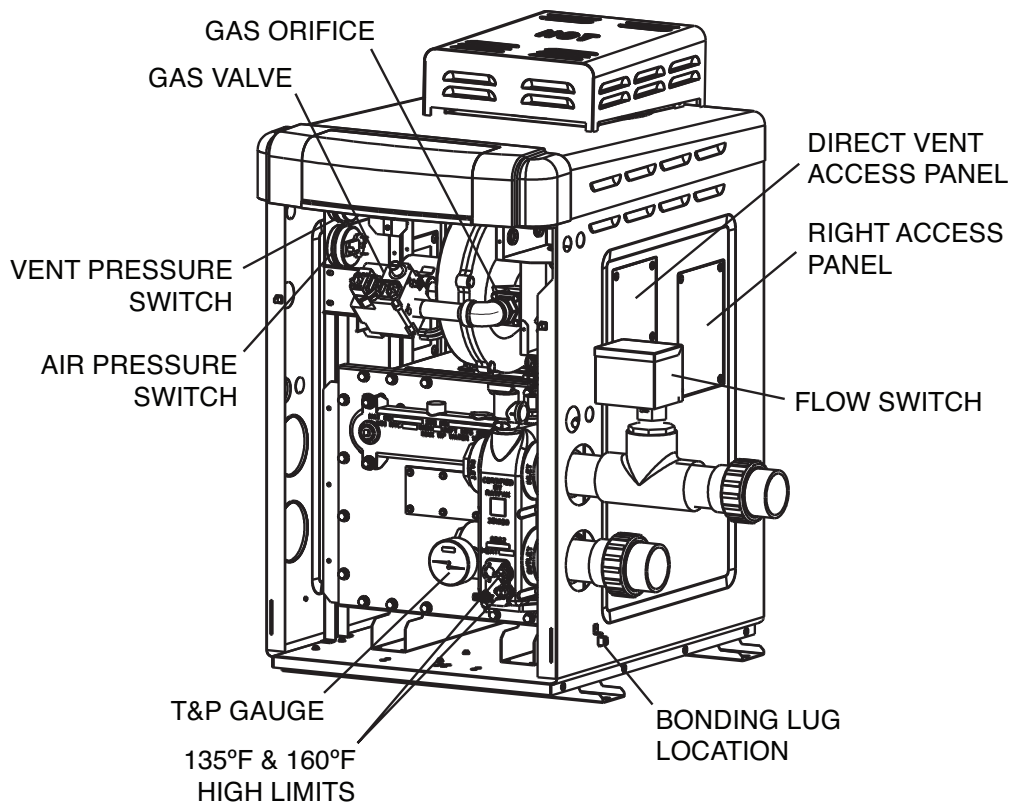
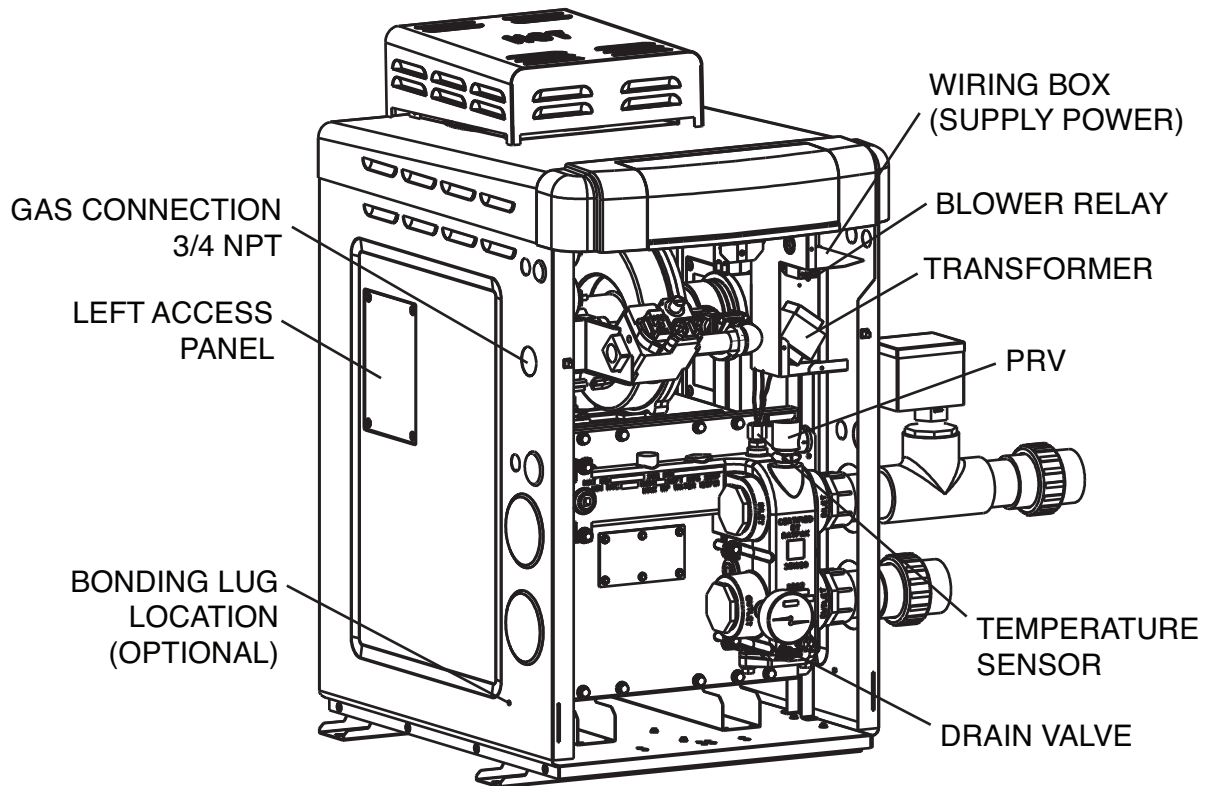

Fig. 25: General Location of Controls

CONTROL ADJUSTMENTS

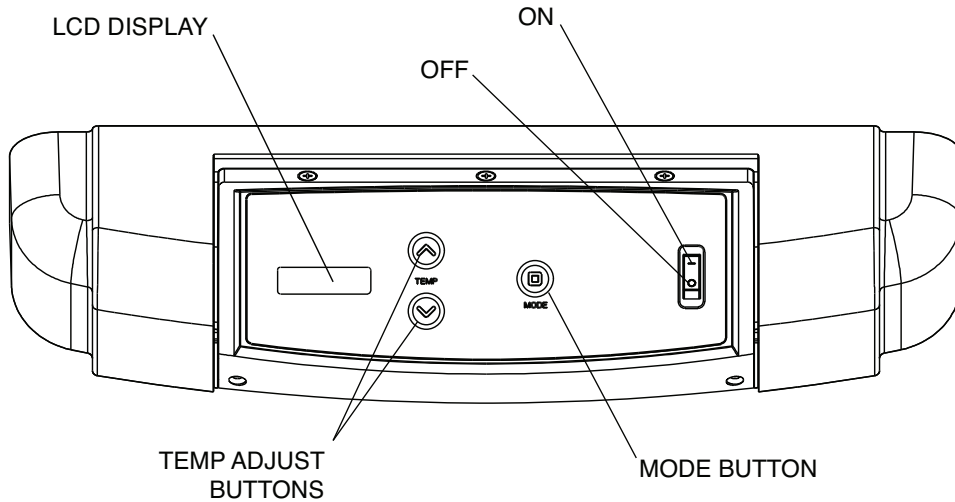

Fig. 26: Control Display

CONTROL PANEL REMOVAL

To remove the PC board from the heater, use Fig. 27 and the following procedure:

1. Turn off main power to the heater.
2. Remove front door to access wire harnesses.
3. Reaching underneath the PC board, carefully remove all connectors and wires from the PC board and ON/OFF toggle switch.
4. Lift the front bezel lid and remove the two lower Phillips screws.
5. Carefully lift the control panel upwards and pull away from the heater.
6. The control panel can now be flipped around to remove or inspect the PC board.
7. Reverse procedure for re-installation.

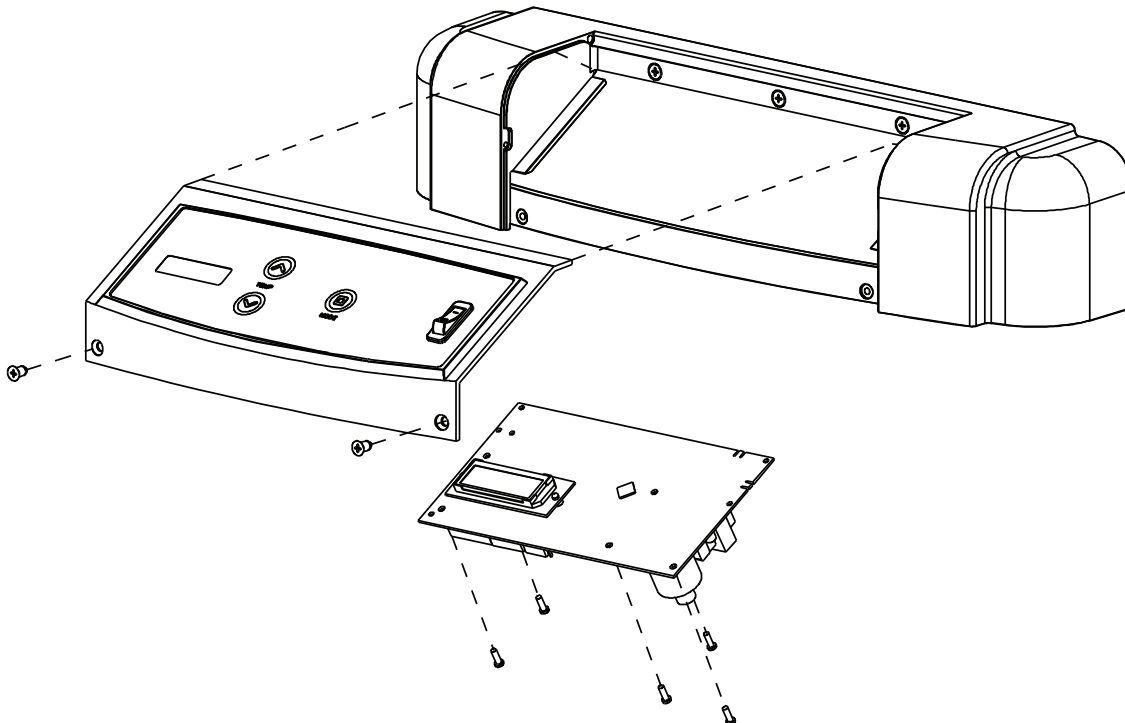

Fig. 27: Control Panel Removal

THERMOSTAT OPERATION - DIRECT SPARK (DS) BOARD

The pool heater touchpad, located on the upper front panel of the heater, allows the user to select either POOL or SPA operation, and to adjust the setpoint temperature. The LCD display window indicates the mode (OFF, SPA, POOL) and the actual water temperature. A manual power switch provided turns the control power ON or OFF. See Fig. 26.

Mode Button

The MODE button is used to select either POOL or SPA operation. It also allows the user to turn the heater off electronically, allowing the LCD display to remain energized and to continue showing the actual water temperature.

Temp Buttons

If the heater is in POOL or SPA mode, the desired water temperature (SETPOINT) will also be displayed and may be adjusted using the UP or DOWN buttons.

Operation

In the POOL or SPA modes, the actual water temperature is displayed along with the desired water temperature (SETPOINT). When the water temperature is above the setpoint, "Water Temp" will alternate with "No Demand." When the water temperature is below the setpoint and the heater is firing, "Water Temp" will alternate with "Heating."

To adjust the setpoint temperature, make sure the control is in the appropriate mode (POOL or SPA) and push the UP or DOWN buttons.

Pool Set 65F
Water Temp 60F

Pool Set 65F
Heating

ALTERNATING DISPLAYS DURING HEATING

Service Menu and Fault History

To access the Service Menu and fault history, press the MODE and UP buttons simultaneously for 3 to 5 seconds. The heater will continue to operate normally while in the Service Menu. The first screen displayed is the Flame Strength indicator, which indicates the pilot flame current using a bar graph and numerical display. A signal of less than 4 indicates a weak flame signal and may require service. Refer to Section 5 – Troubleshooting for possible causes and corrections.

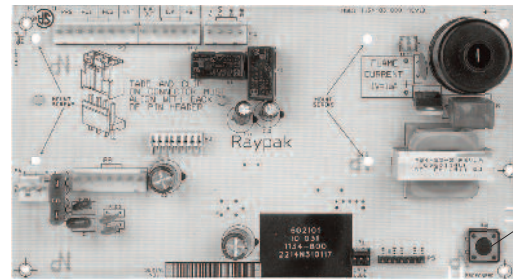

Program Button (SW1)

Fig. 28: SW1 Button

Flame Strength
■■■■■■■■ 8 Good

FLAME STRENGTH INDICATOR

Press the DOWN button. The Supply Voltage screen indicates the voltage supplied to the control board. Normal readings range from 24 to 29 volts.

Supply Voltage
28.2

SUPPLY VOLTAGE INDICATOR

Press the DOWN button. The Run Time indicates the total hours of operation for the pool heater, as measured by the amount of time that the main gas valve has been powered. The Cycle count indicates the number of on/off cycles of the heater, as measured by the number of times the pilot valve has been powered.

Run Time
Cycles

RUN TIME INDICATOR

Press the DOWN button. The Fault History can display up to ten faults in memory. The order of the faults begins with "Fault Last," which is the most recent fault, and proceeds through ten most recent messages in chronological order. The second line of the display shows the fault message. If there are no faults in the history buffer, the second line reads "All Faults Clear."

Faults Last
All Faults Clear

FAULT HISTORY

Program Button

- 1) Follow the instructions on page 34 to remove the control panel. Locate the Program Mode button (marked as SW1) as shown on page 35. Press and hold the button (5-7 seconds) until **Set Factory Defaults** appears on the display. Release the program button.
- 2) Press the MODE button sequentially until the desired program event is reached. There are 5 different events that can be programmed. They appear in the sequence listed below:

Set Factory Defaults	Resets board to factory default settings.
Defaults Set	
Clear Faults	Resets faults in the History File.
Faults Cleared	
Fahrenheit	Change from Fahrenheit to Celsius.
Celsius	
Spa Max Temp 104F	SPA setpoint maximum adjustment.
Pool Max Temp 104F	POOL setpoint maximum adjustment.

Set Factory Defaults

Refer to step one above to access the program screen. **Set Factory Defaults** should appear on the screen. If it does not, press the MODE button until **Set Factory Defaults** appears on the digital display. Press and hold both UP and DOWN buttons for 5-7 seconds until **Defaults Set** appears. This operation resets the operating program to its factory default values. Both the POOL and SPA setpoints will revert to 65°F (18.5°C) and both POOL and SPA maximum temperature settings will be 104°F (40.0°C). The Control Lockout PIN will be cleared and the control will resume normal operation.

Clear Faults

Refer to step one above to access the program screen. Press the MODE button until **Clear Faults** appears on the digital display. Press and hold both UP and DOWN buttons for 5-7 seconds until **Faults Cleared** appears. This operation resets the Fault History file to "0" and clears all the stored faults.

Fahrenheit or Celsius

Refer to step one above to access the program screen. Press the MODE button until **Fahrenheit** or **Celsius** appears on the digital display. The digital display is capable of displaying Celsius as well as Fahrenheit temperatures. The UP or DOWN buttons will select **Fahrenheit** or **Celsius** on the temperature display. Choose the desired temperature scale.

Spa Max Temp – Spa Set Point Maximum Adjustment

Refer to step one above to access the program screen. Press the MODE button until **Spa Max Temp** appears on the digital display. Using the UP and DOWN buttons will change the Maximum Temperature Setting to your desired value. The control can be set for a maximum of 107°F.

Pool Max Temp – Pool Set Point Maximum Adjustment

Refer to step one above to access the program screen. Press the MODE button until **Pool Max Temp** appears on the digital display. Using the UP and DOWN buttons will change the Maximum Temperature Setting to your desired value. The control can be set for a maximum of 107°F.

Control Lockout

The heater is equipped with a Control Lockout feature to prevent unauthorized tampering or adjustment of the control settings. To lock out the controls, press the DOWN button and MODE button for 5 seconds. Choose a three digit PIN, using the UP and DOWN buttons to select the digits and the MODE button to lock in selections. Confirm your selection and record your PIN.

To unlock the controls, press any button to bring up the **Enter PIN** menu. Enter the PIN that was used to lock the control. Note that power cycling will **not** clear the lockout. Successfully unlocking the control will display "Lockout Cleared." Failure to enter the correct PIN will display "Invalid PIN."

In the event that the user-selected PIN is lost or does not clear the Control Lockout, use the Program Button to **Set Factory Defaults**. This will clear the PIN and allow normal operation and selection of a new PIN if desired. See the **Program Button** directions on this page for details.

NOTE: Both the POOL and SPA setpoints will revert back to 65°F (18.5°C) and the POOL and SPA maximum temperature settings will be 104°F (40.0°C). These setpoints will need to be readjusted to desired settings.

NOTE: The LCD temperature display may not agree with the temperature reading of your pool or spa thermometer. The heater reads the water temperature at the inlet. Due to the circulation characteristics of any pool or spa, the water temperature at the inlet to the heater may differ from that observed at a given location in the pool or spa.

STATUS AND DIAGNOSTICS

The digital thermostat models are programmed to display a variety of status and diagnostic messages, depending on the operating conditions.

The following heat status messages are displayed in Pool, Spa, and Remote modes when there are no active fault conditions.

Display	Condition
Heating	Call for heat established, flame present
Spark	Spark operating
No Demand	Heat demand is satisfied or the unit is in its 30-second post-purge timeout
Pre Purge	Blower is powered for a 45-second purge prior to trial for ignition.

The following conditions are displayed in Pool, Spa and Remote modes.

Display	Condition
Sensor Failure	Thermistor temperatures disagree by more than 2°F
Sensor Open	Thermistor sensor failed open. (Below -25°F)
Sensor Short	Thermistor sensor failed short. (Above 213°F)
Flame w/o CFH	Board is sensing flame when both main and pilot valves are commanded shut.
MV Output Fault	Main gas valve output is not in commanded state.
Internal Fault	Board fault, replace board.
EEPROM Fault	Memory fault. Cycle power and reset set points. Replace board if fault does not clear.
Clock/Fireman Sw	Time clock/fireman switch circuit is open.
Low Temp Lockout	Water temperature below 36°F.

The following conditions are displayed only while there is a demand for heat present.

Display	Condition
Water Sw Open	Water flow switch open.
Blocked Vent	Blocked switch is open.
Hi Limit 1 Fault	High limit 1 open.
Hi Limit 2 Fault	High limit 2 open.
Vent Temp Limit	Unused spare circuit is open.
Air Flow Sw Open	Air pressure switch not closed within 10 seconds of blower activation.
Air Flow Sw Closed	Air pressure switch is closed prior to the blower being turned on.
Fan Lockout	3 fan switch faults within same heat demand cycle, power must be cycled to clear the fault.
Ignition Lockout (Propane Tab Broken)	Alternating with "Ign Failure" - Failure to ignite and sense flame in 4-second trial for ignition with Propane "15" or "90" tab broken.
Ign 60min Delay (Propane Tab Not Broken)	After 3 failed ignition attempts, the heater will lock out for 60 minutes before retrying.
EOL	End of Line Test. Mode button stuck in closed position.

Table K: Display Messages

REMOTE CONTROL INSTALLATION AND OPERATION

CAUTION: Before installing remote controls to the heaters, read the following:

The digital thermostat model is remote-ready in most cases. The digital liquid crystal display (LCD) shows the actual pool temperature, operating status, and service codes (See examples below). The touch pad on the control panel allows you to select the desired pool or spa temperature. It also indicates when a remote system is controlling the heater by displaying **Remote** in the display. When connecting the heater to a remote system, identify whether it is a two- or three-wire remote system. Select the appropriate instruction listed below to properly install the remote to the heater.

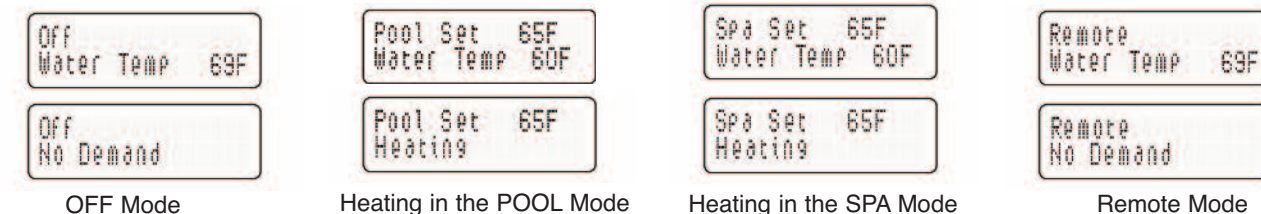

Fig. 29: 7-PIN Remote Interface Harness

REMOTE OPERATION

The heaters are equipped with the ability to work with external remote controls. The supplied 7-pin remote wiring connector supplies power out to either a toggle switch or the switch contacts of a third party remote. The remote works by either making or breaking the circuit created by the remote wiring. Typically, a remote does not supply power to the heater, it only provides a switching function to turn the heater On or Off. **If your remote is supplying its own voltage to the heater, it will not work with this heater and may damage the digital circuit board.**

For operation of the heater using the onboard thermostat controls with a time clock, see the "Time Clock / Fireman's Switch" section.

ACTIVATING THE REMOTE

To activate or deactivate the remote function, follow these steps:

Press and hold the UP and DOWN arrow buttons for 3 to 5 seconds. See Fig. 26.

The second line of the display will alternate even when the unit is off ("No Demand").



NOTE: When in remote operation, the keypad mode and temp buttons are disabled.



Note: Electrostatic Discharge (ESD) damage can be caused by direct or indirect contact with the wiring or circuit board. When one walks to the heater area, an electrostatic charge accumulates on the body. Contact of a finger allows the body to discharge, possibly causing device damage. This damage can be limited if the service person discharges himself, following ESD preventive/removal practices, and holds on to the heater enclosure for 5 seconds before proceeding.

REMOTE CONTROL WIRING

Important Installation Notes for Remote or External Wiring Configuration

- Remote wiring must be run in a separate conduit.
- Remote wiring must not be run parallel to high voltage lines.
- For runs of under 30 feet, remote wiring should have stranded conductors with a minimum of 22 AWG, 600V, cable twisting 1.5 to 2.5 in. lay and jacketed.
- For runs over 30 feet, the conductors should be a minimum of 20 AWG, 600V, cable twisting 1.5 to 2.5 inch lay that is shielded and jacketed.
- Maximum cable length is 200 feet.
- For both two- and three-wire remote systems, the provided 7-pin wiring connector must be utilized. Please refer to the wiring instructions.

NOTE: The remote wires must be connected to the 7-pin connector **before** the connector is plugged into the board.

2-Wire Remote Control (On-Off)

This application assumes that only one heating function (pool or spa) is required.

1. Turn on power to the heater.
2. For a 2-Wire Remote Control from a remote without its own sensor, push the mode button to the "POOL" or "SPA" mode and set the desired setpoint (eg. 102 °F for Spa).
3. For a 2-Wire Remote Control from a remote with its own sensor, push the mode button "POOL" or "SPA" mode and set the temperature to the highest setting available on the control. The actual setpoint will be controlled by the remote control. See Fig. 30.
4. Turn the mode button to "OFF" and remove power from the heater.
5. On the "Remote Interface Harness", connect the BLUE wire to one side of the "REMOTE" switch and connect the other side to either the ORANGE/BLACK wire for "SPA" operation or the BLACK/ORANGE wire for "POOL" operation.
6. Attach wire nut on unused wire to the "Remote Interface Harness."
7. Install the "7-Pin Remote Interface Harness" to the P8 connector and turn power "ON" to the heater.

To activate the remote control, see page 38.

3-Wire Remote Control Using Three-Position Switch (Pool-Off-Spa, or Low-Off-High)

This application assumes that both heating functions (pool and spa) are required.

1. Turn on power to the heater.
2. Push the mode button to the "POOL" or "SPA" mode and set the desired temperature for each (eg. 80°F for Pool and 102°F for Spa). See Fig. 30.
3. Turn the mode button to "OFF" and remove power from the heater.
4. On the "Remote Interface Harness" connect the BLUE wire to one side of the "REMOTE" switch and connect the ORANGE/BLACK wire for "SPA" operation and the BLACK/ORANGE wire for the "POOL" operation.
5. Install the "Remote Interface Harness" to the P8 connector and turn power "ON" to the heater.

To activate the remote control, see page 38.

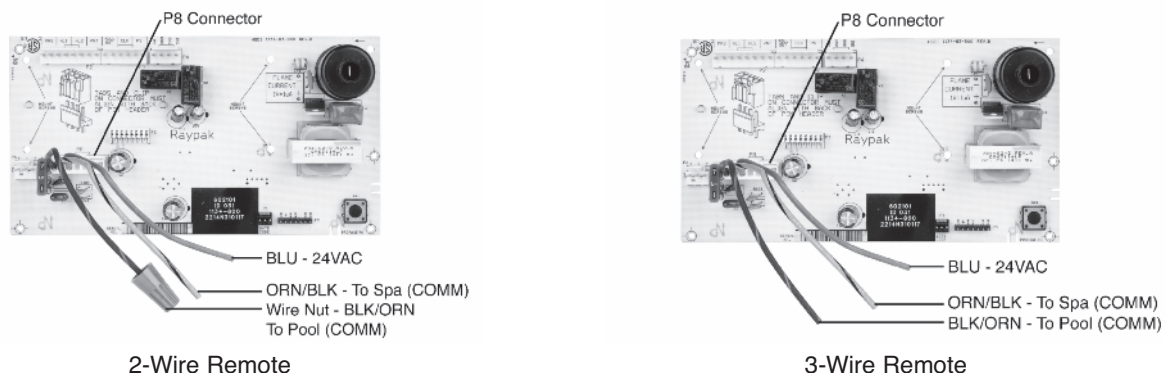

Fig. 30: Remote Control Wiring

TIME CLOCK/FIREMAN'S SWITCH

To operate the heater with a time clock, connect the timer to the fireman's switch connection in the heater's wiring. The time clock should be of the dual switch type and set to shut off the call for heat to the pool heater 15 to 20 minutes prior to shutting down the pool pump. The fireman's switch connection is located on the 6-pin header connected to the digital control board. Splice into the red wire jumper tagged "Where necessary add Fireman's switch circuit here" to connect the time clock. **The fireman's switch connection must be a dry contact and must not supply power to the heater. Powering the fireman's switch connection externally may damage the heater, and is not covered by warranty.**

Do not exceed 50 ft of total wiring using 18 AWG stranded copper wire rated for 105°C (221°F) minimum.

NOTE: When using a time clock, the heater will display "**Clock/ Fireman Sw**" when the fireman's switch is open, indicating that the time clock has shut off the call for heat.

HIGH LIMITS

The heater is equipped with two automatic high limits. Both are located in the inlet/outlet header. One is set at 135°F and the lower one is set at 160°F.

NOTE: An erratic high limit is often characteristic of an internal heat exchanger problem, e.g. scale build-up, defective bypass. Refer to Troubleshooting section (starting on page 42).

HIGH LIMIT REMOVAL

1. Shut off main electrical power switch to heater.
2. Remove front door.
3. Remove defective high limit and replace with a new high limit.
4. Replace inspection panel.

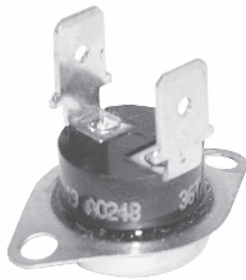

Fig. 31: High Limit

FLOW SWITCH

This standard, dual-purpose control, mounted and wired in series with the main gas valve, shuts off heater in case of pump failure or low water flow.

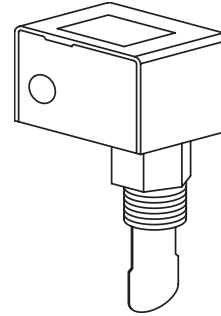

Fig. 32: Flow Switch

AIR PRESSURE & BLOCKED VENT SWITCHES

This heater is equipped with an air pressure switch to prove the operation of the blower before allowing the ignition control to begin a Call for Heat. It is also equipped with a blocked vent pressure switch to prevent the operation of the heater when too much of the vent is blocked.

The two switches appear similar and are mounted next to each other on the heater. They can be distinguished by their mounted positions and by the pressure settings printed on the labels. See Fig. 33.

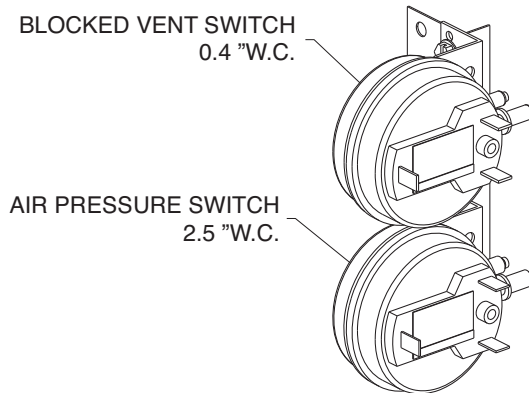

Fig. 33: Air Pressure & Blocked Vent Switch

ADJUSTING VALVE MANIFOLD PRESSURE

1. Remove the cap to gain access to the adjustment screw.
2. Turn the adjustment screw clockwise to increase pressure. (For example, at -0.6"W.C. turning clockwise will increase the pressure to -0.5"W.C., -0.4"W.C., etc.)
3. Install the cap before reading the manifold pressure.

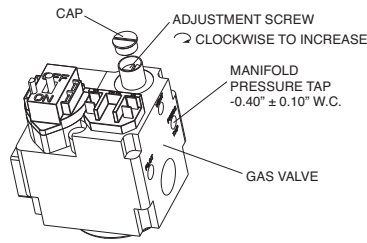

Fig. 34: Manifold Pressure Adjustment

VISUAL INSPECTION

Flames can be observed through the sight glass reflection below the blower motor. A blue-colored flame indicates normal operation. At least every three months a visual inspection should be made.

ELECTRICAL

Be sure that electrical service to the heater has proper overload fuse or circuit breaker protection, wire size and connections which comply with all applicable codes.

CAUTION: Prior to replacing any component, make sure that the main gas, power, and pumps are turned **OFF**.

ORIFICE REMOVAL

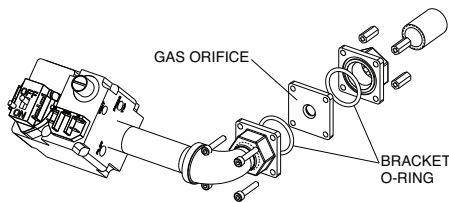

Fig. 35: Orifice Location

1. Locate and close the external manual shut-off valve.
2. Loosen the external gas union.
3. Locate and remove front door panel.
4. Locate and remove the (4) bolts & nuts holding the gas orifice in place. See Fig. 35 above.
5. Carefully remove the gas orifice and do not misplace the O-rings attached to the flanges.
6. Inspect and/or replace the orifice with the correct size.

GAS AND AIR ORIFICE SELECTION

The gas orifice and the air orifice **MUST** match to attain the correct air/fuel ratio. The orifices are matched when the number of pockets on the side of the gas orifice is the same as the number of notches on the edge of the air orifice. The orifice selection is based on elevation, not on the fuel used. See Table L.

The gas orifice is located on the gas train, between the gas valve and the combustion blower. The air orifice is located on the inlet side of the combustion blower.

NOTE: Gas orifices for propane gas have a black oxide finish.

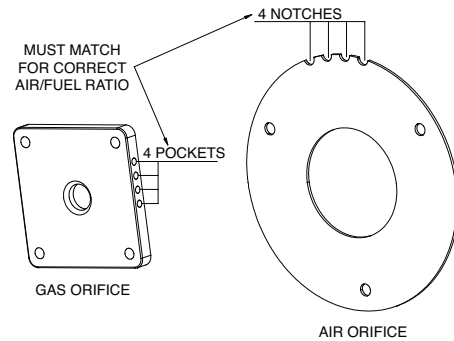

Fig. 36: Orifice Orientation

Pockets / Notches	Model	Elevation
1	409B	0-2000 ft
2	259B	0-2000 ft
3	409B	2000-5000 ft
4	259B	2000-5000 ft
5	409B	5000-7000 ft
6	259B	5000-7000 ft

Table L: Orifice Usage

IGNITER REMOVAL

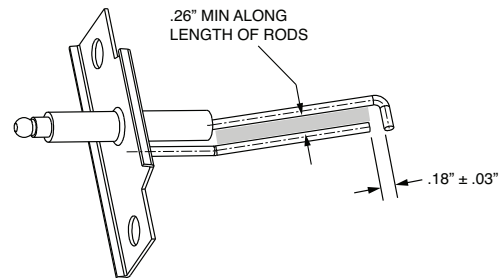

Fig. 37: Igniter

1. Locate and remove front door panel.
2. Locate and remove the accessible left side access panel. You may also reach from the front of the heater or remove the jacket top for better access.
3. Locate the igniter behind the blower.
4. Locate and disconnect the high tension spark cable from the igniter.
5. Using a 5/16" socket, remove the (2) bolts holding the igniter down.
6. Using a flat screw driver, loosen the igniter bracket from the combustion chamber, preferably on both sides.
7. Carefully remove the igniter from its location. The ceramic is fragile, so handle with care.
8. When replacing or inspecting the igniter, the gap between the ground & spark tips should be 0.18"± 0.03". The gap between the rods should be no less than 0.26" along their entire length.

SECTION 5 - TROUBLESHOOTING

MECHANICAL

IMPORTANT NOTICE These instructions are intended for the use of qualified personnel who are specifically trained and experienced in the installation of this type of heating equipment and related system components. Installation and service personnel may be required by some states to be licensed. Persons not qualified shall not attempt to install this equipment nor attempt repairs according to these instructions.

PROBLEM	CAUSE	SOLUTION
Harmonics, or whining noise	*Debris or restriction in system..... *Debris in gas line..... Low flow.....	Locate the restriction and remove. Flush system and clean. Remove debris or blow out gas line. Scale forming in heat exchanger - clean heat exchanger and check pool pH and total alkalinity.
Heater going on and off continuously	Dirty filter..... Low water level in pool..... External bypass setting out of adjustment.....	Clean or replace filter. Raise water level. Adjust bypass.
Valve opens but no flame visible	Manifold pressure too low.....	Increase manifold pressure (turn clockwise slightly).
Flame visible for a split second	Ignition not being sensed.....	Replace ignition wire. Check connections.
Liming or scale forming in exchanger	Pool water..... Bypassing too much water.....	See Water Chemistry on page 2. Inspect bypass for movement, if no movement, replace.
Sooting	High flow rates..... *Air starvation..... *Improper venting..... *Insects or debris clogging burner intake ports.....	Reduce by adding manual bypass valve. Adjust manual bypass valve until heater outlet water temperature is between 105°F and 110°F. Refer to installation instructions. Follow recommended installation instructions. Clean burners.
Yellow lazy flame	Air intake clogged or incorrect fan operation..... *Insects or debris clogging burner intake ports.....	Check for debris upstream of fan intake. Verify Blower Suction Pressure, see page 5, is within range. Clean burner.
Outer jacket very hot (paint blistered)	*Broken refractory caused by shipping damage or improper combustion..... Excessive sooting of heat exchanger....	Replace refractory panels. Determine cause of sooting & correct.
Hard lighting at startup	Igniter faulty.....	Replace igniter
Takes too long to heat pool or spa	Under-sized heater..... Filter not running long enough..... Dirty filter..... Gas line or meter undersized.....	Calculate heating capacity of heater or refer to heater sizing chart. $\text{Heating Capacity} = \frac{\text{Htr. output(BTUH)}}{\text{Pool gallonage} \times 8.33}$ This does not take into account heat loss due to weather. Reset time clock. Clean filter. Refer to installation instructions.
Leaking at well	Overacid.....	Replace well and maintain proper water chemistry.
Leaking at heat exchanger	Overacid.....	Replace heat exchanger and maintain proper water chemistry.
Gasket brittle and leaking - (overheated)	Heater running after pump shuts off.... Refractory damage..... Sooted heater.....	See Pressure Switch Adjustment. Replace refractory. Determine cause of sooting and correct.
Combustion fan not running "Fan 5 min Delay" signal or "Fan Lockout" signal	Fan relay..... Fan..... Burned motor Air pressure switch.....	Replace fan relay. Loose connection or failed motor. Incorrect wiring, replace blower. Replace air switch.
Heater turns on for less than 4 seconds (no display error)	Wiring..... Incorrect supply wiring..... PC Board short..... Ignition not sensed.....	Check for loose or broken (verify continuity) wiring/ground/ignition wire. Check incoming power for correct voltage. There should be no power on the neutral line. Replace board if no strength signal is being detected. Clean igniter with wire brush.

* Indicates symptom which usually occurs on initial start-up.

CONTROL LOGIC - FLOW CHART

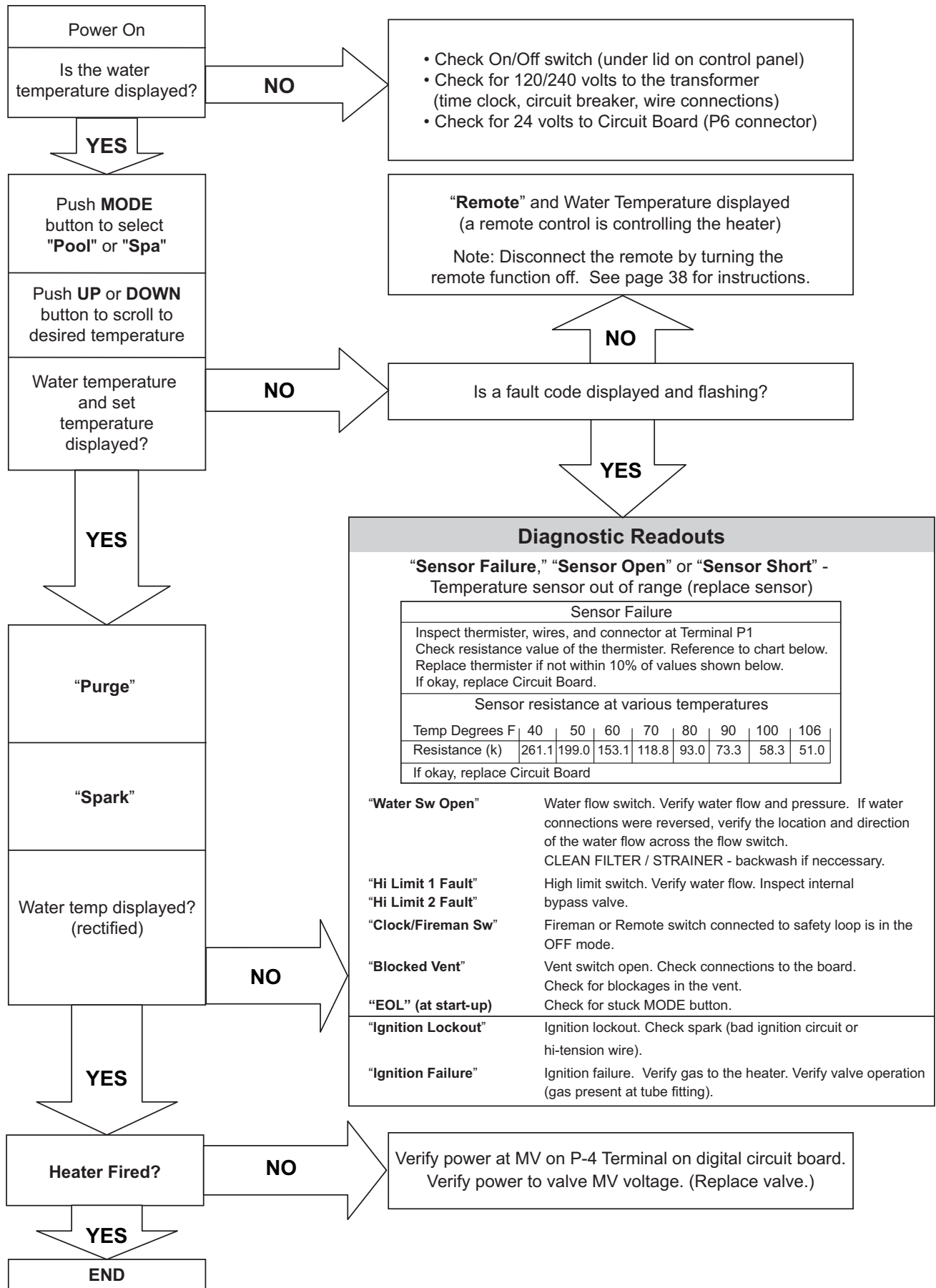

SECTION 6 - REPLACEMENT PARTS

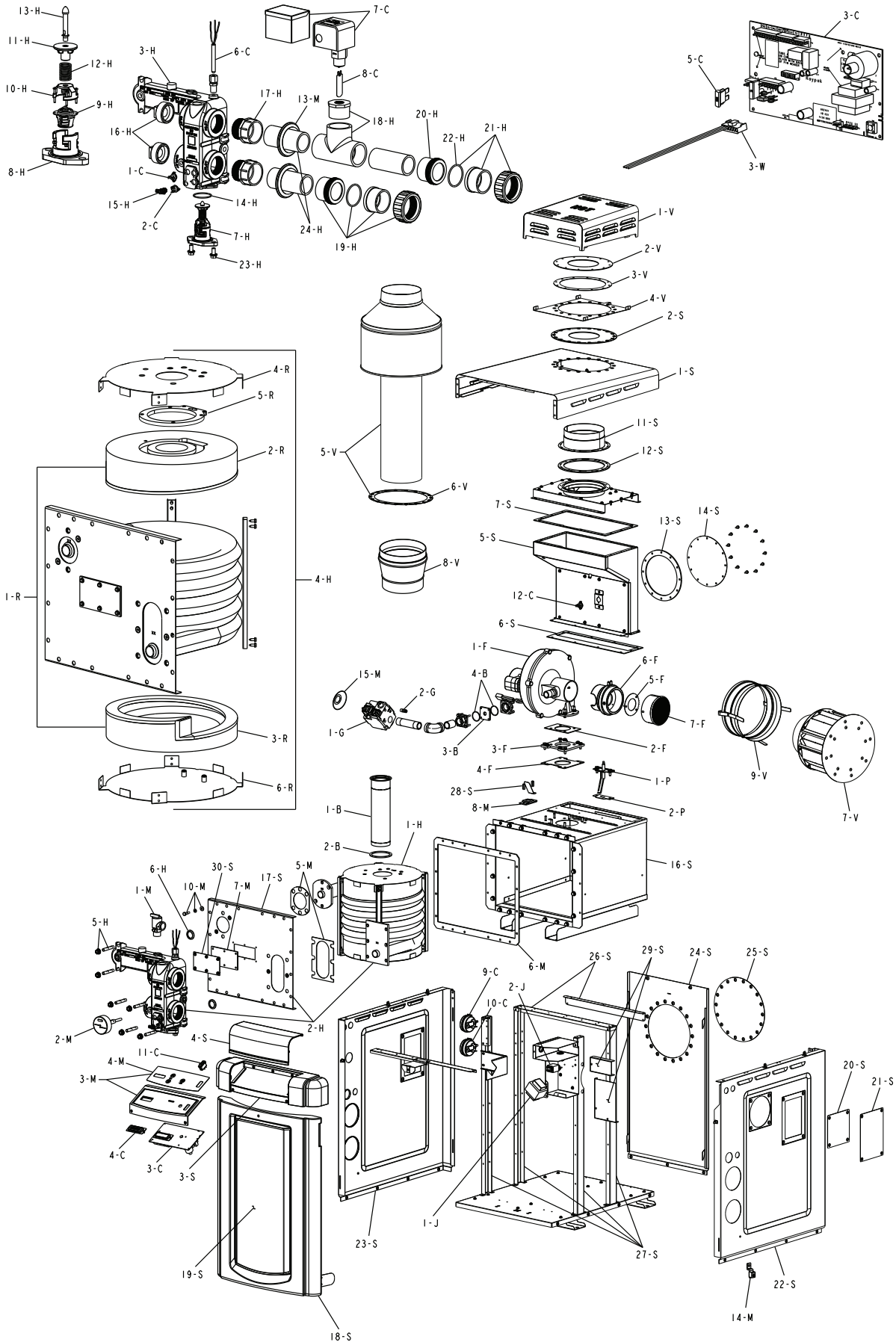

CALL OUT	DESCRIPTION	259B	409B
B	BURNER		
1-B	Burner	014077F	014078F
2-B	Gasket seal	014079F	014079F
4-B	Gas Orifice Natural (0-2000 Ft)*	014082F	014081F
	Gas Orifice Natural (2000-5000 Ft)*	014084F	014083F
	Gas Orifice Natural (5000-7000 Ft)*	014203F	014202F
	Gas Orifice Propane (0-2000 Ft)*	014086F	014085F
	Gas Orifice Propane (2000-5000 Ft)*	014088F	014087F
	Gas Orifice Propane (5000-7000 Ft)*	014205F	014204F
5-B	Gas Orifice Flange O Ring	014089F	014089F
C	CONTROLS		
1-C	Thermostat Auto Reset 135 Deg Surface Mount	006725F	006725F
2-C	Thermostat Auto Reset 160 Deg Surface Mount	016213F	016213F
3-C	P. C. Board/Control	014090F	014090F
4-C	LCD Display	013640F	013640F
5-C	Fuse 5 AMP	013733F	013733F
6-C	Temperature Sensor	009577F	009577F
7-C	Flow Switch with Cover	007142F	007142F
8-C	Flow Switch Paddle	010026F	010026F
9-C	Switch Air Pressure (Vent)	007158F	007158F
10-C	Switch Air Pressure Differential (Blower)	011760F	011760F
11-C	Rocker Switch	009493F	009493F
12-C	Flue Exhaust Limit 400 Deg	016214F	016214F
F	FAN		
1-F	Blower	014091F	014091F
2-F	Blower Gasket	014092F	014092F
3-F	Mounting Plate	014093F	014093F
4-F	Mounting Plate Gasket	014080F	014080F
5-F	Combustion Air Orifice		
	0-2000 Ft	014095F	014175F
	2000-5000 Ft	014208F	014207F
	5000-7000 Ft	014210F	014209F
6-F	Combustion Air Venturi Adapter	014096F	014096F
7-F	Intake Air Vent Cap	012844F	012844F
G	GAS VALVE		
1-G	Combination Valve - Nat.	014097F	014097F
	Combination Valve - Pro.	014097F	014097F
2-G	Bleedle Valve 1/8 NPT	007423F	007423F
H	HEAT EXCHANGER		
1-H	Heat Transfer (Includes Refractory)	016215F	016216F
2-H	Heat Exchange Assy Cupro-Nickel ASME BR	016217F	016218F
3-H	Inlet/Outlet Header ASME BR Complete	016219F	016220F
	Inlet/Outlet Header ASME BR	016221F	016222F
4-H	Tube Bundle Cupro-Nickel ASME ** (Includes Refractory)	016223F	016224F
5-H	Stud Bolt Kit (6)	016225F	016225F
6-H	Header Gasket (2)	014109F	014109F
7-H	U.G. / Bypass Assembly	016227F	016227F
8-H	U.G. Housing	N/A	N/A
9-H	Unitherm Governor	N/A	N/A
10-H	U.G. Retainer	N/A	N/A
11-H	Bypass Valve	N/A	N/A
12-H	Bypass Spring (Silver)	N/A	N/A
13-H	Bypass Shaft	N/A	N/A
23-H	U.G. / Bypass Assy Screws	016902F	016902F
24-H	2" CPVC Pipe	016169F	016169F
14-H	O-Ring Seal U.G. Housing Gasket	016230F	016230F
15-H	Drain Valve 1/4 NPT	014158F	014158F
16-H	Pipe Plug	016233F	016233F
17-H	2" CPVC Adapter	005393F	005393F
18-H	2" CPVC Tee and Reducing Bushing	016234F	016234F
19-H	2" PVC Union Adapter	014161F	014161F
20-H	Adapter with Buttress Threads	014162F	014162F
21-H	2" CPVC Connector & Nut	006723F	006723F
22-H	O Ring	006724F	006724F
J	CONTROL BOX		
1-J	Transformer 120/240/24V	006736F	006736F
2-J	Blower Relay DPDT 24V	011720F	011720F
M	MISCELLANEOUS COMPONENTS		
1-M	PRV 125 PSI	011912F	011912F
2-M	T & P Gauge	014647F	014647F
3-M	Control Bezel (Includes Switch Decal)	014120F	014120F
4-M	Switch/Decal-Membrane	014121F	014121F
5-M	Tube Sheet Inlet & Outlet Gaskets	016235F	016235F
6-M	Heat Exchanger Seal Gasket	016236F	016236F
7-M	Inspection Panel Seal Gasket	016251F	016251F
8-M	Window Combustion Chamber	006947F	006947F
9-M	Blower / Air Pressure Switch Sample Tube (Not Shown)	010348F	010348F
10-M	Fastener Kit (Includes 6 each Bolt & Washers)	014174F	014174F
11-M	Touch-up Paint Cool Dark Gray (Not Shown)	750256	750256
12-M	RTV Sealant 2.8 oz (Not Shown)	008924F	008924F
	RTV Sealant 10 oz (Not Shown)	005755F	005755F
13-M	Seal Gaskets	010780F	010780F
14-M	Wire Bonding Connector	007155F	007155F
15-M	Gas Line Cabinet Flange	016176F	016176F

*FOR INSTALLATION AT OVER 2,000 FEET ABOVE SEA LEVEL, DERATE 4% PER 1,000 FEET ABOVE SEA LEVEL.

**WARNING: The Hydraulic conditions or water chemistry that caused the tube bundle to fail have very likely also damaged the bypass valve and Unitherm Governor. We recommend you replace the Unitherm Governor and inspect the bypass assembly. Failure to do so could cause premature failure of this replacement part.

CALL OUT	DESCRIPTION	259B	409B
P	PILOT		
1-P	Igniter Direct Spark	016238F	016238F
2-P	Igniter Gasket	014125F	014125F
3-P	Hi Tension Wire	014126F	014126F
R	REFRACTORY		
1-R	Refractory Top & Bottom	016239F	016239F
2-R	Refractory Top	016240F	016240F
3-R	Refractory Bottom	016241F	016241F
4-R	Refractory Support Top	016242F	016242F
5-R	Support Mounting Plate	016244F	016244F
6-R	Refractory Support Bottom	016243F	016243F
S	SHEET METAL / CABINET		
1-S	Jacket Top	014132F	014132F
2-S	Flue Exhaust Gasket	014133F	014133F
3-S	Front Control Bezel	014134F	014134F
4-S	Control Bezel Cover	014135F	014135F
5-S	Flue Collector with Top Flue Exhaust	016245F	016245F
6-S	Flue Collector Lower Gasket	014137F	014137F
7-S	Flue Collector Upper Gasket	014138F	014138F
8-S	Flue Collector with Rear Flue Exhaust (Optional)	N/A	N/A
6-S	Flue Collector Lower Gasket	014137F	014137F
7-S	Flue Collector Upper Gasket	014138F	014138F
9-S	Flue Exhaust Gasket Retainer	N/A	N/A
10-S	Flue Exhaust Rear Jacket Gasket	N/A	N/A
11-S	Flue Exhaust Collar		
	4" Connection	015096	N/A
	5" Connection	015097	015097
	6" Connection	009802F	009802F
12-S	Flue Exhaust Gasket	009735F	009735F
13-S	Flue Exhaust Gasket (Rear Flue Exhaust)	009735F	009735F
14-S	Top Flue Exhaust Cover (Optional)	014149F	014149F
15-S	Flue Exhaust Cover Gasket	014133F	014133F
16-S	Chamber Assy	016247F	016248F
17-S	Front Panel	016249F	016249F
18-S	Door Assy	014142F	014142F
19-S	Door Insert SS	014143F	014143F
20-S	Access Panel Intake Air	014144F	014144F
21-S	Access Panel Igniter	014145F	014145F
22-S	Jacket Side Panel Right	014146F	014146F
23-S	Jacket Side Panel Left	014147F	014147F
24-S	Jacket Rear Panel	014148F	014148F
25-S	Rear Flue Exhaust Cover	014149F	014149F
26-S	Upper Cabinet Supports	014150F	014150F
27-S	Vertical Cabinet Supports	014151F	014151F
28-S	Window Reflector	014152F	014152F
29-S	Control/Wiring Box Covers	016250F	016250F
30-S	Inspection Panel (Includes 7-M)	016237F	016237F
V	VENTING		
1-V	Stackless Top	014154F	014154F
2-V	Flue Exhaust Gasket	014155F	014155F
3-V	Flue Exhaust Gasket Retainer	014156F	014156F
4-V	Retainer Stackless top Mtg	014157F	014157F
5-V	Outdoor Stack (High Wind Conditions Only)	013978	013978
6-V	Flue Exhaust Gasket Retainer	010030F	010030F
7-V	Horizontal Vent Termination 4"	014289	N/A
	Horizontal Vent Termination 5"	014288	014288
	Horizontal Vent Termination 6"	014159	014159
8-V	Flue Exhaust Outlet Adapter 6" x 7"	014050	014050
	Flue Exhaust Outlet Adapter 6" x 8"	014051	014051
	Flue Exhaust Outlet Adapter 6" x 9"	014052	014052
9-V	Flue Exhaust Adapter 4"	008776	N/A
	Flue Exhaust Adapter 5"	007004	007004
	Flue Exhaust Adapter 6"	007005	007005
W	WIRING		
1-W	Wire Harnesses (All Unit Harnesses)	014117F	014117F
2-W	Blower Harness 120V	014118F	014118F
	Blower Harness 240V	014119F	014119F
3-W	Remote 3 Wire Harness	015518F	015518F
CONVERSION KITS*		259B	409B
	Nat. to Pro.	N/A	N/A
	Pro. to Nat.	N/A	N/A

* Gas conversions are to be done only by a qualified agency.

NOTE: To supply you with the correct part, it is important that you supply the heater model number, serial number and type of gas when applicable.

If determined defective by the Company and within warranty, a like part or equal substitution will be returned, freight collect. Credit will not be issued.

Any part returned for replacement under standard company warranties must be properly tagged with a return parts tag, completely filled in with the heater serial number, model number, etc., and shipped to the Company freight prepaid.

MANUFACTURER:

2151 EASTMAN AVENUE
OXNARD, CA 93030

Important Instructions for the Commonwealth of Massachusetts

The Commonwealth of Massachusetts requires compliance with regulation 248 CMR 4.00 and 5.00 for installation of through – the – wall vented gas appliances as follows:

(a) For all side wall horizontally vented gas fueled equipment installed in every dwelling, building or structure used in whole or in part for residential purposes, including those owned or operated by the Commonwealth and where the side wall exhaust vent termination is less than seven (7) feet above finished grade in the area of the venting, including but not limited to decks and porches, the following requirements shall be satisfied:

1. INSTALLATION OF CARBON MONOXIDE DETECTORS. At the time of installation of the side wall horizontal vented gas fueled equipment, the installing plumber or gasfitter shall observe that a hard wired carbon monoxide detector with an alarm and battery back-up is installed on the floor level where the gas equipment is to be installed. In addition, the installing plumber or gasfitter shall observe that a battery operated or hard wired carbon monoxide detector with an alarm is installed on each additional level of the dwelling, building or structure served by the side wall horizontal vented gas fueled equipment. It shall be the responsibility of the property owner to secure the services of qualified licensed professionals for the installation of hard wired carbon monoxide detectors

a. In the event that the side wall horizontally vented gas fueled equipment is installed in a crawl space or an attic, the hard wired carbon monoxide detector with alarm and battery back-up may be installed on the next adjacent floor level.

b. In the event that the requirements of this subdivision can not be met at the time of completion of installation, the owner shall have a period of thirty (30) days to comply with the above requirements; provided, however, that during said thirty (30) day period, a battery operated carbon monoxide detector with an alarm shall be installed.

2. APPROVED CARBON MONOXIDE DETECTORS. Each carbon monoxide detector as required in accordance with the above provisions shall comply with NFPA 720 and be ANSI/UL 2034 listed and IAS certified.

3. SIGNAGE. A metal or plastic identification plate shall be permanently mounted to the exterior of the building at a minimum height of eight (8) feet above grade directly in line with the exhaust vent terminal for the horizontally vented gas fueled heating appliance or equipment. The sign shall read, in print size no less than one-half (1/2) inch in size, "GAS VENT DIRECTLY BELOW. KEEP CLEAR OF ALL OBSTRUCTIONS".

4. INSPECTION. The state or local gas inspector of the side wall horizontally vented gas fueled equipment shall not approve the installation unless, upon inspection, the inspector observes carbon monoxide detectors and signage installed in accordance with the provisions of 248 CMR 5.08(2)(a)1 through 4.

(b) **EXEMPTIONS:** The following equipment is exempt from 248 CMR 5.08(2)(a)1 through 4:

1. The equipment listed in Chapter 10 entitled "Equipment Not Required To Be Vented" in the most current edition of NFPA 54 as adopted by the Board; and

2. Product Approved side wall horizontally vented gas fueled equipment installed in a room or structure separate from the dwelling, building or structure used in whole or in part for residential purposes.

(c) **MANUFACTURER REQUIREMENTS - GAS EQUIPMENT VENTING SYSTEM PROVIDED.** When the manufacturer of Product Approved side wall horizontally vented gas equipment provides a venting system design or venting system components with the equipment, the instructions provided by the manufacturer for installation of the equipment and the venting system shall include:

1. Detailed instructions for the installation of the venting system design or the venting system components; and

2. A complete parts list for the venting system design or venting system.

(d) **MANUFACTURER REQUIREMENTS - GAS EQUIPMENT VENTING SYSTEM NOT PROVIDED.** When the manufacturer of a Product Approved side wall horizontally vented gas fueled equipment does not provide the parts for venting the flue gases, but identifies "special venting systems", the following requirements shall be satisfied by the manufacturer:

1. The referenced "special venting system" instructions shall be included with the appliance or equipment installation instructions; and

2. The "special venting systems" shall be Product Approved by the Board, and the instructions for that system shall include a parts list and detailed installation instructions.

(e) A copy of all installation instructions for all Product Approved side wall horizontally vented gas fueled equipment, all venting instructions, all parts lists for venting instructions, and/or all venting design instructions shall remain with the appliance or equipment at the completion of the installation.



www.raypak.com

Raypak, Inc., 2151 Eastman Avenue, Oxnard, CA 93030 (805) 278-5300 Fax (805) 278-5468
Litho in U.S.A.