

Job: _____
 Engineer: _____
 Contractor: _____
 Prepared By: _____ Date: _____
 Model: _____ Indoor/Outdoor: _____

MVB® - Type P

Pool Heaters
 Models 504-2004

- 85% Thermal Efficiency**
- 100% Factory Fire Tested**
- Minimum Acceptable Inlet Water Temperature: 105°F**
- Full Safety Diagnostics with History**
- Footprint: Less Than 5-1/2 ft²**
- Limited Twenty-Year Thermal Shock Warranty**
- Limited Five-Year Heat Exchanger Warranty**
- On/Off Firing**
- Soft-Start Modulating Controller with LCD Display**
- Status Display Lights**

Pump included
 standard

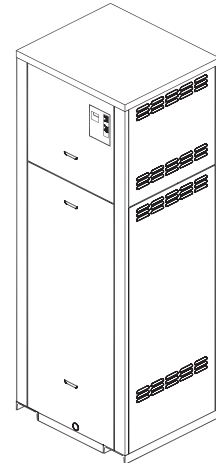

Proudly Made in the USA

Heat Exchanger

- Bronze Headers
- ASME HLW Stamped
160 PSIG Working Pressure
- National Board Approved
- Cupro Nickel Fin Tubing
- ASME Powder-Coated Tube Sheet
- Silicone High Temp O-Rings
- ASME Pressure Relief Valve,
125 PSIG
- Temperature and Pressure Gauge,
Shipped Loose
- Stainless Steel Evaporator Plate
- Bronze Pump (See table on pg. 2)
- Drain Valves (2)
- Air Vent

Control

- 120V, 60Hz, 1Ø, Power Supply
- 120/24V 60Hz Transformer
- Ignition Module
 - 3-Try – Standard
 - Single-Try – Option C-6
- Hot Surface Ignition (HSI)
- Remote Flame Sensor
- High Limit, Auto Reset, Adj., 140°F
- High Limit, Manual Reset, Fixed
Models 504-1504: 175°F
Models 2004: 200°F
- On/Off Power Switch
- Flow Switch, Mtd
- Blocked Vent Pressure Switch
- Combustion Air Proving Switch
- Pump Switch
- Pump Time Delay
- Diagnostics Panel

Control (cont.)

- On/Off Digital Poolstat, 106°F Max
- Water Temperature Sensors (3) with
Immersion Well

Burner

- Ultra-Low NOx: Less than 20 PPM

Gas Train

- Fuel
 - Natural Gas
 - Propane
- Zero Governor Regulator
- Dual-Seat Combination Valve
- On/Off Firing with Soft-Start

Construction

- Indoor/Outdoor Construction
- Enclosed Front Controls
- PolyTuf Powder Coat Finish
- Rear Connections (Water, Electrical,
Gas, Vent, Combustion Air)
- Design Certification
ANSI Z21.56/
CSA 4.7
- CSA Low Lead Certified ≤ .25 Pb

Venting

- Vent Termination Cap
 - Outdoor – Option D-11
 - Indoor, Horizontal – Option D-15
 - Indoor, Vertical (by others)
- Combustion Air
 - In-Line Filter Kit – Option D-17
 - Air Intake Elbow – Option D-16
- Extractor – Optional
 - By others
 - Not required

Temperature Controllers

- B-26 TempTracker Digital Controller,
Up to 2 Heaters
- B-21 TempTracker Digital Controller,
Up to 4 Heaters
- B-___ TempTracker Mod+ (Up to 16
Boilers)

Options

- F-10 Low Water Cut-Off, Remote
Probe
- P-___ Cold Water Run
- P-___ H-style Bypass, Non-Ferrous
- S-1 Low Gas Pressure Switch,
Manual Reset
- S-2 High Gas Pressure Switch,
Manual Reset

Regulatory Agency Requirements



Raypak®
 A Rheem® Company

MVB – Type P Models 504-2004

Model _____

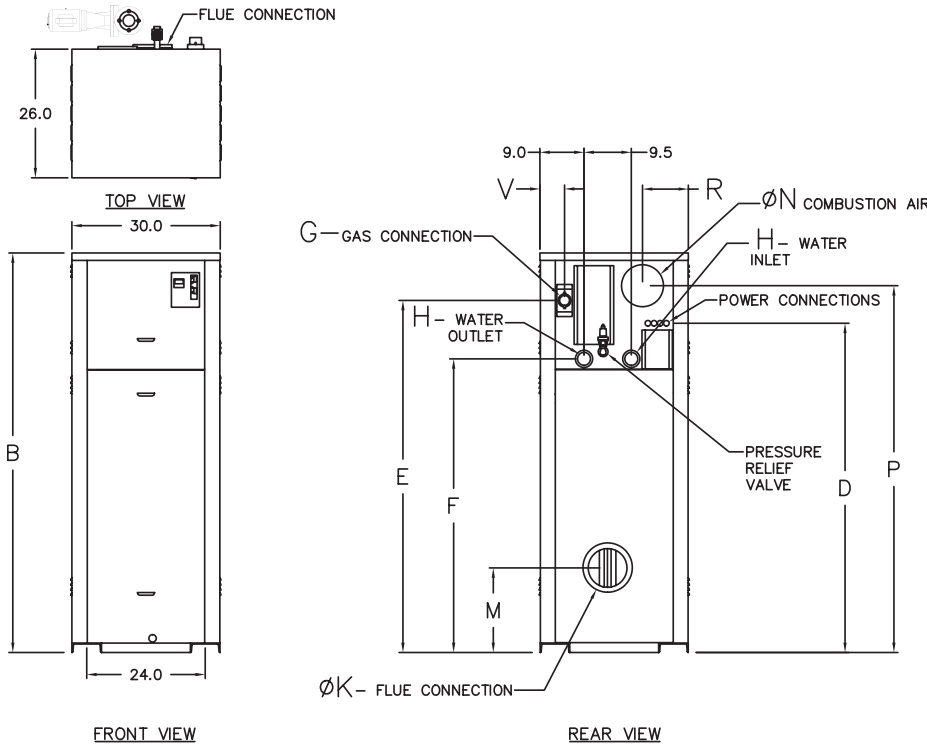

CLEARANCES

	Certified Minimum	Recomm. Service
Front	24"	24"
Rear	12"	24"
Right	1"	–
Left	1"	–
Top	0"	10"
Floor	0"	–
Vent	1"	–

PUMP

Model	Pump		
	Model	HP	Amps*
P-504	1611	¼	6
P-754	1630	½	7
P-1104	1630	½	7
P-1504	1634	1	14
WHP-2004	1636	1 ½	22

* Current draw is for pump only

Shown without H-bypass or Cold Water Run options

Model	MBTUH		Dimensions (in.)											Ship Weight (Lbs.)	Foot-print (Ft ²)	Amps*	
	Input	Output	B Height	D	E	F	G NPT	H NPT	K Flue Ø	M	N C/A Ø	P	R				V
P-504	500	420	43	30	35	23-3/4	1	2	8	14-1/8	6	36	8	2	600	5.4	12
P-754	750	630	49	36	41	29-3/4	1	2	10	16	6	42	8	2	660	5.4	12
P-1104	1100	935	55	43	47	35-3/4	1-1/4	2-1/2	10	16	6	49	8	2	720	5.4	12
P-1504	1500	1275	61	50	53	41-3/4	1-1/4	2-1/2	12	18-1/8	8	53	8	2	780	5.4	12
WHP-2004	1900	1615	75	61	65	53-3/4	2	2-1/2	14	20-1/8	8	69	9	5	940	5.4	18

- Ratings shown are for elevations up to 4,500 feet. For installations at elevations above 4,500 feet, please consult the factory for additional instructions.

* Current draw is for heater only. (Supply breaker must have delayed trip.)

Model	RATES OF FLOW							
	20°F ΔT		Minimum Flow			Maximum Flow		
	GPM	ΔP (ft.)	GPM	ΔP (ft.)	ΔT (°F)	GPM	ΔP (ft.)	ΔT (°F)
P-504	N/A	N/A	65	5.5	13	100	11.3	9
P-754	65	6.4	65	6.4	20	100	13.8	13
P-1104	94	13.6	85	11.5	22	113	18.6	17
P-1504	N/A	N/A	102	18.7	25	113	22.2	23
WHP-2004	N/A	N/A	102	22.7	32	113	27.2	29