

WARNING: If the information in these instructions are not followed exactly, a fire or explosion may result causing property damage, personal injury or death.

- Do not store or use gasoline or other flammable vapors and liquids in the vicinity of this or any other appliance.
- **WHAT TO DO IF YOU SMELL GAS**
 - Do not try to light any appliance.
 - Do not touch any electrical switch; do not use any phone in your building.
 - Immediately call your gas supplier from a neighbor's phone. Follow the gas supplier's instructions.
 - If you cannot reach your gas supplier, call the fire department.
- Installation and service must be performed by a qualified installer, service agency or the gas supplier.

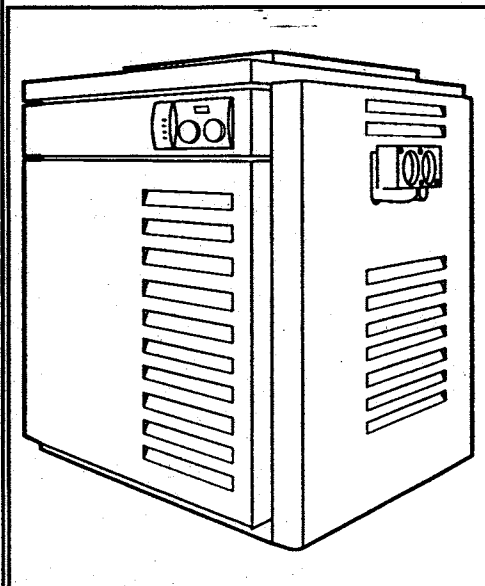

**Operating, Installation
and Servicing Instructions
for**

RP 2100

Swimming Pool & Spa Heater

Model R185 - R405

Raypak[®]

TO WHOM IT MAY CONCERN:

The new Raypak series RP2100 pool heaters have been designed to eliminate the need for conventional heat sinks (high temperature piping). The initial connection to the heater is made with a 2" MXS CPVC adapter to which PVC may then be connected with appropriate cement. The 2" CPVC adapter will be provided with the heater by Raypak.

This newly authorized piping arrangement is described in the installation manual provided by Raypak, and has been successfully tested by Raypak to assure its acceptability.



Larry J. Ashton, P.E.
Vice President of Engineering
and Technical Services



CONTENTS

2	PART ONE - OWNER'S OPERATING INSTRUCTIONS
2	SECTION 1 / START-UP PROCEDURES
2	Before Start-Up
3	Lighting Instructions & Shut-Off Procedure (Manually Lighted Pilot MV)
4	Operating Instruction & Shut-Off Procedures (Automatically Lighted Pilot IID)
5	After Start-Up
5	SECTION 2 / CAUTION
5	SECTION 3 / MAINTENANCE & CARE PROCEDURE
6	Pool & Spa Water Chemistry
6	Cold Weather Operation
6	Winterizing the Pool & Spa Heater
7	PART TWO - INSTALLATION/SERVICE INSTRUCTIONS
7	SECTION 1/RECEIVING EQUIPMENT
7	SECTION 2/GENERAL SPECIFICATIONS
8	SECTION 3/INSTALLATION INSTRUCTIONS
11	Indoor Heater
11	Combustion Air
12	Gas Supply Connections
13	Plumbing For Water Connections
14	Left Side water connection Conversion
17	Electrical Wiring
21	SECTION 4/SERVICING INSTRUCTIONS
21	General Location of Controls
21	Control Adjustments/Replacements
23	Pressure Switch
23	High Limit
23	Pilot Safety
24	Burner Drawer Removal
24	Gas Valve Removal
24	Main Burner & Orifice Removal
24	Pilot Removal & Cleaning
24	Heat Exchanger Removal
25	Tube Cleaning/Replacement
25	Desooting Procedure
26	Combustion Chamber Removal
26	Control Immersion Well Replacement
26	Unitherm Governor Replacement
27	SECTION 5/TROUBLE SHOOTING GUIDE
27	Mechanical
28	Electrical MV Units
29	Electrical IID Units
32	SECTION 6/REPLACEMENT PARTS

PART ONE - OWNER'S OPERATING INSTRUCTIONS

FOR YOUR SAFETY - READ BEFORE OPERATING

WARNING: IF YOU DO NOT FOLLOW THESE INSTRUCTIONS EXACTLY, A FIRE OR EXPLOSION MAY RESULT, CAUSING PROPERTY DAMAGE, PERSONAL INJURY OR LOSS OF LIFE.

SECTION 1 / START-UP PROCEDURES

BEFORE START-UP

BURNERS

Clean main burners and air louvers of dust, lint and debris. Keep heater area clear and free from combustibles, flammable liquids and chemicals. Do not obstruct the flow of combustion and ventilating air.

WATER

Water must be flowing through the heater during operation. Insure that system is filled with water and have pump operating.

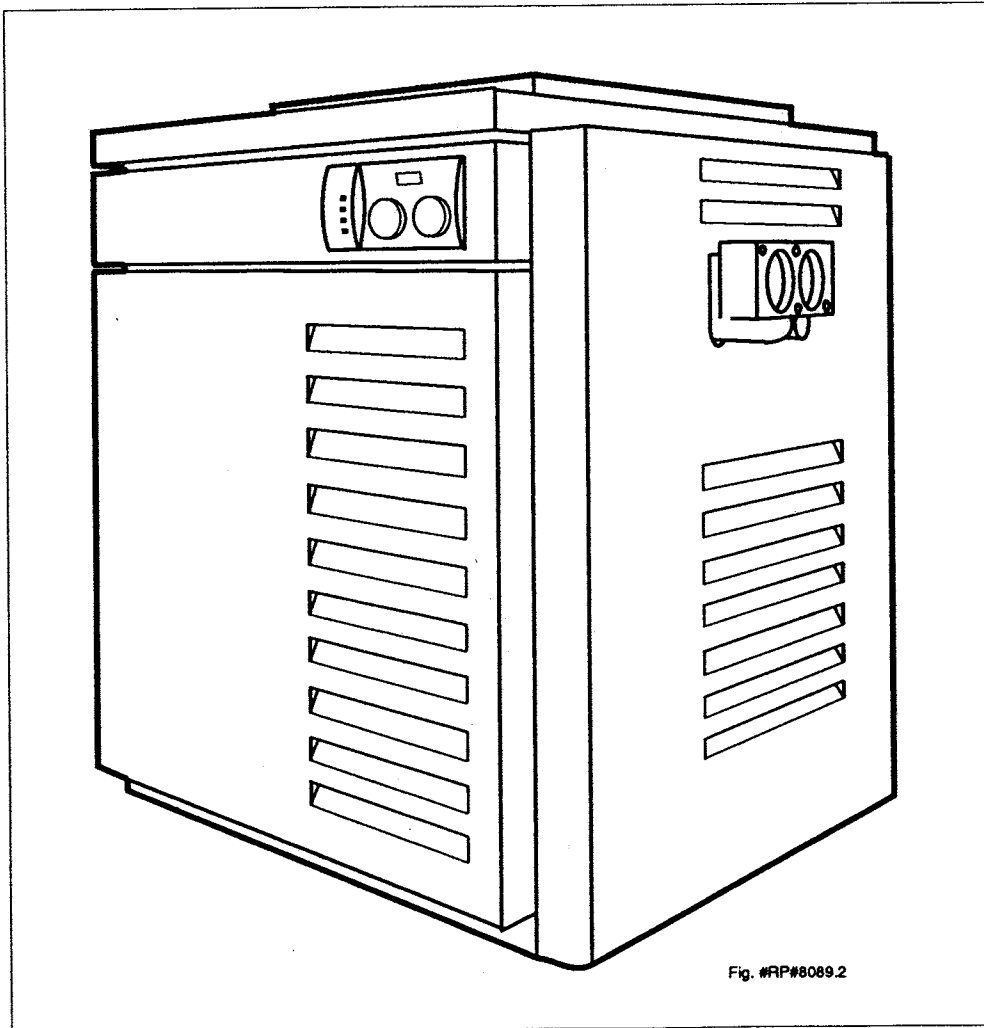

CAUTION: Propane gas is heavier than air and will settle on the ground. Since propane can accumulate in confined areas, extra care should be exercised when lighting propane heaters.

LIGHTING INSTRUCTIONS AND SHUT-OFF PROCEDURES

**MANUALLY LIGHTED PILOTS
MILLIVOLT SYSTEM**

- A. This appliance has a pilot that must be lighted by hand. When lighting the pilot, follow these instructions exactly.
- B. BEFORE LIGHTING smell all around the appliance area for gas. Be sure to smell next to the floor because some gas is heavier than air and will settle on the floor.

WHAT TO DO IF YOU SMELL GAS:

- *Do not try to light any appliance.
- *Do not touch any electric switch; do not use any phone in your building.
- *Immediately call your gas supplier from a neighbor's phone. Follow the gas supplier's instructions.

- *If you cannot reach your gas supplier, call the fire department.
- C. Use only your hand to push in or turn the gas control knob. Never use tools. If the knob will not push in or turn by hand, do not try to repair it. Call a qualified service technician. Force or attempted repair may result in a fire or explosion.
- D. Do not use this appliance if any part has been underwater. Immediately call a qualified service technician to inspect the appliance and to replace any part of the control system and any gas control which has been underwater.

LIGHTING INSTRUCTIONS

1. **STOP!** Read the safety information above.
 2. Set the thermostat on the lowest setting.
 3. Turn On/Off switch to the "Off" position.
 4. Remove heater door panel.
 5. Push in gas control knob slightly and turn clockwise  to "Off".
- NOTE:** Knob cannot be turned from "Pilot" to "Off" unless knob is pushed in slightly. Do not force.
6. Wait 5 minutes to clear out any gas. If you then smell gas, **STOP!** Follow "B" in the safety information above. If you don't smell gas, go to the next step.
 7. Locate pilot mounted on the right side panel of the burner drawer. For burner drawer location, see location of control section, page 20.

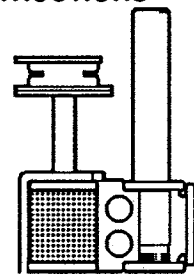

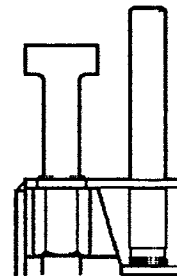

HONEYWELL PILOT

Fig. # 8083.0



ROBERTSHAW PILOT

Fig. # 8084.1

8. Turn knob on gas control counter-clockwise  to "Pilot"
9. Place flame end of pilot tube. Push in control knob all the way and hold to light pilot. Continue to hold control knob in for about one minute after the pilot is lighted, release knob and it will pop back up. Pilot should remain lighted. If it goes out, repeat steps 5 through 9. *If knob does not pop up when released, stop and immediately call your service technician or gas supplier.
10. Stand to the side of the heater and turn the gas control knob counter-clockwise to  "On".
11. Replace heater door panel.
12. Turn On/Off switch to the "On" position.
13. Set thermostat to the desired setting.

GAS CONTROL KNOB SHOWN IN OFF POSITION

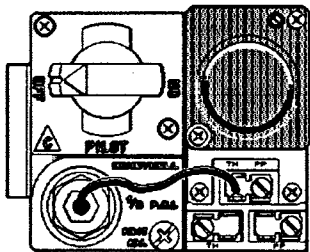

HONEYWELL
GAS VALVE
MILLIVOLT

Fig. # 8081.0

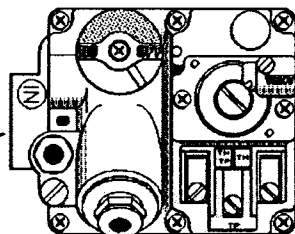

ROBERTSHAW
GAS VALVE
MILLIVOLT

Fig. # 8079.0

TO TURN OFF GAS TO APPLIANCE

1. Set the thermostat to the lowest setting.
2. Turn On/Off switch to the "Off" position.
3. Remove heater door panel.
4. Push the gas control knob slightly and turn clockwise to  "Off". Do not force.
5. Replace heater door panel.

CAUTION: Propane gas is heavier than air and will settle on the ground. Since propane can accumulate in confined areas, extra care should be exercised when lighting propane heaters.

**OPERATING INSTRUCTIONS AND SHUT-OFF PROCEDURES
AUTOMATICALLY LIGHTED PILOTS
ELECTRONIC IGNITIONS SYSTEMS**

- A. This appliance is equipped with an ignition device which automatically lights the pilot. Do not try to light the pilot by hand.
- B. **BEFORE OPERATING**, smell all around the appliance area for gas. Be sure to smell next to the floor because some gas is heavier than air and will settle on the floor.

WHAT TO DO IF YOU SMELL GAS:





- *Do not try to light any appliance.
- *Do not touch any electric switch; do not use any phone in your building
- *Immediately call your gas supplier from a neighbor's phone. Follow the gas supplier's instructions.

*If you cannot reach your gas supplier, call the fire department.

C. Use only your hand to push in or turn the gas control knob. Never use tools. If the knob will not push in or turn by hand, don't try to repair it; call a qualified service technician. Force or attempted repair may result in fire or explosion.

D. Do not use this appliance if any part has been underwater. Immediately call a qualified service technician to inspect the appliance and to replace any part of the control system and any gas control which has been underwater.

OPERATING INSTRUCTIONS

1. **STOP!** Read the safety information above.
2. Set the thermostat to the lowest setting.
3. Turn off all electric power to the appliance.
4. This appliance is equipped with an ignition device which automatically lights the pilot. Do not try to light the pilot by hand.
5. Remove heater door panel.
6. **For Honeywell Valve:** Turn gas control knob clockwise  to "Off".
For Robertshaw valve: Turn gas control knob clockwise  to "Off". (Models 265-405) Push in and move gas control lever counter-clockwise  to "Off" position. (Model 185)
7. Wait 5 minutes to clear out any gas. If you then smell gas **STOP!** Follow "B" in the safety information previously stated. If you don't smell gas, go to the next step.
8. Turn gas control knob counter-clockwise  to "On". (Honeywell VR 8300 and Robertshaw 7000)
9. Replace heater door panel.
10. Turn on all electric power to the appliance.
11. Set thermostat to desired setting.
12. If the appliance will not operate, follow the instructions "To Turn Off Gas To Appliance" and call your service technician or gas supplier.

GAS CONTROL KNOB SHOWN IN "ON" POSITION

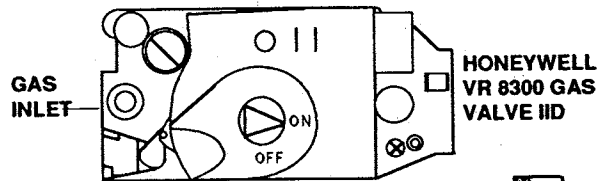

ROBERTSHAW 7000 GAS VALVE IID MODEL 265-405

Fig. # 8080.0

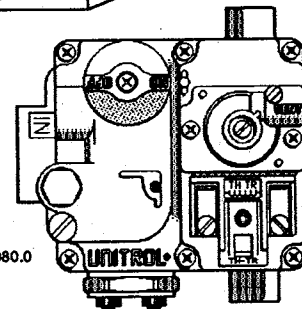

GAS CONTROL LEVER SHOWN IN "OFF" POSITION

GAS INLET

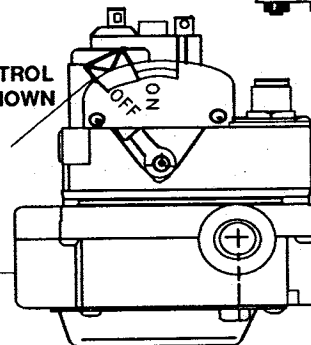

ROBERTSHAW 7200 GAS VALVE IID MODEL 185

TO TURN OFF GAS TO APPLIANCE

1. Set the thermostat at the lowest setting.
2. Turn off all the electric power to the appliance if service is to be performed.
3. Remove heater door panel.
4. **For Honeywell VR 8300 and Robertshaw 7000 gas valve.** Turn gas control knob clockwise 

to "Off". Make sure knob rest against stop.
For Robertshaw 7200 gas valve.

- Push in and move gas control lever counter-clockwise  to "Off" position.
5. Replace heater door panel.

AFTER START-UP

Feel the inlet and outlet pipes. Outlet pipe should be only slightly warmer than the inlet. It should not be hot.

WARNING: Should overheating occur or the gas supply fail to shut off, turn off the manual gas control to the appliance.

VISUAL INSPECTION

With the heater on, remove the door and make a visual check of the pilot and burner.

The flame should be blue with a well-defined pattern.

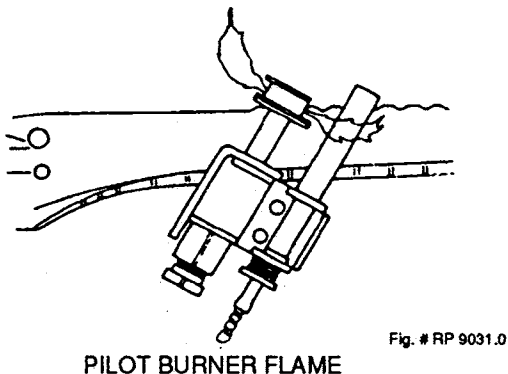
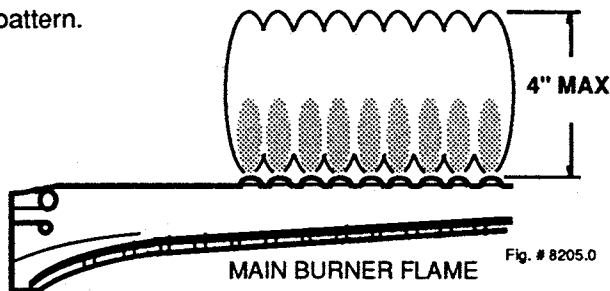

A yellow or "floating" flame indicates restricted air openings or incorrect orifice size. Should this occur, shut the heater off and contact your installer or gas supplier.

WATER PRESSURE SWITCH

A water pressure switch is provided in the heater to shut off the burners in the event that water supply to the heater is interrupted. It is very important to verify that the switch electrically opens and shuts off the gas valve when water flow to the heater is interrupted. Otherwise, rapid and severe damage will likely occur to the heater. (The water pressure switch should be checked and adjusted for proper operation by a qualified service person at the time of installation and periodically checked thereafter. Refer to pressure switch servicing instruction in Section 4 of this manual).

WARNING: Operation of the heater without water circulation will cause rapid and severe damage to the heater.

SECTION 2/CAUTION

Elevated water temperature can be hazardous, and the U. S. Consumer Product Safety Commission recommends the following guidelines:

1. Spa or hot tub water temperatures should never exceed 104°F (40°C). A temperature of 100°F (38°C) is considered safe for a healthy adult. Special caution is suggested for young children.
2. Drinking of alcoholic beverages before or during spa or hot tub use can cause drowsiness which could lead to unconsciousness and subsequently result in drowning.
3. *Pregnant Women Beware!* Soaking in water over 102°F (39°C) can cause fetal damage during the first three months of pregnancy resulting in the birth of a brain-damaged or deformed child. Pregnant women should stick to the 100°F (38°C) maximum rule.
4. Before entering the spa or hot tub, users should check the water temperature with an accurate thermometer; spa or hot tub thermostats may err in regulating water temperatures by as much as 4°F (2.2°C).
5. Persons with a medical history of heart disease, circulatory problems, diabetes, or blood pressure problems should obtain a physician's advice before using pools or hot tubs.
6. Persons taking medications which induce drowsiness, such as tranquilizers, antihistamines, or anticoagulant, should not use spas or hot tubs.

SECTION 3/MAINTENANCE AND CARE PROCEDURES

To be followed one month after start-up and then semi-annually.

1. Inspect top of heater and draft hood for soot, (a sticky black substance around finned tubes and "V" baffles), and open flue gas passage ways.

CAUTION: Soot may be combustible. Wet sooted surfaces completely prior to cleaning. Do not use steel wire brush.

2. Clean main burners and pilot burner of dust and lint.
3. Inspect and operate all controls, gas valve and pressure relief valve.

4. Make visual check of the burner and pilot flame. Flame pattern on the main burner and pilot is indicated in the previous illustration. Yellow flame means restriction of the air openings. Lifting or blowing flame indicates high gas pressure. Low flame means low gas pressure. Should this occur, shut the heater off and contact your gas supplier or qualified service agency.
5. On indoor heaters, clean room intake openings to assure adequate flow of combustion and ventilation air.

CAUTION: Combustion air must not be contaminated by corrosive chemical fumes which can damage the heater and void the warranty.

6. Keep area around heater clear and free from combustible materials, gasoline and other flammable and corrosive vapors and liquids.

POOL & SPA WATER CHEMISTRY

Chemical imbalance can cause severe damage to your heater and associated equipment. Maintain your water pH between 7.4 and 7.8 and total alkalinity between 100 and 150 p.p.m. If the mineral content and dissolved solids in the water become too high, scale forms inside the heat exchanger tubes, reducing heater efficiency and also damaging the heater. If the pH drops below 7.2, the heater will be severely damaged. This will result in corrosion of the heat exchanger. **Heat exchanger damage resulting from chemical imbalance is not covered by the warranty.**

AUTOMATIC CHLORINATORS AND CHEMICAL FEEDERS

All chemicals must be introduced and completely diluted into the pool or spa water before being circulated through the heater. Do not place chlorine tablets or bromine sticks in the skimmer. High chemical concentrations will result when the pump is not running (i.e. overnight).

Chlorinators must feed downstream of the heater and have an anti-siphoning device to prevent chemical back-up into the heater when the pump is shut off.

NOTE: High chemical concentrates from feeders and chlorinators that are out of adjustment will cause very rapid corrosion to the heat exchanger in the heaters. Such damage is not covered under the warranty.

COLD WEATHER OPERATION

MODERATE CLIMATE: Heater operation can continue during short term cold spells. When temperatures are below freezing, flow (continuous pump operation) must be maintained.

CAUTION: Do not use the heater to maintain water temperatures just above freezing or for freeze protection. When heater is used during freezing weather, care must be taken to avoid freeze ups. Continuous pump operation is a must. Additional protection may be required. The heater is not warranted against freeze ups.

COLD CLIMATE: Prolonged operation with water temperatures below 50°F is not recommended. When starting the heater with pool temperatures below 50°F operate the heater continuously until higher temperatures are reached. Operating the heater for prolonged periods with pool water below 50°F can seriously damage the heater, and is not covered by the warranty.

For cold climate areas, please follow the winterizing procedures listed.

WINTERIZING THE POOL & SPA HEATER

When heaters installed outdoors in freezing climate areas are to be shut down for the winter, observe the following step-by-step procedure:

1. Turn off gas valve, manual gas valve, and electrical supply to the heater.
2. Open drain cock located on the inlet/outlet header, (under water pipes). Remove drain plug from return header. Remove the heat exchanger inspection panels on the side opposite water piping to gain access to the plug on the return header.

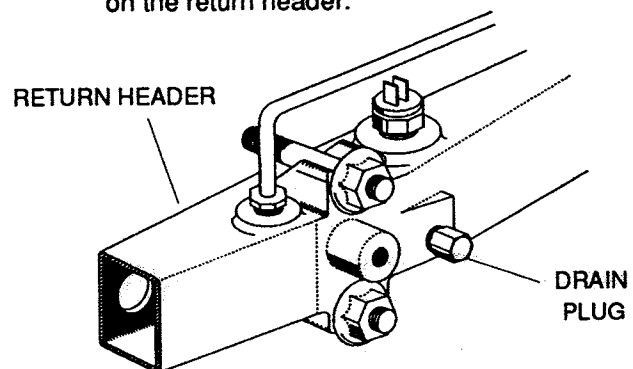

Fig. #RP 8094.0

3. Disconnect compression fittings from the pressure switch and return header that connects to the 1/4" copper tube and allow the tube to drain.

PART 2 - INSTALLATION/SERVICE INSTRUCTION

SECTION 1 / RECEIVING EQUIPMENT

On receipt of your equipment it is suggested that you visually check for external damage to the carton. If the carton is damaged, a note should be made on the Bill of Lading when signing for equipment. Remove the heater from the carton and if it is damaged, report the damage to the carrier immediately. Save the carton.

These items are shipped loose inside the carton with the heater:

1. "Pagoda" Top
2. In/Out Flanges (2)
3. 1-1/2" Flange Gaskets (2)
4. 2" Flange Gaskets (2)
5. Flange Bolts (4)
6. PRV (ASME Units Only)
7. 2" CPVC Adapters (2)
8. Plastic pipe finish flange for gas line.
9. Bonding lug with mounting screw. (IID units only).

Be sure that you receive the number of packages indicated on the Bill of Lading.

When ordering parts, you must specify model and serial number of heater. When ordering under warranty conditions, you must also specify date of installation.

Raypak recommends that this manual be reviewed thoroughly before installing your Raypak pool/spa heater. If there are any questions that this manual does not answer, please contact the factory or your local Raypak representative.

SECTION 2 / GENERAL SPECIFICATIONS

All heaters are inter-changeable and can be used either indoor or outdoors. The appropriate top designated for that type of use is required. If desired, the top can be changed at a later date to change from outdoor to indoor or vice versa. Millivolt heater contain a self-generating electrical system operating between .25 and .75 volts.

Ambient Temperature Rating of Heater Components

Millivolt Heater with Honeywell Gas Valve +32°F to +175°F

Millivolt Heater with Robertshaw Gas Valve 0°F to +175°F

Electronic Ignition Heaters* -32°F to + 175°F

*Requires 120V or 240V Power Supply

Rated inputs suitable for up to 2000 feet elevation. For elevations above 2000 feet, reduce input 4% for each 1000 feet above sea level, as high elevation reduces combustion performance.

SECTION 3 / INSTALLATION INSTRUCTIONS

IMPORTANT NOTICE

These instructions are intended for the use of qualified personnel only, specifically trained and experienced in the installation of this type of heating equipment and related system components. Installation and service personnel may be required by some states to be licensed. If your state is such, be sure your contractor bears the appropriate license. Persons not qualified shall not attempt to fix this equipment nor attempt repairs according to these instructions.

WARNING:

Improper installation, adjustment, alteration, service or maintenance may damage the equipment, create a hazard resulting in asphyxiation, explosion or fire, and will void the warranty.

CODE REQUIREMENTS

NOTE: *The heater should not be located in an area where possible water leakage will result in damage to the area adjacent to the appliance or to the structure. When such locations cannot be avoided, it is recommended that a suitable drain pan, adequately drained, be installed under the appliance. The pan must not restrict combustion air flow.*

Installation must be in accordance with local codes, or, in the absence of local codes, with the latest edition of the National Fuel Gas Code, ANSI Z223.1 and National Electrical Code, ANSI/NFPA 70.

BASE INSTALLATION

Heater must be mounted on a level base, such as cement slab, cement blocks or other non-combustible surface. An optional non-combustible base is available for all models. An alternative method for providing a base for combustible floors is illustrated above. Heaters must **not** be installed on carpeting.

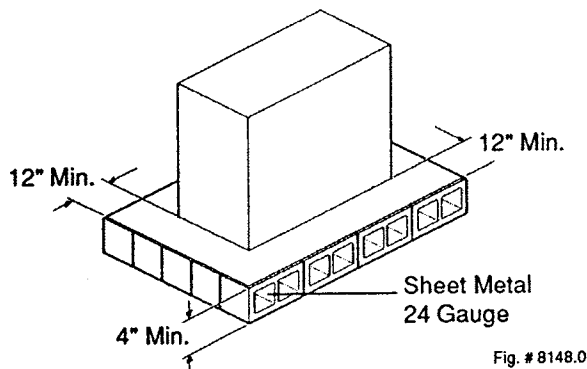

Hollow concrete cinder block, align holes and leave ends open. Alternative method for providing a non-combustible base.

CLEARANCES

ALL HEATERS

For clearances from combustible surfaces, see the chart below.

CLEARANCE FROM COMBUSTIBLE CONSTRUCTION	
INDOOR INSTALLATIONS:	
Top* (Drafthood)- 30"	Back - 6"
Front - Alcove	Right Side-(Water Side) 12"
Vent - 6"	Left Side-(Opposite Water side) 6"
OUTDOOR INSTALLATION:	
Top* (Stackless top or outdoor stack) - Unobstructed	
Back - 6"	
Side - 6"	

*Clearance from top of vent terminal.

For servicing, provide at least 24" in front of the heater for burner tray removal, and at least 18" on water connection side of the heater to inspect and delime the heat exchanger.

OUTDOOR HEATERS

These heaters are designed certified by A.G. A. for outdoor installation, when equipped with the approved tops designated for outdoor use.

WARNING: The heater shall not be located in an area where water sprinklers, or other devices, may cause water to spray through the cabinet louvers and into the heater. This could cause heavy internal rusting or damage some electrical components, and this would void the warranty.

WARNING: Do not install within 3 feet of a Heat Pump or an outdoor condensing unit. Strong air intake from these equipment can disturb the combustion process and cause damage or personal injury.

HEATER WITH OUTDOOR STACKLESS TOP

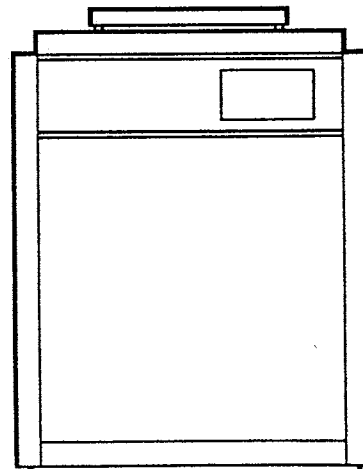

Fig. #RP 8278

VENT TERMINAL (Outdoor) Stackless Top Installation

1. Insert tabs into keyhole (4 places).

2. Snap tabs into keyholes so as not to pull out.

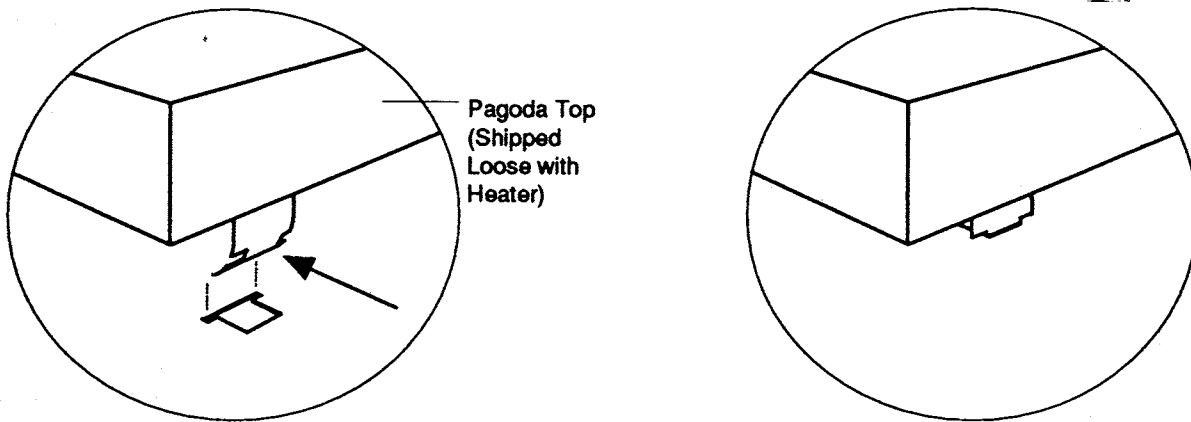
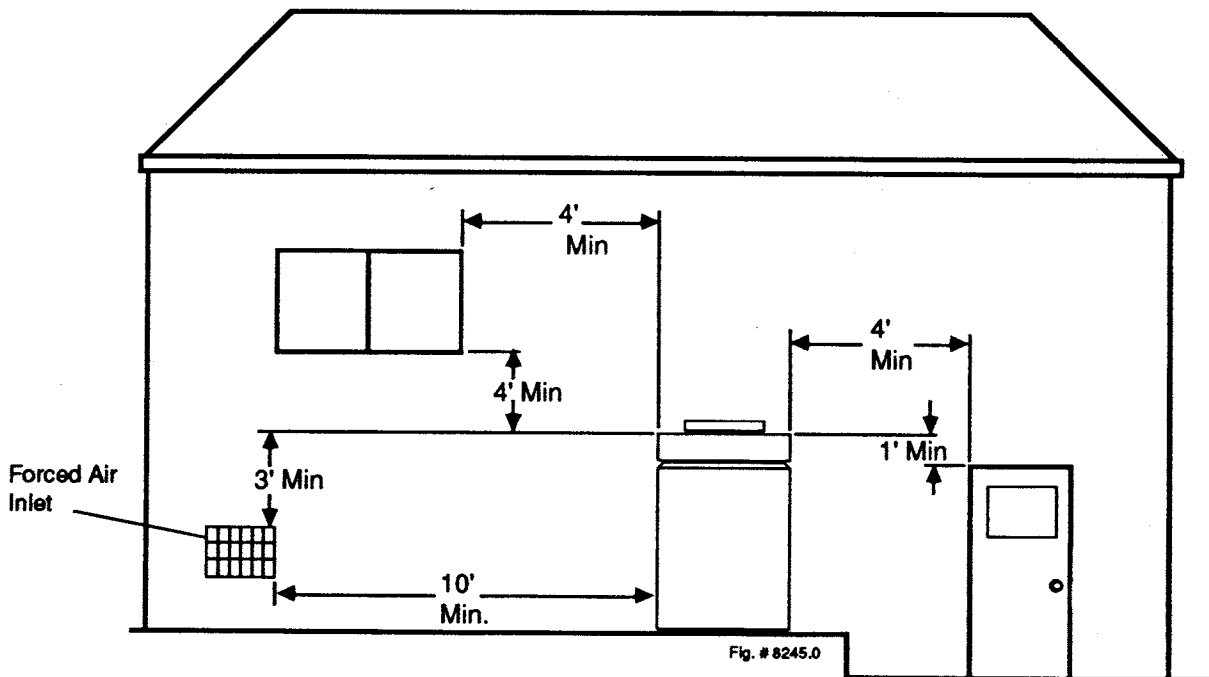

Fig. #RP8280.1

Heaters must not be installed under an overhang of less than three (3) feet from the top of the heater. Three (3) sides must be open in the area under the overhang. Roof water drainage must be diverted away from the heaters installed under overhangs with the use of gutters:

The point from where the flue products exit the heater must be a minimum of four (4) feet below, four (4) feet horizontally from or one (1) foot above any door, window or gravity inlet to a building. The top surface of the heater shall be at least three (3) feet above any forced air inlet, or intake ducts located within ten (10) feet horizontally.



INDOOR HEATER

The design is also certified by A.G.A. for indoor installation when equipped with the approved draft hood. Locate heater as close as practical to a chimney or gas vent. Heater must always be vented to the outside. See Vent Piping Section for venting details. Minimum allowable space is shown on the nameplate.

VENT TERMINAL/INDOOR STACK INSTALLATION

1. Remove the louvered jacket top by removing four (4) #10 flat head screws.
2. If originally installed, remove "Pagoda" top from the louvered jacket top.
3. Place the inner stack adapter panel over the flue collector inside the heater. Make sure the flanged side of the flue opening is up.
4. Turn the stack (draft hood) up side down and set it down bottom side up.
5. Turn the jacket top panel (removed in step 1) down and place it through the stack.
6. Attach the three (3) mounting brackets to the stack using the screws provided and the holes that are pre-drilled in the stack. **Make sure the brackets are positioned with the flange near the top side of the stack (see illustration below).** *Caution must be taken not to over tighten and strip the screw threads.*
7. Turn the assembled stack and jacket top, right side up. The jacket top will be trapped between the brackets and the top of the stack. Place the stack over the inner adapter panel flanged hole and lower the louvered jacket top panel back into its original position. Reinstall the four (4) green #10 flat head screws removed in step 1 above.

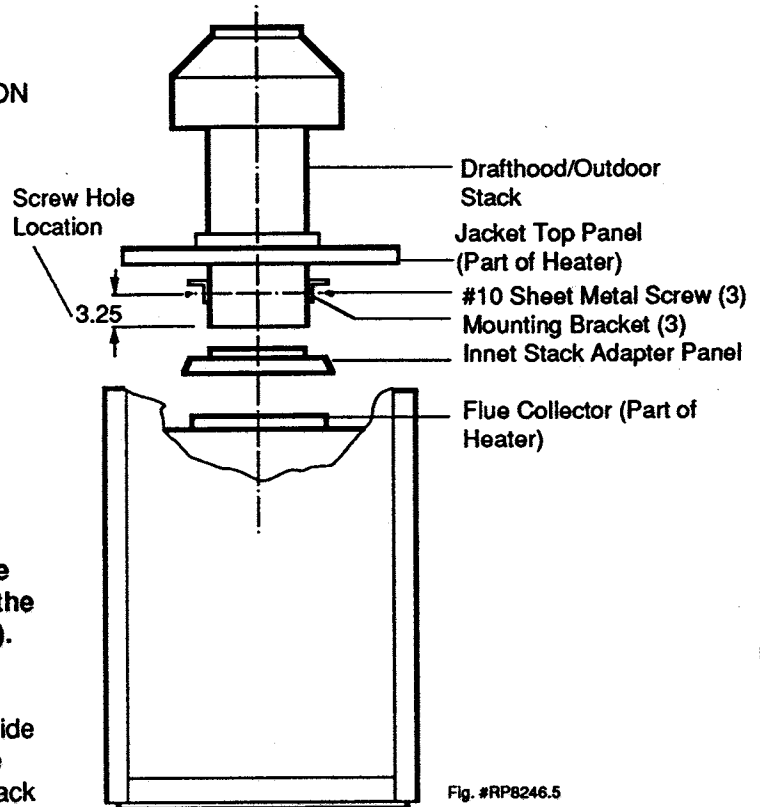

SPECIFICATIONS AND DIMENSIONS

Model	Btu Input (000)	(A) Cabinet Width	(B) Flue Dia.	Single or Dual		Water Connects.		Shipping Weights (lbs)	
				Temp. Controls Milli-volts	Electronic Ignition	1-1/2"	2"	Indoor Draft Hood	
R-185	181	18-1/4"	7"	S	D	√	√	191	12
R-265	264	22-3/8"	8"	S	D	√	√	214	15
R-335	333	25-3/4"	9"	S	D	√	√	234	17
R-405	399	29-1/4"	10"	S	D	√	√	253	20

Above input ratings are per A.G.A. specifications. Reduce input 4% for each 1000 ft. above sea level when installed above 2000 ft. elevation. Manufactured under Patent No. 3,623,458.

MODELS R185 THROUGH R405

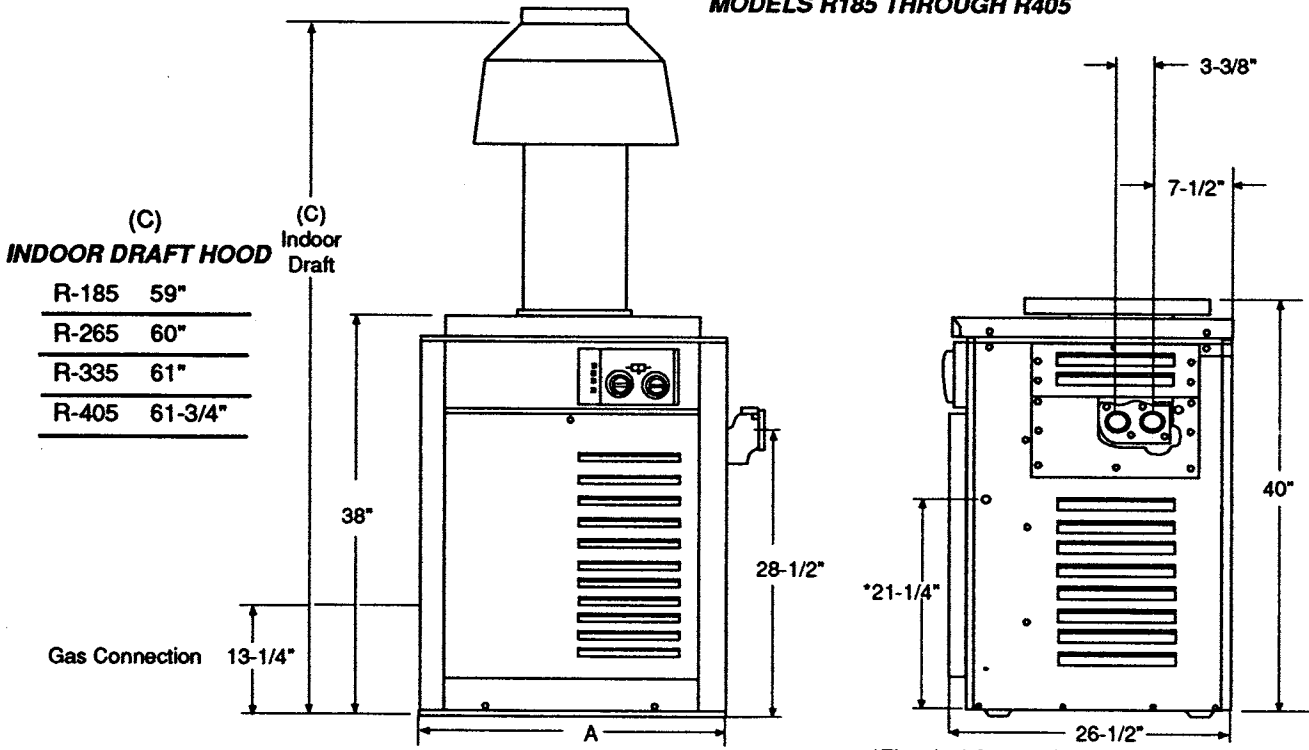

(C) INDOOR DRAFT HOOD

R-185	59"
R-265	60"
R-335	61"
R-405	61-3/4"

Fig.#RP9037

COMBUSTION AIR (Indoor Units Only)
Air For Combustion And Ventilation (Indoor Units Only)

The heater must have both combustion and ventilation air. Minimum requirements for net free air supply openings, one 12 inches from ceiling for ventilation and one 12 inches from the floor for combustion air as outlined in the latest edition of the National Fuel Gas Code, ANSI Z2231 and any local codes that may have jurisdiction.

CAUTION: Combustion air must not be contaminated by corrosive chemical fumes which can damage the heater and void the warranty.

a. All Air From Inside The Building:
Each opening shall have a minimum net free square inches as noted:

Model	Square Inches	Model	Square Inches
185	181	335	333
265	264	405	399

b. All Air From Outdoors:
When air is supplied directly from outside of building, each opening shall have a minimum net free square inches as noted:

Model	Square Inches
185	46
265	66
335	84
405	100

WARNING:

Indoor boilers require a draft hood that must be connected to a vent pipe and properly vented to the outside. Failure to follow this procedure can cause fire or fatal carbon monoxide poisoning.

Vent piping the same size or larger than the draft hood outlet is recommended, however, when the total vent height is at least ten (10) feet (draft hood relief opening to vent terminal), the vent pipe size may be reduced as specified in Part 11 of the National Fuel Gas Code, ANSI Z 223.1. As much as possible avoid horizontal runs of vent pipe and too many elbows. If installation requires horizontal runs, the vent pipe must have a minimum of 1/4 inch per foot rise and should be supported at not less than five foot intervals. Plumbers tape, criss-crossed, will serve to space both horizontal and vertical piping. Gas vents supported only by the flashing and extending above the roof more than five feet should be securely guyed or braced to withstand snow and wind loads. We recommend use of insulated vent pipe spacer through the roofs and walls.

For protection against rain or blockage by snow, the vent pipe must terminate with a vent cap which complies with the local codes or, in the absence of such codes, to the latest edition of the National Fuel Gas Code, ANSI Z223.1.

The discharge opening must be a minimum of two feet vertically from the roof surface and at least two feet higher than any part of the building within ten feet. Vent stack shall be at least five feet in vertical height above the draft hood outlet. The vent cap location shall have a minimum clearance of 4 feet horizontally from, and in no case below, unless a 4-foot horizontal distance is maintained, from electric meters, gas meters regulators and relief equipment.

The weight of the vent stack or chimney must not rest on heater draft hood. Support must be provided in compliance with applicable codes. The heater top and draft hood must be readily removable for maintenance and inspection. Vent pipe should be adequately supported to maintain proper clearances from combustible construction.

Type "B" double wall or equivalent vent pipe is recommended. However single wall metal vent pipe may be used as specified in the latest edition of the National Flue Gas Code ANSI Z 223.1.

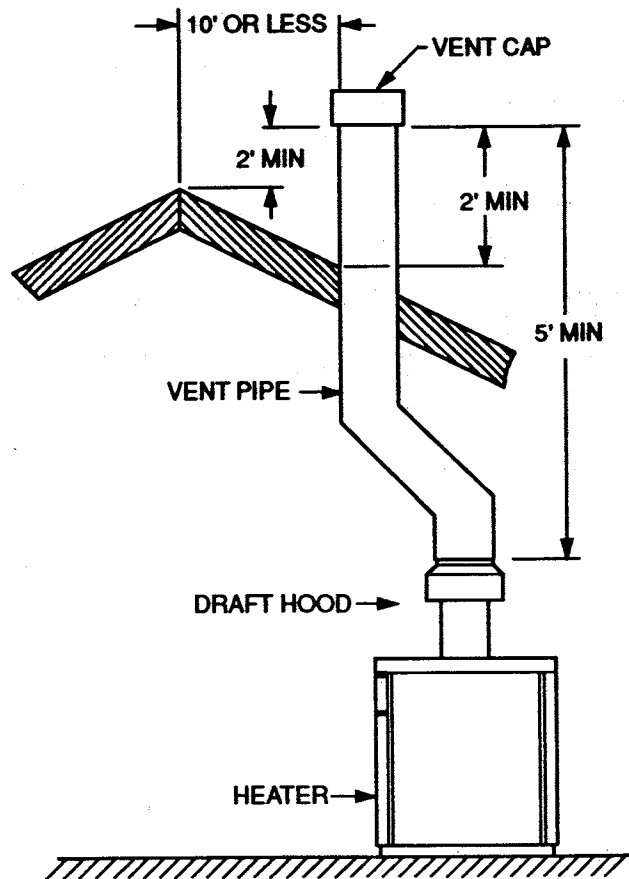

GAS SUPPLY CONNECTIONS

Fig. #RP 8119.1

Gas piping must have a sediment trap ahead of the heater gas controls, and a manual shut-off valve located outside the heater jacket. All gas piping should be tested after installation in accordance with local codes.

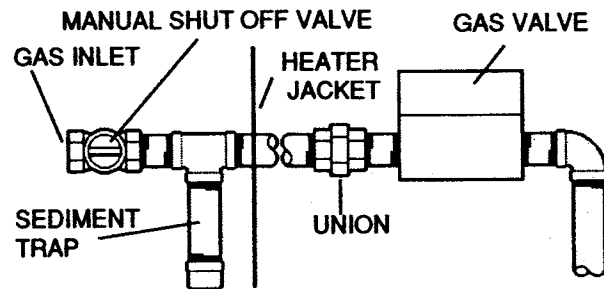



Fig. # 8090.0

CAUTION: The heater and its manual shut off valve must be disconnected from the gas supply during any pressure testing of that system at test pressures in excess of 1/2 psig (3.45 KPA). Dissipate test pressure in the gas supply line before reconnecting the heater and its manual shut off valve to gas supply line. FAILURE TO FOLLOW THIS PROCEDURE MAY DAMAGE THE GAS VALVE. OVER PRESSURED GAS VALVES ARE NOT COVERED BY WARRANTY. The heater and its gas connections shall be leak tested before placing the appliance in operation. Use soapy water for leak test. DO NOT use open flame.

NOTE: Do not use teflon tape on gas line pipe thread. A flexible sealant is recommended.

A minimum of 7" W.C. and a maximum of 14" W.C. upstream pressure under load, and no load conditions must be provided for natural gas or a minimum of 12" W.C. and a maximum of 14" for propane gas.

GAS PRESSURE REGULATOR

The gas pressure regulator is preset and sealed at 4" W.C. for natural gas, and 11" W.C. for propane gas. Between the gas valve and the burners is a 1/8" pipe plug. The pressure at this point, taken with a manometer, should be about 3.7" W.C. natural gas and 10.5" W.C. propane gas. If an adjustment is needed, remove seal and turn adjustment screw clockwise  to increase pressure or counter-clockwise  to decrease pressure.

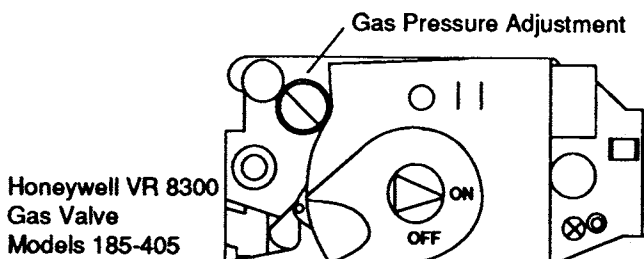
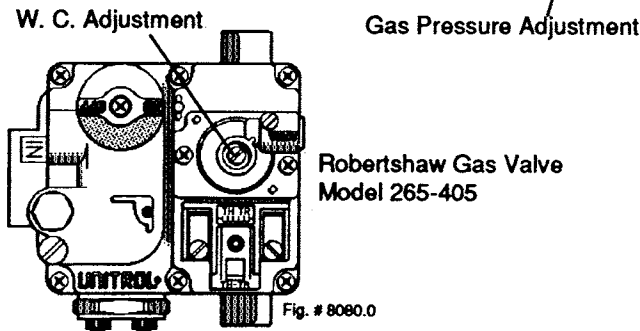
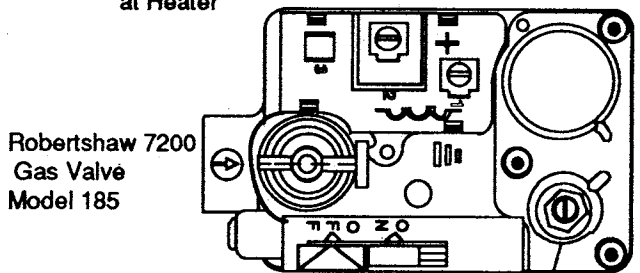
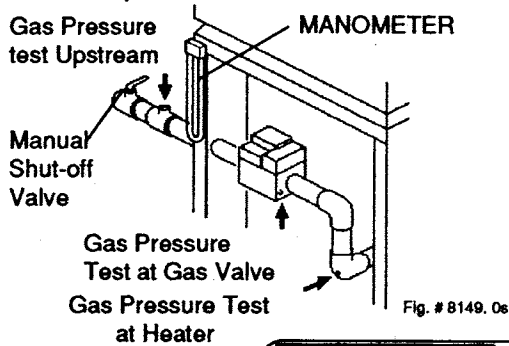

PIPE SIZING FOR GAS CONNECTIONS MAXIMUM EQUIVALENT PIPE LENGTH

Natural Gas 1000 BTU/FT ³ .60 Specific Gravity @ 0.5" WC Pressure Drop										
Propane Gas 2500 BTU/FT ³ 1.53 Specific Gravity @ 0.5" WC Pressure Drop										
Model	1/2"		3/4"		1"		1-1/4"		1-1/2"	
	N	P	N	P	N	P	N	P	N	P
185	-	15	30	65	95	250	400	-	-	-
265	-	10	20	40	60	140	250	560	-	-
335	-	-	15	25	35	85	150	380	360	-
405	-	-	-	15	25	60	100	260	250	-

PLUMBING FOR WATER CONNECTIONS LOCATION

The RP 2100 heater requires water flow and positive pressure to fire and operate properly. It must therefore be installed downstream of the discharge side of the filter pump. A typical installation is plumbed as follows:

1. The inlet side of the filter is plumbed directly to the discharge side of the filter pump;
2. The outlet side of the filter is then plumbed to the inlet of the heater; and
3. The outlet of the heater is plumbed to the return line to the pool or spa. The pump, filter and heater are thus plumbed in series.

Plumbing from the heater back to the pool must not have any valves or restriction that could prevent flow when the pump is operating.

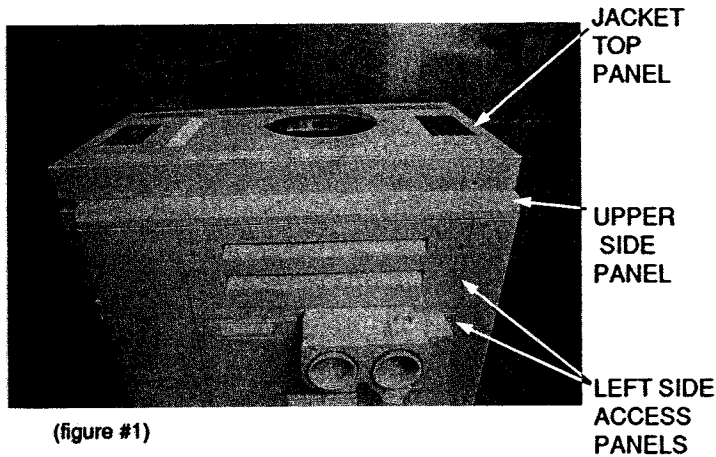

LEFT SIDE WATER CONNECTION CONVERSION

Dis-assembly:

1. Remove the jacket top, upper side panels, right and left side access panel (see figure #1).
2. Remove rain shield front and side panel assembly as follows: (see figure #2).
 - a) Remove front screws attaching rain shield to the vertical surface behind the control compartment.
 - b) Remove four (4) screws attaching the rain shield to the rear vertical support panel.
 - c) Remove front and side rain shield panels, leaving the back shield in place.
3. Remove the flue collector housing (see figure #3).
4. Disconnect wires to high limit and AGS (Automatic Gas Shut-off) limit switches in return and inlet/outlet header castings (see figure #4).
5. Remove pressure switch as follows: (see figure #4).
 - a) Disconnect wires to pressure switch.
 - b) Disconnect tube fitting from header casting.
 - c) Remove pressure switch with tubing through the front of the heater.
6. Remove thermostat temperature sensor (see figure #4).

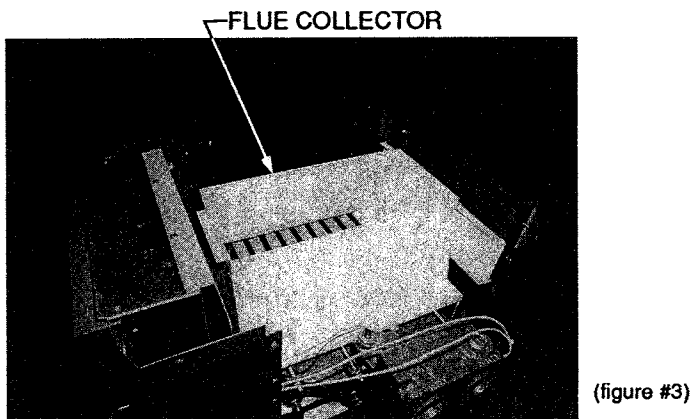
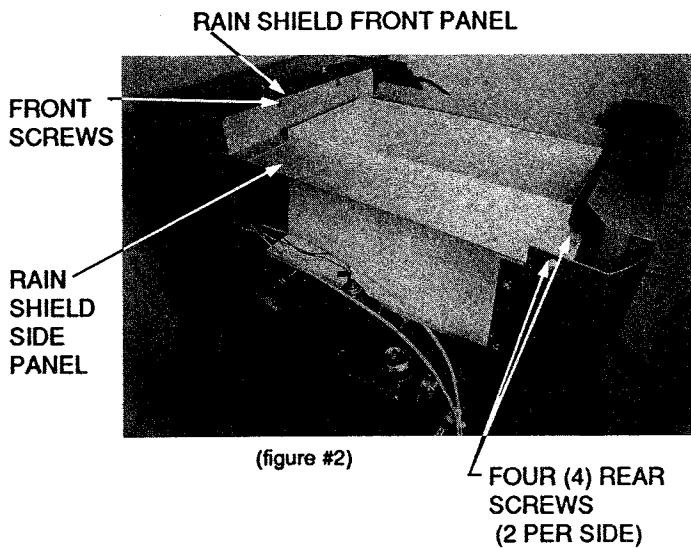

Electronic Ignition Models Only

- a) Disconnect the three (3) pin sensor plug from the poolstat circuit board (see figure #5).
- b) Push the connector plug and wires down through the control box holes (see figure #5) and then through the inner jacket panel hole into the heat exchange area (see figure #4).

Millivolt Ignition Models Only

Remove and re-route the temperature sensor bulb as follows: (see figure #4).

- a) Remove temperature sensor bulb from header casting.
- b) Pull the capillary tube and bulb through the hole on the right side of the inner cabinet panel.
- c) Re-route the capillary tube and bulb through the hole on the left side of the inner cabinet panel into the heat exchanger area.

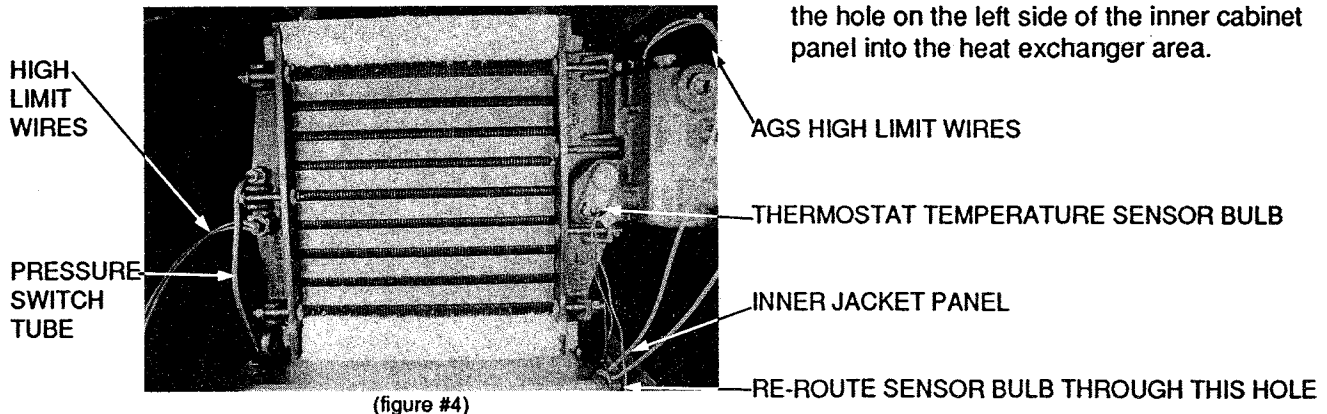

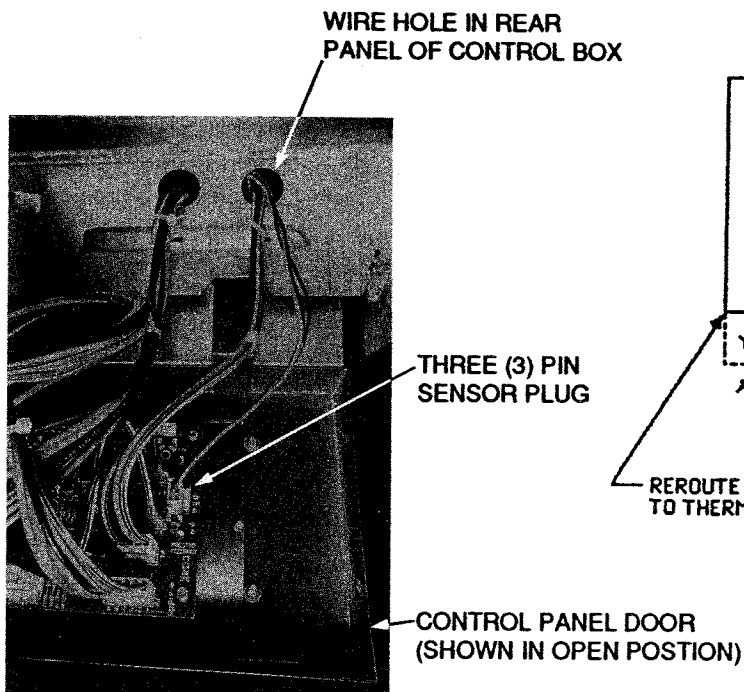

(figure #5)

Reverse Heat Exchanger:

7. Lift the complete heat exchanger straight up and out of the unit. Use care not to damage the combustion chamber blocks.
8. Re-route the pressure switch tube back through the right side of the inner cabinet panel.
9. Rotate the heat exchanger (inlet/outlet casting will be on the left) and lower it back into place above the combustion chamber. Again, be careful not to damage the combustion chamber blocks.

Assembly:

10. *Electronic Ignition Models Only.* Re-route the three (3) pin plug and sensor wires from the heat exchange area through the hole in on the right side of the inner cabinet panel then up into the control box. Plug the three (3) pin connector back into the poolstat circuit board (see figure #6).
11. *Millivolt Models Only.* Reinstall the sensor bulb (previously re-routed to the left side) into the sensor well of the inlet/outlet header.
12. Connect the pressure switch tube to the same hole it was removed from in the return header.
13. Re-route the pressure switch wires to the right side and connect them to the pressure switch.
14. *Electronic Ignition Models Only.* **OPTIONAL**, re-route the AGS wires to the left side and high limit wires to the right side. Connect the wires to the sensors in the header castings.

NOTE: If wires are not reversed the AGS and high limit diagnostic lights on the poolstat circuit board will be reversed.

Millivolt Ignition Models only: Reinstall wiring to the pressure switch as follows: (see wiring diagram)

- a) Connect the orange wire that was connected to the pressure switch to the thermal fuse.
- b) Remove the red wire from the TH/PP terminal on the gas valve and connect it to the pressure switch.
- c) Run the short red wire from the pressure switch to the TH/PP terminal on the gas valve (this was between the pressure switch and the thermal fuse).

15. Replace the flue collector. Use caution not to damage any wiring and make sure no wiring comes in direct contact with the flue collector.
16. Replace the rain shield and screws (see figure #2).
17. Reverse and replace right and left access panels
18. Replace top side panels and jacket top panel.

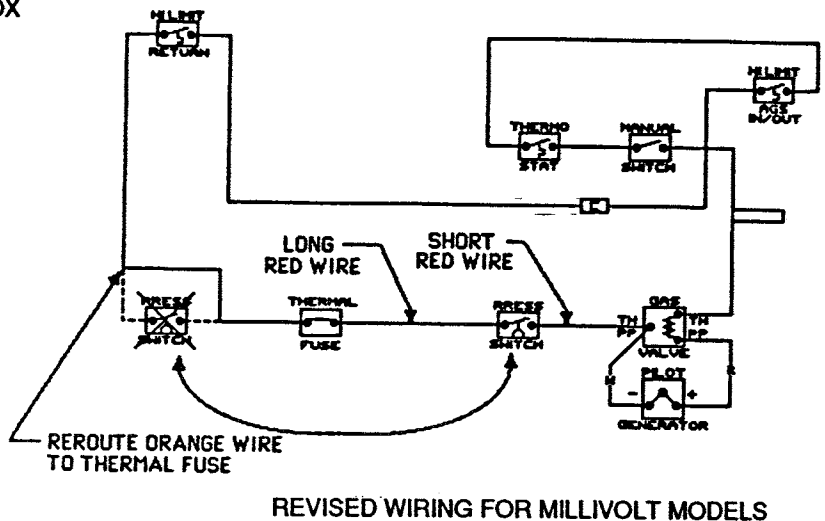

REVISED WIRING FOR MILLIVOLT MODELS

(figure #6)

Heater must be located so that any water leaks will not damage the structure of adjacent area. High temperature 2" plastic pipe (CPVC) may be threaded directly into the header flanges. This is not the same as the Schedule 80 PVC pipe which is also colored gray. PVC may be used immediately after the CPVC adapters.

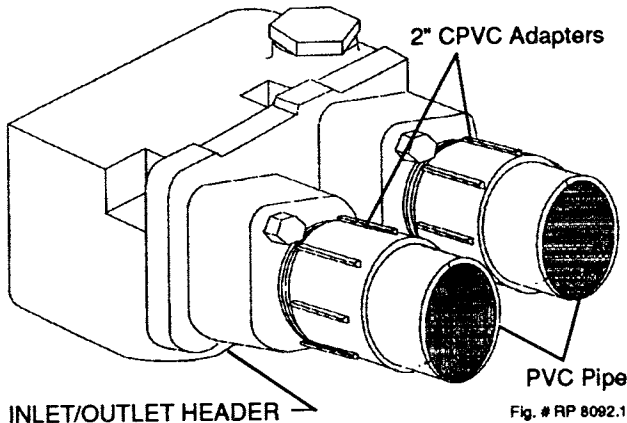

INLET/OUTLET HEADER

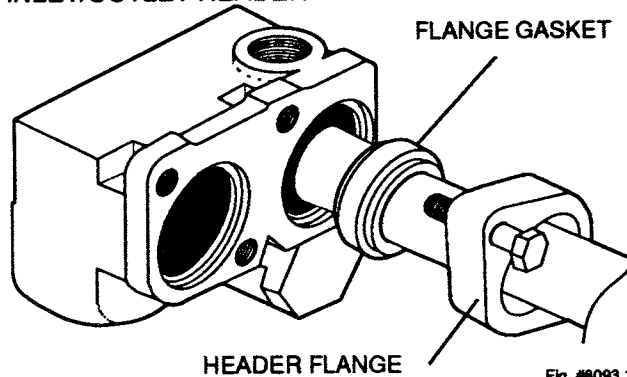

UNITHERM GOVERNOR OPERATION

The patented Unitherm Governor is a thermostatic mixing valve specifically designed to maintain constant heater internal temperature between 105° to 115°F despite continually changing flow rates from the filter and changing pool temperatures. This narrow range is needed to prevent damaging condensation on the burners which will occur if the heater runs for any length of time below 100°F. It is also needed to inhibit scale formation in the tubes by maintaining temperatures well below accelerated scaling temperatures.

INTERNAL AUTOMATIC BY-PASS VALVE

In addition to the Unitherm Governor, a built-in automatic by-pass valve is provided in the in/out header. While the Unitherm Governor responds to the changes in water temperature in the heater, the internal by-pass valve automatically responds to changes in water pressure in the piping system. Proper amount of water flow is maintained through the heater under varying pressures dictated by the conditions of the pump and filter.

CAUTION: NEVER install PVC directly into header flanges. use the 2" CPVC adapter supplied loose with the heater

FLOW RATES

MODEL	PIPE SIZE	MIN.GPM	*MAX.GPM
185	1-1/4"-1-1/2" - 2	20	125
265	1-1/4"-1-1/2" - 2	25	125
335	1-1/4"-1-1/2" - 2	35	125
405	1-1/4"-1-1/2" - 2	40	125

*When flow rates exceed maximum GPM an external auxiliary bypass valve is required. See external bypass valve section for details.

COMPANION FLANGE CONNECTIONS

DO NOT use petroleum base assembly fluids (such as Petroleum Jelly or lubricating oil). If assembly lube is required, use a silicone base such as Amoral etc.

There are two sets of flange gaskets supplied with your heater. Use the appropriate gaskets for all your heater connections. Discard unused set.

GASKET DESIGN #1: Accepts 1-1/2" copper tube or 1-1/4" galvanized pipe as a slip connection.

GASKET DESIGN #2: Accepts 2" copper tube as a slip connection. The flange is threaded for 2" screw in pipe connections. Also used with the 2" CPVC adapters.

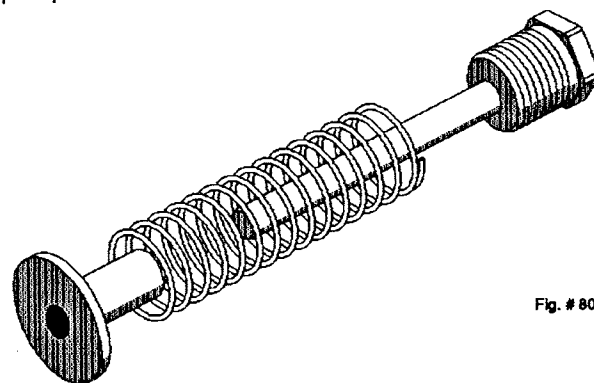
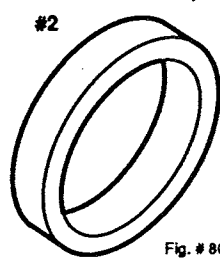
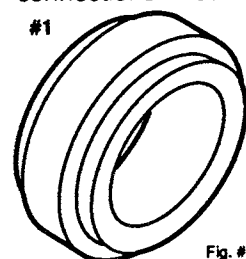

EXTERNAL AUXILIARY BYPASS VALVE (Where Required)

An auxiliary bypass valve should be used when flow rates exceed 125 GPM (usually a high performance pump size larger than two HP will exceed this flow rate). This valve is required to complement the function of the automatic bypass valve, particularly when starting the heater in winter or early spring when the spa or pool temperature is down below 50°F. It also serves to eliminate needless pressure drop through the heater and accompanying reduction in the flow rate to the spa jets, etc.

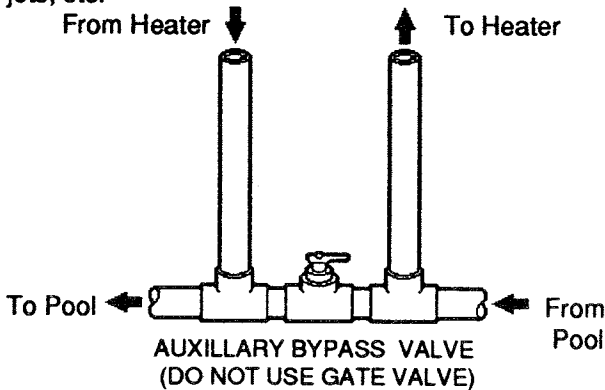

Fig. # 8150.0a

AUXILIARY BYPASS VALVE ADJUSTMENT

To set bypass: With clean filter, adjustment is made by feeling the inlet and outlet pipes at the heater. Outlet pipes should be slightly warmer than inlet and comfortable to the touch. If pipe is hot, close bypass; if cold, open bypass.

PRESSURE RELIEF VALVE INSTALLATION

To conform to local building codes, it may be necessary to install a pressure relief valve. A 3/4" pressure relief valve having a capacity equal to BTU/HR output of the model to be installed is recommended for this appliance.

A 3/4" NPT connection is provided in the inlet/outlet header for installation of a pressure relief valve. The valve shall be installed in a vertical position.

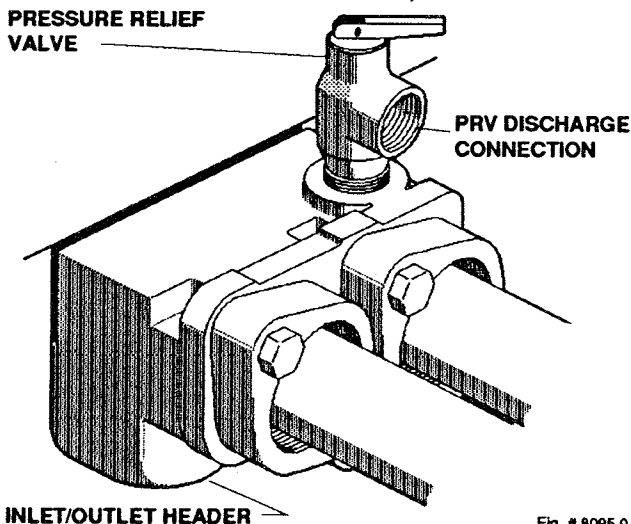

Fig. # 8095.0

NOTE: To avoid water damage or scalding due to valve operation, drain pipe must be connected to valve outlet and run to a safe place of discharge. Drain pipe must be the same size as the valve discharge connection throughout its entire length and must pitch downward from the valve. No shutoff valve shall be installed between the relief valve and the drain line. Valve lever should be tripped at least once a year to ensure that waterways are clear.

ELECTRICAL WIRING

NOTE: If it is necessary to replace any of the original wiring, it must be replaced with 105° C wire or its equivalent, and /or 150° C wire or its equivalent.

MILLIVOLT SYSTEM

The Millivolt System residential heater is equipped with a self-generating electrical system in which the electric current is provided by means of a pilot generator. No external electrical connections are required.

ELECTRONIC INTERMITTENT IGNITION DEVICE SYSTEM (IID)

NOTE: Heaters are factory wired for 240V power supply.

The standard field wiring connection is on the right side of the heater.

To wire the heater from the left side, follow the steps below:

1. Remove the two (2) screws that hold down the junction box to the sway brace. Untie excess yellow wires located behind the junction box.
2. Move the junction box to the left side of unit and attach the box to the sway brace.
3. Secure 24V yellow wires to sway brace panel with existing wire retainers.
4. Connect the wires inside the junction box, either 120V or 240V depending on the field wiring.

NOTE: 7/8" Dia. holes not utilized on jacket and control box can be used for fireman switch or auxiliary control interface wiring.

NOTE: Heater must be electrically grounded and bonded. Bonding lug is provided loose with the unit. Install bonding lug on lower right or left side of jacket as necessary for bonding the unit. Mounting hole is provided on the jacket.

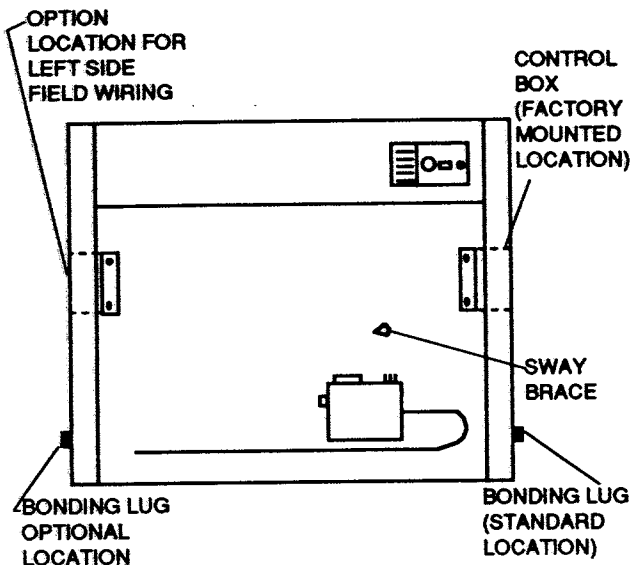

Fig. # RP 9030.1

The *Electronic Intermittent Ignition Device* automatically lights the pilot and main burners upon a call for the heat. The heater is supplied with a dual voltage transformer for 120V or 240V input power hookup.

NOTE: IID Propane Units Only
 Heater is equipped with an electronic ignition device with a 100% safety lockout feature. If the heater fails to start or lockout, reset the ignition device by interrupting the power to the heater for 60 seconds.

Caution: If service replacement of the electronic ignition device is required, replace only with a 100% safety lockout device with 90 second trial for pilot ignition.

**HONEYWELL
 IGNITION
 CONTROL**

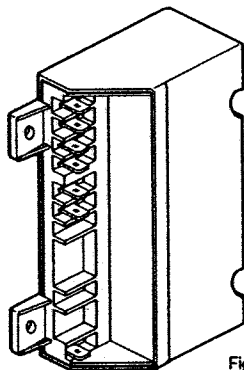

Fig. # 8929.1

For 120V input power to the unit, connect the red wire with the red/white wire, and connect the black wire with the black/white wire. Connect power supply to the black wire with the black/white wire leads, and to the red wire with the red/white wire leads of the transformer, as shown below.

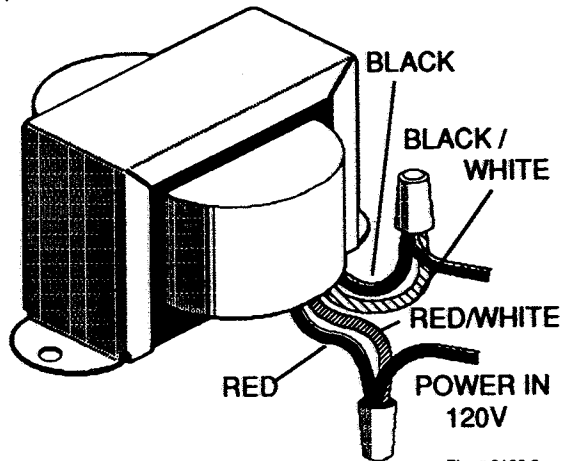

Fig. # 8100.0e

For 240 input power to the unit, connect the red/white with the black/white wire. Connect power supply to the black and red leads of the transformer as shown below.

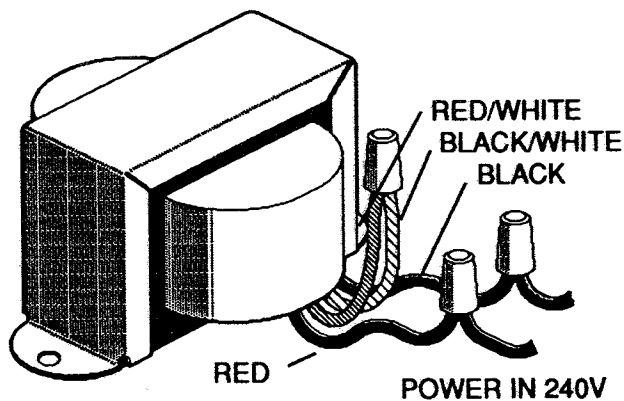
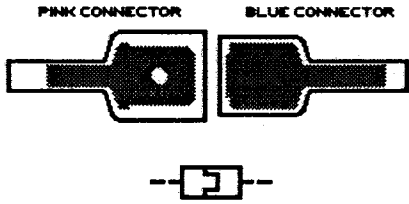

Fig. # 8099.0

Heater must be electrically grounded and bonded in accordance with local codes, or, in the absence of local codes, with the National Electrical code, ANSI/NFPA 70-1984.

NOTE: Input power to the heater (120/240V) should be supplied from the load (Pump) side of time clock or switch. Connecting heater to continuous power source will allow "Fail" indications (service and pressure switch) when pump is not operating.

WIRING DIAGRAM KEY



KEY	
	120V
	24V 105°C
	24V 150°C
	TERMINAL
	SINGLE POINT GROUND
	GROUND
R/Bk	RED/BLACK
G/Bk	GREEN/BLACK
O/Bk	ORANGE/BLACK
V/Bk	VIOLET/BLACK
W/Bk	WHITE/BLACK
Y/Bk	YELLOW/BLACK
Bk	BLACK
Y	YELLOW
BL	BLUE
R	RED
O	ORANGE
W	WHITE
W/R	WHITE/RED
	WIRE NUT

Fig. # RP8096

WIRING DIAGRAM MILLIVOLT UNITS WITH MECHANICAL THERMOSTAT

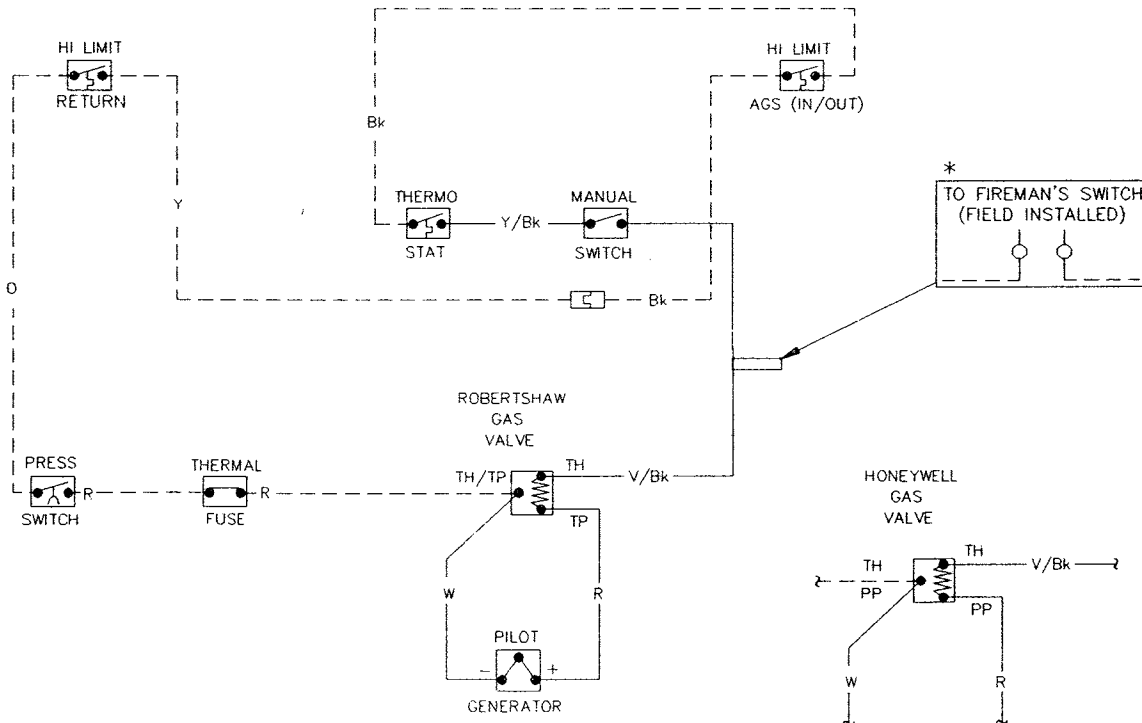

*If required by Local Code, install at this location.

Fig. # RP 1948e

WIRING DIAGRAM IID UNITS IGNITION DEVICE - HONEYWELL

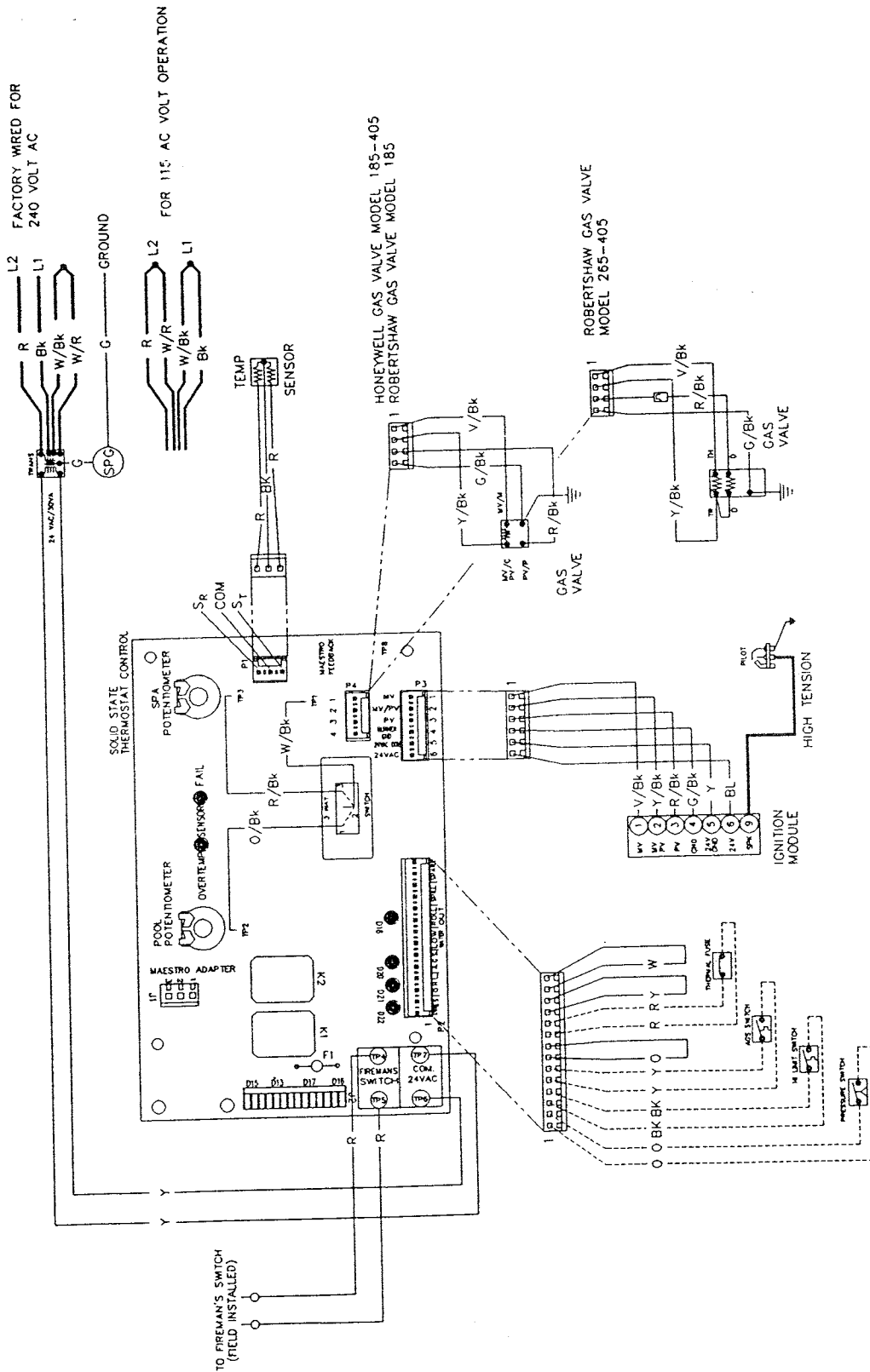

SECTION 4 / SERVICING INSTRUCTIONS

GENERAL LOCATION OF CONTROLS

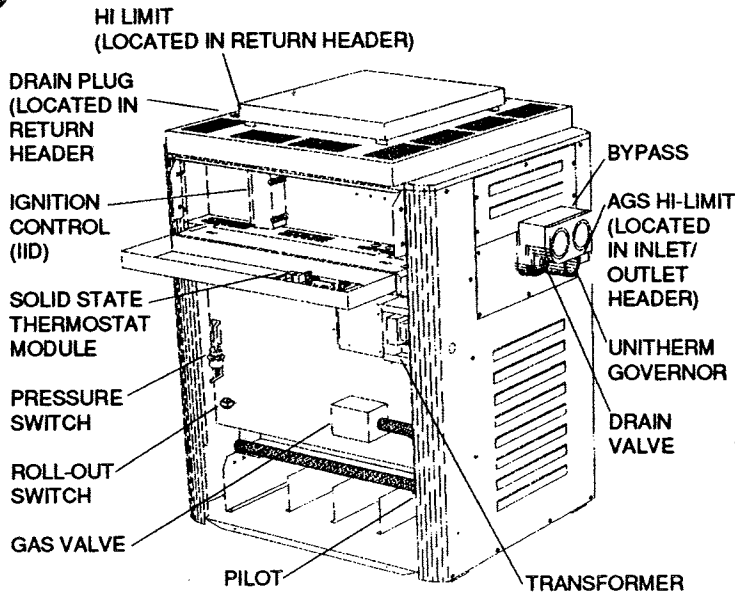

Fig. #RP 8070.1

CONTROL PANEL REMOVAL

1. Remove (4) screws from sides of control panel.
2. Rotate control panel down until panel stops. Do not force.

NOTE: Caution must be taken not to damage controls or wiring.

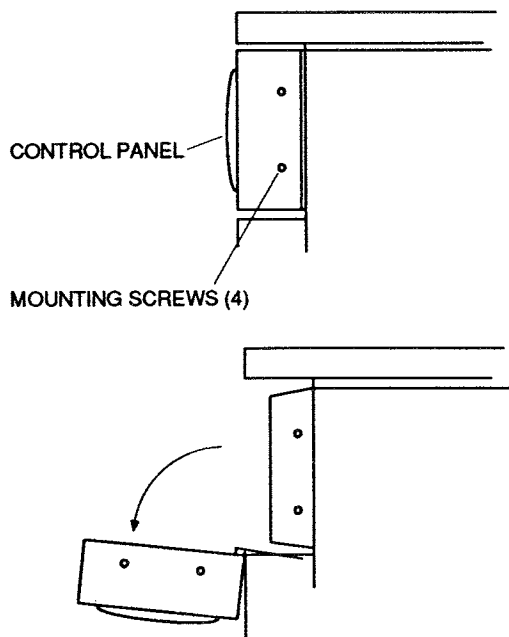

Fig. #RP 8267

CONTROLS/ADJUSTMENTS/REPLACEMENTS

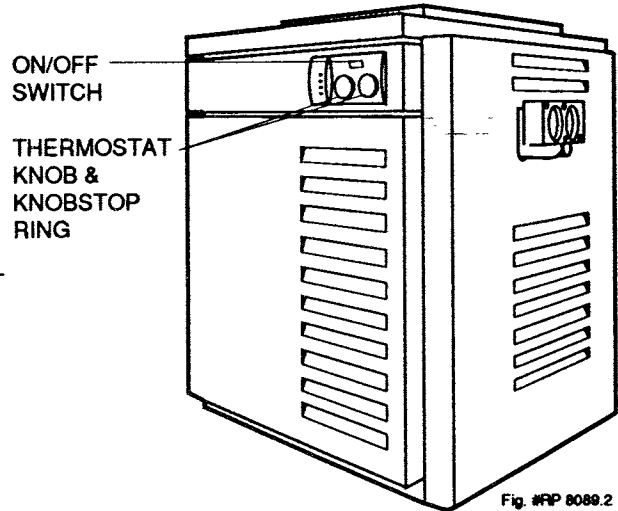

Fig. #RP 8089.2

TEMPERATURE CONTROLS

The pool or spa water temperature is controlled by the pool heater thermostat on the upper front panel of the heater. The control center contains an On/Off switch and one or two thermostats. Heaters fitted with two thermostats may be set up for one temperature setting when heating a spa and a second temperature setting for heating a swimming pool. The switch functions as a means for turning the heater on or off, and for switching between thermostats when fitted with two thermostats.

Thermostats are fitted with a means of limiting the upper temperature limit below the maximum level. The knob stop adjustment ring illustrated below is adjustable by loosening the set screw, rotating the knobstop ring to the desired location and retightening the set screw.

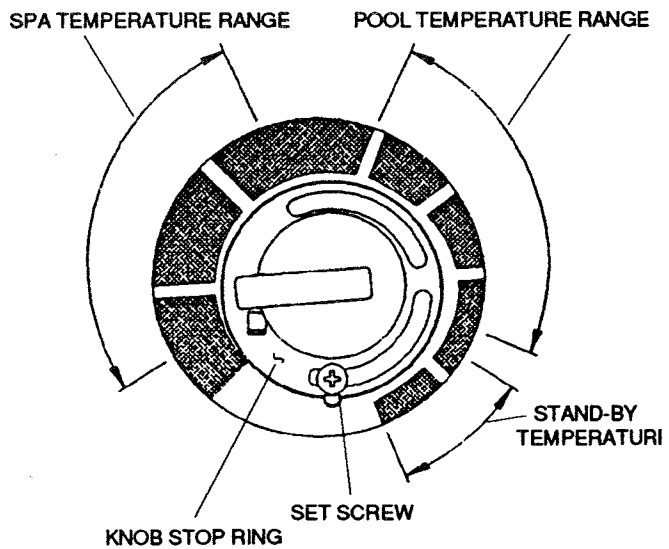

Fig. #8103.2

KNOB STOP SHOWN ABOVE IS IN THE SPA TEMPERATURE RANGE

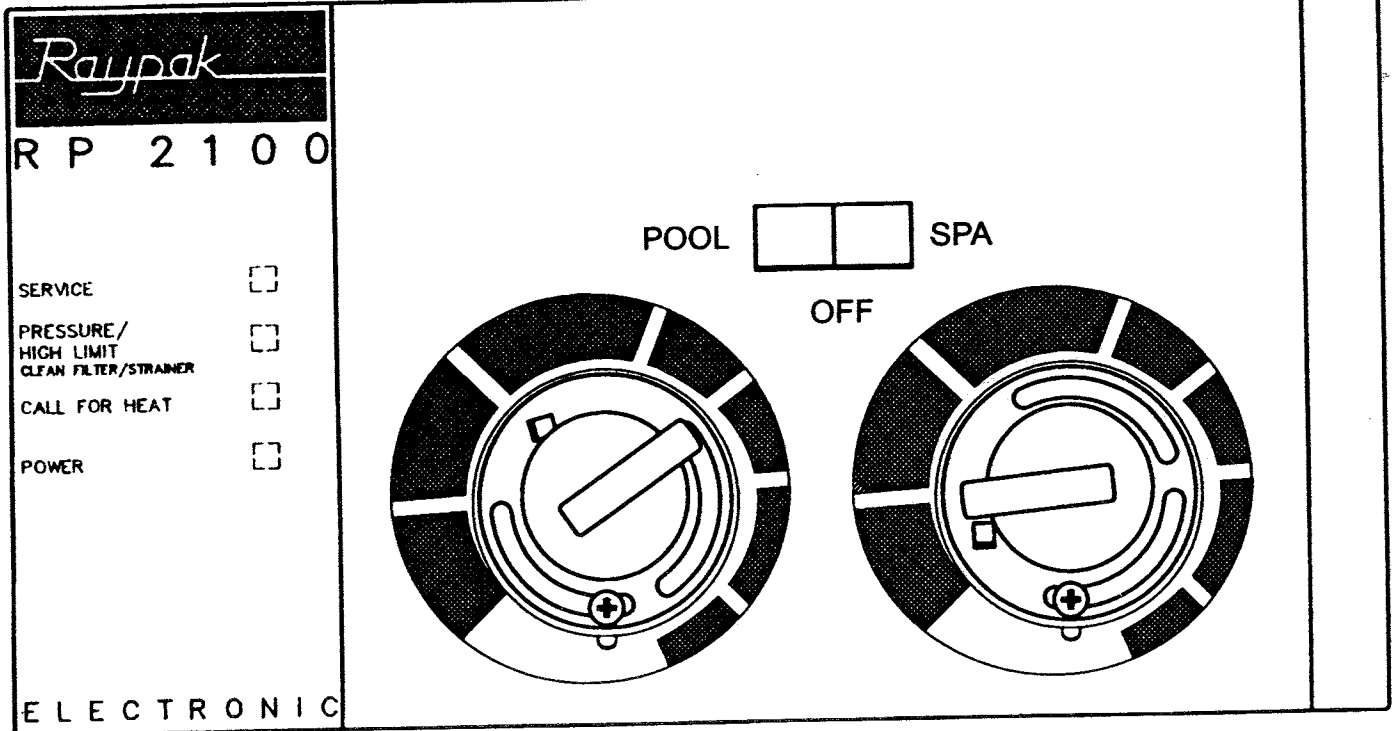

Fig. #RP 9004.1

There are four operational indicator lamps located on the RP 2100 Spa/Pool control panel. They are as follows:

1. The "Power" (green) lamp is on when power is applied to the RP 2100 Spa/Pool heater.

Green	ON	-	Power to Heater	Normal
-------	----	---	-----------------	--------
2. The "Call For Heat" (green) is on when thermostat is functionally calling for heat.

Green	ON	-	Call for Heater	Normal
-------	----	---	-----------------	--------
3. The "Pressure/High Limit" (red) indicates "safety" failure.

Red	ON	-	Pressure/High Limit Failure	Service Required
-----	----	---	-----------------------------	------------------
4. The "Service" (red) indicates failure of control/limit circuit.

Red	ON	-	Service Required	Service Required
-----	----	---	------------------	------------------

NOTE : If both the "Service" and "Pressure/High Limit" indicators are On, check first and make sure that the Filter/Strainer are clean before calling for service.

PRESSURE SWITCH

The pressure switch, or heater actuator, insures that the heater operates only when the filter pump is in operation. It is factory set at 1.75 PSI for deck level installations. When the heater is located below the level of the spa or pool, it may be necessary to reset the pressure switch to compensate for the no-flow static head. If it is necessary to reset the pressure switch, we recommend the following procedure:

PRESSURE SWITCH ADJUSTMENT:

1. With pump and heater on, turn adjustment knob (clockwise) until a click is heard from the gas valve.
2. Turn adjustment knob (counter clockwise) 1/4 turn.
3. Turn pump off and on several times. Heater should shut off immediately. If it does not, repeat steps above until proper adjustments made.

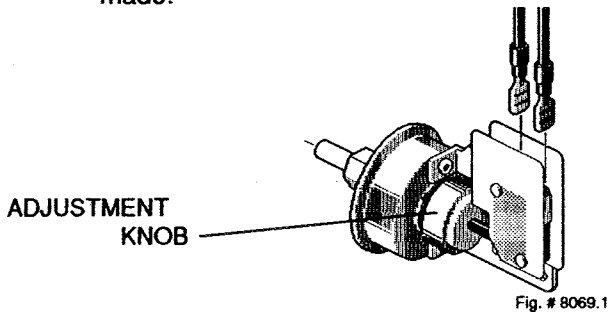

PRESSURE SWITCH ADJUSTMENT RANGE

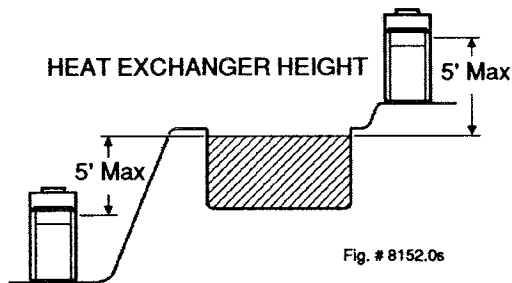

NOTE: If heater is installed outside of the limits shown, a flow switch must be used in place of the pressure switch when mounted and wired adjacent to the heater.

TWO SPEED PUMPS

In some cases, the flow on the low speed is insufficient to operate the heater. This is apparent when the pressure switch cannot be further adjusted or if the heater makes banging noises. In these cases, the pump must be run at high speed when heating the water.

CAUTION: Do not operate the heater without the function of a properly adjusted pressure switch or flow switch.

FLAME ROLL-OUT SAFETY SWITCH

The heater is equipped with a thermal cutoff device to prevent flame roll-out in the event the heat exchanger becomes blocked. This is a "Single-use" type fusible link or thermal fuse, that must be replaced when disabled by an over temperature condition, caused by excessive restriction in the heat exchanger flue passage.

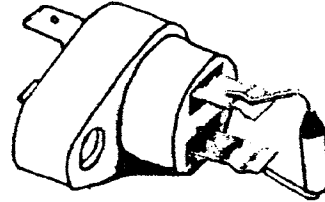

Fig. #9177

HIGH LIMITS

The heater is equipped with two automatic high limits. One is located in the return header, set to open at 140°F. The other is the Automatic Gas Shut off limit, set to open at 135°F and located in the Inlet/Outlet header.

NOTE: An erratic high limit is often characteristic of internal heat exchanger problem, i.e. scale buildup, defective bypass. Refer to troubleshooting sections.

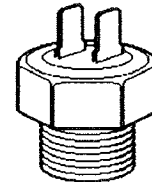

Fig. # 8153.06

HIGH LIMIT REMOVAL

1. Shut off main electrical power switch to heater.
2. Remove inspection panels.
3. Drain heater.
4. Remove defective high limit and replace with a new high limit.
5. Reverse above procedure to reinstall.

PILOT SAFETY (Millivolt System)

The heaters equipped with the standing pilot (millivolt system), have pilot generators which act as a safety device to shut off the flow of gas to the main burners and the pilot burner in case the pilot flame is extinguished. The pilot burner must be manually relighted to place the heater in operation again. Refer to the lighting instructions provided on the heater label.

PILOT SAFETY (IID Units) ELECTRIC IGNITION

The heater employs a pilot safety which closes the main gas valve within 8/10ths of a second whenever the pilot flame is interrupted. Pilot flame is automatically lit when the device is powered. Unit performs its own safety check and opens the main valve only after the pilot is proven to be lit.

BURNER DRAWER REMOVAL

1. Shut off main electrical power switch to heater.
2. Shut off gas upstream of heater.
3. Remove front door.
4. Disconnect gas line from gas valve.
5. Remove (2) screws that mount burner tray to unit, and (2) screws that secure gas valve to jacket.
6. Disconnect wires that terminate at gas valve.
7. Slide out burner tray.
8. Reverse above procedure to reinstall.

GAS VALVE REMOVAL

1. Shut off gas supply to the heater. Remove gas piping to gas valve inlet.
2. Disconnect wires, pilot tubing and bleed line, if required.
3. Turn vertical gas pipe from manifold slightly and unscrew gas valve.
4. Reverse above procedure to re-install.

MAIN BURNER AND ORIFICE REMOVAL

1. Remove burner drawer. See burner drawer removal procedure.
2. Remove screws and burner hold down bracket.

NOTE: If the heat exchanger is sooted badly, the burner hold down bracket and spacer can become distorted from direct flame impingement and this usually necessitates replacement of these parts.

3. Lift burners from slotted spacers and slide from orifices. Clean with a wire brush.
4. Orifices usually do not need to be replaced. To clean, run either copper wire or wood toothpick through orifice. Do not enlarge hole. To remove orifice, use a socket wrench and remove from manifold. **DO NOT** overtighten when reinstalling.

BURNER HOLD DOWN BRACKET

BURNER

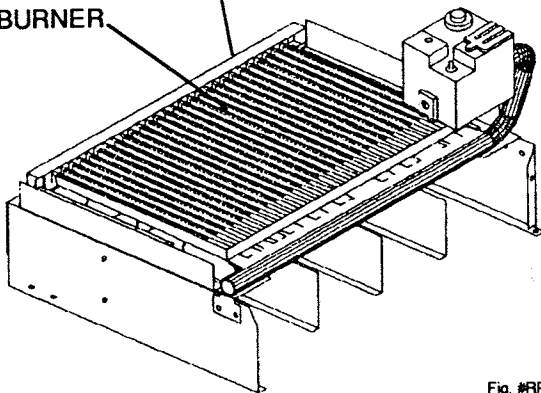
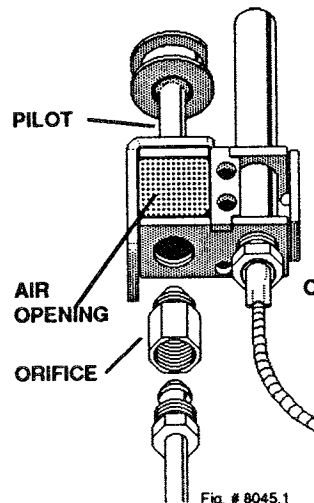

Fig. #RP 8057.0

PILOT REMOVAL AND CLEANING

1. Disconnect pilot tubing, and wires from gas valve.
2. Remove pilot assembly from burner tray.
3. Remove pilot from bracket.
4. Remove pilot orifice and air opening (Honeywell MV unit only), and clean with wire or small brush. **CAUTION!** Do not enlarge hole in pilot orifice.
5. Reverse above procedure to re-install.

HONEYWELL PILOT



ROBERTSHAW PILOT

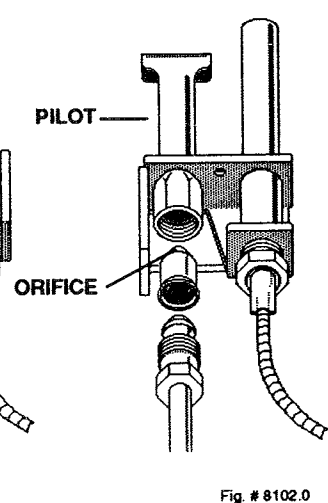

HEAT EXCHANGER REMOVAL

1. Shut water, gas and electricity off, close valves and relieve pressure, remove relief valve. Remove side inspection panels.
2. Remove top holding screws.
3. Remove draft diverter, lift and remove top and flue collector. Remove inspection panels.
4. Loosen bolts and disconnect flange nuts on inlet-outlet header, loosen union(s) at gas pipe and slide boiler away from piping until studs clear the header.
5. Lift heat exchanger straight up using caution not to damage refractory.
6. Reverse above procedure to reinstall.

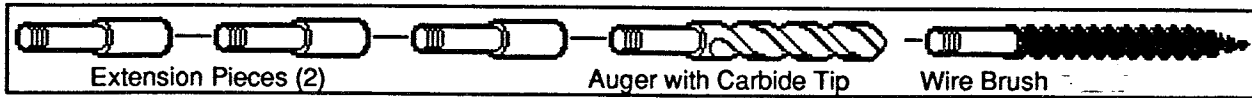

Fig. # 8154.0

TUBE CLEANING PROCEDURE

Establish a regular inspection schedule, frequency depending on local water condition and severity of service. Do not let the tubes clog up solidly. Clean out deposits over 1/16" in thickness.

The heater may be cleaned from the return header side, without breaking pipe connections. It is preferable, however, to remove both headers for better visibility through the tubes and to be sure the ground-up lime dust does not get into the system.

Note that you do not remove the top panel or the heater exchanger, generally.

After reaming, mount the wire brush in place of the auger and clean out debris remaining in the tubes.

Another method is to remove the heat exchanger, ream tubes and immerse heat exchanger in non-inhibited de-scale solvent for severe scale build-up.

TUBE REPLACEMENT PROCEDURE

On Raypak units, tube replacement may be effected without rolling, as a temporary means of repair, providing there are two or more tubes rolled in to act as stays on the left and right sides. The "O" rings should provide a seal up to 125 PSI working pressure. Use 3/8" heavy duty reversible drill motor or large to power the tube roller. If a reversible drill is not available, after rolling the tube in, remove the drill motor and wrench out the roller. A tube roller is available from the factory.

Shut gas and power off to the unit, close the system off and drain the heater. Remove the draft diverter. Remove the access panel and jacket top. Lift flue collector off. Remove "V" baffles over tube(s) to be replaced. If no pipe unions have been provided, use the header as a union, remove the flange nuts off the inlet-outlet header, break gas connection and slide heater away from piping to allow room to work. Pull wedge clips out of control wells and remove sensing bulbs. Remove flange nuts of the return header and remove header. Lift heat exchanger straight up and inspect "O" ring seals at this time. Unless severed, they are reusable. The tube may be cut out with a hacksaw or hammer and chisel adjacent to both tube sheets, leaving studs in the tube sheets. Then proceed to collapse studs in the tube sheets with a chisel or screwdriver. Use caution not to cut into the tube sheet. Replacement tubes will have the fins stripped off longer on one end. The long end is inserted into the opening of the tube sheet first; then the short end is fitted through the opposite tube sheet. If the tube ends become dented or bent, straighten at least (4) inches back from the tube and by means of a tapered punch.

Insert tube roller into tube opening up to stop

against tube, then push center rod in until roller is tight. Be careful to keep replacement tube squared up 1/8" outside each tube sheet. A loose tube will sometimes pull toward the roller. Attach drill motor to tube roller, holding it straight and level. Proceed to expand tube until the tool begins to grab. At this point, 1/2" to 1" should be exposed on the tool shank. Reverse drill motor or wrench out by hand. Care should be exercised to avoid applying excessive torque during rolling operation and to avoid thinning out any part of the tube wall excessively over .015". Use same procedure at the opposite end of the tube.

Apply line pressure test, and re-roll, if necessary, before re-assembly of the heater.

DESOOTING PROCEDURE

CAUTION: SOOT IS COMBUSTIBLE. EXERCISE EXTREME CARE:

Soot will clog areas between fins and cause eventual tube failure. Any sign of soot at the base of the burners or around the outer jacket indicates a need for cleaning.

1. Remove top and flue collector from cabinet.
2. Remove "V" baffles from heat exchanger.
3. Remove burner drawer. (See burner tray removal).
4. Remove heat exchanger from the heater and wash with a garden hose, making sure soot is removed from spaces between fins.
5. Reverse above procedure to re-install.

NOTE: In extreme cases it may be necessary to do steam cleaning at the local car wash. DO NOT WIREBRUSH.

COMBUSTION CHAMBER REMOVAL

To remove combustion chamber, you must first have removed the heat exchanger. Unbolt metal combustion chamber retainer from top and remove combustion chamber panels individually.

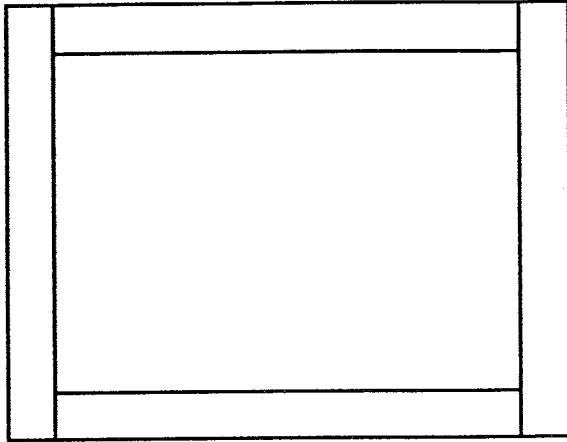

REFRACTORY PANELS TOP VIEW

Fig. # RP8155.06

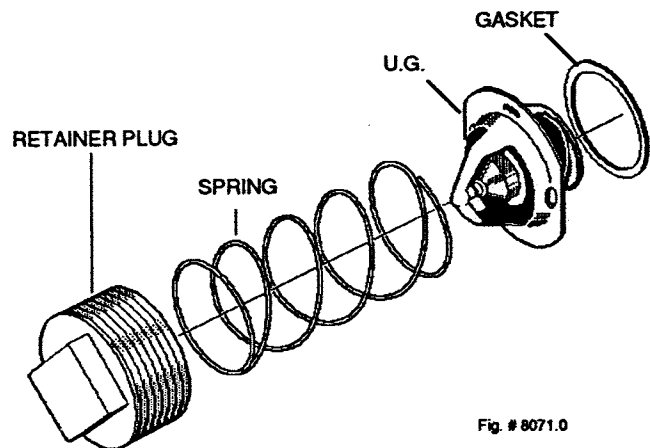

Fig. # 8071.0

To test the operation of the Unitherm Governor, place in hot water (over 100°F) and watch for movement against spring. If there is no movement, replace unit.

CONTROL IMMERSION WELL REPLACEMENT

1. Shut water off to heater and drain heat exchanger.
2. Remove access panel on water connection side of heater.
3. Remove old control well with bushing and sleeve, with 7/8" wrench or socket.
4. Slip "O" ring gasket over control well and install in header.

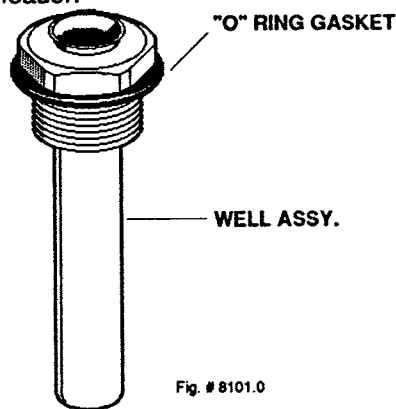

Fig. # 8101.0

UNITHERM GOVERNOR (U.G.) REPLACEMENT

1. Shut water, gas and electricity off, close valves and relieve pressure.
2. Drain heat exchanger.
3. Remove retainer plug located under outlet pipe connection.
4. Remove spring and replace old U.G. with a new U.G.
5. Reverse above procedure to re-install.

SECTION 5 / TROUBLE SHOOTING GUIDE

IMPORTANT NOTICE

These instructions are primarily intended for the use of qualified personnel specifically trained and experienced in the installation of this type of heating equipment and related system components. Installation and service personnel may be required by some states to be licensed. Persons not qualified shall not attempt to install this equipment nor attempt repairs according to these instructions.

MECHANICAL (FOR QUALIFIED SERVICE PERSONNEL ONLY)

<u>PROBLEM</u>	<u>CAUSE</u>	<u>SOLUTION</u>
Harmonics, or whining noise.	U.G. inoperative.....	Check movement by putting in hot water (110°F or higher). If no movement, replace.
	*Debris or restriction in system.....	Locate the restriction and remove. Flush system and clean.
	*Debris in gas line.....	Remove debris or blow out gas line.
	Low flow.....	Scale forming in heat exchanger - clean heat exchanger and check pool pH and total alkalinity.
Heater going on and off continuously.	Dirty filter.....	Backwash filter.
	Low water level in pool.....	Raise water level.
	External bypass setting out of adjustment.....	Adjust bypass
	*Pressure switch out of adjustment.....	Adjust pressure switch
Liming or scale forming on 7.8 heat exchanger.	Pool water.....	Recommended pH should be between 7.4 and 7.8 total alkalinity 100-150 PPM maximum. Hardness 150-400 PPM maximum.
Sooting	High flow rates.....	Reduce by adding manual bypass valve and adjust by putting thermometer in header (1/4" NPT) drain opening. Set bypass so thermometer reads between 105° and 110°F.
	U.G. Inoperative.....	Check movement by putting in hot water (110°F or higher). If no movement, replace.
	*Air starvation.....	Refer to installation instructions.
	*Improper venting.....	Follow recommended installation instructions.
	*Insects or debris clogging burner intake ports.....	Clean burners.
Pilot outage.	Low gas pressure.....	Adjust gas pressure.
	Restricted pilot.....	Clean pilot.
	Weak pilot generator.....	Replace pilot.
Yellow lazy flame	Low gas pressure.....	Adjust gas pressure.
	*Insects or debris clogging burner intake ports.....	Clean burners.
Outer jacket very hot (paint blistered)	*Broken refractory caused by shipping damage or improper combustion.....	Replace refractory panels.
Takes long time to heat pool or spa.	Excessive sooting of heat exchanger.....	Determine cause of sooting & correct.
	Calculate temperature in °/hr.....	Heat rise (°/hr.) = $\frac{\text{Htr. output}}{\text{Pool gallonage} \times 8.33}$ or refer to heater sizing chart. This does not take into account heat loss due to weather.
	Filter not running long enough.....	Reset time clock.
	Dirty filter.....	Clean filter.
	Gas line or meter undersized.....	Refer to installation instructions.
Liming	Bypassing too much water.....	Inspect bypass for movement, if no movement, replace.
	U.G. not functioning.....	Replace if no movement when heated.

(* Usually occurs on Initial start-up.)

Leaking at well.	Overacid.....	Replace well and maintain water chemistry properly.
Leaking at heat exchanger.	Overacid.....	Replace heat exchanger and maintain chemistry properly.
Gasket brittle and leaking - (overheated).	Heater running after pump shuts off.....	See pressure switch adjustment.
	Refractory damage.....	Replace refractory.
	Sooted heater.....	Determine cause of sooting and correct.

ELECTRICAL (STANDING PILOT MILLIVOLT)

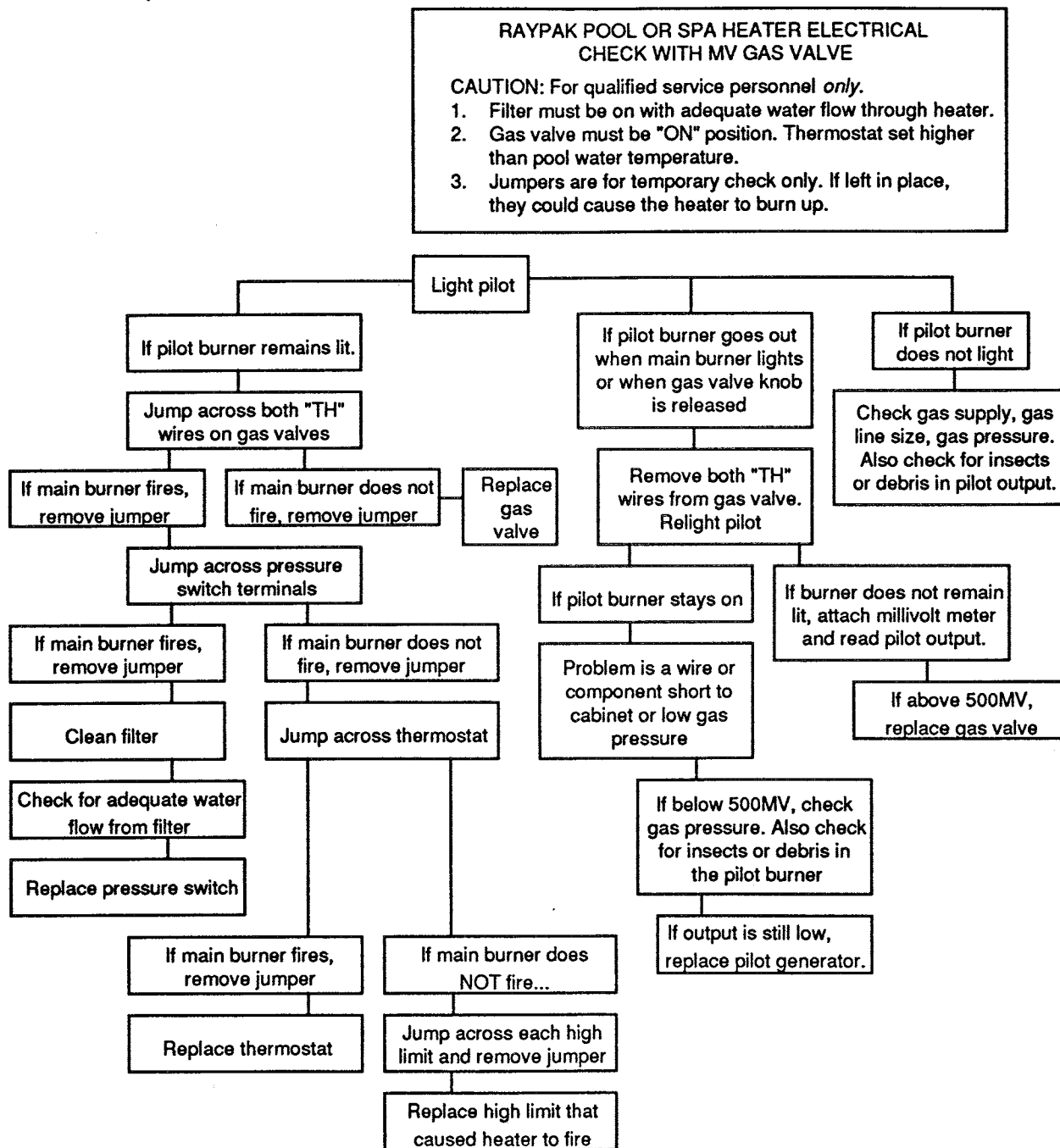

ELECTRICAL (ELECTRONIC IGNITION IID)

WARNING
HIGH VOLTAGE
 For qualified Technicians ONLY

NOTE: Some heaters may be equipped with an ignition module that shuts off pilot gas if pilot fails to light. To reset, interrupt power to heater.

Intermittent Pilot System TROUBLESHOOTING HONEYWELL S8600

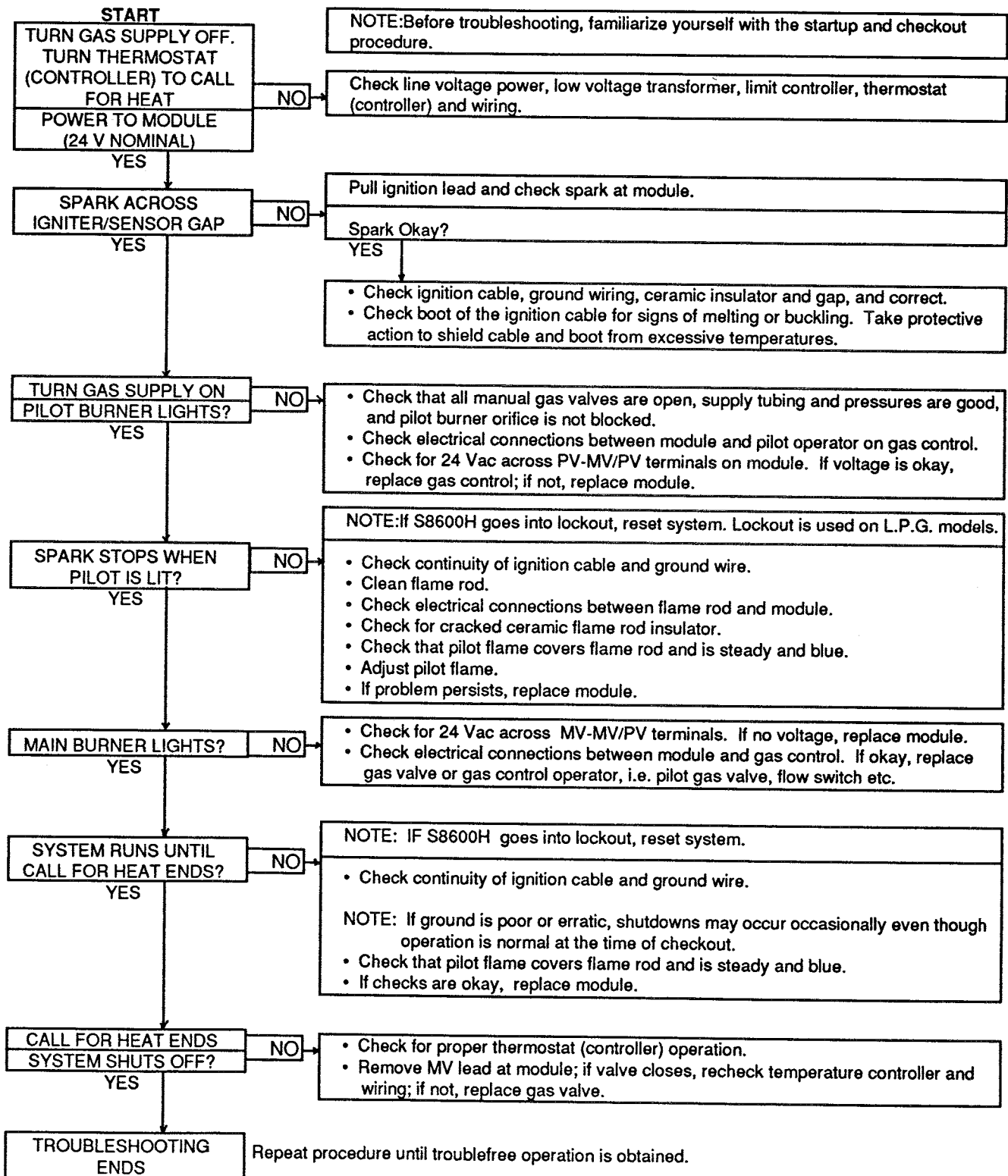

RP 2100 - IID DIAGNOSTIC FLOW CHART HEATER WILL NOT FIRE

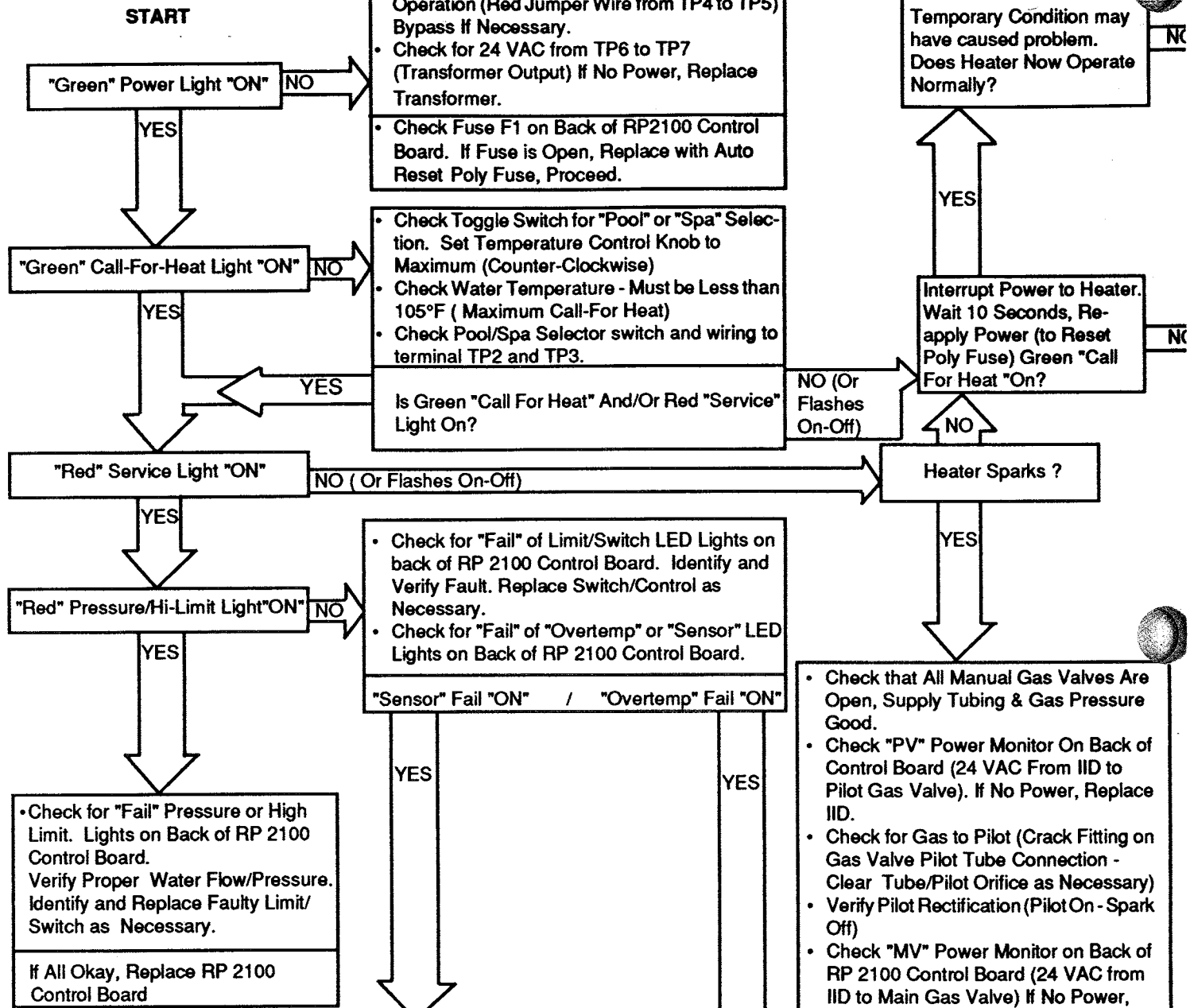

Sensor "Fail"

- Inspect Thermister, wires, and connector at Terminal P1.
- Using an Ohmmeter, measure resistance from Red (ST) to Back (Com) and Red (SR) to Black (Com), if not within 5% of each other replace Thermister.
- Check resistance value of Thermister. Reference to chart below. Replace Thermister in not within 10% of values shown.
- If all okay, replace RP 2100 Control Board.

SENSOR RESISTANCE AT VARIOUS TEMPERATURES

TEMP DEGREES F	40	50	60	70	80	90	100	106
Resistance (K)	26.11	19.90	15.31	11.88	9.30	7.33	5.83	5.10

If All Okay, Replace RP 2100 Control Board

OVERTEMP "FAIL"

Fail	May indicate temporary residual heat in heat exchanger. Will reset automatically as heater cools or if cooler water is introduced to heater.
- OR -	
Fail	May indicate failure of RP 2100 Control Board. If power to heater must be interrupted to reset, replace RP 2100 Control Board.

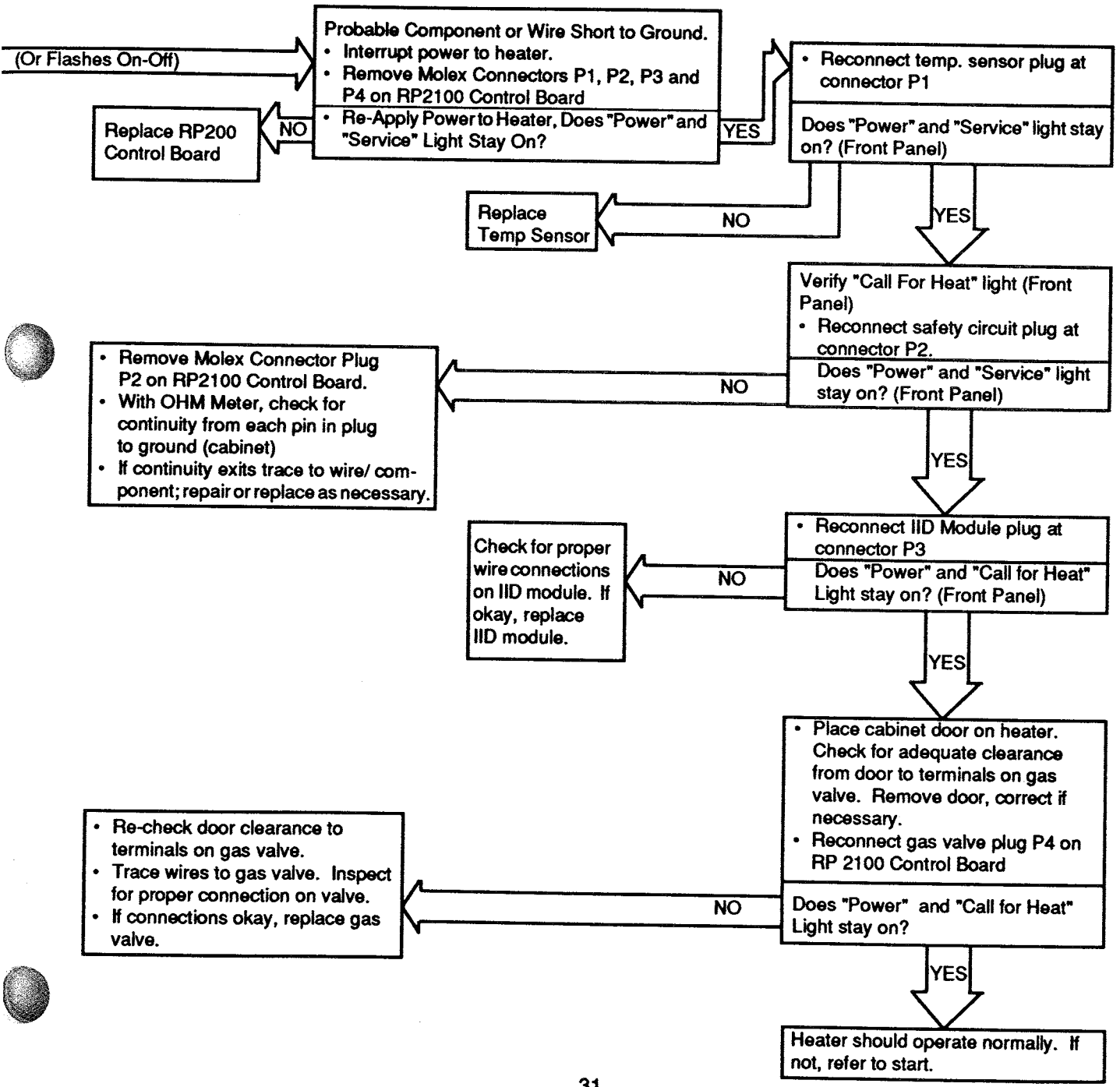
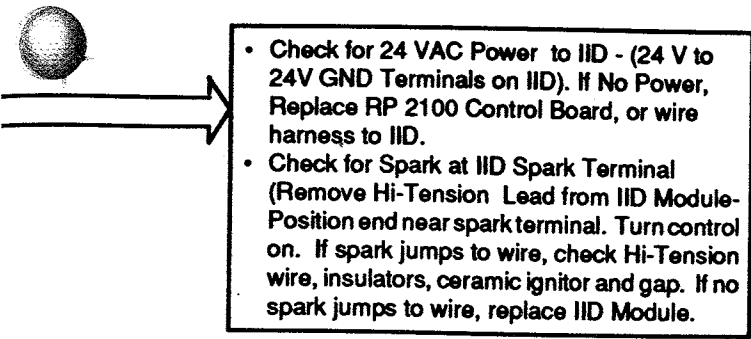

SECTION 6/REPLACEMENT PARTS LIST

NOTE: To supply the correct part it is important that you state the model number, serial number and type of gas when applicable.

Any part returned for replacement under standard company warranties must be properly tagged with RAYPAK return parts tag, completely filled in with the heater serial number, model number, etc., and shipped to the Company freight prepaid.

If determined defective by the Company and within warranty, the part will be returned in kind or equal substitution, freight collect. Credit will not be issued.

RAYPAK, INC
31111 AGOURA ROAD
WESTLAKE VILLAGE, CA 91361-4699

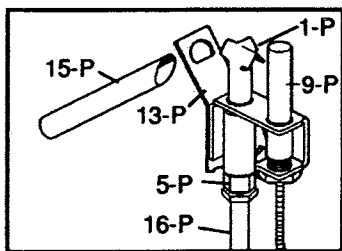
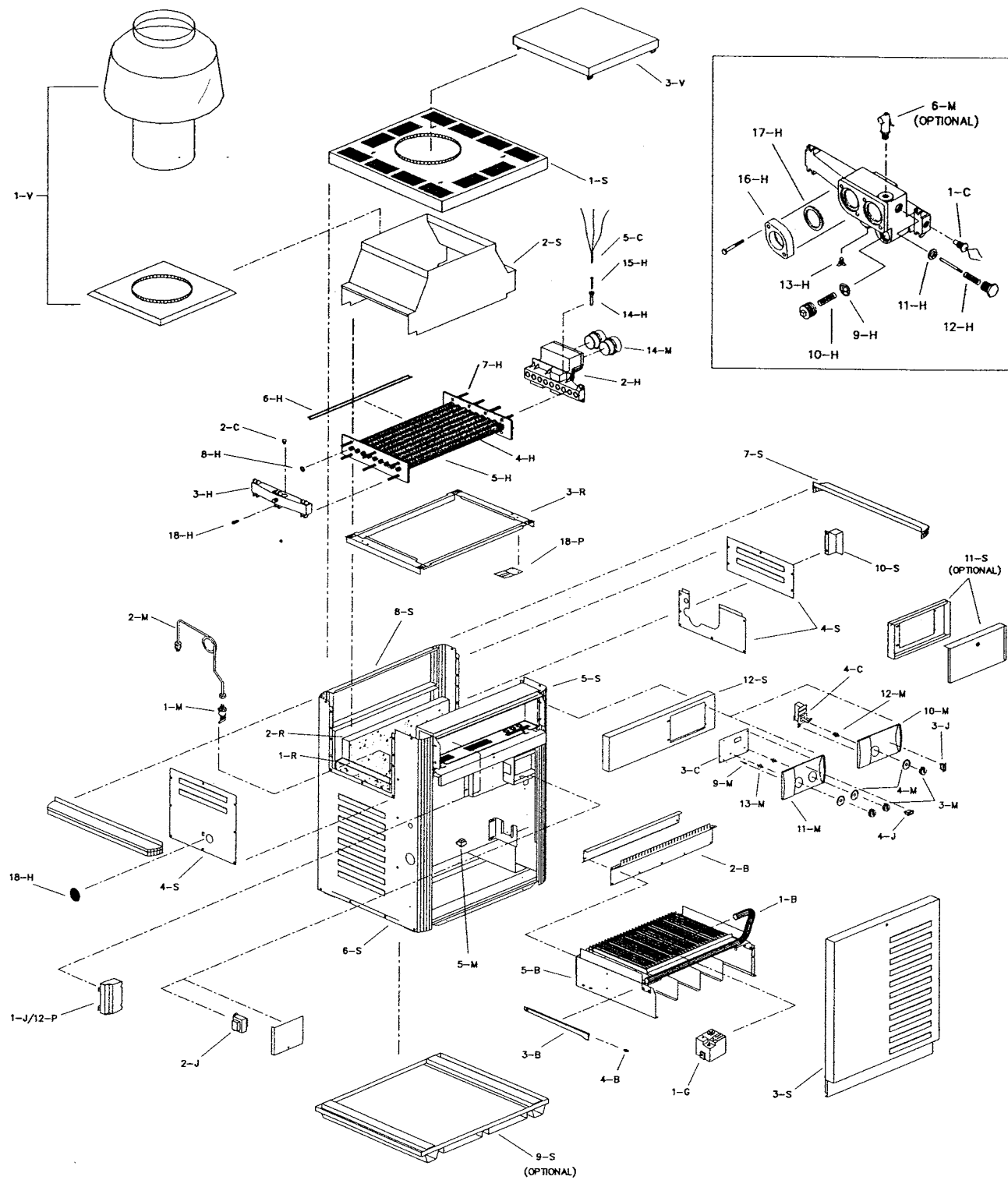

Robertshaw MV

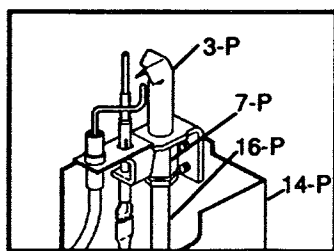

Robertshaw IID

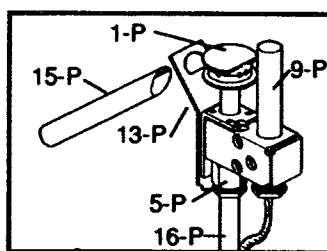

Honeywell MV

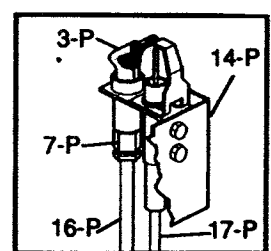

Honeywell IID

CALL OUT	DESCRIPTION	185	265	335	405
B	BURNER TRAY				
1-B	Burner Tray w/Burners (Sea Level)*	005213F	005214F	005215F	005216F
	Burner Tray w/o Burner (Sea Level)*	005217F	005218F	005219F	005220F
	Burner Tray w/Gas Valve Nat STG	005221F	005222F	005223F	005224F
	Burner Tray w/Gas Valve Pro STG	005225F	005226F	005227F	005228F
	Burner Tray w/Gas Valve Nat IID	005229F	005230F	005231F	005232F
	Burner Tray w/Gas Valve Pro IID	005233F	005234F	005235F	005236F
2-B	Burner Spacer/Hold Down Kit	005237F	005238F	005239F	005240F
3-B	Burner	301210/13	301210/19	301210/24	301210/29
4-B	Burner Orifice Nat. #51 (Sea Level)*	350080/13	350080/19	350080/24	350080/29
	Burner Orifice Pro. #57 (Sea Level)*	350083/13	350083/19	350083/24	350083/29
5-B	Burner Tray w/o Manifold w/o burners	005265F	005266F	005267F	005268F
C	CONTROLS				
1-C	AGS 135° (Auto Gas Shut-Off) - Red Epoxy	600892B	600892B	600892B	600892B
2-C	High Limit 140° - Black Epoxy	600893B	600893B	600893B	600893B
3-C	P. C. Board Control IID Units	005241F	005241F	005241F	005241F
6-C	Fuse PC Board IID Units	005384F	005384F	005384F	005384F
4-C	Thermostat Control MV Units Mechanical	600827B	600827B	600827B	600827B
5-C	Temperature Sensor IID Units	005299B	005299B	005299B	005299B
G	GAS VALVE				
1-G	Combination Valve - Nat. MV	003898F	003898F	003898F	003898F
	Combination Valve - Pro. MV	003899F	003899F	003899F	003899F
	Combination Valve - Nat. IID	003900F	003900F	003900F	003900F
	Combination Valve - Pro. IID	004306F	004306F	004306F	004306F
H	HEAT EXCHANGER				
1-H	Heat Exchange Assy. CI (Complete)	005244F	005245F	005246F	005247F
	Heat Exchange Assy. BR (Complete)	005248F	005249F	005250F	005251F
2-H	Inlet/Outlet Header CI	003759F	003759F	003759F	003759F
	Inlet/Outlet Header BR	003760F	003760F	003760F	003760F
3-H	Return Header CI	002450F	002450F	002450F	002450F
	Return Header BR	002451F	002451F	002451F	002451F
4-H	Tube Bundle	005252F	005253F	005254F	005255F
5-H	Heat Exchange Tube (1)	005256F	005257F	005258F	005259F
6-H	Baffle Kit (8)	005260F	005261F	005262F	005263F
7-H	Bolt Kit	001303F	001303F	001303F	001303F
8-H	Header Gasket	800014B	800014B	800014B	800014B
9-H	Unitherm Governor	062234B	062234B	062234B	062234B
10-H	U.G. Retainer Spring	850254	850254	850254	850254
11-H	Bypass Valve	062235B	062235B	062235B	062235B
12-H	Bypass Spring	850252	850253	850253	850253
13-H	Drain Valve	500719	500719	500719	500719
14-H	Sensor Well	003765F	003765F	003765F	003765F
15-H	Well Retaining Clip	300203	300203	300203	300203
16-H	Inlet & Outlet Flange	003766F	003766F	003766F	003766F
17-H	Flange Gasket 1 1/2" Connections	062236B	062236B	062236B	062236B
	Flange Gasket 2" Connections	800080B	800080B	800080B	800080B
18-H	Rear Drain Plug & Cover	005264F	005264F	005264F	005264F
J	CONTROL BOX				
1-J	Ignition Control IID Nat.	004817B	004817B	004817B	004817B
	Ignition Control IID Pro.	004818B	004818B	004818B	004818B
2-J	Transformer 120/240/24V	005345F	005345F	005345F	005345F
3-J	Rocker Switch (MV Units)	650902	650902	650902	650902
4-J	Rocker Switch (IID Units)	650903	650903	650903	650903

*FOR ALTITUDES ABOVE 2,000 FEET LEVEL, CONSULT THE FACTORY

CALL OUT	DESCRIPTION	185	265	335	405
M	MISCELLANEOUS COMPONENTS				
1-M	Pressure Switch	062237B	062237B	062237B	062237B
2-M	Pressure Switch Tube Assy.	005392F	005392F	005392F	005392F
3-M	Thermostat Knob (1)	800303	800303	800303	800303
4-M	Knobstop (1)	305138	305138	305138	305138
5-M	Thermal Fuse	005899F	005899F	005899F	005899F
6-M	PRV 125 PSI (Optional)	500648	500038	500038	500038
7-M	Delimiting Kit	052871F	052871F	052871F	052871F
8-M	Wire/Harness STD	005269F	005269F	005269F	005269F
	Wire/Harness IID	005270F	005270F	005270F	005270F
9-M	LED's (2 GRN/2 Red)	005271F	005271F	005271F	005271F
10-M	Control Panel MV	005291F	005291F	005291F	005291F
11-M	Control Panel IID	005292F	005292F	005292F	005292F
12-M	Thermostat Shaft MV	800307	800307	800307	800307
13-M	Thermostat Shaft IID	800304	800304	800304	800304
14-M	CPVC Adapter	005393F	005393F	005393F	005393F
P	PILOT				
1-P	Pilot Nat. MV	600525B	600525B	600525B	600525B
	Pilot Pro. MV	600575B	600575B	600575B	600575B
3-P	Pilot Nat. IID	002003F	002003F	002003F	002003F
	Pilot Pro. IID	002064F	002064F	002064F	002064F
5-P	Pilot Orifice Nat. MV	003901F	003901F	003901F	003901F
	Pilot Orifice Pro. MV	003902F	003902F	003902F	003902F
7-P	Pilot Orifice Nat. IID	003903F	003903F	003903F	003903F
	Pilot Orifice Pro. IID	004308F	004308F	004308F	004308F
9-P	Pilot Generator MV	600019B	600019B	600019B	600019B
12-P	Ignition Control IID Nat.	004817B	004817B	004817B	004817B
	Ignition Control IID Pro.	004818B	004818B	004818B	004818B
13-P	Pilot MTG Bracket MV	306693	306693	306693	306693
14-P	Pilot MTG Bracket IID	306692	306692	306692	306692
15-P	Lighter Tube (MV Units Only)	062996	062996	062996	062996
16-P	Pilot Tube	004078F	004078F	004078F	004078F
17-P	Hi Tension Wire IID	002654B	002654B	002654B	002654B
18-P	Pilot Shield	307223	307223	307223	307223
R	REFRACTORY				
1-R	Refractory Common (Left & Right)	005282F	005282F	005282F	005282F
2-R	Refractory Uncommon (Front & Rear)	005283F	005284F	005285F	005286F
3-R	Refractory Retainer Kit	005287F	005288F	005289F	005290F
S	SHEETMETAL				
1-S	Jacket Top (Louvered)	005303F	005304F	005305F	005306F
2-S	Flue Collector	005307F	005308F	005309F	005310F
3-S	Door Assy.	005315F	005316F	005317F	005318F
4-S	Access Panel Set (3 Pcs.)	005277F	005277F	005277F	005277F
5-S	Side Panel Right	005300F	005300F	005300F	005300F
6-S	Side Panel Left	005301F	005301F	005301F	005301F
7-S	Side Panel Cap	005302F	005302F	005302F	005302F
8-S	Rear Panel Kit (2 Pcs.)	005278F	005279F	005280F	005281F
9-S	Sub-Base for Combustible Flooring	005182	005183	005184	005185
10-S	High Limit Cover	005294F	005294F	005294F	005294F
11-S	Poolstat Cover/Lock	005198	005198	005198	005198
12-S	Up-Front Control Panel	005394F	005395F	005396F	005397F
V	VENTING				
1-V	Indoor Stack Kit (Includes inner adapter panel)	005102	005103	005104	005105
3-V	"Pagoda" Top	065310	065312	065336	065311

CONVERSION KITS**	185B	265B	335B	405B
Gas Conversions				
Nat. to Pro. MV Pilot	004690B	004690B	004692B	004692B
Pro. to Nat. MV Pilot	005319F	005319F	005320F	005320F
Nat. to Pro. IID Pilot	N/A	N/A	N/A	N/A
Pro. to Nat. IID Pilot	N/A	N/A	N/A	N/A

** Gas conversions are to be done only by a qualified agency.

LIMITED WARRANTY
RAYPAK RESIDENTIAL SWIMMING POOL AND SPA HEATERS
GAS MODELS 185, 265, 335 & 405 MILLIVOLT
185, 265, 335 & 405 ELECTRONIC

GENERAL

Raypak, Inc. warrants that the cabinet, burner tray (minus controls) and refractory will be free from defects in materials and workmanship under normal use and service for a period of **FIVE YEARS FROM THE DATE OF ORIGINAL PURCHASE FOR A SINGLE FAMILY RESIDENCE (ONE YEAR IF OTHER THAN FOR SINGLE FAMILY RESIDENCE USE)**. All other parts of this product are warranted by Raypak to be free from defects in materials and workmanship under normal use and service for a period of **TWO YEARS FROM THE DATE OF ORIGINAL PURCHASE FOR A SINGLE FAMILY RESIDENCE (ONE YEAR IF OTHER THAN FOR SINGLE FAMILY RESIDENCE USE)**. In accordance with the terms of this warranty, we will furnish a Raypak replacement for any defective part or repair the part at our option. The replacement or repair will be warranted for only the unexpired portion of the original warranty. Labor costs for removal or reinstallation of parts are not covered by this warranty, nor are shipping charges to or from Raypak's designated repair center. This warranty does not cover rusting or corrosion on cabinet or burners that does not affect heater's operation.

WARRANTY CONDITIONS

This warranty applies only to the heater at its original place of installation. This warranty will be void if the heater is installed in violation of applicable local codes and ordinances or if the rating plate or serial number is altered or removed.

WARRANTY EXCLUSION

This warranty does not cover defects or malfunctions resulting from:

1. *Failure to properly install, operate or maintain the heater in accordance with our printed instructions;*
2. *Abuse, alteration, accident, fire, flood, freeze and the like;*
3. *Misuse or neglect, including but not limited to, freeze-ups, operating the heater with the cabinet door off, having flow restrictions or obstructions between the heater outlet and the pool/spa, or not maintaining a proper chemical balance (PH level must be between 7.4 and 7.8 and total alkalinity between 100 and 150 PPM. Total dissolved solids (TDS) must be no greater than 3000 PPM);*
4. *Use of non-factory authorized accessories or other components in conjunction with the heater.*

HOW TO MAKE A CLAIM

Immediately notify the dealer from whom the heater was purchased, supplying model and serial numbers of the unit, date of purchase, and a description of the problem. The dealer should then promptly contact Raypak about the warranty claim, and for the location of Raypak's nearest designated repair center. (If the dealer for any reason is not available, call or write Raypak directly at the address shown below, Attention: Warranty Service). After such notification has been given and Raypak has advised the location of its designated repair center (which may be the dealer), bring or ship, transportation prepaid, the defective part for replacement or repair to the designated repair center. However, Raypak reserves the right at all times to inspect the claimed defect and verify warranty coverage at its factory.

MISCELLANEOUS

No one is authorized to make any other warranties on our behalf, ANY IMPLIED WARRANTIES, INCLUDING MERCHANTABILITY OR FITNESS FOR A PARTICULAR PURPOSE, SHALL NOT EXTEND BEYOND THE APPLICABLE WARRANTY PERIODS SPECIFIED ABOVE. RAYPAK'S SOLE LIABILITY WITH RESPECT TO ANY DEFECT SHALL BE AS SET FORTH IN THIS WARRANTY AND ANY CLAIMS FOR INCIDENTAL OR CONSEQUENTIAL DAMAGES (INCLUDING DAMAGE FROM WATER LEAKAGE) ARE EXCLUDED. Some states do not allow limitations on how long an implied warranty lasts, or for the exclusion of incidental or consequential damages, so the above limitation or exclusion may not apply to you.

We suggest you immediately complete the information below and retain this Warranty Certificate in the event warranty service is needed. Reasonable proof of the effective date of the warranty must be presented; otherwise, the effective date will be based upon the date of manufacture plus THIRTY (30) Days.

This Warranty gives you specific legal rights, and you may also have other rights which vary from state to state.

_____	_____
Name of Owner	Name of Dealer
_____	_____
Address	Address
_____	_____
Model No.	Serial No.
_____	_____
Date of Purchase _____	

RAYPAK, INC., 31111 Agoura Road, Westlake Village, CA 91361-4699 (818) 889-1500 FAX (818) 889-4522 Litho in U.S.A.