

OPERATING AND INSTALLATION INSTRUCTIONS

VERSA

ABOVE-GROUND POOL
AND SPA HEATER

Model
105B Cast Iron

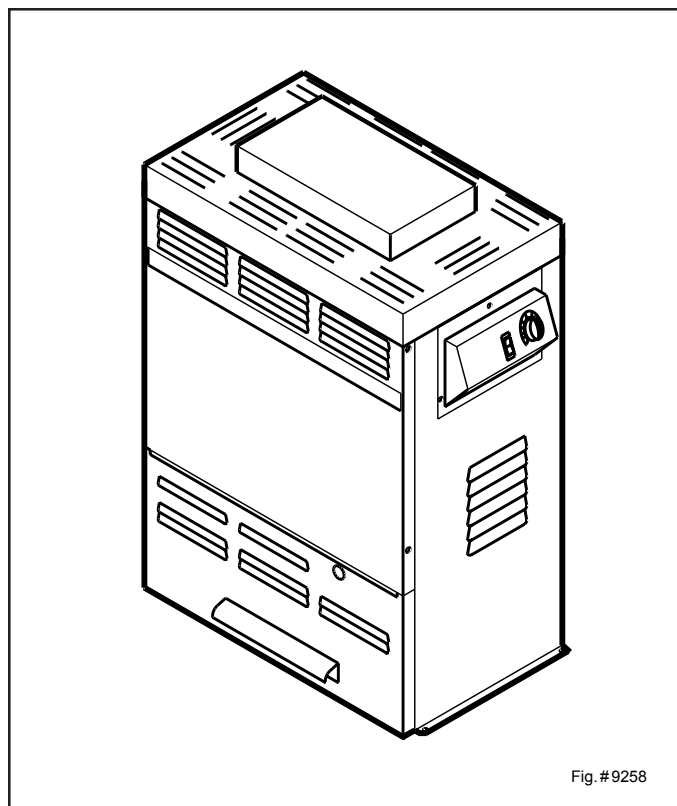

WARNING: If the information in these instructions is not followed exactly, a fire or explosion may result causing property damage, personal injury or death.

- Do not store or use gasoline or other flammable vapors and liquids in the vicinity of this or any other appliance.
- **WHAT TO DO IF YOU SMELL GAS**
 - Do not try to light any appliance.
 - Do not touch any electrical switch; do not use any phone in your building.
 - Immediately call your gas supplier from a neighbor's phone. Follow the gas supplier's instructions.
 - If you cannot reach your gas supplier, call the fire department.
- Installation and service must be performed by a qualified installer, service agency or the gas supplier.

This manual should be maintained in legible condition and kept adjacent to the heater or kept in a safe place for future reference.



WATER CHEMISTRY
(Corrosive water voids all warranties)

For your health and the protection of your pool equipment, it is essential that your water be chemically balanced. The following levels must be used as a guide for balanced water.

Recommended Level(s)	Fiberglass Pools	Fiberglass Spas	Other Pool & Spa Types
Water Temp. (Deg. F)	68 to 88	89 to 104	68 to 104
pH	7.3 to 7.4	7.3 to 7.4	7.6 to 7.8
Total Alkalinity (PPM)	120 to 150	120 to 150	100 to 150
Calcium Hardness (PPM)	200 to 300	150 to 200	80 to 100
Salt (PPM)	6000 MAXIMUM	6000 MAXIMUM	6000 MAXIMUM
Free Chlorine (PPM)*	2 to 3	2 to 3	2 to 3

*** Free Chlorine MUST NOT EXCEED 5 PPM!**

- Occasional chemical shock dosing of the pool or spa water should not damage the heater providing the water is balanced.
- Automatic chemical dosing devices and salt chlorinators are usually more efficient in heated water, unless controlled, they can lead to excessive chlorine level which can damage your heater.
- Further advice should be obtained from your pool or spa builder, accredited pool shop, or chemical supplier for the correct levels for your water.

Contents

4 PART ONE - Owner's Operating Instructions

4 SECTION 1 / START-UP PROCEDURES

- 4 Before Start-Up
- 5 Lighting Instructions & Shut-Off Procedures
(manually lighted pilot MV)
- 6 Lighting Instructions & Shut-Off Procedures
(automatically lighted pilot IID)
- 7 After Start-Up

7 SECTION 2 / CAUTION

7 SECTION 3 / MAINTENANCE & CARE PROCEDURES

- 8 Pool & Spa Water Chemistry
- 8 Winterizing the Pool and Spa Heater

9 PART TWO - Installation / Service Instructions

9 SECTION 1 / RECEIVING EQUIPMENT

9 SECTION 2 / GENERAL SPECIFICATIONS

9 SECTION 3 / INSTALLATION INSTRUCTIONS

- 9 Code Requirements
- 9 Base Installation
- 10 Clearances
- 11 Combustion Air
- 11 Venting Connections
- 14 Gas Supply Connections
- 15 Plumbing for Water Connections
- 16 Electrical Wiring

21 SECTION 4 / SERVICING INSTRUCTIONS

- 21 General Location of Controls
- 21 Control Adjustments / Replacements
- 21 Pressure Switch
- 22 High Limit
- 22 Pilot Safety
- 23 Burner tray Removal
- 23 Gas Valve Removal
- 23 Main Burner & Orifice Removal
- 23 Pilot Removal & Cleaning
- 23 Heat Exchanger Removal
- 24 Tube Cleaning Procedure
- 24 Tube Replacement Procedure
- 24 Desooting Procedure
- 24 Combustion Chamber Removal

25 SECTION 5 / TROUBLESHOOTING GUIDE

- 25 Mechanical
- 26 Electrical MV Units
- 27 Electrical IID Units

28 SECTION 6 / REPLACEMENT PARTS

PART 1 - OWNER'S OPERATING INSTRUCTIONS

FOR YOUR SAFETY - READ BEFORE OPERATING
WARNING: IF YOU DO NOT FOLLOW THESE
INSTRUCTIONS EXACTLY, A FIRE OR EXPLOSION
MAY RESULT, CAUSING PROPERTY DAMAGE,
PERSONAL INJURY OR LOSS OF LIFE.

SECTION 1 START-UP PROCEDURES

BEFORE START-UP

BURNERS

Clean main burners and air louvers of dust, lint and debris. Keep heater area clear and free from combustibles, flammable liquids and chemicals. Do not obstruct the flow of combustion and ventilation air.

WATER

First ensure that system is filled with water and have pump operating. Water must be flowing through the heater during operation.

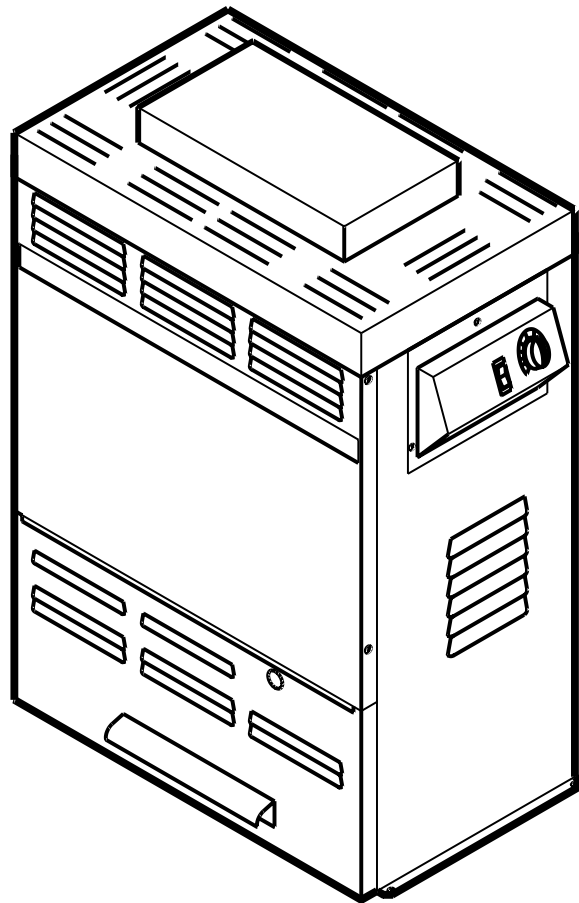

Fig. #9258

CAUTION: Propane gas is heavier than air and will settle on the ground. Since propane can accumulate in confined areas, extra care should be exercised when lighting propane heaters.

LIGHTING INSTRUCTIONS AND SHUT-OFF PROCEDURES

MANUALLY LIGHTED PILOTS (MILLIVOLT SYSTEM)

- A. This appliance has a pilot that must be lighted by hand. When lighting the pilot, follow these instructions exactly.
- B. BEFORE LIGHTING smell all around the appliance area for gas. Be sure to smell next to the floor because some gas is heavier than air and will settle on the floor.

WHAT TO DO IF YOU SMELL GAS:

- *Do not try to light any appliance.
- *Do not touch any electric switch; do not use any phone in your building.
- *Immediately call your gas supplier from a neighbor's phone. Follow the gas supplier's instructions.

*If you cannot reach your gas supplier, call the fire department.

C. Use only your hand to push in or turn the gas control knob. Never use tools. If the knob will not push in or turn by hand, do not try to repair it. Call a qualified service technician. Force or attempted repair may result in a fire or explosion.

D. Do not use this appliance if any part has been under water. Immediately call a qualified service technician to inspect the appliance and to replace any part of the control system and any gas control which has been under water.

LIGHTING INSTRUCTIONS

1. **STOP!** Read the safety information above.
2. Set the thermostat on the lowest setting.
3. Turn On/Off switch to the "Off" position.
4. Remove heater door panel.
5. Push in gas control knob slightly and turn clockwise  to "Off".

NOTE: Knob cannot be turned from "Pilot" to "Off" unless knob is pushed in slightly. Do not force.

6. Wait 5 minutes to clear out any gas. If you then smell gas, **STOP!** Follow "B" in the safety information above. If you don't smell gas, go to the next step.
7. Locate pilot mounted on the right side panel of the burner tray. For burner tray location, see location of control section, page 18.

Gas control knobs shown in "Off" position

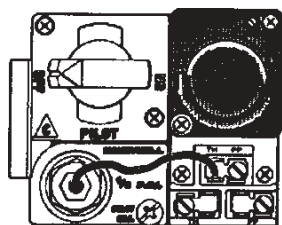

HONEYWELL
GAS VALVE
MILLIVOLT

Fig. #8081.0

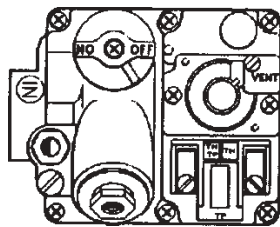

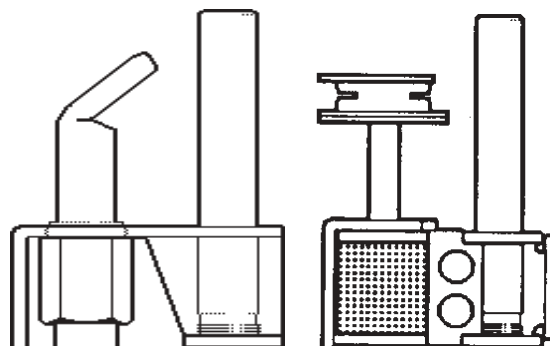

ROBERTSHAW
GAS VALVE
MILLIVOLT

Fig. # 8199



ROBERTSHAW PILOT
Fig. #8084.0

HONEYWELL PILOT
Fig. #8083.0

8. Turn knob on gas control counter-clockwise  to "Pilot".
9. Push in control knob all the way and hold in. Immediately place flame to pilot to light. Continue to hold control knob in for about 1 minute after the pilot is lighted, release knob and it will pop back up. Pilot should remain lighted. If it goes out, repeat steps 5 through 9.
 - *If knob does not pop up when released, stop and immediately call your service technician or gas supplier.
 - *If the pilot does not stay lit after several tries, turn the gas control knob to "Off" and call your service technician or gas supplier.
10. Stand to the side of the heater and turn the gas control knob counter-clockwise to  "On".
11. Replace heater door panel.
12. Turn On/Off switch to the "On" position.
13. Set thermostat to the desired setting.

TO TURN OFF GAS TO APPLIANCE

1. Set the thermostat to the lowest setting.
2. Turn On/Off switch to the "Off" position.
3. Remove heater door panel.
4. Push the gas control knob slightly and turn clockwise to  "Off". Do not force.
5. Replace heater door panel.

CAUTION: Propane gas is heavier than air and will settle on the ground. Since propane can accumulate in confined areas, extra care should be exercised when lighting propane heaters.

OPERATING INSTRUCTIONS AND SHUT-OFF PROCEDURES AUTOMATICALLY LIGHTED PILOTS (ELECTRONIC IGNITION SYSTEMS)

- A. This appliance is equipped with an ignition device which automatically lights the pilot. Do not try to light the pilot by hand.
- B. BEFORE OPERATING, smell all around the appliance area for gas. Be sure to smell next to the floor because some gas is heavier than air and will settle on the floor.



WHAT TO DO IF YOU SMELL GAS:

- *Do not try to light any appliance.
- *Do not touch any electric switch; do not use any phone in your building.
- *Immediately call your gas supplier from a neighbor's phone. Follow the gas supplier's instructions.

*If you cannot reach your gas supplier, call the fire department.

- C. Use only your hand to push in or turn the gas control knob. Never use tools. If the knob will not push in or turn by hand, do not try to repair it; call a qualified service technician. Force or attempted repair may result in fire or explosion.
- D. Do not use this appliance if any part has been under water. Immediately call a qualified service technician to inspect the appliance and to replace any part of the control system and any gas control which has been under water.

OPERATING INSTRUCTIONS

1. **STOP!** Read the safety information above.
2. Set the thermostat to the lowest setting.
3. Turn off all electric power to the appliance.
4. This appliance is equipped with an ignition device which automatically lights the pilot. Do not try to light the pilot by hand.
5. Remove heater door panel.
6. Turn gas control knob clockwise  to "Off".
7. Wait 5 minutes to clear out any gas. If you then smell gas, **STOP!** Follow "B" in the safety information above. If you don't smell gas, go to the next step.
8. Turn gas control knob counter-clockwise  to "On".
9. Replace heater door panel.
10. Turn on all electrical power to appliance.
11. Set thermostat to desired setting.
12. If the appliance will not operate, follow the instructions "To Turn Off Gas To Appliance" and call your service technician or gas supplier.

Gas control knob shown in "ON" position.

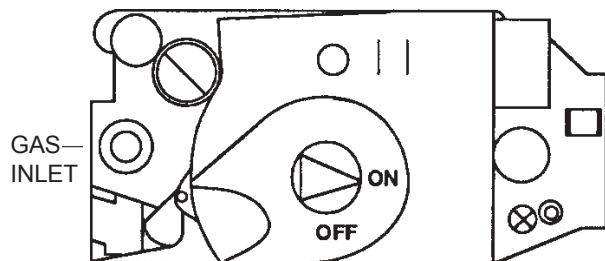

HONEYWELL VR8300 GAS VALVE IID

TO TURN OFF GAS TO APPLIANCE

1. Set the thermostat at the lowest setting.
2. Turn off all the electric power to the appliance if service is to be performed.
3. Remove heater door panel.
4. Turn gas control knob clockwise  to "Off". Make sure knob rests against stop.
5. Replace heater door panel.

AFTER START-UP

Feel the inlet and outlet pipes. Outlet pipe should be only slightly warmer than the inlet. It should not be hot.

WARNING: *Should overheating occur or the gas supply fail to shut-off, turn off the manual gas control valve to the appliance.*

VISUAL INSPECTION

With the heater on, remove the door and make a visual check of the pilot and burner.

The flame should be blue with a well-defined pattern.

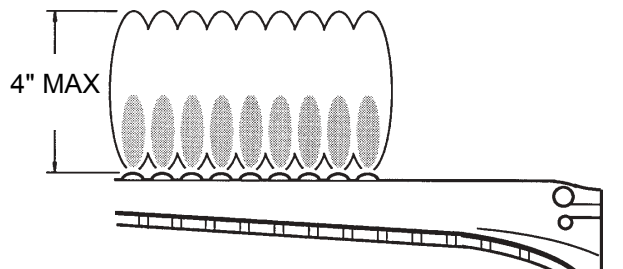

Fig. # 8144.1

MAIN BURNER FLAME

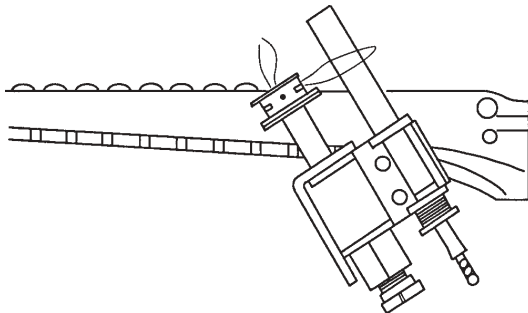

Fig. # 8958

PILOT BURNER FLAME

A yellow or "floating" flame indicates restricted air openings or incorrect orifice size. Should this occur, shut the heater off and contact your installer or gas supplier.

WATER PRESSURE SWITCH

A water pressure switch is provided in the heater to shut-off the burners in the event that water supply to the heater is interrupted. It is very important to verify that the switch electrically opens and shuts off the gas valve when water flow to the heater is interrupted. Otherwise, rapid and severe damage will likely occur to the heater. (The water pressure switch should be checked and adjusted for proper operation by a qualified service person at the time of installation and periodically checked thereafter. Refer to pressure switch servicing instruction in Section 4 of this manual.)

WARNING: *Operation of the heater without water circulation will cause rapid and severe damage to the heater.*

SECTION 2 CAUTION

Elevated water temperature can be hazardous, and the U.S. Consumer Product Safety Commission recommends the following guidelines:

1. Spa or hot tub water temperatures should never exceed 104°F (40°C). A temperature of 100°F (38°C) is considered safe for a healthy adult. Special caution is suggested for young children.
2. Drinking of alcoholic beverages before or during spa or hot tub use can cause drowsiness which could lead to unconsciousness and subsequently result in drowning.
3. *Pregnant women beware!* Soaking in water over 102°F (39°C) can cause fetal damage during the first three months of pregnancy, including in brain damage or deformity. Pregnant women should observe the 100°F (38°C) maximum rule.
4. Before entering the spa or hot tub, users should check the water temperature with an accurate thermometer; spa or hot tub thermostats may err in regulating water temperatures by as much as four degrees Fahrenheit (2.2°C).
5. Persons with a medical history of heart disease, circulatory problems, diabetes, or blood pressure problems should obtain a physician's advice before using pools or hot tubs.
6. Persons taking medications which induce drowsiness, such as tranquilizers, antihistamines, or anticoagulants, should not use spas or hot tubs.

SECTION 3 MAINTENANCE AND CARE PROCEDURES

To be followed one month after start-up and then semi-annually.

1. Inspect top of heater and draft hood for soot, a sticky black substance around fin tube, baffle and open flue gas passageways.

CAUTION: *Soot may be combustible. Wet sooted surfaces completely prior to cleaning. Do not use steel wire brush.*

2. Clean main burners and pilot burner of dust and lint.
3. Inspect and operate all controls, gas valve and pressure relief valve.

4. Make visual check of the burner and pilot flame. Flame pattern on the main burner and pilot is indicated in the previous illustration. Yellow flame means restriction of the air openings. Liftin or blowing flame indicates high gas pressure. Low flame means low gas pressure. Should this occur, shut the heater off and contact your gas supplier or qualified service agency.
5. On indoor heaters, clean room intake openings to ensure adequate flow of combustion and ventilation air.

CAUTION: Combustion air must not be contaminated with corrosive chemical fumes which can damage the heater.

6. Keep area around heater clear and free from combustible materials and other flammable and corrosive vapors and liquids.

IF HEATER WILL NOT FIRE:

If you have no electrical power:

1. It may be your "circuit breakers" have tripped. Try re-setting them.

If you have electrical power but the heater will not fire check the following:

1. The time clock must be moved to the "ON" position.
2. Your pump strainer basket may be full. If so, remove debris.
3. Your filter may be dirty. If so, backwash or clean filter. (If your filter is dirty, the gauge pressure will be higher than usual).
4. The pump may have lost its prime. It may be running dry. Check the pressure gauge on the filter. If there is no pressure, then the water is not circulating (or the pressure gauge is broken). Try to get the pump to run at its normal flow rate.

POOL & SPA WATER CHEMISTRY

Chemical imbalance can cause severe damage to your heater and associated equipment. Maintain your water chemistry according to the chart on page 2. If the mineral content and dissolved solids in the water become too high, scale forms inside the heat exchanger tubes, reducing heater efficiency and also damaging the heater. If the pH drops below 7.2, the heater will be severely damaged. This will result in corrosion of the heat exchanger. Heat exchanger damage resulting from chemical imbalance is not covered by the warranty.

COLDWEATHER OPERATION

Heater operation can continue during short term cold spells. When temperatures are below freezing, flow (continuous pump operation) must be maintained.

CAUTION: Do not use the heater to maintain water temperatures just above freezing or for freeze protection. When heaters are used during freezing weather, care must be taken to avoid freeze-ups. Continuous pump operation is a must. Additional protection may be required. The heater is not warranted against freeze-ups.

Prolonged operation with water temperatures below 50°F is not recommended. When starting the heater with pool temperatures below 50°F, operate the heater continuously until higher temperatures are reached. Operating the heater for prolonged periods with pool water below 50°F can seriously damage the heater, and is not covered by the warranty.

For cold climate areas please follow the winterizing procedures listed below.

WINTERIZING THE SPA HEATER

When heaters installed outdoors in freezing climate areas are to be shut down for the winter, observe the following procedure:

1. Turn off gas valve, manual gas valve, and electrical supply to the heater.
2. Open drain cock located on the inlet/outlet header, (under water pipes). Remove drain changer inspection panels on the side opposite water piping to gain access to the plug on the return header.

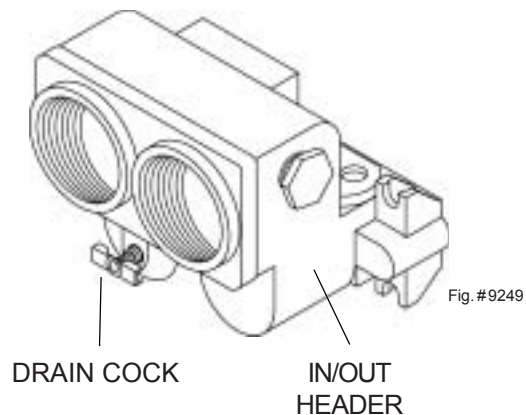

PART 2 - INSTALLATION / SERVICE INSTRUCTIONS

SECTION 1 RECEIVING EQUIPMENT

On receipt of your equipment, visually check for external damage to the carton. If the carton is damaged, a note should be made on the Bill of Lading when signing for equipment. Remove the heater from the carton and if it is damaged, report the damage to the carrier immediately.

Some items are shipped loose. Be sure that you receive the number of packages indicated on the Bill of Lading.

When ordering parts, you must specify model and serial number of heater. When ordering under warranty conditions, you must also specify date of installation.

The manufacturer recommends that this manual be reviewed thoroughly before installing your heater. If there are any questions that this manual does not answer, please contact the factory or your local representative.

SECTION 2 GENERAL SPECIFICATION

These heaters are designed, certified and tested under the requirements of ANSI Z21.56/CSA 4.7 American National Standard/CSA Standard for Gas-Fired Pool Heaters.

The heater can be installed either indoors or outdoors. The appropriate top designated for that type of use is required. If desired, the top can be changed at a later date to change from outdoor to indoor or vice versa. Millivolt heaters contain a self-generating electrical system operating between .25 and .75 volts.

AMBIENT TEMPERATURE RATING OF HEATER COMPONENTS

Millivolt Heater with Honeywell Gas Valve
32°F to 175°F

Millivolt Heater with Robertshaw Gas Valve
0°F to 175°F

Electronic Ignition Heaters*
-32°F to 175°F

*Requires 120V or 240V power supply

Rated inputs suitable for up to 2000 feet elevation. For elevations above 2000 feet, reduce input 4% for each 1000 feet above sea level, as high elevation reduces combustion performance. For Canada, no deration is required for elevations up to 4500 feet.

SECTION 3 INSTALLATION INSTRUCTIONS

CALIFORNIA PROPOSITION 65 WARNING:

This product contains chemicals known to the State of California to cause cancer, birth defects or other reproductive harm.

IMPORTANT NOTICE

These instructions are intended for the use of qualified personnel only, specifically trained and experienced in the installation of this type of heating equipment and related system components. Installation and service personnel may be required by some states to be licensed. If your state is such, be sure your contractor bears the appropriate license. Persons not qualified shall not attempt to fix this equipment nor attempt repairs according to these instructions.

WARNING: *Improper installation, adjustment, alteration, service or maintenance may damage the equipment, create a hazard resulting in asphyxiation, explosion or fire, and will void the warranty.*

CODE REQUIREMENTS

NOTE: *The heater should not be located in an area where possible water leakage will result in damage to the area adjacent to the appliance or to the structure. When such locations cannot be avoided, it is recommended that a suitable drain pan, adequately drained, be installed under the appliance. The pan must not restrict combustion air flow.*

Installation must be in accordance with local codes, or, in the absence of local codes, with the latest editions of the National Fuel Gas Code, ANSI Z223.1, and the National Electrical Code, ANSI/NFPA 70, and for Canada, the latest edition of CAN/CGA-B149.1 and B149.2, and Canadian Electrical Code, CSA C22.1 Part 1 and Part 2.

BASE INSTALLATION

Heater must be mounted on a level surface. It can be installed on combustible flooring. Heaters must not be installed on carpeting.

WARNING: Do not install within 3 feet of a Heat Pump or an outdoor condensing unit. Strong air intake from this equipment can disturb the combustion process and cause damage or personal injury.

CLEARANCES

Clearances from combustible construction:

Indoor Installation

Top* (Drafthood) - 30"; Vent - 6";
Back - 5"; Right Side - 6";
Left Side - 6"; Floor - 0".

Outdoor Installation

Top* (Stackless Top) - unobstructed;
Back - 5"; Sides - 6".

* Clearance from Top of Vent Terminal

For servicing, provide at least 24" in front of the heater for burner tray removal, and at least 18" on the left side of the heater to inspect and delime the heat exchanger.

OUTDOOR HEATERS

These heaters are design certified for outdoor installation, when equipped with the approved top designated for outdoor use.

WARNING: *The heater shall not be located in an area where water sprinklers, or other devices, may cause water to spray through the cabinet louvers and into the heater. This could cause heavy internal rusting or damage some electrical components, and this would void the warranty.*

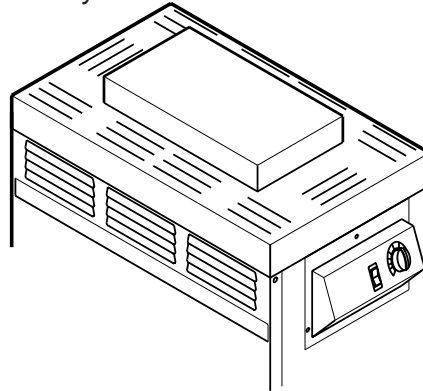

Heater with outdoor top

Fig # 9259

Heaters must not be installed under an overhang within three (3) feet from the top of the heater. Three (3) sides must be open in the area under the overhang. Roof water drainage must be diverted away from the heater with the use of gutters:

For U.S. installations, the point from where the flue products exit the heater must be a minimum of four (4) feet below, four (4) feet horizontally from, or one (1) foot above any door, window or gravity inlet to a building. The top surface of the heater shall be at least three (3) feet above any forced air inlet, or intake ducts located within ten (10) feet horizontally.

For installations in Canada, pool heaters shall not be installed with the top of the vent assembly within 10 feet below, or to either side, of any opening into the building. Refer to the latest revision of CAN/CGA-B149.1 and B149.2.

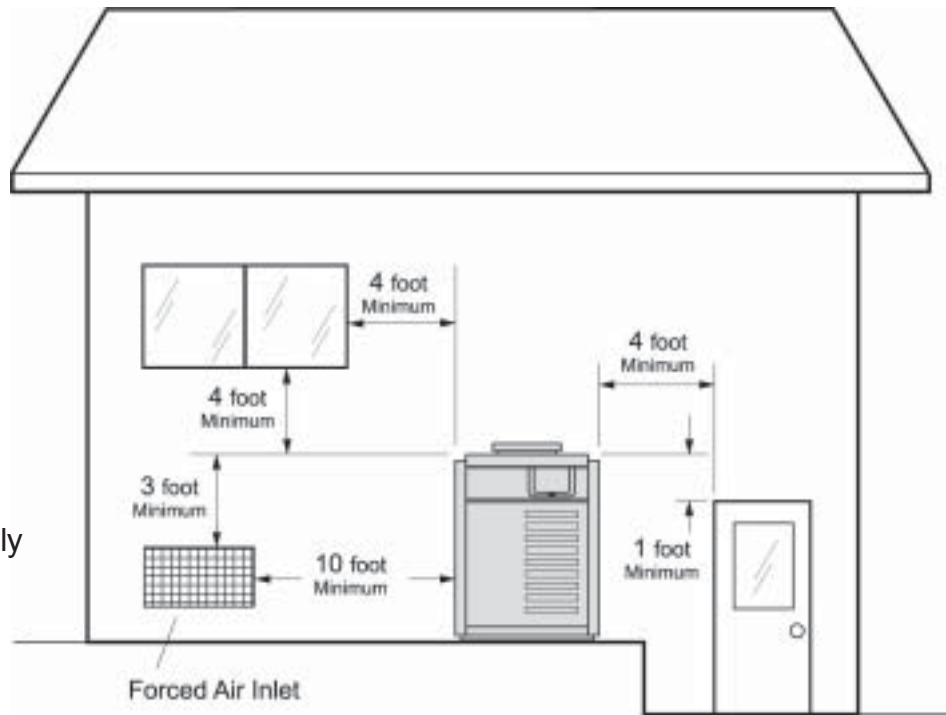

U.S. Installations Only

Fig.#8245.1

HIGH-WIND CONDITIONS (OUTDOOR UNITS ONLY)

In areas where high winds are frequent, it may be necessary to locate the heater a minimum of 3' from high vertical walls, or install a wind break so the heater is not in direct wind current.

In areas of daily high winds, it may be necessary to replace the outdoor stackless top with a stack adapter in combination with a wind resistant/weatherproof outdoor stack. See illustration below.

The outdoor stack serves the same function as the low profile stackless top and should be installed in accordance with the same clearance requirements.

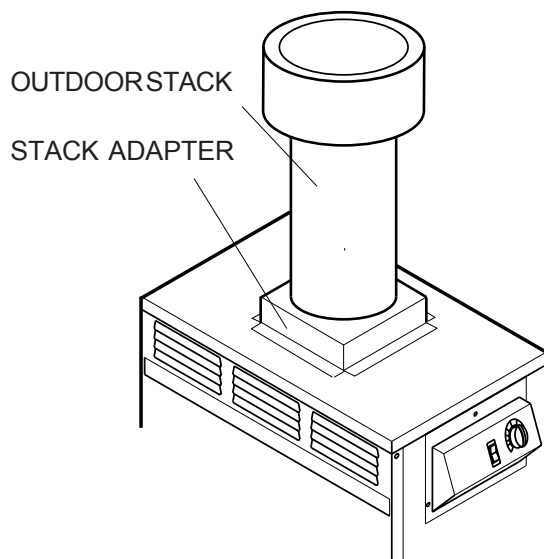

Fig#9253

INDOOR HEATERS

The design is also certified for indoor installation when equipped with the approved draft hood. For Canada, indoor installation is restricted to an enclosure that is not occupied and does not directly communicate with occupied area. Refer to the latest edition of CAN/CGA-B149.1 and -B149.2 for specific requirements. Locate heater as close as practical to a chimney or gas vent. Heater must always be vented to the outside. See Vent Piping Section for venting details. Minimum allowable space is shown on the nameplate.

INDOOR TOP

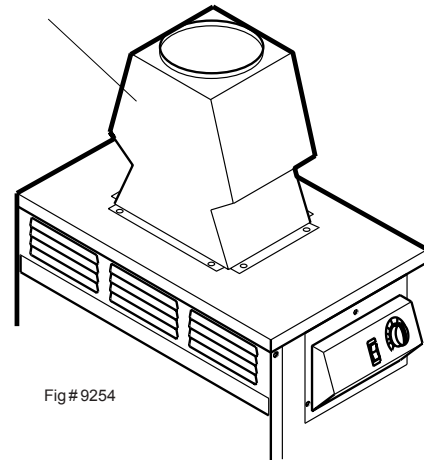

Fig#9254

COMBUSTION AND VENTILATION AIR (INDOOR UNITS ONLY)

The heater must have both combustion and ventilation air. Minimum requirements for net free air supply openings are one 12 inches from ceiling for ventilation and one 12 inches from the floor for combustion air as outlined in the latest edition of the National Fuel Gas Code, Z223.1 (Canada-CAN/CGA-B149.1 and -B149.2) and any local codes that may have jurisdiction.

CAUTION: *Combustion air must not be contaminated by corrosive chemical fumes which can damage the heater and void the warranty.*

- a. All air from inside the building:
Each opening shall have a minimum of 105 net free square inches.
- b. All air from outdoors:
When air is supplied directly from outside of building, each opening shall have a minimum of 27 net free square inches.

VENTING CONNECTIONS

VENT TERMINAL (OUTDOOR) STACKLESS TOP INSTALLATION

- STEP 1: Remove the (4) screws which fasten jacket top to heater.
- STEP 2: Lower outdoor top onto unit lining up slots in outdoor top with screw holes in jacket top.
- STEP 3: Reinstall (4) screws to secure jacket top and outdoor top to unit.

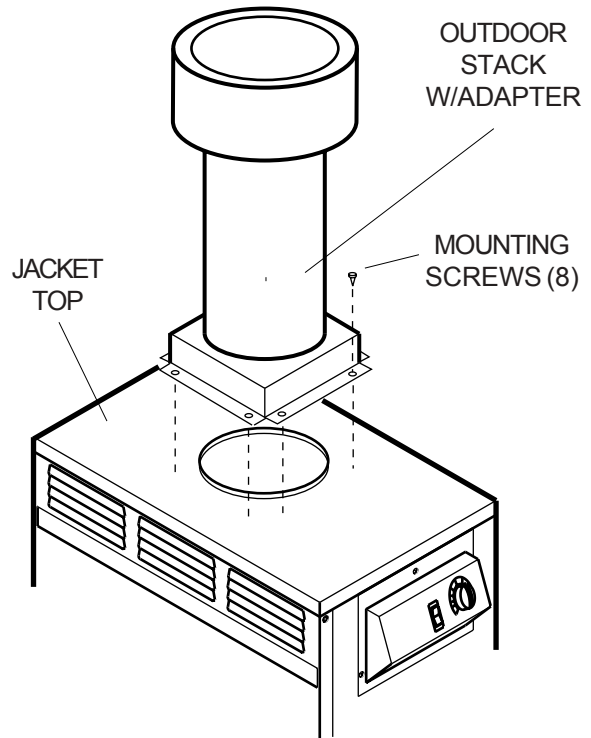
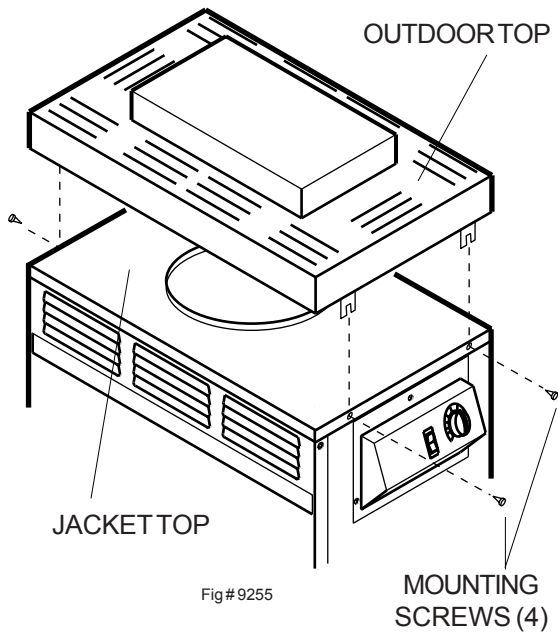

VENT TERMINAL (INDOOR) INSTALLATION

Locate and assemble as shown. Secure with screws supplied in envelope inside carton.

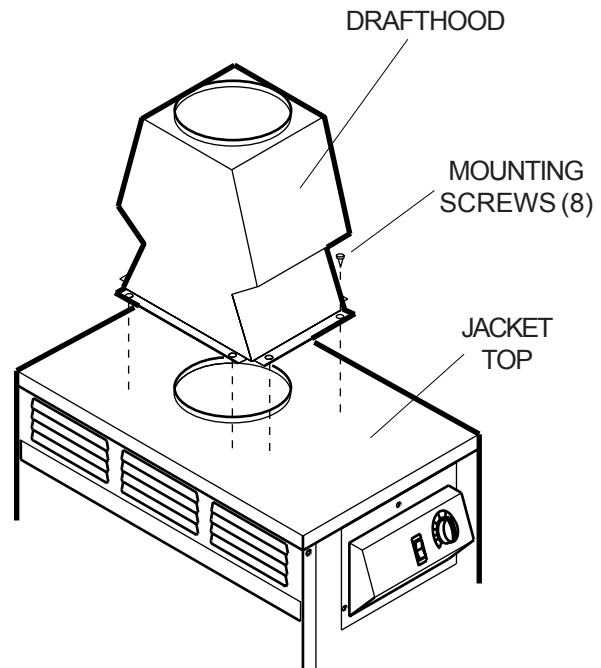

VENT TERMINAL (OUTDOOR) STACK INSTALLATION

- STEP 1: Line up (8) holes in jacket top with (8) holes in adapter assembly.
- STEP 2: Lower entire outdoor stack assembly on to jacket top.
- STEP 3: Secure with fasteners provided.

VENT PIPING

WARNING: *Indoor boilers require a draft hood that must be connected to a vent pipe and properly vented to the outside. Failure to follow this procedure can cause fire or fatal carbon monoxide poisoning.*

Vent piping the same size or larger than the draft hood outlet is recommended, however, when the total vent height is at least 10 feet (draft hood relief opening to vent terminal), the vent pipe size may be reduced as specified in Chapter 10 of the National Fuel Gas Code, ANSI Z 223.1. (Canada-CAN/CGA-B149.1 and B149.2) As much as possible avoid long horizontal runs of vent pipe and too many elbows. If installation requires horizontal or non-vertical runs, the vent pipe must have a minimum of 1/4 inch per foot rise and should be supported at not more than five foot intervals. Plumbers tape, crisscrossed, will serve to space both horizontal and vertical piping. Gas vents supported only by the flashing and extending above the roof more than five feet should be securely guyed or braced to withstand snow and wind loads. We recommend use of insulated vent pipe spacer through the roofs and walls.

For protection against rain or blockage by snow, the vent pipe must terminate with a vent cap which complies with the local codes or, in the absence of such codes, to the latest edition of the National Fuel Gas Code, ANSI Z223.1. (Canada-CAN/CGA-B149.1 and B149.2)

The discharge opening must be a minimum of two feet vertically from the roof surface and at least 2 feet higher than any part of the building within ten feet. Vent stack shall be at least five feet in vertical height above the draft hood outlet. The vent cap location shall have a minimum clearance of 4 feet horizontally from, and in no case above or below, unless a 4-foot horizontal distance is maintained, from electric meters, gas meters regulators and relief equipment.

The weight of the vent stack or chimney must not rest on heater draft hood. Support must be provided in compliance with applicable codes. The heater top and draft hood must be readily removable for maintenance and inspection. Vent pipe should be adequately supported to maintain proper clearances from combustible construction.

Type "B" double wall or equivalent vent pipe is recommended. However single wall metal vent pipe may be used as specified in the latest edition of the National Fuel Gas Code ANSI Z 223.1. (Canada-CAN/CGA-B149.1 and B149.2)

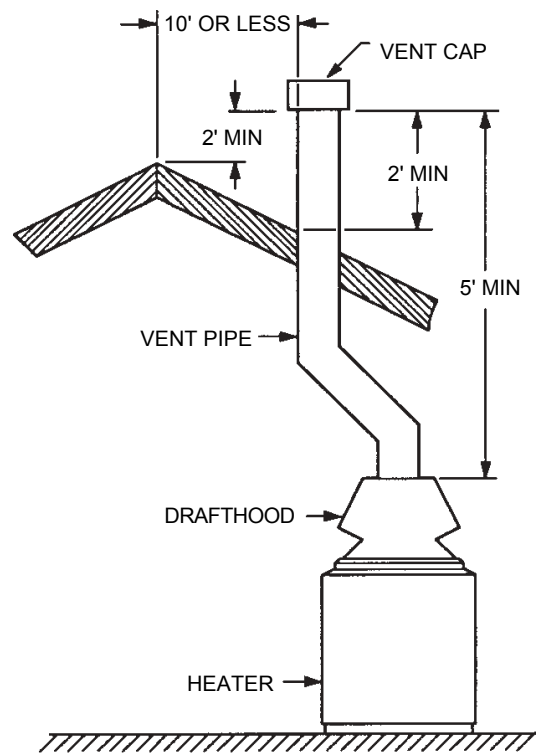
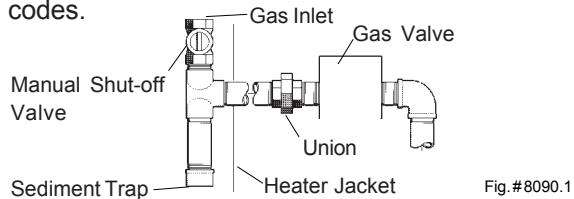

Fig. # 8119.1

GAS SUPPLY CONNECTIONS

Gas piping must have a sediment trap ahead of the heater gas controls, and a manual shut-off valve located outside the heater jacket. All gas piping should be tested after installation in accordance with local codes.



CAUTION: The heater and its manual shut-off valve must be disconnected from the gas supply during any pressure testing of that system at test pressures in excess of 1/2 psig (3.45 KPA). Dissipate test pressure in the gas supply line before reconnecting the heater and its manual shut-off valve to gas supply line. FAILURE TO FOLLOW THIS PROCEDURE MAY DAMAGE THE GAS VALVE. OVER PRESSURED GAS VALVES ARE NOT COVERED BY WARRANTY. The heater and its gas connections shall be leak tested before placing the appliance in operation. Use soapy water for leak test. Do NOT use open flame.

NOTE: Do not use teflon tape on gas line pipe thread. A flexible sealant is recommended.

A minimum of 7" WC and a maximum of 14" WC upstream pressure under load, and no load conditions must be provided for natural gas or a minimum of 12" WC and a maximum of 14" for propane gas.

PIPE SIZING FOR GAS CONNECTIONS

MAXIMUM EQUIVALENT PIPE LENGTH

Natural Gas 1000 BTUH/ FT ³ . 60 Specific Gravity @ 0.5" WC Pressure Drop				
Propane Gas 2500 BTUH/ FT ³ 1.53 Specific Gravity @ 0.5" WC Pressure Drop				
	1/2"		3/4"	
MODEL	Natural	Propane	Natural	Propane
105B	25	55	95	200

GAS PRESSURE REGULATOR

The gas pressure regulator is preset and sealed at 4" WC for natural gas, and 11" WC for propane gas. Between the gas valve and the burners is a 1/8" pipe plug. The pressure at this point, taken with a manometer, should be about 3.7" WC natural gas and 10.5" WC propane gas. If an adjustment is needed, remove seal and turn adjustment screw clockwise to increase pressure or counter-clockwise to decrease pressure.

ROBERTSHAW MV

Gas Pressure Adjustment

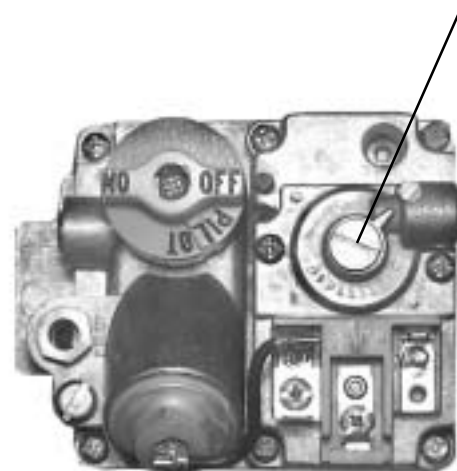

Fig. #9263

HONEYWELL VALVE MV

Gas Pressure Adjustment

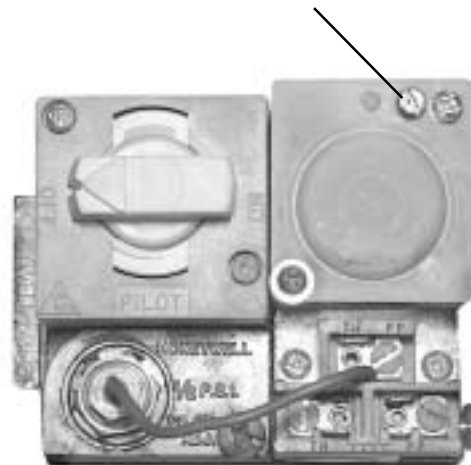

Fig. #9265

HONEYWELL IID VR 8300 GAS VALVE

Gas Pressure Adjustment

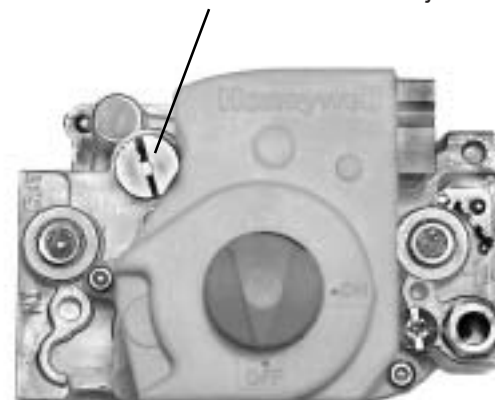

Fig. #9264

PLUMBING FOR WATER CONNECTIONS LOCATION

The heater requires water flow and positive pressure to fire and operate properly. It must therefore be installed downstream of the discharge side of the filter pump. A typical installation is plumbed as follows:

1. The inlet side of the filter is plumbed directly to the discharge side of the filter pump;
2. The outlet side of the filter is then plumbed to the inlet of the heater; and
3. The outlet of the heater is plumbed to the return line to the pool or spa. The pump, filter and heater are thus plumbed in series.

Plumbing from the heater back to the pool must not have any valves or restrictions that could prevent flow when the pump is operating. This would void the warranty.

FLOW RATES

MIN. GPM: 20, MAX. GPM: 115*

*When flow rates exceed 115 GPM, an external auxiliary bypass valve is required. See External Auxiliary Bypass Valve section for details.

CAST IRON HEADER

The inlet/outlet header accepts a 1-1/2" pipe thread. The header will accept either copper and galvanized pipe or CPVC adapters.

CAUTION: *Never install PVC directly into header flanges. The initial connection must be made with high-temperature material such as CPVC or copper.*

FOR IID PILOTS: PVC may be utilized immediately after the initial connections.

FOR STANDING PILOTS: Copper or high-temperature CPVC pipe and two elbows are required between the heater and the PVC connections (heat sinks not supplied).

INLET/OUTLET HEADER

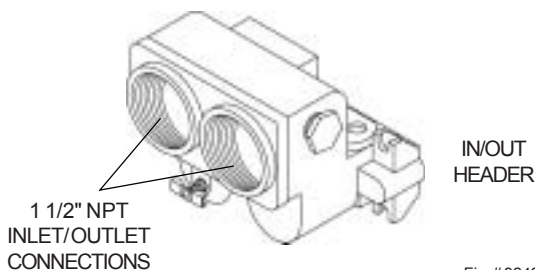

Fig. #9249

AUTOMATIC CHLORINATORS AND CHEMICAL FEEDERS

All chemicals must be introduced and completely diluted into the pool or spa water before being circulated through the heater. Do not place chlorine tablets or bromine sticks in the skimmer. High chemical concentrations will result when the pump is not running (e.g. overnight).

Chlorinators must feed downstream of the heater and have an anti-siphoning device to prevent chemical back-up into the heater when the pump is shut-off.

NOTE: *High chemical concentration from feeders and chlorinators that are out of adjustment will cause very rapid corrosion to the heat exchanger in the heaters. Such damage is not covered under the warranty.*

INTERNAL AUTOMATIC BYPASS VALVE

A built-in automatic bypass valve is provided in the in/out header. The internal bypass valve automatically responds to changes in water pressure in the piping system. Proper amount of water flow is maintained through the heater under varying pressures dictated by the conditions of the pump and filter.



Fig. #8078.0

EXTERNAL AUXILIARY BYPASS VALVE

(Where required)

An auxiliary bypass valve should be used when flow rates exceed 115 GPM (usually a high performance pump size larger than 2 HP will exceed this flow rate). This valve is required to complement the function of the automatic bypass valve, particularly when starting the heater in winter or early spring when the spa or pool temperature is down below 55°F. It also serves to eliminate needless pressure drop through the heater and accompanying reduction in the flow rate to the spa jets, etc.

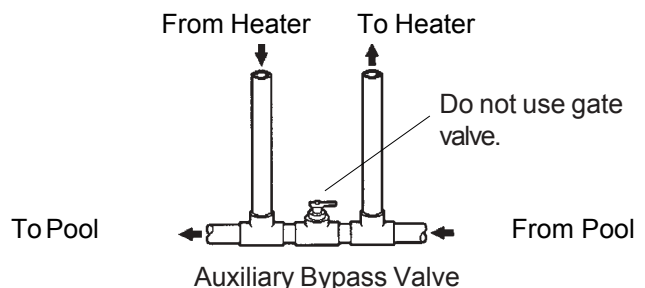

Fig. #8150.

AUXILIARY BYPASS VALVE ADJUSTMENT

To set bypass: With clean filter, adjustment is made by feeling the inlet and outlet pipes at the heater. Outlet pipes should be slightly warmer than inlet and comfortable to the touch. If pipe is hot, close bypass; if cold, open bypass.

ELECTRICAL WIRING

NOTE: *If it is necessary to replace any of the original wiring, it must be replaced with 105 °C wire or its equivalent, except all black wire must be replaced with 150 °C wire or its equivalent.*

MILLIVOLT SYSTEM

The millivolt heater is equipped with a self-generating electrical system in which the electric current is provided by means of a pilot generator. No external electrical connections are required.

When installing a remote switch, do not exceed 10 ft. of wiring from the heater. Use 18-gauge stranded wire.

ELECTRONIC INTERMITTENT IGNITION DEVICE SYSTEM (IID)

NOTE: *When the electrical hookup to the heater requires both 24V and 115V or 240V, each input voltage must be isolated in a separate conduit.*

The electronic intermittent ignition device automatically lights the pilot and main burners upon a call for heat. The heater is supplied with a dual-voltage transformer for 120V or 240V input power hookup.

NOTE: IID Propane Units Only
Heater is equipped with an electronic ignition device with a 100% safety lockout feature. If the heater fails to start or lock out, reset the ignition device by interrupting the power to the heater for 60 seconds.

CAUTION: *If service replacement of the electronic ignition device is required, replace only with a 100% safety lockout device with 90-second trial for pilot ignition.*

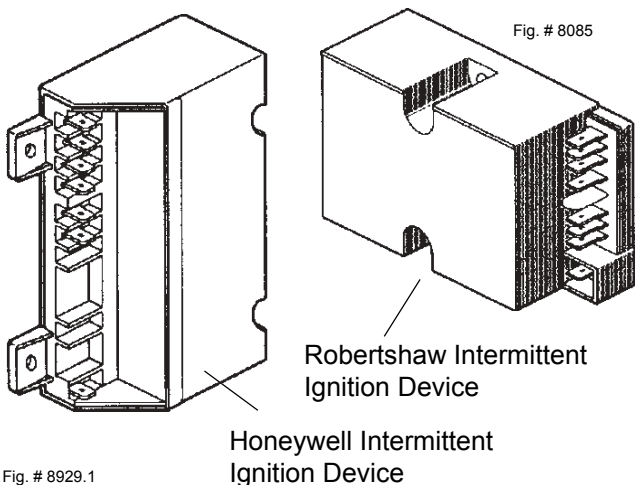

120V WIRING

For 120 V input power to the unit, connect the black wire to the “L1” or hot leg of the power supply. Connect the white wire to the “L2” or neutral leg of the power supply. Attach the wire nut to the red wire. There should be no connection to the red wire for 120V operation.

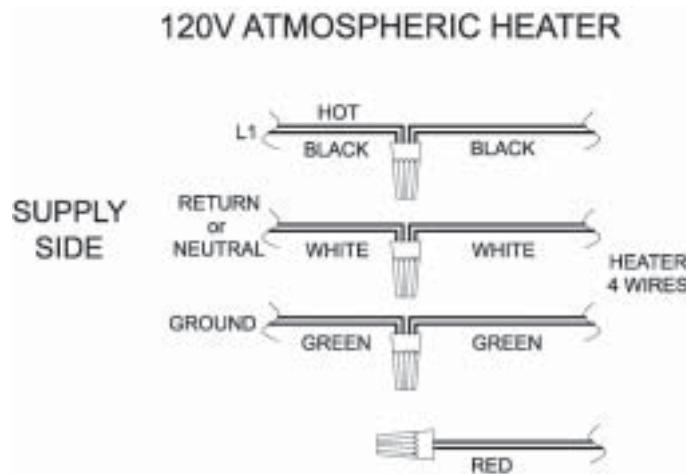

Fig. #9471

240V WIRING

For 240 V input power to the unit, connect the black wire to the “L1” or hot leg of the power supply. Connect the red wire to the “L2” or second hot leg of the power supply. Attach the wire nut to the white wire. There should be no connection to the white wire for 240V operation.

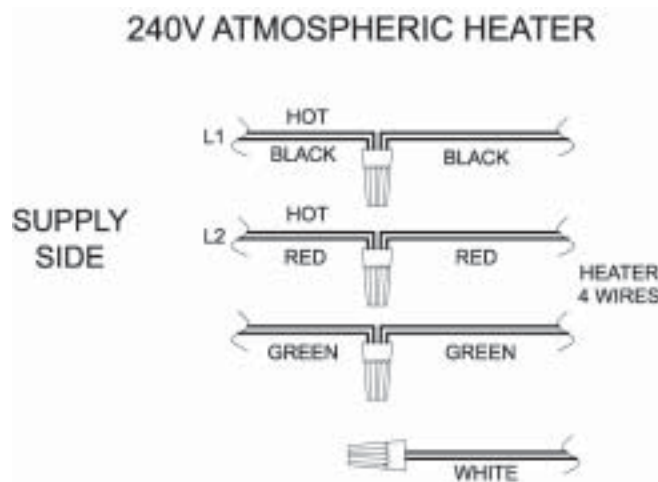
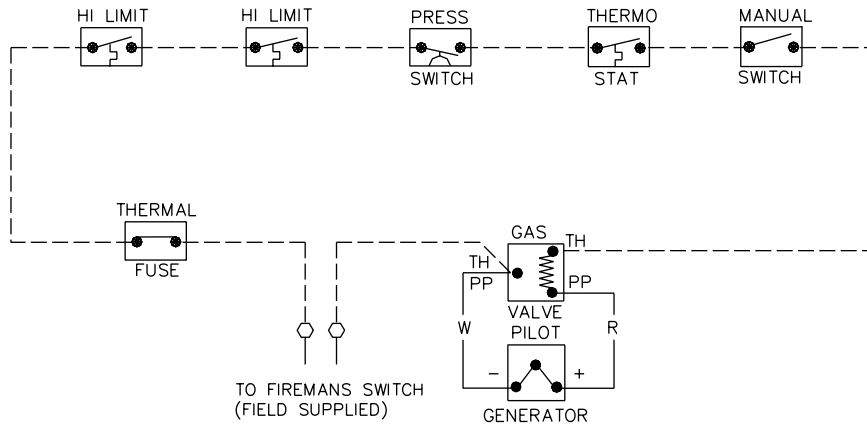

Fig. #9471.1

Heater must be electrically grounded and bonded in accordance with local codes, or, in the absence of local codes, with the latest edition of the National Electrical code, ANSI/NFPA 70. (Canada- Canadian Electrical Code, CSA C22.1, Part 1 and Part 2.)

NOTE: Input power to the heater (120/240V) can be supplied from the load (pump) side of time clock or directly from the switch/GFCI power source. It is preferred to make connection to the load/pump side of the time clock. When using the switched GFCI power source the heater could display false service indicators on the delay panel if the pump is turned off.

WIRING DIAGRAM - MILLIVOLT UNITS



ALL WIRING IS BLACK

150°C WIRE

Fig. #9266

WIRING DIAGRAM KEY

PINK CONNECTOR BLUE CONNECTOR

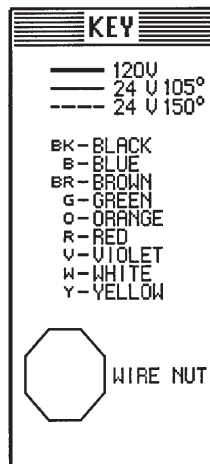

Fig. #8096

WIRING DIAGRAM - IID UNITS
HONEYWELL IGNITION DEVICE

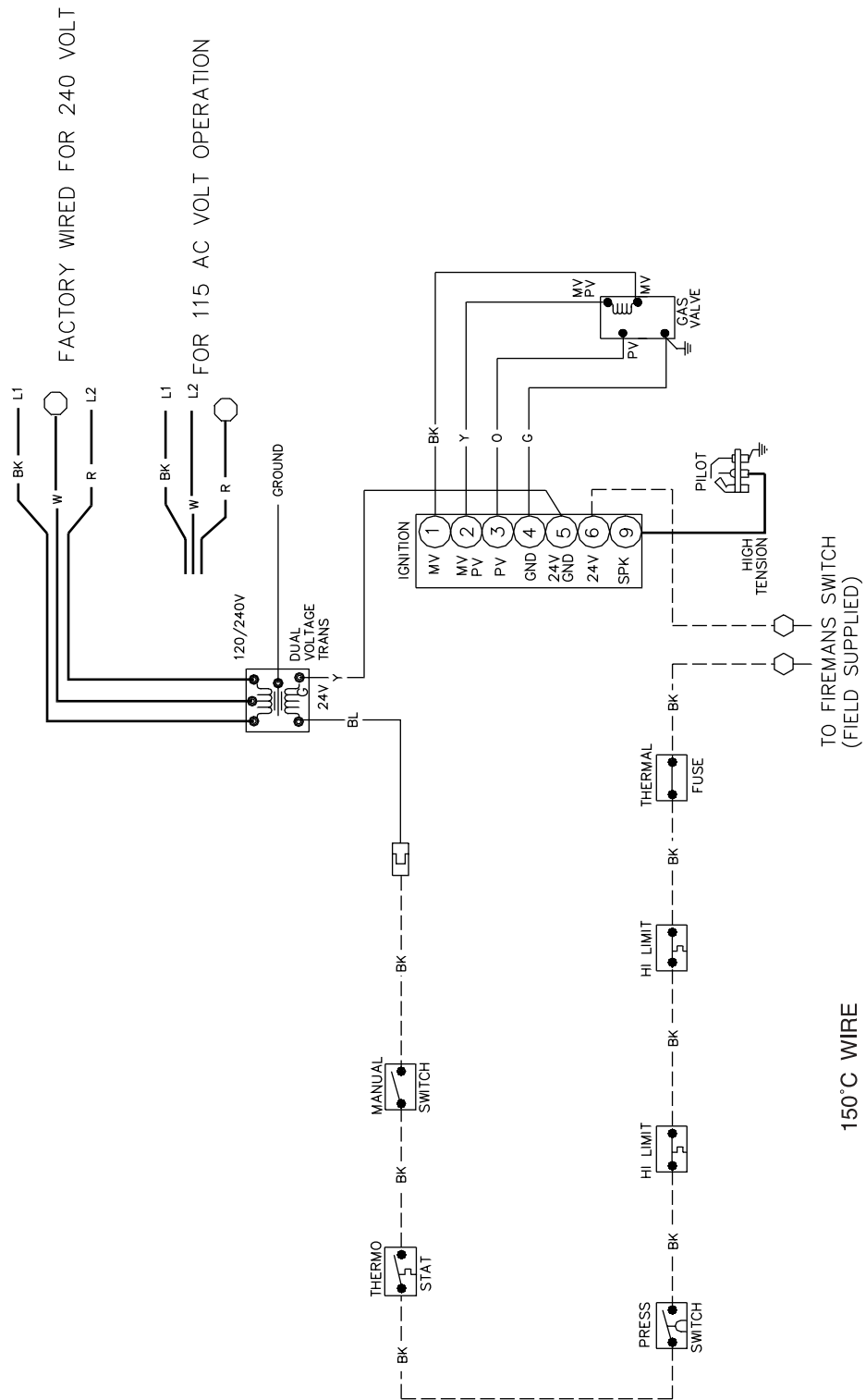

Fig. #9250

WIRING DIAGRAM - IID UNITS
ROBERTSHAW IGNITION DEVICE

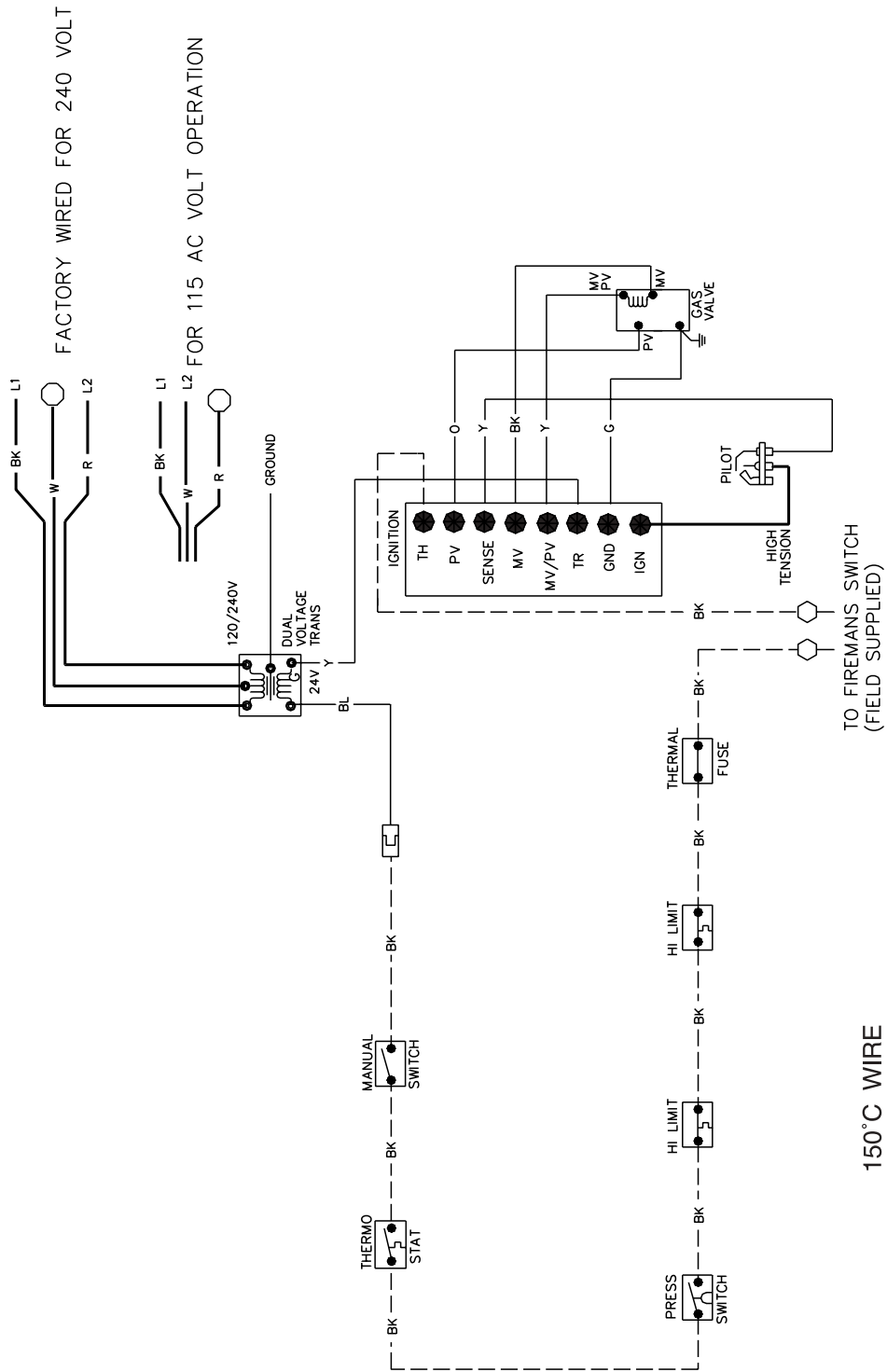
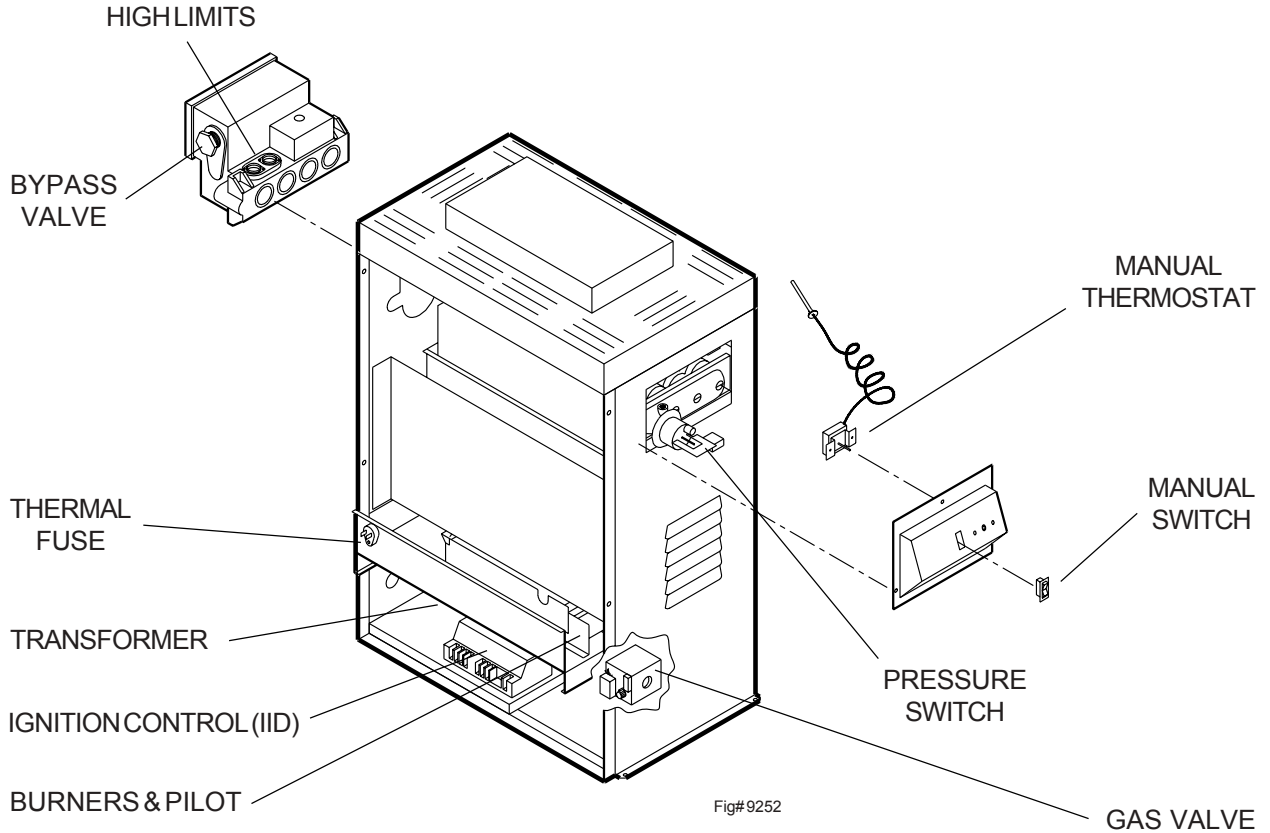

Fig. #9251

SECTION 4 / SERVICING INSTRUCTIONS

GENERAL LOCATION OF CONTROLS



THERMOSTAT ADJUSTMENTS/ REPLACEMENTS

The water temperature is controlled by a thermostat on the upper front panel of the heater, next to the On/Off toggle switch.

The thermostat is fitted with a means of limiting the upper temperature setting below the maximum limit. The knob stop ring illustrated below is adjustable by loosening the set screw, rotating the knob stop ring to the desired location and retightening the set screw.

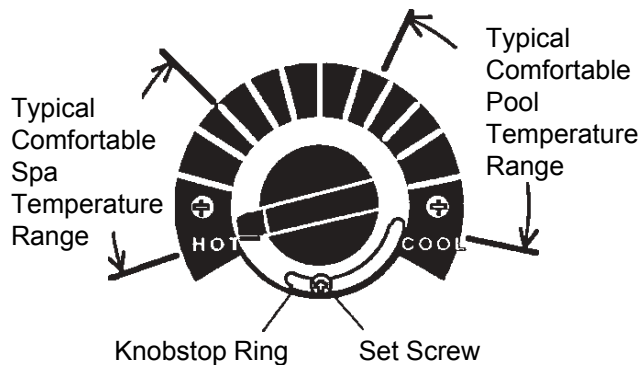

PRESSURE SWITCH

The pressure switch, or heater actuator, insures that the heater operates only when the filter pump is in operation. It is factory set at 1.75 PSI for deck-level installations. When the heater is located below the level of the spa or pool, it may be necessary to reset the pressure switch to compensate for the no-flow static head.

PRESSURE SWITCH ADJUSTMENT:

If it is necessary to reset the pressure switch, we recommend the following procedure:

1. With pump and heater on, turn adjustment knob (clockwise) until a click is heard from the gas valve.
2. Turn adjustment knob (counter-clockwise) 1/4 turn.
3. Turn pump off and on several times. Heater should shut-off immediately. If it does not, repeat steps above until proper adjustment is made.

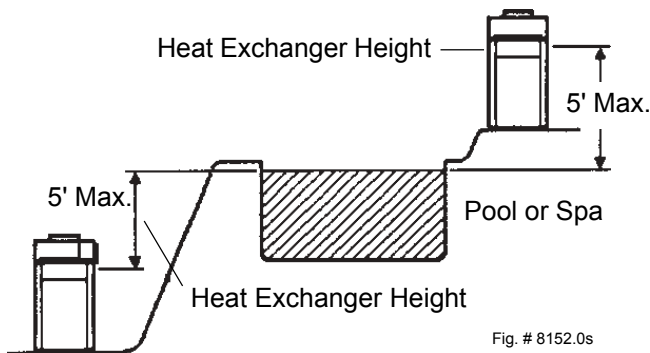
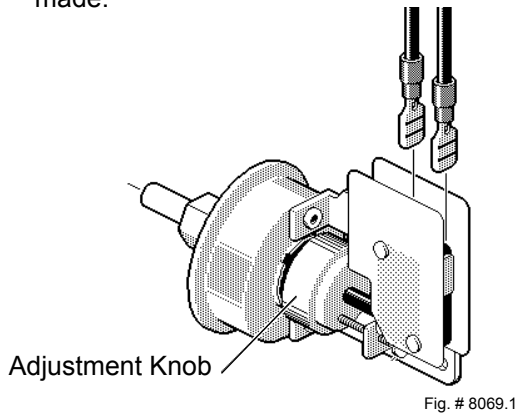

NOTE: If heater is installed outside of the limits shown, a flow switch must be used in place of the pressure switch when mounted and wired adjacent to the heater.

TWO-SPEED PUMPS

In some cases, the flow on the low speed is insufficient to operate the heater. This is apparent when the pressure switch cannot be further adjusted or if the heater makes banging noises. In these cases, the pump must be run at high speed when heating the water.

CAUTION: Do not operate the heater without the function of a properly adjusted pressure switch.

HIGH LIMITS

The heater is equipped with two automatic high limits. Both are set to open at 135°F.

NOTE: An erratic high limit is often characteristic of internal heat exchanger problem, such as scale build-up. Refer to troubleshooting section.



Fig. #2009

HIGH LIMIT REMOVAL

1. Shut-off main electrical power switch to heater.
2. Remove inspection panel.
3. Remove defective high limit and replace with a new high limit.
4. Replace inspection panel.

PILOT SAFETY

MILLIVOLT SYSTEM

The heaters equipped with the standing pilot (millivolt system), have pilot generators which act as a safety device to shut-off the flow of gas to the main burners and the pilot burner in case the pilot flame is extinguished. The pilot burner must be manually relighted to place the heater in operation again. Refer to the lighting instructions provided on the heater label.

IID UNITS (Electric Ignition)

The heater employs a pilot safety which closes the main gas valve within 8/10ths of a second whenever the pilot flame is interrupted. Pilot flame is automatically lit when the device is powered. Unit performs its own safety check and opens the main valve only after the pilot is proven to be lit.

BURNER TRAY REMOVAL

1. Shut-off main electrical power.
2. Shut-off gas upstream of heater.
3. Remove front door.
4. Disconnect gas line from gas valve.
5. Remove (2) screws that mount burner tray to unit.
6. Disconnect wires that terminate at gas valve.
7. Slide out burner tray.
8. Reverse above procedure to reinstall.

GAS VALVE REMOVAL

1. Remove burner tray. (See Burner Tray Removal procedure).
2. Disconnect pilot tubing from gas valve.
3. Remove gas valve with manifold from burner tray.
4. Remove manifold from gas valve.
5. Reverse above procedure to re-install.

MAIN BURNER AND ORIFICE REMOVAL

1. Remove burner tray. (See Burner Tray Removal procedure).
2. Remove screws and burner hold-down bracket.

NOTE: *If the heat exchanger is sooted badly, the burner hold-down bracket and spacer can become distorted from direct flame impingement and this usually necessitates replacement of these parts.*

3. Lift burners from slotted spacers and slide from orifices. Clean with a wire brush.
4. Orifices usually do not need to be replaced. To clean, run either copper wire or wood toothpick through orifice. Do not enlarge hole. To remove orifice, use a socket wrench and remove from manifold. DO NOT overtighten when reinstalling.

PILOT REMOVAL AND CLEANING

1. Remove burner tray. (See burner tray re-moval procedure).
2. Disconnect pilot tubing, disconnect wires from gas valve.
3. Disconnect pilot bracket from burner shield.
4. Remove pilot from bracket.
5. Remove pilot orifice and air opening (Honeywell MV unit only), and clean with wire or small brush.
CAUTION! DO NOT enlarge hole in pilot orifice.
6. Reverse above procedure to re-install.

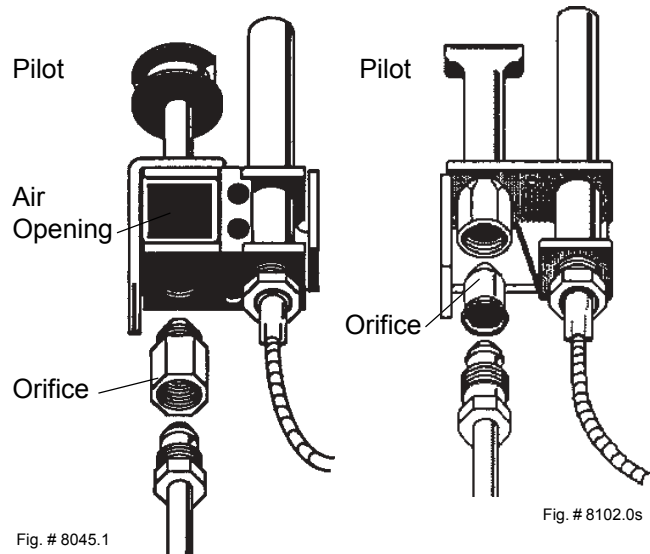

HONEYWELL PILOT

ROBERTSHAW PILOT

HEAT EXCHANGER REMOVAL

1. Shut water, gas, and electricity off, close valves and relieve pressure.
2. Drain heat exchanger.
3. Loosen and remove flange bolts.
4. Remove flange and inlet/outlet pipes from the header.
5. Remove outdoor stackless top or indoor stack top from unit.
6. Remove jacket top, flue collector, and baffles.
7. Remove upper front jacket panel, and disconnect wires at toggle switch.
8. Remove capillary bulb from inlet/outlet header.
9. Disconnect press switch tube from return header.
10. Disconnect hi-limit wire from thermostat, and pressure switch.
11. Lift heat exchanger straight up from combustion chamber, using caution not to damage refractory.
12. Reverse above procedure to re-install.

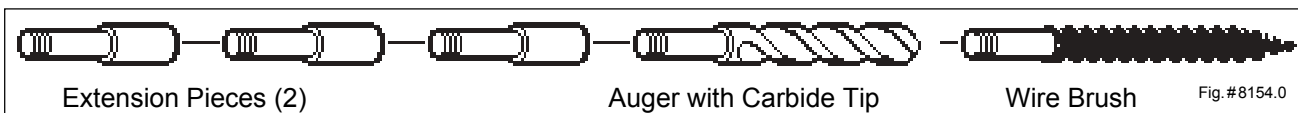

TUBE CLEANING PROCEDURE

Establish a regular inspection schedule, the frequency of which is dependant on local water conditions and the severity of service. Do not let the tubes clog up solidly. Clean out deposits over 1/16" in thickness.

The heater may be cleaned from the return header side, without breaking pipe connections. It is preferable, however, to remove both headers for better visibility through the tubes and to be sure the ground-up lime dust does not get into the system.

Note that you do not remove the top panel or the heat exchanger, generally.

After reaming, mount the wire brush in place of the auger and clean out debris remaining in the tubes.

Another method is to remove the heat exchanger, ream tubes and immerse heat exchanger in non-inhibited de-scale solvent for severe scale build-up.

TUBE REPLACEMENT PROCEDURE

Tube replacement may be effected without rolling, as a temporary means of repair, provided there are two or more tubes rolled in to act as stays on the left and right sides. The "O" rings should provide a seal up to 125 PSI working pressure. Use 3/8" heavy duty reversible drill motor or larger to power the tube roller. If a reversible drill is not available, after rolling the tube in, remove the drill motor and wrench out the roller. A tube roller is available from the factory.

Shut-off gas and power to the unit, close the system off and drain the heater. Remove the draft diverter. Remove the access panel and jacket top. Lift flue collector off. Remove "V" baffles over tube(s) to be replaced. If no pipe unions have been provided, use the header as a union, remove the flange nuts off the in/out header, break gas connection and slide heater away from piping to allow room to work. Pull wedge clips out of control wells and remove sensing bulbs. Remove flange nuts of the return header and remove header. Lift heat exchanger straight up and inspect "O" ring seals at this time. Unless severed they are reusable. The tube may be cut out with a hacksaw or hammer and chisel adjacent to both tube sheets, leaving studs in the tube sheets. Then proceed to collapse studs in the tube sheets with a chisel or screwdriver. Use caution not to cut into the tube sheet. Replacement tubes will have the fins stripped off longer on one end. The long end is inserted into the opening of the tube sheet first; then the short end is fitted through the opposite tube sheet. If the tube ends become dented or bent, straighten at least (4) inches back from the tube by means of a tapered punch.

Insert tube roller into tube opening up to stop against tube, then push center rod in until roller is tight. Be careful

to keep replacement tube squared up 1/8" outside each tube sheet. A loose tube will sometimes pull toward the roller. Attach drill motor to tube roller, holding it straight and level. Proceed to expand tube until the tool begins to grab. At this point, 1/2" to 1" should be exposed on the tool shank. Reverse drill motor or wrench out by hand. Care should be exercised to avoid applying excessive torque during rolling operation and to avoid thinning out any part of the tube wall excessively (over .015"). Use same procedure at the opposite end of the tube.

Apply line pressure test, and re-roll, if necessary before re-assembly of the heater.

DESOOTING PROCEDURE

CAUTION: SOOT IS COMBUSTIBLE. EXERCISE EXTREME CARE. NEVER USE A WIRE BRUSH.

Soot can clog areas between fins and cause eventual tube failure. Any sign of soot at the base of the burners or around the outer jacket indicates a need for cleaning.

1. Disconnect top portion of unit. (See Heat Exchanger Removal procedure, steps 1 through 6).
2. Remove burner tray (See Burner Tray Removal procedure.)
3. Take a garden hose and wash heat exchanger, making sure soot is removed completely from between fins. Avoid excessive water against refractory.

NOTE: *In extreme cases, it may be necessary to remove the heat exchanger completely for cleaning. The simplest method is steam cleaning at the local car wash. DO NOT WIRE BRUSH.*

COMBUSTION CHAMBER REMOVAL

1. Remove heat exchanger (See Heat Exchanger Removal procedure).
2. Lift up and remove front and rear refractory shield.
3. Remove refractory panels.
4. Reverse above procedure to re-install.



Refractory Panel Top View

Fig. # 8155.0s

SECTION 5 / TROUBLESHOOTING GUIDE

IMPORTANT NOTICE

These instructions are primarily intended for the use of qualified personnel specifically trained and experienced in the installation of this type of heating equipment and related system components. Installation and service personnel may be required by some states to be licensed. Persons not qualified shall not attempt to install this equipment nor attempt repairs according to these instructions.

MECHANICAL (FOR QUALIFIED SERVICE PERSONNEL ONLY)

<u>PROBLEM</u>	<u>CAUSE</u>	<u>SOLUTION</u>
Harmonics, or whining noise	*Debris or restriction in system.....	Locate the restriction and remove. Flush system and clean.
	*Debris in gas line.....	Remove debris or blow out gas line.
	Low flow due to scale formation in heat exchanger.....	Clean heat exchanger and check pool pH and total alkalinity.
Heater goes on and off continuously	Dirty filter.....	Backwash filter.
	Low water level in pool.....	Raise water level.
	External bypass setting out of adjustment.....	Adjust bypass.
	*Pressure switch out of adjustment.....	Adjust pressure switch.
Liming or scale forming on heat exchanger	Pool water chemistry.....	See Water Chemistry on page 2.
Sooting	High flow rates.....	Reduce by adding manual bypass valve and adjust by putting thermometer in header (1/4" NPT) drain opening. Set bypass so thermometer reads between 105° and 110°F.
	*Airstarvation.....	Refer to installation instructions.
	*Improper venting.....	Follow recommended installation instructions.
	*Insects or debris clogging burner intake ports.....	Clean burners.
Pilot outage	Low gas pressure.....	Adjust gas pressure.
	Restricted pilot.....	Clean pilot.
	Weak pilot generator.....	Replace pilot.
Yellow lazy flame	Low gas pressure.....	Adjust gas pressure.
	*Insects or debris clogging burner intake ports.....	Clean burners.
Outer jacket very hot (paint blistered)	*Broken refractory caused by shipping damage or improper combustion.....	Replace refractory panels.
Takes long time to heat pool or spa	Excessive sooting of heat exchanger.....	Determine cause of sooting & correct.
	Calculate undersized heater.....	Check heat rise per hour with the following formula: Heat rise (°/hr.)= $\frac{\text{Heater Output}}{\text{Pool Gallonage} \times 8.33}$
	Filter not running long enough.....	Reset time clock.
	Dirty filter.....	Clean filter.
	Gas line or meter undersized.....	Refer to installation instructions.

(* Usually occurs on initial start-up.)

Liming	LOWflow.....	Inspect bypass for movement, if no movement, replace.
Leaking at well	Overacid.....	Replace well and maintain proper water chemistry.
Leaking at heat exchanger	Overacid.....	Replace heat exchanger and maintain proper water chemistry.
Gasket brittle and leaking - (overheated)	Heater running after pump shuts off.....	See Pressure Switch Adjustment.
	Refractory damage.....	Replace refractory.
	Sooted heater.....	Determine cause of sooting and correct.

ELECTRICAL - MILLIVOLT

CAUTION: For qualified service personnel *only*.

1. Filter must be on with adequate water flow through heater.
2. Gas valve must be "ON" position. Thermostat set higher than pool water temperature.
3. Jumpers are for temporary check only. If left in place, they could cause the heater to burn up.

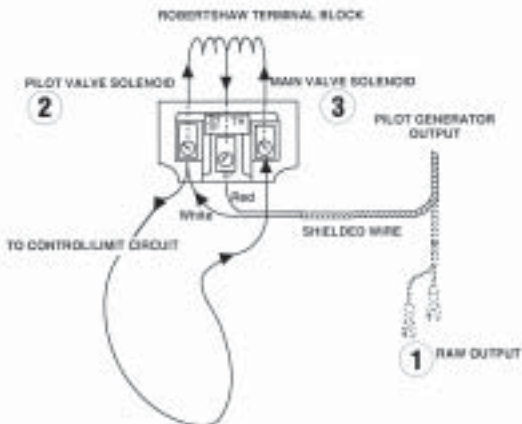
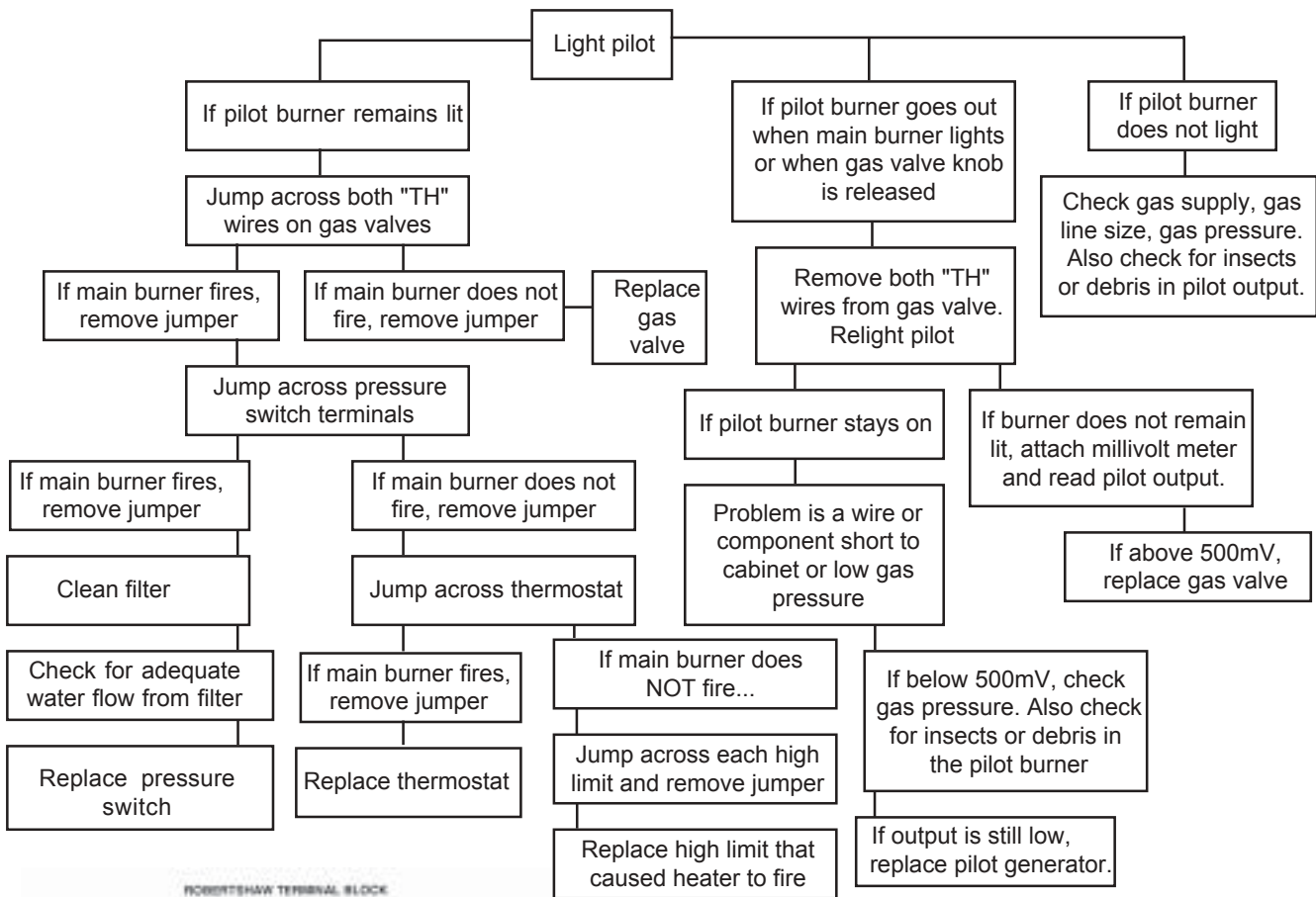

- 1 Raw Output (700mV± 100)**
 Pilot generator disconnected from valve (knob must be held down to keep pilot on).
 White – Negative
 Red + Positive
- 2 Pilot Load (500mV± 100)**
 Pilot generator connected to valve- Power applied to pilot solenoid.
 TP(Thermopile-Robertshaw)
 PP(Power Pile-Honeywell)
 TH TP – Common
 THPP – Common
- 3 Main Valve Load (200mV± 100)**
 Control/Limit circuit closed (All switches "ON").
 TP(Thermopile-Robertshaw)
 PP(Power Pile-Honeywell)
 TH TP – Common
 THPP – Common

ELECTRICAL - IID

WARNING
HIGH VOLTAGE
 For qualified technicians ONLY

NOTE: Some heaters may be equipped with an ignition module that shuts off pilot gas if pilot fails to light. To reset, interrupt power to heater.

Intermittent Pilot System TROUBLESHOOTING HONEYWELL S8600

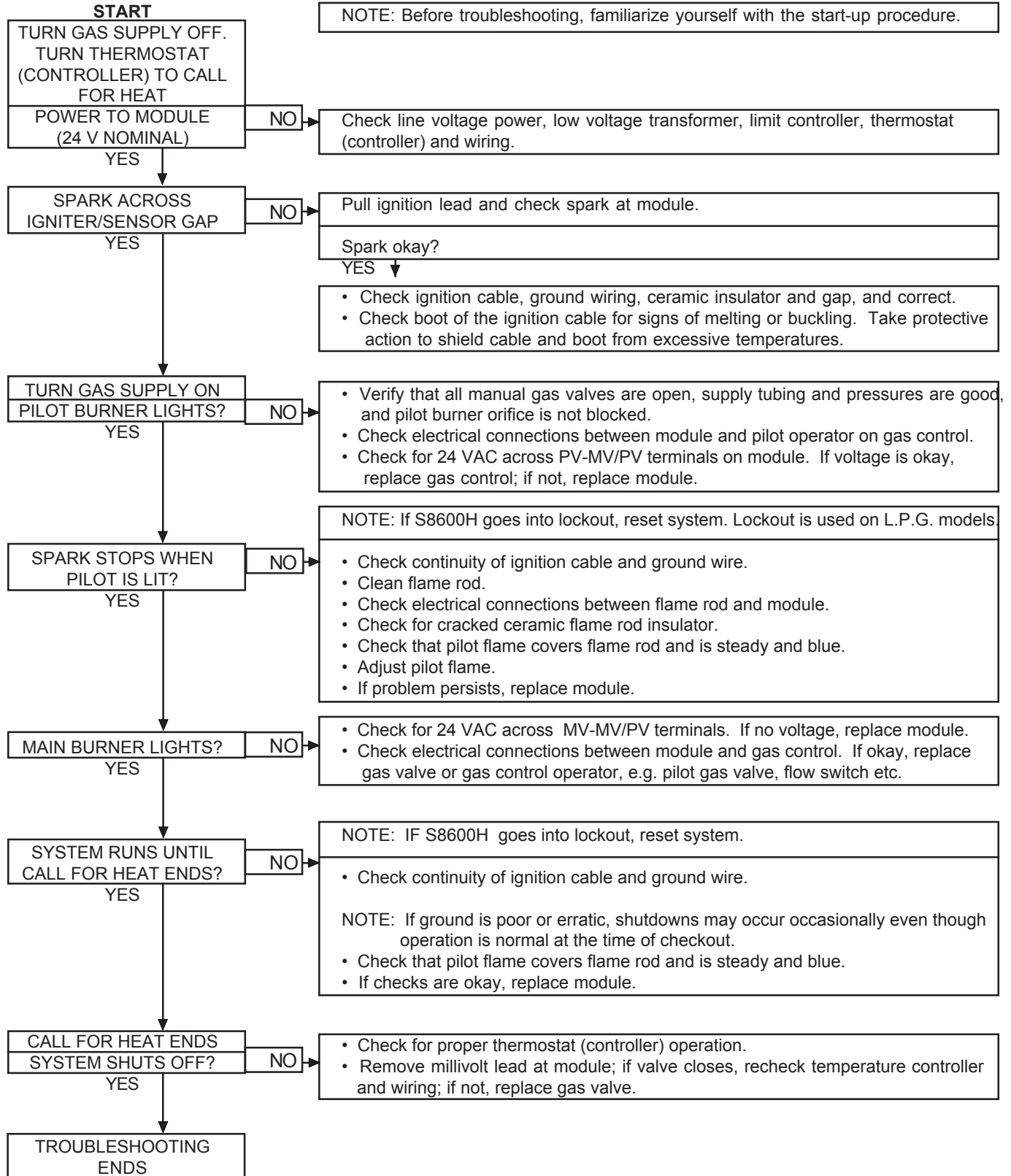

SECTION 6 / REPLACEMENT PARTS LIST

NOTE: *To supply the correct part it is important that you supply the model number, serial number and type of gas when applicable.*

Any part returned for replacement under standard company warranties must be properly tagged with a return parts tag, completely filled in with the heater serial number, model number, etc., and shipped to the manufacturer freight prepaid.

If determined defective by the manufacturer and within warranty, the part will be returned in kind or equal substitution, freight collect. Credit will not be issued.

Manufacturer:

2151 EASTMAN AVENUE
OXNARD, CA 93030

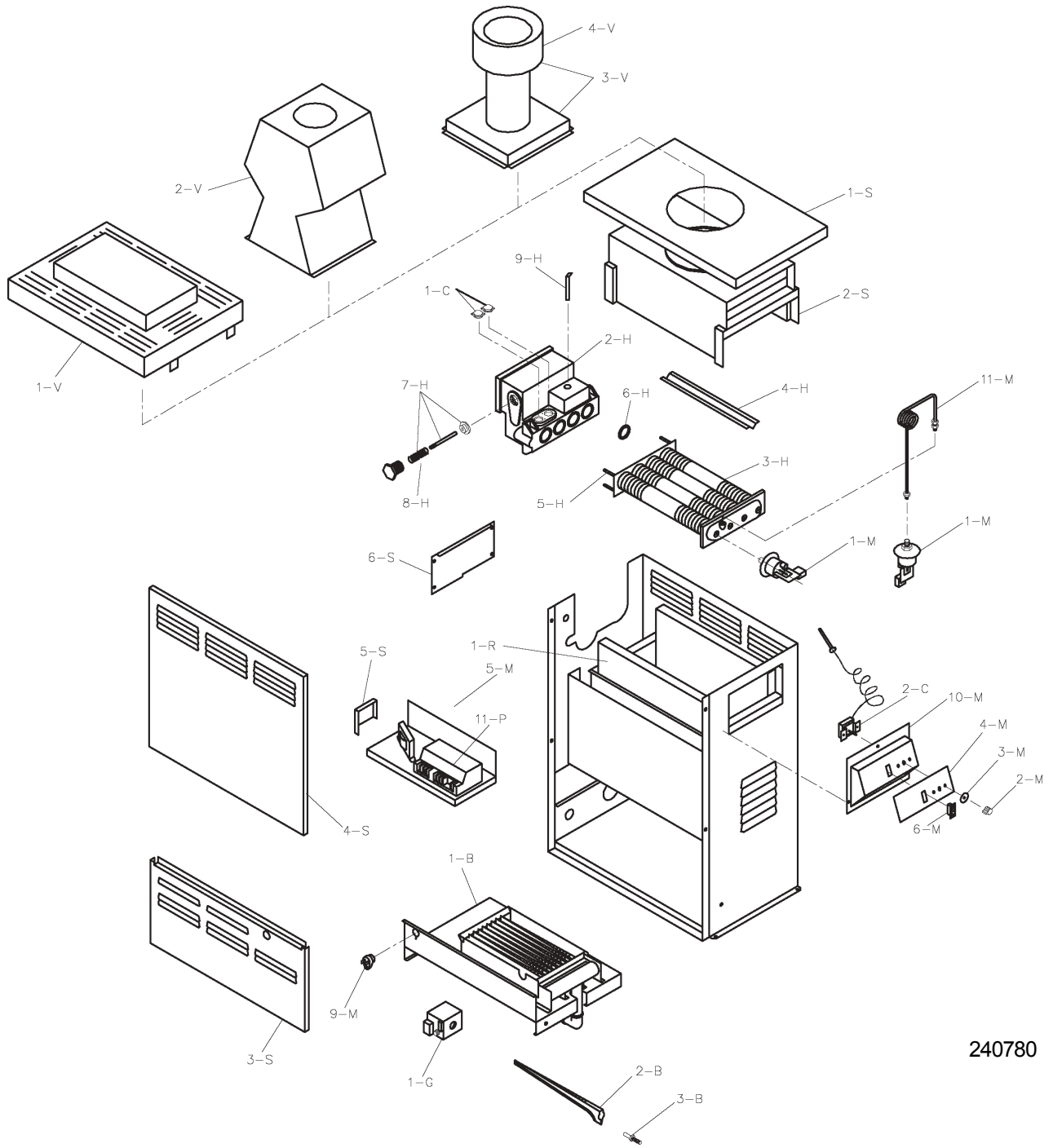

240780

MV

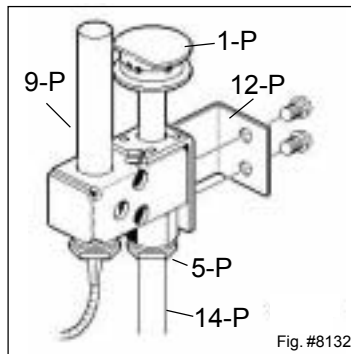

Fig. #8132

IID

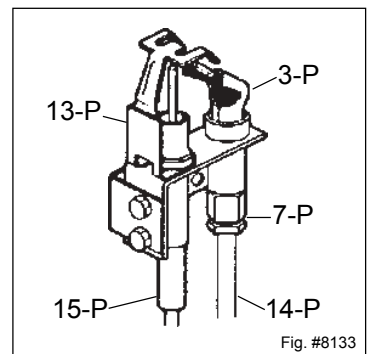

Fig. #8133

CALL OUT	DESCRIPTION	PART NUMBER
B	BURNER TRAY	
1-B	Burner Tray w/Burners (Sea Level)*	004899F
2-B	Burner	301210/8
3-B	Burner Orifice Nat. #51 (Sea Level)*	350080F/8
	Burner Orifice Pro. #59 (Sea Level)*	350350F/8
C	CONTROLS	
1-C	High Limit 135°F	006725F
2-C	Thermostat Control	003346F
G	GAS VALVE	
1-G	Combination Valve Nat. MV	003898F
	Combination Valve Pro. MV	003899F
	Combination Valve Nat. IID	003900F
	Combination Valve Pro. IID	004306F
H	HEAT EXCHANGER	
1-H	Heat Exchanger Assy. (Complete)	006888F
2-H	Inlet/Outlet Header	006887F
3-H	Tube Bundle	006889F
4-H	Baffle Kit	003964F
5-H	Carriage Bolt Kit	006890F
	Stud Bolt Kit	007957F
6-H	Header Gasket (4)	006891F
7-H	Bypass Valve	062235B
8-H	Bypass Spring	850252
9-H	Well Retaining Clip	300203
M	MISCELLANEOUS COMPONENTS	
1-M	Pressure Switch Direct Mount To Heater	006737F
	Pressure Switch Mount To Damper Tube	003651F
2-M	Thermostat Knob	006885F
3-M	Knob Stop	006886F
4-M	Dial Plate MV	006866F
	Dial Plate IID	006867F
5-M	Transformer (IID Unit)	006736F
6-M	Rocker Switch (SPST)	006872F
7-M	Wire Harness MV (Not Shown)	006873F
	Wire Harness IID (Not Shown)	006874F
8-M	Delimiting Kit (Not Shown)	052871F
9-M	Thermal Fuse	008126F
10-M	Bezel (Less Label)	006929F
11-M	Pressure Switch Tube Assy.	004904F

*For altitudes above 2,000 feet above sea level, consult the factory.

CALL OUT	DESCRIPTION	PART NUMBER
P	PILOT	
1-P	Pilot Nat. MV	600525B
	Pilot Pro. MV	600575B
3-P	Pilot Nat. IID	002003F
	Pilot Pro. IID	002003F
5-P	Pilot Orifice Nat. MV	003901F
	Pilot Orifice Pro. MV	003902F
7-P	Pilot Orifice Nat. IID	003903F
	Pilot Orifice Pro. IID	004308F
9-P	Pilot Generator MV	600019B
11-P	Ignition Control IID Nat.	004817B
	Ignition Control IID Pro.	004818B
12-P	Pilot Mounting Bracket MV	004907F
13-P	Pilot Mounting Bracket IID	004908F
	Pilot Tube	004078F
15-P	Hi Tension Wire IID	002654B
	Hi Tension Wire w/Pilot Electrode	007864F
R	REFRACTORY	
1-R	Refractory Block Kit	004909F
S	SHEETMETAL	
1-S	Jacket Top	006877F
2-S	Flue Collector	004911F
3-S	Door Assy.	004912F
4-S	Upper Jacket Control Panel	006881F
5-S	Wiring Box	306899
6-S	Access Panel (inlet / outlet end)	006883F
V	VENTING	
1-V	Stackless Top (Outdoor)	006930F
2-V	Drafthood (Indoor)	004897
3-V	Outdoor Stack w/Adapter (Outdoor)	004301
4-V	Outdoor Stack	951018
CONVERSION KITS**		
Nat. to Pro. MV Units		004915B
Pro. to Nat. MV Units		004916B
Nat. to Pro. IID Units		004917F
Pro. to Nat. IID Units		004918F

**** Gas Conversions are to be done only by a qualified agency.**