

**Raypak**<sup>®</sup>  
A Rheem<sup>®</sup> Company

# Protégé™ AGP

ABOVE GROUND POOL PUMPS

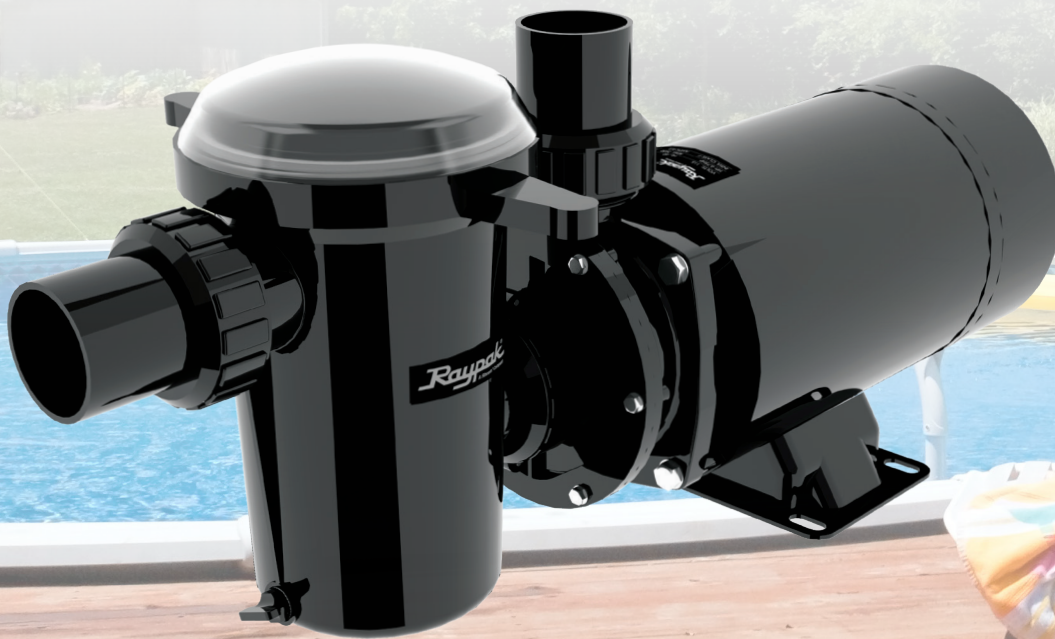

## Protégé™ Series

ABOVE GROUND POOL FILTERS & PUMPS



### TRANSPARENT COVER

Easily See When the Basket Needs Cleaning

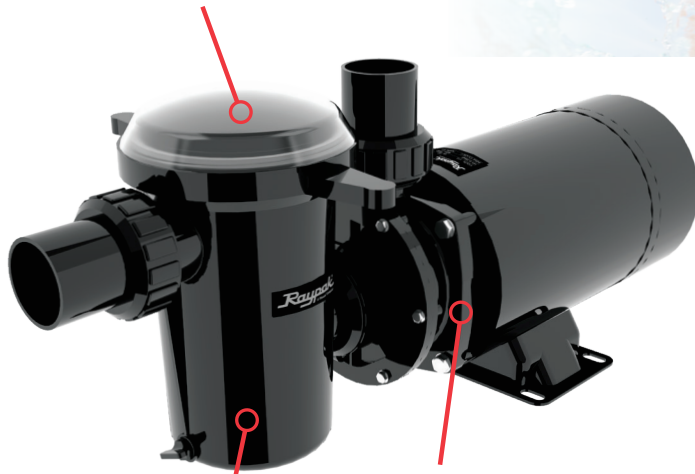

### DURABLE MOTOR

Long-Lasting,  
Quiet Operation

### LARGE STURDY BASKET

Longer  
Duration  
Between  
Cleanings



## About the Protégé AGP

The Protégé AGP is a reliable and durable high-performance above-ground pool pump, designed for efficiency and quiet operation. The Protégé AGP is designed with durable materials, safeguarding the pool pump from direct sunlight and hot water temperatures. It comes with a standard 1.5" suction and discharge port for continual filtration of your pool water.

The Protégé AGP is vital to your swimming pool's filtration system, ensuring steady and reliable flow to keep your pool clean and clear for enjoyment all year round.

## The Complete Package

All of our Protégé Series products pair perfectly with our Raypak pool heaters. No matter what setup or fuel type you need we have the right heating solution.

- Gas heaters up to 150 MBTUH
- Heat Pump heaters up to 61 MBTUH
- Electric heaters up to 92 MBTUH



## Complete your system with the Protégé Series.

The Protégé Series above ground pool pumps and filters keep your above ground pool clean and ready to enjoy. The series works perfectly in combination with our gas, heat pump and electric pool heaters. You can combine our Sand Filter (SF) with either the Above Ground Pump (AGP) or our Variable Speed Pump (VSP). For a complete ready to install system our Cartridge Filter Pump (CFP) or Sand Filter Pump (SFP) are the best choice.



### Boost Performance

Protégé products are the perfect companion to our pool heaters. Keeping your system clean and clear of debris helps the performance of your heater and contributes to the health and longevity of your above ground pool system.

### Build Your System

Our Protégé Series gives you the most options for building your ideal above ground pool system.

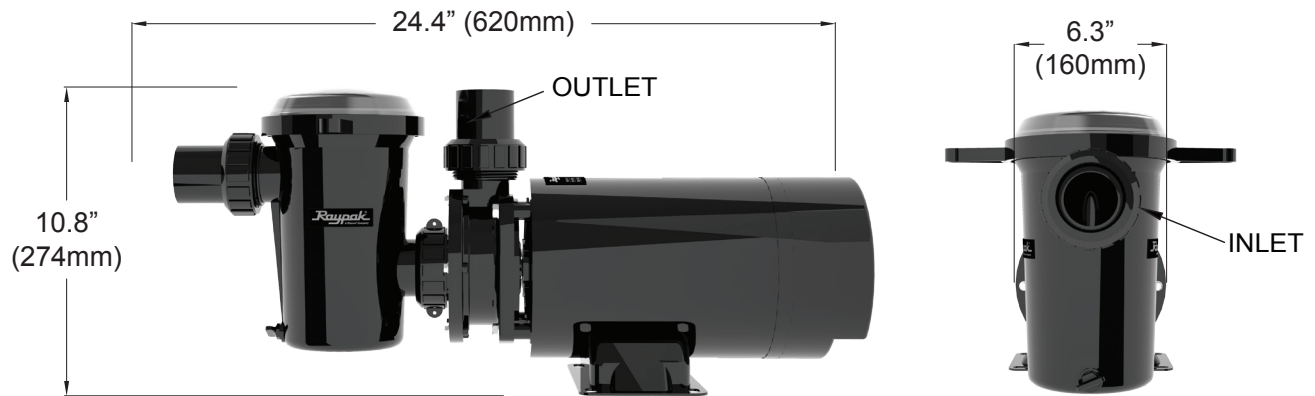

Model	Input Power	Power (HP)	Speed	Voltage	Connection Size
RPAGP75	0.55kW	0.75	Single	110/115V-60Hz	1.5"
RPAGP100	0.75kW	1.0	Single	110/115V-60Hz	1.5"
RPAGP102	0.75kW (Max)	1.0	Dual	110/115V-60Hz	1.5"
RPAGP150	1.1kW	1.5	Single	110/115V-60Hz	1.5"
RPAGP152	1.1kW (Max)	1.5	Dual	110/115V-60Hz	1.5"



## Indoor and Outdoor Weatherproof Materials

Protégé products are constructed with durable materials that stand up to normal weather conditions and can be installed indoor or outdoor.



## Easy to Maintain

Protégé products are designed to make cleaning easy, with large baskets on our pumps and a transparent lid that let's you check the level of trapped debris at a glance.

## Easy To Connect

Protégé products are quick and easy to install onto existing above ground pool pads or on new above ground pools. Save even more time and money when installing one of our filter/pump combination systems.

[www.raypak.com](http://www.raypak.com)

2151 Eastman Avenue | Oxnard, CA 93030 | 805-278-5300

Litho in U.S.A. ©2020 Raypak, Inc. 6000.09A Effective 08-01-20 Replaces 03-15-20