

# INSTALLATION & OPERATING INSTRUCTIONS

## Heat Pump Pool & Spa Heater



**Model Series**  
**5310, 6310, 6330HC & 8320**



**FOR YOUR SAFETY:** Do not store or use gasoline or other flammable vapors and liquids or other combustible materials in the vicinity of this or any other appliance. To do so may result in an explosion or fire.

**NOTE:** The instructions in this manual are for the use of qualified individuals specially trained and experienced in the installation and maintenance of this type of equipment and related system components. Installation and service personnel are required by some states to be licensed. Persons not qualified shall not attempt to install, service, or maintain this equipment.

This manual should be maintained in legible condition and kept adjacent to the heat pump pool heater or in a safe place for future use.

**Rev. 3** reflects the following: **Changes to:** The warning note at the top of the **Installation Considerations** section on page 6; the diagram on page 8; Table A and Table B on page 9, **The addition of:** A note to the bottom of Table B on page 9; the **Heat/Cool Operation (Model 6330HC Only)** section on page 12; wiring diagrams for model 6330HC on pages 23 and 24.

# Water Chemistry

(Corrosive water voids all warranties)

For your health and the protection of your pool equipment, it is essential that your water be chemically balanced. The following levels must be used as a guide for balanced water.

<b>Recommended Level(s)</b>	<b>Fiberglass Pools</b>	<b>Fiberglass Spas</b>	<b>Other Pool &amp; Spa Types</b>
Water Temp. (Deg. F)	68 to 88	89 to 104	68 to 104
pH	7.3 to 7.4	7.3 to 7.4	7.6 to 7.8
Total Alkalinity (PPM)	120 to 150	120 to 150	80 to 120
Calcium Hardness (PPM)	200 to 300	150 to 200	200 to 400
Salt (PPM)	<b>6000 MAXIMUM</b>	<b>6000 MAXIMUM</b>	<b>6000 MAXIMUM</b>
Free Chlorine (PPM)*	2 to 3	2 to 3	2 to 3
Total Dissolved Solids (PPM)	<b>3000 MAXIMUM</b>	<b>3000 MAXIMUM</b>	<b>3000 MAXIMUM</b>

**\*Free Chlorine MUST NOT EXCEED 5 PPM!**

- Occasional chemical shock dosing of the pool or spa water should not damage the heater providing the water is balanced.
- Automatic chemical dosing devices and salt chlorinators are usually more efficient in heated water. Unless controlled, they can lead to excessive chlorine level which can damage your heater.
- Further advice should be obtained from your pool or spa builder, accredited pool shop, or chemical supplier for the correct levels for your water.

---

# CONTENTS

<b>Water Chemistry</b>	<b>3</b>	<b>Troubleshooting</b>	<b>14</b>
<b>Warnings</b>	<b>5</b>	<b>Service Call Verification</b>	<b>15</b>
Pay Attention to These Terms	5	Power Supply	15
<b>Introduction</b>	<b>6</b>	Water Flow	15
<b>Installation Considerations</b>	<b>6</b>	Time Clock Adjustment	15
<b>Electrical Connections</b>	<b>7</b>	<b>Plumbing Diagrams</b>	<b>17</b>
<b>Water Connections</b>	<b>9</b>	<b>Wiring Diagram — 208V/230V</b>	
<b>Pressure Drop</b>	<b>9</b>	<b>Single-Phase — Analog Models</b>	<b>19</b>
<b>Controls &amp; Indicator Lamps</b>		<b>Wiring Diagram — 208V/230V</b>	
<b>(Analog Models)</b>	<b>10</b>	<b>Single-Phase — Digital Models</b>	<b>20</b>
<b>System Start-Up</b>	<b>11</b>	<b>Wiring Diagram — 208V/230V</b>	
<b>Controls (Digital Models)</b>	<b>11</b>	<b>3-Phase — Analog Models</b>	<b>21</b>
<b>Digital Controls Operating</b>		<b>Wiring Diagram — 208V/230V</b>	
<b>Instructions</b>	<b>12</b>	<b>3-Phase — Digital Models</b>	<b>22</b>
To Select Pool or Spa Mode	12	<b>Wiring Diagram — 208V/230V</b>	
To Increase the Desired Water		<b>Single-Phase — Model 6330HC</b>	<b>23</b>
Temperature (Pool or Spa Mode)	12	<b>Wiring Diagram — 208V/230V</b>	
To Lower Desired Water Temperature		<b>3-Phase — Model 6333HC</b>	<b>24</b>
(Pool or Spa Mode)	12	<b>Installing a Remote Control</b>	
To Select Temperature in °C or °F	12	<b>Device on Analog Heaters</b>	<b>25</b>
<b>Heat/Cool Operation</b>		Wiring	25
<b>(Model 6330HC Only)</b>	<b>12</b>	Heater Settings	25
<b>System Start-Up</b>	<b>13</b>	<b>Installing a Remote Control</b>	
<b>Seasonal Start-Up or</b>		<b>Device on Digital Heaters</b>	<b>25</b>
<b>Annual Check</b>	<b>13</b>	Wiring	25
<b>Summer Shutdown</b>	<b>13</b>	Heater Settings	25
<b>Freeze Protection</b>	<b>13</b>		
System Drain-Down	13		
Continuous Pump Operation	13		
<b>Maintenance</b>	<b>14</b>		
Air Coil Cleaning	14		
Cabinet Care (optional)	14		
Unplug Condensation Drain Holes	14		

---

## Warnings — Pay Attention to These Terms

<b>DANGER:</b>	Indicates the presence of immediate hazards which will cause severe personal injury, death or substantial property damage if ignored.
<b>WARNING:</b>	Indicates the presence of hazards or unsafe practices which could cause severe personal injury, death or substantial property damage if ignored.
<b>CAUTION:</b>	Indicates the presence of hazards or unsafe practices which could cause minor personal injury or product or property damage if ignored.
<b>NOTE:</b>	Indicates special instructions on installation, operation, or maintenance which are important but not related to personal injury hazards.

This manual, as well as the pool/spa heat pump pool heater itself, contains ANSI-approved product safety signs and labels. Please read these signs and labels, as they convey important safety information about hazards that may be potentially present in and around the heat pump pool heater.

**CAUTION:** Elevated water temperature can be hazardous. The U.S. Consumer Product Safety Commission has these guidelines:

1. Spa water temperatures should never exceed 104°F (40°C). A temperature of 100°F (38°C) is considered safe for a healthy adult. Special caution is suggested for young children.
2. Drinking of alcoholic beverages before or during spa or hot tub use can cause drowsiness which could lead to unconsciousness and subsequently result in drowning.
3. *Pregnant Women Beware!* Soaking in water over 102°F (39°C) can cause fetal damage during the first three months of pregnancy resulting in the birth of a brain-damaged or deformed child. Pregnant women should stick to the 100°F (38°C) maximum rule.
4. Before entering the spa or hot tub, users should check the water temperature with an accurate thermometer; spa or hot tub thermostats may err in regulating water temperatures by as much as 4°F (2.2°C).
5. Persons with a medical history of heart disease, circulatory problems, diabetes, or blood pressure problems should obtain a physician's advice before using pools or hot tubs.
6. Persons taking medications which induce drowsiness, such as tranquilizers, antihistamines, or anticoagulants, should not use spas or hot tubs.

**CAUTION:** Improper chemical content in a swimming pool or spa can damage the heat pump pool heater. DO NOT add pool chemicals to the skimmer. This will damage the heat pump pool heater and could void the heat pump pool heater warranty. ALWAYS follow the product manufacturer's directions when adding any chemicals to your pool.

---

## Introduction

**WARNING:** This pool/spa heat pump pool heater is an electromechanical machine that incorporates a pressurized refrigerant gas in a sealed system. ONLY trained and qualified service personnel are authorized to install or service this equipment. Without proper training and knowledge of such equipment, any attempt to install or service the unit could result in serious injury or even death.

This manual contains important information on the use, maintenance and troubleshooting of your new heat pump pool heater. This unit must be properly installed, maintained and operated for optimal performance.

This heat pump pool heater is an extremely efficient, economical machine designed specifically for swimming pool heating. It is similar in design and operation to a typical residential air conditioning system. The unit employs a hermetic motor/compressor operating in a refrigeration cycle to extract heat from ambient air and deliver it to the circulating pool water.

As with all heat pump pool heaters, compared to other types of heaters such as gas or oil-fired, this heat pump pool heater has lower heating capacity on a BTUH/hr basis. As a result, it will be required to operate longer to accomplish the desired results. It may, at certain times, operate as much as 24 hours per day. However, this should not be of concern to the owner, because the unit is designed to operate continuously. Even though it may operate continuously for many hours, it will still heat the pool with greater economy than other types of fossil fuel heaters.

Place a cover or blanket over the pool at night and other non-use periods. This will keep evaporation, the cause of main heat loss, to a minimum, and will greatly reduce pool heating costs. During warmer weather, the cover may be required only at night.

## Installation Considerations

**WARNING:** Do not install the unit within 3 ft of fossil fuel burning heaters. Air intake along the sides of this heat pump pool heater could disturb the combustion process of the unit, and could cause damage or personal injury.

- Mount the unit on a level, sturdy base, preferably a concrete slab or blocks. The size of the base should be at least 3 ft by 3 ft.
- You must install the 4 black rubber sound isolation pads (each 2 inches square) that ship with the unit. The pads are shipped in a bag with the unions, gaskets and the I&O manual. Install pads under the 4 corners of the unit to reduce vibration and sound transmission to the base.

**CAUTION:** The unit's supporting base must be high enough to keep it completely free of standing water at all times.

Situate the heat pump pool heater carefully to minimize installation costs while providing maximum efficiency of operation, and to allow adequate service access, as follows:

- For unrestricted air intake and service access, position each side of the unit at least 1 ft (30 cm) from walls, pipes and other obstructions.

**WARNING:** This unit is designed for outdoor installation; **DO NOT** install it in an enclosed area such as a shed or garage.

- Recirculation of cold discharge air back into the evaporator coil will greatly reduce the unit's heating capacity and efficiency.
- This unit features an 'up-flow' discharge for quiet operation. Air is pulled up through the evaporator coil and discharged through the top grill. Allow at least 5 ft (1.5 m) clearance above the unit for unrestricted air discharge. **DO NOT** install the unit under a porch or deck. Refer to Fig. 1.
- To minimize water piping, locate the unit as close as possible to the existing pool pump and filter.

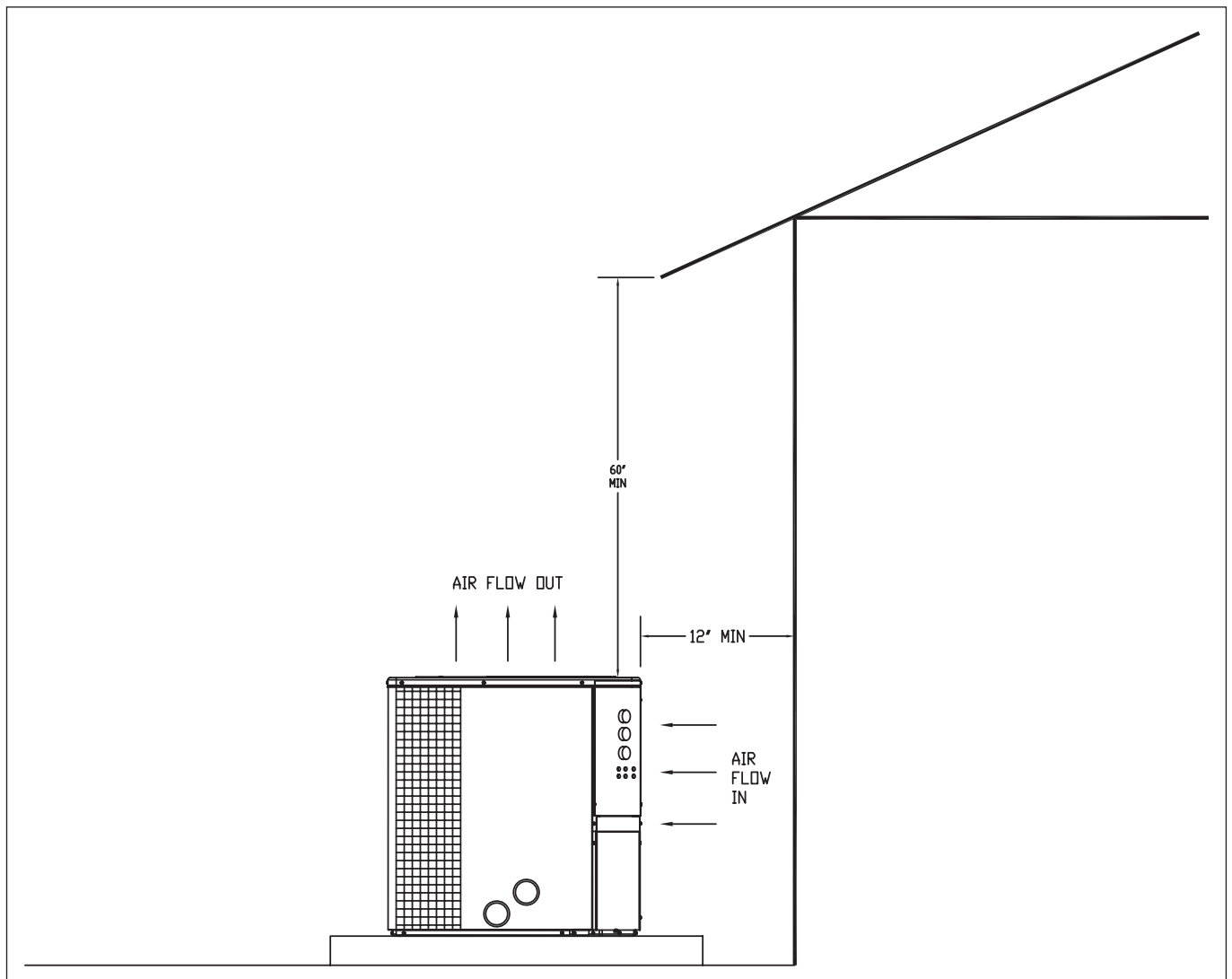

**Fig. 1: Installation Clearances**

- When installed in areas where freezing temperatures can be encountered, drain the water circuit to prevent possible freeze-up damage. See the Freeze Protection Section.
- For high wind installation requirements, refer to the diagram on page 8.

## Electrical Connections

Refer to the unit rating plate below the control panel for precise power requirements for your unit, and for ampacity and over-current protection requirements.

All wiring must be in accordance with the National Electrical Code, NFPA No. 70, latest edition, and all applicable state and local codes. Wiring diagrams are located on pages 19 through 24.

**NOTE:** Refer to the National Electrical Code, Article 680, for general requirements for swimming pools and equipment, and to Article 440 for special considerations necessary for circuits supplying hermetic refrigeration motor/compressors.

- Locate the equipment disconnect means within 3 feet of the heater's electrical enclosure, or as close to the heater as possible. Always satisfy applicable codes and standards.
- In sizing power wiring, be especially aware of up-sizing requirements necessary due to wiring distances. Always satisfy applicable codes and standards.
- Electrical installation should be done by a licensed electrician only.

FLORIDA BUILDING CODE 2001  
 WIND SPEED=150 MPH, 3 SEC GUST  
 EXPOSURE = C

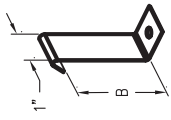

ANCHOR BRACKET DETAIL  
 (SEE BRACKET HURRICANE  
 TIE DOWN DWG #311874T)

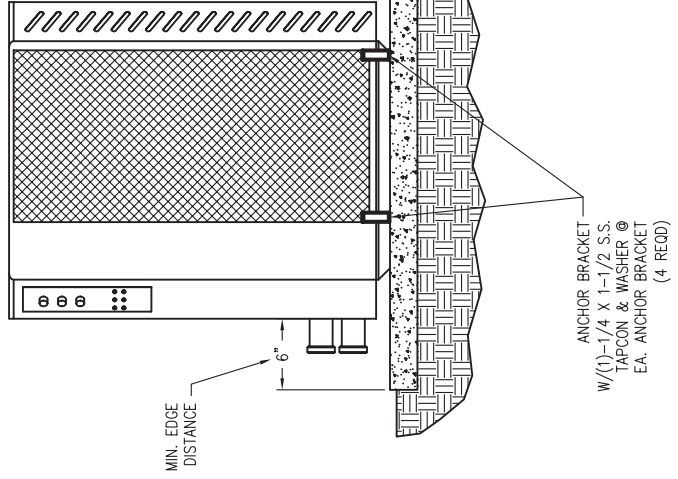
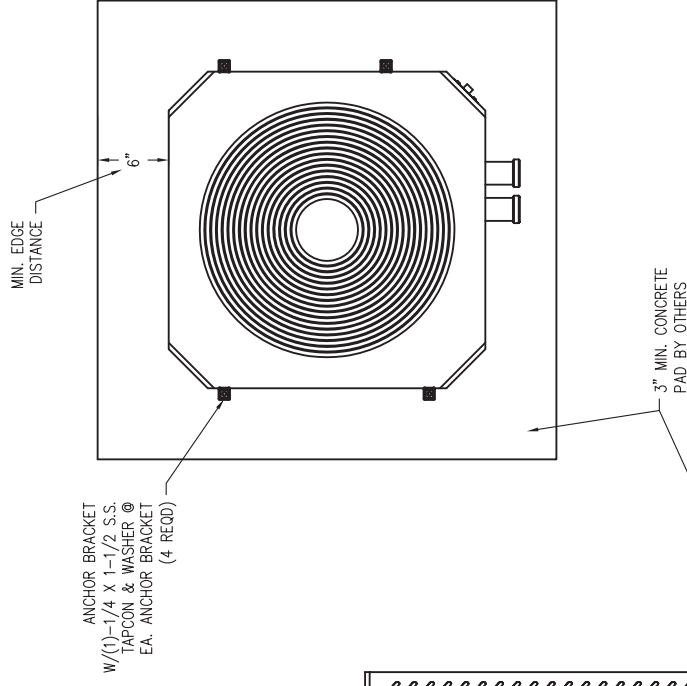
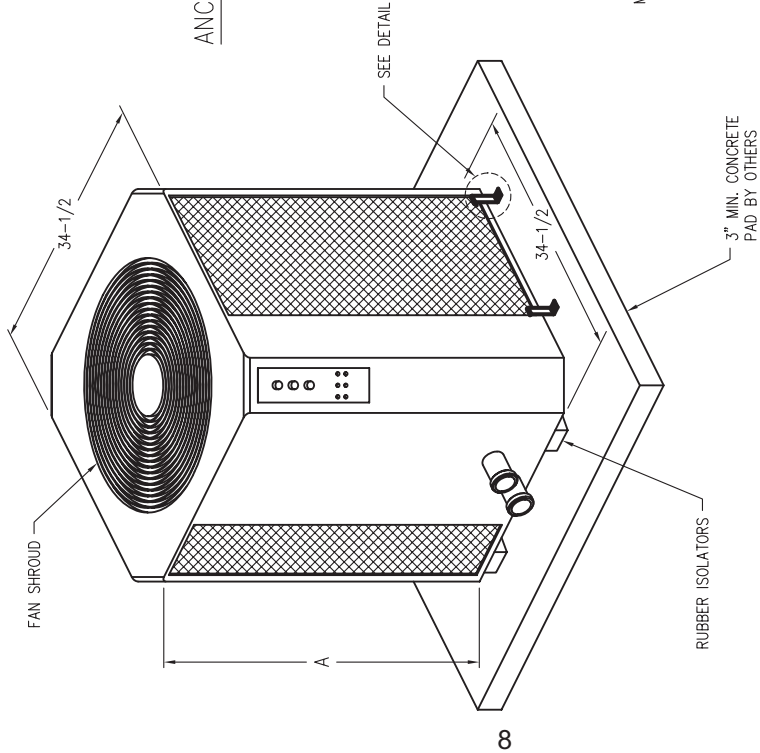

MODEL	A	B
5310	42-1/2	2.90
6310	42-1/2	2.90
6330HC	42-1/2	2.90
8220	38-1/2	6.30
8320	38-1/2	2.90



Model No.	VAC in - Phase - Hz	Minimum Circuit Ampacity (A)	Maximum Breaker Size (A)
5310	208/230 - 1 - 60	38.2	50
6310/6330HC	208/230 - 1 - 60	33.45	60
	208/230 - 3 - 60	25.45	50
8320	208/230 - 1 - 60	37.45	60
	208/230 - 3 - 60	33.3	60

Table A: Typical System Electrical Power Requirements

This unit is pre-wired to work with external control systems, heat-on-demand options and other external time clock overrides. Refer to the external control system's instructions, and page 22 of this manual, for installation information.

the purpose and, in either case, should be at least equal in size to the main pool/spa circulation piping.

## Water Connections

**CAUTION:** The heat pump pool heater inlet and outlet connections are **NOT** interchangeable. They must be connected as instructed below.

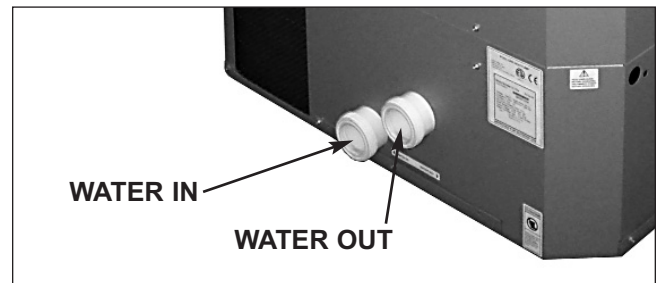

Fig. 2: Water Connections

1. Connect the heat pump pool heater in the return water line between the filter and the pool/spa. See the **Plumbing Diagrams** beginning on page 16.
2. Connect the filter outlet to the fitting marked **WATER IN** at the bottom front of the unit.
3. Connect the fitting marked **WATER OUT** to the return piping to the pool/spa. Unit inlet/outlet connection fittings are 2-inch PVC unions.
4. In cold weather (freeze zone) areas, shutoff valves (ball or gate type) must be installed at the unit inlet and outlet to facilitate service and cold weather drain-down.
5. Operate the pump and check the system for leaks.

## Pressure Drop

Water connections from the unit to the main return line can be PVC pipe or flexible pipe approved for

For system pressure drop information, refer to Table B below.

Flow (gpm)	Pressure Drop (psi)		
	5310	6310/6330HC	8320
30	4	6	9
40	7	9	9
50	10	10	10
60	11	11	11
70	12	12	12
80	13	13	13

Note: Multiply the pressure drop in psi by 2.3067 to yield the pressure drop in Ft. H<sub>2</sub>O Head (TDH).

Table B: Pressure Drop Across Heat Pump Pool Heater

**WARNING:** Install a check valve and/or a Hartford loop AFTER the heat pump pool heater and BEFORE any chlorinating devices. Install any automatic chemical feeders AFTER the heat pump pool heater. **Improper installation of any type of automatic chemical feeders can result in serious damage to, or premature failure of, the heat pump pool heater and will void the heat pump pool heater warranty.**

## Controls & Indicator Lamps (Analog Models)

Your analog heat pump pool heater incorporates safety controls and indicators to ensure its safe, reliable operation (for models with digital controls, see page 11).

**Water Pressure Switch:** Prevents operation when the pump is OFF. The unit requires 5 psi minimum pressure.

**Water Temperature Control:** Pool/spa water temperature is controlled by the heat pump pool heater thermostat on the unit control panel, which contains a switch and 2 thermostats, one for setting a heat spa temperature and the other for a swimming pool temperature. The switch can operate an optional external control system, or can switch between thermostats for pool or spa.

**NOTE:** The heat pump pool heater will not run when the **Remote** position is selected on the Pool/Spa selector switch and there is no remote control system attached.

**Defrost Switch:** Prevents heat pump pool heater operation if ambient air temperature falls below a pre-determined safe minimum (approximately 42° F).

**Delay Timer:** Prevents compressor from short cycling, which could damage or destroy the hermetic motor/compressor. Upon water temperature control satisfaction, or other circuit interruptions, this solid state device will prevent compressor restart for approximately 5 minutes.

**Refrigerant Low Pressure Control:** Stops the compressor if refrigerant suction (low side) pressure falls too low as a result of a malfunction, loss of charge or extreme cold conditions.

**Indicator Lamps:** There are 6 indicator lamps located on the unit control panel (see Fig. 3 below):

- **Power (amber lamp):** When lit, indicates power is applied to the unit.

**NOTE:** The heat pump pool heater will not run when the **Remote** position is selected on the Pool/Spa selector switch and there is no remote control system attached.

- **Water Flow (green lamp):** When lit, indicates normal water flow.
- **Heat Demand (green lamp):** When lit, indicates the actual water temperature is below the target water temperature.

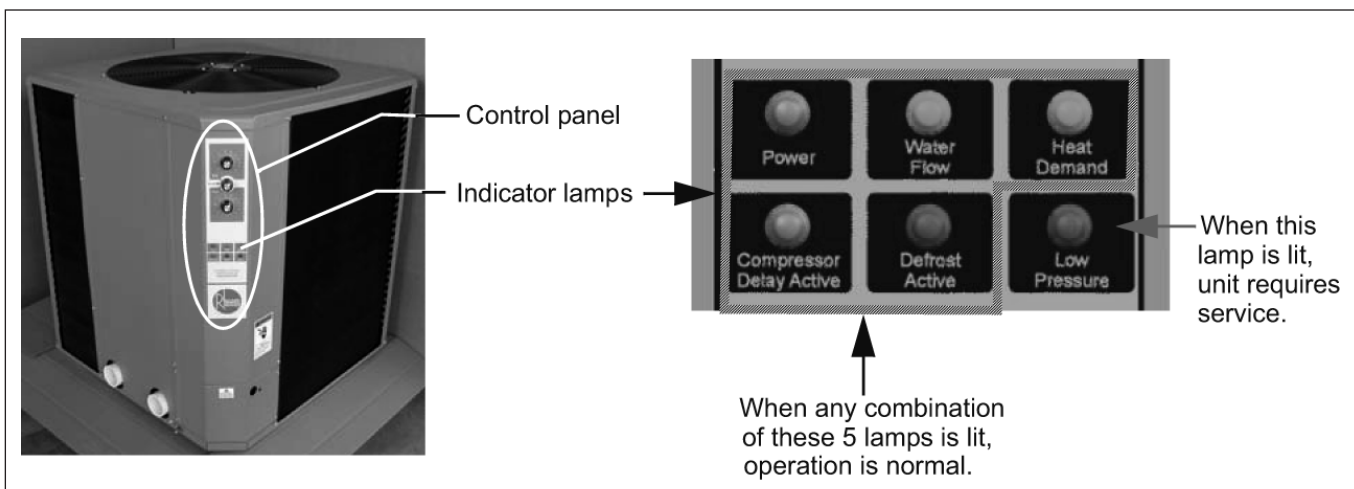

Fig. 3: Indicator Lamps — Analog Models

- **Compressor Delay Active (amber lamp):** Under normal operation, when lit, indicates compressor anti-short cycle timer is active. The fan will run but the compressor will be OFF for 6 to 8 minutes.
- **Defrost Active (red lamp):** When lit, indicates unit is in defrost mode. Defrost mode occurs when ice starts to form on the outside coil. The fan will continue to run but the compressor will stay OFF (not heating) until weather conditions improve.
- **Low Pressure (red lamp):** When lit, indicates failure in the refrigeration circuit. When this lamp is ON, service is required. Call for service assistance.

## System Start-Up

1. Verify that the **Power** lamp is ON and that the pool/spa pump is running and circulating properly.
2. Verify that the control panel **Spa-Remote-Pool** switch is in the **Remote** (OFF) position; see Fig. 4 below.
3. Turn the control switch to either **Pool** or **Spa** to turn the system ON and raise the thermostat setting above the current water temperature. At this time the 2 green lamps should illuminate. The fan and compressor should start up and run simultaneously.



Fig. 4: Selector Knobs — Analog Models

**NOTE:** The heat pump pool heater will not run when the **Remote** position is selected on the Pool/Spa selector switch and there is no remote control system attached.

4. Allow the heat pump pool heater to operate for a few minutes to stabilize operating pressures and to allow various component temperatures to normalize.
5. Verify that the discharge air temperature is approximately 8°–10° cooler than the air entering the unit. If not, see the Troubleshooting Section.

## Controls (Digital Models)

Your heat pump pool heater incorporates digital safety controls and indicators to ensure its safe, reliable operation (for models with analog controls, see page 10).

**Water Pressure Switch:** Prevents operation when the pump is OFF. The unit requires 5 psi minimum pressure.

**Digital Water Temperature Control:** The pool water temperature is controlled by the heat pump pool heater's digital control system, which gives you the option of two settings: one for the desired spa temperature and the other for the desired pool temperature. Additionally, as mentioned earlier, the unit is compatible with most '2-wire' and '3-wire' control/automation systems.



Fig. 5: Digital Water Temperature Control

**Defrost Sensor:** Prevents unit operation if ambient air temperature falls below a predetermined safe minimum (approximately 42°–48°F, based on humidity). The compressor will shut OFF but the fan will continue to run.

**Delay Timer:** Prevents compressor from short cycling, which could damage or destroy the hermetic motor/compressor. Upon water temperature control satisfaction, or other circuit interruptions, this solid state device will prevent compressor restart for approximately 5 minutes.

---

## Digital Controls Operating Instructions

The electronic board has the capability of memorizing two different programmed temperature settings as follows (refer to Fig. 5):

- For a pool, maximum 95°F (35°C)
- For a spa, maximum 104°F (40°C)

### To Select Pool or Spa Mode

To have access to either one of these programs, press the SET key until you see **P \_S** and by pressing the UP or DOWN key you can switch to **POL** or **SPA**.

### To Increase the Desired Water Temperature (Pool or Spa Mode)

Push the SET key until you see **POL** or **SPA**. The programmed temperature will be displayed. Press the UP arrow to increase the temperature setting one degree at a time.

### To Lower the Desired Water Temperature (Pool or Spa Mode)

Push the SET key until you see **POL** or **SPA**. The programmed temperature will be displayed. Press the DOWN arrow to decrease the temperature setting one degree at a time.

Once the control has been programmed to the desired pool water temperature, the programmed temperature will be displayed for approximately 5 seconds. Then the digital display will display the actual pool water temperature.

**To make the Board a Pool ONLY Board, call 800-375-7378 for instructions.**

### To Select Temperature in °C or °F

Press the SET key until you see **F \_C**. By pressing the UP or DOWN key you can switch to **°F** or **°C**. Once the temperature display mode has been programmed it will be displayed for approximately 5 seconds, then the digital display will return to the actual pool water temperature in the mode that you have chosen.

## Heat/Cool Operation (Model 6330HC Only)

The heat/cool model is designed to both heat and cool the pool. To select heat or cool mode, push the **SET** key until **H/C** is displayed. Press the **DOWN** arrow key to select heating (**hea**), or the **UP** arrow key to select cooling (**col**). Set the desired setpoint temperature as described earlier in this manual.

**NOTE:** Once the control has been programmed to the desired pool water temperature, the programmed temperature will be displayed for approximately 5 seconds. The digital display will then show the actual pool water temperature.

**NOTE:** Remove the pool/spa blanket and turn on any fountains, sprays or other water features to speed cooling.

When the unit has been operating in the heating mode for a few minutes, the discharge air temperature should be 8°–10°F cooler than the air entering the unit.

When the unit has been operating in the cooling mode for a few minutes, the discharge air temperature should be 8°–10°F warmer than the air entering the unit.

**NOTE:** Heating is more efficient during warmer daylight hours and cooling is more efficient during cooler night time hours.

---

## System Start-Up

1. Verify that the Digital Board is displaying a temperature and the pool pump is running and water is circulating properly.
2. Verify that the Board is programmed so that the desired temperature of the Pool and Spa is higher than the displayed current water temperature.
3. Allow the heat pump pool heater to operate for a few minutes to stabilize operating pressures and to allow various component temperatures to normalize.
4. Verify that the discharge air temperature is approximately 8°–10°F cooler than the air entering the unit. If not, see the Troubleshooting Section.

## Seasonal Start-Up or Annual Check

**NOTE:** At the beginning of the heating season, or whenever the pool water temperature is to be raised several degrees, the pool pump and heat pump pool heater may need to operate continuously for several days. During summer months, only a few hours per day may be necessary, or none at all.

1. Remove leaves, pine needles, etc., from the evaporator coil. Clean the coil by gently applying a mild solution of household liquid soap and water.
2. Gently rinse the coil with water; **DO NOT** use high pressure.
3. Backwash or otherwise clean the pool filter. If necessary, clean the skimmer basket and pump strainer.

**NOTE:** If the pool pump and heat pump pool heater shut OFF before the water temperature is raised to the desired level, you must lengthen the running time of both. To do this, reset the time clock dial for the longer running time, or manually operate the pump with the timer override switch. Since the heat pump pool heater capacity and efficiency are both greater at higher ambient air temperatures, run time should be set to take advantage of all daylight hours, when the air is generally warmer.

4. Set the valves to ensure proper water flow through the unit.

## Summer Shutdown

If you do not plan to use the heat pump pool heater during the summer months, secure and protect it as follows:

1. Turn the unit circuit breaker or disconnect switch to OFF.
2. Leave the valves set the way they are unless additional circulation is required. **DO NOT** stop all flow through the heat pump pool heater.
3. **IMPORTANT:** Remember to reset the valves before the next heating season, or the unit will not operate properly.

## Freeze Protection

If the unit is installed in a location subject to freezing conditions, it is important to protect the water circuit from freezing, just as should be done for the pump and filter.

## System Drain-Down

1. Turn the unit circuit breaker or disconnect switch to OFF.
2. With the pool pump OFF, close the external shut-off valves and loosen the inlet and outlet water unions to allow water to drain. Use a Wet/Dry Vac or air pressure to remove excess water.
3. Loosely re-attach the unions.
4. Cover the unit with a waterproof cover.

## Continuous Pump Operation

It is also possible in some areas to prevent unit freeze damage by operating the pump continuously during freezing weather. However, this results in significantly higher pump operating costs. Further, if a sustained power failure occurs, the unit **MUST** be drained anyway, or freeze damage could result.

---

## Maintenance

**NOTE:** The heat pump pool heater **MANUFACTURER IS NOT RESPONSIBLE** for maintenance adjustments.

The following maintenance procedures are designed to keep your unit operating at a high level of reliability. **Maintenance must be performed on a periodic basis to maintain warranty coverage** and prevent system failures and performance degradation.

### Air Coil Cleaning

Efficient operation depends on free circulation of air through the thin and tightly-spaced fins of the evaporator coil(s). The evaporator **must** be cleaned whenever it has a buildup of dirt or debris.

**CAUTION:** To clean the fins, spray gently with a garden hose. **DO NOT pressure wash.** Doing so will bend the fins and can void the warranty.

### Cabinet Care (optional)

The cabinet is designed for outdoor use and requires little care. However, you can clean it if you wish.

**WARNING:** Shut **OFF** electricity to the unit before cleaning.

Wash the cabinet with soap and water.

### Unplug Condensation Drain Holes

The unit extracts humidity from the air as it passes through the coil, similar to the way a cold drink outside “sweats” on a hot day. This condensation drains from the bottom of the unit.

1. Routinely check to be sure the condensation drain holes in the base of the unit are not plugged with dirt or debris.
2. If condensation becomes a problem, optional drain pans are available from your heat pump pool heater distributor or pool dealer.

## Troubleshooting

If your unit does not operate, or simply does not heat your pool water, Fault Codes (digital models), or the indicator lamps (analog models) on the front control panel, can provide valuable clues as to what is wrong, and may even indicate precisely what the problem is. Always observe these codes (or lamps) before calling a service representative. By reporting on the telephone the Fault Codes (or which lamps are ON or OFF) that are showing, the service rep may be able to solve the problem without the expense of a service call.

### A. UNIT IS RUNNING, BUT NOT HEATING

- Is water flow through the unit adequate? Check the unit for obstructions, such as a clogged filter pump strainer, a dirty filter, or valves not positioned correctly.
- Is the ejected air from the unit 8°–10°F cooler than incoming air? If so, the unit is extracting heat from the air and transferring it to the pool.
- Is water condensing on the evaporator and internal copper pipes? This is also evidence of heat removal from the air. When the air is cool with low humidity, condensation may not be evident.
- How long has the unit been operating? During initial pool heating in cold weather, it may require a week to elevate the water temperature to a comfortable level. Normally, it takes about 4 days.

How many hours per day is the unit operating? **Remember that the heat pump pool heater only operates while the pool pump is running.** Set the time clock to permit 24 hour per day operation. After the desired temperature is reached, return the unit to normal operation of 8–10 hours per day.

**NOTE:** If the pool pump and heat pump pool heater shut OFF before the water temperature is raised to the desired level, you must lengthen the running time of both. To do this, reset the time clock dial for the longer running time, or manually operate the pump with the timer override switch. Since the unit capacity and efficiency are both greater at higher ambient air temperatures, run time should be set to take advantage of all daylight hours, when the air is generally warmer.

- Is airflow through the unit being obstructed? Restrictions such as shrubbery, tall grass, dirty

coils, or any other obstruction to airflow will reduce performance.

- Is the pool blanket/cover being used? Unblanketed pools can lose up to 10 degrees per night compared to 4 degrees or fewer when a blanket is used. Without a blanket, the total heat gained during the day can be lost overnight.
- Are rapid heat losses occurring in some other way, such as high wind, spillage, rainfall, flow through solar panels at night, or a high water table?

## B. UNIT IS NOT RUNNING

- Is the temperature display or control panel **Power** lamp ON? If not, the circuit breaker may be shut OFF or tripped. Reset the breaker by switching it OFF, and then back ON. **Verify that the breaker is set and operating properly before calling for service.**
- Is the thermostat setting and the Pool/Spa setting correct? Verify that the temperature has been properly set on the thermostat, and that it is **higher** than the current water temperature. On analog units, all 3 lamps should be illuminated and the fan should begin to run.
- Have you waited approximately 5 minutes for the time delay? After the unit has been running and then shut OFF for any reason, there is a delay before operation can begin again.
- Is the **Heat Light** or **Heat Demand** lamp ON? If not, then the thermostat setting is not higher than the temperature of the water. Raise the thermostat setting.

**NOTE:** The heat pump pool heater will not run when the **Remote** position is selected on the Pool/Spa selector switch and there is no remote control system attached.

## C. CONDENSATION SEEMS EXCESSIVE

Heat pump pool heaters can produce a large amount of condensation (water) during operation. If you suspect that the unit is leaking:

- a. Use a pool chemistry test kit to confirm there is no chlorine in the condensation. **Or,**
- b. Shut the unit OFF and leave the filter pump running to see if the water stops dripping. If the water stops dripping, the unit is **not** leaking.

## Service Call Verification

Before you make a service call, **first** determine if the problem is:

- Warranty Service
- Unit operation (power supply, water flow, or time clock adjustment)

**NOTE:** The **MANUFACTURER IS NOT RESPONSIBLE** for these adjustments.

## Power Supply

- Verify that all circuit breakers are reset and working properly.
- If the temperature display or the **Power** lamp on the control panel still does not light, contact the installing dealer, since it may be a power problem requiring an electrician.

## Water Flow

- Verify that the pool filter is clean to provide good flow.
- Verify that valves are properly positioned to allow adequate water flow through the unit.
- If the **Water Flow** lamp (analog models) on the control panel still does not light, and water is circulating in the pool, verify that all valves are positioned correctly.

## Time Clock Adjustment

Verify that the time clock is set to permit the unit to run long enough to heat properly.

Fault Code	Meaning of Code
OFF	The desired programmed temperature point is lower than 60°F (15°C).
LP & LP3	Shortage of refrigerant gas in the unit or faulty low pressure control. The unit will show (LP3) after 3 LP faults and shuts down the unit and <b>pool pump</b> for protection. If this occurs, you should call for service.
HP & HP3	Low water flow in the unit or faulty high pressure control. Check water flow/backwash. The unit will show (HP3) after 3 HP faults. This will stop the unit for protection.
FLo & FL3	<p>Possible causes:</p> <ul style="list-style-type: none"> <li>• The filter is in backwash position.</li> <li>• The filter pump is stopped.</li> <li>• The filter is dirty.</li> <li>• Shortage of water to pool pump.</li> <li>• <b>FIL parameter must be set to activate pool pump.</b></li> <li>• Water pressure switch must be adjusted or it is broken.</li> <li>• The unit is in the protection mode and will show (FL3), press any key to restart the unit. FL3 code will stop the unit and <b>pool pump</b>.</li> </ul>
FS	Unit is in the defrosting cycle. (The fan works but the compressor is stopped.)
- -	Keypad is pressing down on both buttons. Replace keypad.

**Table C: Control Board Fault Codes — Digital Models**



## Plumbing Diagrams

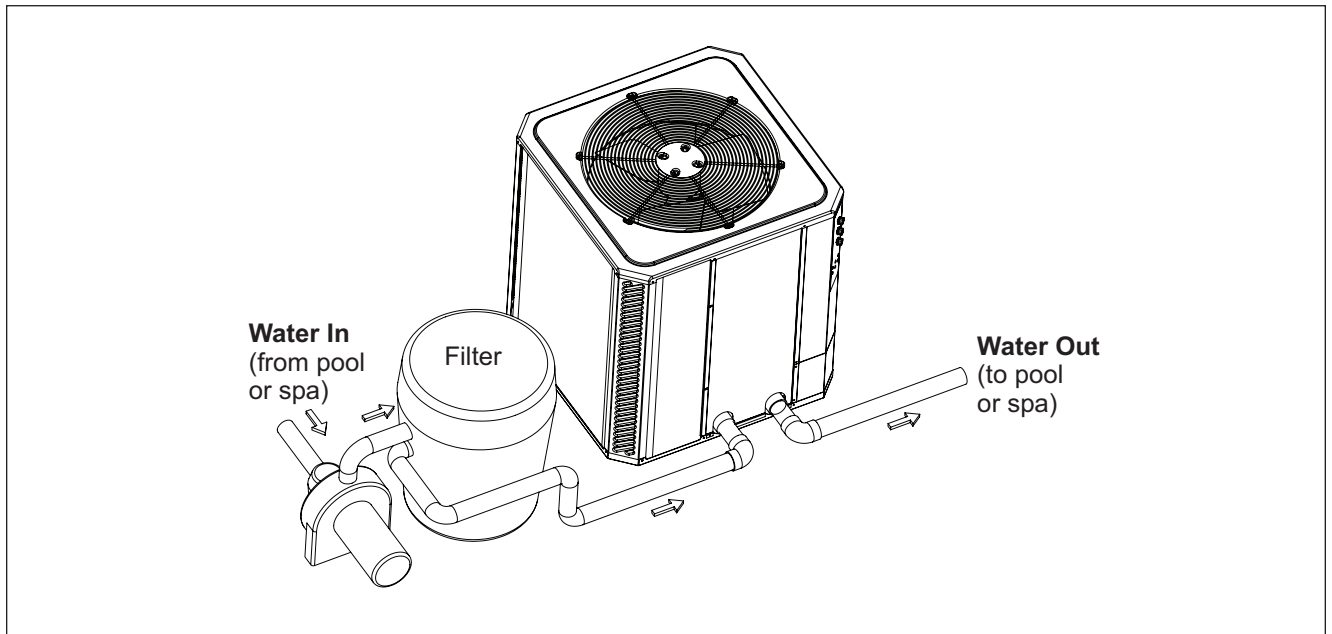

**Fig. 6:** For systems with pumps of less than 2 HP (under 80 gpm), no external bypass is required. Connections are 2-inch unions. Plumb the heat pump pool heater AFTER the filter and BEFORE any chlorinators.

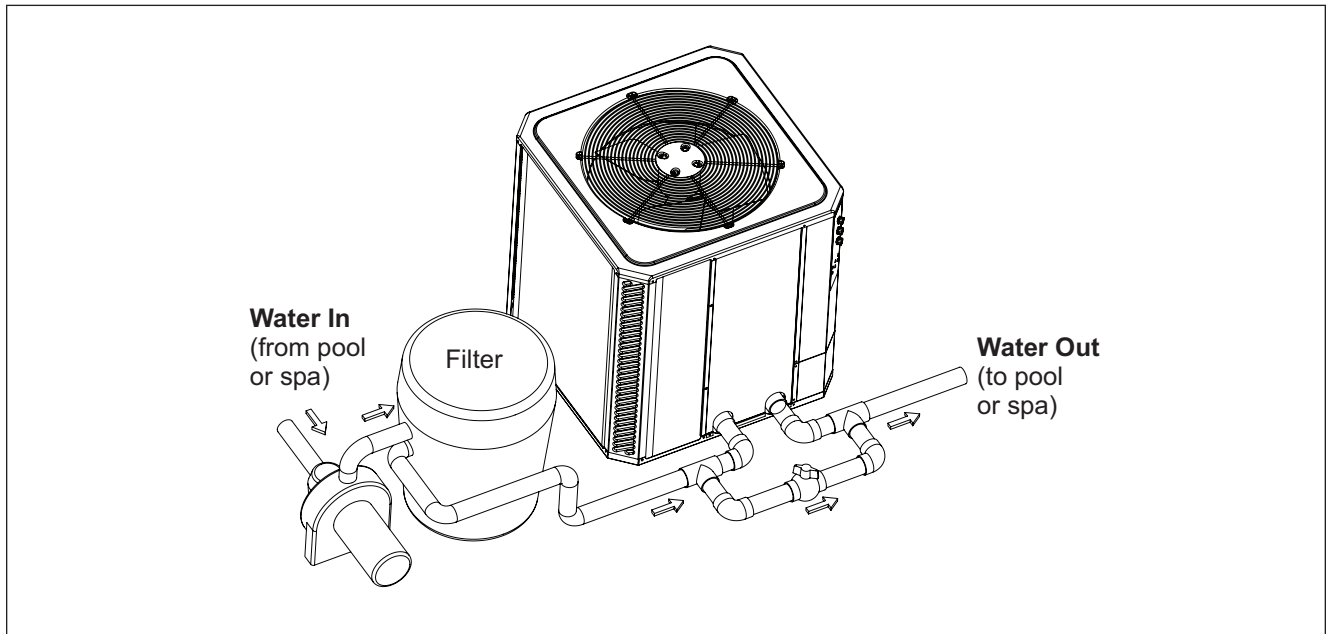

**Fig. 7:** For systems with pumps of 2 HP or greater (over 80 gpm), an external bypass is required. Adjust the bypass valve to divert a minimum of 40 gpm through the heat pump pool heater. Connections are 2-inch unions. Plumb the heat pump pool heater AFTER the filter and BEFORE any chlorinators.

	MINIMUM PIPE SIZES	
	BRANCH	MAIN
130	1-1/2"	2"
206-407	1-1/2"	2"

THIS PIPING DIAGRAM IS RAYPAK'S RECOMMENDATION AND IS NOT INTENDED TO REPLACE AN ENGINEERED PIPING SYSTEM DESIGNED BY A PROFESSIONAL ENGINEER.

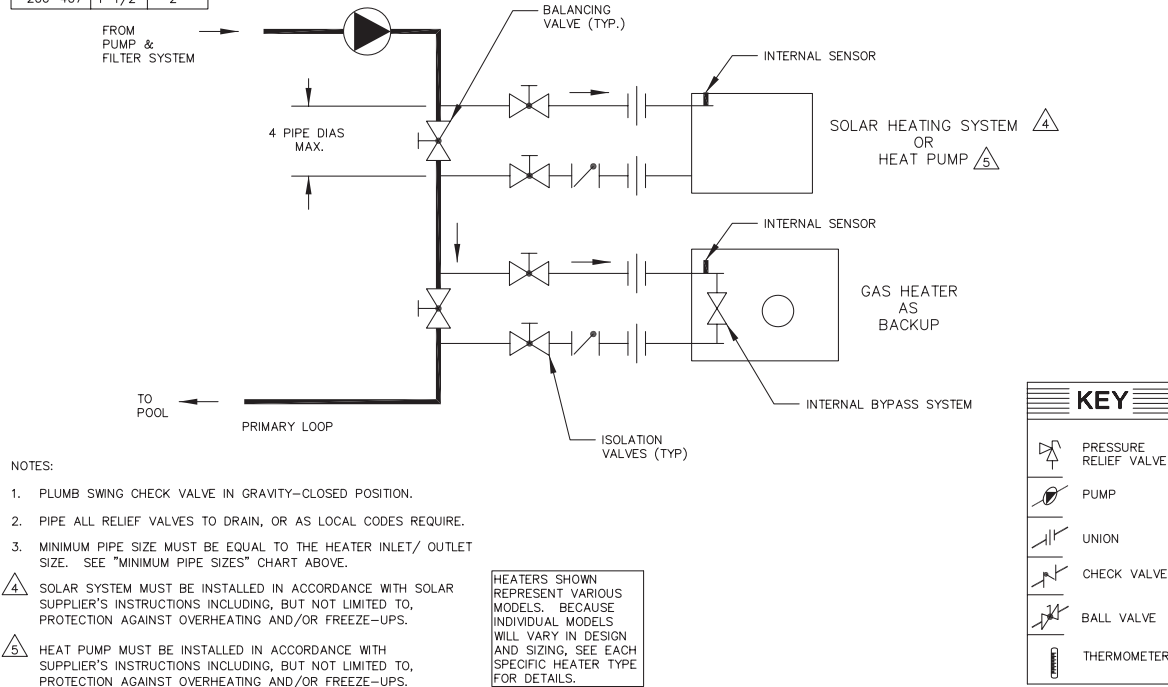

**Fig. 8: Pool Piping for Heat Pump Pool Heater and Gas Pool Heater**

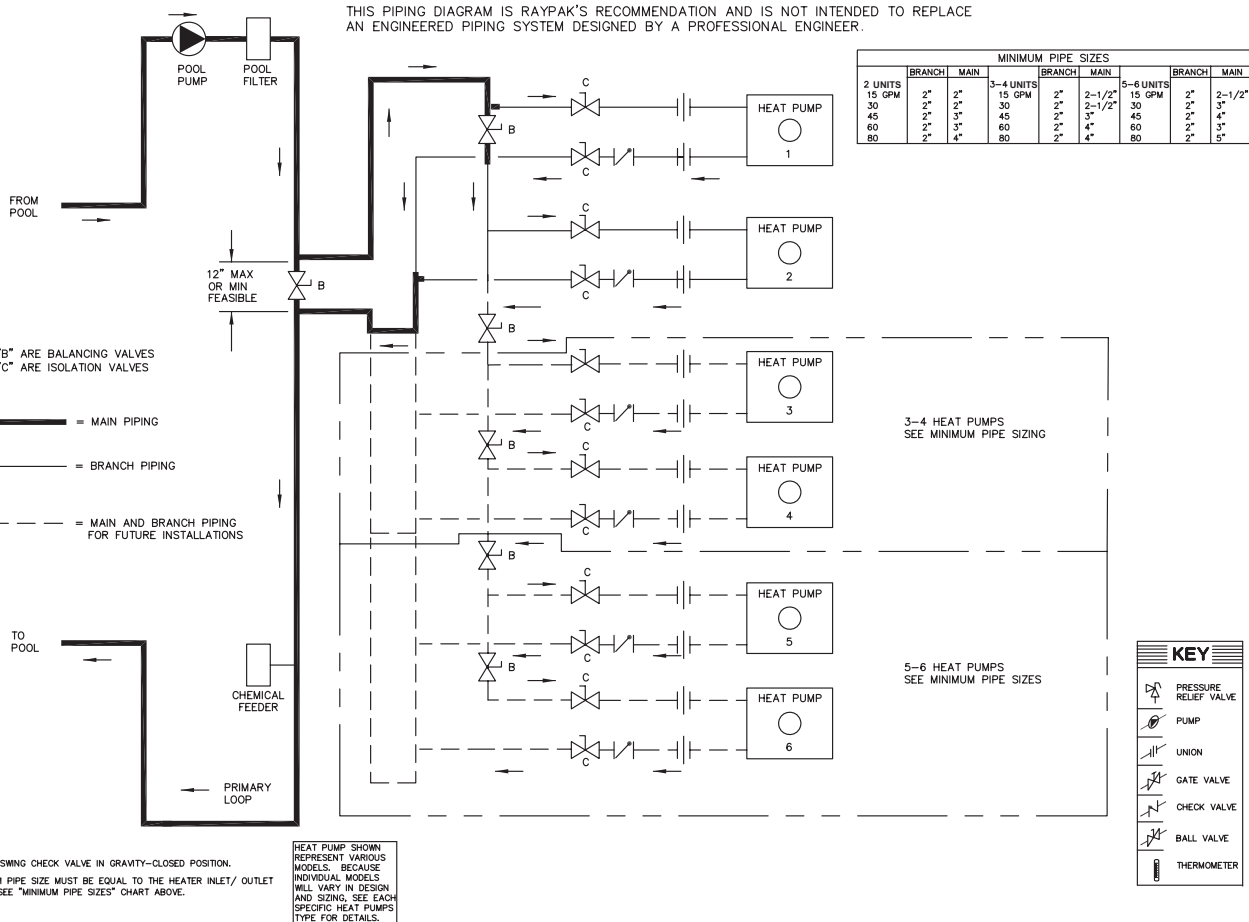

**Fig. 9: Pool Piping for Heat Pump Pool Heaters, Multiple, Primary/Secondary**

# Wiring Diagram — 208V/230V Single-Phase — Analog Models

USE COPPER CONDUCTORS ONLY  
USE 75 ° C 600 V WIRE  
TORQUE SCREWS : 40 LB - IN

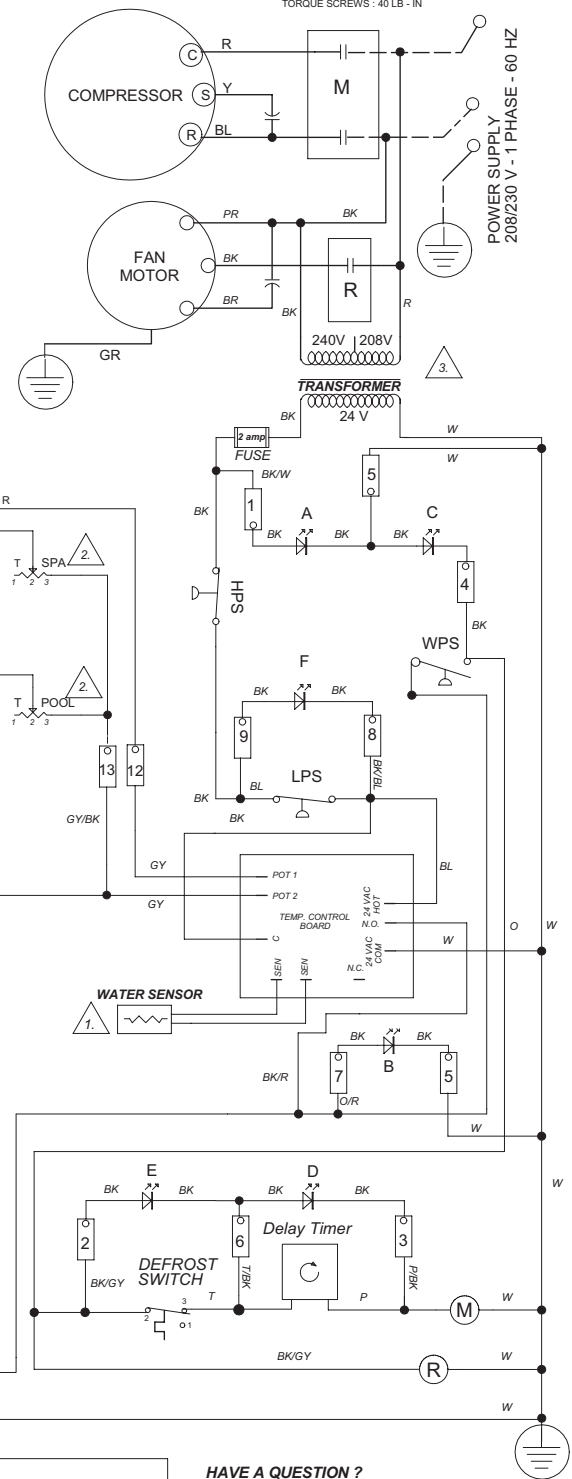
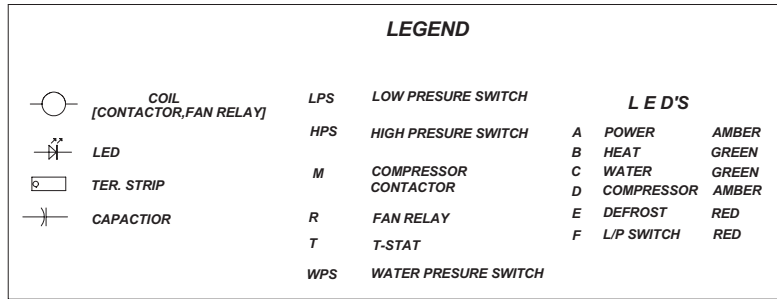

### SPA / REMOTE / POOL SWITCH SHOWN IN POOL POSITION

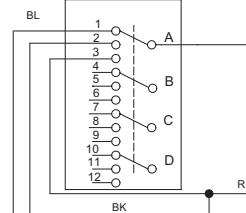

**NOTES:**

1. SENSOR RATED @  
75° 10.5K  
77° 10K  
84° 8.50K

2. T-STAT RATED @  
75° 4.73K  
77° 4.25  
84° 2.44K

3. TRANSFORMER WIRED FOR 240V, MOVE RED WIRE TO 208 TER. FOR 208V

**WIRE COLOR CODE**

BK	BLACK	P	PINK
BL	BLUE	PR	PURPLE
BR	BROWN	R	RED
G	GREEN	T	TAN
GY	GRAY	W	WHITE
O	ORANGE	Y	YELLOW

**WIRING INFORMATION**

USE COPPER CONDUCTORS ONLY  
USE 75 ° C 600 V WIRE

LINE VOLTAGE  
FACTORY STANDARD \_\_\_\_\_  
FIELD INSTALLED \_\_\_\_\_

LOW VOLTAGE  
FACTORY STANDARD \_\_\_\_\_  
FACTORY OPTION \_\_\_\_\_

USE TERMINALS 21 & 22 TO ATTACH 2 WIRE CONTROL SYSTEMS THAT HAVE THEIR OWN SENSORS FOR TEMPERATURE CONTROL.

USE TERMINALS 22, 23 & 24 TO ATTACH 3 WIRE CONTROL SYSTEM THAT UTILIZE OUR TEMPERATURE SENSOR FOR TEMPERATURE CONTROL.

TO ENGAGE AN EXTERNAL CONTROL SYSTEM PUT THE POOL-REMOTE-SPA SWITCH IN THE REMOTE POSITION

**HAVE A QUESTION ?  
CALL 800-375-7378**

POOL HEAT PUMP 5310, 6310, 8320	
REV 082708	DWG NUMBER <b>00-11029</b>

# Wiring Diagram

## 208V/230V

### Single-Phase

### Digital Models

USE COPPER CONDUCTORS ONLY  
USE 75 ° C 600 V WIRE  
TORQUE SCREWS : 40 LB - IN

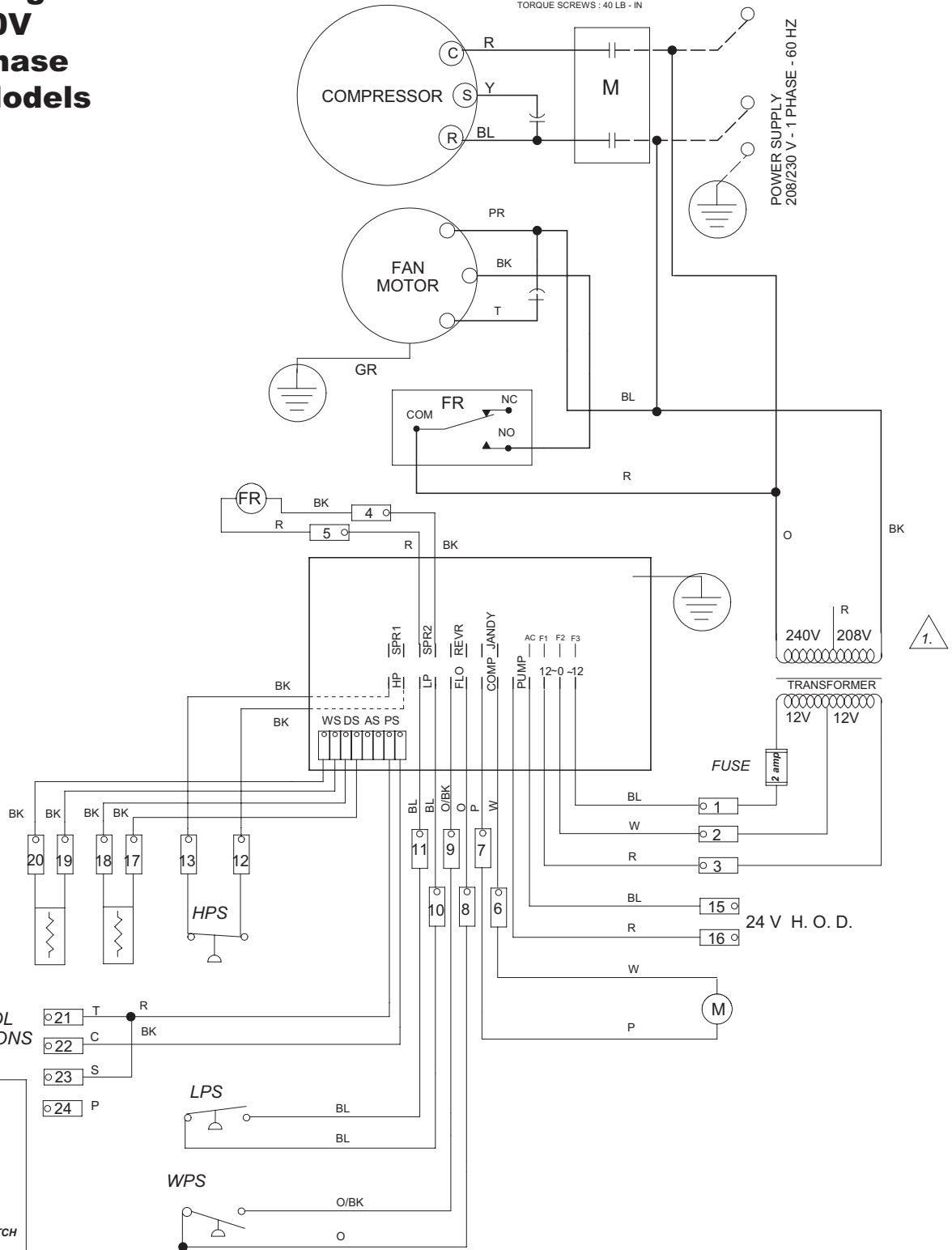

#### REMOTE CONTROL FIELD CONNECTIONS

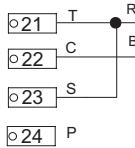

LEGEND	
	COIL [CONACTOR, FAN & POWER DEFROST]
	TER. STRIP
	CAPACITOR
	FAN RELAY
	LOW PRESURE SWITCH
	HIGH PRESURE SWITCH
	COMPRESSOR CONTACTOR
	WATER PRESURE SWITCH

**NOTES:**

1. TRANSFORMER WIRED FOR 240V, BLACK & ORANGE WIRE FOR 240V, BLACK & RED WIRE FOR 208V

WIRE COLOR CODE			
BK	BLACK	P	PINK
BL	BLUE	PR	PURPLE
BR	BROWN	R	RED
G	GREEN	T	TAN
GY	GRAY	W	WHITE
O	ORANGE	Y	YELLOW

WIRING INFORMATION	
LINE VOLTAGE	
FACTORY STANDARD	————
FIELD INSTALLED	- - - - -
LOW VOLTAGE	
FACTORY STANDARD	————
FACTORY OPTION	- - - - -
2 WIRE REMOTE CONTROL	
USE TERMINALS 21 & 22 TO ATTACH 2 WIRE CONTROL SYSTEMS THAT HAVE THEIR OWN SENSORS FOR TEMPERATURE CONTROL.	
SET POOL TEMPERATURE TO OFF AND SET SPA TEMPERATURE TO 104	

<b>HAVE A QUESTION ?</b> CALL 800-375-7378	
POOL HEAT PUMP, SCROLL COMPRESSOR DIGITAL CONTROL	
REV 072606	DWG NUMBER 01-0669

# Wiring Diagram — 208V/230V 3-Phase — Analog Models

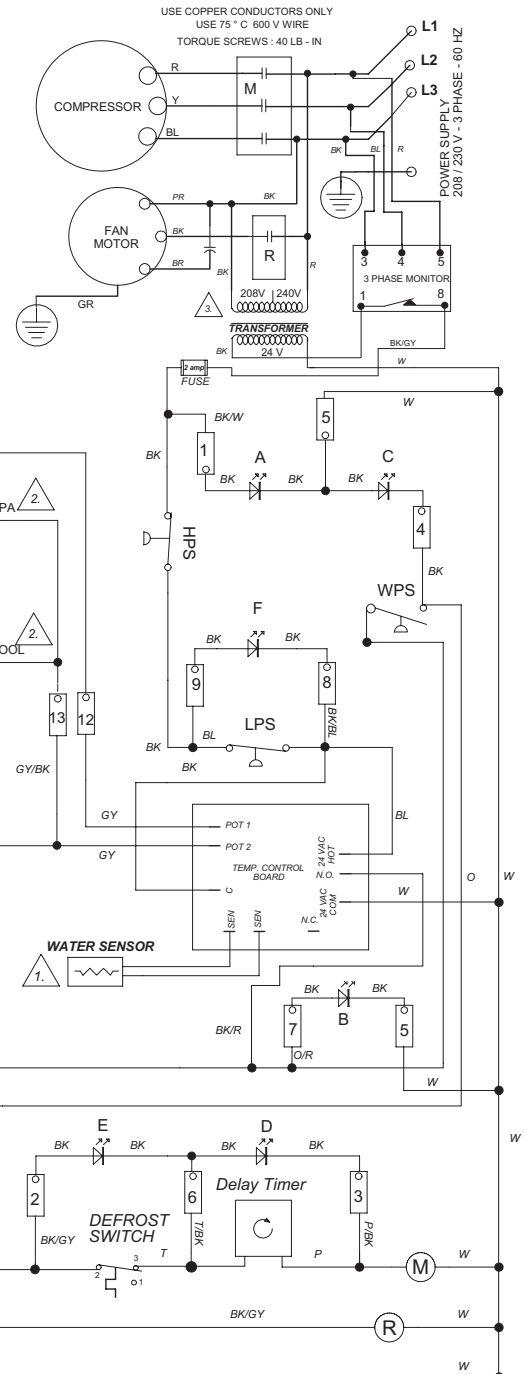
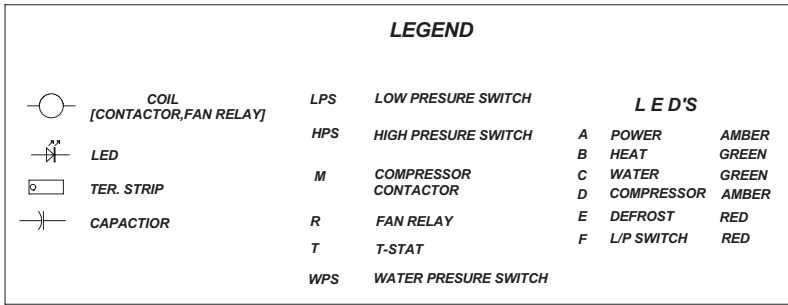

ATTACH TO TERMINALS T & C ON SLAVE UNITS  
POOL-REMOTE-SPA SWITCH TO REMOTE

REMOTE CONTROL  
FIELD CONNECTIONS

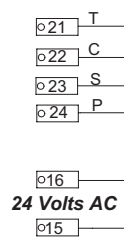

**NOTES:**

1. SENSOR RATED @  
75° 10.5K  
77° 10K  
84° 8.50K

2. T-STAT RATED @  
75° 4.73K  
77° 4.25  
84° 2.44K

3. TRANSFORMER WIRED FOR 240V,  
MOVE RED WIRE TO 208 TER. FOR  
208V

**WIRE COLOR CODE**

BK	BLACK	P	PINK
BL	BLUE	PR	PURPLE
BR	BROWN	R	RED
G	GREEN	T	TAN
GY	GRAY	W	WHITE
O	ORANGE	Y	YELLOW

**WIRING INFORMATION**

USE COPPER CONDUCTORS ONLY  
USE 75 ° C 600 V WIRE

LINE VOLTAGE  
FACTORY STANDARD ———  
FIELD INSTALLED ———

LOW VOLTAGE  
FACTORY STANDARD ———  
FACTORY OPTION - - - - -

USE TERMINALS 21 & 22 TO ATTACH 2 WIRE CONTROL SYSTEMS THAT HAVE THEIR OWN SENSORS FOR TEMPERATURE CONTROL.

USE TERMINALS 22, 23 & 24 TO ATTACH 3 WIRE CONTROL SYSTEM THAT UTILIZE OUR TEMPERATURE SENSOR FOR TEMPERATURE CONTROL.

TO ENGAGE AN EXTERNAL CONTROL SYSTEM PUT THE POOL-REMOTE-SPA SWITCH IN THE REMOTE POSITION

**HAVE A QUESTION ?  
CALL 800-375-7378**

POOL HEAT PUMP 3 PHASE 208 / 230 V 60hz	
REV 120808	DWG NUMBER <b>00-11047</b>

# Wiring Diagram — 208V/230V 3-Phase — Digital Models

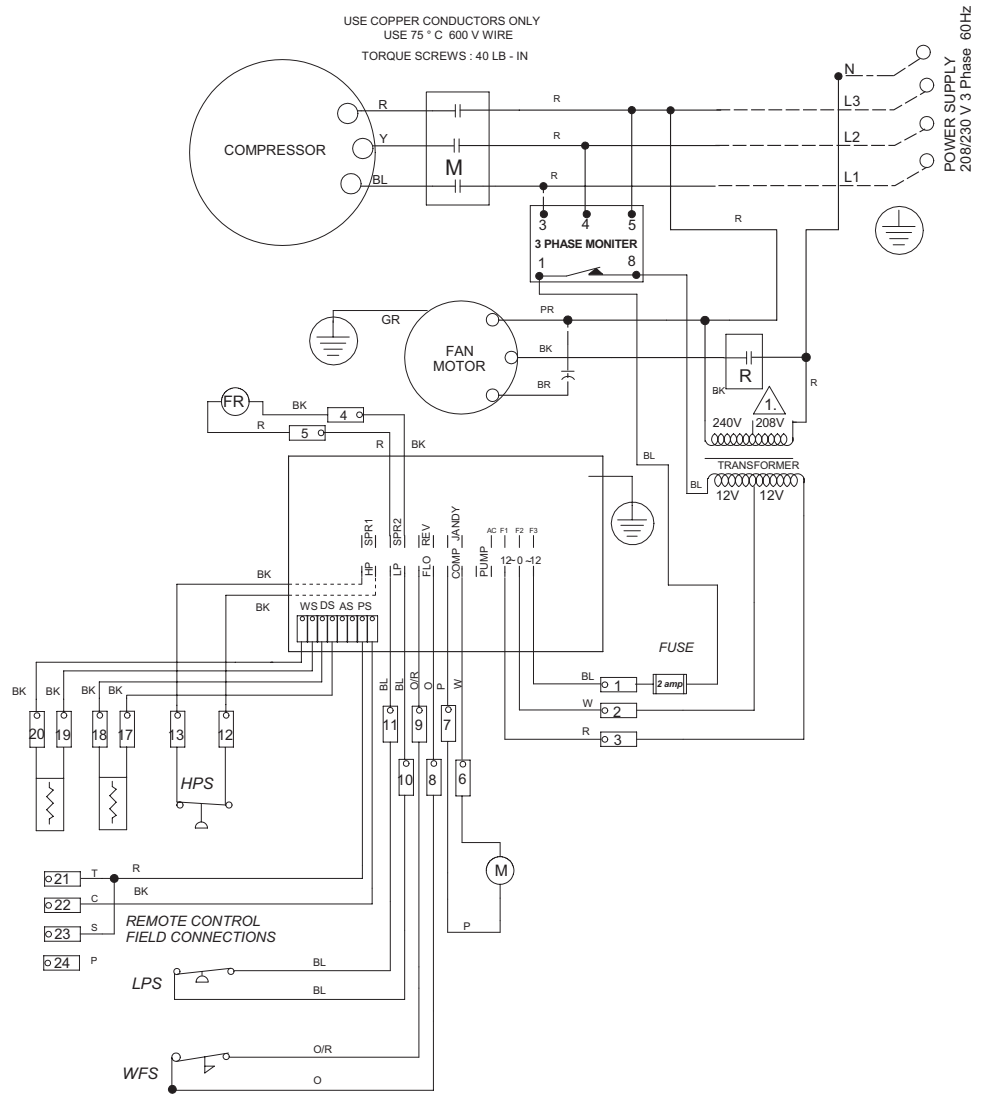

**LEGEND**

- COIL (CONTACTOR)
- TER. STRIP
- CAPACITOR
- SENSOR

FR FAN RELAY  
LPS LOW PRESURE SWITCH  
HPS HIGH PRESURE SWITCH  
M COMPRESSOR CONTACTOR  
RS REVERSING SOLENOID  
WFS WATER FLOW SWITCH

**WIRE COLOR CODE**

BK	BLACK	P	PINK
BL	BLUE	PR	PURPLE
BR	BROWN	R	RED
G	GREEN	T	TAN
GY	GRAY	W	WHITE
O	ORANGE	Y	YELLOW

**WIRING INFORMATION**

**LINE VOLTAGE**  
 FACTORY STANDARD \_\_\_\_\_  
 FIELD INSTALLED - - - - -  
**LOW VOLTAGE**  
 FACTORY STANDARD \_\_\_\_\_  
 FACTORY OPTION - - - - -

**2 WIRE REMOTE CONTROL**  
 USE TERMINALS 21 & 22 TO ATTACH 2 WIRE CONTROL SYSTEMS THAT HAVE THEIR OWN SENSORS FOR TEMPERATURE CONTROL.  
 SET POOL TEMPERATURE TO OFF AND SET SPA TEMPERATURE TO 104

**NOTES:**

1. TRANSFORMER WIRED FOR 240V, BLACK & ORANGE WIRE FOR 240V, BLACK & RED WIRE FOR 208V

POOL HEAT PUMP, SCROLL COMPRESSOR DIGITAL CONTROL, 208/230V 3 Phase 60Hz	
REV 040809	DWG NUMBER 0011099

# Wiring Diagram

## 208V/230V

### Single-Phase

### Model 6330HC

POWER SUPPLY  
200/220 V - 1 PHASE - 50Hz  
208/230 V - 1 PHASE - 60 HZ

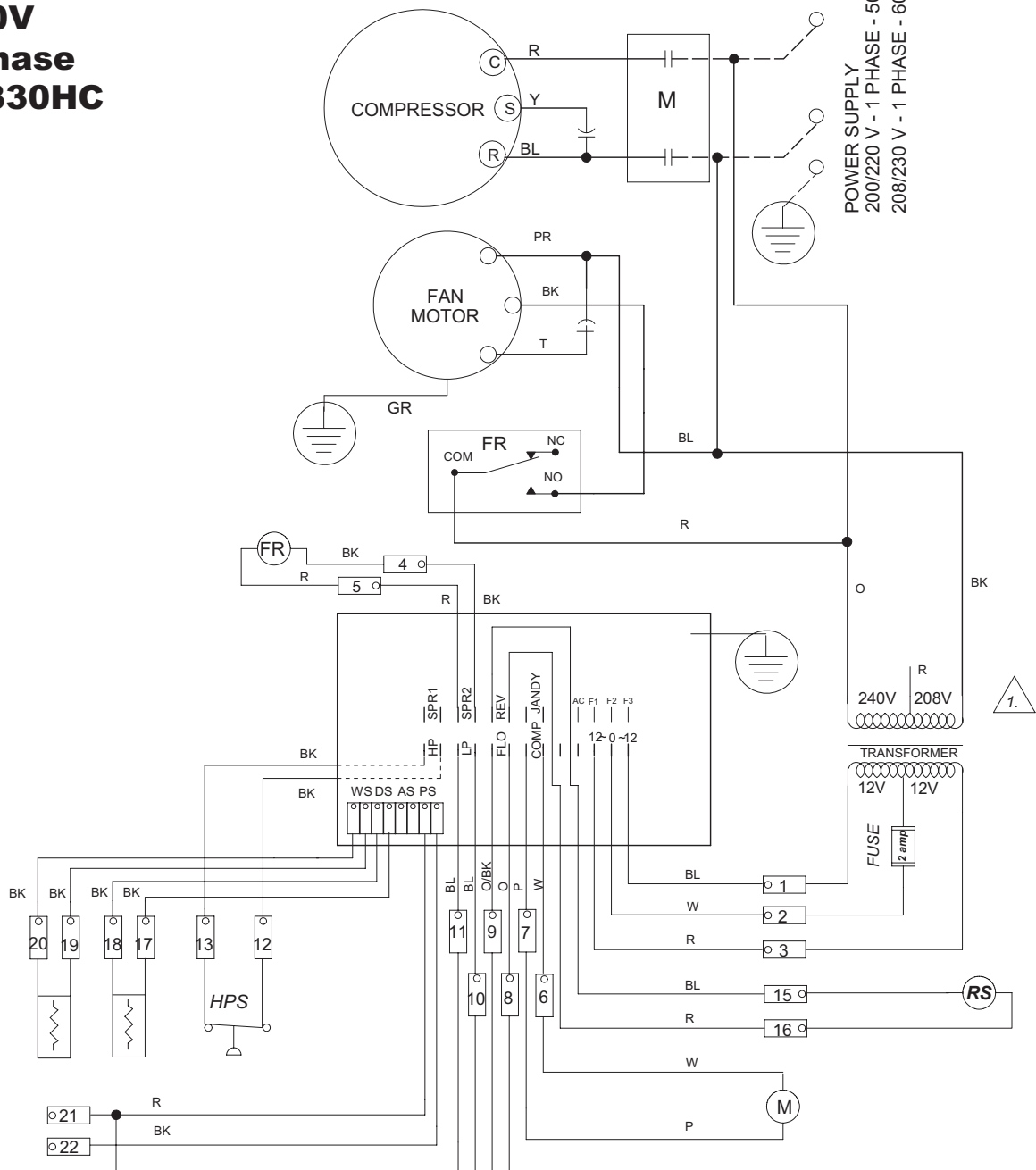

- LEGEND**
- COIL [CONACTOR, FAN & POWER DEFROST]
  - TER. STRIP
  - CAPACITOR
  - FR** FAN RELAY
  - LPS** LOW PRESURE SWITCH
  - HPS** HIGH PRESURE SWITCH
  - M** COMPRESSOR CONTACTOR
  - RS** REVERSING SOLENOID
  - WPS** WATER PRESURE SWITCH

**NOTES:**

TRANSFORMER WIRED FOR 240V, BLACK & ORANGE WIRE FOR 240V, BLACK & RED W WIRE FOR 208V

**WIRE COLOR CODE**

BK	BLACK	P	PINK
BL	BLUE	PR	PURPLE
BR	BROWN	R	RED
G	GREEN	T	TAN
GY	GRAY	W	WHITE
O	ORANGE	Y	YELLOW

**WIRING INFORMATION**

LINE VOLTAGE  
FACTORY STANDARD ———  
FIELD INSTALLED - - - - -

LOW VOLTAGE  
FACTORY STANDARD ———  
FACTORY OPTION - - - - -

USE TERMINALS 21 & 22 TO ATTACH 2 WIRE CONTROL SYSTEMS THAT HAVE THEIR OWN SENSORS FOR TEMPERATURE CONTROL. SET THE POOL TO OFF - SET THE SPA TO 104

**HAVE A QUESTION ?**  
CALL 800-375-7378

POOL HEAT PUMP, SCROLL COMPRESSOR DIGITAL CONTROL, H/C	
REV 112806	DWG NUMBER 00- 10812

# Wiring Diagram — 208V/230V 3-Phase — Model 6333HC

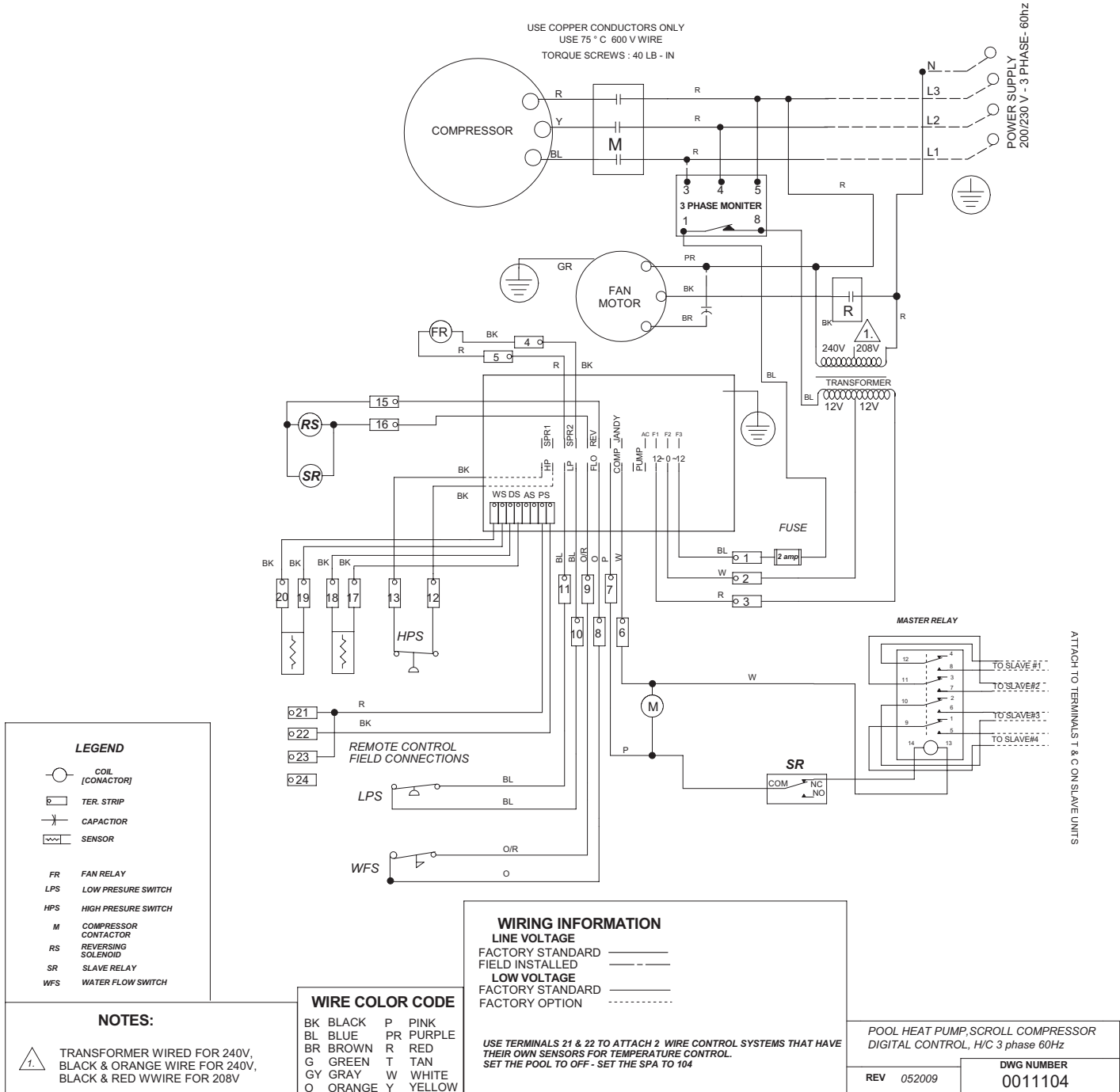



## Installing a Remote Control Device on Analog Heaters

### Wiring

For a 2-wire control, use the **TOTAL** and **COMMON** connections on the heat pump pool heater wiring block.

For a 3-wire control, use the **COMMON**, **SPA** and **POOL** connections on the heat pump pool heater wiring block.

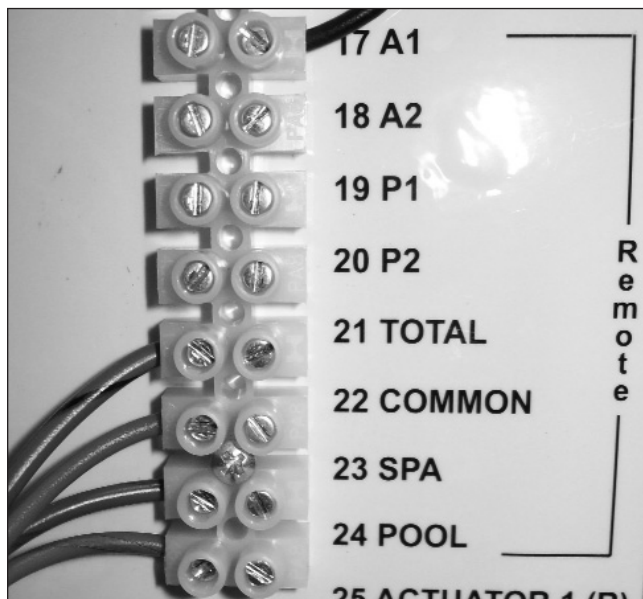

Fig. 10: Heater Wiring Block — Analog Heaters

### Heater Settings

1. To operate the heater using a **2-wire** remote control device, simply switch the **Spa-Remote-Pool** knob to the **Remote** position and make sure the heater is enabled on the remote control device.
2. To operate the heater using a **3-wire** remote control device, simply switch the **Spa-Remote-Pool** knob to the **Remote** position and set the temperature for pool and spa.

## Installing a Remote Control Device on Digital Heaters

### Wiring

For a 2-wire control, use the **TOTAL** and **COMMON** connections on the heat pump pool heater wiring block.

For a 3-wire control, use the **COMMON**, **SPA** and **POOL** connections on the heat pump pool heater wiring block.

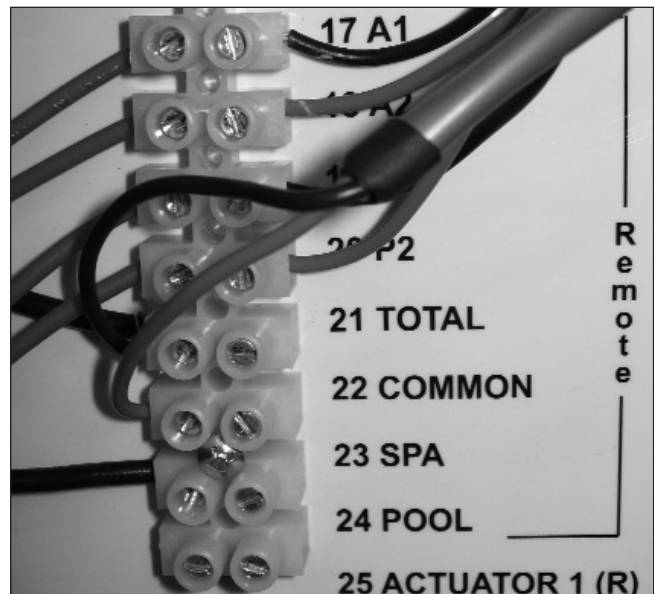

Fig. 11: Heater Wiring Block — Digital Heaters

### Heater Settings

1. Make sure the heater is disabled on the remote control device. Then, push the SET key until **POL** is displayed. Push the DOWN arrow key until OFF is displayed. Wait until a temperature is displayed before beginning the next step.
2. Push the SET key until **SPA** is displayed, then push the UP arrow to **104°F**. Wait until a temperature is displayed before beginning the next step.
3. Push the SET key until **P\_S** is displayed, then push the DOWN arrow until **POL** is displayed. Wait until a temperature is displayed before beginning the next step.
4. Finally, enable the heater on the remote control device. When there is a call for heat, the heater display will show **SPA**. When the heater is disabled, the display will show **POL**.





